



EFR32xG24 Wireless SoC Reference Manual



The EFR32xG24 Wireless SoC includes the EFR32BG24 and EFR32MG24 Wireless families. The EFR32xG24 improves processing capability with an ARM Cortex®-M33 core, while providing for lower active current for both the MCU and radio. This low power and application-optimized device supports Bluetooth 5.3 (including Direction Finding), Proprietary 2.4 GHz & Zigbee PRO/Green Power protocols.

The EFR32xG24 solution provides industry-leading energy efficiency, processing capability, and RF performance in a small form factor for IoT connected applications.

KEY FEATURES

- 32-bit ARM Cortex®-M33 core with up to 78.0 MHz maximum operating frequency
- Scalable Memory and Radio configuration options available in QFN packaging
- Integrated PA with up to 19.5 dBm transmit power
- Energy-efficient radio core with low active and sleep currents
- Secure Vault™
- AI/ML Hardware Accelerator

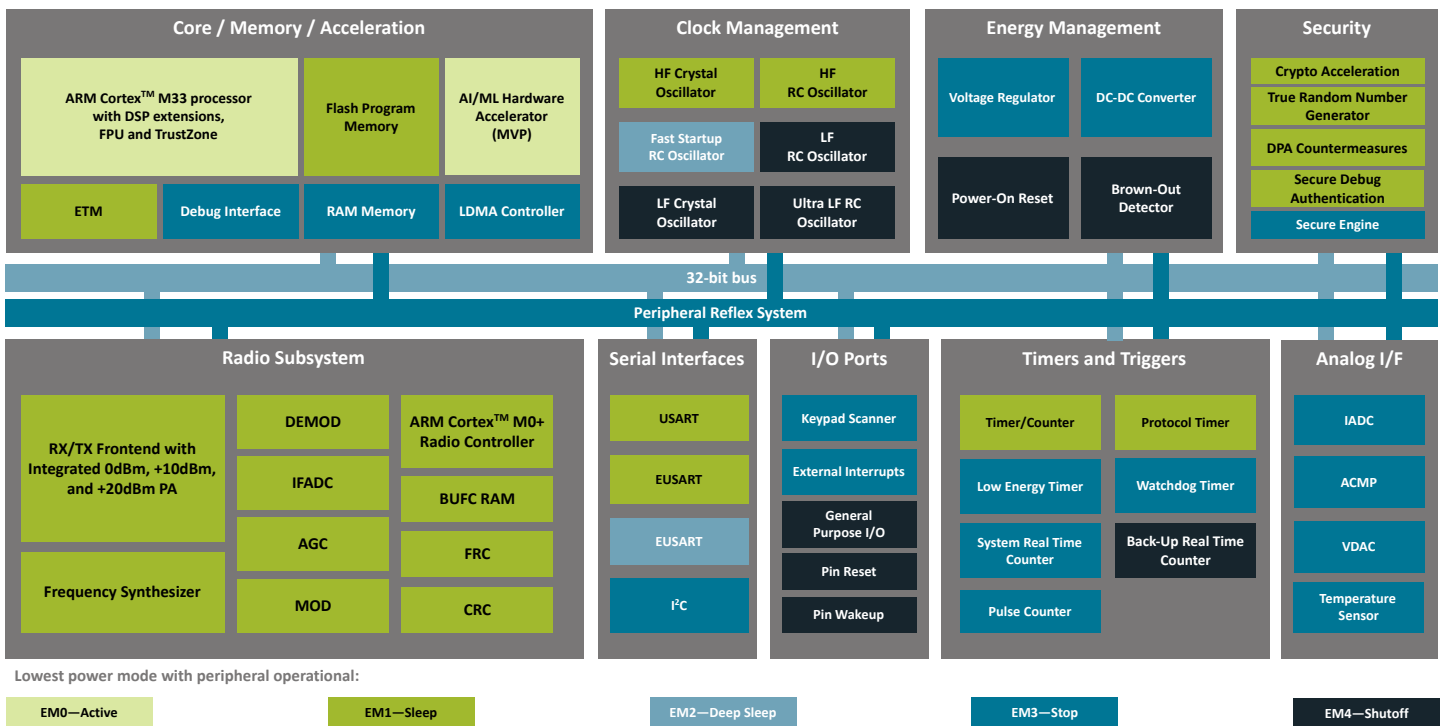

Table of Contents

1. About This Document	27
1.1 Introduction	27
1.2 Conventions	28
1.3 Related Documentation	29
2. System Overview	30
2.1 Introduction	31
2.2 Block Diagrams	32
2.3 MCU Features overview	33
3. System Processor	35
3.1 Introduction	35
3.2 Features	36
3.3 Functional Description	36
3.3.1 Interrupt Operation	37
3.3.2 TrustZone	37
3.3.3 Interrupt Request Lines (IRQ)	38
4. Memory and Bus System	41
4.1 Introduction	41
4.2 Functional Description	42
4.2.1 Bus Matrix	43
4.2.2 Flash	44
4.2.3 SRAM	44
4.2.4 Peripherals	44
5. Radio Transceiver	50
5.1 Introduction	51
5.1.1 RF Frequency Synthesizer	51
5.1.2 Modulation Modes	52
5.1.3 Transmit Mode	52
5.1.4 Receive Mode	52
5.1.5 Data Buffering	52
5.1.6 Unbuffered Data Transfer	52
5.1.7 Frame Format Support	53
5.1.8 Hardware CRC Support	53
5.1.9 Convolutional Encoding / Decoding	53
5.1.10 Binary Block Encoding / Decoding	53
5.1.11 Data Encryption and Authentication	54
5.1.12 RF Test Modes	54
6. MSC - Memory System Controller	55
6.1 Introduction	55
6.2 Features	56

6.3	Functional Description	.56
6.3.1	RAM Configuration	.56
6.3.2	Instruction Cache	.57
6.3.3	Device Information (DI) Page	.57
6.3.4	User Data (UD) Page Description	.57
6.3.5	Bootloader	.57
6.3.6	Post-reset Behavior	.57
6.3.7	Flash Startup	.57
6.3.8	Flash EM0 / EM1 Power Down	.57
6.3.9	Wait-states	.57
6.3.10	Cortex®-M33 If-Then Block Folding	.58
6.3.11	Line Buffering (Prefetch)	.58
6.3.12	Erase and Write Operations	.59
6.4	DEVINFO - Device Info Page	.60
6.4.1	DEVINFO Register Map	.61
6.4.2	DEVINFO Register Description	.62
6.5	ICACHE - Instruction Cache	.90
6.5.1	Cache Operation	.90
6.5.2	Performance Measurement	.91
6.5.3	ICACHE Register Map	.92
6.5.4	ICACHE Register Description	.93
6.6	SYSCFG - System Configuration	.99
6.6.1	RAM Retention	.99
6.6.2	ECC	.100
6.6.3	Software Interrupts	.100
6.6.4	Bus faults	.100
6.6.5	SYSCFG Register Map	.101
6.6.6	SYSCFG Register Description	.104
6.6.7	MPAHBRAM Register Map	.121
6.6.8	MPAHBRAM Register Description	.122
6.7	MSC Register Map	.129
6.8	MSC Register Description	.131
6.8.1	MSC_IPVERSION - IP Version ID	.131
6.8.2	MSC_READCTRL - Read Control Register	.132
6.8.3	MSC_RDATACTRL - Read Data Control Register	.133
6.8.4	MSC_WRITECTRL - Write Control Register	.134
6.8.5	MSC_WRITECMD - Write Command Register	.135
6.8.6	MSC_ADDRB - Page Erase/Write Address Buffer	.136
6.8.7	MSC_WDATA - Write Data Register	.136
6.8.8	MSC_STATUS - Status Register	.137
6.8.9	MSC_IF - Interrupt Flag Register	.138
6.8.10	MSC_IEN - Interrupt Enable Register	.139
6.8.11	MSC_USERDATASIZE - User Data Region Size Register	.140
6.8.12	MSC_CMD - Command Register	.140
6.8.13	MSC_LOCK - Configuration Lock Register	.141
6.8.14	MSC_MISLOCKWORD - Mass Erase and User Data Page Lock Word	.141
6.8.15	MSC_PWRCTRL - Power Control Register	.142

6.8.16	MSC_PAGELOCK0 - Main Space Page 0-31 Lock Word	143
6.8.17	MSC_PAGELOCK1 - Main Space Page 32-63 Lock Word	143
6.8.18	MSC_PAGELOCK2 - Main Space Page 64-95 Lock Word	144
6.8.19	MSC_PAGELOCK3 - Main Space Page 96-127 Lock Word	144
6.8.20	MSC_PAGELOCK4 - Main Space Page 128-159 Lock Word	145
6.8.21	MSC_PAGELOCK5 - Main Space Page 160-191 Lock Word	145
7.	DBG - Debug Interface	146
7.1	Introduction	146
7.2	Features	146
7.3	Functional Description	147
7.3.1	Debug Pins	147
7.3.2	Embedded Trace Macrocell (ETM)	147
7.3.3	Debug and EM2/EM3	147
8.	CMU - Clock Management Unit	148
8.1	Introduction	148
8.2	Features	148
8.3	Functional Description	149
8.3.1	System Clocks	152
8.3.2	Switching Clock Source	156
8.3.3	RC Oscillator Calibration	158
8.3.4	Energy Modes	161
8.3.5	Clock Output	162
8.3.6	Clock Input from a Pin	162
8.3.7	Interrupts	162
8.3.8	Protection	162
8.4	CMU Register Map	163
8.5	CMU Register Description	166
8.5.1	CMU_IPVERSION - IP Version ID	166
8.5.2	CMU_STATUS - Status Register	167
8.5.3	CMU_LOCK - Configuration Lock Register	168
8.5.4	CMU_WDOGLOCK - WDOG Configuration Lock Register	168
8.5.5	CMU_IF - Interrupt Flag Register	169
8.5.6	CMU_IEN - Interrupt Enable Register	169
8.5.7	CMU_CALCMD - Calibration Command Register	170
8.5.8	CMU_CALCTRL - Calibration Control Register	171
8.5.9	CMU_CALCNT - Calibration Result Counter Register	172
8.5.10	CMU_CLKEN0 - Clock Enable Register 0	173
8.5.11	CMU_CLKEN1 - Clock Enable Register 1	175
8.5.12	CMU_SYCLKCTRL - System Clock Control	177
8.5.13	CMU_TRACECLKCTRL - Debug Trace Clock Control	178
8.5.14	CMU_EXPORTCLKCTRL - Export Clock Control	179
8.5.15	CMU_DPLLREFCLKCTRL - Digital PLL Reference Clock Control	181
8.5.16	CMU_EM01GRPACLKCTRL - EM01 Peripheral Group a Clock Control	182
8.5.17	CMU_EM01GRPCCLKCTRL - EM01 Peripheral Group C Clock Control	183
8.5.18	CMU_EM23GRPACLKCTRL - EM23 Peripheral Group a Clock Control	184

8.5.19	CMU_EM4GRPACLKCTRL - EM4 Peripheral Group a Clock Control	184
8.5.20	CMU_IADCCLKCTRL - IADC Clock Control	185
8.5.21	CMU_WDOG0CLKCTRL - Watchdog0 Clock Control	185
8.5.22	CMU_WDOG1CLKCTRL - Watchdog1 Clock Control	186
8.5.23	CMU_EUSART0CLKCTRL - EUSART0 Clock Control	187
8.5.24	CMU_SYSRTC0CLKCTRL - System RTC0 Clock Control	188
8.5.25	CMU_VDAC0CLKCTRL - VDACC0 Clock Control	189
8.5.26	CMU_PCNT0CLKCTRL - Pulse Counter 0 Clock Control	190
8.5.27	CMU_RADIOCLKCTRL - Radio Clock Control	190
8.5.28	CMU_VDAC1CLKCTRL - VDACC1 Clock Control	191
9.	Oscillators	192
9.1	Introduction	192
9.2	HFXO - High Frequency Crystal Oscillator	192
9.2.1	Introduction	192
9.2.2	Features	192
9.2.3	Functional Description	193
9.2.4	HFXO Register Map	197
9.2.5	HFXO Register Description	198
9.3	HFRCO - High-Frequency RC Oscillator	217
9.3.1	Introduction	217
9.3.2	Features	217
9.3.3	Functional Description	217
9.3.4	HFRCO Register Map	220
9.3.5	HFRCO Register Description	221
9.4	DPLL - Digital Phased Locked Loop	225
9.4.1	Introduction	225
9.4.2	Features	225
9.4.3	Functional Description	225
9.4.4	DPLL Register Map	227
9.4.5	DPLL Register Description	228
9.5	LFXO - Low-Frequency Crystal Oscillator	233
9.5.1	Introduction	233
9.5.2	Features	233
9.5.3	Functional Description	233
9.5.4	LFXO Register Map	235
9.5.5	LFXO Register Description	236
9.6	LFRCO - Low-Frequency RC Oscillator	243
9.6.1	Introduction	243
9.6.2	Features	243
9.6.3	Functional Description	243
9.6.4	LFRCO Register Map	246
9.6.5	LFRCO Register Description	247
9.7	FSRCO - Fast Start RCO	254
9.7.1	Introduction	254
9.7.2	Features	254
9.7.3	Functional Description	254

9.7.4	FSRCO Register Map	254
9.7.5	FSRCO Register Description	255
9.8	ULFRCO - Ultra Low Frequency RC Oscillator	255
9.8.1	Introduction	255
9.8.2	Features	255
9.8.3	Functional Description	255
10.	SMU - Security Management Unit	256
10.1	Introduction	256
10.2	Features	256
10.3	Functional Description	257
10.3.1	Bus Level Security	257
10.3.2	Privileged Access Control	258
10.3.3	Secure Access Control	258
10.3.4	ARM TrustZone	259
10.3.5	Configuring Managers	259
10.3.6	Configuring Peripherals	259
10.3.7	Configuring Memory	260
10.3.8	Cortex®-M33 Integration	260
10.3.9	Exception Handling	261
10.3.10	SMU Lock	261
10.4	SMU Register Map	262
10.5	SMU Register Description	264
10.5.1	SMU_IPVERSION - IP Version	264
10.5.2	SMU_STATUS - Status Register	265
10.5.3	SMU_LOCK - Lock Register	265
10.5.4	SMU_IF - Interrupt Flag Register	266
10.5.5	SMU_IEN - Interrupt Enable Register	267
10.5.6	SMU_M33CTRL - M33 Control Settings	268
10.5.7	SMU_PPUPATD0 - Privileged Access	269
10.5.8	SMU_PPUPATD1 - Privileged Access	271
10.5.9	SMU_PPUSATD0 - Secure Access	273
10.5.10	SMU_PPUSATD1 - Secure Access	275
10.5.11	SMU_PPUFS - Fault Status	276
10.5.12	SMU_BMPUPATD0 - Privileged Attribute	277
10.5.13	SMU_BMPUSATD0 - Secure Attribute	278
10.5.14	SMU_BMPUFS - Fault Status	279
10.5.15	SMU_BMPUFSADDR - Fault Status Address	279
10.5.16	SMU_ESAURTYPES0 - Region Types 0	280
10.5.17	SMU_ESAURTYPES1 - Region Types 1	280
10.5.18	SMU_ESAUMRB01 - Movable Region Boundary	281
10.5.19	SMU_ESAUMRB12 - Movable Region Boundary	281
10.5.20	SMU_ESAUMRB45 - Movable Region Boundary	282
10.5.21	SMU_ESAUMRB56 - Movable Region Boundary	282
11.	SE - Secure Engine Subsystem	283
11.1	Introduction	283

11.2	Security Features	283
11.2.1	Security Features Overview	283
11.2.2	Secure Boot with Root of Trust and Secure Loader (RTSL)	284
11.2.3	Secure Debug	284
11.2.4	Cryptographic Accelerator	284
11.2.5	True Random Number Generation	284
11.3	SE Mailbox	285
11.3.1	Sending Commands	285
11.3.2	Receiving Responses	285
11.3.3	MAILBOX Register Map	285
11.3.4	MAILBOX Register Description	286
12.	EMU - Energy Management Unit	288
12.1	Introduction	288
12.2	Features	289
12.3	Functional Description	290
12.3.1	Energy Modes	291
12.3.2	Entering Low Energy Modes	295
12.3.3	Exiting a Low Energy Mode	297
12.3.4	Power Domains	298
12.3.5	Voltage Scaling	298
12.3.6	EM0 / EM1 Peripheral Register Retention	299
12.3.7	Power Configurations	300
12.3.8	Buck DC-DC Interface	304
12.3.9	EFP01 Communication	307
12.3.10	Brown Out Detector (BOD)	308
12.3.11	Reset Management Unit	309
12.3.12	Temperature Sensor	311
12.3.13	Register Locks	312
12.4	EMU Register Map	313
12.5	EMU Register Description	316
12.5.1	EMU_DECBOB - DECOUPLE LVBOD Control Register	316
12.5.2	EMU_BOD3SENSE - BOD3SENSE Control Register	317
12.5.3	EMU_VREGVDDCMPCTRL - DC-DC VREGVDD Comparator Control Register	317
12.5.4	EMU_PD1PARETCTRL - PD1 Partial Retention Control	318
12.5.5	EMU_IPVERSION - IP Version	318
12.5.6	EMU_LOCK - EMU Configuration Lock Register	319
12.5.7	EMU_IF - Interrupt Flags	320
12.5.8	EMU_IEN - Interrupt Enables	321
12.5.9	EMU_EM4CTRL - EM4 Control	322
12.5.10	EMU_CMD - EMU Command Register	323
12.5.11	EMU_CTRL - EMU Control Register	324
12.5.12	EMU_TEMPLIMITS - EMU Temperature Thresholds	325
12.5.13	EMU_STATUS - EMU Status Register	326
12.5.14	EMU_TEMP - Temperature	327
12.5.15	EMU_RSTCTRL - Reset Management Control Register	328
12.5.16	EMU_RSTCAUSE - Reset Cause	330

12.5.17	EMU_TAMPERRSTCAUSE - Tamper Reset Cause	331
12.5.18	EMU_DGIF - Interrupt Flags Debug	332
12.5.19	EMU_DGIEN - Interrupt Enables Debug	333
12.5.20	EMU_EFPIF - EFP Interrupt Register	333
12.5.21	EMU_EFPIEN - EFP Interrupt Enable Register	334
12.6	DCDC Register Map	335
12.7	DCDC Register Description	336
12.7.1	DCDC_IPVERSION - IPVERSION	336
12.7.2	DCDC_CTRL - Control	337
12.7.3	DCDC_EM01CTRL0 - EM01 Control.	338
12.7.4	DCDC_EM23CTRL0 - EM23 Control.	339
12.7.5	DCDC_PFMXCTRL - PFMX Control Register	340
12.7.6	DCDC_IF - Interrupt Flags	341
12.7.7	DCDC_IEN - Interrupt Enable	342
12.7.8	DCDC_STATUS - Status Register	343
12.7.9	DCDC_SYNCBUSY - Syncbusy Status Register	344
12.7.10	DCDC_LOCK - Lock Register	345
12.7.11	DCDC_LOCKSTATUS - Lock Status Register	345
13.	PRS - Peripheral Reflex System	346
13.1	Introduction.	346
13.2	Features	346
13.3	Functional Description	347
13.3.1	Asynchronous Channel Functions.	347
13.3.2	Configurable Logic	348
13.3.3	Producers	349
13.3.4	Consumers	356
13.4	PRS Register Map	357
13.5	PRS Register Description	374
13.5.1	PRS_IPVERSION - PRS IPVERSION	374
13.5.2	PRS_ASYNC_SWPULSE - Software Pulse Register	375
13.5.3	PRS_ASYNC_SWLEVEL - Software Level Register	377
13.5.4	PRS_ASYNC_PEEK - Async Channel Values	379
13.5.5	PRS_SYNC_PEEK - Sync Channel Values	380
13.5.6	PRS_ASYNC_CHx_CTRL - Async Channel Control Register	381
13.5.7	PRS_SYNC_CHx_CTRL - Sync Channel Control Register	382
13.5.8	PRS_CONSUMER_CMU_CALDN - CALDN Consumer Register	383
13.5.9	PRS_CONSUMER_CMU_CALUP - CALUP Consumer Register	383
13.5.10	PRS_CONSUMER_EUSART0_CLK - CLK Consumer Register	384
13.5.11	PRS_CONSUMER_EUSART0_RX - RX Consumer Register	384
13.5.12	PRS_CONSUMER_EUSART0_TRIGGER - TRIGGER Consumer Register	385
13.5.13	PRS_CONSUMER_EUSART1_CLK - CLK Consumer Register	385
13.5.14	PRS_CONSUMER_EUSART1_RX - RX Consumer Register	386
13.5.15	PRS_CONSUMER_EUSART1_TRIGGER - TRIGGER Consumer Register	386
13.5.16	PRS_CONSUMER_IADC0_SCANTRIGGER - SCAN Consumer Register	387
13.5.17	PRS_CONSUMER_IADC0_SINGLETRIGGER - SINGLE Consumer Register	387
13.5.18	PRS_CONSUMER_LDMAXBAR_DMAREQ0 - DMAREQ0 Consumer Register	388

13.5.19	PRS_CONSUMER_LDMAXBAR_DMAREQ1 - DMAREQ1 Consumer Register	388
13.5.20	PRS_CONSUMER_LETIMER0_CLEAR - CLEAR Consumer Register	389
13.5.21	PRS_CONSUMER_LETIMER0_START - START Consumer Register	389
13.5.22	PRS_CONSUMER_LETIMER0_STOP - STOP Consumer Register	390
13.5.23	PRS_CONSUMER_MODEM_DIN - DIN Consumer Register	390
13.5.24	PRS_CONSUMER_MODEM_PAEN - PAEN Consumer Register	391
13.5.25	PRS_CONSUMER_PCNT0_S0IN - S0IN Consumer Register	391
13.5.26	PRS_CONSUMER_PCNT0_S1IN - S1IN Consumer Register	392
13.5.27	PRS_CONSUMER_RAC_CLR - CLR Consumer Register	392
13.5.28	PRS_CONSUMER_RAC_CTIIN0 - CTI Consumer Register	393
13.5.29	PRS_CONSUMER_RAC_CTIIN1 - CTI Consumer Register	393
13.5.30	PRS_CONSUMER_RAC_CTIIN2 - CTI Consumer Register	394
13.5.31	PRS_CONSUMER_RAC_CTIIN3 - CTI Consumer Register	394
13.5.32	PRS_CONSUMER_RAC_FORCETX - FORCETX Consumer Register	395
13.5.33	PRS_CONSUMER_RAC_RXDIS - RXDIS Consumer Register	395
13.5.34	PRS_CONSUMER_RAC_RXEN - RXEN Consumer Register	396
13.5.35	PRS_CONSUMER_RAC_TXEN - TXEN Consumer Register	396
13.5.36	PRS_CONSUMER_SETAMPER_TAMPERSRC25 - TAMPERSRC25 Consumer Register	397
13.5.37	PRS_CONSUMER_SETAMPER_TAMPERSRC26 - TAMPERSRC26 Consumer Register	397
13.5.38	PRS_CONSUMER_SETAMPER_TAMPERSRC27 - TAMPERSRC27 Consumer Register	398
13.5.39	PRS_CONSUMER_SETAMPER_TAMPERSRC28 - TAMPERSRC28 Consumer Register	398
13.5.40	PRS_CONSUMER_SETAMPER_TAMPERSRC29 - TAMPERSRC29 Consumer Register	399
13.5.41	PRS_CONSUMER_SETAMPER_TAMPERSRC30 - TAMPERSRC30 Consumer Register	399
13.5.42	PRS_CONSUMER_SETAMPER_TAMPERSRC31 - TAMPERSRC31 Consumer Register	400
13.5.43	PRS_CONSUMER_SYSRTC0_IN0 - IN0 Consumer Register	400
13.5.44	PRS_CONSUMER_SYSRTC0_IN1 - IN1 Consumer Register	401
13.5.45	PRS_CONSUMER_HFXO0_OSCREQ - OSCREQ Consumer Register	401
13.5.46	PRS_CONSUMER_HFXO0_TIMEOUT - TIMEOUT Consumer Register	402
13.5.47	PRS_CONSUMER_CORE_CTIIN0 - CTI0 Consumer Selection	402
13.5.48	PRS_CONSUMER_CORE_CTIIN1 - CTI1 Consumer Selection	403
13.5.49	PRS_CONSUMER_CORE_CTIIN2 - CTI2 Consumer Selection	403
13.5.50	PRS_CONSUMER_CORE_CTIIN3 - CTI3 Consumer Selection	404
13.5.51	PRS_CONSUMER_CORE_M33RXEV - M33 Consumer Selection	404
13.5.52	PRS_CONSUMER_TIMER0_CC0 - CC0 Consumer Register	405
13.5.53	PRS_CONSUMER_TIMER0_CC1 - CC1 Consumer Register	405
13.5.54	PRS_CONSUMER_TIMER0_CC2 - CC2 Consumer Register	406
13.5.55	PRS_CONSUMER_TIMER0_DTI - DTI Consumer Register	406
13.5.56	PRS_CONSUMER_TIMER0_DTIFS1 - DTI Consumer Register	407
13.5.57	PRS_CONSUMER_TIMER0_DTIFS2 - DTI Consumer Register	407
13.5.58	PRS_CONSUMER_TIMER1_CC0 - CC0 Consumer Register	408
13.5.59	PRS_CONSUMER_TIMER1_CC1 - CC1 Consumer Register	408
13.5.60	PRS_CONSUMER_TIMER1_CC2 - CC2 Consumer Register	409
13.5.61	PRS_CONSUMER_TIMER1_DTI - DTI Consumer Register	409
13.5.62	PRS_CONSUMER_TIMER1_DTIFS1 - DTI Consumer Register	410
13.5.63	PRS_CONSUMER_TIMER1_DTIFS2 - DTI Consumer Register	410
13.5.64	PRS_CONSUMER_TIMER2_CC0 - CC0 Consumer Register	411
13.5.65	PRS_CONSUMER_TIMER2_CC1 - CC1 Consumer Register	411
13.5.66	PRS_CONSUMER_TIMER2_CC2 - CC2 Consumer Register	412

13.5.67	PRS_CONSUMER_TIMER2_DTI - DTI Consumer Register	412
13.5.68	PRS_CONSUMER_TIMER2_DTIFS1 - DTI Consumer Register	413
13.5.69	PRS_CONSUMER_TIMER2_DTIFS2 - DTI Consumer Register	413
13.5.70	PRS_CONSUMER_TIMER3_CC0 - CC0 Consumer Register	414
13.5.71	PRS_CONSUMER_TIMER3_CC1 - CC1 Consumer Register	414
13.5.72	PRS_CONSUMER_TIMER3_CC2 - CC2 Consumer Register	415
13.5.73	PRS_CONSUMER_TIMER3_DTI - DTI Consumer Register	415
13.5.74	PRS_CONSUMER_TIMER3_DTIFS1 - DTI Consumer Register	416
13.5.75	PRS_CONSUMER_TIMER3_DTIFS2 - DTI Consumer Register	416
13.5.76	PRS_CONSUMER_TIMER4_CC0 - CC0 Consumer Register	417
13.5.77	PRS_CONSUMER_TIMER4_CC1 - CC1 Consumer Register	417
13.5.78	PRS_CONSUMER_TIMER4_CC2 - CC2 Consumer Register	418
13.5.79	PRS_CONSUMER_TIMER4_DTI - DTI Consumer Register	418
13.5.80	PRS_CONSUMER_TIMER4_DTIFS1 - DTI Consumer Register	419
13.5.81	PRS_CONSUMER_TIMER4_DTIFS2 - DTI Consumer Register	419
13.5.82	PRS_CONSUMER_USART0_CLK - CLK Consumer Register	420
13.5.83	PRS_CONSUMER_USART0_IR - IR Consumer Register	420
13.5.84	PRS_CONSUMER_USART0_RX - RX Consumer Register	421
13.5.85	PRS_CONSUMER_USART0_TRIGGER - TRIGGER Consumer Register	421
13.5.86	PRS_CONSUMER_VDAC0_ASYNCTRIGCH0 - ASYNCTRIG Consumer Register	422
13.5.87	PRS_CONSUMER_VDAC0_ASYNCTRIGCH1 - ASYNCTRIG Consumer Register	422
13.5.88	PRS_CONSUMER_VDAC0_SYNCTRIGCH0 - SYNCTRIG Consumer Register	423
13.5.89	PRS_CONSUMER_VDAC0_SYNCTRIGCH1 - SYNCTRIG Consumer Register	423
13.5.90	PRS_CONSUMER_VDAC1_ASYNCTRIGCH0 - ASYNCTRIG Consumer Register	424
13.5.91	PRS_CONSUMER_VDAC1_ASYNCTRIGCH1 - ASYNCTRIG Consumer Register	424
13.5.92	PRS_CONSUMER_VDAC1_SYNCTRIGCH0 - SYNCTRIG Consumer Register	425
13.5.93	PRS_CONSUMER_VDAC1_SYNCTRIGCH1 - SYNCTRIG Consumer Register	425
13.5.94	PRS_CONSUMER_WDOG0_SRC0 - SRC0 Consumer Register	426
13.5.95	PRS_CONSUMER_WDOG0_SRC1 - SRC1 Consumer Register	426
13.5.96	PRS_CONSUMER_WDOG1_SRC0 - SRC0 Consumer Register	427
13.5.97	PRS_CONSUMER_WDOG1_SRC1 - SRC1 Consumer Register	427
14.	GPCRC - General Purpose Cyclic Redundancy Check	428
14.1	Introduction	428
14.2	Features	428
14.3	Functional Description	429
14.3.1	Polynomial Specification	430
14.3.2	Input and Output Specification	430
14.3.3	Initialization	430
14.3.4	DMA Usage	430
14.3.5	Byte-Level Bit Reversal and Byte Reordering	431
14.4	GPCRC Register Map	434
14.5	GPCRC Register Description	435
14.5.1	GPCRC_IPVERSION - IP Version ID	435
14.5.2	GPCRC_EN - CRC Enable	436
14.5.3	GPCRC_CTRL - Control Register	437
14.5.4	GPCRC_CMD - Command Register	438

14.5.5	GPCRC_INIT - CRC Init Value	438
14.5.6	GPCRC_POLY - CRC Polynomial Value	439
14.5.7	GPCRC_INPUTDATA - Input 32-Bit Data Register	439
14.5.8	GPCRC_INPUTDATAHWORD - Input 16-Bit Data Register	440
14.5.9	GPCRC_INPUTDATABYTE - Input 8-Bit Data Register	440
14.5.10	GPCRC_DATA - CRC Data Register	441
14.5.11	GPCRC_DATAREV - CRC Data Reverse Register	441
14.5.12	GPCRC_DATABYTEREV - CRC Data Byte Reverse Register	442
15.	SYSRTC - System RTC	443
15.1	Introduction.	443
15.2	Features	443
15.3	Functional Description	443
15.3.1	Interrupts and Wake Events.	444
15.3.2	Counter	444
15.3.3	Compare Events	444
15.3.4	Capture Events	444
15.3.5	SYSRTC Behavior on SWRST/Disablement/STOP	444
15.3.6	Debug Functionality	445
15.4	SYSRTC Register Map	446
15.5	SYSRTC Register Description	448
15.5.1	SYSRTC_IPVERSION - IP VERSION	448
15.5.2	SYSRTC_EN - Module Enable Register	448
15.5.3	SYSRTC_SWRST - Software Reset Register	449
15.5.4	SYSRTC_CFG - Configuration Register	449
15.5.5	SYSRTC_CMD - Command Register	450
15.5.6	SYSRTC_STATUS - Status Register	450
15.5.7	SYSRTC_CNT - Counter Value Register	451
15.5.8	SYSRTC_SYNCBUSY - Synchronization Busy Register	451
15.5.9	SYSRTC_LOCK - Configuration Lock Register	452
15.5.10	SYSRTC_GRP0_IF - Group Interrupt Flags	452
15.5.11	SYSRTC_GRP0_IEN - Group Interrupt Enables	453
15.5.12	SYSRTC_GRP0_CTRL - Group Control Register	454
15.5.13	SYSRTC_GRP0_CMP0VALUE - Compare 0 Value Register	455
15.5.14	SYSRTC_GRP0_CMP1VALUE - Compare 1 Value Register	455
15.5.15	SYSRTC_GRP0_CAP0VALUE - Capture 0 Value Register	456
15.5.16	SYSRTC_GRP0_SYNCBUSY - Synchronization Busy Register	456
16.	BURTC - Back-Up Real Time Counter	457
16.1	Introduction.	457
16.2	Features	457
16.3	Functional Description	458
16.3.1	Clock Selection	458
16.3.2	Configuration	458
16.3.3	Debug Features and Description	458
16.3.4	Counter	459
16.3.5	Compare Channel	460

16.3.6	Interrupts	460
16.3.7	Register Lock	460
16.4	BURTC Register Map	461
16.5	BURTC Register Description	462
16.5.1	BURTC_IPVERSION - IP Version ID.	462
16.5.2	BURTC_EN - Module Enable Register	463
16.5.3	BURTC_CFG - Configuration Register	464
16.5.4	BURTC_CMD - Command Register	465
16.5.5	BURTC_STATUS - Status Register	466
16.5.6	BURTC_IF - Interrupt Flag Register	466
16.5.7	BURTC_IEN - Interrupt Enable Register	467
16.5.8	BURTC_PRECNT - Pre-Counter Value Register	467
16.5.9	BURTC_CNT - Counter Value Register	468
16.5.10	BURTC_EM4WUEN - EM4 Wakeup Request Enable Register	468
16.5.11	BURTC_SYNCBUSY - Synchronization Busy Register	469
16.5.12	BURTC_LOCK - Configuration Lock Register	470
16.5.13	BURTC_COMP - Compare Value Register	470
17.	BURAM - Backup RAM	471
17.1	Introduction.	471
17.2	Functional Description	471
17.3	BURAM Register Map	471
17.4	BURAM Register Description.	472
17.4.1	BURAM_RET _x _REG - Retention Register	472
18.	LETIMER - Low Energy Timer	473
18.1	Introduction.	473
18.2	Features	473
18.3	Functional Description	474
18.3.1	Internal Overview	475
18.3.2	Free Running Mode	476
18.3.3	One-shot Mode	477
18.3.4	Buffered Mode	478
18.3.5	Double Mode	479
18.4	Clock Frequency	480
18.5	PRS Input Triggers	481
18.6	Debug	481
18.7	Output Action	482
18.8	PRS Output	482
18.9	Interrupts	482
18.10	Using the LETIMER in EM3	482
18.11	Register Access.	482
18.12	Programmer's Model	483
18.12.1	Free Running Mode	483

18.12.2	One Shot Mode	484
18.12.3	DOUBLE Mode	484
18.12.4	BUFFERED Mode	485
18.12.5	Continuous Output Generation	486
18.12.6	PWM Output	487
18.13	LETIMER Register Map	488
18.14	LETIMER Register Description	490
18.14.1	LETIMER_IPVERSION - IP Version	490
18.14.2	LETIMER_EN - Module En	490
18.14.3	LETIMER_SWRST - Software Reset Register	491
18.14.4	LETIMER_CTRL - Control Register	492
18.14.5	LETIMER_CMD - Command Register	494
18.14.6	LETIMER_STATUS - Status Register	495
18.14.7	LETIMER_CNT - Counter Value Register	495
18.14.8	LETIMER_COMP0 - Compare Value Register 0	496
18.14.9	LETIMER_COMP1 - Compare Value Register 1	496
18.14.10	LETIMER_TOP - Counter TOP Value Register	497
18.14.11	LETIMER_TOPBUFF - Buffered Counter TOP Value	497
18.14.12	LETIMER_REP0 - Repeat Counter Register 0	498
18.14.13	LETIMER_REP1 - Repeat Counter Register 1	498
18.14.14	LETIMER_IF - Interrupt Flag Register	499
18.14.15	LETIMER_IEN - Interrupt Enable Register	500
18.14.16	LETIMER_LOCK - Configuration Lock Register	501
18.14.17	LETIMER_SYNCBUSY - Synchronization Busy Register	502
18.14.18	LETIMER_PRSMODE - PRS Input Mode Select Register	503
19.	TIMER - Timer/Counter	505
19.1	Introduction	505
19.2	Features	506
19.3	Functional Description	507
19.3.1	Register Access	507
19.3.2	Counter Modes	508
19.3.3	Compare/Capture Channels	514
19.3.4	Dead-Time Insertion Unit	525
19.3.5	Debug Mode	529
19.3.6	Interrupts, DMA and PRS Output	529
19.3.7	GPIO Input/Output	529
19.4	TIMER Register Map	530
19.5	TIMER Register Description	533
19.5.1	TIMER_IPVERSION - IP Version ID	533
19.5.2	TIMER_CFG - Configuration Register	534
19.5.3	TIMER_CTRL - Control Register	537
19.5.4	TIMER_CMD - Command Register	538
19.5.5	TIMER_STATUS - Status Register	539
19.5.6	TIMER_IF - Interrupt Flag Register	542
19.5.7	TIMER_IEN - Interrupt Enable Register	544
19.5.8	TIMER_TOP - Counter Top Value Register	545

19.5.9	TIMER_TOPB - Counter Top Value Buffer Register	545
19.5.10	TIMER_CNT - Counter Value Register	546
19.5.11	TIMER_LOCK - TIMER Configuration Lock Register	546
19.5.12	TIMER_EN - Module En	547
19.5.13	TIMER_CCx_CFG - CC Channel Configuration Register	548
19.5.14	TIMER_CCx_CTRL - CC Channel Control Register	550
19.5.15	TIMER_CCx_OC - OC Channel Value Register	551
19.5.16	TIMER_CCx_OCB - OC Channel Value Buffer Register	552
19.5.17	TIMER_CCx_ICF - IC Channel Value Register	552
19.5.18	TIMER_CCx_ICOF - IC Channel Value Overflow Register	552
19.5.19	TIMER_DTCFG - DTI Configuration Register	553
19.5.20	TIMER_DTIMECFG - DTI Time Configuration Register	554
19.5.21	TIMER_DTFCFG - DTI Fault Configuration Register	555
19.5.22	TIMER_DTCTRL - DTI Control Register	556
19.5.23	TIMER DTOGEN - DTI Output Generation Enable Register	557
19.5.24	TIMER_DTFAULT - DTI Fault Register	558
19.5.25	TIMER_DTFAULTC - DTI Fault Clear Register	559
19.5.26	TIMER_DTLOCK - DTI Configuration Lock Register	560
20.	USART - Universal Synchronous Asynchronous Receiver/Transmitter	561
20.1	Introduction.	561
20.2	Features	562
20.3	Functional Description	563
20.3.1	Modes of Operation	564
20.3.2	Asynchronous Operation	564
20.3.3	Synchronous Operation	580
20.3.4	Hardware Flow Control	586
20.3.5	Debug Halt	586
20.3.6	PRS-triggered Transmissions	586
20.3.7	PRS RX Input	586
20.3.8	PRS CLK Input	587
20.3.9	DMA Support	587
20.3.10	Timer	588
20.3.11	Interrupts	593
20.3.12	IrDA Modulator/ Demodulator	594
20.4	USART Register Map	595
20.5	USART Register Description	598
20.5.1	USART_IPVERSION - IPVERSION	598
20.5.2	USART_EN - USART Enable	598
20.5.3	USART_CTRL - Control Register	599
20.5.4	USART_FRAME - USART Frame Format Register	604
20.5.5	USART_TRIGCTRL - USART Trigger Control Register	606
20.5.6	USART_CMD - Command Register	607
20.5.7	USART_STATUS - USART Status Register	609
20.5.8	USART_CLKDIV - Clock Control Register	610
20.5.9	USART_RXDATAEXT - RX Buffer Data Extended Register	611
20.5.10	USART_RXDATA - RX Buffer Data Register	611

20.5.11	USART_RXDOUBLEX - RX Buffer Double Data Extended Register	612
20.5.12	USART_RXDOUBLE - RX FIFO Double Data Register	613
20.5.13	USART_RXDATAEXP - RX Buffer Data Extended Peek Register	613
20.5.14	USART_RXDOUBLEXP - RX Buffer Double Data Extended Peek R...	614
20.5.15	USART_TXDATA - TX Buffer Data Extended Register	615
20.5.16	USART_TXDATA - TX Buffer Data Register	616
20.5.17	USART_TXDOUBLEX - TX Buffer Double Data Extended Register	617
20.5.18	USART_TXDOUBLE - TX Buffer Double Data Register	618
20.5.19	USART_IF - Interrupt Flag Register.	619
20.5.20	USART_IEN - Interrupt Enable Register	621
20.5.21	USART_IRCTRL - IrDA Control Register	622
20.5.22	USART_I2SCTRL - I2S Control Register	623
20.5.23	USART_TIMING - Timing Register	625
20.5.24	USART_CTRLX - Control Register Extended	627
20.5.25	USART_TIMECMP0 - Timer Compare 0	629
20.5.26	USART_TIMECMP1 - Timer Compare 1	631
20.5.27	USART_TIMECMP2 - Timer Compare 2	633
21.	EUSART - Universal Synchronous Asynchronous Receiver/Transmitter	635
21.1	Introduction.	635
21.2	Features	636
21.3	Functional Description	637
21.3.1	Modes of Operation	638
21.3.2	Asynchronous Operation	638
21.3.3	Synchronous Operation	659
21.3.4	Debug Halt	662
21.3.5	PRS-triggered Transmissions	662
21.3.6	PRS RX Input	663
21.3.7	PRS CLK Input	663
21.3.8	DMA Support	663
21.4	EUSART Register Map.	664
21.5	EUSART Register Description	667
21.5.1	EUSART_IPVERSION - IP Version ID	667
21.5.2	EUSART_EN - Enable Register	667
21.5.3	EUSART_CFG0 - Configuration 0 Register	668
21.5.4	EUSART_CFG1 - Configuration 1 Register	671
21.5.5	EUSART_CFG2 - Configuration 2 Register	676
21.5.6	EUSART_FRAMECFG - Frame Format Register	678
21.5.7	EUSART_DTXDATCFG - Default TX DATA Register	679
21.5.8	EUSART_IRHFCFG - HF IrDA Mod Config Register	680
21.5.9	EUSART_IRLFCFG - LF IrDA Pulse Config Register	681
21.5.10	EUSART_TIMINGCFG - Timing Register	682
21.5.11	EUSART_STARTFRAMECFG - Start Frame Register	684
21.5.12	EUSART_SIGFRAMECFG - Signal Frame Register	684
21.5.13	EUSART_CLKDIV - Clock Divider Register	685
21.5.14	EUSART_TRIGCTRL - Trigger Control Register	685
21.5.15	EUSART_CMD - Command Register	686

21.5.16	EUSART_RXDATA - RX Data Register	687
21.5.17	EUSART_RXDATAP - RX Data Peek Register	687
21.5.18	EUSART_TXDATA - TX Data Register	688
21.5.19	EUSART_STATUS - Status Register	689
21.5.20	EUSART_IF - Interrupt Flag Register	691
21.5.21	EUSART_IEN - Interrupt Enable Register	693
21.5.22	EUSART_SYNCBUSY - Synchronization Busy Register	695
21.5.23	EUSART_DALICFG - DALI Config Register	697
22.	I2C - Inter-Integrated Circuit Interface	700
22.1	Introduction	700
22.2	Features	700
22.3	Functional Description	701
22.3.1	I2C-Bus Overview	702
22.3.2	Enable and Reset	706
22.3.3	Pin Configuration	706
22.3.4	Safely Disabling and Changing Follower Configuration	706
22.3.5	Clock Generation	707
22.3.6	Arbitration	707
22.3.7	Buffers	707
22.3.8	Leader Operation	710
22.3.9	Bus States	718
22.3.10	Follower Operation	718
22.3.11	Transfer Automation	722
22.3.12	Using 10-bit Addresses	723
22.3.13	Error Handling	723
22.3.14	DMA Support	725
22.3.15	Interrupts	725
22.3.16	Wake-up	725
22.4	I2C Register Map	726
22.5	I2C Register Description	728
22.5.1	I2C_IPVERSION - IP VERSION Register	728
22.5.2	I2C_EN - Enable Register	728
22.5.3	I2C_CTRL - Control Register	729
22.5.4	I2C_CMD - Command Register	733
22.5.5	I2C_STATE - State Register	734
22.5.6	I2C_STATUS - Status Register	735
22.5.7	I2C_CLKDIV - Clock Division Register	736
22.5.8	I2C_SADDR - Follower Address Register	736
22.5.9	I2C_SADDRMASK - Follower Address Mask Register	737
22.5.10	I2C_RXDATA - Receive Buffer Data Register	737
22.5.11	I2C_RXDOUBLE - Receive Buffer Double Data Register	738
22.5.12	I2C_RXDATAP - Receive Buffer Data Peek Register	738
22.5.13	I2C_RXDOUBLEP - Receive Buffer Double Data Peek Register	739
22.5.14	I2C_TXDATA - Transmit Buffer Data Register	739
22.5.15	I2C_TXDOUBLE - Transmit Buffer Double Data Register	740
22.5.16	I2C_IF - Interrupt Flag Register	741

22.5.17 I2C_IEN - Interrupt Enable Register	743
23. IADC - Incremental Analog to Digital Converter	745
23.1 Introduction.	745
23.2 Features	746
23.3 Functional Description	747
23.3.1 Register Access.	748
23.3.2 Clocking	749
23.3.3 Conversion Timing	750
23.3.4 Reference Selection and Analog Gain	759
23.3.5 Input and Configuration Selection	760
23.3.6 Gain and Offset Correction	765
23.3.7 Output Data FIFOs.	770
23.3.8 Window Compare	773
23.3.9 Interrupts	774
23.4 IADC Register Map	775
23.5 IADC Register Description.	778
23.5.1 IADC_IPVERSION - IPVERSION	778
23.5.2 IADC_EN - Enable	778
23.5.3 IADC_CTRL - Control	779
23.5.4 IADC_CMD - Command	781
23.5.5 IADC_TIMER - Timer	782
23.5.6 IADC_STATUS - Status	783
23.5.7 IADC_MASKREQ - Mask Request	784
23.5.8 IADC_STMASK - Scan Table Mask	785
23.5.9 IADC_CMPTHR - Digital Window Comparator Threshold	785
23.5.10 IADC_IF - Interrupt Flags	786
23.5.11 IADC_IEN - Interrupt Enable	788
23.5.12 IADC_TRIGGER - Trigger	790
23.5.13 IADC_CFGx - Configuration	793
23.5.14 IADC_SCALEx - Scaling	795
23.5.15 IADC_SCHEx - Scheduling	796
23.5.16 IADC_SINGLEFIFOCFG - Single FIFO Configuration	797
23.5.17 IADC_SINGLEFIFODATA - Single FIFO DATA	798
23.5.18 IADC_SINGLEFIFOSTAT - Single FIFO Status	799
23.5.19 IADC_SINGLEDATA - Single Data	799
23.5.20 IADC_SCANFIFOCFG - Scan FIFO Configuration.	800
23.5.21 IADC_SCANFIFODATA - Scan FIFO Read Data	801
23.5.22 IADC_SCANFIFOSTAT - Scan FIFO Status	802
23.5.23 IADC_SCANDATA - Scan Data	802
23.5.24 IADC_SINGLE - Single Queue Port Selection	803
23.5.25 IADC_SCANx - SCAN Entry	805
24. GPIO - General Purpose Input/Output	807
24.1 Introduction	807
24.2 Features	808
24.3 Functional Description	809

24.3.1	Pin Configuration	810
24.3.2	Alternate Port Control	812
24.3.3	Slew Rate	812
24.3.4	Input Disable	812
24.3.5	Configuration Lock	812
24.3.6	EM2 Functionality	812
24.3.7	EM4 Functionality	812
24.3.8	EM4 Wakeup	813
24.3.9	Debug Connections	813
24.3.10	Interrupt Generation	814
24.3.11	Output to PRS	815
24.3.12	Peripheral Resource Routing	815
24.4	Synchronization	823
24.5	GPIO Register Map	824
24.6	GPIO Register Description	849
24.6.1	GPIO_IPVERSION - Main	849
24.6.2	GPIO_PORTA_CTRL - Port Control	850
24.6.3	GPIO_PORTA_MODEL - Mode Low	851
24.6.4	GPIO_PORTA_MODEH - Mode High	856
24.6.5	GPIO_PORTA_DOUT - Data Out	857
24.6.6	GPIO_PORTA_DIN - Data in	858
24.6.7	GPIO_PORTB_CTRL - Port Control	859
24.6.8	GPIO_PORTB_MODEL - Mode Low	860
24.6.9	GPIO_PORTB_DOUT - Data Out	863
24.6.10	GPIO_PORTB_DIN - Data in	864
24.6.11	GPIO_PORTC_CTRL - Port Control	865
24.6.12	GPIO_PORTC_MODEL - Mode Low	866
24.6.13	GPIO_PORTC_MODEH - Mode High	871
24.6.14	GPIO_PORTC_DOUT - Data Out	872
24.6.15	GPIO_PORTC_DIN - Data in	873
24.6.16	GPIO_PORTD_CTRL - Port Control	874
24.6.17	GPIO_PORTD_MODEL - Mode Low	875
24.6.18	GPIO_PORTD_DOUT - Data Out	878
24.6.19	GPIO_PORTD_DIN - Data in	879
24.6.20	GPIO_LOCK - Lock Register	879
24.6.21	GPIO_GPILOCKSTATUS - Lock Status	880
24.6.22	GPIO_ABUSALLOC - A Bus Allocation	881
24.6.23	GPIO_BBUSALLOC - B Bus Allocation	883
24.6.24	GPIO_CDBUSALLOC - CD Bus Allocation	885
24.6.25	GPIO_EXTIPSELL - External Interrupt Port Select Low	887
24.6.26	GPIO_EXTIPSELH - External Interrupt Port Select High	890
24.6.27	GPIO_EXTIPINSELL - External Interrupt Pin Select Low	892
24.6.28	GPIO_EXTIPINSELH - External Interrupt Pin Select High	895
24.6.29	GPIO_EXTIRISE - External Interrupt Rising Edge Trigger	896
24.6.30	GPIO_EXTIFALL - External Interrupt Falling Edge Trigger	897
24.6.31	GPIO_IF - Interrupt Flag	898
24.6.32	GPIO_IEN - Interrupt Enable	900

24.6.33	GPIO_EM4WUEN - EM4 Wakeup Enable	902
24.6.34	GPIO_EM4WUPOL - EM4 Wakeup Polarity	902
24.6.35	GPIO_DBGROUTE PEN - Debugger Route Pin Enable	903
24.6.36	GPIO_TRACEROUTE PEN - Trace Route Pin Enable	904
24.6.37	GPIO_ACMP0_ROUTEEN - ACMP0 Pin Enable	905
24.6.38	GPIO_ACMP0_ACMPOUTROUTE - ACMPOUT Port/Pin Select	905
24.6.39	GPIO_ACMP1_ROUTEEN - ACMP1 Pin Enable	906
24.6.40	GPIO_ACMP1_ACMPOUTROUTE - ACMPOUT Port/Pin Select	906
24.6.41	GPIO_CMU_ROUTEEN - CMU Pin Enable	907
24.6.42	GPIO_CMU_CLKIN0ROUTE - CLKIN0 Port/Pin Select	907
24.6.43	GPIO_CMU_CLKOUT0ROUTE - CLKOUT0 Port/Pin Select	908
24.6.44	GPIO_CMU_CLKOUT1ROUTE - CLKOUT1 Port/Pin Select	908
24.6.45	GPIO_CMU_CLKOUT2ROUTE - CLKOUT2 Port/Pin Select	909
24.6.46	GPIO_EUSART0_ROUTEEN - EUSART0 Pin Enable	910
24.6.47	GPIO_EUSART0_CSROUTE - CS Port/Pin Select	911
24.6.48	GPIO_EUSART0_CTSROUTE - CTS Port/Pin Select	911
24.6.49	GPIO_EUSART0_RTSMROUTE - RTS Port/Pin Select	912
24.6.50	GPIO_EUSART0_RXROUTE - RX Port/Pin Select	912
24.6.51	GPIO_EUSART0_SCLKROUTE - SCLK Port/Pin Select	913
24.6.52	GPIO_EUSART0_TXROUTE - TX Port/Pin Select	913
24.6.53	GPIO_EUSART1_ROUTEEN - EUSART1 Pin Enable	914
24.6.54	GPIO_EUSART1_CSROUTE - CS Port/Pin Select	915
24.6.55	GPIO_EUSART1_CTSROUTE - CTS Port/Pin Select	915
24.6.56	GPIO_EUSART1_RTSMROUTE - RTS Port/Pin Select	916
24.6.57	GPIO_EUSART1_RXROUTE - RX Port/Pin Select	916
24.6.58	GPIO_EUSART1_SCLKROUTE - SCLK Port/Pin Select	917
24.6.59	GPIO_EUSART1_TXROUTE - TX Port/Pin Select	917
24.6.60	GPIO_FRC_ROUTEEN - FRC Pin Enable	918
24.6.61	GPIO_FRC_DCLKROUTE - DCLK Port/Pin Select	918
24.6.62	GPIO_FRC_DFRAMERROUTE - DFRAME Port/Pin Select	919
24.6.63	GPIO_FRC_DOUTROUTE - DOUT Port/Pin Select	919
24.6.64	GPIO_I2C0_ROUTEEN - I2C0 Pin Enable	920
24.6.65	GPIO_I2C0_SCLROUTE - SCL Port/Pin Select	920
24.6.66	GPIO_I2C0_SDAROUTE - SDA Port/Pin Select	921
24.6.67	GPIO_I2C1_ROUTEEN - I2C1 Pin Enable	921
24.6.68	GPIO_I2C1_SCLROUTE - SCL Port/Pin Select	922
24.6.69	GPIO_I2C1_SDAROUTE - SDA Port/Pin Select	922
24.6.70	GPIO_KEYSCAN_ROUTEEN - KEYSKAN Pin Enable	923
24.6.71	GPIO_KEYSCAN_COLOUT0ROUTE - COLOUT0 Port/Pin Select	924
24.6.72	GPIO_KEYSCAN_COLOUT1ROUTE - COLOUT1 Port/Pin Select	924
24.6.73	GPIO_KEYSCAN_COLOUT2ROUTE - COLOUT2 Port/Pin Select	925
24.6.74	GPIO_KEYSCAN_COLOUT3ROUTE - COLOUT3 Port/Pin Select	925
24.6.75	GPIO_KEYSCAN_COLOUT4ROUTE - COLOUT4 Port/Pin Select	926
24.6.76	GPIO_KEYSCAN_COLOUT5ROUTE - COLOUT5 Port/Pin Select	926
24.6.77	GPIO_KEYSCAN_COLOUT6ROUTE - COLOUT6 Port/Pin Select	927
24.6.78	GPIO_KEYSCAN_COLOUT7ROUTE - COLOUT7 Port/Pin Select	927
24.6.79	GPIO_KEYSCAN_ROWSENSE0ROUTE - ROWSENSE0 Port/Pin Select	928
24.6.80	GPIO_KEYSCAN_ROWSENSE1ROUTE - ROWSENSE1 Port/Pin Select	928

24.6.81	GPIO_KEYSCAN_ROWSENSE2ROUTE - ROWSENSE2 Port/Pin Select	929
24.6.82	GPIO_KEYSCAN_ROWSENSE3ROUTE - ROWSENSE3 Port/Pin Select	929
24.6.83	GPIO_KEYSCAN_ROWSENSE4ROUTE - ROWSENSE4 Port/Pin Select	930
24.6.84	GPIO_KEYSCAN_ROWSENSE5ROUTE - ROWSENSE5 Port/Pin Select	930
24.6.85	GPIO_LETIMER_ROUTEEN - LETIMER Pin Enable	931
24.6.86	GPIO_LETIMER_OUT0ROUTE - OUT0 Port/Pin Select	931
24.6.87	GPIO_LETIMER_OUT1ROUTE - OUT1 Port/Pin Select	932
24.6.88	GPIO_MODEM_ROUTEEN - MODEM Pin Enable	933
24.6.89	GPIO_MODEM_ANT0ROUTE - ANT0 Port/Pin Select	934
24.6.90	GPIO_MODEM_ANT1ROUTE - ANT1 Port/Pin Select	935
24.6.91	GPIO_MODEM_ANTROLLOVERROUTE - ANTROLLOVER Port/Pin Select	935
24.6.92	GPIO_MODEM_ANTRR0ROUTE - ANTRR0 Port/Pin Select	936
24.6.93	GPIO_MODEM_ANTRR1ROUTE - ANTRR1 Port/Pin Select	936
24.6.94	GPIO_MODEM_ANTRR2ROUTE - ANTRR2 Port/Pin Select	937
24.6.95	GPIO_MODEM_ANTRR3ROUTE - ANTRR3 Port/Pin Select	937
24.6.96	GPIO_MODEM_ANTRR4ROUTE - ANTRR4 Port/Pin Select	938
24.6.97	GPIO_MODEM_ANTRR5ROUTE - ANTRR5 Port/Pin Select	938
24.6.98	GPIO_MODEM_ANTSWENROUTE - ANTSWEN Port/Pin Select	939
24.6.99	GPIO_MODEM_ANTSWUSROUTE - ANTSWUS Port/Pin Select	939
24.6.100	GPIO_MODEM_ANTTRIGROUTE - ANTTRIG Port/Pin Select	940
24.6.101	GPIO_MODEM_ANTTRIGSTOPROUTE - ANTTRIGSTOP Port/Pin Select	940
24.6.102	GPIO_MODEM_DCLKROUTE - DCLK Port/Pin Select	941
24.6.103	GPIO_MODEM_DINROUTE - DIN Port/Pin Select	941
24.6.104	GPIO_MODEM_DOUTROUTE - DOUT Port/Pin Select	942
24.6.105	GPIO_PCNT0_S0INROUTE - S0IN Port/Pin Select	942
24.6.106	GPIO_PCNT0_S1INROUTE - S1IN Port/Pin Select	943
24.6.107	GPIO_PRS0_ROUTEEN - PRS0 Pin Enable	944
24.6.108	GPIO_PRS0_ASYNCH0ROUTE - ASYNCH0 Port/Pin Select	945
24.6.109	GPIO_PRS0_ASYNCH1ROUTE - ASYNCH1 Port/Pin Select	946
24.6.110	GPIO_PRS0_ASYNCH2ROUTE - ASYNCH2 Port/Pin Select	946
24.6.111	GPIO_PRS0_ASYNCH3ROUTE - ASYNCH3 Port/Pin Select	947
24.6.112	GPIO_PRS0_ASYNCH4ROUTE - ASYNCH4 Port/Pin Select	947
24.6.113	GPIO_PRS0_ASYNCH5ROUTE - ASYNCH5 Port/Pin Select	948
24.6.114	GPIO_PRS0_ASYNCH6ROUTE - ASYNCH6 Port/Pin Select	948
24.6.115	GPIO_PRS0_ASYNCH7ROUTE - ASYNCH7 Port/Pin Select	949
24.6.116	GPIO_PRS0_ASYNCH8ROUTE - ASYNCH8 Port/Pin Select	949
24.6.117	GPIO_PRS0_ASYNCH9ROUTE - ASYNCH9 Port/Pin Select	950
24.6.118	GPIO_PRS0_ASYNCH10ROUTE - ASYNCH10 Port/Pin Select	950
24.6.119	GPIO_PRS0_ASYNCH11ROUTE - ASYNCH11 Port/Pin Select	951
24.6.120	GPIO_PRS0_ASYNCH12ROUTE - ASYNCH12 Port/Pin Select	951
24.6.121	GPIO_PRS0_ASYNCH13ROUTE - ASYNCH13 Port/Pin Select	952
24.6.122	GPIO_PRS0_ASYNCH14ROUTE - ASYNCH14 Port/Pin Select	952
24.6.123	GPIO_PRS0_ASYNCH15ROUTE - ASYNCH15 Port/Pin Select	953
24.6.124	GPIO_PRS0_SYNCH0ROUTE - SYNCH0 Port/Pin Select	953
24.6.125	GPIO_PRS0_SYNCH1ROUTE - SYNCH1 Port/Pin Select	954
24.6.126	GPIO_PRS0_SYNCH2ROUTE - SYNCH2 Port/Pin Select	954
24.6.127	GPIO_PRS0_SYNCH3ROUTE - SYNCH3 Port/Pin Select	955
24.6.128	GPIO_RAC_ROUTEEN - RAC Pin Enable	955

24.6.129	GPIO_RAC_LNAENROUTE - LNAEN Port/Pin Select	956
24.6.130	GPIO_RAC_PAENROUTE - PAEN Port/Pin Select	956
24.6.131	GPIO_SYX00_BUFOUTREQINASYNCROUTE - BUFOUTREQINASYNC Port/Pin Select	957
24.6.132	GPIO_TIMER0_ROUTEEN - TIMER0 Pin Enable	958
24.6.133	GPIO_TIMER0_CC0ROUTE - CC0 Port/Pin Select	959
24.6.134	GPIO_TIMER0_CC1ROUTE - CC1 Port/Pin Select	959
24.6.135	GPIO_TIMER0_CC2ROUTE - CC2 Port/Pin Select	960
24.6.136	GPIO_TIMER0_CDTI0ROUTE - CDTI0 Port/Pin Select	960
24.6.137	GPIO_TIMER0_CDTI1ROUTE - CDTI1 Port/Pin Select	961
24.6.138	GPIO_TIMER0_CDTI2ROUTE - CDTI2 Port/Pin Select	961
24.6.139	GPIO_TIMER1_ROUTEEN - TIMER1 Pin Enable	962
24.6.140	GPIO_TIMER1_CC0ROUTE - CC0 Port/Pin Select	963
24.6.141	GPIO_TIMER1_CC1ROUTE - CC1 Port/Pin Select	963
24.6.142	GPIO_TIMER1_CC2ROUTE - CC2 Port/Pin Select	964
24.6.143	GPIO_TIMER1_CDTI0ROUTE - CDTI0 Port/Pin Select	964
24.6.144	GPIO_TIMER1_CDTI1ROUTE - CDTI1 Port/Pin Select	965
24.6.145	GPIO_TIMER1_CDTI2ROUTE - CDTI2 Port/Pin Select	965
24.6.146	GPIO_TIMER2_ROUTEEN - TIMER2 Pin Enable	966
24.6.147	GPIO_TIMER2_CC0ROUTE - CC0 Port/Pin Select	967
24.6.148	GPIO_TIMER2_CC1ROUTE - CC1 Port/Pin Select	967
24.6.149	GPIO_TIMER2_CC2ROUTE - CC2 Port/Pin Select	968
24.6.150	GPIO_TIMER2_CDTI0ROUTE - CDTI0 Port/Pin Select	968
24.6.151	GPIO_TIMER2_CDTI1ROUTE - CDTI1 Port/Pin Select	969
24.6.152	GPIO_TIMER2_CDTI2ROUTE - CDTI2 Port/Pin Select	969
24.6.153	GPIO_TIMER3_ROUTEEN - TIMER3 Pin Enable	970
24.6.154	GPIO_TIMER3_CC0ROUTE - CC0 Port/Pin Select	971
24.6.155	GPIO_TIMER3_CC1ROUTE - CC1 Port/Pin Select	971
24.6.156	GPIO_TIMER3_CC2ROUTE - CC2 Port/Pin Select	972
24.6.157	GPIO_TIMER3_CDTI0ROUTE - CDTI0 Port/Pin Select	972
24.6.158	GPIO_TIMER3_CDTI1ROUTE - CDTI1 Port/Pin Select	973
24.6.159	GPIO_TIMER3_CDTI2ROUTE - CDTI2 Port/Pin Select	973
24.6.160	GPIO_TIMER4_ROUTEEN - TIMER4 Pin Enable	974
24.6.161	GPIO_TIMER4_CC0ROUTE - CC0 Port/Pin Select	975
24.6.162	GPIO_TIMER4_CC1ROUTE - CC1 Port/Pin Select	975
24.6.163	GPIO_TIMER4_CC2ROUTE - CC2 Port/Pin Select	976
24.6.164	GPIO_TIMER4_CDTI0ROUTE - CDTI0 Port/Pin Select	976
24.6.165	GPIO_TIMER4_CDTI1ROUTE - CDTI1 Port/Pin Select	977
24.6.166	GPIO_TIMER4_CDTI2ROUTE - CDTI2 Port/Pin Select	977
24.6.167	GPIO_USART0_ROUTEEN - USART0 Pin Enable	978
24.6.168	GPIO_USART0_CSROUTE - CS Port/Pin Select	979
24.6.169	GPIO_USART0_CTSROUTE - CTS Port/Pin Select	979
24.6.170	GPIO_USART0_RTROUTE - RTS Port/Pin Select	980
24.6.171	GPIO_USART0_RXROUTE - RX Port/Pin Select	980
24.6.172	GPIO_USART0_CLKROUTE - SCLK Port/Pin Select	981
24.6.173	GPIO_USART0_TXROUTE - TX Port/Pin Select	981

25. LDMA - Linked DMA **982**

25.1	Introduction.	982
------	---------------	-----

25.1.1 Features983
25.2 Block Diagram.	984
25.3 Functional Description	985
25.3.1 Channel Descriptor	985
25.3.2 Channel Configuration	990
25.3.3 Channel Select Configuration	990
25.3.4 Starting a Transfer	990
25.3.5 Managing Transfer Errors	991
25.3.6 Arbitration	991
25.3.7 Channel Descriptor Data Structure	993
25.3.8 Interaction with the EMU	996
25.3.9 Interrupts	997
25.3.10 Debugging	997
25.4 Examples	997
25.4.1 Single Direct Register DMA Transfer.	997
25.4.2 Descriptor Linked List	998
25.4.3 Single Descriptor Looped Transfer	1000
25.4.4 Descriptor List with Looping	1001
25.4.5 Simple Inter-Channel Synchronization	1002
25.4.6 2D Copy	1004
25.4.7 Ping-Pong	1006
25.4.8 Scatter-Gather	1007
25.5 LDMA Source Selection Details	1007
25.5.1 LDMA Source Selection Details	1008
25.6 LDMA Register Map	1010
25.7 LDMA Register Description	1013
25.7.1 LDMA_IPVERSION - IP Version	1013
25.7.2 LDMA_EN - DMA Module Enable Disable Register	1013
25.7.3 LDMA_CTRL - DMA Control Register	1014
25.7.4 LDMA_STATUS - DMA Status Register.	1015
25.7.5 LDMA_SYNCSET - DMA Sync Trig Sw Set Register	1016
25.7.6 LDMA_SYNCCLR - DMA Sync Trig Sw Clear Register	1016
25.7.7 LDMA_SYNCHWEN - DMA Sync HW Trigger Enable Register	1017
25.7.8 LDMA_SYNCHWSEL - DMA Sync HW Trigger Selection Register	1018
25.7.9 LDMA_SYNCSTATUS - DMA Sync Trigger Status Register	1019
25.7.10 LDMA_CHEN - DMA Channel Enable Register	1019
25.7.11 LDMA_CHDIS - DMA Channel Disable Register	1020
25.7.12 LDMA_CHSTATUS - DMA Channel Status Register	1020
25.7.13 LDMA_CHBUSY - DMA Channel Busy Register	1021
25.7.14 LDMA_CHDONE - DMA Channel Linking Done Register	1022
25.7.15 LDMA_DBGHALT - DMA Channel Debug Halt Register	1023
25.7.16 LDMA_SWREQ - DMA Channel Software Transfer Request	1023
25.7.17 LDMA_REQDIS - DMA Channel Request Disable Register	1024
25.7.18 LDMA_REQPEND - DMA Channel Requests Pending Register	1024
25.7.19 LDMA_LINKLOAD - DMA Channel Link Load Register	1025
25.7.20 LDMA_REQCLEAR - DMA Channel Request Clear Register	1025
25.7.21 LDMA_IF - Interrupt Flag Register	1026

25.7.22	LDMA_IEN - Interrupt Enable Register	1027
25.7.23	LDMA_CHx_CFG - Channel Configuration Register	1028
25.7.24	LDMA_CHx_LOOP - Channel Loop Counter Register	1029
25.7.25	LDMA_CHx_CTRL - Channel Descriptor Control Word Register	1030
25.7.26	LDMA_CHx_SRC - Channel Descriptor Source Address	1033
25.7.27	LDMA_CHx_DST - Channel Descriptor Destination Address	1033
25.7.28	LDMA_CHx_LINK - Channel Descriptor Link Address	1034
25.8	LDMAXBAR Register Map	1034
25.9	LDMAXBAR Register Description	1035
25.9.1	LDMAXBAR_IPVERSION - IP Veersion ID	1035
25.9.2	LDMAXBAR_CHx_REQSEL - Channel Peripheral Request Select Reg...	1035
26.	WDOG - Watch Dog Timer	1036
26.1	Introduction	1036
26.2	Features	1036
26.3	Functional Description	1037
26.3.1	Clock Source	1037
26.3.2	Debug Functionality	1037
26.3.3	Energy Mode Handling	1037
26.3.4	Warning Interrupt	1037
26.3.5	Window Interrupt	1038
26.3.6	PRS as Watchdog Clear	1039
26.3.7	PRS Rising Edge Monitoring	1039
26.4	WDOG Register Map	1040
26.5	WDOG Register Description	1041
26.5.1	WDOG_IPVERSION - IP Version Register	1041
26.5.2	WDOG_EN - Enable Register	1041
26.5.3	WDOG_CFG - Configuration Register	1042
26.5.4	WDOG_CMD - Command Register	1045
26.5.5	WDOG_STATUS - Status Register	1045
26.5.6	WDOG_IF - Interrupt Flag Register	1046
26.5.7	WDOG_IEN - Interrupt Enable Register	1047
26.5.8	WDOG_LOCK - Lock Register	1048
26.5.9	WDOG_SYNCBUSY - Synchronization Busy Register	1048
27.	PCNT - Pulse Counter	1049
27.1	Introduction.	1049
27.2	Features	1049
27.3	Functional Description	1050
27.3.1	Pulse Counter Modes	1050
27.3.2	Hysteresis	1057
27.3.3	Auxiliary Counter	1058
27.3.4	Register Access.	1058
27.3.5	Clock Sources	1058
27.3.6	Input Filter	1059
27.3.7	Edge Polarity	1059

27.3.8	PRS and PCNTn_S0IN,PCNTn_S1IN Inputs1059
27.3.9	Interrupts1059
27.4	PCNT Register Map1061
27.5	PCNT Register Description1063
27.5.1	PCNT_IPVERSION - IP Version ID1063
27.5.2	PCNT_EN - Module Enable Register.1063
27.5.3	PCNT_SWRST - Software Reset Register1064
27.5.4	PCNT_CFG - Configuration Register.1065
27.5.5	PCNT_CTRL - Control Register1067
27.5.6	PCNT_CMD - Command Register1069
27.5.7	PCNT_STATUS - Status Register.1070
27.5.8	PCNT_IF - Interrupt Flag Register1071
27.5.9	PCNT_IEN - Interrupt Enable Register1072
27.5.10	PCNT_CNT - Counter Value Register1072
27.5.11	PCNT_AUXCNT - Auxiliary Counter Value Register1073
27.5.12	PCNT_TOP - Top Value Register1073
27.5.13	PCNT_TOPB - Counter Top Value Buffer Register1074
27.5.14	PCNT_OVSCTRL - Oversampling Control Register1074
27.5.15	PCNT_SYNCBUSY - Synchronization Busy Register1075
27.5.16	PCNT_LOCK - Configuration Lock Register1076
28.	VDAC - Digital to Analog Converter1077
28.1	Introduction.1077
28.2	Features1078
28.3	Functional Description1079
28.3.1	Power Supply1079
28.3.2	I/O Pin Considerations1079
28.3.3	Enabling and Disabling a Channel1080
28.3.4	Clock Selection1081
28.3.5	Conversions1082
28.3.6	Conversion Trigger.1083
28.3.7	Refresh Trigger1083
28.3.8	PRS Communication1083
28.3.9	Reference Selection1084
28.3.10	Power Modes1084
28.3.11	Warmup Time and Initial Conversion1084
28.3.12	Output Mode1085
28.3.13	Internal Timers.1085
28.3.14	FIFO1086
28.3.15	Keepwarm Sub-modes1086
28.3.16	LDMA Interface1086
28.3.17	Sine Generation Mode1087
28.3.18	Interrupts and Wakeup1088
28.3.19	VDAC Output Configuration1089
28.4	VDAC Register Map1090
28.5	VDAC Register Description1091
28.5.1	VDAC_IPVERSION - IPVERSION1091

28.5.2	VDAC_EN - Module Enable1092
28.5.3	VDAC_SWRST - Software Reset Register1092
28.5.4	VDAC_CFG - Config Register1093
28.5.5	VDAC_STATUS - Status Register1096
28.5.6	VDAC_CH0CFG - Channel 0 Config Register.1098
28.5.7	VDAC_CH1CFG - Channel 1 Config Register.1100
28.5.8	VDAC_CMD - Command Register1102
28.5.9	VDAC_IF - Interrupt Flag Register1103
28.5.10	VDAC_IEN - Interrupt Enable Register1105
28.5.11	VDAC_CH0F - Channel 0 Data Write Fifo1106
28.5.12	VDAC_CH1F - Channel 1 Data Write Fifo1106
28.5.13	VDAC_OUTCTRL - DAC Output Control1107
28.5.14	VDAC_OUTTIMERCFG - DAC Out Timer Config Register1108
29.	ACMP - Analog Comparator1109
29.1	Introduction1109
29.2	Features1109
29.3	Functional Description1110
29.3.1	Configuration and Control1111
29.3.2	Warmup Time1111
29.3.3	Response Time1111
29.3.4	Hysteresis1112
29.3.5	Supply Voltage Monitoring (VSENSE)1112
29.3.6	VREFDIV Sources1112
29.3.7	Input Range and Accuracy Settings1112
29.3.8	Interrupts and PRS Output1113
29.3.9	Output to GPIO1113
29.4	ACMP Register Map1114
29.5	ACMP Register Description1115
29.5.1	ACMP_IPVERSION - IP Version ID1115
29.5.2	ACMP_EN - ACMP Enable1116
29.5.3	ACMP_SWRST - Software Reset1116
29.5.4	ACMP_CFG - Configuration Register1117
29.5.5	ACMP_CTRL - Control Register1118
29.5.6	ACMP_INPUTCTRL - Input Control Register1119
29.5.7	ACMP_STATUS - Status Register1124
29.5.8	ACMP_IF - Interrupt Flag Register1125
29.5.9	ACMP_IEN - Interrupt Enable Register1126
29.5.10	ACMP_SYNCBUSY - Syncbusy1126
30.	KEYSCAN - Keyboard Scan1127
30.1	Introduction.1127
30.2	Features1127
30.3	Functional Description1128
30.3.1	Row and Column Configuration1128
30.3.2	Clocking and Timing1128
30.3.3	Scanning1129

30.3.4	Wake on Key	1130
30.4	KEYSCAN Register Map	1131
30.5	KEYSCAN Register Description	1132
30.5.1	KEYSCAN_IPVERSION - IPVERSION	1132
30.5.2	KEYSCAN_EN - Enable	1132
30.5.3	KEYSCAN_SWRST - Software Reset	1133
30.5.4	KEYSCAN_CFG - Config	1134
30.5.5	KEYSCAN_CMD - Command	1135
30.5.6	KEYSCAN_DELAY - Delay	1136
30.5.7	KEYSCAN_STATUS - Status	1138
30.5.8	KEYSCAN_IF - Interrupt Flags	1139
30.5.9	KEYSCAN_IEN - Interrupt Enables	1140
31.	MVP - Matrix Vector Processor	1141
31.1	Introduction.	1141
31.2	Features	1142
31.3	Functional Description	1144
32.	Revision History.	1145
Appendix 1.	Abbreviations	1149

1. About This Document

1.1 Introduction

This document contains reference material for the EFR32xG24 devices. All modules and peripherals in the EFR32xG24 devices are described in general terms. Not all modules are present in all devices and the feature set for each device might vary. Such differences, including pinout, are covered in the device data sheets.



1.2 Conventions

Register Names

Register names are given with a module name prefix followed by the short register name:

TIMERn_CTRL - Control Register

The "n" denotes the module number for modules which can exist in more than one instance.

Some registers are grouped which leads to a group name following the module prefix:

GPIO_Px_DOUT - Port Data Out Register

The "x" denotes the different ports.

Bit Fields

Registers contain one or more bit fields which can be 1 to 32 bits wide. Bit fields wider than 1 bit are given with start (x) and stop (y) bit [y:x].

Bit fields containing more than one bit are unsigned integers unless otherwise is specified.

Unspecified bit field settings must not be used, as this may lead to unpredictable behaviour.

Address

The address for each register can be found by adding the base address of the module found in the Memory Map (see [Figure 4.1 System Address Space with Core and Code Space Listing on page 42](#)), and the offset address for the register (found in module Register Map).

Access Type

The register access types used in the register descriptions are explained in [Table 1.1 Register Access Types on page 28](#).

Table 1.1. Register Access Types

Access Type	Description
R	Read only. Writes are ignored
RW	Readable and writable
RW1	Readable and writable. Only writes to 1 have effect
W1	Read value undefined. Only writes to 1 have effect
W	Write only. Read value undefined.
RWH	Readable, writable, and updated by hardware
RW(nB), RWH(nB), etc.	"(nB)" suffix indicates that a bitfield explicitly does not support peripheral bit set/clear/toggle operations (see 4. Memory and Bus System)
RW(r), R(r), etc.	"(r)" suffix indicates that reading the register causes an action and may alter the register value.

Number format

0x prefix is used for hexadecimal numbers

0b prefix is used for binary numbers

Numbers without prefix are in decimal representation.

Reserved

Registers and bit fields marked with **reserved** are reserved for future use. These should be written to their reset value unless otherwise stated in the Register Description. Read values for reserved bits may be different in future or prior devices.

Reset Value

The reset value denotes the value after reset.

Registers denoted with X have unknown value out of reset and need to be initialized before use. Note that read-modify-write operations on these registers before they are initialized results in undefined register values.

Pin Connections

Pin connections are given with a module prefix followed by a short pin name:

CMU_CLKOUT1 (Clock management unit, clock output pin number 1)

The location for the pin names given in the module documentation can be found in the device-specific datasheet.

1.3 Related Documentation

Further documentation on the EFR32xG24 devices and the ARM Cortex®-M33 can be found at the Silicon Labs and ARM web pages:

www.silabs.com

www.arm.com

2. System Overview



Quick Facts

What?

The EFR32 Wireless Gecko is a highly integrated, configurable and low power wireless System-on-Chip (SoC) with a robust set of MCU and radio peripherals.

Why?

The Radio enables support for Bluetooth, Proprietary, and ZigBee protocols in 2.4 GHz frequency bands while the MCU system allows customized protocols and applications to run efficiently.

How?

Dynamic or fixed packet lengths, optional address recognition, and flexible CRC and security schemes makes the EFR32xG24 ideal for many wireless IoT applications. High performance analog and digital peripherals allow complete applications to run on the EFR32xG24 SoC.

2.1 Introduction

The high level features of EFR32xG24 include:

- High performance radio transceiver
 - Low power consumption in transmit, receive, and standby modes
 - Excellent receiver performance, including sensitivity, selectivity, and blocking
 - Excellent transmitter performance, including programmable output power, low phase noise, and power-amplifier (PA) ramping
- Configurable protocol support, including standards and customer-developed protocols
 - Preamble and frame synchronization insertion in transmit, and recovery in receive
 - Flexible CRC support, including configurable polynomial and multiple CRCs for single data frames
 - Basic address filtering performed in hardware
- High performance, low power MCU system
 - High Performance 32-bit ARM Cortex®-M33 CPU
 - Flexible and efficient energy management
 - Complete set of digital peripherals
 - Peripheral Reflex System (PRS)
 - Precision analog peripherals
- Low external component count
 - Fully integrated 2.4 GHz BALUN
 - Integrated tunable crystal loading capacitors
- Security
 - Secure Boot with Root of Trust and Secure Loader (RTSL)
 - Hardware Cryptographic Acceleration with DPA countermeasures for AES128/256, SHA-1, SHA-2 (up to 256-bit), ECC (up to 256-bit), ECDSA, ECDH and J-Pake
 - True Random Number Generator (TRNG) compliant with NIST SP800-90 and AIS-31
 - ARM® TrustZone®
 - Secure Debug with lock/unlock

A further introduction to the MCU and radio system is included in the following sections.

Note: Detailed performance numbers, current consumption, pinout etc. are available in the device datasheets.

2.2 Block Diagrams

The block diagram for the EFR32xG24 System-On-Chip series is shown in (Figure 2.1 EFR32xG24 System-On-Chip Block Diagram on page 32).

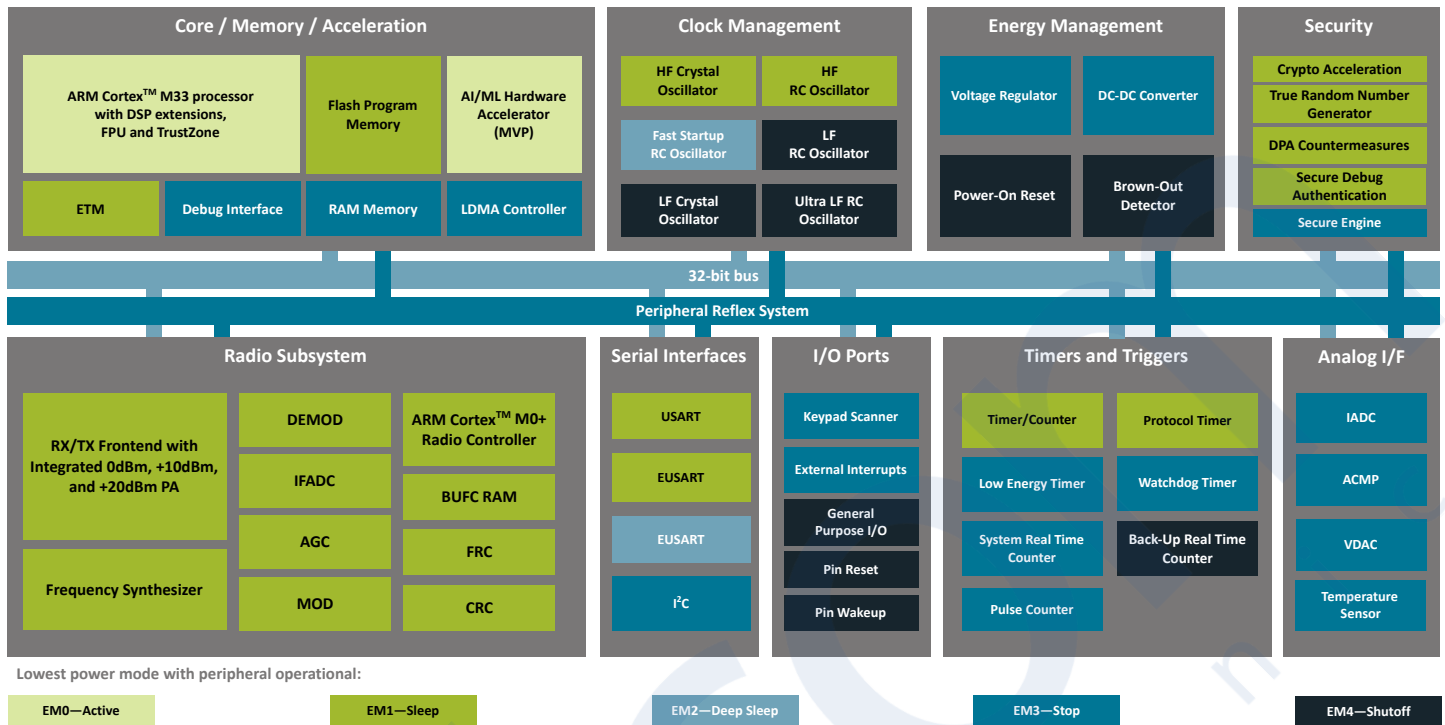

Figure 2.1. EFR32xG24 System-On-Chip Block Diagram

2.3 MCU Features overview

- **ARM Cortex®-M33 CPU platform**
 - High Performance 32-bit processor @ up to 78.0 MHz
 - DSP instruction support and floating-point unit
 - Memory Protection Unit
 - Wake-up Interrupt Controller
- **Flexible Energy Management System**
 - Five Energy Modes from EM0 to EM4 provide flexibility between higher performance and low power
 - Power routing configurations including DCDC control
 - Voltage Monitoring and Brown Out Detection
 - Automatic voltage scaling for additional energy savings
 - State Retention
- **Up to 1536 kB Flash**
- **Up to 256 kB RAM**
- **Up to 32 General Purpose I/O pins**
 - Configurable push-pull, open-drain, pull-up/down, input filter, slew rate
 - Configurable peripheral I/O locations
 - 16 asynchronous external interrupts
 - Output state retention and wake-up from Shutoff Mode
- **8 Channel DMA Controller**
 - Alternate/primary descriptors with scatter-gather/ping-pong operation
- **20 Channel Peripheral Reflex System (PRS)**
 - Autonomous inter-peripheral signaling enables smart operation in low energy modes
 - 16 asynchronous channels with configurable logic functionality
 - 4 synchronous channels for high-speed signalling between TIMER, IADC, and VDAC
- **General Purpose Cyclic Redundancy Check (GPCRC)**
 - Programmable 16-bit polynomial, fixed 32-bit polynomial
 - The GPCRC module is in addition to the radio CRC
- **Communication interfaces**
 - 1 × Universal Synchronous/Asynchronous Receiver/Transmitter (USART)
 - UART/SPI/SmartCard (ISO 7816)/IrDA/I2S
 - Triple buffered full/half-duplex operation
 - Hardware flow control
 - 4-16 data bits
 - 2 × Enhanced Universal Asynchronous Receiver/Transmitter (EUSART)
 - UART/SPI/IrDA/DALI support
 - High-speed operation in EM0/1 using high-frequency clock source
 - Low-energy operation in EM2 using 32.768 kHz clock source
 - Buffered full/half-duplex operation
 - Hardware flow control
 - 7/8/9 data bits
 - 2 × I²C Interface (I2C) with SMBus support
 - Address recognition in EM3 Stop Mode
- **Timers/Counters**
 - 2 × 32-bit and 3 × 16-bit Timer/Counters (TIMER)
 - 3 Compare/Capture/PWM channels
 - Dead-Time Insertion
 - 24-bit Low Energy Timer (LETIMER)
 - 32-bit Real-Time Capture Counter (SYSRTC)
 - 32-bit Ultra Low Energy Backup Real Time Counter (BURTC) for periodic wake-up from any Energy Mode
 - 2 × Watchdog Timer (WDOG)

- **Ultra low power precision analog peripherals**
 - Incremental Analog to Digital Converter (IADC) with 12-bit resolution at 1 Msps and 16-bit resolution at 76.9 kbps
 - Single ended or differential operation
 - Conversion tailgating for predictable latency
 - 2 × Analog Comparator (ACMP)
 - Programmable speed/current
 - 2 × 12-bit 500 kbps Digital to Analog Converter (VDAC)
 - 2 single ended channels/1 differential channel each
 - Analog Bus (ABUS) signal routing
 - Accurate die temperature sensor
 - External thermistor interface
- **Low-energy keypad scanner**
 - Up to 6 x 8 key switches supported
 - Autonomous keypad scanning in EM0 / EM1
 - Wake on key press from EM2 / EM3
- **Ultra efficient Power-on Reset (POR) and Brown-Out Detector (BOD)**
- **Debug Interface**
 - 4-pin Joint Test Action Group (JTAG) interface
 - 2-pin serial-wire debug (SWD) interface
- **Security**
 - Secure Boot with Root of Trust and Secure Loader (RTSL)
 - Prevents malware injection and rollback
 - Ensures authentic firmware execution and OTA updates
 - Dedicated Secure Core
 - Delivers faster, more energy efficient hardware crypto with Differential Power Analysis (DPA) countermeasures for AES128/256, SHA-1, SHA-2 (up to 256-bit), ECC (up to 256-bit), ECDSA, ECDH and J-Pake
 - Provides isolation with the application core
 - Provides hardware cryptographic acceleration
 - True Random Number Generator (TRNG) compliant with NIST SP800-90 and AIS-31
 - ARM® TrustZone®
 - Secure Debug with lock/unlock
 - Allows authenticated access for enhanced Failure Analysis (FA)

3. System Processor

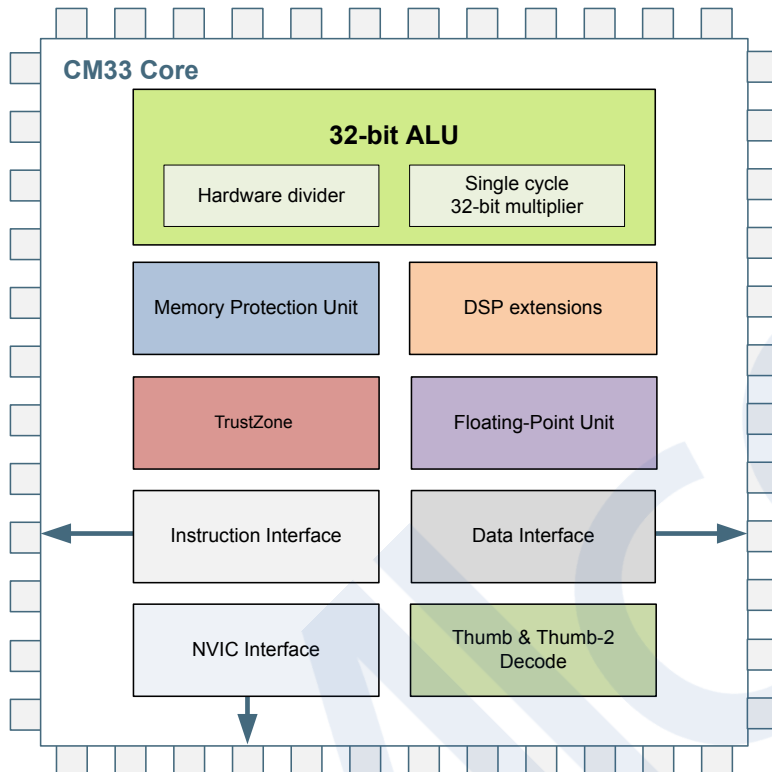
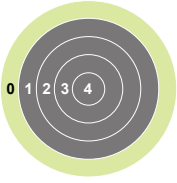

Quick Facts

What?

The EFR32xG24 features the industry leading Cortex®-M33 CPU from ARM.

Why?

The ARM Cortex®-M33 is designed for exceptionally short response time, high code density, and high 32-bit throughput while maintaining a strict cost and power consumption budget.

How?

Combined with the ultra low energy peripherals available in EFR32xG24 devices, the Cortex®-M33 processor's Harvard architecture, 3 stage pipeline, single cycle instructions, Thumb-2 instruction set support, and fast interrupt handling make it perfect for 8-bit, 16-bit, and 32-bit applications.

3.1 Introduction

The ARM Cortex®-M33 32-bit RISC processor provides outstanding computational performance and exceptional system response to interrupts while meeting low cost requirements and low power consumption.

The ARM Cortex®-M33 implemented is revision r0p4.

3.2 Features

- Harvard architecture
 - Separate data and program memory buses (No memory bottleneck as in a single bus system)
- 3-stage pipeline
- Thumb-2 instruction set
 - Enhanced levels of performance, energy efficiency, and code density
- Single cycle multiply and hardware divide instructions
 - 32-bit multiplication in a single cycle
 - Signed and unsigned divide operations between 2 and 11 cycles
- 1.5 DMIPS/MHz
- TrustZone
 - Independent Secure and Privileged states
 - Accelerated context switching
- 16 Region MPU
- 24-bit System Tick Timer for Real Time OS
- Excellent 32-bit migration choice for 8/16 bit architecture based designs
 - Simplified stack-based programmer's model is compatible with traditional ARM architecture and retains the programming simplicity of legacy 8-bit and 16-bit architectures
- Aligned or unaligned data storage and access
 - Contiguous storage of data requiring different byte lengths
 - Data access in a single core access cycle
- Integrated power modes
 - Sleep Now mode for immediate transfer to low power state
 - Sleep on Exit mode for entry into low power state after the servicing of an interrupt
 - Ability to extend power savings to other system components
- Optimized for low latency, nested interrupts

3.3 Functional Description

For a full functional description of the ARM Cortex®-M33 implementation in the EFR32xG24 family, the reader is referred to the ARM Cortex®-M33 documentation.

3.3.1 Interrupt Operation

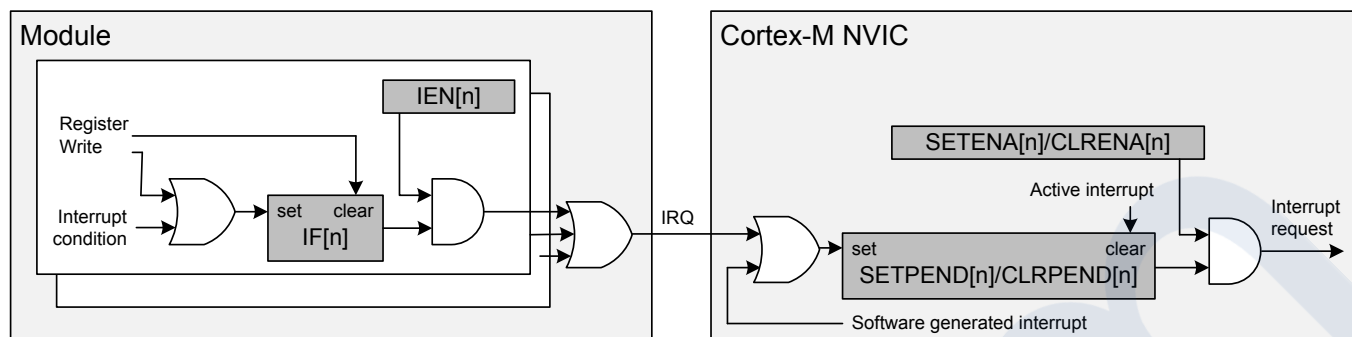

Figure 3.1. Interrupt Operation

The interrupt request (IRQ) lines are connected to the Cortex®-M33. Each of these lines (shown in [3.3.3 Interrupt Request Lines \(IRQ\)](#)) is connected to one or more interrupt flags in one or more modules. The interrupt flags are set by hardware on an interrupt condition. It is also possible to set/clear the interrupt flags through the IF register interface. When setting or clearing an interrupt through the IF register use of the IF_SET or IF_CLR bit operation registers is required; directly writing the main interrupt flag register will have no effect.

Each interrupt flag is then qualified with its own interrupt enable bit (IEN register), before being OR'ed with the other interrupt flags to generate the IRQ. A high IRQ line will set the corresponding pending bit (can also be set/cleared with the SETPEND/CLRPEND bits in ISPRn/ICPRn) in the Cortex®-M33 NVIC. The pending bit is then qualified with an enable bit (set/cleared with SETENA/CLRENA bits in ISERN/ICERN) before generating an interrupt request to the core. [Figure 3.1 Interrupt Operation on page 37](#) illustrates the interrupt system. For more information on how the interrupts are handled inside the Cortex®-M33, the reader is referred to the **ARM Cortex®-M33 Processor Technical Reference Manual**.

3.3.1.1 Avoiding Extraneous Interrupts

There can be latencies in the system such that clearing an interrupt flag could take longer than leaving an Interrupt Service Routine (ISR). This can lead to the ISR being re-entered as the interrupt flag has yet to clear immediately after leaving the ISR. To avoid this, when clearing an interrupt flag at the end of an ISR, the user should execute ARM's Data Synchronization Barrier (DSB) instruction. Another approach is to clear the interrupt flag immediately after identifying the interrupt source and then service the interrupt as shown in the pseudo-code below. The ISR typically is sufficiently long to more than cover the few cycles it may take to clear the interrupt status, and also allows the status to be checked for further interrupts before exiting the ISR.

```
irqXServiceRoutine() {
    do {
        clearIrqXStatus();
        serviceIrqX();
    } while(irqXStatusIsActive());
}
```

3.3.2 TrustZone

The Cortex®-M33 implements ARM TrustZone which provides the ability to restrict access to peripherals and memory regions based on the CPU security attribute. TrustZone works in combination with the MPU which controls privileged/unprivileged execution of code to provide a full security solution. The Security Management Unit (SMU) is used to configure access restrictions in the various modes. Refer to [10. SMU - Security Management Unit](#) for more information.

For information about TrustZone features in the core or information on TrustZone specific instructions please see the ARM Cortex®-M33 Processor Technical Reference Manual provided by ARM

3.3.3 Interrupt Request Lines (IRQ)

This table shows all IRQ's for the system processor. M33 High Speed interrupts are indicated by an '*'.

See the individual peripheral chapters for more information on interrupt function.

IRQ #	Name
0*	SMU_SECURE
1*	SMU_S_PRIVILEGED
2*	SMU_NS_PRIVILEGED
3*	EMU
4*	TIMER0
5*	TIMER1
6*	TIMER2
7*	TIMER3
8*	TIMER4
9*	USART0_RX
10*	USART0_TX
11*	EUSART0_RX
12*	EUSART0_TX
13*	EUSART1_RX
14*	EUSART1_TX
15*	MVP
16*	ICACHE0
17*	BURTC
18*	LETIMER0
19*	SYSCFG
20*	MPAHBRAM
21*	LDMA
22*	LFXO
23*	LFRCO
24*	ULFRCO
25*	GPIO_ODD
26*	GPIO_EVEN
27*	I2C0
28*	I2C1
29*	EMUDG
30*	AGC
31*	BUFC
32*	FRC_PRI
33*	FRC

IRQ #	Name
34*	MODEM
35*	PROTIMER
36*	RAC_RSM
37*	RAC_SEQ
38*	HOSTMAILBOX
39*	SYNTH
40*	ACMP0
41*	ACMP1
42*	WDOG0
43*	WDOG1
44*	HFX00
45*	HFRCO0
46*	HFRCOEM23
47*	CMU
48*	AES
49*	IADC
50*	MSC
51*	DPLL0
52*	EMUEFP
53*	DCDC
54*	PCNT0
55*	SW0
56*	SW1
57*	SW2
58*	SW3
59*	KERNEL0
60*	KERNEL1
61*	M33CTI0
62*	M33CTI1
63*	FPUEXH
64*	SETAMPERHOST
65*	SEMBRX
66*	SEMBTX
67*	SYSRTC_APP
68*	SYSRTC_SEQ
69*	KEYSCAN
70*	RFECA0

IRQ #	Name
71*	RFECA1
72*	VDAC0
73*	VDAC1
74*	AHB2AHB0
75*	AHB2AHB1



4. Memory and Bus System

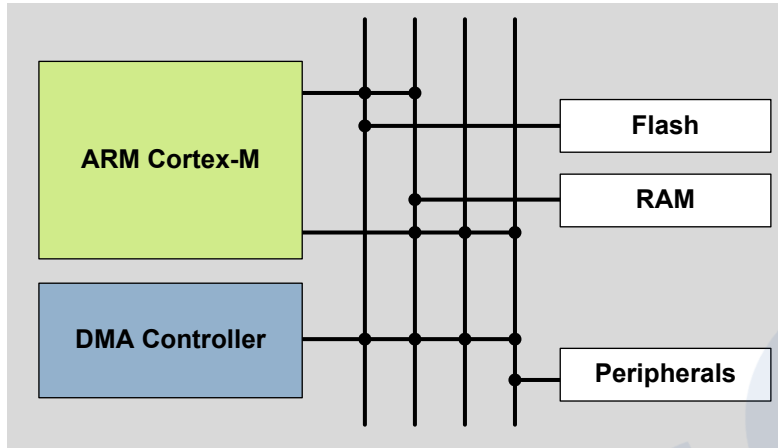
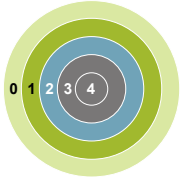

Quick Facts

What?

A low latency memory system including low energy Flash and RAM with data retention which makes the low energy modes attractive.

Why?

RAM retention reduces the need for storing data in Flash and enables frequent use of the ultra low energy modes EM2 and EM3.

How?

Low energy and non-volatile Flash memory stores program and application data in all energy modes and can easily be reprogrammed in system. Low leakage RAM with data retention in EM0 to EM3 removes the data restore time penalty, and the DMA ensures fast autonomous transfers with predictable response time.

4.1 Introduction

The EFR32xG24 contains a set of AMBA buses which move data between peripherals, memory, and the CPU. All memories and register interfaces are memory mapped into a unified address space.

4.2 Functional Description

The internal memory segments of the Cortex®-M33 are mapped into the system memory map as shown by [Figure 4.1 System Address Space with Core and Code Space Listing](#) on page 42.

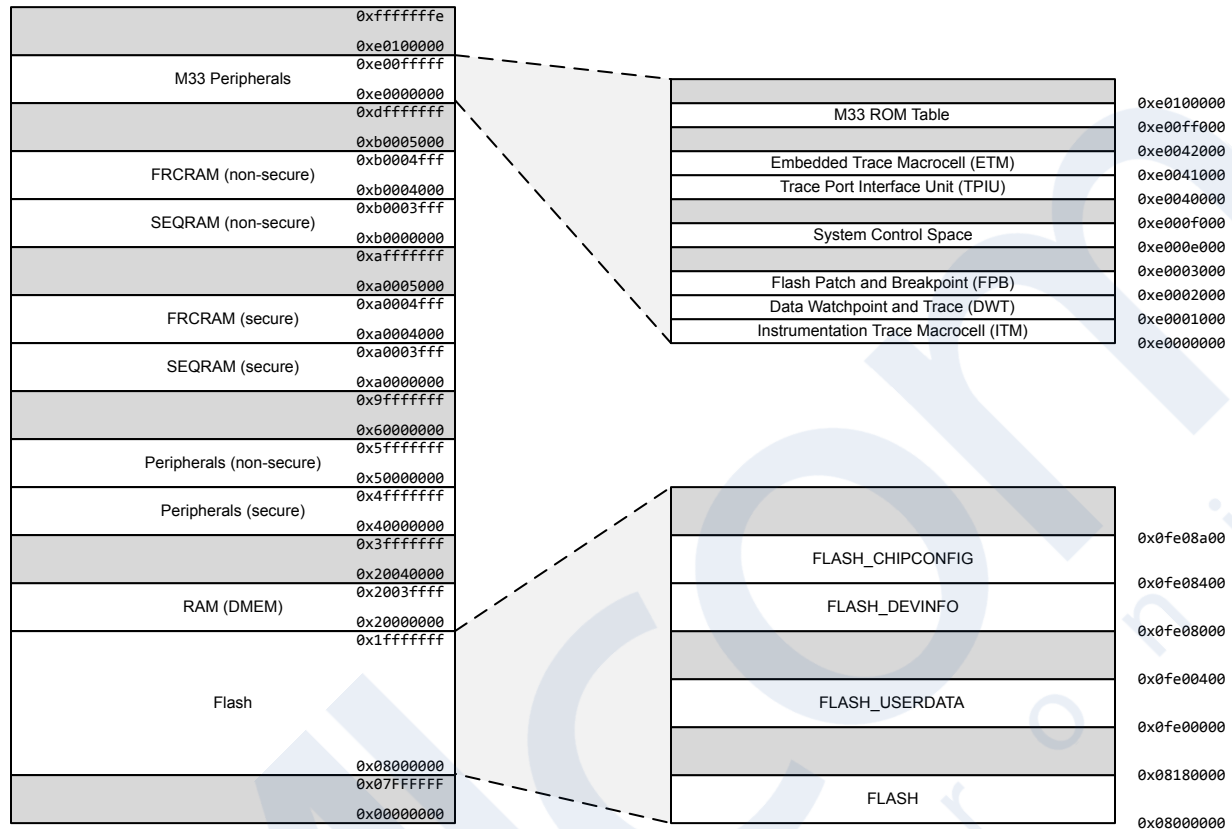

Figure 4.1. System Address Space with Core and Code Space Listing

Flash for the main program memory (CODE) is located at address 0x08000000 in the memory map of the EFR32xG24. Flash memory also contains a USERDATA area intended for user-defined data storage, the DEVINFO space with device characteristics and identifying information, and CHIPCONFIG with internal production test and calibration information.

SRAM for the main data memory (RAM) is located at address 0x20000000 in the memory map of the EFR32xG24. When running code located in RAM, the Cortex®-M33 uses the System bus interface to fetch instructions. This results in reduced performance as the Cortex®-M33 accesses stack, other data in SRAM and peripherals using the System bus interface.

The Sequencer RAM (SEQRAM) is located at address 0xA0000000 and is used by the Sequencer for both instructions and data. This RAM is also available for general use if not required by the RF subsystem.

4.2.1 Bus Matrix

A multilayer AMBA AHB bus matrix connects the manager bus interfaces to the AHB subordinates. The bus matrix allows several AHB subordinates to be accessed simultaneously. An AMBA APB interface is used for the peripherals, which are accessed through an AHB-to-APB bridge connected to the AHB bus matrix.

The CPU has two AHB bus managers (Code and System) so that it may retrieve instructions and data in parallel. The Code manager is used to access all memory below address 0x20000000 and the System manager access addresses 0x20000000 and above.

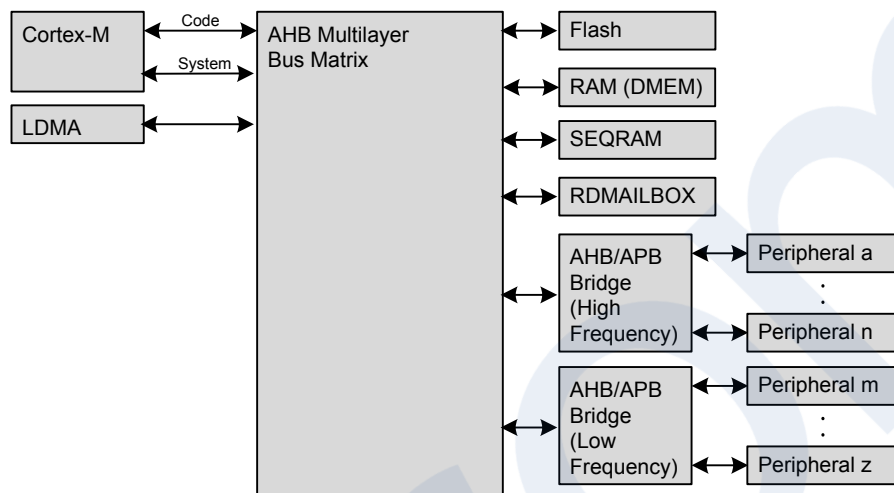

Figure 4.2. EFR32xG24 Bus System

4.2.1.1 Arbitration

The Bus Matrix uses a round-robin arbitration algorithm which enables high throughput and low latency, while starvation of simultaneous accesses to the same bus subordinate are eliminated. Round-robin does not assign a fixed priority to each bus manager. The arbiter does not insert any bus wait-states during peak interaction. However, one wait state is inserted for manager accesses occurring after a prolonged inactive time. This wait state allows for increased power efficiency during manager idle time.

4.2.1.2 Bus Faults

System accesses from the core can receive a bus fault in the following condition(s):

- The core attempts to access an address that is not assigned to any peripheral or other system device. These faults can be enabled or disabled by setting the ADDRFAULTEN bit in the SYSCFG_CTRL register.
- The core attempts to access a peripheral register that is LOCKED.
- The core attempts to access a peripheral or system device that has its clock disabled. This fault can be enabled or disabled by setting the ADDRFAULTEN bit in the SYSCFG_CTRL register.
- System RAM controller or RADIO RAM controller detects a 2 bit ECC error. These faults can be enabled or disabled by setting the RAMECCERRFAULTEN bit in the SYSCFG_CTRL register
- Registers with synchronization requirements may generate bus faults if accessed incorrectly. See [4.2.4.4 Peripheral Access Performance](#) for more details on register access types. In particular the following actions can cause bus faults:
 - Config register written while peripheral enabled.
 - Sync register written while peripheral disabled
 - LfSync register written while a previous write is pending
 - Peripheral disabled while any LfSync write is pending

In addition to any condition-specific bus fault control bits, the bus fault interrupt itself can be enabled or disabled in the same way as all other internal core interrupts.

4.2.2 Flash

The Flash retains data in any state and typically stores the application code and special user data. The Flash memory is typically programmed through the debug interface, but can also be erased and written to from software.

- Up to 1536 kB of memory
- Page size of 8 KB (minimum erase unit)
- Lock registers for memory protection
- Data retention in any state

4.2.3 SRAM

The primary task of the SRAM memory is to store application data. Additionally, it is possible to execute instructions from SRAM, and the DMA may be set up to transfer data between the SRAM, flash and peripherals.

The device contains several blocks of SRAM for various purposes including general data memory (DRAM) and various RF subsystem rams (SEQRAM, FRCRAM). For more detailed information see [6. MSC - Memory System Controller](#).

- Up to 256 kB of memory (RAM)
- RAM blocks may be powered down when not in use
- Data retention of the entire memory or selected banks in EM2 and EM3

Note: Root code requires some RAM storage during a system reset. The RAM used by root code is located at the top of the DRAM memory space. If the user application requires RAM that persists through reset, it is recommended to use a statically allocated section at the bottom of the SRAM memory space (address 0x20000000).

4.2.4 Peripherals

The peripherals are mapped into the peripheral memory segment, each with a fixed size address range shown in the [4.2.4.1 Peripheral Map](#)

4.2.4.1 Peripheral Map

This table shows the address range for each peripheral. In addition it shows the lowest energy mode in which the peripheral is powered. Note that EM3 is defined as EM2 with all clocks disabled. Therefore all peripherals powered in EM2 are also powered in EM3 but may not function if they require a running clock.

See the individual peripheral chapters for more information on low power operation.

Address Range	Module Name	Power Domain
0x40000000 - 0x40003FFF	SCRATCHPAD	EM1
0x40004000 - 0x40007FFF	EMU	EM2 (PD0A)
0x40008000 - 0x4000BFFF	CMU	EM2 (PD0B)
0x40010000 - 0x40013FFF	HFRCO0	EM1
0x40018000 - 0x4001BFFF	FSRCO	EM2 (PD0A)
0x4001C000 - 0x4001FFFF	DPLL0	EM1
0x40020000 - 0x40023FFF	LFXO	EM4
0x40024000 - 0x40027FFF	LFRCO	EM2 (PD0C) / EM4
0x40028000 - 0x4002BFFF	ULFRCO	EM4
0x40030000 - 0x40033FFF	MSC	EM1
0x40034000 - 0x40037FFF	ICACHE0	EM1
0x40038000 - 0x4003BFFF	PRS	EM2 (PD0E)
0x4003C000 - 0x4003FFFF	GPIO	EM2 (PD0B)
0x40040000 - 0x40043FFF	LDMA	EM1
0x40044000 - 0x40047FFF	LDMAXBAR	EM1
0x40048000 - 0x4004BFFF	TIMER0	EM1
0x4004C000 - 0x4004FFFF	TIMER1	EM1
0x40050000 - 0x40053FFF	TIMER2	EM1
0x40054000 - 0x40057FFF	TIMER3	EM1
0x40058000 - 0x4005BFFF	TIMER4	EM1
0x4005C000 - 0x4005FFFF	USART0	EM1
0x40064000 - 0x40067FFF	BURTC	EM4
0x40068000 - 0x4006BFFF	I2C1	EM1
0x40078000 - 0x4007BFFF	SYSCFG	EM1
0x4007C000 - 0x4007FFFF	SYSCFG	EM1
0x40080000 - 0x40083FFF	BURAM	EM4
0x40088000 - 0x4008BFFF	GPCRC	EM1
0x40094000 - 0x40097FFF	DCDC	EM2 (PD0B)
0x40098000 - 0x4009BFFF	HOSTMAILBOX	EM1
0x400A0000 - 0x400A3FFF	EUSART1	EM1
0x400A8000 - 0x400ABFFF	SYSRTC0	EM2 (PD0A)
0x400B0000 - 0x400B3FFF	KEYSCAN	EM2 (PD0E)
0x400B4000 - 0x400B7FFF	DMEM	EM1

Address Range	Module Name	Power Domain
0x44000000 - 0x440007FF	RADIOAES	EM1
0x44008000 - 0x4400BFFF	SMU	EM1
0x4400C000 - 0x4400FFFF	SMU	EM1
0x49000000 - 0x49003FFF	LETIMER0	EM2 (PD0B)
0x49004000 - 0x49007FFF	IADC0	EM2 (PD0B)
0x49008000 - 0x4900BFFF	ACMP0	EM2 (PD0B)
0x4900C000 - 0x4900FFFF	ACMP1	EM2 (PD0B)
0x49024000 - 0x49027FFF	VDAC0	EM2 (PD0B)
0x49028000 - 0x4902BFFF	VDAC1	EM2 (PD0B)
0x49030000 - 0x49033FFF	PCNT0	EM2 (PD0B)
0x4A000000 - 0x4A003FFF	HFRCOEM23	EM2 (PD0C)
0x4A004000 - 0x4A007FFF	HFXO0	EM2 (PD0C)
0x4B000000 - 0x4B003FFF	I2C0	EM2, (PD0D)
0x4B004000 - 0x4B007FFF	WDOG0	EM2, (PD0D)
0x4B008000 - 0x4B00BFFF	WDOG1	EM2, (PD0D)
0x4B010000 - 0x4B013FFF	EUSART0	EM2, (PD0D)
0x4C000000 - 0x4C00007F	SEMAILBOX	EM1
0x4D000000 - 0x4D003FFF	MVP	EM1
0x50000000 - 0x50003FFF	SCRATCHPAD_NS	EM1
0x50004000 - 0x50007FFF	EMU_NS	EM2 (PD0A)
0x50008000 - 0x5000BFFF	CMU_NS	EM2 (PD0B)
0x50010000 - 0x50013FFF	HFRCO0_NS	EM1
0x50018000 - 0x5001BFFF	FSRCO_NS	EM2 (PD0A)
0x5001C000 - 0x5001FFFF	DPLL0_NS	EM1
0x50020000 - 0x50023FFF	LFXO_NS	EM4
0x50024000 - 0x50027FFF	LFRCO_NS	EM2 (PD0C) / EM4
0x50028000 - 0x5002BFFF	ULFRCO_NS	EM4
0x50030000 - 0x50033FFF	MSC_NS	EM1
0x50034000 - 0x50037FFF	ICACHE0_NS	EM1
0x50038000 - 0x5003BFFF	PRS_NS	EM2 (PD0E)
0x5003C000 - 0x5003FFFF	GPIO_NS	EM2 (PD0B)
0x50040000 - 0x50043FFF	LDMA_NS	EM1
0x50044000 - 0x50047FFF	LDMAXBAR_NS	EM1
0x50048000 - 0x5004BFFF	TIMER0_NS	EM1
0x5004C000 - 0x5004FFFF	TIMER1_NS	EM1
0x50050000 - 0x50053FFF	TIMER2_NS	EM1
0x50054000 - 0x50057FFF	TIMER3_NS	EM1

Address Range	Module Name	Power Domain
0x50058000 - 0x5005BFFF	TIMER4_NS	EM1
0x5005C000 - 0x5005FFFF	USART0_NS	EM1
0x50064000 - 0x50067FFF	BURTC_NS	EM4
0x50068000 - 0x5006BFFF	I2C1_NS	EM1
0x50078000 - 0x5007BFFF	SYSCFG_NS	EM1
0x5007C000 - 0x5007FFFF	SYSCFG_NS	EM1
0x50080000 - 0x50083FFF	BURAM_NS	EM4
0x50088000 - 0x5008BFFF	GPCRC_NS	EM1
0x50094000 - 0x50097FFF	DCDC_NS	EM2 (PD0B)
0x50098000 - 0x5009BFFF	HOSTMAILBOX_NS	EM1
0x500A0000 - 0x500A3FFF	EUSART1_NS	EM1
0x500A8000 - 0x500ABFFF	SYSRTC0_NS	EM2 (PD0A)
0x500B0000 - 0x500B3FFF	KEYSCAN_NS	EM2 (PD0E)
0x500B4000 - 0x500B7FFF	DMEM_NS	EM1
0x54000000 - 0x540007FF	RADIOAES_NS	EM1
0x54008000 - 0x5400BFFF	SMU_NS	EM1
0x5400C000 - 0x5400FFFF	SMU_NS	EM1
0x59000000 - 0x59003FFF	LETIMER0_NS	EM2 (PD0B)
0x59004000 - 0x59007FFF	IADC0_NS	EM2 (PD0B)
0x59008000 - 0x5900BFFF	ACMP0_NS	EM2 (PD0B)
0x5900C000 - 0x5900FFFF	ACMP1_NS	EM2 (PD0B)
0x59024000 - 0x59027FFF	VDAC0_NS	EM2 (PD0B)
0x59028000 - 0x5902BFFF	VDAC1_NS	EM2 (PD0B)
0x59030000 - 0x59033FFF	PCNT0_NS	EM2 (PD0B)
0x5A000000 - 0x5A003FFF	HFRCOEM23_NS	EM2 (PD0C)
0x5A004000 - 0x5A007FFF	HFXO0_NS	EM2 (PD0C)
0x5B000000 - 0x5B003FFF	I2C0_NS	EM2, (PD0D)
0x5B004000 - 0x5B007FFF	WDOG0_NS	EM2, (PD0D)
0x5B008000 - 0x5B00BFFF	WDOG1_NS	EM2, (PD0D)
0x5B010000 - 0x5B013FFF	EUSART0_NS	EM2, (PD0D)
0x5C000000 - 0x5C00007F	SEMAILBOX_NS	EM1
0x5D000000 - 0x5D003FFF	MVP_NS	EM1

Note:

1. Peripherals listed as being in EM2 (PD0A) always remain powered in EM2 and EM3. Other EM2 power domains (PD0B, PD0C, etc.) are powered down in EM2 and EM3 if all peripherals on that domain are unused.
2. LFRCO requires EM0, EM1, or EM2 when operating in precision mode, but can operate down to EM4 when precision mode is not used.

4.2.4.2 Peripheral non-word access behavior

When writing to peripheral registers, all accesses are treated as 32-bit accesses. This means that writes to a register need to be large enough to cover all bits of register, otherwise, any uncovered bits may become corrupted from the partial-word transfer. Thus, the safest practice is to always do 32-bit writes to peripheral registers.

When reading, there is generally no issue with partial word accesses, however, note that any read action (e.g. FIFO popping) will be triggered regardless of whether the actual FIFO bit-field was included in the transfer size.

4.2.4.3 Peripheral Bit Set and Clear

The EFR32xG24 supports bit set, bit clear, and bit toggle access to most peripheral registers. The bit set and bit clear functionality (also called Bit Access) enables modification of bit fields without the need to perform a read-modify-write. Also, the operation is contained within a single bus access. Bit access registers and their addresses are shown in the register map for each peripheral. Peripherals with no `_SET`, `_CLR`, or `_TGL` registers in the register map do not support these functions.

Each register with Bit Set functionality will have a `_SET` register. Whenever a bit in the SET register is written to a 1 the corresponding bit in its target register is set. The SET register is located at `TARGET + 0x1000` where TARGET is the address of the target register and has the same name as the target register with `'_SET'` appended.

Each register with Bit Clear functionality will have a CLR register. Whenever a bit in the CLR register is written to a 1 the corresponding bit in its target register is cleared. The CLR register is located at `TARGET + 0x2000` where TARGET is the address of the target register and has the same name as the target register with `'_CLR'` appended.

Each register with Bit Toggle functionality will have a TGL register. Whenever a bit in the TGL register is written to a 1 the corresponding bit in its target register is inverted. The TGL register is located at `TARGET + 0x3000` where TARGET is the address of the target register and has the same name as the target register with `'_TGL'` appended.

Note: It is possible to combine bit clear and bit set operations in order to arbitrarily modify multi-bit register fields without affecting other fields in the same register. In this case, care should be taken to ensure that the field does not have intermediate values that can lead to erroneous behavior. For example, if bit clear and bit set operations are used to change an analog tuning register field from 0x2 to 0x4 by clearing bit 1 and then setting bit 2, the field would take on a value of zero for short time. If the analog module is active at the time, this could lead to undesired behavior.

4.2.4.4 Peripheral Access Performance

The Cortex®-M33, DMA Controller, and peripherals run on clocks which can be pre-scaled separately. Clocks and pre-scaling are described in more detail in [8. CMU - Clock Management Unit](#). This section describes the access performance for a peripheral register based on its frequency relative to the CPUCLK frequency and its access type. For this discussion, PERCLK refers to a selected peripheral's clock frequency and CPUCLK refers to the core's clock frequency.

The type of each register in a peripheral is indicated in the 'Access' column of the peripherals register table. Register types are: ENABLE, CONFIG, SYNC, LFSYNC, and INTFLAG. If not type is listed then the register is a Generic register.

4.2.4.4.1 Generic Registers

Registers with no type listed are generic registers. They may be read or written to at any time. Access will not stall the CPU.

4.2.4.4.2 CONFIG Registers

CONFIG Registers contain configuration that does not change during peripheral operation.

CONFIG registers may only be written when a peripheral is disabled. Writing to a CONFIG register when a peripheral is enabled will result in a BUSFAULT. CONFIG register writes will not stall the CPU.

CONFIG registers may be read at any time. Reads will not stall the CPU.

4.2.4.4.3 SYNC Registers

SYNC registers are used to communicate with running high-speed peripherals where PERCLK is expected to be either higher or marginally slower (within an order of magnitude) than CPUCLK. For example a timer running at 76.8 MHz when the core is at 38.4 MHz or at 9.6 MHz when the core is 76.8 MHz. In this case CPU stalls of several PERCLK cycles do not significantly impact overall system performance in most systems.

SYNC registers may only be written to when the peripheral is enabled. Writing to a SYNC register when a peripheral is disabled will result in a BUSFAULT. A write will take several (2 - 3) PERCLK cycles to complete (take effect) during which time the entire module will be in a pending state. If a SYNC register is written to while the peripheral is already in a pending state, the CPU is stalled until the previous write finishes. If a SYNC register is written to while the peripheral is not in a pending state, the CPU is not stalled.

SYNC registers may be read at any time. If a SYNC register is read while the peripheral is disabled, the CPU is not stalled. If a SYNC register is read while the peripheral is enabled, the CPU will be stalled for several (2 - 3) PERCLK cycles while up to date values are retrieved from the peripheral.

4.2.4.4.4 LFSYNC Registers

LFSYNC registers are used to communicate with running low frequency peripherals where PERCLK is expected to be much lower than the CPU clock and synchronization delays may be long. For example, a LETIMER running at 32 kHz when the core is at 76.8 MHz. In this case CPU stalls of several PERCLK cycles represent a significant blockage of the CPU and need to be avoided whenever possible. LFSYNC registers accommodate this by allowing the CPU to write the register and continue to do other work while the value is synchronized.

LFSYNC registers may be written at any time. A write will take several (3 - 4) PERCLK cycles to complete during which the register will be in a pending state. If a LFSYNC register is written to while it is in a pending state, a BUSFAULT will occur. Each LFSYNC register has a status bit indicating if it is currently pending.

LFSYNC registers may be read at any time. The CPU is never stalled on a read. If a LFSYNC register is read while pending, the pending (recently written) data will be returned even though it has not yet taken effect. Software may use the busy status bit to determine if the read value has been applied to the hardware.

4.2.4.4.5 ENABLE Registers

ENABLE registers contain the enable bit for a peripheral.

ENABLE registers may be written at any time. When the peripheral is enabled it takes some time for the enable to take effect during which time the module is pending. Peripherals will be in the pending state for a few (2 - 3) PERCLK cycles when first enabled. Since the clock source for the peripheral may not be running before the peripheral is enabled, the start up time for the clock source may increase the pending time. See [EFR32xG24 Wireless SoC](#) for more information on on-demand clock sources.

Disabling a high frequency module will stall the CPU until all pending SYNC writes have completed and any pending enable has completed. If the module is fully enabled and no SYNC writes are pending, the disable will be instantaneous. Disabling low frequency peripheral which a LFSYNC is pending will result in a bus fault. Disabling a low frequency peripherals while an enable is still pending causes no CPU stall.

ENABLE registers may be read at any time.

4.2.4.4.6 INTFLAG Registers

INTFLAG registers contain interrupt flags. To set or clear an interrupt flag, the `_SET` or `_CLR` register alias must be used. Writing directly to the INTFLAG register will have no effect.

Note that for an interrupt to occur when a flag is set the IRQ must be enabled in the NVIC.

5. Radio Transceiver

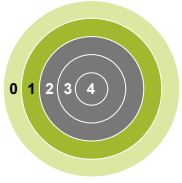

Quick Facts

What?

The Radio Transceiver provides access to transmit and receive data, radio settings and control interface.

Why?

The Radio Transceiver enables the user to communicate using a wide range of data rates, modulation and frame formats.

How?

Dynamic or fixed frame lengths, optional address recognition, flexible CRC and crypto schemes makes the EFR32 Series 2 perfectly suit any application using low or medium data rate radio communication.

5.1 Introduction

The Radio Transceiver of the EFR32 Series 2 enables the user to control a wide range of settings and options for tailoring radio operation precisely to the users need. It provides access to the transmit and receive data buffers and supports both dynamic and static frame lengths, as well as automatic address filtering and CRC insertion/verification.

As seen in the Radio Overview illustration (Figure 5.1 Radio Overview on page 51), the radio consists of several modules all responsible for specific tasks. Please refer to the abbreviations section (Appendix 1. Abbreviations) for a comprehensive description of acronyms.

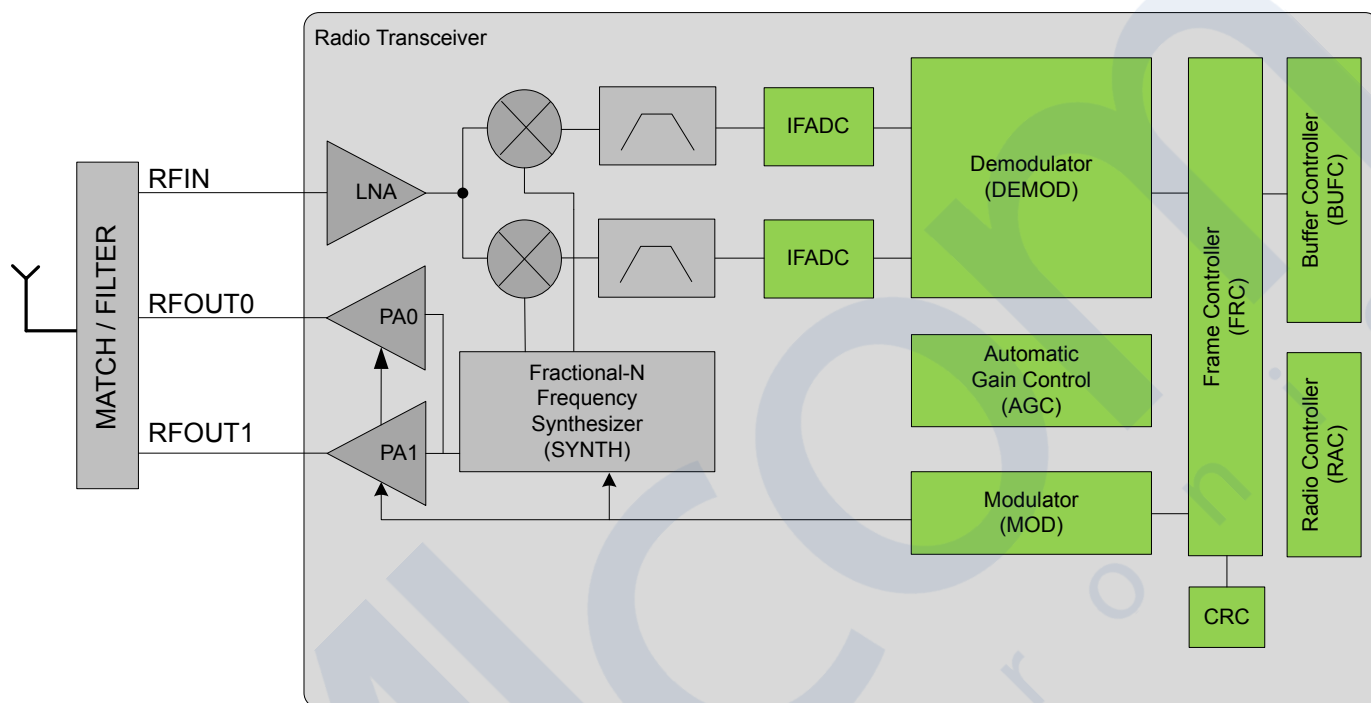

Figure 5.1. Radio Overview

During transmission (TX), the Radio Controller enables the Frequency Synthesizer (SYNTH), Modulator (MOD), and Power Amplifier (PA). The Modulator requests data from the Frame Controller (FRC), which reads data from a buffer. Based upon modulation format and data to send, the Modulator manipulates the SYNTH to output the correct frequency and phase. When the whole frame has been transmitted, the radio can automatically switch to receive mode.

In receive mode (RX), the radio controller enables the Low Noise Amplifier (LNA), Frequency Synthesizer (SYNTH), Mixers, Intermediate Frequency ADCs (IFADC), and Demodulator (DEMOD). The Demodulator searches for valid frames according to modulation format and data rate. If a frame is detected, the demodulated data is handed to the Frame Controller (FRC), which stores the data in the Buffer. When the complete frame has been received (determined by the Frame Controller), it is possible to either go to TX or stay in RX to search for a new frame.

The Radio Transceiver interface is accessible through software drivers provided by Silicon Labs.

5.1.1 RF Frequency Synthesizer

The Fractional-N RF Frequency Synthesizer (SYNTH) provides a low phase noise LO signal to be used in both receive and transmit modes.

The capabilities of the SYNTH include:

- High performance, low phase noise
- Fast frequency settling
- Fast and fully automated calibration
- Sub 100 Hz frequency resolution across the supported frequency bands

5.1.2 Modulation Modes

EFR32xG24 supports a wide range of modulation modes in transmit and receive:

- 2-FSK, 2-GFSK, 4-FSK, MSK, GMSK, O-QPSK with half-sine shaping, ASK / OOK, DBPSK TX
- NRZ or Manchester support
- UART mode over air for legacy protocols
- Baudrates ranging from below 100 Baud/s to 2 MBaud/s, allowing data rates up to 4 MBit/s
- Configurable frequency deviation
- Configurable Direct Sequence Spread Spectrum (DSSS), with spread sequences up to 32 chips encoding up to 4 information bits
- Configurable 4-FSK symbol encoding

5.1.3 Transmit Mode

In transmit mode EFR32xG24 performs the following functionality:

- Automatic PA power ramping during the start and end of a frame transmit
- Programmable output power
- Optional preamble and synchronization word insertion
- Accurate transmit frame timing to support time synchronized radio protocols
- Optional Carrier Sense Multiple Access - Collision Avoidance (CSMA-CA) or Listen Before Talk (LBT) hardware support
- Integrated transmit test modes, as described in [5.1.12 RF Test Modes](#)

5.1.4 Receive Mode

In receive mode EFR32xG24 performs the following functionality:

- A single-ended LNA amplifies the input RF signal. The amplified signal is then mixed to a low-IF signal through the quadrature down-conversion mixer. Further signal filtering is performed before conversion to a digital signal through the I/Q ADC.
- Digitally configurable receiver bandwidth from 100 Hz to 2.5 MHz
- Timing recovery on received data, including simultaneous support for two different frame synchronization words
- Automatic frequency offset compensation, to compensate for carrier frequency offset between the transmitter and receiver
- Support for a wide range of modulation formats as described in section [5.1.2 Modulation Modes](#)

5.1.5 Data Buffering

EFR32xG24 supports buffered transmit and receive modes through its buffer controller (BUFC), with four individually configurable buffers. The BUFC uses the system RAM as storage, and each buffer can be individually configured with parameters such as:

- Buffer size
- Buffer interrupt thresholds
- Buffer RAM location
- Overflow and underflow detection

In receive mode, data following frame synchronization is moved directly from the demodulator to the buffer storage.

In transmit mode, data following the inserted preamble and synchronization word is moved directly from the buffer storage to the modulator.

5.1.6 Unbuffered Data Transfer

For most system designs it is recommended to use the data buffering within EFR32xG24 to provide a convenient user interface.

In unbuffered data transfer modes the hardware support provided by EFR32xG24 to perform preamble and frame synchronization insertion in transmit mode and detection in receive mode can still optionally be used.

5.1.7 Frame Format Support

EFR32xG24 has an extensive support for frame handling in transmit and receive modes, which allows effective handling of even advanced protocols. The frame format support is controlled by the Frame Controller (FRC). The support includes:

- Preamble and frame synchronization inserted into transmitted frames
- Full frame synchronization of received frames
- Simple address matching of received frames in hardware, further configurable address and frame filtering supported through sequencer
- Support for variable length frames
- Automated CRC calculation and verification
- Configurable bit ordering, with the most or least significant bit transmitted and received first

5.1.8 Hardware CRC Support

EFR32xG24 supports a configurable CRC generation in transmit and verification in receive mode:

- 8, 16, 24 or 32 bit CRC value
- Configurable polynomial and initialization value
- Optional inversion of CRC value over air
- Configurable CRC byte ordering
- Support for multiple CRC values calculated and verified per transmitted or received frame
- The CRC module is typically controlled by the Frame Controller (FRC) for in-line operations in transmit and receive modes. Alternatively, the CRC module may be accessed directly from software to calculate and verify CRC data.

5.1.9 Convolutional Encoding / Decoding

EFR32xG24 includes hardware support for convolutional encoding and decoding, for forward error correction (FEC). This feature is performed by the Frame Controller (FRC) module:

- Constraint length configurable up to 7, for the highest robustness
- Configurable puncturing, to achieve rates between 1/2 rate and full rate
- Configurable soft decision or hard decision decoding
- Convolutional coding may be used together with the symbol interleaver to improve robustness against burst errors

5.1.10 Binary Block Encoding / Decoding

EFR32xG24 includes hardware support for binary block encoding and decoding, both performed real-time in the the transmit and receive path. This is performed in the Frame Controller (FRC) module:

The block coding works on blocks of up to 16 bits of data and adds parity bits to be capable of single or multiple bit corrections by the receiver.

- One or more parity bits can be added and verified
- Bit error correction
- Lookup-codes can be used to implement virtually any block coding scheme

5.1.11 Data Encryption and Authentication

EFR32xG24 has hardware support for AES encryption, decryption and authentication modes. These security operations can be performed on data in RAM or any data buffer, without further CPU intervention. The key size is 128 bits.

AES modes of operations directly supported by the EFR32xG24 hardware are listed in [Table 5.1 AES modes of operation with hardware support on page 54](#). In addition to these modes, other modes can also be implemented by using combinations of modes. For example, the CCM mode can be implemented using the CTR and CBC-MAC modes in combination.

Table 5.1. AES modes of operation with hardware support

AES Mode	Encryption / Decryption	Authentication	Comment
ECB	Yes	-	Electronic Code Book
CTR	Yes	-	Counter mode
CCM	Yes	Yes	Counter with CBC-MAC
CCM*	Yes	Yes	CCM with encryption-only and integrity-only capabilities
GCM	Yes	Yes	Galois Counter Mode
CBC	Yes	-	Cipher Block Chaining
CBC-MAC	-	Yes	Cipher Block Chaining, Message Authentication Code
CMAC	-	Yes	Cipher-based MAC
CFB	Yes	-	Cipher Feedback
OFB	Yes	-	Output Feedback

The Cryptographic Acceleration module can operate directly on data buffers provided by the buffer controller (BUFC) module. It is also possible to provide data directly from the embedded Cortex®-M33 or via DMA.

5.1.12 RF Test Modes

EFR32xG24 supports a wide range of RF test modes typically used for characterization and regulation compliance testing, including:

- Unmodulated carrier transmit
- Modulated carrier transmit, with internal configurable pseudo random data generator
- Continuous data reception for Bit Error Rate (BER) measurements
- Storing of raw receiver data to RAM
- Transmit of raw frequency data from RAM

6. MSC - Memory System Controller

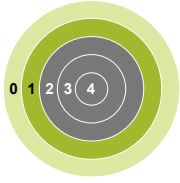

```

01000101011011100110010101110010
01100111011110010010000001001101
01101001011000110111001001101111
00100000011100100111010101101100
01100101011100110010000001110100
01101000011001010010000001110111
01101111011100100110110001100100
00100000011011110110011000100000
01101100011011110111011100101101
01100101011011100110010101110010
01100111011110010010000001101101
01101001011000110111001001101111
01100011011011110110111001110100
01110010011011110110110001101100
01100101011100100010000001100100
01100101011100110110100101100111
01101110001000010100010101101110

```

Quick Facts

What?

The user can perform flash memory read, read configuration, and write operations through the Memory System Controller (MSC). SRAM operation may be configured through System Configuration (SYSCFG).

Why?

The MSC allows the application code and user data to be stored in non-volatile flash memory. Certain memory system functions, such as program memory wait-states and flash lock bits are configured from the MSC peripheral register interface, giving the developer the ability to dynamically customize the memory system performance, security level, energy consumption and error handling capabilities to the requirements at hand.

How?

The MSC integrates a low-energy flash IP with a charge pump, enabling minimum energy consumption while eliminating the need for external programming voltage to erase the memory. An easy to use write and erase interface is supported by an internal, fixed-frequency oscillator and autonomous flash timing and control reduces software complexity while not using other timer resources.

A highly efficient low energy instruction cache reduces the number of flash reads significantly, thus saving energy. Performance is also improved when wait-states are used, since many of the wait-states are eliminated. Built-in performance counters can be used to measure the efficiency of the instruction cache.

Instruction prefetcher improves program execution performance by reducing the number of wait-state cycles needed.

6.1 Introduction

The Memory System Controller (MSC) is the program memory unit of the EFR32xG24 microcontroller. The flash memory is readable and writable from both the Cortex®-M33 and DMA. The flash memory is divided into two blocks: the main block and the information block. Program code is normally written to the main block. The information block is available for special user data. There is also a read-only page in the information block containing system and device calibration data. Flash read and write operations are supported in energy modes EM0 and EM1.

6.2 Features

- AHB read interface
 - Scalable access performance to optimize the Cortex®-M33 code interface
 - Advanced energy optimization functionality
 - Conditional branch target prefetch suppression
 - Cortex®-M33 unfolding of if-then (IT) blocks
 - Instruction Cache
 - Instruction Prefetch
 - DMA read support in EM0 and EM1
- Command and status interface
 - Flash write and erase
 - Accessible from Cortex®-M33 in EM0
 - DMA write support in EM0 and EM1
 - Core clock independent flash timing
 - Internal oscillator and internal timers for precise and autonomous flash timing
 - General purpose timers are not occupied during flash erase and write operations
 - No special time scaling registers needed
 - Configurable interrupt erase abort
 - Improved interrupt predictability
 - Memory and bus fault control
- Security features
 - Lockable debug access
 - Page lock registers
 - SW Mass erase and User Data lock bits
- End-of-write and end-of-erase interrupts

6.3 Functional Description

The size of the main flash block is device dependent. The largest size available is 1536 kB (192 pages). The information block has 1 kB available for user data. The information block also contains chip configuration data located in a reserved area. The main block is mapped to address 0x08000000 and the information block is mapped to address 0x0FE00000. [Table 6.1 MSC Flash Memory Mapping on page 56](#) outlines how the flash is mapped in the memory space. All flash memory is organized into 8 kB pages.

Table 6.1. MSC Flash Memory Mapping

Block	Page	Base address	Write/Erase by...	Software Readable?	Purpose/Name	Size
Main	0	0x08000000	Software, debug	Yes	User code and data	16 kB - 1536 kB
	1	0x08002000	Software, debug	Yes		
	...		Software, debug	Yes		
	191 ¹	0x0817E000	Software, debug	Yes		
Information	N/A	0x0FE00000	Software, debug	Yes	User Data (UD)	1 kB
	N/A	0x0FE08000	-	Yes	Device Information (DI)	1 kB

Note:

1. 192 pages for largest device.

6.3.1 RAM Configuration

The SYSCFG and MPAHB RAM modules contain controls for configuring the various RAM blocks on the device. Options include enabling EM2/EM3 data retention, ECC, and RAM port priorities. For a complete description see [6.6 SYSCFG - System Configuration](#).

6.3.2 Instruction Cache

The instruction cache improves the speed and power consumption of the Cortex®-M33 by providing fast, low-power access to recently executed instructions. For detailed information see [6.5 ICACHE - Instruction Cache](#)

6.3.3 Device Information (DI) Page

This read-only page holds calibration data from the production test, several unique device IDs, and other part specific information. For a complete description see [6.4 DEVINFO - Device Info Page](#).

6.3.4 User Data (UD) Page Description

This is the user data page in the information block. The page can be erased and written by software when MISCLOCKWORD.UDLOCKBIT is 0.

6.3.5 Bootloader

The EFR32xG24 supports use of the Gecko Bootloader detailed in *UG489: Silicon Labs Gecko Bootloader User's Guide for GSDK 4.0 and Higher* (<https://www.silabs.com/support/resources>). To enable bootloader functionality, the second stage of the bootloader must be configured and programmed into the beginning of flash. The first stage of the bootloader is provided by the SE and is not user accessible. For more details on SE bootloader support, see the SE peripheral documentation.

6.3.6 Post-reset Behavior

Calibration values are automatically written to registers by the MSC before application code start-up. The values can also be read from the DI page by software. Other information such as the device ID and production date is also stored in the DI page and is readable from software.

As part of the reset, hardware performs repeated flash reads to determine when flash is fully powered up and available for use by the CPU. PWRUPCKBDFAILCOUNT in MSC_STATUS contains the number of failed reads during the last reset.

6.3.7 Flash Startup

Flash wakeup on demand is supported when waking from EM2/3 to EM0. Set bit FLASHPWRUPONDEMAND of register EMU_CTRL to enable the power up on demand. When enabled, flash will not be powered up until accessed. In this case it is possible for the MCU to wake, execute out of RAM or cache, and return to sleep mode without ever powering on the flash. Software can force the flash to power up by writing PWRUP in MSC_CMD. When flash is powered via MSC_CMD the MSC_IF.PWRUPF interrupt flag will be set when power up is complete and the CPU will be interrupted if MSC_IEN.PWRUPF is set.

6.3.8 Flash EM0 / EM1 Power Down

It is also possible to put the flash in a power-saving sleep mode when the system is in EM0 or EM1. Flash power down can be configured to happen on entering EM1, radio-only sleep, or with an immediate manual operation.

During EM0, software can instruct the flash to go to power down mode with the MSC_CMD.PWROFF command. Any system IRQ or flash read will wake the flash. The MSC_CMD.PWRUP command is used to power the flash back up in the absence of a wake event.

The MSC_PWRCTRL register allows the flash to be configured to automatically enter sleep mode on entering EM1 or radio-only sleep with the bits PWROFFONEM1ENTRY and PWROFFONEM1PENTRY, respectively. If the flash is configured to sleep during one of these states, it may sometimes be powered back up without processor intervention in EM0 (for example, if DMA reads flash in EM1). By default, the flash will remain powered on after such access. If the PWROFFENTRYAGAIN bit is set, it instructs the flash to re-enter the power down state if no further access is seen during the timeout period defined by PWROFFDLY. Flash must be idle for PWROFFDLY * 64 bus clocks before it will enter sleep again.

6.3.9 Wait-states

Since the CPU may be clocked faster than the flash can respond, it is necessary to configure wait-states for flash accesses at higher CPU clock speeds. See the device Datasheet for information on the maximum allowed frequency for each wait-state setting. To configure the flash wait-states set the MODE field in MSC_READCTRL.

When changing wait states, care should be taken that the system is never in an invalid state. To ensure this, MODE should be changed after the clock is changed when reducing clock speed and before the clock is changed when increasing clock speed.

6.3.10 Cortex®-M33 If-Then Block Folding

The Cortex®-M33 offers a mechanism known as if-then block folding. This is a form of speculative prefetching where small if-then blocks are collapsed in the prefetch buffer if the condition evaluates to false. The instructions in the block then appear to execute in zero cycles. With this scheme, performance is optimized at the cost of higher energy consumption as the processor fetches more instructions from memory than it actually executes. To disable the mode, write a 1 to the DISFOLD bit in the NVIC Auxiliary Control Register; see the Cortex®-M33 Technical Reference Manual for details. Normally, it is expected that this feature is most efficient when operating with 0 wait-states. Folding is enabled by default.

6.3.11 Line Buffering (Prefetch)

The MSC reads a 2-word line from flash on any flash access. The data being accessed is returned immediately and the other word locally cached so that it can be provided immediately if accessed. This has the effect of pre-fetching the second word when the first is read, resulting in fewer wait-states when executing sequential code. This feature may be disabled by setting DOUTBUFEN in MSC_READCTRL.

6.3.12 Erase and Write Operations

To erase a page first set WREN in MSC_WRITECTRL and load any address in the page to be erased into the MSC_ADDRB register. Next check INVADDR, LOCKED, and WREADY in MSC_STATUS to ensure that the address is valid, not locked, and the MSC is ready to modify flash. Writing ERASEPAGE in MSC_WRITEMD will execute the page erase operation. ERASE in MSC_IF will be set when the page erase is complete. If ERASE in MSC_IEN is set, the end of a page erase will also trigger an interrupt. Finally, clear WREN to disable flash operations.

In addition to a page erase, a mass erase will clear the entire contents of the main flash array. A mass erase can be initiated by the Secure Engine. User Data page contents are not included in a mass erase.

To perform a programming operation, set WREN and load the address to be programmed into the MSC_ADDRB register. Next check INVADDR, LOCKED, WREADY, and WDATAREADY in MSC_STATUS to ensure that the address is valid, not locked, the MSC is ready to modify flash, and the write data buffer is clear. Writing data to MSC_WDATA will begin the programming operation. If a burst write is being performed, the next data word can be programmed to MSC_WDATA as soon as WDATAREADY is set. WRITE in MSC_IF will be set when the programming operation is complete. If WRITE in MSC_IEN is set, the end of the program operation will also trigger an interrupt. Finally, clear WREN to disable flash operations.

If data is written to the MSC_WDATA register faster than it can be processed, WDATAOV in MSC_IF will be set. If WDATAOV in MSC_IEN is set an interrupt will also be fired.

The MSC_ADDRB register only has to be written once when writing to sequential words. After each word is written, ADDRb is incremented automatically by 4. The INVADDR bit of the MSC_STATUS register is set if the loaded address is outside the flash. The LOCKED bit of the MSC_STATUS register is set if the page addressed is locked. Any attempts to erase or write to the page are ignored if INVADDR or the LOCKED bits of the MSC_STATUS register are set.

Write and erase operations may be aborted by software. To abort an erase, set the ERASEABORT bit in the MSC_WRITECMD register. To abort a write, set WRITEEND in MSC_WRITECMD.

For a DMA write, CLEARWDATA in MSC_WRITECMD to assert a DMA request and transfer the first word. Alternately the first word may be programmed manually into MSC_WDATA by code.

By default, if any interrupt occurs during an erase operation, the erase is aborted. This feature may be disabled by clearing IRQERASEABORT in MSC_WRITECTRL. When an erase is aborted due to an interrupt, ERASEABORTED in MSC_STAUTS is set by hardware.

Software may observe the status of the MSC via the MSC_STATUS register. When a flash operation is in progress, BUSY will be set. If a flash operation has been requested but not yet started, PENDING will be set. This may occur if a subsystem is performing MSC operations. When the write buffer underflows, TIMEOUT will be set. Buffer underflow is a normal part of the write procedure since it will occur once the last word has been written and no more data is available.

The flash memory is organized into 64-bit wide double-words. Each 64-bit double-word can be written only twice between erase cycles. The lower and upper 32-bit words may be written sequentially in any order, or one at a time. Each flash bit is 1 after erase. Writing a 0 will clear the bit. Writing a 1 will not change the bit value.

While it is possible to write twice to the lower or upper 32-bit word of the 64-bit double word, then the other 32-bit word cannot be used. In this case, it is permitted to write to either the lower or upper 32-bit word twice between each erase, so long as no bit is ever cleared more than once.

Note: The ERASEPAGE bit in WRITECMD and the WDATA register cannot safely be written from code in flash. It is recommended to place a small code section in RAM to set these bits and wait for the operation to complete. Also note that DMA transfers to or from any other address in flash while a write or erase operation is in progress will produce unpredictable results.

Note: During a write or erase, flash read accesses will be stalled, effectively halting code execution from flash. Code execution continues upon write/erase completion. Code residing in RAM or ICACHE may be executed during a write/erase operation.

6.3.12.1 Low-Power Write

To limit maximum current, the programming operations can be slowed down. Set LPWRITE in MSC_WRITECTRL to double the write time and halve the write current.

6.3.12.2 Flash Lock

The ability to program or erase individual flash pages may be disabled using the MSC_PAGELOCKn registers. The bits in these registers may only be set to 1 by software on the device and are cleared when the device is reset. This means that once locked, a page may not be unlocked until a reset occurs. Users wishing to lock accesses to flash should implement code to write to the MSC_PAGELOCKn registers immediately after a reset. Any page locked in this way cannot be written to or erased.

User Data can be locked by setting MSC_MISLOCKWORD.UDLOCK to 1. Mass erase is enabled out of reset, however if firmware sets MELOCKBIT in the MSC_MISLOCKWORD register, then mass erase can only be issued by the SE.

6.4 DEVINFO - Device Info Page

The Device Info Page holds factory programmed information about the device. It contains the following data:

- Calibration values for reconfiguring the device
- Unique ID's
- OPN identifiers (family, feature set, flash size, etc.)

6.4.1 DEVINFO Register Map

The offset register address is relative to the registers base address.

Offset	Name	Type	Description
0x000	DEVINFO_INFO	R	DI Information
0x004	DEVINFO_PART	R	Part Info
0x008	DEVINFO_MEMINFO	R	Memory Info
0x00C	DEVINFO_MSIZ	R	Memory Size
0x010	DEVINFO_PKGINFO	R	Misc Device Info
0x014	DEVINFO_CUSTOMINFO	R	Custom Part Info
0x018	DEVINFO_SWFIX	R	SW Fix Register
0x01C	DEVINFO_SWCAPA0	R	Software Restriction
0x020	DEVINFO_SWCAPA1	R	Software Restriction
0x028	DEVINFO_EXTINFO	R	External Component Info
0x040	DEVINFO_EUI48L	R	EUI 48 Low
0x044	DEVINFO_EUI48H	R	EUI 48 High
0x048	DEVINFO_EUI64L	R	EUI64 Low
0x04C	DEVINFO_EUI64H	R	EUI64 High
0x050	DEVINFO_CALTEMP	R	Calibration Temperature
0x054	DEVINFO_EMUTEMP	R	EMU Temp
0x058	DEVINFO_HFRCODPLL _{CALn}	R	HFRCODPLL Calibration
0x0A0	DEVINFO_HFR _{COEM23CALn}	R	HFR _{COEM23} Calibration
0x130	DEVINFO_MODULENAME0	R	Module Name Information
0x134	DEVINFO_MODULENAME1	R	Module Name Information
0x138	DEVINFO_MODULENAME2	R	Module Name Information
0x13C	DEVINFO_MODULENAME3	R	Module Name Information
0x140	DEVINFO_MODULENAME4	R	Module Name Information
0x144	DEVINFO_MODULENAME5	R	Module Name Information
0x148	DEVINFO_MODULENAME6	R	Module Name Information
0x14C	DEVINFO_MODULEINFO	R	Module Information
0x150	DEVINFO_MODXOCAL	R	Module External Oscillator Calibration Information
0x180	DEVINFO_IADC0GAIN0	R	IADC Gain Calibration
0x184	DEVINFO_IADC0GAIN1	R	IADC Gain Calibration
0x188	DEVINFO_IADC0OFFSETCAL0	R	IADC Offset Calibration
0x18C	DEVINFO_IADC0NORMALOFF- SETCAL0	R	IADC Offset Calibration
0x190	DEVINFO_IADC0NORMALOFF- SETCAL1	R	IADC Offset Calibration
0x194	DEVINFO_IADC0HISPD _{OFF- SETCAL0}	R	IADC Offset Calibration

Offset	Name	Type	Description
0x198	DEVINFO_IADC0HISPDFF-SETCAL1	R	IADC Offset Calibration
0x1FC	DEVINFO_LEGACY	R	Legacy Device Info
0x25C	DEVINFO_RTHERM	R	Thermistor Calibration
0x264	DEVINFO_FENOTCHCAL	R	FENOTCH Calibration

6.4.2 DEVINFO Register Description

6.4.2.1 DEVINFO_INFO - DI Information

Offset	Bit Position																															
0x000	31	30	29	28	27	26	25	24	23	22	21	20	19	18	17	16	15	14	13	12	11	10	9	8	7	6	5	4	3	2	1	0
Reset	0xB								0x0								0x0															
Access	R								R								R															
Name	DEVINFOREV								PRODREV								CRC															

Bit	Name	Reset	Access	Description
31:24	DEVINFOREV	0xB	R	DI Page Version DEVINFO layout revision as unsigned integer (initially 1)
23:16	PRODREV	0x0	R	Production Revision Production revision as unsigned integer
15:0	CRC	0x0	R	CRC CRC of DI-page (CRC-16-CCITT)

6.4.2.2 DEVINFO_PART - Part Info

Offset	Bit Position																																
0x004	31	30	29	28	27	26	25	24	23	22	21	20	19	18	17	16	15	14	13	12	11	10	9	8	7	6	5	4	3	2	1	0	
Reset					0x0								0x0												0x0								
Access					R								R												R								
Name					FAMILY								FAMILYNUM												DEVICENUM								

Bit	Name	Reset	Access	Description
31:30	<i>Reserved</i>	<i>To ensure compatibility with future devices, always write Reserved bits to their reset value, unless otherwise stated. More information in 1.2 Conventions</i>		
29:24	FAMILY	0x0	R	Device Family Encoded portion of the Device Family
	Value	Mode		Description
	0	FG		Flex Gecko
	1	MG		Mighty Gecko
	2	BG		Blue Gecko
23:22	<i>Reserved</i>	<i>To ensure compatibility with future devices, always write Reserved bits to their reset value, unless otherwise stated. More information in 1.2 Conventions</i>		
21:16	FAMILYNUM	0x0	R	Device Family Numeric portion of the Device Family
15:0	DEVICENUM	0x0	R	Device Number Device Number. The device number is one letter and 3 digits. NUMBER = (alpha-'A')*1000 + numeric. 0 = A000; 1123 = B123

6.4.2.3 DEVINFO_MEMINFO - Memory Info

Offset	Bit Position																															
0x008	31	30	29	28	27	26	25	24	23	22	21	20	19	18	17	16	15	14	13	12	11	10	9	8	7	6	5	4	3	2	1	0
Reset	0x0																0x0								0x0							
Access	R																R								R							
Name	DILEN																UDPAGESIZE								FLASHPAGESIZE							

Bit	Name	Reset	Access	Description
31:16	DILEN	0x0	R	Length of DI Page Length of DI area (number of 32-bit words included in CRC)
15:8	UDPAGESIZE	0x0	R	User Data Page Size User Data page size
7:0	FLASHPAGESIZE	0x0	R	Flash Page Size Flash page size in bytes coded as $2^{\wedge}((MEMINFO.PAGESIZE + 10) \& 0xFF)$. For example, the value of 0xFF = 512 bytes

6.4.2.4 DEVINFO_MSIZ - Memory Size

Offset	Bit Position																															
0x00C	31	30	29	28	27	26	25	24	23	22	21	20	19	18	17	16	15	14	13	12	11	10	9	8	7	6	5	4	3	2	1	0
Reset	0x0																0x0															
Access	R																R															
Name	SRAM																FLASH															

Bit	Name	Reset	Access	Description
31:27	<i>Reserved</i>	<i>To ensure compatibility with future devices, always write Reserved bits to their reset value, unless otherwise stated. More information in 1.2 Conventions</i>		
26:16	SRAM	0x0	R	Sram Size Ram size, kbyte count as unsigned integer (eg 16)
15:0	FLASH	0x0	R	Flash Size Flash size, kbyte count as unsigned integer (eg. 128)

6.4.2.5 DEVINFO_PKGINFO - Misc Device Info

Offset	Bit Position																															
0x010	31	30	29	28	27	26	25	24	23	22	21	20	19	18	17	16	15	14	13	12	11	10	9	8	7	6	5	4	3	2	1	0
Reset									0x0								0x0								0x0							
Access									R								R								R							
Name									PINCOUNT								PKGTYPE								TEMPGRADE							

Bit	Name	Reset	Access	Description
31:24	<i>Reserved</i>	<i>To ensure compatibility with future devices, always write Reserved bits to their reset value, unless otherwise stated. More information in 1.2 Conventions</i>		
23:16	PINCOUNT	0x0	R	Pin Count Device pin count as unsigned integer (eg. 48)
15:8	PKGTYPE	0x0	R	Package Type Package identifier as character
	Value	Mode		Description
	74	WLCSP		WLCSP package
	76	BGA		BGA package
	77	QFN		QFN package
	81	QFP		QFP package
7:0	TEMPGRADE	0x0	R	Temperature Grade Temperature Grade of product as unsigned integer enumeration
	Value	Mode		Description
	0	N40TO85		-40 to 85 degC
	1	N40TO125		-40 to 125 degC
	2	N40TO105		-40 to 105 degC
	3	N0TO70		0 to 70 degC

6.4.2.6 DEVINFO_CUSTOMINFO - Custom Part Info

Offset	Bit Position																															
0x014	31	30	29	28	27	26	25	24	23	22	21	20	19	18	17	16	15	14	13	12	11	10	9	8	7	6	5	4	3	2	1	0
Reset	0x0																															
Access	R																															
Name	PARTNO																															

Bit	Name	Reset	Access	Description
31:16	PARTNO	0x0	R	Part Number Custom part identifier as unsigned integer (eg. 903). 65535 for standard product
15:0	<i>Reserved</i>	<i>To ensure compatibility with future devices, always write Reserved bits to their reset value, unless otherwise stated. More information in 1.2 Conventions</i>		

6.4.2.7 DEVINFO_SWFIX - SW Fix Register

Offset	Bit Position																															
0x018	31	30	29	28	27	26	25	24	23	22	21	20	19	18	17	16	15	14	13	12	11	10	9	8	7	6	5	4	3	2	1	0
Reset																	0xFFFFFFFF															
Access																	R															
Name																	RSV															

Bit	Name	Reset	Access	Description
31:0	RSV	0xFFFFFFFF FF	R	Reserved Reserved for future use

6.4.2.8 DEVINFO_SWCAPA0 - Software Restriction

Offset	Bit Position																																									
0x01C	31	30	29	28	27	26	25	24	23	22	21	20	19	18	17	16	15	14	13	12	11	10	9	8	7	6	5	4	3	2	1	0										
Reset						0x0						0x0						0x0						0x0						0x0												
Access						R						R						R						R						R												
Name						ZWAVE						SRI						CONNECT						BTSMART						RF4CE						THREAD						ZIGBEE

Bit	Name	Reset	Access	Description
31:27	<i>Reserved</i>	<i>To ensure compatibility with future devices, always write Reserved bits to their reset value, unless otherwise stated. More information in 1.2 Conventions</i>		
26:24	ZWAVE	0x0	R	Z-Wave Capability Z-Wave Stack Capability
	Value	Mode		Description
	0	LEVEL0		Z-Wave stack capability not available
	1	LEVEL1		Z-Wave Gateway
	2	LEVEL2		Z-Wave End Device
	3	LEVEL3		Z-Wave Sensor
	4	LEVEL4		Z-Wave Lighting
23:22	<i>Reserved</i>	<i>To ensure compatibility with future devices, always write Reserved bits to their reset value, unless otherwise stated. More information in 1.2 Conventions</i>		
21:20	SRI	0x0	R	RAIL Capability RAIL capability not available
	Value	Mode		Description
	0	LEVEL0		RAIL capability not available
	1	LEVEL1		RAIL enabled
	2	LEVEL2		N/A
	3	LEVEL3		N/A
19:18	<i>Reserved</i>	<i>To ensure compatibility with future devices, always write Reserved bits to their reset value, unless otherwise stated. More information in 1.2 Conventions</i>		
17:16	CONNECT	0x0	R	Connect Capability Connect stack capability level
	Value	Mode		Description
	0	LEVEL0		Connect stack capability not available
	1	LEVEL1		Connect enabled
	2	LEVEL2		N/A
	3	LEVEL3		N/A

Bit	Name	Reset	Access	Description
15:14	<i>Reserved</i>	<i>To ensure compatibility with future devices, always write Reserved bits to their reset value, unless otherwise stated. More information in 1.2 Conventions</i>		
13:12	BTSMART	0x0	R	Bluetooth Smart Capability
	Bluetooth SMART stack capability level			
	Value	Mode	Description	
	0	LEVEL0	Bluetooth SMART stack capability not available	
	1	LEVEL1	Bluetooth SMART enabled	
	2	LEVEL2	N/A	
	3	LEVEL3	N/A	
11:10	<i>Reserved</i>	<i>To ensure compatibility with future devices, always write Reserved bits to their reset value, unless otherwise stated. More information in 1.2 Conventions</i>		
9:8	RF4CE	0x0	R	RF4CE Capability
	RF4CE stack capability level			
	Value	Mode	Description	
	0	LEVEL0	Thread stack capability not available	
	1	LEVEL1	Thread stack enabled	
	2	LEVEL2	N/A	
	3	LEVEL3	N/A	
7:6	<i>Reserved</i>	<i>To ensure compatibility with future devices, always write Reserved bits to their reset value, unless otherwise stated. More information in 1.2 Conventions</i>		
5:4	THREAD	0x0	R	Thread Capability
	Thread stack capability level			
	Value	Mode	Description	
	0	LEVEL0	RF4CE stack capability not available	
	1	LEVEL1	RF4CE stack enabled	
	2	LEVEL2	N/A	
	3	LEVEL3	N/A	
3:2	<i>Reserved</i>	<i>To ensure compatibility with future devices, always write Reserved bits to their reset value, unless otherwise stated. More information in 1.2 Conventions</i>		
1:0	ZIGBEE	0x0	R	ZigBee Capability
	ZigBee stack capability level			
	Value	Mode	Description	
	0	LEVEL0	ZigBee stack capability not available	
	1	LEVEL1	GreenPower only	
	2	LEVEL2	ZigBee and GreenPower	
	3	LEVEL3	ZigBee Only	

6.4.2.9 DEVINFO_SWCAPA1 - Software Restriction

Offset	Bit Position																															
0x020	31	30	29	28	27	26	25	24	23	22	21	20	19	18	17	16	15	14	13	12	11	10	9	8	7	6	5	4	3	2	1	0
Reset																											0x0	0x0	0x0	0x0	0x0	
Access																											R	R	R	R	R	
Name																											FENOTCH	XOUT	GWEN	NCPEN	RFMCUEN	

Bit	Name	Reset	Access	Description
31:5	<i>Reserved</i>	<i>To ensure compatibility with future devices, always write Reserved bits to their reset value, unless otherwise stated. More information in 1.2 Conventions</i>		
4	FENOTCH FENOTCH feature available	0x0	R	FENOTCH
3	XOUT XOUT feature available	0x0	R	XOUT
2	GWEN Gateway enabled part	0x0	R	Gateway
1	NCPEN Network co-processor enabled part. NCP only if RFMCUEN = 0	0x0	R	NCP
0	RFMCUEN RF-MCU enabled part. RF-MCU only if NCPEN = 0	0x0	R	RF-MCU

6.4.2.10 DEVINFO_EXTINFO - External Component Info

Offset	Bit Position																															
0x028	31	30	29	28	27	26	25	24	23	22	21	20	19	18	17	16	15	14	13	12	11	10	9	8	7	6	5	4	3	2	1	0
Reset									0x0								0x0								0x0							
Access									R								R								R							
Name									REV								CONNECTION								TYPE							

Bit	Name	Reset	Access	Description
31:24	<i>Reserved</i>	<i>To ensure compatibility with future devices, always write Reserved bits to their reset value, unless otherwise stated. More information in 1.2 Conventions</i>		
23:16	REV MCM Revision	0x0	R	Revision
15:8	CONNECTION Connection protocol to external interface	0x0	R	Connection
	Value	Mode		Description
	0	SPI		SPI control interface
	255	NONE		No interface
7:0	TYPE External Component	0x0	R	Type
	Value	Mode		Description
	255	NONE		

6.4.2.11 DEVINFO_EUI48L - EUI 48 Low

Offset	Bit Position																															
0x040	31	30	29	28	27	26	25	24	23	22	21	20	19	18	17	16	15	14	13	12	11	10	9	8	7	6	5	4	3	2	1	0
Reset	0x0																0x0															
Access	R																R															
Name	OUI48L																UNIQUEID															

Bit	Name	Reset	Access	Description
31:24	OUI48L	0x0	R	OUI48L Lower Octet of EUI48 Organizationally Unique Identifier
23:0	UNIQUEID	0x0	R	Unique ID Unique identifier

6.4.2.12 DEVINFO_EUI48H - EUI 48 High

Offset	Bit Position																															
0x044	31	30	29	28	27	26	25	24	23	22	21	20	19	18	17	16	15	14	13	12	11	10	9	8	7	6	5	4	3	2	1	0
Reset	0xFFFF																0x0															
Access	R																R															
Name	RESERVED																OUI48H															

Bit	Name	Reset	Access	Description
31:16	RESERVED	0xFFFF	R	RESERVED Reserved
15:0	OUI48H	0x0	R	OUI48H Upper two Octets of EUI48 OUI

6.4.2.13 DEVINFO_EUI64L - EUI64 Low

Offset	Bit Position																															
0x048	31	30	29	28	27	26	25	24	23	22	21	20	19	18	17	16	15	14	13	12	11	10	9	8	7	6	5	4	3	2	1	0
Reset																	0x0															
Access																	R															
Name																	UNIQUEL															

Bit	Name	Reset	Access	Description
31:0	UNIQUEL	0x0	R	UNIQUEL Lower 32 bits of EUI64 Unique Identifier

6.4.2.14 DEVINFO_EUI64H - EUI64 High

Offset	Bit Position																															
0x04C	31	30	29	28	27	26	25	24	23	22	21	20	19	18	17	16	15	14	13	12	11	10	9	8	7	6	5	4	3	2	1	0
Reset																	0x0								0x0							
Access																	R								R							
Name																	OUI64								UNIQUEH							

Bit	Name	Reset	Access	Description
31:8	OUI64	0x0	R	OUI64 24-bit OUI identifier
7:0	UNIQUEH	0x0	R	UNIQUEH Upper 8 bits of EUI64 unique identifier

6.4.2.15 DEVINFO_CALTEMP - Calibration Temperature

Offset	Bit Position																															
0x050	31	30	29	28	27	26	25	24	23	22	21	20	19	18	17	16	15	14	13	12	11	10	9	8	7	6	5	4	3	2	1	0
Reset																									0x0							
Access																									R							
Name																									TEMP							

Bit	Name	Reset	Access	Description
31:8	Reserved	To ensure compatibility with future devices, always write Reserved bits to their reset value, unless otherwise stated. More information in 1.2 Conventions		
7:0	TEMP	0x0	R	Cal Temp Calibration temperature as an unsigned int in DegC. (0x19 = 25DegC)

6.4.2.16 DEVINFO_EMUTEMP - EMU Temp

Offset	Bit Position																															
0x054	31	30	29	28	27	26	25	24	23	22	21	20	19	18	17	16	15	14	13	12	11	10	9	8	7	6	5	4	3	2	1	0
Reset																									0x0							
Access																									R							
Name																									EMUTEMPROOM							

Bit	Name	Reset	Access	Description
31:11	Reserved	To ensure compatibility with future devices, always write Reserved bits to their reset value, unless otherwise stated. More information in 1.2 Conventions		
10:2	EMUTEMPROOM	0x0	R	Emu Room Temperature EMU_TEMP temperature reading at room (calibration) temperature.
1:0	Reserved	To ensure compatibility with future devices, always write Reserved bits to their reset value, unless otherwise stated. More information in 1.2 Conventions		

6.4.2.17 DEVINFO_HFRCODPLLCALn - HFRCODPLL Calibration

Offset	Bit Position																																
0x058	31	30	29	28	27	26	25	24	23	22	21	20	19	18	17	16	15	14	13	12	11	10	9	8	7	6	5	4	3	2	1	0	
Reset	0x0			0x0			0x0			0x0			0x0			0x0			0x0			0x0			0x0			0x0			0x0		
Access	R			R			R			R			R			R			R			R			R			R			R		
Name	IREFTC			CMPSEL			CLKDIV			CMPBIAS			FREQRANGE			LDOHP			FINETUNING									TUNING					

Bit	Name	Reset	Access	Description
31:28	IREFTC Tempco Trim	0x0	R	
27:26	CMPSEL Comparator Load Select	0x0	R	
25:24	CLKDIV Locally Divide HFRCO Clock Output	0x0	R	
23:21	CMPBIAS Comparator Bias Current	0x0	R	
20:16	FREQRANGE Frequency Range	0x0	R	
15	LDOHP LDO High Power Mode	0x0	R	
14	<i>Reserved</i>	<i>To ensure compatibility with future devices, always write Reserved bits to their reset value, unless otherwise stated. More information in 1.2 Conventions</i>		
13:8	FINETUNING Fine Tuning Value	0x0	R	
7	<i>Reserved</i>	<i>To ensure compatibility with future devices, always write Reserved bits to their reset value, unless otherwise stated. More information in 1.2 Conventions</i>		
6:0	TUNING Tuning Value	0x0	R	

6.4.2.18 DEVINFO_HFRCOEM23CALn - HFRCOEM23 Calibration

Offset	Bit Position																																
0x0A0	31	30	29	28	27	26	25	24	23	22	21	20	19	18	17	16	15	14	13	12	11	10	9	8	7	6	5	4	3	2	1	0	
Reset	0x0			0x0			0x0			0x0			0x0			0x0			0x0			0x0			0x0			0x0			0x0		
Access	R			R			R			R			R			R			R			R			R			R			R		
Name	IREFTC			CMPSEL			CLKDIV			CMPBIAS			FREQRANGE			LDOHP			FINETUNING			FINETUNING			FINETUNING			TUNING			TUNING		

Bit	Name	Reset	Access	Description
31:28	IREFTC Tempco Trim	0x0	R	
27:26	CMPSEL Comparator Load Select	0x0	R	
25:24	CLKDIV Locally Divide HFRCO Clock Output	0x0	R	
23:21	CMPBIAS Comparator Bias Current	0x0	R	
20:16	FREQRANGE Frequency Range	0x0	R	
15	LDOHP LDO High Power Mode	0x0	R	
14	<i>Reserved</i>	<i>To ensure compatibility with future devices, always write Reserved bits to their reset value, unless otherwise stated. More information in 1.2 Conventions</i>		
13:8	FINETUNING Fine Tuning Value	0x0	R	
7	<i>Reserved</i>	<i>To ensure compatibility with future devices, always write Reserved bits to their reset value, unless otherwise stated. More information in 1.2 Conventions</i>		
6:0	TUNING Tuning Value	0x0	R	

6.4.2.19 DEVINFO_MODULENAME0 - Module Name Information

Offset	Bit Position																															
0x130	31	30	29	28	27	26	25	24	23	22	21	20	19	18	17	16	15	14	13	12	11	10	9	8	7	6	5	4	3	2	1	0
Reset	0xFF								0xFF								0xFF								0xFF							
Access	R								R								R								R							
Name	MODCHAR4								MODCHAR3								MODCHAR2								MODCHAR1							

Bit	Name	Reset	Access	Description
31:24	MODCHAR4	0xFF	R	Fourth character of Module Name, 0xFF = unwritten, 0x00 = character not used in name
23:16	MODCHAR3	0xFF	R	Third character of Module Name, 0xFF = unwritten, 0x00 = character not used in name
15:8	MODCHAR2	0xFF	R	Second character of Module Name, 0xFF = unwritten, 0x00 = character not used in name
7:0	MODCHAR1	0xFF	R	First character of Module Name, 0xFF = unwritten, 0x00 = character not used in name

6.4.2.20 DEVINFO_MODULENAME1 - Module Name Information

Offset	Bit Position																															
0x134	31	30	29	28	27	26	25	24	23	22	21	20	19	18	17	16	15	14	13	12	11	10	9	8	7	6	5	4	3	2	1	0
Reset	0xFF								0xFF								0xFF								0xFF							
Access	R								R								R								R							
Name	MODCHAR8								MODCHAR7								MODCHAR6								MODCHAR5							

Bit	Name	Reset	Access	Description
31:24	MODCHAR8	0xFF	R	Character of Module Name, 0xFF = unwritten, 0x00 = character not used in name
23:16	MODCHAR7	0xFF	R	Character of Module Name, 0xFF = unwritten, 0x00 = character not used in name
15:8	MODCHAR6	0xFF	R	Character of Module Name, 0xFF = unwritten, 0x00 = character not used in name
7:0	MODCHAR5	0xFF	R	Character of Module Name, 0xFF = unwritten, 0x00 = character not used in name

6.4.2.21 DEVINFO_MODULENAME2 - Module Name Information

Offset	Bit Position																															
0x138	31	30	29	28	27	26	25	24	23	22	21	20	19	18	17	16	15	14	13	12	11	10	9	8	7	6	5	4	3	2	1	0
Reset	0xFF								0xFF								0xFF								0xFF							
Access	R								R								R								R							
Name	MODCHAR12								MODCHAR11								MODCHAR10								MODCHAR9							

Bit	Name	Reset	Access	Description
31:24	MODCHAR12	0xFF	R	Character of Module Name, 0xFF = unwritten, 0x00 = character not used in name
23:16	MODCHAR11	0xFF	R	Character of Module Name, 0xFF = unwritten, 0x00 = character not used in name
15:8	MODCHAR10	0xFF	R	Character of Module Name, 0xFF = unwritten, 0x00 = character not used in name
7:0	MODCHAR9	0xFF	R	Character of Module Name, 0xFF = unwritten, 0x00 = character not used in name

6.4.2.22 DEVINFO_MODULENAME3 - Module Name Information

Offset	Bit Position																															
0x13C	31	30	29	28	27	26	25	24	23	22	21	20	19	18	17	16	15	14	13	12	11	10	9	8	7	6	5	4	3	2	1	0
Reset	0xFF								0xFF								0xFF								0xFF							
Access	R								R								R								R							
Name	MODCHAR16								MODCHAR15								MODCHAR14								MODCHAR13							

Bit	Name	Reset	Access	Description
31:24	MODCHAR16	0xFF	R	Character of Module Name, 0xFF = unwritten, 0x00 = character not used in name
23:16	MODCHAR15	0xFF	R	Character of Module Name, 0xFF = unwritten, 0x00 = character not used in name
15:8	MODCHAR14	0xFF	R	Character of Module Name, 0xFF = unwritten, 0x00 = character not used in name
7:0	MODCHAR13	0xFF	R	Character of Module Name, 0xFF = unwritten, 0x00 = character not used in name

6.4.2.23 DEVINFO_MODULENAME4 - Module Name Information

Offset	Bit Position																															
0x140	31	30	29	28	27	26	25	24	23	22	21	20	19	18	17	16	15	14	13	12	11	10	9	8	7	6	5	4	3	2	1	0
Reset	0xFF								0xFF								0xFF								0xFF							
Access	R								R								R								R							
Name	MODCHAR20								MODCHAR19								MODCHAR18								MODCHAR17							

Bit	Name	Reset	Access	Description
31:24	MODCHAR20	0xFF	R	Character of Module Name, 0xFF = unwritten, 0x00 = character not used in name
23:16	MODCHAR19	0xFF	R	Character of Module Name, 0xFF = unwritten, 0x00 = character not used in name
15:8	MODCHAR18	0xFF	R	Character of Module Name, 0xFF = unwritten, 0x00 = character not used in name
7:0	MODCHAR17	0xFF	R	Character of Module Name, 0xFF = unwritten, 0x00 = character not used in name

6.4.2.24 DEVINFO_MODULENAME5 - Module Name Information

Offset	Bit Position																															
0x144	31	30	29	28	27	26	25	24	23	22	21	20	19	18	17	16	15	14	13	12	11	10	9	8	7	6	5	4	3	2	1	0
Reset	0xFF								0xFF								0xFF								0xFF							
Access	R								R								R								R							
Name	MODCHAR24								MODCHAR23								MODCHAR22								MODCHAR21							

Bit	Name	Reset	Access	Description
31:24	MODCHAR24	0xFF	R	Character of Module Name, 0xFF = unwritten, 0x00 = character not used in name
23:16	MODCHAR23	0xFF	R	Character of Module Name, 0xFF = unwritten, 0x00 = character not used in name
15:8	MODCHAR22	0xFF	R	Character of Module Name, 0xFF = unwritten, 0x00 = character not used in name
7:0	MODCHAR21	0xFF	R	Character of Module Name, 0xFF = unwritten, 0x00 = character not used in name

6.4.2.25 DEVINFO_MODULENAME6 - Module Name Information

Offset	Bit Position																															
0x148	31	30	29	28	27	26	25	24	23	22	21	20	19	18	17	16	15	14	13	12	11	10	9	8	7	6	5	4	3	2	1	0
Reset	0xFFFF																0xFF								0xFF							
Access	R																R								R							
Name	RSV																MODCHAR26								MODCHAR25							

Bit	Name	Reset	Access	Description
31:16	RSV	0xFFFF	R	Reserved for future use
15:8	MODCHAR26	0xFF	R	Last possible character of module name, 0xFF = unwritten, 0x00 = character not used in name
7:0	MODCHAR25	0xFF	R	0xFF = unwritten, 0x00 = character not used in name

6.4.2.26 DEVINFO_MODULEINFO - Module Information

Offset	Bit Position																																						
0x14C	31	30	29	28	27	26	25	24	23	22	21	20	19	18	17	16	15	14	13	12	11	10	9	8	7	6	5	4	3	2	1	0							
Reset	0x1	0x1	0x1						0x1FF					0x1	0x1	0x1	0x1	0x1						0x7F					0x7			0x1F							
Access	R	R	R						R						R	R	R	R	R						R						R				R				
Name	EXTVALID	PHYLIMITED	PADCDC						MODNUMBERMSB						HFXOCALVAL	LFXOCALVAL	EXPRESS	LFXO	TYPE						MODNUMBER						ANTENNA				HWREV				

Bit	Name	Reset	Access	Description
31	EXTVALID	0x1	R	EXTINFO entry used
	Value	Mode		Description
	0	EXTUSED		
	1	EXTUNUSED		
30	PHYLIMITED	0x1	R	PHY Limited
	Value	Mode		Description
	0	LIMITED		
	1	UNLIMITED		
29	PADCDC	0x1	R	PAVDD Connection
	Value	Mode		Description
	0	VDCDC		
	1	OTHER		
28:20	MODNUMBERMSB	0x1FF	R	Counter allowing unique identification of module per lookup when combined with MODNUMBER
19	HFXOCALVAL	0x1	R	HFXO Factory Calibrated
	Value	Mode		Description
	0	VALID		
	1	NOTVALID		
18	LFXOCALVAL	0x1	R	

Bit	Name	Reset	Access	Description
	LFXO Factory Calibrated			
	Value	Mode		Description
	0	VALID		
	1	NOTVALID		
17	EXPRESS	0x1	R	
	Blue Gecko Express			
	Value	Mode		Description
	0	SUPPORTED		
	1	NONE		
16	LFXO	0x1	R	
	Module has LFXO			
	Value	Mode		Description
	0	NONE		
	1	PRESENT		
15	TYPE	0x1	R	
	Module Type			
	Value	Mode		Description
	0	PCB		
	1	SIP		
14:8	MODNUMBER	0x7F	R	
	Counter allowing unique identification of module per lookup when combined with MODNUMBER MSB			
7:5	ANTENNA	0x7	R	
	Module Antenna Type			
	Value	Mode		Description
	0	BUILTIN		None
	1	CONNECTOR		
	2	RFPAD		
	3	INVERTEDF		
4:0	HWREV	0x1F	R	
	Module Hardware Revision. Starting from 0			

6.4.2.27 DEVINFO_MODXOCAL - Module External Oscillator Calibration Information

Offset	Bit Position																																
	31	30	29	28	27	26	25	24	23	22	21	20	19	18	17	16	15	14	13	12	11	10	9	8	7	6	5	4	3	2	1	0	
0x150																																	
Reset											0x7F								0xFF								0xFF						
Access											R								R								R						
Name											LFXOCAPTUNE								HFXOCTUNEXOANA								HFXOCTUNEXIANA						

Bit	Name	Reset	Access	Description
31:23	Reserved			To ensure compatibility with future devices, always write Reserved bits to their reset value, unless otherwise stated. More information in 1.2 Conventions
22:16	LFXOCAPTUNE LFXO Cap Tuning	0x7F	R	
15:8	HFXOCTUNEXOANA Tuning capacitance on XO	0xFF	R	
7:0	HFXOCTUNEXIANA Tuning capacitance on XI	0xFF	R	

6.4.2.28 DEVINFO_IADC0GAIN0 - IADC Gain Calibration

Offset	Bit Position																															
	31	30	29	28	27	26	25	24	23	22	21	20	19	18	17	16	15	14	13	12	11	10	9	8	7	6	5	4	3	2	1	0
0x180																																
Reset	0x0																0x0															
Access	R																R															
Name	GAINCANA2																GAINCANA1															

Bit	Name	Reset	Access	Description
31:16	GAINCANA2 Input Gain = 2x	0x0	R	
15:0	GAINCANA1 Input Gain = 1x and 0.5x	0x0	R	

6.4.2.29 DEVINFO_IADC0GAIN1 - IADC Gain Calibration

Offset	Bit Position																															
0x184	31	30	29	28	27	26	25	24	23	22	21	20	19	18	17	16	15	14	13	12	11	10	9	8	7	6	5	4	3	2	1	0
Reset	0x0																0x0															
Access	R																R															
Name	GAINCANA4																GAINCANA3															

Bit	Name	Reset	Access	Description
31:16	GAINCANA4	0x0	R	Input Gain = 4x
15:0	GAINCANA3	0x0	R	Input Gain = 3x

6.4.2.30 DEVINFO_IADC0OFFSETCAL0 - IADC Offset Calibration

Offset	Bit Position																															
0x188	31	30	29	28	27	26	25	24	23	22	21	20	19	18	17	16	15	14	13	12	11	10	9	8	7	6	5	4	3	2	1	0
Reset	0x0																0x0															
Access	R																R															
Name	OFFSETANA1HIACC																OFFSETANABASE															

Bit	Name	Reset	Access	Description
31:16	OFFSETANA1HIACC	0x0	R	High-accuracy OSR adjustment term
15:0	OFFSETANABASE	0x0	R	Base analog offset term

6.4.2.31 DEVINFO_IADC0NORMALOFFSETCAL0 - IADC Offset Calibration

Offset	Bit Position																															
0x18C	31	30	29	28	27	26	25	24	23	22	21	20	19	18	17	16	15	14	13	12	11	10	9	8	7	6	5	4	3	2	1	0
Reset	0x0																0x0															
Access	R																R															
Name	OFFSETANA2NORM																OFFSETANA1NORM															

Bit	Name	Reset	Access	Description
31:16	OFFSETANA2NORM	0x0	R	Normal mode offset gain adjustment term
15:0	OFFSETANA1NORM	0x0	R	Normal mode analog offset term at OSR=2x, gain = 1x

6.4.2.32 DEVINFO_IADC0NORMALOFFSETCAL1 - IADC Offset Calibration

Offset	Bit Position																															
0x190	31	30	29	28	27	26	25	24	23	22	21	20	19	18	17	16	15	14	13	12	11	10	9	8	7	6	5	4	3	2	1	0
Reset																	0x0															
Access																	R															
Name																	OFFSETANA3NORM															

Bit	Name	Reset	Access	Description
31:16	Reserved	To ensure compatibility with future devices, always write Reserved bits to their reset value, unless otherwise stated. More information in 1.2 Conventions		
15:0	OFFSETANA3NORM	0x0	R	Normal mode offset term for OSR>=4x

6.4.2.33 DEVINFO_IADC0HISPD OFFSETCAL0 - IADC Offset Calibration

Offset	Bit Position																															
0x194	31	30	29	28	27	26	25	24	23	22	21	20	19	18	17	16	15	14	13	12	11	10	9	8	7	6	5	4	3	2	1	0
Reset	0x0																0x0															
Access	R																R															
Name	OFFSETANA2HISPD																OFFSETANA1HISPD															

Bit	Name	Reset	Access	Description
31:16	OFFSETANA2HISPD	0x0	R	High speed mode offset gain adjustment term
15:0	OFFSETANA1HISPD	0x0	R	High speed mode analog offset term at OSR=2x, gain = 1x

6.4.2.34 DEVINFO_IADC0HISPD OFFSETCAL1 - IADC Offset Calibration

Offset	Bit Position																															
0x198	31	30	29	28	27	26	25	24	23	22	21	20	19	18	17	16	15	14	13	12	11	10	9	8	7	6	5	4	3	2	1	0
Reset																	0x0															
Access																	R															
Name																	OFFSETANA3HISPD															

Bit	Name	Reset	Access	Description
31:16	<i>Reserved</i>	<i>To ensure compatibility with future devices, always write Reserved bits to their reset value, unless otherwise stated. More information in 1.2 Conventions</i>		
15:0	OFFSETANA3HISPD	0x0	R	High-speed mode offset term for OSR>=4x

6.4.2.35 DEVINFO_LEGACY - Legacy Device Info

Offset	Bit Position																															
0x1FC	31	30	29	28	27	26	25	24	23	22	21	20	19	18	17	16	15	14	13	12	11	10	9	8	7	6	5	4	3	2	1	0
Reset									0x80																							
Access									R																							
Name									DEVICEFAMILY																							

Bit	Name	Reset	Access	Description
31:24	Reserved	To ensure compatibility with future devices, always write Reserved bits to their reset value, unless otherwise stated. More information in 1.2 Conventions		
23:16	DEVICEFAMILY	0x80	R	Device Family
	Device Family			
	Value	Mode		Description
	16	EFR32MG1P		EFR32 Mighty Gecko Family Series 1 Device Config 1
	17	EFR32MG1B		EFR32 Mighty Gecko Family Series 1 Device Config 1
	18	EFR32MG1V		EFR32 Mighty Gecko Family Series 1 Device Config 1
	19	EFR32BG1P		EFR32 Blue Gecko Family Series 1 Device Config 1
	20	EFR32BG1B		EFR32 Blue Gecko Family Series 1 Device Config 1
	21	EFR32BG1V		EFR32 Blue Gecko Family Series 1 Device Config 1
	25	EFR32FG1P		EFR32 Flex Gecko Family Series 1 Device Config 1
	26	EFR32FG1B		EFR32 Flex Gecko Family Series 1 Device Config 1
	27	EFR32FG1V		EFR32 Flex Gecko Family Series 1 Device Config 1
	28	EFR32MG12P		EFR32 Mighty Gecko Family Series 1 Device Config 2
	29	EFR32MG12B		EFR32 Mighty Gecko Family Series 1 Device Config 2
	30	EFR32MG12V		EFR32 Mighty Gecko Family Series 1 Device Config 2
	31	EFR32BG12P		EFR32 Blue Gecko Family Series 1 Device Config 2
	32	EFR32BG12B		EFR32 Blue Gecko Family Series 1 Device Config 2
	33	EFR32BG12V		EFR32 Blue Gecko Family Series 1 Device Config 2
	37	EFR32FG12P		EFR32 Flex Gecko Family Series 1 Device Config 2
	38	EFR32FG12B		EFR32 Flex Gecko Family Series 1 Device Config 2
	39	EFR32FG12V		EFR32 Flex Gecko Family Series 1 Device Config 2
	40	EFR32MG13P		EFR32 Mighty Gecko Family Series 13 Device Config 3
	41	EFR32MG13B		EFR32 Mighty Gecko Family Series 13 Device Config 3
	42	EFR32MG13V		EFR32 Mighty Gecko Family Series 1 Device Config 3
	43	EFR32BG13P		EFR32 Blue Gecko Family Series 1 Device Config 3

Bit	Name	Reset	Access	Description
44		EFR32BG13B		EFR32 Blue Gecko Family Series 1 Device Config 3
45		EFR32BG13V		EFR32 Blue Gecko Family Series 1 Device Config 3
49		EFR32FG13P		EFR32 Flex Gecko Family Series 1 Device Config 3
50		EFR32FG13B		EFR32 Flex Gecko Family Series 1 Device Config 3
51		EFR32FG13V		EFR32 Flex Gecko Family Series 1 Device Config 3
52		EFR32MG14P		EFR32 Mighty Gecko Family Series 1 Device Config 4
53		EFR32MG14B		EFR32 Mighty Gecko Family Series 1 Device Config 4
54		EFR32MG14V		EFR32 Mighty Gecko Family Series 1 Device Config 4
55		EFR32BG14P		EFR32 Blue Gecko Family Series 1 Device Config 4
56		EFR32BG14B		EFR32 Blue Gecko Family Series 1 Device Config 4
57		EFR32BG14V		EFR32 Blue Gecko Family Series 1 Device Config 4
61		EFR32FG14P		EFR32 Flex Gecko Family Series 1 Device Config 4
62		EFR32FG14B		EFR32 Flex Gecko Family Series 1 Device Config 4
63		EFR32FG14V		EFR32 Flex Gecko Family Series 1 Device Config 4
71		EFM32G		EFM32 Gecko Device Family
72		EFM32GG		EFM32 Giant Gecko Device Family
73		EFM32TG		EFM32 Tiny Gecko Device Family
74		EFM32LG		EFM32 Leopard Gecko Device Family
75		EFM32WG		EFM32 Wonder Gecko Device Family
76		EFM32ZG		EFM32 Zero Gecko Device Family
77		EFM32HG		EFM32 Happy Gecko Device Family
81		EFM32PG1B		EFM32 Pearl Gecko Device Family Series 1 Device Config 1
83		EFM32JG1B		EFM32 Jade Gecko Device Family Series 1 Device Config 1
85		EFM32PG12B		EFM32 Pearl Gecko Device Family Series 1 Device Config 2
87		EFM32JG12B		EFM32 Jade Gecko Device Family Series 1 Device Config 2
89		EFM32PG13B		EFM32 Pearl Gecko Device Family Series 1 Device Config 3
91		EFM32JG13B		EFM32 Jade Gecko Device Family Series 1 Device Config 3
100		EFM32GG11B		EFM32 Giant Gecko Device Family Series 1 Device Config 1
103		EFM32TG11B		EFM32 Giant Gecko Device Family Series 1 Device Config 1
120		EZR32LG		EZR32 Leopard Gecko Device Family
121		EZR32WG		EZR32 Wonder Gecko Device Family
122		EZR32HG		EZR32 Happy Gecko Device Family
128		SERIES2V0		DI page is encoded with the series 2 layout. Check alternate location.
15:0	Reserved			To ensure compatibility with future devices, always write Reserved bits to their reset value, unless otherwise stated. More information in 1.2 Conventions

6.4.2.36 DEVINFO_RTHERM - Thermistor Calibration

Offset	Bit Position																															
0x25C	31	30	29	28	27	26	25	24	23	22	21	20	19	18	17	16	15	14	13	12	11	10	9	8	7	6	5	4	3	2	1	0
Reset																	0x0															
Access																	R															
Name																	RTHERM															

Bit	Name	Reset	Access	Description
31:16	Reserved	To ensure compatibility with future devices, always write Reserved bits to their reset value, unless otherwise stated. More information in 1.2 Conventions		
15:0	RTHERM Calibrated Thermistor Resistor	0x0	R	

6.4.2.37 DEVINFO_FENOTCHCAL - FENOTCH Calibration

Offset	Bit Position																															
0x264	31	30	29	28	27	26	25	24	23	22	21	20	19	18	17	16	15	14	13	12	11	10	9	8	7	6	5	4	3	2	1	0
Reset																	0xF								0xF							
Access																	R								R							
Name																	FENOTCHCAPFINE								FENOTCHCAPCRSE							

Bit	Name	Reset	Access	Description
31:8	Reserved	To ensure compatibility with future devices, always write Reserved bits to their reset value, unless otherwise stated. More information in 1.2 Conventions		
7:4	FENOTCHCAPFINE FENOTCH Cap Fine Trim	0xF	R	Cap Fine
3:0	FENOTCHCAPCRSE FENOTCH Cap Coarse Trim	0xF	R	Cap Coarse

6.5 ICACHE - Instruction Cache

The ICACHE provides fast access to recently executed instructions, improving both speed and power consumption of code execution. The instruction cache is enabled by default, but can be disabled by setting CACHEDIS in ICACHE_CTRL. When enabled, the instruction cache typically reduces the number of flash reads significantly, thus saving energy. In most cases, a cache hit-rate of more than 70 % is achievable. When a 32-bit instruction fetch hits in the cache, the data is returned to the processor in one clock cycle, bypassing the flash access wait-states. The cache content is retained in EM2 and EM3.

The instruction cache is connected directly to the CODE bus on the ARM core and functions as a memory access filter between the processor and the memory system, as illustrated in [Figure 6.1 Instruction Cache Block Diagram on page 90](#). The cache consists of an access filter, lookup logic, SRAM, and three performance counters. The access filter checks if a transfer is an instruction fetch located in a cacheable region. If it is the cache lookup logic and SRAM is enabled. Otherwise, the cache is bypassed and the access is forwarded to the memory system. If lookup is enabled data is either returned from the cache (hit) or fetch from the memory system and cached (miss).

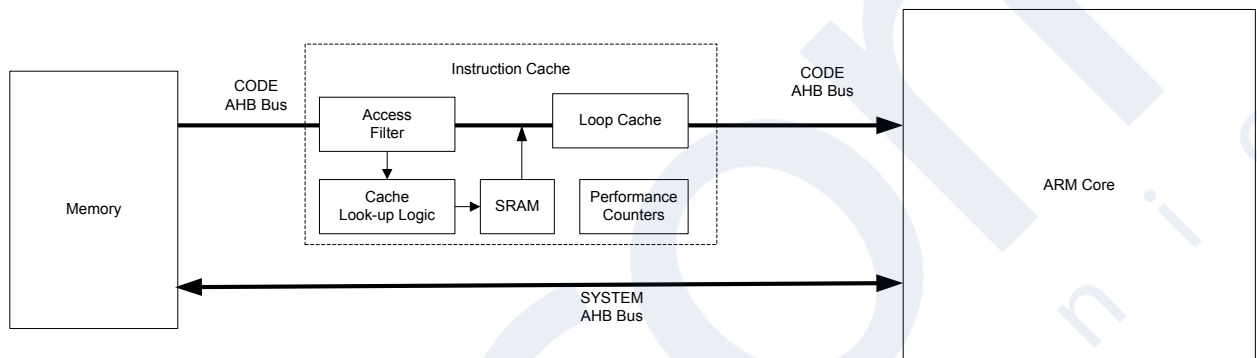

Figure 6.1. Instruction Cache Block Diagram

Note that while all access to code spaces use the CODE bus only instruction fetches are cached. Data accesses to the CODE region are passed through the ICACHE.

6.5.1 Cache Operation

It is highly recommended to keep the cache enabled. To improve cache-efficiency, sections of code with very low cache hit rate should not be cached. This is achieved by placing these code sections in non-cacheable MPU regions and setting USEMPU in ICACHE_CTRL. When USEMPU is set, instruction fetches to non-cacheable MPU regions will not be looked up or saved in cache. This feature may also be used to avoid instructions from low-power memory taking up space from more power-hungry memory. For more information on the MPU see the ARM Cortex®-M33 MPU documentation.

The optional loop-cache is optimized to store smaller code-loops efficiently. The loop-cache is enabled when LPLEVEL in ICACHE_LPMODE is set to ADVANCED or MINACTIVITY. The difference between the two settings is that when MINACTIVITY is selected loop-cache outputs may be gated off to reduce power at the cost of more wait-states due to loop-cache misses. Having LPLEVEL set to BASIC disables the loop-cache functionality completely. NESTFACTOR in ICACHE_LPMODE is used to decide when to stick with the currently detected loop rather than start tracking a new loop. Optimal value will depend on the actual code running, meaning that this setting may be tuned for optimal performance.

By default, the instruction cache is automatically invalidated when the contents of the flash are changed (i.e. written or erased). In many cases, however, the application only makes changes to data in the flash, not code. In this case, the automatic invalidate feature can be disabled by setting AUTOFLUSHDIS in ICACHE_CTRL. The cache can also be manually invalidated by writing 1 to FLUSH in ICACHE_CMD.

In the event that a parity error in the cache is detected, the RAMERROR flag will be set in ICACHE_IF. The data is automatically reloaded when this occurs so no action is required by software. This flag is informational only and can be used to detect the rate of corruption events. If RAMERROR in ICACHE_IEN is set, an interrupt will be triggered.

The cache is automatically flushed whenever a bus fault occurs. If this occurs during performance counting the counts will be effected.

6.5.2 Performance Measurement

To measure the hit-rate of a code-section, the built-in performance counters can be used. Before the section, start the performance counters by setting STARTPC in ICACHE_CMD register. This starts the performance counters, counting from 0. At the end of the section, stop the performance counters by setting STOPPC in ICACHE_CMD. The number of cache hits and cache misses for that section can then be read from PCHITS and PCMISSES. The cache hit-ratio can be calculated as $PCHITS / (PCHITS + PCMISSES)$. PCAHITS contains the loopcache hits only. Any hits in PCAHITS are also counted in PCHITS. The loopcache hit-ratio can be calculated as $PCAHITS / (PCHITS + PCMISSES)$. When PCHITS/PCAHITS/PCMISSES overflow, the HITOF/AHITOF/MISSOF interrupt flags are set respectively. These flags must be cleared by software. The range of the performance counters can be extended by increasing a counter in the interrupt routine. The performance counters only count when a cache lookup is performed. Access to non-cacheable regions, data fetches, and access made while the ICACHE is disabled do not increment PCMISSES.

Software may check the if the performance counters are running using PCRUNNING in ICACHE_STATUS.

6.5.3 ICACHE Register Map

The offset register address is relative to the registers base address.

Offset	Name	Type	Description
0x000	ICACHE_IPVERSION	R	IP Version
0x004	ICACHE_CTRL	RW	Control Register
0x008	ICACHE_PCHITS	RH	Performance Counter Hits
0x00C	ICACHE_PCMISSES	RH	Performance Counter Misses
0x010	ICACHE_PCAHITS	RH	Performance Counter Advanced Hits
0x014	ICACHE_STATUS	RH	Status Register
0x018	ICACHE_CMD	W	Command Register
0x01C	ICACHE_LPMODE	RW	Low Power Mode
0x020	ICACHE_IF	RWH INTFLAG	Interrupt Flag
0x024	ICACHE_IEN	RW	Interrupt Enable
0x1000	ICACHE_IPVERSION_SET	R	IP Version
0x1004	ICACHE_CTRL_SET	RW	Control Register
0x1008	ICACHE_PCHITS_SET	RH	Performance Counter Hits
0x100C	ICACHE_PCMISSES_SET	RH	Performance Counter Misses
0x1010	ICACHE_PCAHITS_SET	RH	Performance Counter Advanced Hits
0x1014	ICACHE_STATUS_SET	RH	Status Register
0x1018	ICACHE_CMD_SET	W	Command Register
0x101C	ICACHE_LPMODE_SET	RW	Low Power Mode
0x1020	ICACHE_IF_SET	RWH INTFLAG	Interrupt Flag
0x1024	ICACHE_IEN_SET	RW	Interrupt Enable
0x2000	ICACHE_IPVERSION_CLR	R	IP Version
0x2004	ICACHE_CTRL_CLR	RW	Control Register
0x2008	ICACHE_PCHITS_CLR	RH	Performance Counter Hits
0x200C	ICACHE_PCMISSES_CLR	RH	Performance Counter Misses
0x2010	ICACHE_PCAHITS_CLR	RH	Performance Counter Advanced Hits
0x2014	ICACHE_STATUS_CLR	RH	Status Register
0x2018	ICACHE_CMD_CLR	W	Command Register
0x201C	ICACHE_LPMODE_CLR	RW	Low Power Mode
0x2020	ICACHE_IF_CLR	RWH INTFLAG	Interrupt Flag
0x2024	ICACHE_IEN_CLR	RW	Interrupt Enable
0x3000	ICACHE_IPVERSION_TGL	R	IP Version
0x3004	ICACHE_CTRL_TGL	RW	Control Register
0x3008	ICACHE_PCHITS_TGL	RH	Performance Counter Hits
0x300C	ICACHE_PCMISSES_TGL	RH	Performance Counter Misses
0x3010	ICACHE_PCAHITS_TGL	RH	Performance Counter Advanced Hits

Offset	Name	Type	Description
0x3014	ICACHE_STATUS_TGL	RH	Status Register
0x3018	ICACHE_CMD_TGL	W	Command Register
0x301C	ICACHE_LPMODE_TGL	RW	Low Power Mode
0x3020	ICACHE_IF_TGL	RWH INTFLAG	Interrupt Flag
0x3024	ICACHE_IEN_TGL	RW	Interrupt Enable

6.5.4 ICACHE Register Description

6.5.4.1 ICACHE_IPVERSION - IP Version

Offset	Bit Position																															
0x000	31	30	29	28	27	26	25	24	23	22	21	20	19	18	17	16	15	14	13	12	11	10	9	8	7	6	5	4	3	2	1	0
Reset	0x0																															
Access	R																															
Name	IPVERSION																															

Bit	Name	Reset	Access	Description
31:0	IPVERSION	0x0	R	IP version ID The read only IPVERSION field gives the version for this module. There may be minor software changes required for modules with different values of IPVERSION.

6.5.4.2 ICACHE_CTRL - Control Register

Offset	Bit Position																															
0x004	31	30	29	28	27	26	25	24	23	22	21	20	19	18	17	16	15	14	13	12	11	10	9	8	7	6	5	4	3	2	1	0
Reset																	0x0	0x0	0x0													
Access																	RW	RW	RW													
Name																	AUTOFLUSHDIS	USEMPU	CACHEDIS													

Bit	Name	Reset	Access	Description
31:3	<i>Reserved</i>	<i>To ensure compatibility with future devices, always write Reserved bits to their reset value, unless otherwise stated. More information in 1.2 Conventions</i>		
2	AUTOFLUSHDIS	0x0	RW	Automatic Flushing Disable Disables automatic flushing based on Internal Flash write/erase
1	USEMPU	0x0	RW	Use MPU Use MPU to select non/cacheable regions
0	CACHEDIS	0x0	RW	Cache Disable Disables caching for all regions

6.5.4.3 ICACHE_PCHITS - Performance Counter Hits

Offset	Bit Position																															
0x008	31	30	29	28	27	26	25	24	23	22	21	20	19	18	17	16	15	14	13	12	11	10	9	8	7	6	5	4	3	2	1	0
Reset																	0x0															
Access																	R															
Name																	PCHITS															

Bit	Name	Reset	Access	Description
31:0	PCHITS	0x0	R	Performance Counter Hits Hit counter value

6.5.4.4 ICACHE_PCMISSSES - Performance Counter Misses

Offset	Bit Position																															
0x00C	31	30	29	28	27	26	25	24	23	22	21	20	19	18	17	16	15	14	13	12	11	10	9	8	7	6	5	4	3	2	1	0
Reset																0x0																
Access																R																
Name																PCMISSSES																

Bit	Name	Reset	Access	Description
31:0	PCMISSSES	0x0	R	Performance Counter Misses Miss counter value

6.5.4.5 ICACHE_PCAHITS - Performance Counter Advanced Hits

Offset	Bit Position																															
0x010	31	30	29	28	27	26	25	24	23	22	21	20	19	18	17	16	15	14	13	12	11	10	9	8	7	6	5	4	3	2	1	0
Reset																0x0																
Access																R																
Name																PCAHITS																

Bit	Name	Reset	Access	Description
31:0	PCAHITS	0x0	R	Performance Counter Advanced Hits Hit counter value for hits due to Advanced Buffering mode. These hits are also represented in PCHITS.

6.5.4.6 ICACHE_STATUS - Status Register

Offset	Bit Position																															
0x014	31	30	29	28	27	26	25	24	23	22	21	20	19	18	17	16	15	14	13	12	11	10	9	8	7	6	5	4	3	2	1	0
Reset																																0x0
Access																																R
Name																																PCRUNNING

Bit	Name	Reset	Access	Description
31:1	Reserved	To ensure compatibility with future devices, always write Reserved bits to their reset value, unless otherwise stated. More information in 1.2 Conventions		
0	PCRUNNING	0x0	R	PC Running Performance Counters are running

6.5.4.7 ICACHE_CMD - Command Register

Offset	Bit Position																																	
0x018	31	30	29	28	27	26	25	24	23	22	21	20	19	18	17	16	15	14	13	12	11	10	9	8	7	6	5	4	3	2	1	0		
Reset																																0x0	0x0	0x0
Access																																W(nB)	W(nB)	W(nB)
Name																																STOPPC	STARTPC	FLUSH

Bit	Name	Reset	Access	Description
31:3	Reserved	To ensure compatibility with future devices, always write Reserved bits to their reset value, unless otherwise stated. More information in 1.2 Conventions		
2	STOPPC	0x0	W(nB)	Stop Performance Counters Stops the Performance Counters
1	STARTPC	0x0	W(nB)	Start Performance Counters Starts the Performance Counters
0	FLUSH	0x0	W(nB)	Flush Clears Cached Data

6.5.4.8 ICACHE_LPMODE - Low Power Mode

Offset	Bit Position																															
0x01C	31	30	29	28	27	26	25	24	23	22	21	20	19	18	17	16	15	14	13	12	11	10	9	8	7	6	5	4	3	2	1	0
Reset																									0x2						0x3	
Access																									RW						RW	
Name																									NESTFACTOR						LPLEVEL	

Bit	Name	Reset	Access	Description
31:8	<i>Reserved</i>	<i>To ensure compatibility with future devices, always write Reserved bits to their reset value, unless otherwise stated. More information in 1.2 Conventions</i>		
7:4	NESTFACTOR	0x2	RW	Low Power Nest Factor Parameter used in the advanced buffering mode to control its estimation when a branch access is likely to be accessed in the near future. In general, a higher number will improve performance in code with deeply nested loops.
3:2	<i>Reserved</i>	<i>To ensure compatibility with future devices, always write Reserved bits to their reset value, unless otherwise stated. More information in 1.2 Conventions</i>		
1:0	LPLEVEL	0x3	RW	Low Power Level Controls the low-power level of the cache. In general, the default setting is best for most applications.
	Value	Mode	Description	
	0	BASIC	Base instruction cache functionality	
	1	ADVANCED	Advanced buffering mode, where the cache uses the fetch pattern to predict highly accessed data and store it in low-energy memory	
	3	MINACTIVITY	Minimum activity mode, which allows the cache to minimize activity in logic that it predicts has a low probability being used. This mode can introduce wait-states into the instruction fetch stream when the cache exits one of its low-activity states. The number of wait-states introduced is small, but users running with 0-wait-state memory and wishing to reduce the variability that the cache might introduce with additional wait-states may wish to lower the cache low-power level. Note, this mode includes the advanced buffering mode functionality.	

6.5.4.9 ICACHE_IF - Interrupt Flag

Offset	Bit Position																															
0x020	31	30	29	28	27	26	25	24	23	22	21	20	19	18	17	16	15	14	13	12	11	10	9	8	7	6	5	4	3	2	1	0
Reset																								0x0				0x0	0x0	0x0		
Access																								RW								
Name																								RAMERROR				AHITOF	MISSOF	HITOF		

Bit	Name	Reset	Access	Description
31:9	<i>Reserved</i>	<i>To ensure compatibility with future devices, always write Reserved bits to their reset value, unless otherwise stated. More information in 1.2 Conventions</i>		
8	RAMERROR RAM parity error detected	0x0	RW	RAM error Interrupt Flag
7:3	<i>Reserved</i>	<i>To ensure compatibility with future devices, always write Reserved bits to their reset value, unless otherwise stated. More information in 1.2 Conventions</i>		
2	AHITOF Advanced hit performance counter has overflowed	0x0	RW	Advanced Hit Overflow Interrupt Flag
1	MISSOF Miss performance counter has overflowed	0x0	RW	Miss Overflow Interrupt Flag
0	HITOF Hit performance counter has overflowed	0x0	RW	Hit Overflow Interrupt Flag

6.5.4.10 ICACHE_IEN - Interrupt Enable

Offset	Bit Position																															
0x024	31	30	29	28	27	26	25	24	23	22	21	20	19	18	17	16	15	14	13	12	11	10	9	8	7	6	5	4	3	2	1	0
Reset																								0x0				0x0	0x0	0x0		
Access																								RW								
Name																								RAMERROR				AHITOF	MISSOF	HITOF		

Bit	Name	Reset	Access	Description
31:9	Reserved	To ensure compatibility with future devices, always write Reserved bits to their reset value, unless otherwise stated. More information in 1.2 Conventions		
8	RAMERROR Enable RAMERROR interrupt	0x0	RW	RAM error Interrupt Enable
7:3	Reserved	To ensure compatibility with future devices, always write Reserved bits to their reset value, unless otherwise stated. More information in 1.2 Conventions		
2	AHITOF Enable AHITOF interrupt	0x0	RW	Advanced Hit Overflow Interrupt Enable
1	MISSOF Enable MISSOF interrupt	0x0	RW	Miss Overflow Interrupt Enable
0	HITOF Enable HITOF interrupt	0x0	RW	Hit Overflow Interrupt Enable

6.6 SYSCFG - System Configuration

The SYSCFG block is used to configure SRAM. It also contains some interrupt flags for software use. The system has the following major SRAM blocks:

- DMEM0 - Primary system data memory (RAM)
- FRCRAM - Frame Rate Controller SRAM
- SEQRAM - Sequencer SRAM
- DEMODRAM - Demodulator SRAM

6.6.1 RAM Retention

DMEM0 is broken into 16 KB banks. By default all banks are retained in EM2/EM3. Sleep mode current can be significantly reduced by fully powering down banks that do not need to be retained. To select the amount of RAM to be powered down in EM2/EM3, set RAMRETNCTRL in SYSCFG_DMEM0RETNCTRL to the desired value.

FRCRAM and SEQRAM may be powered down in EM2/EM3 if not required. To disable retention, set FRCRAMRETNCTRL or SEQRAMRETNCTRL in SYSCFG_RADIORAMRETNCTRL.

6.6.2 ECC

DMEM0, FRCRAM, and SEQRAM support one bit correction and two bit detection ECC.

To enable error detection for FRCRAM and SEQRAM, set FRCRAMECCCHKEN and SEQRAMECCCHKEN in SYSCFG_RADIO-ECCCTRL. To enable auto-correction of one bit errors in FRCRAM and SEQRAM, set FRCRAMECCCEWEN and SEQRAMECCCEWEN in SYSCFG_RADIOECCCTRL. When ECC error events in FRCRAM and SEQRAM are detected, the corresponding flags in SYSCFG_IF are set. When a flag is set, an interrupt will be triggered if the corresponding interrupt enable bit is set in SYSCFG_IEN. When an error occurs, the address of the detected error is written to SYSCFG_FRCRAMECCADDR or SYSCF_SEQRAMECCERR depending on the source of the error.

To enable error detection for DMEM0, set ECCEN in MPAHBRAM_CTRL. To enable auto-correction of one bit errors in DMEM0, set ECCWEN in MPAHBRAM_CTRL.

When ECC error events in DMEM0 are detected, the corresponding bits in MPAHBRAM_IF are set. Errors arising from a specific port 'x' will be indicated by the AHBxERR1B or AHBxERR2B flags. When a flag is set, an interrupt will be triggered if the corresponding interrupt enable bit is set in MPAHBRAM_IEN. When an error occurs, the address of the detected error is written to MPAHBRAM_EC-CERRADDRx for the respective port 'x'. The address registers are sticky and will not be loaded with a new address until they are cleared through MPAHBRAM_CMD.CLEARECCADDRx. If multiple ECC errors occur without ECCERRADDRn being cleared, the Px bit in MPAHBRAM_ECCMERRIND will be set. These status bits are also sticky, and are cleared with MPAHBRAM_CMD.CLEAREC-CADDRx.

Upon a two bit ECC error in DMEM, MPAHBRAM can also issue a bus fault. To enable this, set the ECCERRFAULTEN bit in MPAHBRAM_CTRL.

The recommend procedure for initializing ECC RAM is to first enable ECC, then write zeros to all locations. This will clear the RAM and initialize the syndrome. If the ECC RAM is not written as described, then any reads to uninitialized RAM locations will result in an ECC error.

Note: The RAM ECC feature must be enabled to achieve good long term reliability. The long term reliability of the RAM is only specified with ECC enabled.

6.6.3 Software Interrupts

The SYSCFG block also provides some software interrupts that can be used to communicate between software tasks. To trigger a software interrupt set the corresponding bit in SYSCFG_IF.

6.6.4 Bus faults

By default, two bit ECC errors and reads to unmapped addresses trigger a BusFault. These bus fault sources can be disabled by clearing RAMECCERRFAULTEN and ADDRFAULTEN in SYSCFG_CTRL.

6.6.5 SYSCFG Register Map

The offset register address is relative to the registers base address.

Offset	Name	Type	Description
0x004	SYSCFG_IPVERSION	R	IP Version ID
0x008	SYSCFG_IF	RWH INTFLAG	Interrupt Flag
0x00C	SYSCFG_IEN	RW	Interrupt Enable
0x014	SYSCFG_CHIPREHVHW	RWH	Chip Revision, Hard-Wired
0x018	SYSCFG_CHIPREV	RW	Part Family and Revision Values
0x024	SYSCFG_CFGSYSTIC	RW	SysTick Clock Source
0x200	SYSCFG_CTRL	RW	Control
0x208	SYSCFG_DMEM0RETNCTRL	RW	DMEM0 Retention Control
0x30C	SYSCFG_RAMBIASCONF	RW	RAM Bias Configuration
0x400	SYSCFG_RADIOGRAM-RETNCTRL	RW	RADIO RAM Retention Control
0x408	SYSCFG_RADIOECCCTRL	RW	RADIO RAM ECC Control Register
0x410	SYSCFG_SEQRAM ECCADDR	RH	SEGRAM ECC Address
0x414	SYSCFG_FRCRAM ECCADDR	RH	FRCRAM ECC Address
0x418	SYSCFG_ICACHERAM-RETNCTRL	RW	HOST ICACHERAM Retention Control
0x41C	SYSCFG_DMEM0PORTMAP-SEL	RW	DMEM0 Port Remap Selection
0x600	SYSCFG_ROOTDATA0	RW	Data Register 0
0x604	SYSCFG_ROOTDATA1	RW	Data Register 1
0x608	SYSCFG_ROOTLOCKSTATUS	RH	Lock Status
0x60C	SYSCFG_ROOTSESWVERSION	RW	SE SW Version
0x1004	SYSCFG_IPVERSION_SET	R	IP Version ID
0x1008	SYSCFG_IF_SET	RWH INTFLAG	Interrupt Flag
0x100C	SYSCFG_IEN_SET	RW	Interrupt Enable
0x1014	SYSCFG_CHIPREHVHW_SET	RWH	Chip Revision, Hard-Wired
0x1018	SYSCFG_CHIPREV_SET	RW	Part Family and Revision Values
0x1024	SYSCFG_CFGSYSTIC_SET	RW	SysTick Clock Source
0x1200	SYSCFG_CTRL_SET	RW	Control
0x1208	SYSCFG_DMEM0RETNCTRL_SET	RW	DMEM0 Retention Control
0x130C	SYSCFG_RAMBIASCONF_SET	RW	RAM Bias Configuration
0x1400	SYSCFG_RADIOGRAM-RETNCTRL_SET	RW	RADIO RAM Retention Control
0x1408	SYSCFG_RADIOECCCTRL_SET	RW	RADIO RAM ECC Control Register

Offset	Name	Type	Description
0x1410	SYSCFG_SEQRAMEC-CADDR_SET	RH	SEQRAM ECC Address
0x1414	SYSCFG_FRCRAMEC-CADDR_SET	RH	FRCRAM ECC Address
0x1418	SYSCFG_ICACHERAM-RETNCTRL_SET	RW	HOST ICACHERAM Retention Control
0x141C	SYSCFG_DMEM0PORTMAP-SEL_SET	RW	DMEM0 Port Remap Selection
0x1600	SYSCFG_ROOTDATA0_SET	RW	Data Register 0
0x1604	SYSCFG_ROOTDATA1_SET	RW	Data Register 1
0x1608	SYSCFG_ROOTLOCKSTATUS_SET	RH	Lock Status
0x160C	SYSCFG_ROOTSESWVERSION_SET	RW	SE SW Version
0x2004	SYSCFG_IPVERSION_CLR	R	IP Version ID
0x2008	SYSCFG_IF_CLR	RWH INTFLAG	Interrupt Flag
0x200C	SYSCFG_IEN_CLR	RW	Interrupt Enable
0x2014	SYSCFG_CHIPRELVHW_CLR	RWH	Chip Revision, Hard-Wired
0x2018	SYSCFG_CHIPREV_CLR	RW	Part Family and Revision Values
0x2024	SYSCFG_CFGSYSTIC_CLR	RW	SysTick Clock Source
0x2200	SYSCFG_CTRL_CLR	RW	Control
0x2208	SYSCFG_DMEM0RETNCTRL_CLR	RW	DMEM0 Retention Control
0x230C	SYSCFG_RAMBIASCONF_CLR	RW	RAM Bias Configuration
0x2400	SYSCFG_RADIOGRAM-RETNCTRL_CLR	RW	RADIO RAM Retention Control
0x2408	SYSCFG_RADIO-ECCCTRL_CLR	RW	RADIO RAM ECC Control Register
0x2410	SYSCFG_SEQRAMEC-CADDR_CLR	RH	SEQRAM ECC Address
0x2414	SYSCFG_FRCRAMEC-CADDR_CLR	RH	FRCRAM ECC Address
0x2418	SYSCFG_ICACHERAM-RETNCTRL_CLR	RW	HOST ICACHERAM Retention Control
0x241C	SYSCFG_DMEM0PORTMAP-SEL_CLR	RW	DMEM0 Port Remap Selection
0x2600	SYSCFG_ROOTDATA0_CLR	RW	Data Register 0
0x2604	SYSCFG_ROOTDATA1_CLR	RW	Data Register 1
0x2608	SYSCFG_ROOTLOCKSTATUS_CLR	RH	Lock Status
0x260C	SYSCFG_ROOTSESWVERSION_CLR	RW	SE SW Version
0x3004	SYSCFG_IPVERSION_TGL	R	IP Version ID

Offset	Name	Type	Description
0x3008	SYSCFG_IF_TGL	RWH INTFLAG	Interrupt Flag
0x300C	SYSCFG_IEN_TGL	RW	Interrupt Enable
0x3014	SYSCFG_CHIPRELVHW_TGL	RWH	Chip Revision, Hard-Wired
0x3018	SYSCFG_CHIPREV_TGL	RW	Part Family and Revision Values
0x3024	SYSCFG_CFGSYSTIC_TGL	RW	SysTick Clock Source
0x3200	SYSCFG_CTRL_TGL	RW	Control
0x3208	SYSCFG_DMEMP0RETNCTRL_TGL	RW	DMEMP0 Retention Control
0x330C	SYSCFG_RAMBIASCONF_TGL	RW	RAM Bias Configuration
0x3400	SYSCFG_RADIO-RAM-RETNCTRL_TGL	RW	RADIO RAM Retention Control
0x3408	SYSCFG_RADIO-ECCCTRL_TGL	RW	RADIO RAM ECC Control Register
0x3410	SYSCFG_SEQRAMEC-CADDR_TGL	RH	SEQRAM ECC Address
0x3414	SYSCFG_FRCRAMEC-CADDR_TGL	RH	FRCRAM ECC Address
0x3418	SYSCFG_ICACHERAM-RETNCTRL_TGL	RW	HOST ICACHERAM Retention Control
0x341C	SYSCFG_DMEMP0PORTMAP-SEL_TGL	RW	DMEMP0 Port Remap Selection
0x3600	SYSCFG_ROOTDATA0_TGL	RW	Data Register 0
0x3604	SYSCFG_ROOTDATA1_TGL	RW	Data Register 1
0x3608	SYSCFG_ROOTLOCKSTATUS_TGL	RH	Lock Status
0x360C	SYSCFG_ROOTSESWVERSION_TGL	RW	SE SW Version

6.6.6 SYSCFG Register Description

6.6.6.1 SYSCFG_IPVERSION - IP Version ID

Offset	Bit Position																															
0x004	31	30	29	28	27	26	25	24	23	22	21	20	19	18	17	16	15	14	13	12	11	10	9	8	7	6	5	4	3	2	1	0
Reset	0x3																															
Access	R																															
Name	IPVERSION																															

Bit	Name	Reset	Access	Description
31:0	IPVERSION	0x3	R	New BitField ID indicating version of IP

6.6.6.2 SYSCFG_IF - Interrupt Flag

Offset	Bit Position																																
0x008	31	30	29	28	27	26	25	24	23	22	21	20	19	18	17	16	15	14	13	12	11	10	9	8	7	6	5	4	3	2	1	0	
Reset			0x0	0x0			0x0	0x0							0x0	0x0				0x0	0x0									0x0	0x0	0x0	0x0
Access			RW	RW			RW	RW							RW	RW				RW	RW	RW	RW	RW	RW					RW	RW	RW	RW
Name			FRCRAMERR2B	FRCRAMERR1B			SEQRAMERR2B	SEQRAMERR1B							SRW2HOSTBUSERR	HOST2SRWBUSERR				FPIXC	FPIDC	FPOFC	FPUFC	FPDZC	FPIOC					SW3	SW2	SW1	SW0

Bit	Name	Reset	Access	Description
31:30	Reserved			To ensure compatibility with future devices, always write Reserved bits to their reset value, unless otherwise stated. More information in 1.2 Conventions
29	FRCRAMERR2B	0x0	RW	FRCRAM Error 2-bit Interrupt Flag FRCRAM 2-bit ECC Error Interrupt flag.
28	FRCRAMERR1B	0x0	RW	FRCRAM Error 1-bit Interrupt Flag FRCRAM 1-bit ECC Error Interrupt flag.
27:26	Reserved			To ensure compatibility with future devices, always write Reserved bits to their reset value, unless otherwise stated. More information in 1.2 Conventions
25	SEQRAMERR2B	0x0	RW	SEQRAM Error 2-bit Interrupt Flag SEQRAM 2-bit ECC Error Interrupt flag.
24	SEQRAMERR1B	0x0	RW	SEQRAM Error 1-bit Interrupt Flag SEQRAM 1-bit ECC Error Interrupt flag.
23:18	Reserved			To ensure compatibility with future devices, always write Reserved bits to their reset value, unless otherwise stated. More information in 1.2 Conventions
17	SRW2HOSTBUSERR	0x0	RW	SRW2HOSTBUSERRIF Interrupt Flag AHB SRW to AHB HOST Bus Error Interrupt Flag
16	HOST2SRWBUSERR	0x0	RW	HOST2SRWBUSERRIF Interrupt Flag AHB Host to AHB SRW Bus Error Interrupt Flag
15:14	Reserved			To ensure compatibility with future devices, always write Reserved bits to their reset value, unless otherwise stated. More information in 1.2 Conventions
13	FPIXC	0x0	RW	FPU Inexact interrupt flag Set upon FPU inexact exception
12	FPIDC	0x0	RW	FPU Input denormal interrupt flag Set upon FPU input denormal exception
11	FPOFC	0x0	RW	FPU Overflow interrupt flag Set upon FPU overflow exception
10	FPUFC	0x0	RW	FPU Underflow interrupt flag

Bit	Name	Reset	Access	Description
				Set upon FPU underflow exception
9	FPDZC	0x0	RW	FPU Divide by zero interrupt flag Set upon FPU divide by zero operation
8	FPIOC	0x0	RW	FPU Invalid Operation interrupt flag Set upon FPU invalid operation
7:4	<i>Reserved</i>	<i>To ensure compatibility with future devices, always write Reserved bits to their reset value, unless otherwise stated. More information in 1.2 Conventions</i>		
3	SW3	0x0	RW	Software Interrupt Flag Software interrupts
2	SW2	0x0	RW	Software Interrupt Flag Software interrupts
1	SW1	0x0	RW	Software Interrupt Flag Software interrupts
0	SW0	0x0	RW	Software Interrupt Flag Software interrupts

6.6.6.3 SYSCFG_IEN - Interrupt Enable

Offset	Bit Position																																		
0x00C	31	30	29	28	27	26	25	24	23	22	21	20	19	18	17	16	15	14	13	12	11	10	9	8	7	6	5	4	3	2	1	0			
Reset			0x0	0x0			0x0	0x0							0x0	0x0				0x0	0x0											0x0	0x0	0x0	0x0
Access			RW	RW			RW	RW							RW	RW				RW	RW	RW	RW	RW	RW							RW	RW	RW	RW
Name			FRCRAMERR2B	FRCRAMERR1B			SEQRAMERR2B	SEQRAMERR1B							SRW2HOSTBUSERR	HOST2SRWBUSERR				FPIXC	FPIDC	FPOFC	FPUFC	FPDZC	FPIOC						SW3	SW2	SW1	SW0	

Bit	Name	Reset	Access	Description
31:30	Reserved			To ensure compatibility with future devices, always write Reserved bits to their reset value, unless otherwise stated. More information in 1.2 Conventions
29	FRCRAMERR2B	0x0	RW	FRCRAM Error 2-bit Interrupt Enable Set to enable the FRCRAM2ERR2BIF Interrupt
28	FRCRAMERR1B	0x0	RW	FRCRAM Error 1-bit Interrupt Enable Set to enable the FRCRAM2ERR1BIF Interrupt
27:26	Reserved			To ensure compatibility with future devices, always write Reserved bits to their reset value, unless otherwise stated. More information in 1.2 Conventions
25	SEQRAMERR2B	0x0	RW	SEQRAM Error 2-bit Interrupt Enable Set to enable the SEQRAM2ERR2BIF Interrupt
24	SEQRAMERR1B	0x0	RW	SEQRAM Error 1-bit Interrupt Enable Set to enable the SEQRAM2ERR1BIF Interrupt
23:18	Reserved			To ensure compatibility with future devices, always write Reserved bits to their reset value, unless otherwise stated. More information in 1.2 Conventions
17	SRW2HOSTBUSERR	0x0	RW	SRW2HOSTBUSERR Interrupt Enable Set to enable the SRW2HOSTBUSERR Interrupt
16	HOST2SRWBUSERR	0x0	RW	HOST2SRWBUSERR Interrupt Enable Set to enable the HOST2SRWBUSERR Interrupt
15:14	Reserved			To ensure compatibility with future devices, always write Reserved bits to their reset value, unless otherwise stated. More information in 1.2 Conventions
13	FPIXC	0x0	RW	FPU Inexact Interrupt Enable Set to enable the FPIXCIF Interrupt
12	FPIDC	0x0	RW	FPU Input denormal Interrupt Enable Set to enable the FPIDCIF Interrupt
11	FPOFC	0x0	RW	FPU Overflow Interrupt Enable Set to enable the FPOFCIF Interrupt
10	FPUFC	0x0	RW	FPU Underflow Interrupt Enable

Bit	Name	Reset	Access	Description
				Set to enable the FPUFCIF Interrupt
9	FPDZC	0x0	RW	FPU Divide by zero Interrupt Enable Set to enable the FPDZCIF Interrupt
8	FPIOC	0x0	RW	FPU Invalid Operation Interrupt Enable Set to enable the FPIOCIF Interrupt
7:4	<i>Reserved</i>	<i>To ensure compatibility with future devices, always write Reserved bits to their reset value, unless otherwise stated. More information in 1.2 Conventions</i>		
3	SW3	0x0	RW	Software Interrupt Enable Set to enable the Software Interrupts
2	SW2	0x0	RW	Software Interrupt Enable Set to enable the Software Interrupts
1	SW1	0x0	RW	Software Interrupt Enable Set to enable the Software Interrupts
0	SW0	0x0	RW	Software Interrupt Enable Set to enable the Software Interrupts

6.6.6.4 SYSCFG_CHIPREVVHW - Chip Revision, Hard-Wired

Offset	Bit Position																															
0x014	31	30	29	28	27	26	25	24	23	22	21	20	19	18	17	16	15	14	13	12	11	10	9	8	7	6	5	4	3	2	1	0
Reset													0x0				0x3C				0x1											
Access													RW				RW				RW											
Name													MINOR				FAMILY				MAJOR											

Bit	Name	Reset	Access	Description
31:20	<i>Reserved</i>	<i>To ensure compatibility with future devices, always write Reserved bits to their reset value, unless otherwise stated. More information in 1.2 Conventions</i>		
19:12	MINOR	0x0	RW	Hardwired Chip Revision Minor value Hardwired Chip Revision Minor signal value
11:6	FAMILY	0x3C	RW	Hardwired Chip Family value Hardwired Chip Family signal value
5:0	MAJOR	0x1	RW	Hardwired Chip Revision Major value Hardwired Chip Revision Major signal value

6.6.6.5 SYSCFG_CHIPREV - Part Family and Revision Values

Offset	Bit Position																															
0x018	31	30	29	28	27	26	25	24	23	22	21	20	19	18	17	16	15	14	13	12	11	10	9	8	7	6	5	4	3	2	1	0
Reset													0x0								0x0								0x0			
Access													RW								RW								RW			
Name													MINOR								FAMILY								MAJOR			

Bit	Name	Reset	Access	Description
31:20	<i>Reserved</i>	<i>To ensure compatibility with future devices, always write Reserved bits to their reset value, unless otherwise stated. More information in 1.2 Conventions</i>		
19:12	MINOR Chip Revision Minor value	0x0	RW	Chip Revision Minor value
11:6	FAMILY Chip Family value	0x0	RW	Chip Family value
	Value	Mode		Description
	60	MG24		Product is in MG24 family
	61	BG24		Product is in BG24 family
5:0	MAJOR Chip Revision Major value	0x0	RW	Chip Revision Major value

6.6.6.6 SYSCFG_CFGSYSTIC - SysTick Clock Source

Offset	Bit Position																															
0x024	31	30	29	28	27	26	25	24	23	22	21	20	19	18	17	16	15	14	13	12	11	10	9	8	7	6	5	4	3	2	1	0
Reset																																0x0
Access																																RW
Name																																SYSTICEXTCKEN

Bit	Name	Reset	Access	Description
31:1	<i>Reserved</i>	<i>To ensure compatibility with future devices, always write Reserved bits to their reset value, unless otherwise stated. More information in 1.2 Conventions</i>		
0	SYSTICEXTCKEN Set 1 to use an external clock as the M33 SysTick.	0x0	RW	SysTick External Clock Enable

6.6.6.7 SYSCFG_CTRL - Control

Offset	Bit Position																															
0x200	31	30	29	28	27	26	25	24	23	22	21	20	19	18	17	16	15	14	13	12	11	10	9	8	7	6	5	4	3	2	1	0
Reset																											0x1				0x1	0x1
Access																											RW				RW	RW
Name																											RAMECCERRFAULTEN				CLKDISFAULTEN	ADDRFAULTEN

Bit	Name	Reset	Access	Description
31:6	Reserved	To ensure compatibility with future devices, always write Reserved bits to their reset value, unless otherwise stated. More information in 1.2 Conventions		
5	RAMECCERRFAULTEN	0x1	RW	Two bit ECC error bus fault response enable When this bit is set, busfaults are generated if 2-bit ECC error occurs.
4:2	Reserved	To ensure compatibility with future devices, always write Reserved bits to their reset value, unless otherwise stated. More information in 1.2 Conventions		
1	CLKDISFAULTEN	0x1	RW	Disabled Clkbus Bus Fault Enable When this bit is set, busfaults are generated on accesses to peripherals with disabled bus clock
0	ADDRFAULTEN	0x1	RW	Invalid Address Bus Fault Response Enable When this bit is set, busfaults are generated on accesses to unmapped parts of system and code address space

6.6.6.8 SYSCFG_DMEMP0RETCTRL - DMEMP0 Retention Control

Offset	Bit Position																															
0x208	31	30	29	28	27	26	25	24	23	22	21	20	19	18	17	16	15	14	13	12	11	10	9	8	7	6	5	4	3	2	1	0
Reset																	0x0															
Access																	RW															
Name																	RAMRETCTRL															

Bit	Name	Reset	Access	Description
31:15	<i>Reserved</i>	<i>To ensure compatibility with future devices, always write Reserved bits to their reset value, unless otherwise stated. More information in 1.2 Conventions</i>		
14:0	RAMRETCTRL	0x0	RW	DMEMP0 blockset retention control DMEMP0 RAM blockset retention controls in EM23 with full access in EM01.
	Value	Mode		Description
	0	ALLON		None of the RAM blocks powered down
	16384	BLK15		Power down RAM block 15 (address range 0x2003C000-0x20040000)
	24576	BLK14TO15		Power down RAM blocks 14 and above (address range 0x20038000-0x20040000)
	28672	BLK13TO15		Power down RAM blocks 13 and above (address range 0x20034000-0x20040000)
	30720	BLK12TO15		Power down RAM blocks 12 and above (address range 0x20030000-0x20040000)
	31744	BLK11TO15		Power down RAM blocks 11 and above (address range 0x2002C000-0x20040000)
	32256	BLK10TO15		Power down RAM blocks 10 and above (address range 0x20028000-0x20040000)
	32512	BLK9TO15		Power down RAM blocks 9 and above (address range 0x20024000-0x20040000)
	32640	BLK8TO15		Power down RAM blocks 8 and above (address range 0x20020000-0x20040000)
	32704	BLK7TO15		Power down RAM blocks 7 and above (address range 0x2001C000-0x20040000)
	32736	BLK6TO15		Power down RAM blocks 6 and above (address range 0x20018000-0x20040000)
	32752	BLK5TO15		Power down RAM blocks 5 and above (address range 0x20014000-0x20040000)
	32760	BLK4TO15		Power down RAM blocks 4 and above (address range 0x20010000-0x20040000)
	32764	BLK3TO15		Power down RAM blocks 3 and above (address range 0x2000C000-0x20040000)

Bit	Name	Reset	Access	Description
32766		BLK2TO15		Power down RAM blocks 2 and above (address range 0x20008000-0x20040000)
32767		BLK1TO15		Power down RAM blocks 1 and above (address range 0x20004000-0x20040000)

6.6.6.9 SYSCFG_RAMBIASCONF - RAM Bias Configuration

Offset	Bit Position																															
0x30C	31	30	29	28	27	26	25	24	23	22	21	20	19	18	17	16	15	14	13	12	11	10	9	8	7	6	5	4	3	2	1	0
Reset																													0x2			
Access																													RW			
Name																													RAMBIASCTRL			

Bit	Name	Reset	Access	Description
31:4	<i>Reserved</i>	<i>To ensure compatibility with future devices, always write Reserved bits to their reset value, unless otherwise stated. More information in 1.2 Conventions</i>		
3:0	RAMBIASCTRL	0x2	RW	RAM Bias Control RAM blockset Bias control. Voltage Source Bias control setting
	Value	Mode		Description
	0	NO		None
	1	VS100		Voltage Source Bias 100mV
	2	VS200		Voltage Source Bias 200mV
	4	VS300		Voltage Source Bias 300mV
	8	VS400		Voltage Source Bias 400mV

6.6.6.10 SYSCFG_RADIORAMRETNCTRL - RADIO RAM Retention Control

Offset	Bit Position																																			
0x400	31	30	29	28	27	26	25	24	23	22	21	20	19	18	17	16	15	14	13	12	11	10	9	8	7	6	5	4	3	2	1	0				
Reset																								0x0												0x0
Access																								RW												RW
Name																								FRCRAMRETNCTRL												SEQRAMRETNCTRL

Bit	Name	Reset	Access	Description
31:9	<i>Reserved</i>	<i>To ensure compatibility with future devices, always write Reserved bits to their reset value, unless otherwise stated. More information in 1.2 Conventions</i>		
8	FRCRAMRETNCTRL	0x0	RW	FRCRAM Retention Control FRC RAM power-down in EM23 with full access in EM01
	Value	Mode		Description
	0	ALLON		FRCRAM not powered down
	1	ALLOFF		Power down FRCRAM
7:2	<i>Reserved</i>	<i>To ensure compatibility with future devices, always write Reserved bits to their reset value, unless otherwise stated. More information in 1.2 Conventions</i>		
1:0	SEQRAMRETNCTRL	0x0	RW	SEQRAM Retention Control SEQUENCER RAM power-down in EM23 with full access in EM01
	Value	Mode		Description
	0	ALLON		SEQRAM not powered down
	1	BLK0		Power down SEQRAM block 0
	2	BLK1		Power down SEQRAM block 1
	3	ALLOFF		Power down all SEQRAM blocks

6.6.6.11 SYSCFG_RADIOECCCTRL - RADIO RAM ECC Control Register

Offset	Bit Position																																							
0x408	31	30	29	28	27	26	25	24	23	22	21	20	19	18	17	16	15	14	13	12	11	10	9	8	7	6	5	4	3	2	1	0								
Reset																							0x0	0x0															0x0	0x0
Access																							RW	RW															RW	RW
Name																							FRCRAMECCEWEN	FRCRAMECCEN															SEQRAMECCEWEN	SEQRAMECCEN

Bit	Name	Reset	Access	Description
31:10	<i>Reserved</i>	<i>To ensure compatibility with future devices, always write Reserved bits to their reset value, unless otherwise stated. More information in 1.2 Conventions</i>		
9	FRCRAMECCEWEN	0x0	RW	FRCRAM ECC Error Writeback Enable FRC ECC Error Writeback Enable. When set, errors will be corrected when encountered.
8	FRCRAMECCEN	0x0	RW	FRCRAM ECC Enable FRCRAM ECC Enable.
7:2	<i>Reserved</i>	<i>To ensure compatibility with future devices, always write Reserved bits to their reset value, unless otherwise stated. More information in 1.2 Conventions</i>		
1	SEQRAMECCEWEN	0x0	RW	SEQRAM ECC Error Writeback Enable SEQRAM ECC Error Writeback Enable. When set, errors will be corrected when encountered.
0	SEQRAMECCEN	0x0	RW	SEQRAM ECC Enable SEQRAM ECC Enable.

6.6.6.12 SYSCFG_SEQRAMECCADDR - SEQRAM ECC Address

Offset	Bit Position																															
0x410	31	30	29	28	27	26	25	24	23	22	21	20	19	18	17	16	15	14	13	12	11	10	9	8	7	6	5	4	3	2	1	0
Reset	0x0																															
Access	R																															
Name	SEQRAMECCADDR																															

Bit	Name	Reset	Access	Description
31:0	SEQRAMECCADDR	0x0	R	SEQRAM ECC Address Indicates Address of SEQRAM at which ECC error occurred

6.6.6.13 SYSCFG_FRCRAMECCADDR - FRCRAM ECC Address

Offset	Bit Position																															
0x414	31	30	29	28	27	26	25	24	23	22	21	20	19	18	17	16	15	14	13	12	11	10	9	8	7	6	5	4	3	2	1	0
Reset	0x0																															
Access	R																															
Name	FRCRAMECCADDR																															

Bit	Name	Reset	Access	Description
31:0	FRCRAMECCADDR	0x0	R	FRCRAM ECC Error Address Indicates Address of FRCRAM at which ECC error occurred

6.6.6.14 SYSCFG_ICACHERAMRETCTRL - HOST ICACHERAM Retention Control

Offset	Bit Position																															
0x418	31	30	29	28	27	26	25	24	23	22	21	20	19	18	17	16	15	14	13	12	11	10	9	8	7	6	5	4	3	2	1	0
Reset																												0x0				
Access																												RW				
Name																												RAMRETCTRL				

Bit	Name	Reset	Access	Description
31:1	<i>Reserved</i>	<i>To ensure compatibility with future devices, always write Reserved bits to their reset value, unless otherwise stated. More information in 1.2 Conventions</i>		
0	RAMRETCTRL	0x0	RW	ICACHERAM Retention control Host ICACHE RAM power-down in EM23 with full access in EM01.
	Value	Mode		Description
	0	ALLON		None of the Host ICACHE RAM blocks powered down
	1	ALLOFF		Power down all Host ICACHE RAM blocks

6.6.6.15 SYSCFG_DMEMP0PORTMAPSEL - DMEMP0 Port Remap Selection

Offset	Bit Position																															
0x41C	31	30	29	28	27	26	25	24	23	22	21	20	19	18	17	16	15	14	13	12	11	10	9	8	7	6	5	4	3	2	1	0
Reset																	0x1	0x3	0x2	0x1	0x0	0x0	0x1	0x1	0x1	0x1						
Access																	RW	RW	RW	RW	RW	RW	RW	RW	RW	RW						
Name																	MVPAHBDATA2PORTSEL	MVPAHBDATA1PORTSEL	MVPAHBDATA0PORTSEL	SRWECA1PORTSEL	SRWECA0PORTSEL	AHBSRWPORTSEL	SRWAESPORTSEL	LDMAPORTSEL								

Bit	Name	Reset	Access	Description
31:16	Reserved	To ensure compatibility with future devices, always write Reserved bits to their reset value, unless otherwise stated. More information in 1.2 Conventions		
15:14	MVPAHBDATA2PORTSEL	0x1	RW	MVPAHBDATA2 portmap selection MVPWDMA address remap selection, default configured to MPAHBRAM1
13:12	MVPAHBDATA1PORTSEL	0x3	RW	MVPAHBDATA1 portmap selection MVPRDMA1 address remap selection, default configured to MPAHBRAM3
11:10	MVPAHBDATA0PORTSEL	0x2	RW	MVPAHBDATA0 portmap selection MVPRDMA0 address remap selection, default configured to MPAHBRAM2
9:8	SRWECA1PORTSEL	0x1	RW	SRWECA1 portmap selection SRWECA1 address remap selection, default configured to MPAHBRAM1
7:6	SRWECA0PORTSEL	0x0	RW	SRWECA0 portmap selection SRWECA0 address remap selection, default configured to MPAHBRAM0
5:4	AHBSRWPORTSEL	0x0	RW	AHBSRW portmap selection AHBSRW address remap selection, default configured to MPAHBRAM0
3:2	SRWAESPORTSEL	0x1	RW	SRWAES portmap selection SRWAES address remap selection, default configured to MPAHBRAM1
1:0	LDMAPORTSEL	0x1	RW	LDMA portmap selection LDMA address remap selection, default configured to MPAHBRAM1

6.6.6.16 SYSCFG_ROOTDATA0 - Data Register 0

Offset	Bit Position																															
0x600	31	30	29	28	27	26	25	24	23	22	21	20	19	18	17	16	15	14	13	12	11	10	9	8	7	6	5	4	3	2	1	0
Reset	0x0																															
Access	RW																															
Name	DATA																															

Bit	Name	Reset	Access	Description
31:0	DATA	0x0	RW	Data Generic data space for user to pass to root, e.g., address of struct in mem

6.6.6.17 SYSCFG_ROOTDATA1 - Data Register 1

Offset	Bit Position																															
0x604	31	30	29	28	27	26	25	24	23	22	21	20	19	18	17	16	15	14	13	12	11	10	9	8	7	6	5	4	3	2	1	0
Reset	0x0																															
Access	RW																															
Name	DATA																															

Bit	Name	Reset	Access	Description
31:0	DATA	0x0	RW	Data Generic data space for user to pass to root, e.g., address of struct in mem

6.6.6.18 SYSCFG_ROOTLOCKSTATUS - Lock Status

Offset	Bit Position																																
0x608	31	30	29	28	27	26	25	24	23	22	21	20	19	18	17	16	15	14	13	12	11	10	9	8	7	6	5	4	3	2	1	0	
Reset	0x0									0x1	0x1	0x1	0x1	0x1	0x1	0x1								0x1							0x1	0x1	0x1
Access	R									R	R	R	R	R	R	R								R							R	R	R
Name	EFUSEUNLOCKED									RADIONIDBGLOCK	RADIOIDBGLOCK	USERSPNIDLOCK	USERSPIDLOCK	USERNIDLOCK	USERDBGLOCK	USERDBGAPLOCK								ROOTDBGLOCK							MFRLOCK	REGLOCK	BUSLOCK

Bit	Name	Reset	Access	Description
31	EFUSEUNLOCKED	0x0	R	E-Fuse Unlocked E-Fuse Unlocked when 1; Locked when 0.
30:23	<i>Reserved</i>	<i>To ensure compatibility with future devices, always write Reserved bits to their reset value, unless otherwise stated. More information in 1.2 Conventions</i>		
22	RADIONIDBGLOCK	0x1	R	Radio Non-invasive Debug Lock Locked when 1; unlocked when 0.
21	RADIOIDBGLOCK	0x1	R	Radio Invasive Debug Lock Locked when 1; unlocked when 0.
20	USERSPNIDLOCK	0x1	R	User Secure Non-invasive Debug Lock Locked when 1; unlocked when 0.
19	USERSPIDLOCK	0x1	R	User Secure Invasive Debug Lock Locked when 1; unlocked when 0.
18	USERNIDLOCK	0x1	R	User Non-invasive Debug Lock Locked when 1; unlocked when 0.
17	USERDBGLOCK	0x1	R	User Invasive Debug Lock Locked when 1; unlocked when 0.
16	USERDBGAPLOCK	0x1	R	User Debug Access Port Lock Locked when 1; unlocked when 0.
15:9	<i>Reserved</i>	<i>To ensure compatibility with future devices, always write Reserved bits to their reset value, unless otherwise stated. More information in 1.2 Conventions</i>		
8	ROOTDBGLOCK	0x1	R	Root Debug Lock Locked when 1; unlocked when 0.
7:3	<i>Reserved</i>	<i>To ensure compatibility with future devices, always write Reserved bits to their reset value, unless otherwise stated. More information in 1.2 Conventions</i>		
2	MFRLOCK	0x1	R	Manufacture Lock Locked when 1; unlocked when 0.
1	REGLOCK	0x1	R	Register Lock

Bit	Name	Reset	Access	Description
				Locked when 1; unlocked when 0.
0	BUSLOCK	0x1	R	Bus Lock Locked when 1; unlocked when 0.

6.6.6.19 SYSCFG_ROOTSESWVERSION - SE SW Version

Offset	Bit Position																															
0x60C	31	30	29	28	27	26	25	24	23	22	21	20	19	18	17	16	15	14	13	12	11	10	9	8	7	6	5	4	3	2	1	0
Reset	0x0																															
Access	RW																															
Name	SWVERSION																															

Bit	Name	Reset	Access	Description
31:0	SWVERSION	0x0	RW	SW Version Location for SE to write the Firmware version and host to read it

6.6.7 MPAHBRAM Register Map

The offset register address is relative to the registers base address.

Offset	Name	Type	Description
0x000	MPAHBRAM_IPVERSION	R	IP Version ID
0x004	MPAHBRAM_CMD	W	Command Register
0x008	MPAHBRAM_CTRL	RW	Control Register
0x00C	MPAHBRAM_ECCERRADDR0	RH	ECC Error Address 0
0x010	MPAHBRAM_ECCERRADDR1	RH	ECC Error Address 1
0x014	MPAHBRAM_ECCERRADDR2	RH	ECC Error Address 2
0x018	MPAHBRAM_ECCERRADDR3	RH	ECC Error Address 3
0x01C	MPAHBRAM_ECCMERRIND	RH	Multiple ECC Error Indication
0x020	MPAHBRAM_IF	RWH INTFLAG	Interrupt Flags
0x024	MPAHBRAM_IEN	RW	Interrupt Enable
0x1000	MPAHBRAM_IPVERSION_SET	R	IP Version ID
0x1004	MPAHBRAM_CMD_SET	W	Command Register
0x1008	MPAHBRAM_CTRL_SET	RW	Control Register
0x100C	MPAHBRAM_ECCERRADDR0_SET	RH	ECC Error Address 0
0x1010	MPAHBRAM_ECCERRADDR1_SET	RH	ECC Error Address 1
0x1014	MPAHBRAM_ECCERRADDR2_SET	RH	ECC Error Address 2
0x1018	MPAHBRAM_ECCERRADDR3_SET	RH	ECC Error Address 3
0x101C	MPAHBRAM_ECCMERRIND_SET	RH	Multiple ECC Error Indication
0x1020	MPAHBRAM_IF_SET	RWH INTFLAG	Interrupt Flags
0x1024	MPAHBRAM_IEN_SET	RW	Interrupt Enable
0x2000	MPAHBRAM_IPVERSION_CLR	R	IP Version ID
0x2004	MPAHBRAM_CMD_CLR	W	Command Register
0x2008	MPAHBRAM_CTRL_CLR	RW	Control Register
0x200C	MPAHBRAM_ECCERRADDR0_CLR	RH	ECC Error Address 0
0x2010	MPAHBRAM_ECCERRADDR1_CLR	RH	ECC Error Address 1
0x2014	MPAHBRAM_ECCERRADDR2_CLR	RH	ECC Error Address 2
0x2018	MPAHBRAM_ECCERRADDR3_CLR	RH	ECC Error Address 3
0x201C	MPAHBRAM_ECCMERRIND_CLR	RH	Multiple ECC Error Indication
0x2020	MPAHBRAM_IF_CLR	RWH INTFLAG	Interrupt Flags

Offset	Name	Type	Description
0x2024	MPAHBRAM_IEN_CLR	RW	Interrupt Enable
0x3000	MPAHBRAM_IPVERSION_TGL	R	IP Version ID
0x3004	MPAHBRAM_CMD_TGL	W	Command Register
0x3008	MPAHBRAM_CTRL_TGL	RW	Control Register
0x300C	MPAHBRAM_ECCER-RADDR0_TGL	RH	ECC Error Address 0
0x3010	MPAHBRAM_ECCER-RADDR1_TGL	RH	ECC Error Address 1
0x3014	MPAHBRAM_ECCER-RADDR2_TGL	RH	ECC Error Address 2
0x3018	MPAHBRAM_ECCER-RADDR3_TGL	RH	ECC Error Address 3
0x301C	MPAHBRAM_ECCMER-RIND_TGL	RH	Multiple ECC Error Indication
0x3020	MPAHBRAM_IF_TGL	RWH INTFLAG	Interrupt Flags
0x3024	MPAHBRAM_IEN_TGL	RW	Interrupt Enable

6.6.8 MPAHBRAM Register Description

6.6.8.1 MPAHBRAM_IPVERSION - IP Version ID

Offset	Bit Position																																	
	31	30	29	28	27	26	25	24	23	22	21	20	19	18	17	16	15	14	13	12	11	10	9	8	7	6	5	4	3	2	1	0		
0x000																																		
Reset																															1	0x2		
Access																																R		
Name																																IPVERSION		

Bit	Name	Reset	Access	Description
31:2	<i>Reserved</i>	<i>To ensure compatibility with future devices, always write Reserved bits to their reset value, unless otherwise stated. More information in 1.2 Conventions</i>		
1:0	IPVERSION	0x2	R	New BitField

6.6.8.2 MPAHBRAM_CMD - Command Register

Offset	Bit Position																															
0x004	31	30	29	28	27	26	25	24	23	22	21	20	19	18	17	16	15	14	13	12	11	10	9	8	7	6	5	4	3	2	1	0
Reset																											0x0	0x0	0x0	0x0		
Access																											W(nB)	W(nB)	W(nB)	W(nB)		
Name																											CLEARECCADDR3	CLEARECCADDR2	CLEARECCADDR1	CLEARECCADDR0		

Bit	Name	Reset	Access	Description
31:4	<i>Reserved</i>	<i>To ensure compatibility with future devices, always write Reserved bits to their reset value, unless otherwise stated. More information in 1.2 Conventions</i>		
3	CLEARECCADDR3	0x0	W(nB)	Clear ECCERRADDR3 Write 1 to clear ECCERRADDR3 and ECCMERRIND.P3.
2	CLEARECCADDR2	0x0	W(nB)	Clear ECCERRADDR2 Write 1 to clear ECCERRADDR2 and ECCMERRIND.P2.
1	CLEARECCADDR1	0x0	W(nB)	Clear ECCERRADDR1 Write 1 to clear ECCERRADDR1 and ECCMERRIND.P1.
0	CLEARECCADDR0	0x0	W(nB)	Clear ECCERRADDR0 Write 1 to clear ECCERRADDR0 and ECCMERRIND.P0.

6.6.8.3 MPAHBRAM_CTRL - Control Register

Offset	Bit Position																																																					
0x008	31	30	29	28	27	26	25	24	23	22	21	20	19	18	17	16	15	14	13	12	11	10	9	8	7	6	5	4	3	2	1	0																						
Reset																									0x0	0x1		0x0		0x0		0x0		0x0		0x0		0x0		0x0		0x0		0x0		0x0		0x0		0x0		0x0		0x0
Access																									RW	RW		RW		RW		RW		RW		RW		RW		RW		RW		RW		RW		RW		RW		RW		RW
Name																									WAITSTATES	ADDRFAULTEN		AHBPORTPRIORITY		ECCERRFAULTEN		ECCWEN		ECCEN																				

Bit	Name	Reset	Access	Description
31:8	Reserved	To ensure compatibility with future devices, always write Reserved bits to their reset value, unless otherwise stated. More information in 1.2 Conventions		
7	WAITSTATES	0x0	RW	RAM read wait states Configure the number of wait states upon RAM read access. Must be set to 1 if the clock frequency is above N MHz.
6	ADDRFAULTEN	0x1	RW	Address fault bus fault enable Enable bus fault upon address fault
5:3	AHBPORTPRIORITY	0x0	RW	AHB port arbitration priority
	Value	Mode		Description
	0	NONE		No AHB port have raised priority.
	1	PORT0		AHB port 0 has raised priority.
	2	PORT1		AHB port 1 has raised priority.
	3	PORT2		AHB port 2 has raised priority.
	4	PORT3		AHB port 3 has raised priority.
2	ECCERRFAULTEN	0x0	RW	ECC Error bus fault enable Enable bus fault upon 2 bit ECC error
1	ECCWEN	0x0	RW	Enable ECC syndrome writes
0	ECCEN	0x0	RW	Enable ECC functionality

6.6.8.4 MPAHBRAM_ECCERRADDR0 - ECC Error Address 0

Offset	Bit Position																															
0x00C	31	30	29	28	27	26	25	24	23	22	21	20	19	18	17	16	15	14	13	12	11	10	9	8	7	6	5	4	3	2	1	0
Reset																0x0																
Access																R																
Name																ADDR																

Bit	Name	Reset	Access	Description
31:0	ADDR	0x0	R	ECC Error Address Last captured ECC error address on AHB port 0. Cleared by CMD.CLEARECCADDR0

6.6.8.5 MPAHBRAM_ECCERRADDR1 - ECC Error Address 1

Offset	Bit Position																															
0x010	31	30	29	28	27	26	25	24	23	22	21	20	19	18	17	16	15	14	13	12	11	10	9	8	7	6	5	4	3	2	1	0
Reset																0x0																
Access																R																
Name																ADDR																

Bit	Name	Reset	Access	Description
31:0	ADDR	0x0	R	ECC Error Address Last captured ECC error address on AHB port 1. Cleared by CMD.CLEARECCADDR1

6.6.8.6 MPAHBRAM_ECCERRADDR2 - ECC Error Address 2

Offset	Bit Position																															
0x014	31	30	29	28	27	26	25	24	23	22	21	20	19	18	17	16	15	14	13	12	11	10	9	8	7	6	5	4	3	2	1	0
Reset																0x0																
Access																R																
Name																ADDR																

Bit	Name	Reset	Access	Description
31:0	ADDR	0x0	R	ECC Error Address Last captured ECC error address on AHB port 2. Cleared by CMD.CLEARECCADDR2

6.6.8.7 MPAHBRAM_ECCERRADDR3 - ECC Error Address 3

Offset	Bit Position																															
0x018	31	30	29	28	27	26	25	24	23	22	21	20	19	18	17	16	15	14	13	12	11	10	9	8	7	6	5	4	3	2	1	0
Reset																0x0																
Access																R																
Name																ADDR																

Bit	Name	Reset	Access	Description
31:0	ADDR	0x0	R	ECC Error Address Last captured ECC error address on AHB port 3. Cleared by CMD.CLEARECCADDR3

6.6.8.8 MPAHBRAM_ECCMERRIND - Multiple ECC Error Indication

Offset	Bit Position																															
0x01C	31	30	29	28	27	26	25	24	23	22	21	20	19	18	17	16	15	14	13	12	11	10	9	8	7	6	5	4	3	2	1	0
Reset																												0x0	0x0	0x0	0x0	
Access																												R	R	R	R	
Name																												P3	P2	P1	P0	

Bit	Name	Reset	Access	Description
31:4	<i>Reserved</i>	<i>To ensure compatibility with future devices, always write Reserved bits to their reset value, unless otherwise stated. More information in 1.2 Conventions</i>		
3	P3	0x0	R	Multiple ECC errors on AHB port 2 Multiple ECC error indication on AHB port 3. Cleared by CMD.CLEARECCADDR3.
2	P2	0x0	R	Multiple ECC errors on AHB port 2 Multiple ECC error indication on AHB port 2. Cleared by CMD.CLEARECCADDR2.
1	P1	0x0	R	Multiple ECC errors on AHB port 1 Multiple ECC error indication on AHB port 1. Cleared by CMD.CLEARECCADDR1.
0	P0	0x0	R	Multiple ECC errors on AHB port 0 Multiple ECC error indication on AHB port 0. Cleared by CMD.CLEARECCADDR0.

6.6.8.9 MPAHBRAM_IF - Interrupt Flags

Offset	Bit Position																																																							
0x020	31	30	29	28	27	26	25	24	23	22	21	20	19	18	17	16	15	14	13	12	11	10	9	8	7	6	5	4	3	2	1	0																								
Reset																									0x0	0x0	0x0	0x0	0x0	0x0	0x0	0x0	0x0	0x0	0x0	0x0	0x0	0x0	0x0	0x0	0x0	0x0	0x0	0x0	0x0	0x0	0x0	0x0	0x0	0x0	0x0	0x0	0x0	0x0		
Access																									RW	RW	RW	RW	RW	RW	RW	RW	RW	RW	RW	RW	RW	RW	RW	RW	RW	RW	RW	RW	RW	RW	RW	RW	RW	RW	RW	RW	RW	RW	RW	
Name																									AHB3ERR2B	AHB2ERR2B	AHB1ERR2B	AHB0ERR2B	AHB3ERR1B	AHB2ERR1B	AHB1ERR1B	AHB0ERR1B	AHB3ERR1B	AHB2ERR1B	AHB1ERR1B	AHB0ERR1B	AHB3ERR1B	AHB2ERR1B	AHB1ERR1B	AHB0ERR1B	AHB3ERR1B	AHB2ERR1B	AHB1ERR1B	AHB0ERR1B	AHB3ERR1B	AHB2ERR1B	AHB1ERR1B	AHB0ERR1B	AHB3ERR1B	AHB2ERR1B	AHB1ERR1B	AHB0ERR1B	AHB3ERR1B	AHB2ERR1B	AHB1ERR1B	AHB0ERR1B

Bit	Name	Reset	Access	Description
31:8	<i>Reserved</i>	<i>To ensure compatibility with future devices, always write Reserved bits to their reset value, unless otherwise stated. More information in 1.2 Conventions</i>		
7	AHB3ERR2B	0x0	RW	AHB3 2-bit ECC Error Interrupt Flag
6	AHB2ERR2B	0x0	RW	AHB2 2-bit ECC Error Interrupt Flag
5	AHB1ERR2B	0x0	RW	AHB1 2-bit ECC Error Interrupt Flag
4	AHB0ERR2B	0x0	RW	AHB0 2-bit ECC Error Interrupt Flag
3	AHB3ERR1B	0x0	RW	AHB3 1-bit ECC Error Interrupt Flag
2	AHB2ERR1B	0x0	RW	AHB2 1-bit ECC Error Interrupt Flag
1	AHB1ERR1B	0x0	RW	AHB1 1-bit ECC Error Interrupt Flag
0	AHB0ERR1B	0x0	RW	AHB0 1-bit ECC Error Interrupt Flag

6.6.8.10 MPAHBRAM_IEN - Interrupt Enable

Offset	Bit Position																																																							
0x024	31	30	29	28	27	26	25	24	23	22	21	20	19	18	17	16	15	14	13	12	11	10	9	8	7	6	5	4	3	2	1	0																								
Reset																									0x0	0x0	0x0	0x0	0x0	0x0	0x0	0x0	0x0	0x0	0x0	0x0	0x0	0x0	0x0	0x0	0x0	0x0	0x0	0x0	0x0	0x0	0x0	0x0	0x0	0x0	0x0	0x0	0x0	0x0		
Access																									RW	RW	RW	RW	RW	RW	RW	RW	RW	RW	RW	RW	RW	RW	RW	RW	RW	RW	RW	RW	RW	RW	RW	RW	RW	RW	RW	RW	RW	RW	RW	
Name																									AHB3ERR2B	AHB2ERR2B	AHB1ERR2B	AHB0ERR2B	AHB3ERR1B	AHB2ERR1B	AHB1ERR1B	AHB0ERR1B	AHB3ERR1B	AHB2ERR1B	AHB1ERR1B	AHB0ERR1B	AHB3ERR1B	AHB2ERR1B	AHB1ERR1B	AHB0ERR1B	AHB3ERR1B	AHB2ERR1B	AHB1ERR1B	AHB0ERR1B	AHB3ERR1B	AHB2ERR1B	AHB1ERR1B	AHB0ERR1B	AHB3ERR1B	AHB2ERR1B	AHB1ERR1B	AHB0ERR1B	AHB3ERR1B	AHB2ERR1B	AHB1ERR1B	AHB0ERR1B

Bit	Name	Reset	Access	Description
31:8	<i>Reserved</i>	<i>To ensure compatibility with future devices, always write Reserved bits to their reset value, unless otherwise stated. More information in 1.2 Conventions</i>		
7	AHB3ERR2B	0x0	RW	AHB3 2-bit ECC Error Interrupt Enable
6	AHB2ERR2B	0x0	RW	AHB2 2-bit ECC Error Interrupt Enable
5	AHB1ERR2B	0x0	RW	AHB1 2-bit ECC Error Interrupt Enable
4	AHB0ERR2B	0x0	RW	AHB0 2-bit ECC Error Interrupt Enable
3	AHB3ERR1B	0x0	RW	AHB3 1-bit ECC Error Interrupt Enable
2	AHB2ERR1B	0x0	RW	AHB2 1-bit ECC Error Interrupt Enable
1	AHB1ERR1B	0x0	RW	AHB1 1-bit ECC Error Interrupt Enable
0	AHB0ERR1B	0x0	RW	AHB0 1-bit ECC Error Interrupt Enable

6.7 MSC Register Map

The offset register address is relative to the registers base address.

Offset	Name	Type	Description
0x000	MSC_IPVERSION	R	IP Version ID
0x004	MSC_READCTRL	RW	Read Control Register
0x008	MSC_RDATACTRL	RW	Read Data Control Register
0x00C	MSC_WRITECTRL	RW	Write Control Register
0x010	MSC_WRITECMD	W	Write Command Register
0x014	MSC_ADDRB	RWH	Page Erase/Write Address Buffer
0x018	MSC_WDATA	RWH	Write Data Register
0x01C	MSC_STATUS	RH	Status Register
0x020	MSC_IF	RWH	Interrupt Flag Register
0x024	MSC_IEN	RW	Interrupt Enable Register
0x034	MSC_USERDATASIZE	R	User Data Region Size Register
0x038	MSC_CMD	W	Command Register
0x03C	MSC_LOCK	W	Configuration Lock Register
0x040	MSC_MISCLOCKWORD	RW	Mass Erase and User Data Page Lock Word
0x050	MSC_PWRCTRL	RW	Power Control Register
0x120	MSC_PAGELOCK0	RW	Main Space Page 0-31 Lock Word
0x124	MSC_PAGELOCK1	RW	Main Space Page 32-63 Lock Word
0x128	MSC_PAGELOCK2	RW	Main Space Page 64-95 Lock Word
0x12C	MSC_PAGELOCK3	RW	Main Space Page 96-127 Lock Word
0x130	MSC_PAGELOCK4	RW	Main Space Page 128-159 Lock Word
0x134	MSC_PAGELOCK5	RW	Main Space Page 160-191 Lock Word
0x1000	MSC_IPVERSION_SET	R	IP Version ID
0x1004	MSC_READCTRL_SET	RW	Read Control Register
0x1008	MSC_RDATACTRL_SET	RW	Read Data Control Register
0x100C	MSC_WRITECTRL_SET	RW	Write Control Register
0x1010	MSC_WRITECMD_SET	W	Write Command Register
0x1014	MSC_ADDRB_SET	RWH	Page Erase/Write Address Buffer
0x1018	MSC_WDATA_SET	RWH	Write Data Register
0x101C	MSC_STATUS_SET	RH	Status Register
0x1020	MSC_IF_SET	RWH	Interrupt Flag Register
0x1024	MSC_IEN_SET	RW	Interrupt Enable Register
0x1034	MSC_USERDATASIZE_SET	R	User Data Region Size Register
0x1038	MSC_CMD_SET	W	Command Register
0x103C	MSC_LOCK_SET	W	Configuration Lock Register
0x1040	MSC_MISCLOCKWORD_SET	RW	Mass Erase and User Data Page Lock Word

Offset	Name	Type	Description
0x1050	MSC_PWRCTRL_SET	RW	Power Control Register
0x1120	MSC_PAGELOCK0_SET	RW	Main Space Page 0-31 Lock Word
0x1124	MSC_PAGELOCK1_SET	RW	Main Space Page 32-63 Lock Word
0x1128	MSC_PAGELOCK2_SET	RW	Main Space Page 64-95 Lock Word
0x112C	MSC_PAGELOCK3_SET	RW	Main Space Page 96-127 Lock Word
0x1130	MSC_PAGELOCK4_SET	RW	Main Space Page 128-159 Lock Word
0x1134	MSC_PAGELOCK5_SET	RW	Main Space Page 160-191 Lock Word
0x2000	MSC_IPVERSION_CLR	R	IP Version ID
0x2004	MSC_READCTRL_CLR	RW	Read Control Register
0x2008	MSC_RDATACTRL_CLR	RW	Read Data Control Register
0x200C	MSC_WRITECTRL_CLR	RW	Write Control Register
0x2010	MSC_WRITECMD_CLR	W	Write Command Register
0x2014	MSC_ADDRB_CLR	RWH	Page Erase/Write Address Buffer
0x2018	MSC_WDATA_CLR	RWH	Write Data Register
0x201C	MSC_STATUS_CLR	RH	Status Register
0x2020	MSC_IF_CLR	RWH	Interrupt Flag Register
0x2024	MSC_IEN_CLR	RW	Interrupt Enable Register
0x2034	MSC_USERDATASIZE_CLR	R	User Data Region Size Register
0x2038	MSC_CMD_CLR	W	Command Register
0x203C	MSC_LOCK_CLR	W	Configuration Lock Register
0x2040	MSC_MISLOCKWORD_CLR	RW	Mass Erase and User Data Page Lock Word
0x2050	MSC_PWRCTRL_CLR	RW	Power Control Register
0x2120	MSC_PAGELOCK0_CLR	RW	Main Space Page 0-31 Lock Word
0x2124	MSC_PAGELOCK1_CLR	RW	Main Space Page 32-63 Lock Word
0x2128	MSC_PAGELOCK2_CLR	RW	Main Space Page 64-95 Lock Word
0x212C	MSC_PAGELOCK3_CLR	RW	Main Space Page 96-127 Lock Word
0x2130	MSC_PAGELOCK4_CLR	RW	Main Space Page 128-159 Lock Word
0x2134	MSC_PAGELOCK5_CLR	RW	Main Space Page 160-191 Lock Word
0x3000	MSC_IPVERSION_TGL	R	IP Version ID
0x3004	MSC_READCTRL_TGL	RW	Read Control Register
0x3008	MSC_RDATACTRL_TGL	RW	Read Data Control Register
0x300C	MSC_WRITECTRL_TGL	RW	Write Control Register
0x3010	MSC_WRITECMD_TGL	W	Write Command Register
0x3014	MSC_ADDRB_TGL	RWH	Page Erase/Write Address Buffer
0x3018	MSC_WDATA_TGL	RWH	Write Data Register
0x301C	MSC_STATUS_TGL	RH	Status Register
0x3020	MSC_IF_TGL	RWH	Interrupt Flag Register

Offset	Name	Type	Description
0x3024	MSC_IEN_TGL	RW	Interrupt Enable Register
0x3034	MSC_USERDATASIZE_TGL	R	User Data Region Size Register
0x3038	MSC_CMD_TGL	W	Command Register
0x303C	MSC_LOCK_TGL	W	Configuration Lock Register
0x3040	MSC_MISLOCKWORD_TGL	RW	Mass Erase and User Data Page Lock Word
0x3050	MSC_PWRCTRL_TGL	RW	Power Control Register
0x3120	MSC_PAGELOCK0_TGL	RW	Main Space Page 0-31 Lock Word
0x3124	MSC_PAGELOCK1_TGL	RW	Main Space Page 32-63 Lock Word
0x3128	MSC_PAGELOCK2_TGL	RW	Main Space Page 64-95 Lock Word
0x312C	MSC_PAGELOCK3_TGL	RW	Main Space Page 96-127 Lock Word
0x3130	MSC_PAGELOCK4_TGL	RW	Main Space Page 128-159 Lock Word
0x3134	MSC_PAGELOCK5_TGL	RW	Main Space Page 160-191 Lock Word

6.8 MSC Register Description

6.8.1 MSC_IPVERSION - IP Version ID

Offset	Bit Position																															
0x000	31	30	29	28	27	26	25	24	23	22	21	20	19	18	17	16	15	14	13	12	11	10	9	8	7	6	5	4	3	2	1	0
Reset																	0x3															
Access																	R															
Name																	IPVERSION															

Bit	Name	Reset	Access	Description
31:0	IPVERSION IP Version ID	0x3	R	IP Version ID

6.8.2 MSC_READCTRL - Read Control Register

Offset	Bit Position																																
0x004	31	30	29	28	27	26	25	24	23	22	21	20	19	18	17	16	15	14	13	12	11	10	9	8	7	6	5	4	3	2	1	0	
Reset												0x2																					
Access												RW																					
Name												MODE																					

Bit	Name	Reset	Access	Description
31:22	<i>Reserved</i>	<i>To ensure compatibility with future devices, always write Reserved bits to their reset value, unless otherwise stated. More information in 1.2 Conventions</i>		
21:20	MODE	0x2	RW	Read Mode When changing to a higher frequency, this register must be set to a large number of wait states before the core clock is switched to the higher frequency. When changing to a lower frequency, this register should be set to a lower number of wait states after the frequency transition has been completed. The maximum frequency for each wait state setting is listed in the datasheet.
	Value	Mode	Description	
	0	WS0	Zero wait-states inserted in fetch or read transfers	
	1	WS1	One wait-state inserted for each fetch or read transfer. See Flash Wait-States table for details	
	2	WS2	Two wait-states inserted for each fetch or read transfer. See Flash Wait-States table for details	
	3	WS3	Three wait-states inserted for each fetch or read transfer. See Flash Wait-States table for details	
19:0	<i>Reserved</i>	<i>To ensure compatibility with future devices, always write Reserved bits to their reset value, unless otherwise stated. More information in 1.2 Conventions</i>		

6.8.3 MSC_RDATACTRL - Read Data Control Register

Offset	Bit Position																															
0x008	31	30	29	28	27	26	25	24	23	22	21	20	19	18	17	16	15	14	13	12	11	10	9	8	7	6	5	4	3	2	1	0
Reset																					0x1								0x0			
Access																					RW								RW			
Name																					DOUTBUFEN								AFDIS			

Bit	Name	Reset	Access	Description
31:13	<i>Reserved</i>	<i>To ensure compatibility with future devices, always write Reserved bits to their reset value, unless otherwise stated. More information in 1.2 Conventions</i>		
12	DOUTBUFEN	0x1	RW	Flash dout pipeline buffer enable Flag to enable or bypass flash data output buffer
11:2	<i>Reserved</i>	<i>To ensure compatibility with future devices, always write Reserved bits to their reset value, unless otherwise stated. More information in 1.2 Conventions</i>		
1	AFDIS	0x0	RW	Automatic Invalidate Disable When this bit is set the cache is not automatically invalidated when a write or page erase is performed.
0	<i>Reserved</i>	<i>To ensure compatibility with future devices, always write Reserved bits to their reset value, unless otherwise stated. More information in 1.2 Conventions</i>		

6.8.4 MSC_WRITECTRL - Write Control Register

Offset	Bit Position																																			
0x00C	31	30	29	28	27	26	25	24	23	22	21	20	19	18	17	16	15	14	13	12	11	10	9	8	7	6	5	4	3	2	1	0				
Reset																	0x0																0x0		0x0	0x0
Access																	RW																RW		RW	RW
Name																	RANGECOUNT																LPWRITE		IRQERASEABORT	WREN

Bit	Name	Reset	Access	Description
31:26	<i>Reserved</i>	<i>To ensure compatibility with future devices, always write Reserved bits to their reset value, unless otherwise stated. More information in 1.2 Conventions</i>		
25:16	RANGECOUNT	0x0	RW	EraseRange Count Apply only with EraseRange command. Define number of pages to be erased.
15:4	<i>Reserved</i>	<i>To ensure compatibility with future devices, always write Reserved bits to their reset value, unless otherwise stated. More information in 1.2 Conventions</i>		
3	LPWRITE	0x0	RW	Low-Power Write When set, write times might double while reducing current consumption
2	<i>Reserved</i>	<i>To ensure compatibility with future devices, always write Reserved bits to their reset value, unless otherwise stated. More information in 1.2 Conventions</i>		
1	IRQERASEABORT	0x0	RW	Abort Page Erase on Interrupt When this bit is set to 1, any Cortex-M33 interrupt aborts any current page erase operation. Executing that interrupt vector from Flash will halt the CPU.
0	WREN	0x0	RW	Enable Write/Erase Controller When this bit is set, the MSC write and erase functionality is enabled

6.8.5 MSC_WRITECMD - Write Command Register

Offset	Bit Position																																																		
0x010	31	30	29	28	27	26	25	24	23	22	21	20	19	18	17	16	15	14	13	12	11	10	9	8	7	6	5	4	3	2	1	0																			
Reset												0x0												0x0												0x0	0x0		0x0	0x0		0x0	0x0								
Access												W												W												W	W		W	W		W	W								
Name												CLEARWDATA												ERASEMAIN0												ERASEABORT	ERASERANGE		WRITEEND	ERASEPAGE											

Bit	Name	Reset	Access	Description
31:13	<i>Reserved</i>	<i>To ensure compatibility with future devices, always write Reserved bits to their reset value, unless otherwise stated. More information in 1.2 Conventions</i>		
12	CLEARWDATA	0x0	W	Clear WDATA state Will set WDATAREADY and DMA request. Should only be used when no write is active.
11:9	<i>Reserved</i>	<i>To ensure compatibility with future devices, always write Reserved bits to their reset value, unless otherwise stated. More information in 1.2 Conventions</i>		
8	ERASEMAIN0	0x0	W	Mass erase region 0 Initiate mass erase of flash memory. If MELOCKBIT in MSC_MISCLOCKWORD is set, user firmware cannot initiate mass erase, and only the SE may initiate mass erase.
7:6	<i>Reserved</i>	<i>To ensure compatibility with future devices, always write Reserved bits to their reset value, unless otherwise stated. More information in 1.2 Conventions</i>		
5	ERASEABORT	0x0	W	Abort erase sequence Writing to this bit will abort an ongoing erase sequence.
4	ERASERANGE	0x0	W	Erase range of pages Erase a range of user defined pages started from the MSC_ADDRB register. The WREN bit in the MSC_WRITECTRL register must be set in order to use this command.
3	<i>Reserved</i>	<i>To ensure compatibility with future devices, always write Reserved bits to their reset value, unless otherwise stated. More information in 1.2 Conventions</i>		
2	WRITEEND	0x0	W	End Write Mode Write 1 to abort a write command.
1	ERASEPAGE	0x0	W	Erase Page Erase any user defined page selected by the MSC_ADDRB register. The WREN bit in the MSC_WRITECTRL register must be set in order to use this command.
0	<i>Reserved</i>	<i>To ensure compatibility with future devices, always write Reserved bits to their reset value, unless otherwise stated. More information in 1.2 Conventions</i>		

6.8.6 MSC_ADDRB - Page Erase/Write Address Buffer

Offset	Bit Position																															
0x014	31	30	29	28	27	26	25	24	23	22	21	20	19	18	17	16	15	14	13	12	11	10	9	8	7	6	5	4	3	2	1	0
Reset	0x0																															
Access	RW																															
Name	ADDRB																															

Bit	Name	Reset	Access	Description
31:0	ADDRB	0x0	RW	Page Erase or Write Address Buffer
This register holds the system address for the erase or write operation. Address should be word aligned address. The MSB bit is not ignored for ADDRBRB				

6.8.7 MSC_WDATA - Write Data Register

Offset	Bit Position																															
0x018	31	30	29	28	27	26	25	24	23	22	21	20	19	18	17	16	15	14	13	12	11	10	9	8	7	6	5	4	3	2	1	0
Reset	0x0																															
Access	RW																															
Name	DATAW																															

Bit	Name	Reset	Access	Description
31:0	DATAW	0x0	RW	Write Data
The data to be written to the address in MSC_ADDRB. This register must be written when the WDATAREADY bit of MSC_STATUS is set. This register does not support write mask.				

6.8.8 MSC_STATUS - Status Register

Offset	Bit Position																																		
0x01C	31	30	29	28	27	26	25	24	23	22	21	20	19	18	17	16	15	14	13	12	11	10	9	8	7	6	5	4	3	2	1	0			
Reset	0x0				0x1					0x0													0x0					0x0	0x0	0x0	0x0	0x1	0x0	0x0	0x0
Access	R				R					R													R					R	R	R	R	R	R	R	R
Name	PWRUPCKBDFAILCOUNT				WREADY					PWRON													REGLOCK					RANGEPARTIAL	TIMEOUT	PENDING	ERASEABORTED	WDATAREADY	INVADDR	LOCKED	BUSY

Bit	Name	Reset	Access	Description									
31:28	PWRUPCKBDFAIL-COUNT	0x0	R	Flash power up checkerboard pattern chec This field tells how many times checkboard pattern check fail occurred after a reset sequence.									
27	WREADY	0x1	R	Flash Write Ready When this bit is set, flash has completed the power up sequence and is ready for write/erase commands.									
26:25	<i>Reserved</i>	<i>To ensure compatibility with future devices, always write Reserved bits to their reset value, unless otherwise stated. More information in 1.2 Conventions</i>											
24	PWRON	0x0	R	Flash power on status When this bit is set, flash is powered on. If zero, flash is powered off and reads from flash return indeterminate data.									
23:17	<i>Reserved</i>	<i>To ensure compatibility with future devices, always write Reserved bits to their reset value, unless otherwise stated. More information in 1.2 Conventions</i>											
16	REGLOCK	0x0	R	Register Lock Status Indicates the current status of register lock <table border="1"> <thead> <tr> <th>Value</th> <th>Mode</th> <th>Description</th> </tr> </thead> <tbody> <tr> <td>0</td> <td>UNLOCKED</td> <td></td> </tr> <tr> <td>1</td> <td>LOCKED</td> <td></td> </tr> </tbody> </table>	Value	Mode	Description	0	UNLOCKED		1	LOCKED	
Value	Mode	Description											
0	UNLOCKED												
1	LOCKED												
15:8	<i>Reserved</i>	<i>To ensure compatibility with future devices, always write Reserved bits to their reset value, unless otherwise stated. More information in 1.2 Conventions</i>											
7	RANGEPARTIAL	0x0	R	EraseRange with skipped locked pages									
6	TIMEOUT	0x0	R	Write Command Timeout When this bit is set, it indicates that the last write command has completed due to a write buffer timeout. This bit is cleared automatically when a new write command is initiated.									
5	PENDING	0x0	R	Write Command In Queue When this bit is set, a flash operation has been requested but not yet started. New commands are ignored when PENDING is set.									
4	ERASEABORTED	0x0	R	Erase Operation Aborted									

Bit	Name	Reset	Access	Description
				When MSC_WRITECTRL_IRQERASEABORT = 1, this bit is set because an interrupt has aborted the erase operation in progress.
3	WDATAREADY	0x1	R	WDATA Write Ready When this bit is set, the content of MSC_WDATA is read by MSC Flash Write Controller and the register may be updated with the next 32-bit word to be written to flash. This bit is cleared when writing to MSC_WDATA.
2	INVADDR	0x0	R	Invalid Write Address or Erase Page When this bit is set, software has attempted to load an invalid (unmapped) address into the MSC_ADDRB register.
1	LOCKED	0x0	R	Access Locked When set, the last erase or write was aborted due to erase/write access constraints.
0	BUSY	0x0	R	Erase/Write Busy When set, an erase or write operation is in progress and new commands are ignored.

6.8.9 MSC_IF - Interrupt Flag Register

Offset	Bit Position																																									
0x020	31	30	29	28	27	26	25	24	23	22	21	20	19	18	17	16	15	14	13	12	11	10	9	8	7	6	5	4	3	2	1	0										
Reset																							0x0	0x0																0x0	0x0	0x0
Access																							RW	RW																RW	RW	RW
Name																							PWROFF	PWRUPF																WDATAOV	WRITE	ERASE

Bit	Name	Reset	Access	Description
31:10	<i>Reserved</i>	<i>To ensure compatibility with future devices, always write Reserved bits to their reset value, unless otherwise stated. More information in 1.2 Conventions</i>		
9	PWROFF	0x0	RW	Flash Power Off Sequence Complete Flag Set after MSC_CMD.PWROFF received, flash powered off complete
8	PWRUPF	0x0	RW	Flash Power Up Sequence Complete Flag Set after MSC_CMD.PWRUP received, flash powered up complete and ready for read/write
7:3	<i>Reserved</i>	<i>To ensure compatibility with future devices, always write Reserved bits to their reset value, unless otherwise stated. More information in 1.2 Conventions</i>		
2	WDATAOV	0x0	RW	Host write buffer overflow If set, flash controller write buffer overflow detected
1	WRITE	0x0	RW	Host Write Done Interrupt Read Flag Set when a write is done
0	ERASE	0x0	RW	Host Erase Done Interrupt Read Flag Set when erase is done

6.8.10 MSC_IEN - Interrupt Enable Register

Offset	Bit Position																																									
0x024	31	30	29	28	27	26	25	24	23	22	21	20	19	18	17	16	15	14	13	12	11	10	9	8	7	6	5	4	3	2	1	0										
Reset																							0x0	0x0																0x0	0x0	0x0
Access																							RW	RW																RW	RW	RW
Name																							PWROFF	PWRUPF																WDATAOV	WRITE	ERASE

Bit	Name	Reset	Access	Description
31:10	<i>Reserved</i>	<i>To ensure compatibility with future devices, always write Reserved bits to their reset value, unless otherwise stated. More information in 1.2 Conventions</i>		
9	PWROFF interrupt enable	0x0	RW	Flash Power Off Seq done irq enable
8	PWRUPF interrupt enable	0x0	RW	Flash Power Up Seq done irq enable
7:3	<i>Reserved</i>	<i>To ensure compatibility with future devices, always write Reserved bits to their reset value, unless otherwise stated. More information in 1.2 Conventions</i>		
2	WDATAOV interrupt enable	0x0	RW	write data buffer overflow irq enable
1	WRITE interrupt enable	0x0	RW	Write Done Interrupt enable
0	ERASE interrupt enable	0x0	RW	Erase Done Interrupt enable

6.8.11 MSC_USERDATASIZE - User Data Region Size Register

Offset	Bit Position																															
0x034	31	30	29	28	27	26	25	24	23	22	21	20	19	18	17	16	15	14	13	12	11	10	9	8	7	6	5	4	3	2	1	0
Reset																												0x4				
Access																												R				
Name																												USERDATASIZE				

Bit	Name	Reset	Access	Description
31:6	Reserved			To ensure compatibility with future devices, always write Reserved bits to their reset value, unless otherwise stated. More information in 1.2 Conventions
5:0	USERDATASIZE	0x4	R	User Data Size This field determines user data region size. SIZE = 256B * USERDATASIZE.

6.8.12 MSC_CMD - Command Register

Offset	Bit Position																															
0x038	31	30	29	28	27	26	25	24	23	22	21	20	19	18	17	16	15	14	13	12	11	10	9	8	7	6	5	4	3	2	1	0
Reset																												0x0				0x0
Access																												W				W
Name																												PWROFF				PWRUP

Bit	Name	Reset	Access	Description
31:5	Reserved			To ensure compatibility with future devices, always write Reserved bits to their reset value, unless otherwise stated. More information in 1.2 Conventions
4	PWROFF	0x0	W	Flash power off/sleep command Write to this bit to power down the Flash. User code should execute from RAM afterwards. Read from flash after flash being powered down will cause undetermined behavior. To power up, either set CMD.PWRUP bit or try read from flash.
3:1	Reserved			To ensure compatibility with future devices, always write Reserved bits to their reset value, unless otherwise stated. More information in 1.2 Conventions
0	PWRUP	0x0	W	Flash Power Up Command Write to this bit to power up the Flash. IRQ PWRUPF will be fired when power up sequence completed.

6.8.13 MSC_LOCK - Configuration Lock Register

Offset	Bit Position																															
0x03C	31	30	29	28	27	26	25	24	23	22	21	20	19	18	17	16	15	14	13	12	11	10	9	8	7	6	5	4	3	2	1	0
Reset																	0x0															
Access																	W															
Name																	LOCKKEY															

Bit	Name	Reset	Access	Description
31:16	Reserved	To ensure compatibility with future devices, always write Reserved bits to their reset value, unless otherwise stated. More information in 1.2 Conventions		
15:0	LOCKKEY	0x0	W	Configuration Lock Write any other value than the unlock code to lock access to MSC_RDATACTRL, MSC_READCTRL, and MSC_WRITECTRL. Write the unlock code to enable access. When reading the register, bit 0 is set when the lock is enabled.
	Value	Mode	Description	
	0	LOCK		
	7025	UNLOCK		

6.8.14 MSC_MISLOCKWORD - Mass Erase and User Data Page Lock Word

Offset	Bit Position																															
0x040	31	30	29	28	27	26	25	24	23	22	21	20	19	18	17	16	15	14	13	12	11	10	9	8	7	6	5	4	3	2	1	0
Reset																									0x1				0x1			
Access																									RW				RW			
Name																									UDLOCKBIT				MELOCKBIT			

Bit	Name	Reset	Access	Description
31:5	Reserved	To ensure compatibility with future devices, always write Reserved bits to their reset value, unless otherwise stated. More information in 1.2 Conventions		
4	UDLOCKBIT	0x1	RW	User Data Lock Zero means host can write/erase to the user data area. Host is only allowed to write one. Root and debug can clear this bit.
3:1	Reserved	To ensure compatibility with future devices, always write Reserved bits to their reset value, unless otherwise stated. More information in 1.2 Conventions		
0	MELOCKBIT	0x1	RW	Mass Erase Lock Zero means host can mass erase the main space. Host is only allowed to write one. Root and debug can clear this bit.

6.8.15 MSC_PWRCTRL - Power Control Register

Offset	Bit Position																															
0x050	31	30	29	28	27	26	25	24	23	22	21	20	19	18	17	16	15	14	13	12	11	10	9	8	7	6	5	4	3	2	1	0
Reset									0x10																0x0			0x1	0x0			
Access									RW																RW			RW	RW			
Name									PWROFFDLY																PWROFFENTRYAGAIN			PWROFFONEM1PENTRY	PWROFFONEM1ENTRY			

Bit	Name	Reset	Access	Description
31:24	<i>Reserved</i>	<i>To ensure compatibility with future devices, always write Reserved bits to their reset value, unless otherwise stated. More information in 1.2 Conventions</i>		
23:16	PWROFFDLY	0x10	RW	Power down delay Defines delay cycles before flash enters sleep mode. Works together with PWROFFENTRYAGAIN bit. The power off delay is 64 * PWROFFDLY bus clock cycles.
15:5	<i>Reserved</i>	<i>To ensure compatibility with future devices, always write Reserved bits to their reset value, unless otherwise stated. More information in 1.2 Conventions</i>		
4	PWROFFENTRYAGAIN	0x0	RW	POWER down flash again in EM1/EM1p If enabled, flash will enter sleep mode again when POWEROFFONEM1ENTRY/POWEROFFONEM1PENTRY is set and no flash activities occur for the time determined by PWROFFDLY.
3:2	<i>Reserved</i>	<i>To ensure compatibility with future devices, always write Reserved bits to their reset value, unless otherwise stated. More information in 1.2 Conventions</i>		
1	PWROFFONEM1PENTRY	0x1	RW	Power down Flash macro when enter EM1P If enabled, flash will be in sleep mode when entering EM1P (radio-only sleep).
0	PWROFFONEM1ENTRY	0x0	RW	Power down Flash macro when enter EM1 If enabled, flash will be in sleep mode when entering EM1.

6.8.16 MSC_PAGELOCK0 - Main Space Page 0-31 Lock Word

Offset	Bit Position																															
0x120	31	30	29	28	27	26	25	24	23	22	21	20	19	18	17	16	15	14	13	12	11	10	9	8	7	6	5	4	3	2	1	0
Reset	0x0																															
Access	RW																															
Name	LOCKBIT																															

Bit	Name	Reset	Access	Description
31:0	LOCKBIT	0x0	RW	page lock bit
Zero means the corresponding page is allowed to write/erase. change to one will prevent corresponding page from write/erase. bit[0] for main space page 0, and bit[1] for page 1... bit[31] for page 31. Reset to zero. Host is only allowed to write one. Root and Debug are allowed to clear this register				

6.8.17 MSC_PAGELOCK1 - Main Space Page 32-63 Lock Word

Offset	Bit Position																															
0x124	31	30	29	28	27	26	25	24	23	22	21	20	19	18	17	16	15	14	13	12	11	10	9	8	7	6	5	4	3	2	1	0
Reset	0x0																															
Access	RW																															
Name	LOCKBIT																															

Bit	Name	Reset	Access	Description
31:0	LOCKBIT	0x0	RW	page lock bit
Zero means the corresponding page is allowed to write/erase. change to one will prevent corresponding page from write/erase. bit[0] for main space page 32, and bit[1] for page 33... bit[31] for page 63. Reset to zero. Host is only allowed to write one. Root and Debug are allowed to clear this register				

6.8.18 MSC_PAGELOCK2 - Main Space Page 64-95 Lock Word

Offset	Bit Position																															
0x128	31	30	29	28	27	26	25	24	23	22	21	20	19	18	17	16	15	14	13	12	11	10	9	8	7	6	5	4	3	2	1	0
Reset																																0x0
Access																																RW
Name																																LOCKBIT

Bit	Name	Reset	Access	Description
31:0	LOCKBIT	0x0	RW	page lock bit
Zero means the corresponding page is allowed to write/erase. change to one will prevent corresponding page from write/erase. bit[0] for main space page 64, and bit[1] for page 65... bit[31] for page 95. Reset to zero. Host is only allowed to write one. Root and Debug are allowed to clear this register				

6.8.19 MSC_PAGELOCK3 - Main Space Page 96-127 Lock Word

Offset	Bit Position																															
0x12C	31	30	29	28	27	26	25	24	23	22	21	20	19	18	17	16	15	14	13	12	11	10	9	8	7	6	5	4	3	2	1	0
Reset																																0x0
Access																																RW
Name																																LOCKBIT

Bit	Name	Reset	Access	Description
31:0	LOCKBIT	0x0	RW	page lock bit
Zero means the corresponding page is allowed to write/erase. change to one will prevent corresponding page from write/erase. bit[0] for main space page 96, and bit[1] for page 97... bit[31] for page 127. Reset to zero. Host is only allowed to write one. Root and Debug are allowed to clear this register				

6.8.20 MSC_PAGELOCK4 - Main Space Page 128-159 Lock Word

Offset	Bit Position																															
0x130	31	30	29	28	27	26	25	24	23	22	21	20	19	18	17	16	15	14	13	12	11	10	9	8	7	6	5	4	3	2	1	0
Reset																																0x0
Access																																RW
Name																																LOCKBIT

Bit	Name	Reset	Access	Description
31:0	LOCKBIT	0x0	RW	page lock bit
Zero means the corresponding page is allowed to write/erase. change to one will prevent corresponding page from write/erase. bit[0] for main space page 128, and bit[1] for page 129... bit[31] for page 159. Reset to zero. Host is only allowed to write one. Root and Debug are allowed to clear this register				

6.8.21 MSC_PAGELOCK5 - Main Space Page 160-191 Lock Word

Offset	Bit Position																															
0x134	31	30	29	28	27	26	25	24	23	22	21	20	19	18	17	16	15	14	13	12	11	10	9	8	7	6	5	4	3	2	1	0
Reset																																0x0
Access																																RW
Name																																LOCKBIT

Bit	Name	Reset	Access	Description
31:0	LOCKBIT	0x0	RW	page lock bit
Zero means the corresponding page is allowed to write/erase. change to one will prevent corresponding page from write/erase. bit[0] for main space page 160, and bit[1] for page 161... bit[31] for page 191. Reset to zero. Host is only allowed to write one. Root and Debug are allowed to clear this register				

7. DBG - Debug Interface

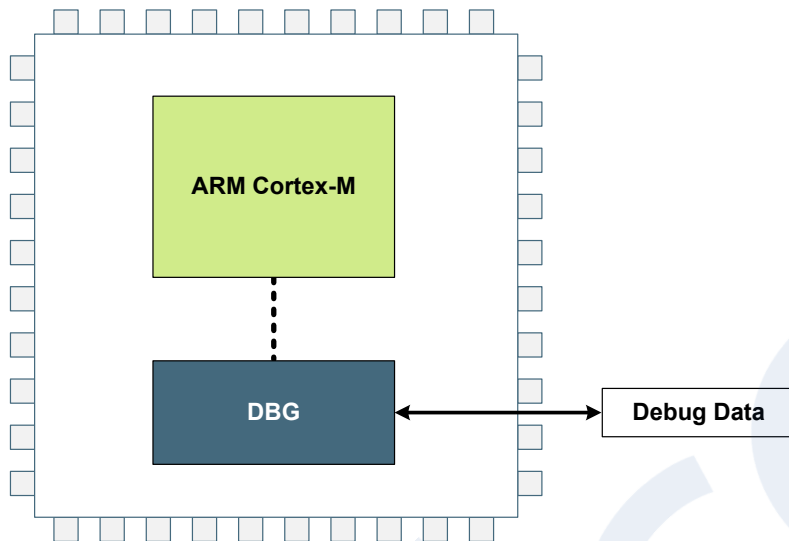
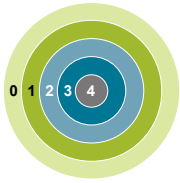

Quick Facts

What?

The Debug Interface is used to program and debug EFR32xG24 devices.

Why?

The Debug Interface makes it easy to re-program and update the system in the field, and allows debugging with minimal I/O pin usage.

How?

The Cortex®-M33 supports advanced debugging features. EFR32xG24 devices can use a minimum of two port pins for debugging or programming. The internal and external state of the system can be examined with debug extensions supporting instruction or data access break and watch points.

7.1 Introduction

The EFR32xG24 devices include hardware debug support through a 2-pin serial-wire debug (SWD) interface or a 4-pin Joint Test Action Group (JTAG) interface, as well as an Embedded Trace Module (ETM) for data/instruction tracing. In addition, there is also a Serial Wire Viewer pin which can be used to output profiling information, data trace and software-generated messages.

For more technical information about the debug interface the reader is referred to:

- ARM Cortex®-M33 Technical Reference Manual
- ARM CoreSight Components Technical Reference Manual
- ARM Debug Interface v5 Architecture Specification
- IEEE Standard for Test Access Port and Boundary-Scan Architecture, IEEE 1149.1-2013

7.2 Features

- Debug Access Port Serial Wire JTAG (DAPSWJ)
 - Implements the ADIV5 debug interface
- ARM Trustzone
 - Enables secure debugging
- Breakpoint unit (BPU)
 - Implement up to 8 hardware breakpoints
- Data Watch point and Trace (DWT) unit
 - Implement up to 4 watch points, trigger resources and system profiling
- Instrumentation Trace Macrocell (ITM)
 - Application-driven trace source that supports printf style debugging
- Embedded Trace Macrocell v3.5 (ETM)
 - Real time instruction and data trace information of the processor
- Cross Trigger Interface (CTI)
 - Issues synchronous triggers based on system events
 - Can be used to generate IRQs or route to PRS signalling

7.3 Functional Description

There are debug and trace pins available on the device. Operation of these pins is described in the following sections.

7.3.1 Debug Pins

The following pins are the debug connections for the device:

- Serial Wire Clock Input and Test Clock Input (SWCLKTCK) (SWCLK) : This pin is enabled after power-up and has a built-in pull-down.
- Serial Wire Data Input/Output and Test Mode Select Input (SWDIOTMS) (SWDIO) : This pin is enabled after power-up and has a built-in pull-up.
- Test Data Output (TDO): This pin is assigned to JTAG functionality after power-up. However, it remains in high-Z state until the first valid JTAG command is received.
- Test Data Input (TDI): This pin is assigned to JTAG functionality after power-up. However, it remains in high-Z state until the first valid JTAG command is received. Once enabled, the pin has a built-in pull-up.
- Serial Wire Viewer (SWV): This pin is disabled after reset.

The debug pins have integrated pull devices that are enabled by default after a reset. Leaving them enabled may increase current consumption if the pins are connected to power or ground. The debug pins have enable bits in the GPIO_DBGROUPEPEN register; refer to the GPIO chapter for more details. Upon disabling the debug pins, debug contact with the device is lost once the DAPSWJ power request bits are deasserted. By default after a power cycle, the DAPSWJ is in JTAG mode. If during a debugging session the device is switched to SWD mode, a power cycle is needed to return to JTAG mode.

7.3.2 Embedded Trace Macrocell (ETM)

ETM makes it possible to non-intrusively trace both instruction and data from the processor in real time. Trace can be controlled through a set of triggering and filtering resources. The resources include 4 address comparators, 2 data value comparators, 2 counters, a context ID comparator and a sequencer. Before enabling the ETM, the CMU_TRACECLKCTRL register must be configured to select the desired trace clock source. (See the CMU chapter for details.)

The trace can be exported through a set of trace pins, which include:

- Trace Clock (TRACECLK): Functions as a sample clock for the trace. This pin is disabled after reset.
- Trace Data 0-3 (TRACEDATA0, TRACEDATA1, TRACEDATA2, TRACEDATA3): The trace data pins provide the compressed trace stream. These pins are disabled after reset.

For information on how to configure the ETM, see the ARM Embedded Trace Macrocell Architecture Specification. The Trace Clock and Trace Data pins are enabled through a GPIO register. For more information on how to enable the ETM pins, refer to the GPIO chapter.

7.3.3 Debug and EM2/EM3

Debug connectivity in EM2 and EM3 is unavailable by default, to reduce current consumption. Debugging through EM2 and EM3 can be enabled by setting the EM2DBGGEN bit in the EMU_CTRL register. Setting EM2DBGGEN ensures that power domain associated with the debug circuitry will remain active, but will result in a small amount of additional current in EM2 and EM3.

Leaving the debugger connected when issuing a WFI or WFE to enter EM2 or EM3 will make the system enter a special EM2 mode. This mode differs from regular EM2 and EM3 in that the high frequency clocks are still enabled, and certain core functionality is still powered in order to maintain debug functionality. Because of this, the current consumption in this mode is closer to EM1, and it is, therefore, important to deassert the power requests in the DAPSWJ and disconnect the debugger before undertaking current consumption measurements.

8. CMU - Clock Management Unit

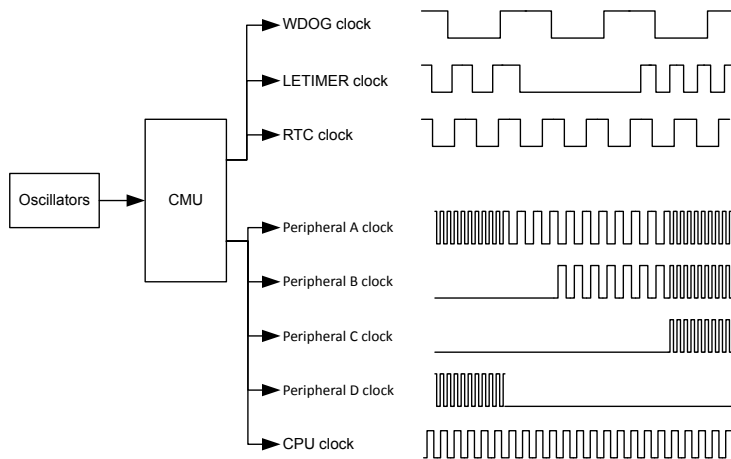

Quick Facts

What?

The CMU controls clock switching and distribution. EFR32xG24 supports several different oscillators with minimized power consumption and short start-up time. The CMU has HW support for calibration of RC oscillators.

Why?

Oscillators and clocks contribute significantly to the power consumption of the MCU. With the low power oscillators combined with the flexible clock control scheme, it is possible to minimize the energy consumption in any given application.

How?

The CMU switches different clock sources for various peripherals and sets the prescaler for the bus clocks. The short oscillator start-up times makes duty-cycling between active mode and the different low energy modes (EM2 DeepSleep, EM3 Stop, and EM4) very efficient. The calibration feature ensures high accuracy RC oscillators. Interrupts are available to avoid CPU polling of flags.

8.1 Introduction

The Clock Management Unit (CMU) is responsible for switching among various oscillator sources and provides clocks to the peripheral modules. Oscillators are automatically turned on and off based on demand from the peripherals to minimize power consumption.

8.2 Features

- Multiple clock sources available:
 - 38 MHz - 40 MHz High Frequency Crystal Oscillator (HFXO)
 - 1 MHz - 80 MHz High Frequency RC Oscillator (HFRCODPLL)
 - 1 MHz - 40 MHz Deep Sleep High Frequency RC Oscillator (HFRCOEM23)
 - 20 MHz Fast Startup RC Oscillator (FSRCO)
 - 1 MHz - 38 MHz External Clock from Input Pins (CLKIN0)
 - 32.768 kHz Low Frequency Crystal Oscillator (LFXO)
 - 32.768 kHz Low Frequency RC Oscillator (LFRCO) with Precision Mode
 - 1000 Hz Ultra Low Frequency RC Oscillator (ULFRCO)
- On-demand oscillator request.
- Low power oscillators.
- Fast start-up times.
- Cascaded prescalers for AHB Clocks (HCLK) and APB Clocks (PCLK).
- Clock gating on an individual basis to all peripherals based on module enable.
- Reset on an individual basis for Timer and IADC based on module enable.
- Selectable clocks can be output on external pins and/or PRS.
- Deep Sleep High Frequency RC oscillator (HFRCOEM23) or the Fast-start oscillator (FSRCO), which are asynchronous to the system clock, can be selected for IADC or VDAC0/1 operation in EM2.
- Hardware support for calibration of RC oscillators.

8.3 Functional Description

The CMU is comprised of several programmable clock trees, which connect oscillator resources to peripherals and buses. This section describes clock sources and peripherals available to the largest devices in the EFR32xG24 family. Please refer to the Configuration Summary in the Device Datasheet to see which core and peripheral modules, and therefore clock connections, are present in a specific device. Bus clock selection, including peripherals clocked directly from bus clocks, is shown in [Figure 8.1 Bus Clocks on page 149](#). Clock selection for peripherals with multiple high-frequency clock sources is shown in [Figure 8.2 High Frequency Peripheral Clocks on page 150](#). Clock selection for peripherals with multiple low-frequency clock sources is shown in [Figure 8.3 Low Frequency Peripheral Clocks on page 151](#). Clock selection for peripherals that can select from a high or low frequency clock source is shown in [Figure 8.4 Mixed Frequency Peripheral Clocks on page 152](#).

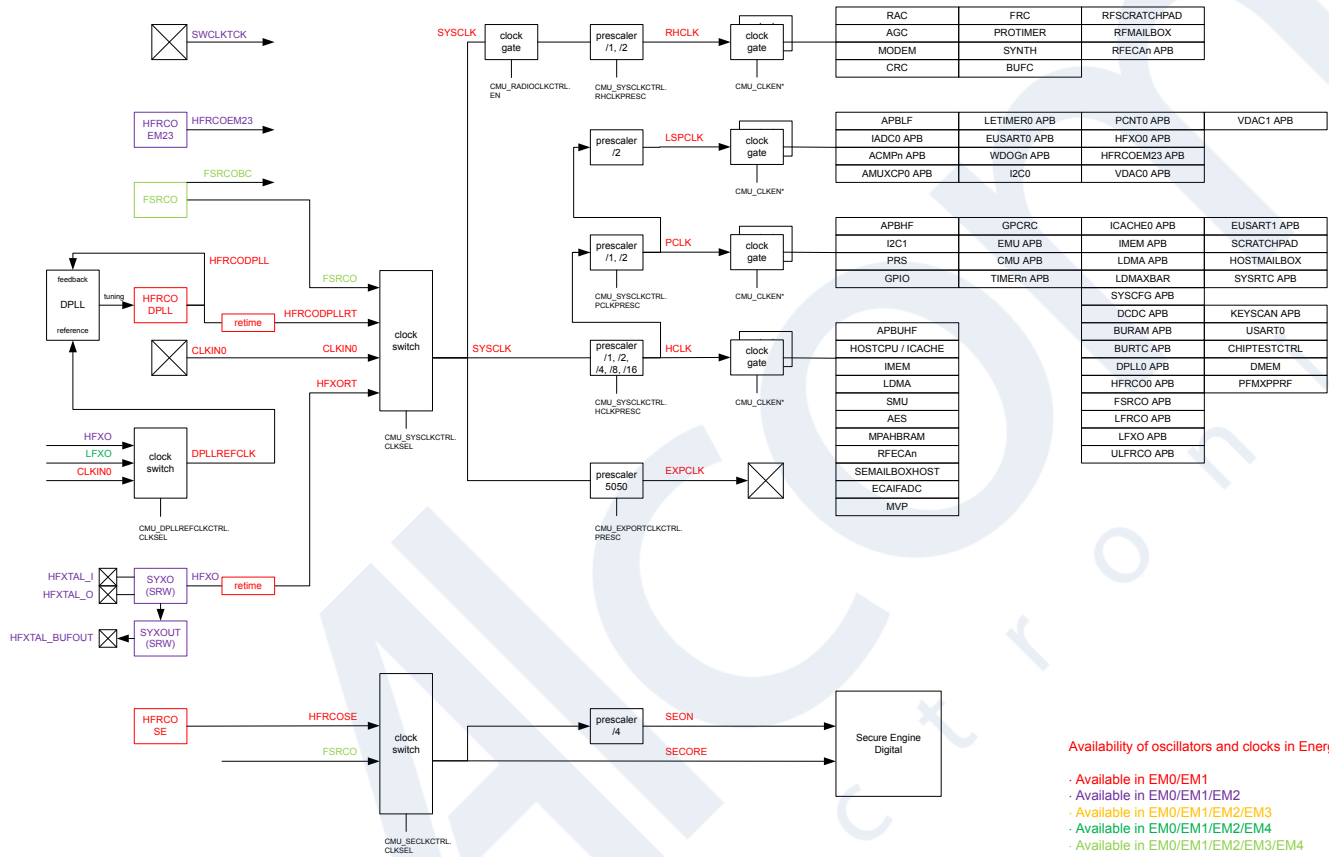
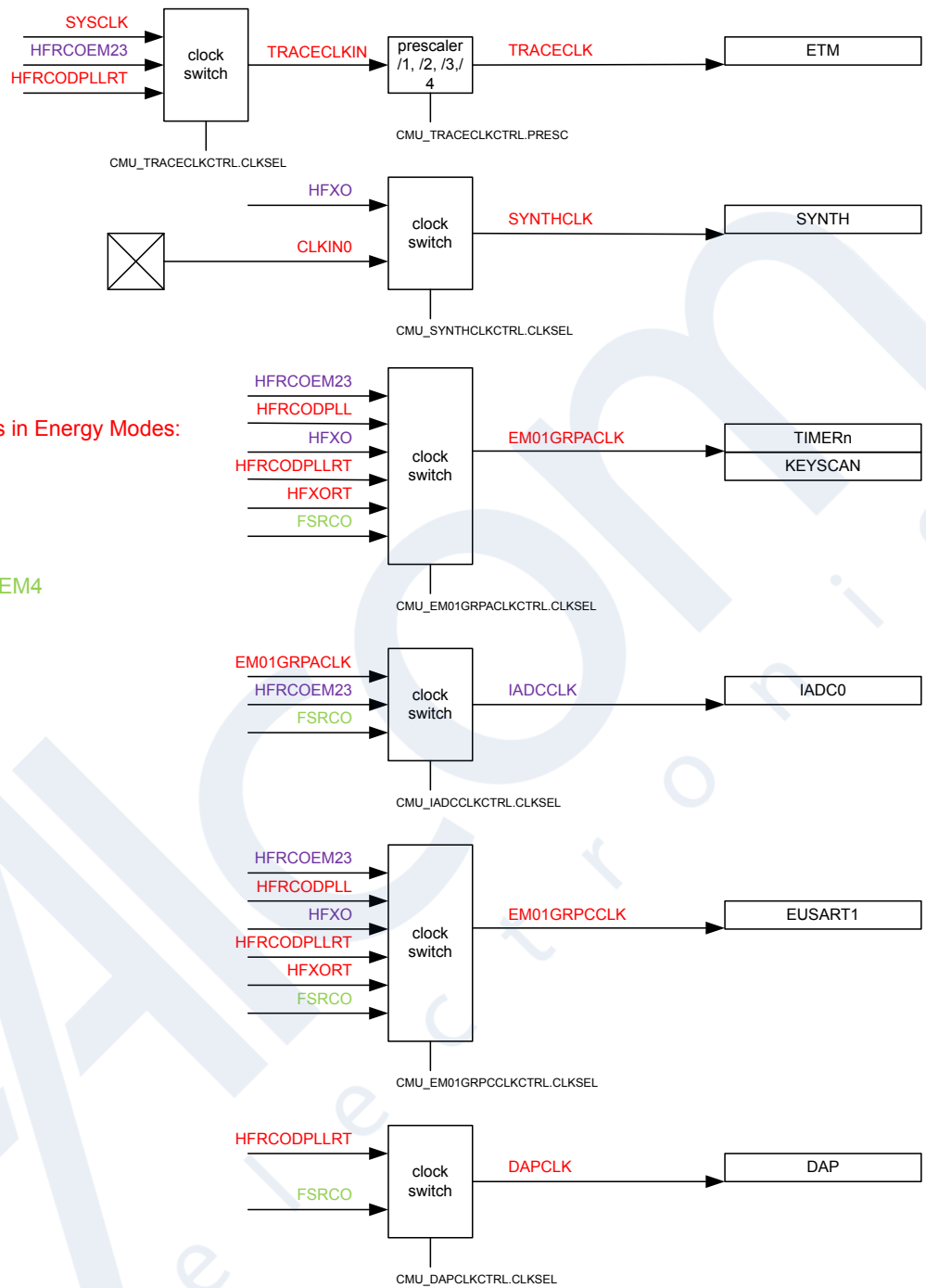

Figure 8.1. Bus Clocks



Availability of oscillators and clocks in Energy Modes:

- Available in EM0/EM1
- Available in EM0/EM1/EM2
- Available in EM0/EM1/EM2/EM3
- Available in EM0/EM1/EM2/EM4
- Available in EM0/EM1/EM2/EM3/EM4

Figure 8.2. High Frequency Peripheral Clocks

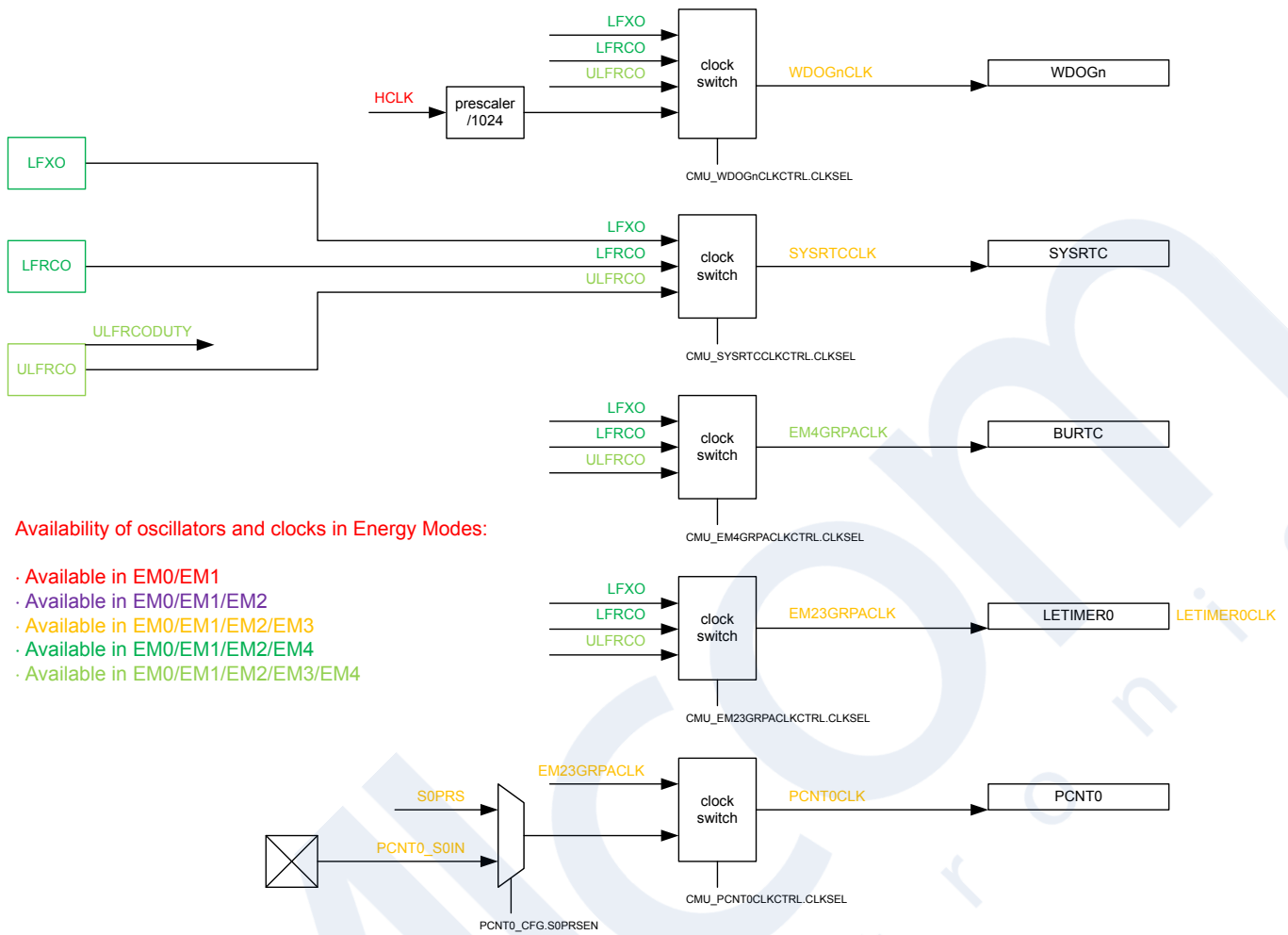

Availability of oscillators and clocks in Energy Modes:

- Available in EM0/EM1
- Available in EM0/EM1/EM2
- Available in EM0/EM1/EM2/EM3
- Available in EM0/EM1/EM2/EM4
- Available in EM0/EM1/EM2/EM3/EM4

Figure 8.3. Low Frequency Peripheral Clocks

Availability of oscillators and clocks in Energy Modes:

- Available in EM0/EM1
- Available in EM0/EM1/EM2
- Available in EM0/EM1/EM2/EM3
- Available in EM0/EM1/EM2/EM4
- Available in EM0/EM1/EM2/EM3/EM4

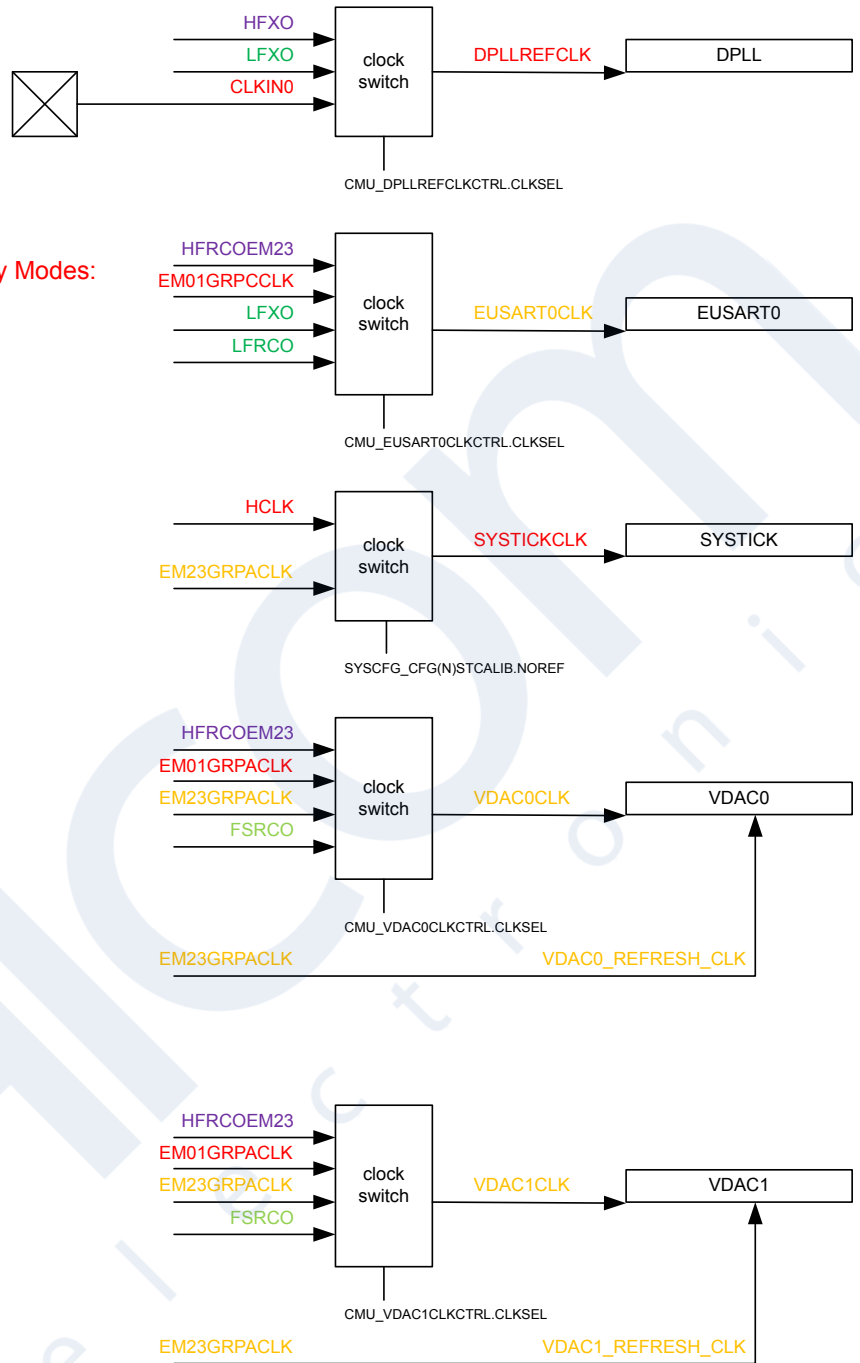

Figure 8.4. Mixed Frequency Peripheral Clocks

8.3.1 System Clocks

8.3.1.1 SYSCLK - Bus Clock

SYSCLK is the selected System Clock. HCLK is an optionally prescaled version of SYSCLK. PCLK is an optionally prescaled version of HCLK. The SYSCLK, and therefore HCLK and PCLK, can be driven by a high-frequency oscillator or be driven from a pin. The system boots using the FSRCO oscillator, and switches to HFRCODPLL before user firmware execution begins. To change the selected clock source, write to the CLKSEL bitfield in CMU_SYSCLKCTRL. If an invalid option is programmed into CLKSEL, FSRCO will be selected. The SYSCLK is running in EM0 Active and EM1 Sleep and is automatically stopped in EM2 DeepSleep.

The prescaler setting can be changed dynamically and the new setting takes effect immediately. When switching to a higher frequency oscillator source, prescaler setting should be adjusted before clock selection to prevent over clocking. For the same reason, when switching to a lower frequency oscillator source, prescaler setting cannot be adjusted until the clock selection is made.

The HFXO clock is fed directly to the Radio Transceiver. The clock received by the Radio Transceiver is therefore not affected by the selected clock source for SYSCLK nor by any clock prescaler.

8.3.1.2 HCLK - AHB Clock

HCLK is a prescaled version of SYSCLK. This clock drives the AHB bus interface. HCLK can be prescaled by setting HCLKPRESC in CMU_SYSCLKCTRL to DIV2 or DIV4. This prescales HCLK to all AHB bus clocks and is typically used to save energy in applications where the system is not required to run at the highest frequency. The setting can be changed dynamically and the new setting takes effect immediately. Some of the modules that are driven by this clock can be clock gated completely when not in use. This is done by clearing the module enable (EN) bit in the module's EN register.

8.3.1.3 PCLK - APB Clock

PCLK is a prescaled version of HCLK. This clock drives the APB bus interface. PCLK can be prescaled by setting PCLKPRESC in CMU_SYSCLKCTRL to DIV2. This prescales PCLK to all APB bus clocks and is necessary to prevent PCLK from exceeding the maximum frequency when HCLK is operated at above 40 MHz. The setting can be changed dynamically and the new setting takes effect immediately. Some of the peripherals that are driven by this clock can be clock gated completely when not in use. This is done by clearing the module enable (EN) bit in the module's EN register.

8.3.1.4 LSPCLK - Low Speed APB Clock

LSPCLK is a prescaled version of PCLK. This clock drives the Low Speed APB bus interface. LSPCLK is always prescaled by two. This prescales LSPCLK to all Low Speed APB bus clocks. Some of the peripherals that are driven by this clock can be clock gated completely when not in use. This is done by clearing the module enable (EN) bit in the module's EN register.

8.3.1.5 RHCLK - AHB Radio Clock

The radio AHB clock (RHCLK) is a prescaled version of SYSCLK. The maximum frequency for RHCLK is 40 MHz. The RHCLKPRESC setting in CMU_SYSCLKCTRL allows for SYSCLK to pass through (DIV1) or apply a divide-by-2 (DIV2) to the clock.

8.3.1.6 EM01GRPACLK - Energy Mode 01 Group A Clock

EM01GRPACLK is the selected clock for the Group A Peripherals operating in Energy Modes 0 or 1. These are typically high clock frequency peripheral modules. There are several selectable sources for EM01GRPACLK: HFXO, HFRCODPLL, HFRCOEM23, and FSRCO. In addition, the EM01GRPACLK can be disabled. The selection is configured using the CLKSEL field in CMU_EM01GRPACLKCTRL.

Each High Frequency Peripheral that is clocked by EM01GRPACLK may have its own prescaler setting and enable bit. The prescaler settings, if available, can be found in the peripheral's control registers. The enable bit can be found in the module's EN register.

8.3.1.7 EM01GRPCCLK - Energy Mode 01 Group C Clock

EM01GRPCCLK is the selected clock for the Group C Peripherals operating in Energy Modes 0 or 1. These are typically high clock frequency peripheral modules. There are several selectable sources for EM01GRPCCLK: HFXO, HFRCODPLL, HFRCOEM23, FSRCO, HFRCODPLLRT, and HFXORT. In addition, the EM01GRPCCLK can be disabled. The selection is configured using the CLKSEL field in CMU_EM01GRPCCLKCTRL.

Each High Frequency Peripheral that is clocked by EM01GRPCCLK may have its own prescaler setting and enable bit. The prescaler settings, if available, can be found in the peripheral's control registers. The enable bit can be found in the module's EN register.

8.3.1.8 EM23GRPACLK - Energy Mode 2 and 3 Group A Clock

EM23GRPACLK is the selected clock for the Group A Peripherals operating down to Energy Modes 2 or 3. These are typically low energy consumption peripheral modules. There are three selectable sources for EM23GRPACLK: LFRCO, LFXO and ULFRCO. In addition, the EM23GRPACLK can be disabled. The selection is configured using the CLKSEL field in CMU_EM23GRPACLKCTRL.

Each Low Energy Peripheral that is clocked by EM23GRPACLK may have its own prescaler setting and enable bit. The prescaler settings, if available, can be found in the peripheral's control registers. The enable bit can be found in the module's EN register.

8.3.1.9 EM4GRPACLK - Energy Mode 4 Group A Clock

EM4GRPACLK is the selected clock for the Group A Peripherals operating down to Energy Mode 4. These are typically ultra low energy consumption peripheral modules. There are three selectable sources for EM4GRPACLK: LFRCO, LFXO and ULFRCO. In addition, the EM4GRPACLK can be disabled. The selection is configured using the CLKSEL field in CMU_EM4GRPACLKCTRL.

Note: EM4GRPACLK is in a different power domain than EM23GRPACLK, which makes it available all the way down to EM4.

Each Low Energy Peripheral that is clocked by EM4GRPACLK may have its own prescaler setting and enable bit. The prescaler settings, if available, can be found in the peripheral's control registers. The enable bit can be found in the module's EN register.

8.3.1.10 Peripheral Bus Clock Enable

Peripherals each have an individual bus clock enable bit in the CMU_CLKEN0 or CMU_CLKEN1 registers. Disabling the bus clock to a peripheral can save energy, even when that peripheral is not active.

8.3.1.11 IADCCLK - IADC Clock

IADCCLK is the selected clock for the IADC. The IADCCLK source may be selected from EM01GRPACLK, HFRCOEM23, or FSRCO. In addition, the IADCCLK can be disabled. The selection is configured using the CLKSEL field in CMU_IADCCLKCTRL.

Note: When using a Timer as the synchronous trigger for IADC conversion, EM01GRPACLK must be selected, because Timers run from EM01GRPACLK.

IADC has its own prescaler setting and enable bit. The prescaler settings can be found in the IADC's control registers. The enable bit can be found in the IADC's EN register.

Whichever clock source is selected as the IADC clock via the CLKSEL bitfield in the CMU_IADCCLKCTRL register, this clock will become active automatically when needed. The IADC can automatically start and stop it.

8.3.1.12 VDACnCLK - VDACn Clock

VDACnCLK is the selected clock for VDACn. The VDACnCLK source may be selected from EM01GRPACLK, EM23GRPACLK, HFRCOEM23, or FSRCO. In addition, the VDACnCLK can be disabled. The selection is configured using the CLKSEL field in CMU_VDACnCLKCTRL.

Note: When using a Timer as the synchronous trigger for VDACn conversion, EM01GRPACLK must be selected, because Timers run from EM01GRPACLK.

VDACn has its own prescaler setting and enable bit. The prescaler settings can be found in the VDAC's control registers. The enable bit can be found in the VDAC's EN register.

Whichever clock source is selected as the VDACn clock via the CLKSEL bitfield in the CMU_VDACnCLKCTRL register, this clock will become active automatically when needed. The VDACn can automatically start and stop it.

8.3.1.13 SYSRTCCLK - SYSRTC Clock

SYSRTCCLK is the selected clock for the SYSRTC peripheral. This clock tree can be clocked from any of the low-frequency oscillators: LFXO, LFRCO, or ULFRCO. SYSRTCCLK is selected via the CLKSEL field in CMU_SYSRTCCLKCTRL.

8.3.1.14 PCNT0CLK - PCNT0 Clock

PCNT0CLK is the selected clock for the PCNT peripheral. PCNT can be configured to clock from its S0 input signal, or the EM23GRPACLK, selectable by the CLKSEL field in CMU_PCNT0CLKCTRL. Note that when configured to clock from the S0 input, the clock can further be selected from the direct S0 input pin, or from a PRS channel. Selection of the S0 input is determined by S0PRSEN in PCNT_CFG.

8.3.1.15 EUSART0CLK - EUSART0 Clock

EUSART0CLK is the selected clock for the EUSART0 peripheral, and can choose between EM01GRPACLK, HFRCOEM23, LFXO, and LFRCO. EUSART0CLK is selected via the CLKSEL field in CMU_EUSART0CLKCTRL. When operating EUSART0 as a high-speed UART or SPI main interface (EM0/1 only), EM01GRPACLK or HFRCOEM23 must be selected. To operate as a low-energy UART in EM0, EM1, or EM2, LFXO or LFRCO must be selected. To operate as a SPI secondary interface, EM01GRPACLK or HFRCOEM23 should be selected.

8.3.1.16 TRACECLK - Debug Trace Clock

The CMU scales the clock used for debug trace via the PRESC field in the CMU_TRACECLKCTRL register. The debug trace clock is limited to 40 MHz maximum. Therefore, if the SYSCLK is 40 MHz or less, the default DIV1 setting may be used. When SYSCLK is above 40 MHz, use DIV2 to avoid data pump overflow. The selected debug trace clock will be used to run the Cortex®-M33 trace logic. Note that this register should be configured properly before enabling ETM.

8.3.1.17 WDOGnCLK - Watchdog Timer Clock

The Watchdog Timer (WDOGn) can be configured to use one of four different clock sources: LFRCO, LFXO, ULFRCO, or HCLKDIV1024. Select option HCLKDIV1024 to track Watchdog timeout with CPU clock speed.

8.3.2 Switching Clock Source

The FSRCO oscillator is a fixed frequency (20 MHz), low energy oscillator with extremely short start-up time. Therefore, this oscillator is chosen by hardware as the clock source for SYSCLK when the device starts up (e.g. after reset).

Software can switch between the different clock sources at run-time. For example, when the HFRCODPLL is the clock source, software can switch to HFXO by writing the field CLKSEL in the CMU_SYCLKCTRL register. See [Figure 8.5 CMU Switching From HFRCO to HFXO Before HFXO is Ready on page 156](#) for a description of the sequence of events for this specific operation.

When switching the SYSCLK to HFXO via the CLKSEL bitfield in CMU_SYCLKCTRL, HFXO is automatically started. Switching to an oscillator that is not ready yet, the SYSCLK will stop for the duration of the oscillator start-up time. This effectively stalls the Core Modules. It is possible to avoid this by first enabling the target oscillator (e.g. HFXO) and then waiting for that oscillator to become ready before switching the clock source. This way, the system continues to run on the HFRCO until the target oscillator (e.g. HFXO) is ready and provides a reliable clock. This sequence of events is shown in [Figure 8.6 CMU Switching From HFRCO to HFXO After HFXO is Ready on page 157](#).

Generally, all oscillators have a separate flag that is set when the oscillator is ready. This flag can also be configured to generate an interrupt.

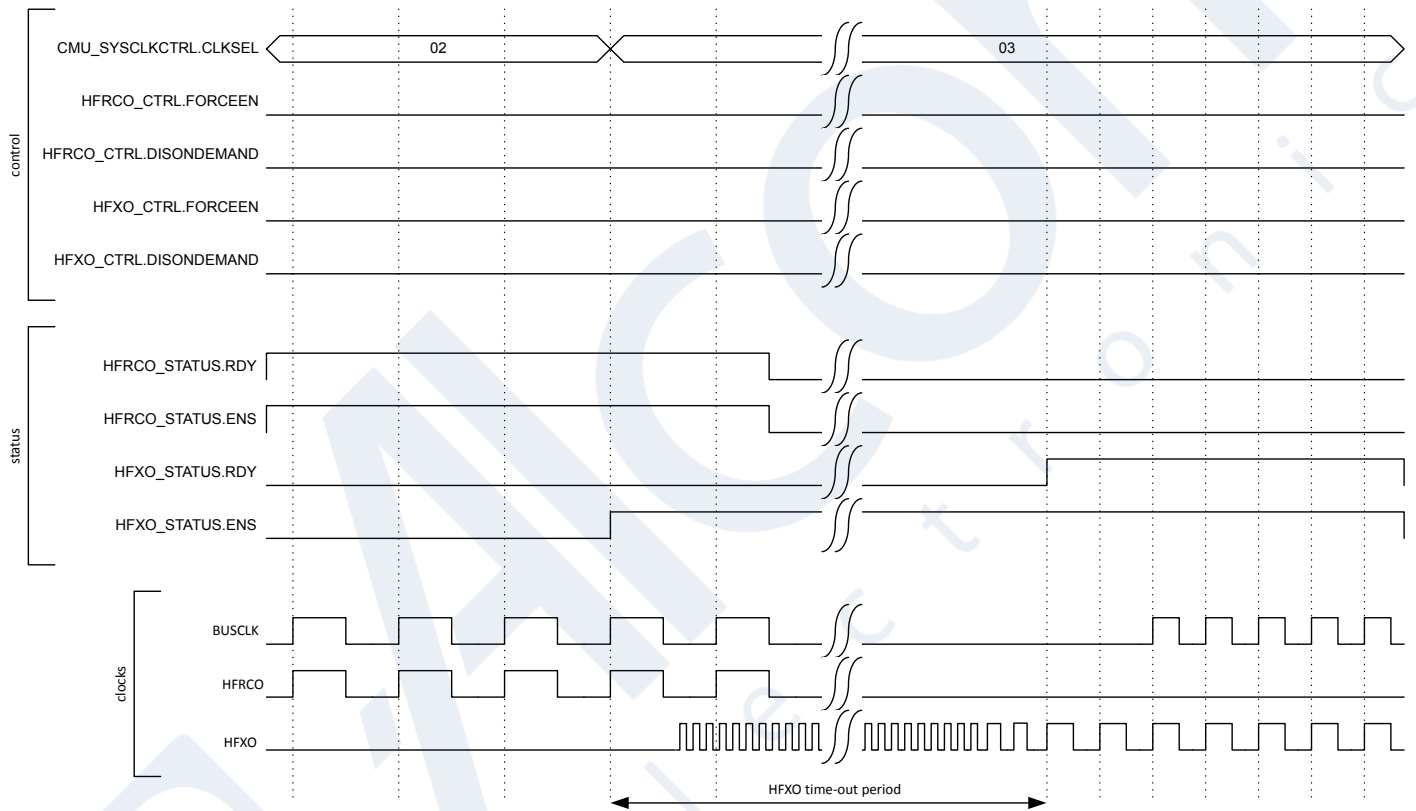

Figure 8.5. CMU Switching From HFRCO to HFXO Before HFXO is Ready

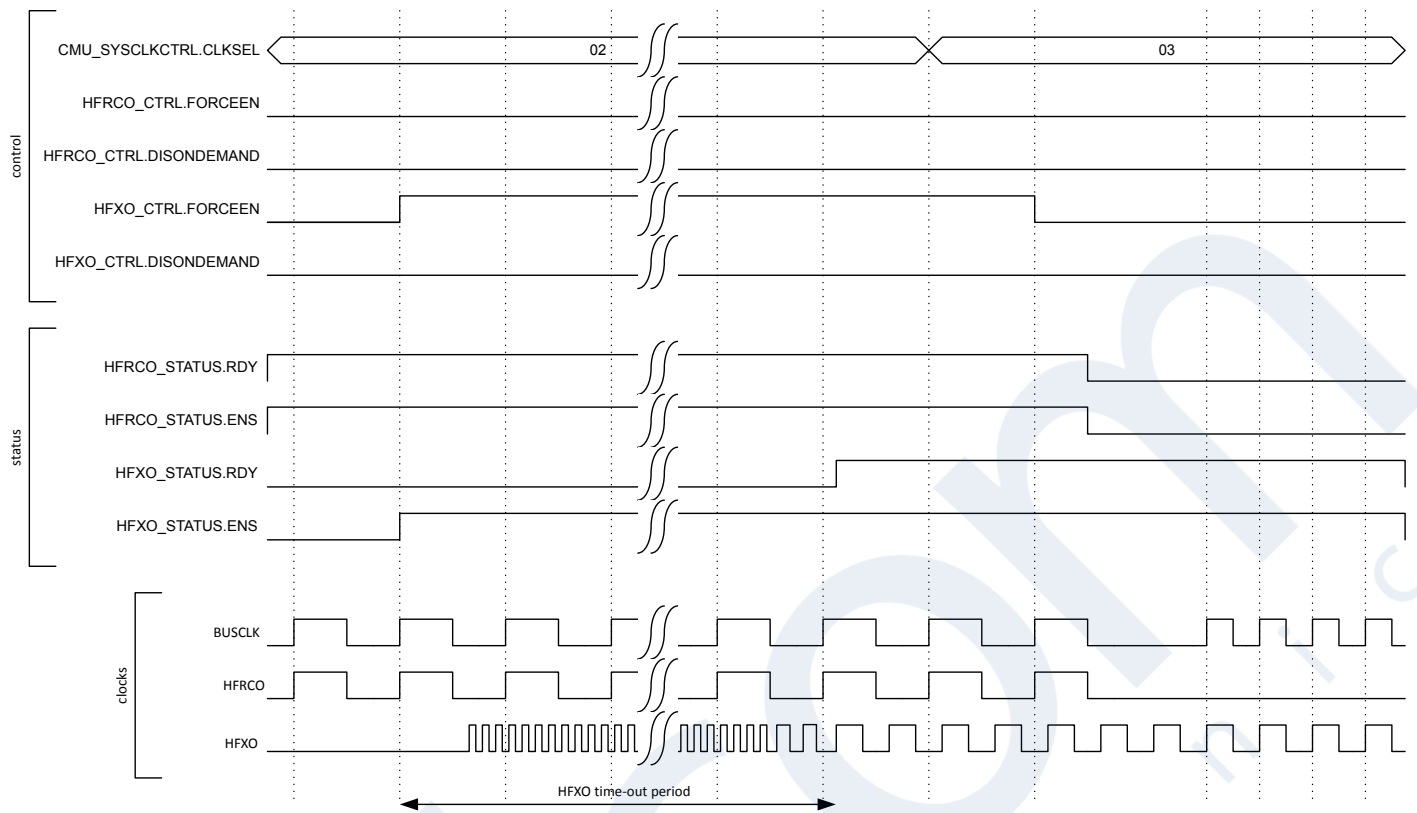

Figure 8.6. CMU Switching From HFRCO to HFXO After HFXO is Ready

Switching clock source for various clock switches is done by setting the CLKSEL bitfields in `CMU_*CLKCTRL`. To ensure no stalls in the peripherals, the clock source should be ready before switching to it.

Note: To save energy, remember to disable all clock switches and/or module enable bits when not in use.

8.3.3 RC Oscillator Calibration

The CMU has built-in hardware support to efficiently calibrate RC oscillators (LFRCO, HFRCODPLL, HFRCOEM23) at run-time or measure the timing of other periodic signals routed via PRS, see [Figure 8.7 Hardware Support for RC Oscillator Calibration on page 158](#) for an illustration of this circuit.

The concept is to select a reference and compare the RC frequency or PRS timing with the reference frequency. When the calibration circuit is started, one down-counter running on a selectable clock (DOWNSEL in CMU_CALCTRL) and one up-counter running on a selectable clock (UPSEL in CMU_CALCTRL) are started simultaneously. Reference clocks may also be routed through the PRS channels via the CALUP and CALDN consumer inputs. The top value for the down-counter must be written (CALTOP in CMU_CALCTRL) before calibration is started. The down-counter counts for CALTOP + 1 cycles. When the down-counter has reached 0, the up-counter is sampled and the CALRDY interrupt flag in the IF register is set. If CONT in CMU_CALCTRL is cleared, the counters are stopped after finishing the ongoing calibration. If continuous mode is selected by setting CONT in CMU_CALCTRL, the down-counter reloads the top value and continues counting, while the up-counter restarts from 0.

Software can then read out the sampled up-counter value from CMU_CALCNT. The up-counter has counted (the sampled value)+ 1 cycles. The ratio between the reference and the oscillator subject to the calibration can easily be found using (the top value)+1 and (the sampled value)+1. Overflows of the up-counter will not occur. If the up-counter reaches its top value before the down-counter reaches 0, the up-counter stays at its top value. Calibration can be started and stopped by writing CALSTART and CALSTOP bitfields in CMU_CALCMD, respectively. With this hardware support, it is simple to write efficient software calibration algorithms.

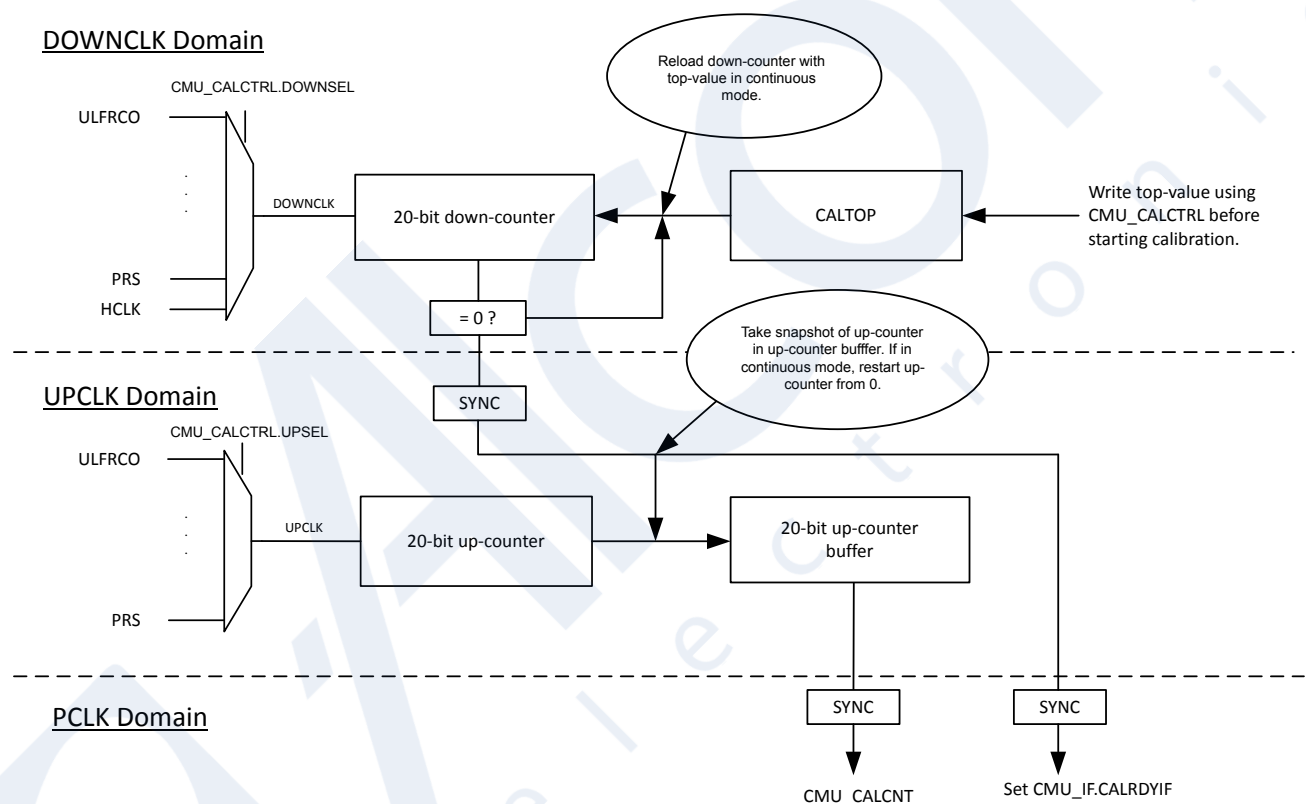

Figure 8.7. Hardware Support for RC Oscillator Calibration

The counter operation for single and continuous mode are shown in [Figure 8.8 Single Calibration \(CONT=0\) on page 159](#) and [Figure 8.9 Continuous Calibration \(CONT=1\) on page 160](#) respectively.

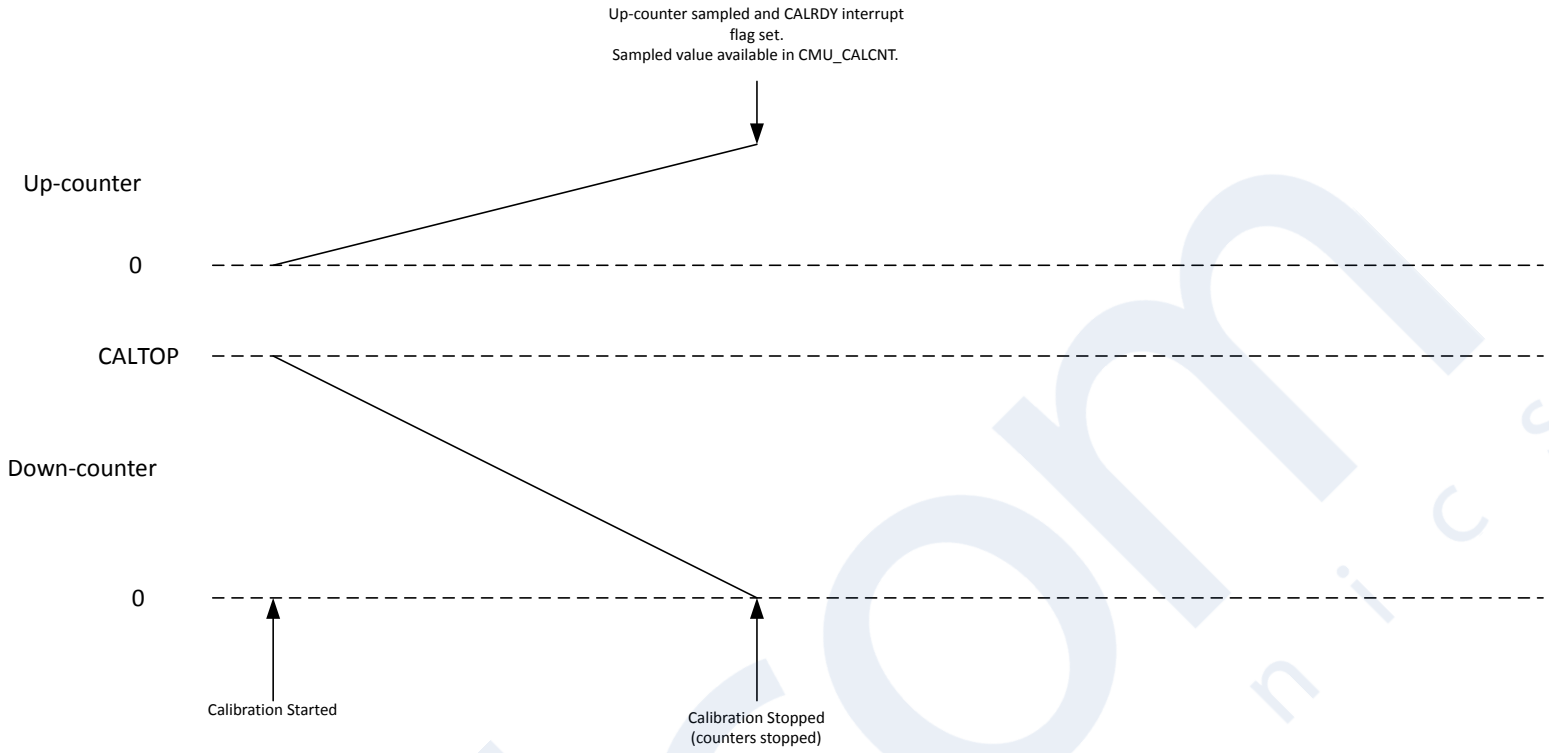

Figure 8.8. Single Calibration (CONT=0)

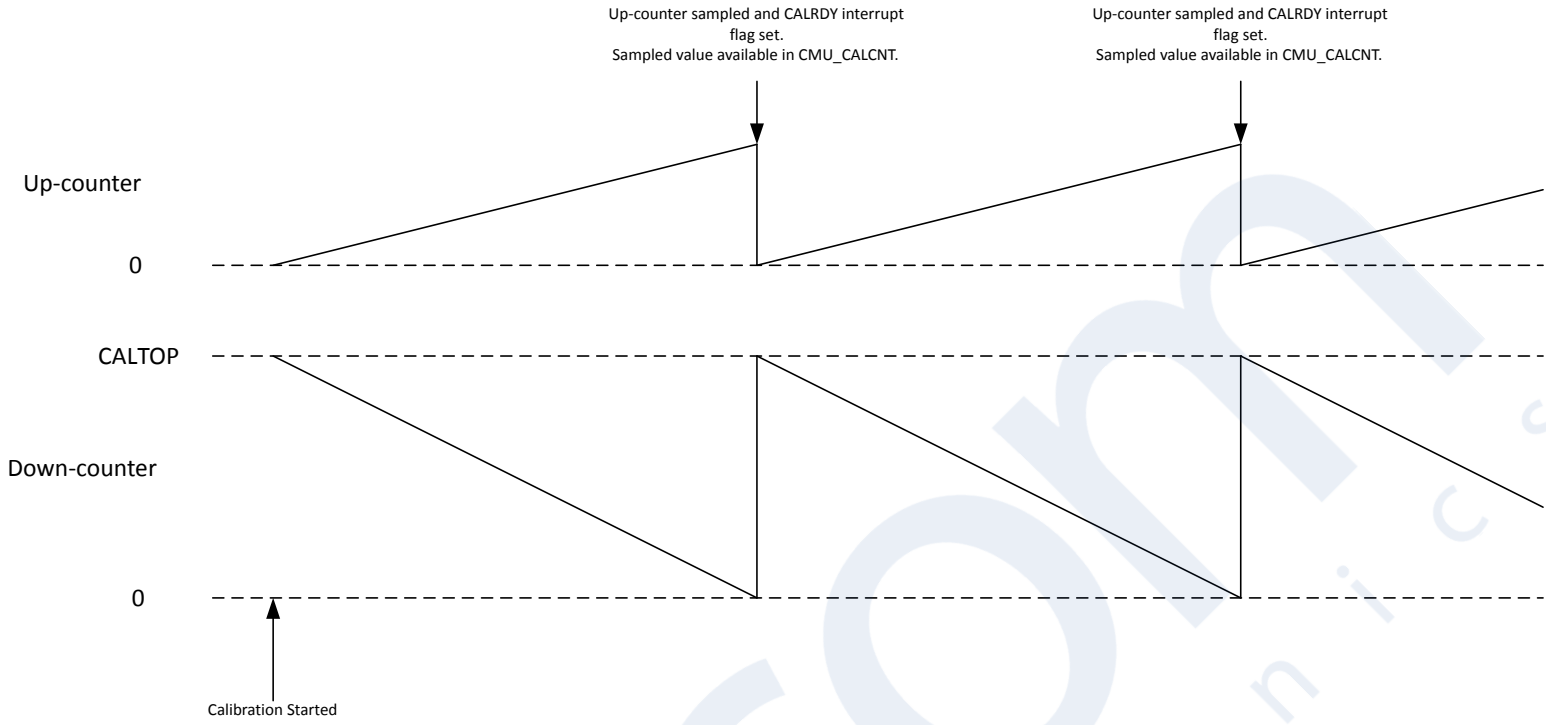

Figure 8.9. Continuous Calibration (CONT=1)

8.3.4 Energy Modes

The availability of oscillators and system clocks depends on the chosen energy mode. By default, the high frequency oscillators and high frequency clocks are available down to EM1 Sleep. From EM2 DeepSleep onwards these oscillators and clocks are normally off, although special cases exist as summarized in [Table 8.1 Oscillator and clock availability in Energy Modes on page 161](#). The CMU figures in [8.3 Functional Description](#) also indicate which oscillators and clocks can be used in what energy modes.

The low frequency oscillators (LFRCO and LFXO) are available in all energy modes except in EM3 Stop when they are off by definition. By default, these oscillators are also off in EM4 Shutoff. The LFXO or LFRCO can be requested in EM4 as needed. The ultra low frequency oscillator (ULFRCO) is on in all energy modes, except for EM4 Shutoff, but it can be requested on in that state as well if needed. The low frequency clocks are in various power domains and therefore their availability not only depends on the chosen clock source, but also on the chosen energy mode as indicated in [Table 8.1 Oscillator and clock availability in Energy Modes on page 161](#).

Table 8.1. Oscillator and clock availability in Energy Modes

	EM0 Active / EM1 Sleep	EM2 DeepSleep	EM3 Stop	EM4 Shutoff
HFRCODPLL	On ¹	Off	Off	Off
HFXO	On ¹	Off	Off	Off
HFRCOEM23	On ¹	On ²	On ²	Off
LFRCO, LFXO	On ¹	On ¹	Off	On ³
ULFRCO	On	On	On	On ³
SYSCLK, HCLK, PCLK, LSPCLK, RHCLK, EM01GRPACLK, EM01GRPCCLK	On ¹	Off	Off	Off
IADCCLK, VDACnCLK	On ¹	On ²	On ²	Off
EM23GRPACLK, WDOGnCLK, SYSRTCCLK, VDACn_REFRESH_CLK, PCNT0CLK	On ¹	On ¹	On ⁴	Off
EM4GRPACLK	On ¹	On ¹	On ⁴	On ³

- 1 Under software control.
- 2 Default off, but kept active if requested by modules.
- 3 Default off, but kept active if used by BURTC.
- 4 On only if ULFRCO is used as clock source.

8.3.5 Clock Output

The CMU has up to three CLKOUTn signals that can be routed to the PRS or GPIO. The selections for CLKOUTn are controlled using the CLKOUTSELn bitfields in CMU_EXPORTCLKCTRL (CLKOUTSEL0 controls CLKOUT0, for example).

The following clocks can be selected for CLKOUTn:

- HCLK and EXPORTCLK. The HCLK is the high frequency clock for AHB. The EXPORTCLK is a prescaled version of SYSCLK as controlled by the PRESC bitfield in the CMU_EXPORTCLKCTRL register.
- The qualified clock from any of the on-chip oscillators. A qualified clock will not have any glitches or skewed duty-cycle during start-up. For the LFXO and HFXO, correct configuration of the TIMEOUT bitfield(s) in LFXO_CFG and HFXO_XTALCFG, respectively is required to guarantee a properly qualified clock.

HCLK will only have a 50-50 duty cycle when HCLKPRESC in CMU_SYSCLKCTRL is DIV1. EXPORTCLK will only be 50-50 duty cycle when the selected division factor is even.

The CLKOUTn signals may be routed to GPIO via the DBUS as CMU.CLKOUTn using controls in the GPIO registers. The required output pins must be enabled in the GPIO_CMU_ROUTEEN register and the pin locations can be configured in the GPIO_CMU_CLKOUTnROUTE registers.

The CLKOUTn signals can also be used as PRS producers (see [13.3.3 Producers](#) for more detail on PRS producers). CLKOUTn signals used as PRS producers may be simultaneously routed to GPIO, but this is not required to use CLKOUTn as a PRS producer.

8.3.6 Clock Input from a Pin

It is possible to configure the CMU to input a clock from the CMU_CLKI0. This clock can be selected to drive SYSCLK and DPLL reference using CMU_SYSCLKCTRL.CLKSEL and CMU_DPLLREFCLKCTRL.CLKSEL respectively. The required input pin locations can be configured in the GPIO_CMU_CLKIN0ROUTE register.

8.3.7 Interrupts

The interrupts generated by the CMU module are combined into one interrupt vector. If CMU interrupts are enabled, an interrupt will be made if one or more of the interrupt flags in CMU_IF and their corresponding bits in CMU_IEN are set.

8.3.8 Protection

It is possible to lock the control and command registers to prevent unintended software writes to critical clock settings. This is controlled by the CMU_LOCK register.

The WDOGCLKCTRL registers are separately locked by CMU_WDOGLOCK register. This is to prevent EM3 Stop mode from disabling the watch dog clocks inadvertently.

In addition to software locks, hardware locks are implemented to prevent metastability. CMU_CALCTRL is locked by hardware when calibration is started by CMU_CALCMD.CALSTART. CMU_DPLLREFCLKCTRL is locked by hardware when DPLL is enabled via DPLL_EN.EN. Because these switches are not glitch-less, clock selection must be configured before enabling the operation and cannot be changed during operation.

8.4 CMU Register Map

The offset register address is relative to the registers base address.

Offset	Name	Type	Description
0x000	CMU_IPVERSION	R	IP Version ID
0x008	CMU_STATUS	RH	Status Register
0x010	CMU_LOCK	W	Configuration Lock Register
0x014	CMU_WDOGLOCK	W	WDOG Configuration Lock Register
0x020	CMU_IF	RWH INTFLAG	Interrupt Flag Register
0x024	CMU_IEN	RW	Interrupt Enable Register
0x050	CMU_CALC_CMD	W	Calibration Command Register
0x054	CMU_CALC_CTRL	RW	Calibration Control Register
0x058	CMU_CALC_CNT	R	Calibration Result Counter Register
0x064	CMU_CLKEN0	RW	Clock Enable Register 0
0x068	CMU_CLKEN1	RW	Clock Enable Register 1
0x070	CMU_SYSCLKCTRL	RW	System Clock Control
0x080	CMU_TRACECLKCTRL	RW	Debug Trace Clock Control
0x090	CMU_EXPORTCLKCTRL	RW	Export Clock Control
0x100	CMU_DPLLREFCLKCTRL	RW	Digital PLL Reference Clock Control
0x120	CMU_EM01GRPACLKCTRL	RW	EM01 Peripheral Group a Clock Control
0x128	CMU_EM01GRPCCLKCTRL	RW	EM01 Peripheral Group C Clock Control
0x140	CMU_EM23GRPACLKCTRL	RW	EM23 Peripheral Group a Clock Control
0x160	CMU_EM4GRPACLKCTRL	RW	EM4 Peripheral Group a Clock Control
0x180	CMU_IADCCLKCTRL	RW	IADC Clock Control
0x200	CMU_WDOG0CLKCTRL	RW	Watchdog0 Clock Control
0x208	CMU_WDOG1CLKCTRL	RW	Watchdog1 Clock Control
0x220	CMU_EUSART0CLKCTRL	RW	EUSART0 Clock Control
0x240	CMU_SYSRTC0CLKCTRL	RW	System RTC0 Clock Control
0x260	CMU_VDAC0CLKCTRL	RW	VDAC0 Clock Control
0x270	CMU_PCNT0CLKCTRL	RW	Pulse Counter 0 Clock Control
0x280	CMU_RADIOCLKCTRL	RW	Radio Clock Control
0x294	CMU_VDAC1CLKCTRL	RW	VDAC1 Clock Control
0x1000	CMU_IPVERSION_SET	R	IP Version ID
0x1008	CMU_STATUS_SET	RH	Status Register
0x1010	CMU_LOCK_SET	W	Configuration Lock Register
0x1014	CMU_WDOGLOCK_SET	W	WDOG Configuration Lock Register
0x1020	CMU_IF_SET	RWH INTFLAG	Interrupt Flag Register
0x1024	CMU_IEN_SET	RW	Interrupt Enable Register
0x1050	CMU_CALC_CMD_SET	W	Calibration Command Register

Offset	Name	Type	Description
0x1054	CMU_CALCTRL_SET	RW	Calibration Control Register
0x1058	CMU_CALCNT_SET	R	Calibration Result Counter Register
0x1064	CMU_CLKEN0_SET	RW	Clock Enable Register 0
0x1068	CMU_CLKEN1_SET	RW	Clock Enable Register 1
0x1070	CMU_SYSCLKCTRL_SET	RW	System Clock Control
0x1080	CMU_TRACECLKCTRL_SET	RW	Debug Trace Clock Control
0x1090	CMU_EXPORTCLKCTRL_SET	RW	Export Clock Control
0x1100	CMU_DPLLREFCLKCTRL_SET	RW	Digital PLL Reference Clock Control
0x1120	CMU_EM01GRPACLKCTRL_SET	RW	EM01 Peripheral Group a Clock Control
0x1128	CMU_EM01GRPCCLKCTRL_SET	RW	EM01 Peripheral Group C Clock Control
0x1140	CMU_EM23GRPACLKCTRL_SET	RW	EM23 Peripheral Group a Clock Control
0x1160	CMU_EM4GRPACLKCTRL_SET	RW	EM4 Peripheral Group a Clock Control
0x1180	CMU_IADCCLKCTRL_SET	RW	IADC Clock Control
0x1200	CMU_WDOG0CLKCTRL_SET	RW	Watchdog0 Clock Control
0x1208	CMU_WDOG1CLKCTRL_SET	RW	Watchdog1 Clock Control
0x1220	CMU_EUSART0CLKCTRL_SET	RW	EUSART0 Clock Control
0x1240	CMU_SYSRTC0CLKCTRL_SET	RW	System RTC0 Clock Control
0x1260	CMU_VDAC0CLKCTRL_SET	RW	VDAC0 Clock Control
0x1270	CMU_PCNT0CLKCTRL_SET	RW	Pulse Counter 0 Clock Control
0x1280	CMU_RADIOCLKCTRL_SET	RW	Radio Clock Control
0x1294	CMU_VDAC1CLKCTRL_SET	RW	VDAC1 Clock Control
0x2000	CMU_IPVERSION_CLR	R	IP Version ID
0x2008	CMU_STATUS_CLR	RH	Status Register
0x2010	CMU_LOCK_CLR	W	Configuration Lock Register
0x2014	CMU_WDOGLOCK_CLR	W	WDOG Configuration Lock Register
0x2020	CMU_IF_CLR	RWH INTFLAG	Interrupt Flag Register
0x2024	CMU_IEN_CLR	RW	Interrupt Enable Register
0x2050	CMU_CALCMD_CLR	W	Calibration Command Register
0x2054	CMU_CALCTRL_CLR	RW	Calibration Control Register
0x2058	CMU_CALCNT_CLR	R	Calibration Result Counter Register
0x2064	CMU_CLKEN0_CLR	RW	Clock Enable Register 0
0x2068	CMU_CLKEN1_CLR	RW	Clock Enable Register 1
0x2070	CMU_SYSCLKCTRL_CLR	RW	System Clock Control
0x2080	CMU_TRACECLKCTRL_CLR	RW	Debug Trace Clock Control
0x2090	CMU_EXPORTCLKCTRL_CLR	RW	Export Clock Control

Offset	Name	Type	Description
0x2100	CMU_DPLLREFCLKCTRL_CLR	RW	Digital PLL Reference Clock Control
0x2120	CMU_EM01GRPACLKCTRL_CLR	RW	EM01 Peripheral Group a Clock Control
0x2128	CMU_EM01GRPCCLKCTRL_CLR	RW	EM01 Peripheral Group C Clock Control
0x2140	CMU_EM23GRPACLKCTRL_CLR	RW	EM23 Peripheral Group a Clock Control
0x2160	CMU_EM4GRPACLKCTRL_CLR	RW	EM4 Peripheral Group a Clock Control
0x2180	CMU_IADCCLKCTRL_CLR	RW	IADC Clock Control
0x2200	CMU_WDOG0CLKCTRL_CLR	RW	Watchdog0 Clock Control
0x2208	CMU_WDOG1CLKCTRL_CLR	RW	Watchdog1 Clock Control
0x2220	CMU_EUSART0CLKCTRL_CLR	RW	EUSART0 Clock Control
0x2240	CMU_SYSRTC0CLKCTRL_CLR	RW	System RTC0 Clock Control
0x2260	CMU_VDAC0CLKCTRL_CLR	RW	VDAC0 Clock Control
0x2270	CMU_PCNT0CLKCTRL_CLR	RW	Pulse Counter 0 Clock Control
0x2280	CMU_RADIOCLKCTRL_CLR	RW	Radio Clock Control
0x2294	CMU_VDAC1CLKCTRL_CLR	RW	VDAC1 Clock Control
0x3000	CMU_IPVERSION_TGL	R	IP Version ID
0x3008	CMU_STATUS_TGL	RH	Status Register
0x3010	CMU_LOCK_TGL	W	Configuration Lock Register
0x3014	CMU_WDOGLOCK_TGL	W	WDOG Configuration Lock Register
0x3020	CMU_IF_TGL	RWH INTFLAG	Interrupt Flag Register
0x3024	CMU_IEN_TGL	RW	Interrupt Enable Register
0x3050	CMU_CALCMD_TGL	W	Calibration Command Register
0x3054	CMU_CALCCTRL_TGL	RW	Calibration Control Register
0x3058	CMU_CALCNT_TGL	R	Calibration Result Counter Register
0x3064	CMU_CLKEN0_TGL	RW	Clock Enable Register 0
0x3068	CMU_CLKEN1_TGL	RW	Clock Enable Register 1
0x3070	CMU_SYSCLKCTRL_TGL	RW	System Clock Control
0x3080	CMU_TRACECLKCTRL_TGL	RW	Debug Trace Clock Control
0x3090	CMU_EXPORTCLKCTRL_TGL	RW	Export Clock Control
0x3100	CMU_DPLLREFCLKCTRL_TGL	RW	Digital PLL Reference Clock Control
0x3120	CMU_EM01GRPACLKCTRL_TGL	RW	EM01 Peripheral Group a Clock Control
0x3128	CMU_EM01GRPCCLKCTRL_TGL	RW	EM01 Peripheral Group C Clock Control
0x3140	CMU_EM23GRPACLKCTRL_TGL	RW	EM23 Peripheral Group a Clock Control
0x3160	CMU_EM4GRPACLKCTRL_TGL	RW	EM4 Peripheral Group a Clock Control

Offset	Name	Type	Description
0x3180	CMU_IADCCLKCTRL_TGL	RW	IADC Clock Control
0x3200	CMU_WDOG0CLKCTRL_TGL	RW	Watchdog0 Clock Control
0x3208	CMU_WDOG1CLKCTRL_TGL	RW	Watchdog1 Clock Control
0x3220	CMU_EUSART0CLKCTRL_TGL	RW	EUSART0 Clock Control
0x3240	CMU_SYSRTC0CLKCTRL_TGL	RW	System RTC0 Clock Control
0x3260	CMU_VDAC0CLKCTRL_TGL	RW	VDAC0 Clock Control
0x3270	CMU_PCNT0CLKCTRL_TGL	RW	Pulse Counter 0 Clock Control
0x3280	CMU_RADIOCLKCTRL_TGL	RW	Radio Clock Control
0x3294	CMU_VDAC1CLKCTRL_TGL	RW	VDAC1 Clock Control

8.5 CMU Register Description

8.5.1 CMU_IPVERSION - IP Version ID

Offset	Bit Position																															
0x000	31	30	29	28	27	26	25	24	23	22	21	20	19	18	17	16	15	14	13	12	11	10	9	8	7	6	5	4	3	2	1	0
Reset																0x3																
Access																R																
Name																IPVERSION																

Bit	Name	Reset	Access	Description
31:0	IPVERSION	0x3	R	IP Version ID

8.5.2 CMU_STATUS - Status Register

Offset	Bit Position																															
0x008	31	30	29	28	27	26	25	24	23	22	21	20	19	18	17	16	15	14	13	12	11	10	9	8	7	6	5	4	3	2	1	0
Reset	0x0	0x0																														0x0
Access	R	R																														R
Name	LOCK	WDOGLOCK																														CALRDY

Bit	Name	Reset	Access	Description
31	LOCK	0x0	R	Configuration Lock Status Indicates the current status of configuration lock
	Value	Mode		Description
	0	UNLOCKED		Configuration lock is unlocked
	1	LOCKED		Configuration lock is locked
30	WDOGLOCK	0x0	R	Configuration Lock Status for WDOG Indicates the current status of WDOG configuration lock
	Value	Mode		Description
	0	UNLOCKED		WDOG configuration lock is unlocked
	1	LOCKED		WDOG configuration lock is locked
29:1	<i>Reserved</i>	<i>To ensure compatibility with future devices, always write Reserved bits to their reset value, unless otherwise stated. More information in 1.2 Conventions</i>		
0	CALRDY	0x0	R	Calibration Ready Calibration is Ready (0 when calibration is ongoing).

8.5.3 CMU_LOCK - Configuration Lock Register

Offset	Bit Position																															
0x010	31	30	29	28	27	26	25	24	23	22	21	20	19	18	17	16	15	14	13	12	11	10	9	8	7	6	5	4	3	2	1	0
Reset																	0x93F7															
Access																	W															
Name																	LOCKKEY															

Bit	Name	Reset	Access	Description
31:16	Reserved	To ensure compatibility with future devices, always write Reserved bits to their reset value, unless otherwise stated. More information in 1.2 Conventions		
15:0	LOCKKEY	0x93F7	W	Configuration Lock Key Write any other value than the unlock code to lock registers from editing. Write the unlock code to unlock.
	Value	Mode	Description	
	37879	UNLOCK	Write this value to unlock	

8.5.4 CMU_WDOGLOCK - WDOG Configuration Lock Register

Offset	Bit Position																															
0x014	31	30	29	28	27	26	25	24	23	22	21	20	19	18	17	16	15	14	13	12	11	10	9	8	7	6	5	4	3	2	1	0
Reset																	0x5257															
Access																	W															
Name																	LOCKKEY															

Bit	Name	Reset	Access	Description
31:16	Reserved	To ensure compatibility with future devices, always write Reserved bits to their reset value, unless otherwise stated. More information in 1.2 Conventions		
15:0	LOCKKEY	0x5257	W	Configuration Lock Key Write any other value than the unlock code to lock registers from editing. Write the unlock code to unlock.
	Value	Mode	Description	
	37879	UNLOCK	Write this value to unlock	

8.5.5 CMU_IF - Interrupt Flag Register

Offset	Bit Position																															
0x020	31	30	29	28	27	26	25	24	23	22	21	20	19	18	17	16	15	14	13	12	11	10	9	8	7	6	5	4	3	2	1	0
Reset																											0x0	0x0				
Access																											RW	RW				
Name																											CALOF	CALRDY				

Bit	Name	Reset	Access	Description
31:2	<i>Reserved</i>	<i>To ensure compatibility with future devices, always write Reserved bits to their reset value, unless otherwise stated. More information in 1.2 Conventions</i>		
1	CALOF	0x0	RW	Calibration Overflow Interrupt Flag Set when calibration overflow has occurred (i.e. if a new calibration completes before CMU_CALSTATUS has been read)
0	CALRDY	0x0	RW	Calibration Ready Interrupt Flag Set when calibration is completed

8.5.6 CMU_IEN - Interrupt Enable Register

Offset	Bit Position																															
0x024	31	30	29	28	27	26	25	24	23	22	21	20	19	18	17	16	15	14	13	12	11	10	9	8	7	6	5	4	3	2	1	0
Reset																											0x0	0x0				
Access																											RW	RW				
Name																											CALOF	CALRDY				

Bit	Name	Reset	Access	Description
31:2	<i>Reserved</i>	<i>To ensure compatibility with future devices, always write Reserved bits to their reset value, unless otherwise stated. More information in 1.2 Conventions</i>		
1	CALOF	0x0	RW	Calibration Overflow Interrupt Enable Enable/disable CALOF interrupt
0	CALRDY	0x0	RW	Calibration Ready Interrupt Enable Enable/disable CALRDY interrupt

8.5.7 CMU_CALCMD - Calibration Command Register

Offset	Bit Position																															
0x050	31	30	29	28	27	26	25	24	23	22	21	20	19	18	17	16	15	14	13	12	11	10	9	8	7	6	5	4	3	2	1	0
Reset																															0x0	0x0
Access																															W(nB)	W(nB)
Name																															CALSTOP	CALSTART

Bit	Name	Reset	Access	Description
31:2	<i>Reserved</i>	<i>To ensure compatibility with future devices, always write Reserved bits to their reset value, unless otherwise stated. More information in 1.2 Conventions</i>		
1	CALSTOP	0x0	W(nB)	Calibration Stop Stops the calibration counters.
0	CALSTART	0x0	W(nB)	Calibration Start Starts the calibration, effectively loading the CMU_CALCTRL.CALCNT into the down-counter and start decrementing.

8.5.8 CMU_CALCTRL - Calibration Control Register

Offset	Bit Position																																						
0x054	31	30	29	28	27	26	25	24	23	22	21	20	19	18	17	16	15	14	13	12	11	10	9	8	7	6	5	4	3	2	1	0							
Reset	0x0			0x0			0x0															0x0																	
Access	RW			RW			RW															RW																	
Name	DOWNSEL			UPSEL			CONT																		CALTOP														

Bit	Name	Reset	Access	Description
31:28	DOWNSEL	0x0	RW	Calibration Down-counter Select Selects clock source for the calibration down-counter. Changing this while calibration is running results in bus fault..
	Value	Mode		Description
	0	DISABLED		Down-counter is not clocked
	1	HCLK		HCLK is clocking down-counter
	2	PRS		PRS CMU_CALDN consumer is clocking down-counter
	3	HFXO		HFXO is clocking down-counter
	4	LFXO		LFXO is clocking down-counter
	5	HFRCODPLL		HFRCODPLL is clocking down-counter
	6	HFRCOEM23		HFRCOEM23 is clocking down-counter
	9	FSRCO		FSRCO is clocking down-counter
	10	LFRCO		LFRCO is clocking down-counter
	11	ULFRCO		ULFRCO is clocking down-counter
27:24	UPSEL	0x0	RW	Calibration Up-counter Select Selects clock source for the calibration up-counter. Changing this while calibration is running results in bus fault.
	Value	Mode		Description
	0	DISABLED		Up-counter is not clocked
	1	PRS		PRS CMU_CALUP consumer is clocking up-counter
	2	HFXO		HFXO is clocking up-counter
	3	LFXO		LFXO is clocking up-counter
	4	HFRCODPLL		HFRCODPLL is clocking up-counter
	5	HFRCOEM23		HFRCOEM23 is clocking up-counter
	8	FSRCO		FSRCO is clocking up-counter
	9	LFRCO		LFRCO is clocking up-counter
	10	ULFRCO		ULFRCO is clocking up-counter
23	CONT	0x0	RW	Continuous Calibration

Bit	Name	Reset	Access	Description
				Set this bit to enable continuous calibration. Changing this while calibration is running results in bus fault.
22:20	Reserved	<i>To ensure compatibility with future devices, always write Reserved bits to their reset value, unless otherwise stated. More information in 1.2 Conventions</i>		
19:0	CALTOP	0x0	RW	Calibration Counter Top Value Write top value before calibration. Changing this while calibration is running results in bus fault.

8.5.9 CMU_CALCNT - Calibration Result Counter Register

Offset	Bit Position																															
0x058	31	30	29	28	27	26	25	24	23	22	21	20	19	18	17	16	15	14	13	12	11	10	9	8	7	6	5	4	3	2	1	0
Reset											0x0																					
Access											R																					
Name											CALCNT																					

Bit	Name	Reset	Access	Description
31:20	Reserved	<i>To ensure compatibility with future devices, always write Reserved bits to their reset value, unless otherwise stated. More information in 1.2 Conventions</i>		
19:0	CALCNT	0x0	R	Calibration Result Counter Value Read calibration result when Calibration Ready flag has been set.

8.5.10 CMU_CLKEN0 - Clock Enable Register 0

Offset	Bit Position																															
0x064	31	30	29	28	27	26	25	24	23	22	21	20	19	18	17	16	15	14	13	12	11	10	9	8	7	6	5	4	3	2	1	0
Reset	0x0	0x0	0x0	0x0	0x0	0x0		0x0	0x0	0x0	0x0	0x0	0x0	0x0	0x0	0x0	0x0	0x0	0x0	0x0	0x0	0x0	0x0	0x0	0x0	0x0	0x0	0x0	0x0	0x0	0x0	0x0
Access	RW	RW	RW	RW	RW	RW		RW	RW	RW	RW	RW	RW	RW	RW	RW	RW	RW	RW	RW	RW	RW	RW	RW	RW	RW	RW	RW	RW	RW	RW	RW
Name	DCDC	SYSRTC0	BURTC	BURAM	PRS	GPIO		ULFRCO	LFXO	LFRCO	FSRCO	HFXO0	HFRCOEM23	HFRCO0	DPLL0	SYSCFG	I2C1	I2C0	WDOG0	LETIMER0	AMUXCP0	IADC0	USART0	TIMER4	TIMER3	TIMER2	TIMER1	TIMER0	GPCRC	RADIOAES	LDMAXBAR	LDMA

Bit	Name	Reset	Access	Description
31	DCDC	0x0	RW	Enable Bus Clock Enables module PCLK/HCLK
30	SYSRTC0	0x0	RW	Enable Bus Clock Enables module PCLK/HCLK
29	BURTC	0x0	RW	Enable Bus Clock Enables module PCLK/HCLK
28	BURAM	0x0	RW	Enable Bus Clock Enables module PCLK/HCLK
27	PRS	0x0	RW	Enable Bus Clock Enables module PCLK/HCLK
26	GPIO	0x0	RW	Enable Bus Clock Enables module PCLK/HCLK
25	<i>Reserved</i>	<i>To ensure compatibility with future devices, always write Reserved bits to their reset value, unless otherwise stated. More information in 1.2 Conventions</i>		
24	ULFRCO	0x0	RW	Enable Bus Clock Enables module PCLK/HCLK
23	LFXO	0x0	RW	Enable Bus Clock Enables module PCLK/HCLK
22	LFRCO	0x0	RW	Enable Bus Clock Enables module PCLK/HCLK
21	FSRCO	0x0	RW	Enable Bus Clock Enables module PCLK/HCLK
20	HFXO0	0x0	RW	Enable Bus Clock Enables module PCLK/HCLK
19	HFRCOEM23	0x0	RW	Enable Bus Clock Enables module PCLK/HCLK
18	HFRCO0	0x0	RW	Enable Bus Clock Enables HFRCODPLL/HFRCO0 module PCLK/HCLK

Bit	Name	Reset	Access	Description
17	DPLL0	0x0	RW	Enable Bus Clock Enables module PCLK/HCLK
16	SYSCFG	0x0	RW	Enable Bus Clock Enables module PCLK/HCLK
15	I2C1	0x0	RW	Enable Bus Clock Enables module PCLK/HCLK
14	I2C0	0x0	RW	Enable Bus Clock Enables module PCLK/HCLK
13	WDOG0	0x0	RW	Enable Bus Clock Enables module PCLK/HCLK
12	LETIMER0	0x0	RW	Enable Bus Clock Enables module PCLK/HCLK
11	AMUXCP0	0x0	RW	Enable Bus Clock Enables module PCLK/HCLK
10	IADC0	0x0	RW	Enable Bus Clock Enables module PCLK/HCLK
9	USART0	0x0	RW	Enable Bus Clock Enables module PCLK/HCLK
8	TIMER4	0x0	RW	Enable Bus Clock Enables module PCLK/HCLK
7	TIMER3	0x0	RW	Enable Bus Clock Enables module PCLK/HCLK
6	TIMER2	0x0	RW	Enable Bus Clock Enables module PCLK/HCLK
5	TIMER1	0x0	RW	Enable Bus Clock Enables module PCLK/HCLK
4	TIMER0	0x0	RW	Enable Bus Clock Enables module PCLK/HCLK
3	GPCRC	0x0	RW	Enable Bus Clock Enables module PCLK/HCLK
2	RADIOAES	0x0	RW	Enable Bus Clock Enables module PCLK/HCLK
1	LDMAXBAR	0x0	RW	Enable Bus Clock Enables module PCLK/HCLK
0	LDMA	0x0	RW	Enable Bus Clock Enables module PCLK/HCLK

8.5.11 CMU_CLKEN1 - Clock Enable Register 1

Offset	Bit Position																																
0x068	31	30	29	28	27	26	25	24	23	22	21	20	19	18	17	16	15	14	13	12	11	10	9	8	7	6	5	4	3	2	1	0	
Reset		0x0	0x0	0x0	0x0	0x0	0x0		0x0	0x0	0x0	0x0	0x0	0x0	0x0	0x0	0x0	0x0	0x0		0x0	0x0	0x0	0x0	0x0	0x0	0x0	0x0	0x0	0x0	0x0	0x0	0x0
Access		RW	RW	RW	RW	RW	RW		RW	RW	RW	RW	RW	RW	RW	RW	RW	RW	RW		RW	RW	RW	RW	RW	RW	RW	RW	RW	RW	RW	RW	RW
Name		MVP	VDAC1	ECAIFADC	DMEM	RFECA1	RFECA0		EUSART1	EUSART0	PCNT0	VDAC0	ACMP1	ACMP0	WDOG1	MSC	ICACHE0	SMU	KEYSCAN		BUFC	SEMAILBOXHOST	RFMAILBOX	HOSTMAILBOX	RFSCRATCHPAD	SYNTH	RAC	PROTIMER	FRC	RFRC	MODEM	AGC	

Bit	Name	Reset	Access	Description
31	<i>Reserved</i>			<i>To ensure compatibility with future devices, always write Reserved bits to their reset value, unless otherwise stated. More information in 1.2 Conventions</i>
30	MVP Enables module PCLK/HCLK	0x0	RW	Enable Bus Clock
29	VDAC1 Enables module PCLK/HCLK	0x0	RW	Enable Bus Clock
28	ECAIFADC Enables module PCLK/HCLK	0x0	RW	Enable Bus Clock
27	DMEM Enables module PCLK/HCLK	0x0	RW	Enable Bus Clock
26	RFECA1 Enables module PCLK/HCLK	0x0	RW	Enable Bus Clock
25	RFECA0 Enables module PCLK/HCLK	0x0	RW	Enable Bus Clock
24	<i>Reserved</i>			<i>To ensure compatibility with future devices, always write Reserved bits to their reset value, unless otherwise stated. More information in 1.2 Conventions</i>
23	EUSART1 Enables module PCLK/HCLK	0x0	RW	Enable Bus Clock
22	EUSART0 Enables module PCLK/HCLK	0x0	RW	Enable Bus Clock
21	PCNT0 Enables module PCLK/HCLK	0x0	RW	Enable Bus Clock
20	VDAC0 Enables module PCLK/HCLK	0x0	RW	Enable Bus Clock
19	ACMP1 Enables module PCLK/HCLK	0x0	RW	Enable Bus Clock
18	ACMP0	0x0	RW	Enable Bus Clock

Bit	Name	Reset	Access	Description
				Enables module PCLK/HCLK
17	WDOG1	0x0	RW	Enable Bus Clock
				Enables module PCLK/HCLK
16	MSC	0x0	RW	Enable Bus Clock
				Enables module PCLK/HCLK
15	ICACHE0	0x0	RW	Enable Bus Clock
				Enables module PCLK/HCLK
14	SMU	0x0	RW	Enable Bus Clock
				Enables module PCLK/HCLK
13	KEYSCAN	0x0	RW	Enable Bus Clock
				Enables module PCLK/HCLK
12	<i>Reserved</i>	<i>To ensure compatibility with future devices, always write Reserved bits to their reset value, unless otherwise stated. More information in 1.2 Conventions</i>		
11	BUFC	0x0	RW	Enable Bus Clock
				Enables module PCLK/HCLK
10	SEMAILBOXHOST	0x0	RW	Enable Bus Clock
				Enables module PCLK/HCLK
9	RFMAILBOX	0x0	RW	Enable Bus Clock
				Enables module PCLK/HCLK
8	HOSTMAILBOX	0x0	RW	Enable Bus Clock
				Enables module PCLK/HCLK
7	RFSCRATCHPAD	0x0	RW	Enable Bus Clock
				Enables module PCLK/HCLK
6	SYNTH	0x0	RW	Enable Bus Clock
				Enables module PCLK/HCLK
5	RAC	0x0	RW	Enable Bus Clock
				Enables module PCLK/HCLK
4	PROTIMER	0x0	RW	Enable Bus Clock
				Enables module PCLK/HCLK
3	FRC	0x0	RW	Enable Bus Clock
				Enables module PCLK/HCLK
2	RFCRC	0x0	RW	Enable Bus Clock
				Enables module PCLK/HCLK
1	MODEM	0x0	RW	Enable Bus Clock
				Enables module PCLK/HCLK
0	AGC	0x0	RW	Enable Bus Clock
				Enables module PCLK/HCLK

8.5.12 CMU_SYCLKCTRL - System Clock Control

Offset	Bit Position																															
0x070	31	30	29	28	27	26	25	24	23	22	21	20	19	18	17	16	15	14	13	12	11	10	9	8	7	6	5	4	3	2	1	0
Reset																0x0	0x0				0x0											0x1
Access																RW	RW				RW											RW
Name																RHCLKPRESC	HCLKPRESC				PCLKPRESC											CLKSEL

Bit	Name	Reset	Access	Description
31:17	<i>Reserved</i>	<i>To ensure compatibility with future devices, always write Reserved bits to their reset value, unless otherwise stated. More information in 1.2 Conventions</i>		
16	RHCLKPRESC	0x0	RW	Radio HCLK Prescaler Specifies the clock divider for Radio HCLK
	Value	Mode	Description	
	0	DIV1	Radio HCLK is SYSCLK divided by 1	
	1	DIV2	Radio HCLK is SYSCLK divided by 2	
15:12	HCLKPRESC	0x0	RW	HCLK Prescaler Specifies the clock divider for HCLK
	Value	Mode	Description	
	0	DIV1	HCLK is SYSCLK divided by 1	
	1	DIV2	HCLK is SYSCLK divided by 2	
	3	DIV4	HCLK is SYSCLK divided by 4	
	7	DIV8	HCLK is SYSCLK divided by 8	
	15	DIV16	HCLK is SYSCLK divided by 16	
11	<i>Reserved</i>	<i>To ensure compatibility with future devices, always write Reserved bits to their reset value, unless otherwise stated. More information in 1.2 Conventions</i>		
10	PCLKPRESC	0x0	RW	PCLK Prescaler Specifies the clock divider for PCLK
	Value	Mode	Description	
	0	DIV1	PCLK is HCLK divided by 1	
	1	DIV2	PCLK is HCLK divided by 2	
9:3	<i>Reserved</i>	<i>To ensure compatibility with future devices, always write Reserved bits to their reset value, unless otherwise stated. More information in 1.2 Conventions</i>		
2:0	CLKSEL	0x1	RW	Clock Select Selects the clock source for SYSCLK.

Bit	Name	Reset	Access	Description
	Value	Mode		Description
1		FSRCO		FSRCO is clocking SYSCLK
2		HFRCODPLL		HFRCODPLL is clocking SYSCLK
3		HFXO		HFXO is clocking SYSCLK
4		CLKIN0		CLKIN0 is clocking SYSCLK

8.5.13 CMU_TRACECLKCTRL - Debug Trace Clock Control

Offset	Bit Position																															
0x080	31	30	29	28	27	26	25	24	23	22	21	20	19	18	17	16	15	14	13	12	11	10	9	8	7	6	5	4	3	2	1	0
Reset																									0x0				0x1			
Access																									RW				RW			
Name																									PRESC				CLKSEL			

Bit	Name	Reset	Access	Description
31:6	<i>Reserved</i>	<i>To ensure compatibility with future devices, always write Reserved bits to their reset value, unless otherwise stated. More information in 1.2 Conventions</i>		
5:4	PRESC	0x0	RW	TRACECLK Prescaler Clock prescaler for the TRACECLKIN of TPIU. Changing this while the TRCENA bit is set in the ARM M33 Debug Exception and Monitor Control Register (DEMCR) will result in a bus fault.
	Value	Mode		Description
	0	DIV1		TRACECLK is SYSCLK divided by 1
	1	DIV2		TRACECLK is SYSCLK divided by 2
	2	DIV3		TRACECLK is SYSCLK divided by 3
	3	DIV4		TRACECLK is SYSCLK divided by 4
3:2	<i>Reserved</i>	<i>To ensure compatibility with future devices, always write Reserved bits to their reset value, unless otherwise stated. More information in 1.2 Conventions</i>		
1:0	CLKSEL	0x1	RW	Clock Select Selects clock source for the TRACECLKIN of TPIU. Changing this while the TRCENA bit is set in the ARM M33 Debug Exception and Monitor Control Register (DEMCR) will result in a bus fault.
	Value	Mode		Description
	0	DISABLE		TRACE clock is disable
	1	SYSCLK		SYSCLK is driving TRACE
	2	HFRCOEM23		HFRCOEM23 is driving TRACE
	3	HFRCODPLLRT		HFRCODPLLRT is driving TRACE

8.5.14 CMU_EXPORTCLKCTRL - Export Clock Control

Offset	Bit Position																															
0x090	31	30	29	28	27	26	25	24	23	22	21	20	19	18	17	16	15	14	13	12	11	10	9	8	7	6	5	4	3	2	1	0
Reset					0x0								0x0								0x0											
Access					RW								RW								RW											
Name					PRESC								CLKOUTSEL2								CLKOUTSEL1								CLKOUTSELO			

Bit	Name	Reset	Access	Description
31:29	<i>Reserved</i>	<i>To ensure compatibility with future devices, always write Reserved bits to their reset value, unless otherwise stated. More information in 1.2 Conventions</i>		
28:24	PRESC	0x0	RW	EXPORTCLK Prescaler Specifies the clock divider for EXPORTCLK (relative to SYSCLK).
23:20	<i>Reserved</i>	<i>To ensure compatibility with future devices, always write Reserved bits to their reset value, unless otherwise stated. More information in 1.2 Conventions</i>		
19:16	CLKOUTSEL2	0x0	RW	Clock Output Select 2 Controls the clock output 2 multiplexer.
	Value	Mode	Description	
	0	DISABLED	CLKOUT2 is not clocked	
	1	HCLK	HCLK is clocking CLKOUT2	
	2	HFEXPCLK	EXPORTCLK is clocking CLKOUT2	
	3	ULFRCO	ULFRCO is clocking CLKOUT2	
	4	LFRCO	LFRCO is clocking CLKOUT2	
	5	LFXO	LFXO is clocking CLKOUT2	
	6	HFRCODPLL	HFRCODPLL is clocking CLKOUT2	
	7	HFXO	HFXO is clocking CLKOUT2	
	8	FSRCO	FSRCO is clocking CLKOUT2	
	9	HFRCOEM23	HFRCOEM23 is clocking CLKOUT2	
15:12	<i>Reserved</i>	<i>To ensure compatibility with future devices, always write Reserved bits to their reset value, unless otherwise stated. More information in 1.2 Conventions</i>		
11:8	CLKOUTSEL1	0x0	RW	Clock Output Select 1 Controls the clock output 1 multiplexer.
	Value	Mode	Description	
	0	DISABLED	CLKOUT1 is not clocked	
	1	HCLK	HCLK is clocking CLKOUT1	
	2	HFEXPCLK	EXPORTCLK is clocking CLKOUT1	

Bit	Name	Reset	Access	Description
3		ULFRCO		ULFRCO is clocking CLKOUT1
4		LFRCO		LFRCO is clocking CLKOUT1
5		LF XO		LF XO is clocking CLKOUT1
6		HFR COD PLL		HFR COD PLL is clocking CLKOUT1
7		HFXO		HFXO is clocking CLKOUT1
8		FSR CO		FSR CO is clocking CLKOUT1
9		HFR CO EM23		HFR CO EM23 is clocking CLKOUT1
7:4	<i>Reserved</i>	<i>To ensure compatibility with future devices, always write Reserved bits to their reset value, unless otherwise stated. More information in 1.2 Conventions</i>		
3:0	CLKOUTSEL0	0x0	RW	Clock Output Select 0 Controls the clock output 0 multiplexer.
	Value	Mode		Description
	0	DISABLED		CLKOUT0 is not clocked
	1	HCLK		HCLK is clocking CLKOUT0
	2	HFEXPCLK		EXPORTCLK is clocking CLKOUT0
	3	ULFRCO		ULFRCO is clocking CLKOUT0
	4	LFRCO		LFRCO is clocking CLKOUT0
	5	LF XO		LF XO is clocking CLKOUT0
	6	HFR COD PLL		HFR COD PLL is clocking CLKOUT0
	7	HFXO		HFXO is clocking CLKOUT0
	8	FSR CO		FSR CO is clocking CLKOUT0
	9	HFR CO EM23		HFR CO EM23 is clocking CLKOUT0

8.5.15 CMU_DPLLREFCLKCTRL - Digital PLL Reference Clock Control

Offset	Bit Position																															
0x100	31	30	29	28	27	26	25	24	23	22	21	20	19	18	17	16	15	14	13	12	11	10	9	8	7	6	5	4	3	2	1	0
Reset																															1	0x0
Access																															RW	
Name																															CLKSEL	

Bit	Name	Reset	Access	Description
31:2	<i>Reserved</i>	<i>To ensure compatibility with future devices, always write Reserved bits to their reset value, unless otherwise stated. More information in 1.2 Conventions</i>		
1:0	CLKSEL	0x0	RW	Clock Select Selects the clock source for DPLL reference. Changing this while DPLL is enabled results in bus fault.
	Value	Mode	Description	
	0	DISABLED	DPLLREFCLK is not clocked	
	1	HFXO	HFXO is clocking DPLLREFCLK	
	2	LFXO	LFXO is clocking DPLLREFCLK	
	3	CLKIN0	CLKIN0 is clocking DPLLREFCLK	

8.5.16 CMU_EM01GRPACLKCTRL - EM01 Peripheral Group a Clock Control

Offset	Bit Position																															
0x120	31	30	29	28	27	26	25	24	23	22	21	20	19	18	17	16	15	14	13	12	11	10	9	8	7	6	5	4	3	2	1	0
Reset																											CLKSEL	0x1				
Access																											CLKSEL	RW				
Name																											CLKSEL					

Bit	Name	Reset	Access	Description
31:3	<i>Reserved</i>	<i>To ensure compatibility with future devices, always write Reserved bits to their reset value, unless otherwise stated. More information in 1.2 Conventions</i>		
2:0	CLKSEL	0x1	RW	Clock Select Selects the clock source for EM01 Group A Clock.
	Value	Mode	Description	
	1	HFRCODPLL	HFRCODPLL is clocking EM01GRPACLK	
	2	HFXO	HFXO is clocking EM01GRPACLK	
	3	FSRCO	FSRCO is clocking EM01GRPACLK	
	4	HFRCOEM23	HFRCOEM23 is clocking EM01GRPACLK	
	5	HFRCODPLLRT	HFRCODPLL (retimed) is clocking EM01GRPACLK. Check with datasheet for frequency limitation when using retiming with voltage scaling.	
	6	HFXORT	HFXO (retimed) is clocking EM01GRPACLK. Check with data-sheet for frequency limitation when using retiming with voltage scaling.	

8.5.17 CMU_EM01GRPCCLKCTRL - EM01 Peripheral Group C Clock Control

Offset	Bit Position																															
0x128	31	30	29	28	27	26	25	24	23	22	21	20	19	18	17	16	15	14	13	12	11	10	9	8	7	6	5	4	3	2	1	0
Reset																											CLKSEL	0x1				
Access																											CLKSEL	RW				
Name																											CLKSEL					

Bit	Name	Reset	Access	Description
31:3	<i>Reserved</i>	<i>To ensure compatibility with future devices, always write Reserved bits to their reset value, unless otherwise stated. More information in 1.2 Conventions</i>		
2:0	CLKSEL	0x1	RW	Clock Select Selects the clock source for EM01 Group C Clock.
	Value	Mode	Description	
	1	HFRCODPLL	HFRCODPLL is clocking EM01GRPCCLK	
	2	HFXO	HFXO is clocking EM01GRPCCLK	
	3	FSRCO	FSRCO is clocking EM01GRPCCLK	
	4	HFRCOEM23	HFRCOEM23 is clocking EM01GRPCCLK	
	5	HFRCODPLLRT	HFRCODPLL (retimed) is clocking EM01GRPCCLK. Check with datasheet for frequency limitation when using retiming with voltage scaling.	
	6	HFXORT	HFXO (retimed) is clocking EM01GRPCCLK. Check with datasheet for frequency limitation when using retiming with voltage scaling.	

8.5.18 CMU_EM23GRPACLKCTRL - EM23 Peripheral Group a Clock Control

Offset	Bit Position																															
0x140	31	30	29	28	27	26	25	24	23	22	21	20	19	18	17	16	15	14	13	12	11	10	9	8	7	6	5	4	3	2	1	0
Reset																															1	0x1
Access																															RW	
Name																															CLKSEL	

Bit	Name	Reset	Access	Description
31:2	<i>Reserved</i>	<i>To ensure compatibility with future devices, always write Reserved bits to their reset value, unless otherwise stated. More information in 1.2 Conventions</i>		
1:0	CLKSEL	0x1	RW	Clock Select Selects the clock source for EM23 Group A Clock.
	Value	Mode	Description	
	1	LFRCO	LFRCO is clocking EM23GRPACLK	
	2	LFXO	LFXO is clocking EM23GRPACLK	
	3	ULFRCO	ULFRCO is clocking EM23GRPACLK	

8.5.19 CMU_EM4GRPACLKCTRL - EM4 Peripheral Group a Clock Control

Offset	Bit Position																															
0x160	31	30	29	28	27	26	25	24	23	22	21	20	19	18	17	16	15	14	13	12	11	10	9	8	7	6	5	4	3	2	1	0
Reset																															1	0x1
Access																															RW	
Name																															CLKSEL	

Bit	Name	Reset	Access	Description
31:2	<i>Reserved</i>	<i>To ensure compatibility with future devices, always write Reserved bits to their reset value, unless otherwise stated. More information in 1.2 Conventions</i>		
1:0	CLKSEL	0x1	RW	Clock Select Selects the clock source for EM4 Group A Clock.
	Value	Mode	Description	
	1	LFRCO	LFRCO is clocking EM4GRPACLK	
	2	LFXO	LFXO is clocking EM4GRPACLK	
	3	ULFRCO	ULFRCO is clocking EM4GRPACLK	

8.5.20 CMU_IADCCLKCTRL - IADC Clock Control

Offset	Bit Position																															
0x180	31	30	29	28	27	26	25	24	23	22	21	20	19	18	17	16	15	14	13	12	11	10	9	8	7	6	5	4	3	2	1	0
Reset																															0x1	
Access																															RW	
Name																															CLKSEL	

Bit	Name	Reset	Access	Description
31:2	<i>Reserved</i>	<i>To ensure compatibility with future devices, always write Reserved bits to their reset value, unless otherwise stated. More information in 1.2 Conventions</i>		
1:0	CLKSEL	0x1	RW	Clock Select Selects the clock source for for IADC. EM01GRPACLK should never be selected as clock source for IADC when disabling the EM01GRACLK (e.g. because of EM23 entry).
	Value	Mode	Description	
	1	EM01GRPACLK	EM01GRPACLK is clocking IADCCLK	
	2	FSRCO	FSRCO is clocking IADCCLK	
	3	HFRCOEM23	HFRCOEM23 is clocking IADCCLK	

8.5.21 CMU_WDOG0CLKCTRL - Watchdog0 Clock Control

Offset	Bit Position																															
0x200	31	30	29	28	27	26	25	24	23	22	21	20	19	18	17	16	15	14	13	12	11	10	9	8	7	6	5	4	3	2	1	0
Reset																															0x1	
Access																															RW	
Name																															CLKSEL	

Bit	Name	Reset	Access	Description
31:3	<i>Reserved</i>	<i>To ensure compatibility with future devices, always write Reserved bits to their reset value, unless otherwise stated. More information in 1.2 Conventions</i>		
2:0	CLKSEL	0x1	RW	Clock Select Selects the clock source for WDOG0.
	Value	Mode	Description	
	1	LFRCO	LFRCO is clocking WDOG0CLK	
	2	LFXO	LFXO is clocking WDOG0CLK	
	3	ULFRCO	ULFRCO is clocking WDOG0CLK	
	4	HCLKDIV1024	HCLKDIV1024 is clocking WDOG0CLK	

8.5.22 CMU_WDOG1CLKCTRL - Watchdog1 Clock Control

Offset	Bit Position																															
0x208	31	30	29	28	27	26	25	24	23	22	21	20	19	18	17	16	15	14	13	12	11	10	9	8	7	6	5	4	3	2	1	0
Reset																	0x1															
Access																	RW															
Name																	CLKSEL															

Bit	Name	Reset	Access	Description
31:3	<i>Reserved</i>	<i>To ensure compatibility with future devices, always write Reserved bits to their reset value, unless otherwise stated. More information in 1.2 Conventions</i>		
2:0	CLKSEL	0x1	RW	Clock Select Selects the clock source for WDOG1.
	Value	Mode	Description	
	1	LFRCO	LFRCO is clocking WDOG0CLK	
	2	LFXO	LFXO is clocking WDOG0CLK	
	3	ULFRCO	ULFRCO is clocking WDOG0CLK	
	4	HCLKDIV1024	HCLKDIV1024 is clocking WDOG0CLK	

8.5.23 CMU_EUSART0CLKCTRL - EUSART0 Clock Control

Offset	Bit Position																															
0x220	31	30	29	28	27	26	25	24	23	22	21	20	19	18	17	16	15	14	13	12	11	10	9	8	7	6	5	4	3	2	1	0
Reset																											CLKSEL		0x1			
Access																											CLKSEL		RW			
Name																											CLKSEL					

Bit	Name	Reset	Access	Description
31:3	<i>Reserved</i>	<i>To ensure compatibility with future devices, always write Reserved bits to their reset value, unless otherwise stated. More information in 1.2 Conventions</i>		
2:0	CLKSEL	0x1	RW	Clock Select This bit controls which clock is used for EUSART0. EM01GRPCCLK should never be selected as clock source when disabling the EM01GRCCLK (e.g. because of EM23 entry).
	Value	Mode	Description	
	0	DISABLED	EUSART0 is not clocked	
	1	EM01GRPCCLK	EM01GRPCCLK is clocking EUSART0	
	2	HFRCOEM23	HFRCOEM23 is clocking EUSART0	
	3	LFRCO	LFRCO is clocking EUSART0	
	4	LFXO	LFXO is clocking EUSART0	

8.5.24 CMU_SYSRTC0CLKCTRL - System RTC0 Clock Control

Offset	Bit Position																															
0x240	31	30	29	28	27	26	25	24	23	22	21	20	19	18	17	16	15	14	13	12	11	10	9	8	7	6	5	4	3	2	1	0
Reset																															1	0x1
Access																															RW	
Name																															CLKSEL	

Bit	Name	Reset	Access	Description
31:2	<i>Reserved</i>	<i>To ensure compatibility with future devices, always write Reserved bits to their reset value, unless otherwise stated. More information in 1.2 Conventions</i>		
1:0	CLKSEL	0x1	RW	Clock Select Selects the clock source for SYSRTC0.
	Value	Mode	Description	
	1	LFRCO	LFRCO is clocking SYSRTC0CLK	
	2	LFXO	LFXO is clocking SYSRTC0CLK	
	3	ULFRCO	ULFRCO is clocking SYSRTC0CLK	

8.5.25 CMU_VDAC0CLKCTRL - VDAC0 Clock Control

Offset	Bit Position																															
0x260	31	30	29	28	27	26	25	24	23	22	21	20	19	18	17	16	15	14	13	12	11	10	9	8	7	6	5	4	3	2	1	0
Reset																											CLKSEL	0x1				
Access																											CLKSEL	RW				
Name																											CLKSEL					

Bit	Name	Reset	Access	Description
31:3	<i>Reserved</i>	<i>To ensure compatibility with future devices, always write Reserved bits to their reset value, unless otherwise stated. More information in 1.2 Conventions</i>		
2:0	CLKSEL	0x1	RW	Clock Select This bit controls which clock is used for VDAC. EM01GRPACLK should never be selected as clock source when disabling the EM01GRACLK (e.g. because of EM23 entry).
	Value	Mode	Description	
	0	DISABLED	VDAC is not clocked	
	1	EM01GRPACLK	EM01GRPACLK is clocking VDAC	
	2	EM23GRPACLK	EM23GRPACLK is clocking VDAC	
	3	FSRCO	FSRCO is clocking VDAC	
	4	HFRCOEM23	HFRCOEM23 is clocking VDAC	

8.5.26 CMU_PCNT0CLKCTRL - Pulse Counter 0 Clock Control

Offset	Bit Position																															
0x270	31	30	29	28	27	26	25	24	23	22	21	20	19	18	17	16	15	14	13	12	11	10	9	8	7	6	5	4	3	2	1	0
Reset																															1	0
Access																															RW	RW
Name																															CLKSEL	

Bit	Name	Reset	Access	Description
31:2	<i>Reserved</i>	<i>To ensure compatibility with future devices, always write Reserved bits to their reset value, unless otherwise stated. More information in 1.2 Conventions</i>		
1:0	CLKSEL	0x1	RW	Clock Select This bit controls which clock is used for PCNT0.
	Value	Mode	Description	
	0	DISABLED	PCNT0 is not clocked	
	1	EM23GRPACLK	EM23GRPACLK is clocking PCNT0	
	2	PCNTS0	External pin PCNT_S0 is clocking PCNT0	

8.5.27 CMU_RADIOCLKCTRL - Radio Clock Control

Offset	Bit Position																															
0x280	31	30	29	28	27	26	25	24	23	22	21	20	19	18	17	16	15	14	13	12	11	10	9	8	7	6	5	4	3	2	1	0
Reset	0x0																															0x0
Access	RW																															RW
Name	DBGCLK																															EN

Bit	Name	Reset	Access	Description
31	DBGCLK	0x0	RW	Enable Clock for Debugger When set to 1, this forces radio busmatrix and RAC clocks to run, allowing RAC sequencer debugger to stay attached.
30:1	<i>Reserved</i>	<i>To ensure compatibility with future devices, always write Reserved bits to their reset value, unless otherwise stated. More information in 1.2 Conventions</i>		
0	EN	0x0	RW	Enable Enables radio bridge clock

8.5.28 CMU_VDAC1CLKCTRL - VDAC1 Clock Control

Offset	Bit Position																															
0x294	31	30	29	28	27	26	25	24	23	22	21	20	19	18	17	16	15	14	13	12	11	10	9	8	7	6	5	4	3	2	1	0
Reset																											CLKSEL	0x1				
Access																											CLKSEL	RW				
Name																											CLKSEL					

Bit	Name	Reset	Access	Description
31:3	<i>Reserved</i>	<i>To ensure compatibility with future devices, always write Reserved bits to their reset value, unless otherwise stated. More information in 1.2 Conventions</i>		
2:0	CLKSEL	0x1	RW	Clock Select This bit controls which clock is used for VDAC. EM01GRPACLK should never be selected as clock source when disabling the EM01GRACLK (e.g. because of EM23 entry).
	Value	Mode	Description	
	0	DISABLED	VDAC is not clocked	
	1	EM01GRPACLK	EM01GRPACLK is clocking VDAC	
	2	EM23GRPACLK	EM23GRPACLK is clocking VDAC	
	3	FSRCO	FSRCO is clocking VDAC	
	4	HFRCOEM23	HFRCOEM23 is clocking VDAC	

9. Oscillators

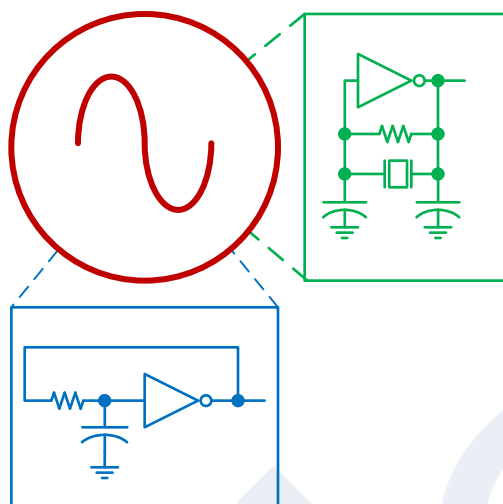
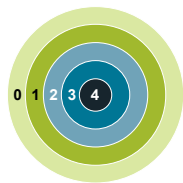

Quick Facts

What?

The EFR32xG24 has a wide range of high frequency and low frequency oscillators.

Why?

The High Frequency oscillators support EM0/1 operation. The Low-frequency oscillators provide a low frequency clock for the low energy peripherals in EM2/3/4.

How?

The HFXO supports high frequency crystal oscillators. The LFXO supports 32.768 kHz crystal oscillators. The RC oscillators are internal oscillators that require no external components.

9.1 Introduction

The EFR32xG24 has several oscillators. This chapter contains a detailed function description and register descriptions for each oscillator. The CMU chapter includes information on how to select clock sources. Each oscillator may require some initial configuration or calibration before being enabled. The CMU supports clock on demand and can enable and disable oscillators. Therefore, it is important to properly configure each oscillator before selecting it as a clock source in the CMU.

9.2 HFXO - High Frequency Crystal Oscillator

9.2.1 Introduction

The High Frequency Crystal Oscillator (HFXO) uses an external high frequency crystal and provides a sequencer for starting up the crystal safely and reliably, while minimize energy consumption. An external sine wave clock source can also be used in the absence of a crystal.

9.2.2 Features

- Optimized for 39.0 MHz crystals
- Multiple programming options of start-up parameters to enable optimization of different crystals, supporting a wide range of ESR and ESL
- Support for external sine wave input
- Programmable two-phase start-up to minimize energy consumption
- Built-in current optimization (Automatic oscillation amplitude control)
- Independent on-chip frequency tuning capacitors
- Hardware request for on-demand enable/disable
- Register lock

9.2.3 Functional Description

9.2.3.1 Enabling and Disabling

While the HFXO supports on-demand clocking, it is generally recommended to manually manage the HFXO, at least initially, because it requires software configuration and has a long start-up time. Software can set the FORCEEN to start HFXO and keep it enabled even if it is not selected as a clock source.

However, once started and before EM2 entry, switching the HFXO to on-demand mode may be desirable. This allows the MCU to enter EM2 and then restart the HFXO automatically upon EM2 exit. (During EM1P the HFXO can be conditionally started, depending on the wake-up trigger source.)

The HFXO can be enabled and disabled via both hardware and software mechanisms. Enabling via software is done by setting the FORCEEN bit in the HFXO_CTRL register. Disabling via software is done by setting the DISONDEMAND bit and clearing FORCEEN bit in the HFXO_CTRL register. The hardware controlled on-demand mode is enabled by clearing the FORCEEN and DISONDEMAND bits in the HFXO_CTRL register. Once configured the on-demand mode hardware can autonomously start and stop the HFXO based on various peripheral clock requests in combination with clock switch selections in the CMU. The HFXO is automatically stopped when entering EM2, EM3, or EM4. Hardware can also stop the HFXO via hardware in response to change in peripheral requests and clock switch selections in the CMU.

9.2.3.2 Start-up Time

The start-up time differs for different crystals and the HFXO has a configurable time-out to accommodate each crystal type. Software configures the timeout by setting the various TIMEOUT bit fields of the HFXO_XTALCFG register. The time-out delays the assertion of the RDY signal for HFXO. The programmed timeout should allow enough time for the oscillator to stabilize. The time-out can be optimized for the chosen crystal used in the application.

The start-up behavior of the HFXO also depends on how and how long the HFXO is disabled.

9.2.3.3 Configuration

The High Frequency Crystal Oscillator needs to be configured to ensure safe start-up for the given crystal. Refer to the Device Data sheet and application notes for guidelines in selecting correct components and crystals as well as for configuration trade-offs.

The HFXO crystal is connected to the HFXTAL_I/HFXTAL_O pins as shown in [Figure 9.1 HFXO Pin Connection on page 194](#).

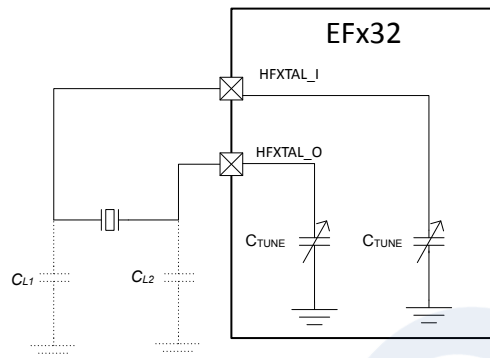

Figure 9.1. HFXO Pin Connection

Upon enabling the HFXO, a hardware state machine sequentially applies the configurable start-up state, intermediate start-up state, and steady state control settings from the HFXO_XTALCFG and HFXO_XTALCTRL registers. After reaching the steady operation state of the HFXO, it is recommended to further optimize current consumption using the Core Bias Optimization Algorithm to trade off noise and current consumption.

Refer to [AN0016.2](#) for more information on settings for different crystals. Write the configuration values, which depends on the crystal's CL, RESR and oscillation frequency, into HFXO_XTALCFG and HFXO_XTALCTRL registers.

- COREBIASSTARTUP (HFXO_XTALCFG) - current setting applied at start-up time
- COREBIASSTARTUPI (HFXO_XTALCFG) - current setting applied at intermediate start-up time
- COREBIASANA (HFXO_XTALCTRL) - current setting applied at steady state
- CTUNEXISTARTUP (HFXO_XTALCFG) - tuning cap setting for XI applied at start-up time
- CTUNEXIANA (HFXO_XTALCTRL) - tuning cap setting for XI applied at steady state
- CTUNEXOSTARTUP (HFXO_XTALCFG) - tuning cap setting for XO applied at start-up time
- CTUNEXOANA (HFXO_XTALCTRL) - tuning cap setting for XO applied at steady state
- CTUNEFIXANA (HFXO_XTALCTRL) - fixed tuning cap setting applied throughout
- TIMEOUTSTEADY (HFXO_XTALCFG) - duration for the steady state settling time
- TIMEOUTCBLBS (HFXO_XTALCFG) - duration for the optimization settling after each step

All HFXO configuration needs to be performed prior to enabling the HFXO, whether via software by setting FORCEEN bit field, or allowing hardware request by clearing DISONDEMAND bit field in the HFXO_CTRL register.

By default, the HFXO is started in crystal mode, but it is possible to connect an active external sine or clipped sine wave clock source to the HFXTAL_I pin of the HFXO. By configuring the MODE field in HFXO_CFG to EXTCLK, the HFXO can be bypassed and the source clock can be provided through the HFXTAL_I pin.

9.2.3.4 Status Flags

The ENS flag in the HFXO_STATUS indicates if the HFXO has been successfully enabled. Once the HFXO oscillation amplitude has exceeded the start-up threshold and intermediate start-up threshold, the steady state settling timeout begins. When the steady state timeout has expired, the HFXO is ready for use as indicated by the RDY flag in the HFXO_STATUS. Once Core Bias Optimization is enabled, the COREBIASOPTRDY flag in the CMU_STATUS register indicates when the optimization is ready. It is advised to wait for this flag before using the HFXO, because optimization can cause minor disturbance to the oscillator frequency.

9.2.3.5 On-Demand Clocking

Hardware can request to enable the HFXO by setting the HFXO_STATUS.HWREQ bit field. The HFXO can also optionally be configured via the HFXO_STATUS.DISONDEMAND to shut down when no hardware request is present. This is known as on-demand clocking and allows the oscillator to be controlled without any software intervention. On-demand HFXO enable can be used, for example, upon wake-up of the Radio Controller (RAC). The RAC module always requires the HFXO for its operation. Any hardware request for HFXO, including request from RAC, is indicated in the HWREQ bit field of the HFXO_STATUS register. This request enables the HFXO, provided that DISONDEMAND bit field is cleared in HFXO_CTRL register. The HFXO is only disabled by hardware upon EM2, EM3 or EM4 entry.

The HFXO analog circuitry can optionally continue operating with the clock output shut off when the HFXO is disabled. This is configured by setting the KEEPWARM bit in HFXO_STATUS.

9.2.3.6 Interrupts

RDYIF and COREBIASOPTRDYIF are interrupt flags as well as status flags. This allows software flexibility to implement interrupt service routine or polling loop for these events. When steady state timeout has exceeded, sticky RDYIF is set until it is cleared by software. If optimization is enabled, sticky COREBIASOPTRDYIF is set when optimization is completed successfully. However, if optimization fails to complete, sticky COREBIASOPTERRIF is set, and the HFXO control state machine stays in the error state until the oscillator is disabled. Similarly, if HFXO fails to start-up, meaning it has not reached the steady state, sticky DNSERRIF is set. The HFXO control state machine stays in the error state until the oscillator is disabled.

9.2.3.7 Protection

It is possible to lock the control registers, configuration registers, and command register to prevent unintended software writes to critical clock settings. This is controlled by the HFXO_LOCK register. A LOCK bit is available in HFXO_STATUS register. Furthermore, these registers are locked automatically by hardware to prevent clock domain crossing malfunction. To gain access to these registers while oscillator is in steady operation state, set FORCEEN to 1, then set DISONDEMAND to 1 in the HFXO_CTRL register. A FSMLOCK bit in HFXO_STATUS register indicates when it is safe for software to update control registers and configuration registers. When software is finished with updates, put the oscillator back to on-demand mode by clearing DISONDEMAND to 0, followed by clearing FORCEEN to 0 in the HFXO_CTRL register. While DISONDEMAND is 0, FSMLOCK is always set, even if hardware is not requesting. This is to prevent a race condition between software access and hardware lock.

9.2.3.8 Tuning

While the oscillator is running in steady operation state, it may be desirable to change control settings. One example is frequency tuning by modifying the tuning capacitance via CTUNEXIANA and CTUNEXOANA fields in the HFXO_XTALCTRL register. When tuning, care should be taken to make small changes to the CTUNE registers. Ideally, change the CTUNE registers by one LSB at a time and alternate between the XI and XO registers. Sufficient wait time for settling, on the order of TIMEOUTSTEADY, should pass before new frequency measurement is taken.

Note: While the HFXO can support crystals with a tuning range of 38 MHz to 40 MHz, the radio specifically requires a 39.0 MHz crystal. There may also be specific crystal tolerance requirements for each RF protocol supported by the radio.

9.2.3.9 High Frequency Clock Output (HFCLKOUT)

Certain device package options include a dedicated HFCLKOUT pin. This signal is designed to be a very high quality sinusoidal clock output operating at the crystal frequency. It is suitable for driving the crystal input on other Silicon Labs EFR products, and enables multi-radio systems operating from a single crystal. When using the HFCLKOUT feature, there are additional controls and considerations.

Enabling and Disabling

The HFCLKOUT feature can be enabled and disabled through software or hardware. To enable the output buffer in software the FORCEENBUFOUT bit in HFXO_CTRL should be set to 1. To disable, the DISONDEMANDBUFOUT bit should be set to 1 and FORCEENBUFOUT cleared to 0 in HFXO_CTRL.

Hardware (on-demand) control is possible as well. The on-demand hardware mechanism uses a GPIO input (HFXO0.BUF-OUT_REQ_IN_ASYNC, routed to PA or PB pin in the GPIO interface) to allow the other radio device to request the oscillator output. The external device requests HFCLKOUT by setting the input high. If the HFXO is not already running when external hardware requests HFCLKOUT, the HFXO will automatically be enabled and stabilized before the HFCLKOUT buffer turns on. When the external hardware enable request becomes inactive (input logic low), the HFXO block may also be automatically shut down to save energy if no other HFXO requestors are active.

Hardware control is enabled by clearing both the FORCEENBUFOUT and DISONDEMANDBUFOUT bits in the HFXO_CTRL register.

Note: Under hardware control, HFCLKOUT is available in EM0, EM1, EM2 and EM3 and will be automatically shut down in EM4.

Tuning

If the HFCLKOUT feature is enabled, CTUNEXIBUFOUTANA should normally be set to CTUNEXIANA. This will guarantee a maximum capacitance change of ± 300 fF between enabling/disabling HFCLKOUT (expected maximum frequency shift of ± 10 ppm for a typical crystal). For a lower frequency shift, it is recommended to tune CTUNEXIBUFOUTANA at the target frequency while HFCLKOUT is enabled.

9.2.4 HFXO Register Map

The offset register address is relative to the registers base address.

Offset	Name	Type	Description
0x000	HFXO_IPVERSION	R	IP Version ID
0x010	HFXO_XTALCFG	RW SYNC	Crystal Configuration Register
0x018	HFXO_XTALCTRL	RWH SYNC	Crystal Control Register
0x01C	HFXO_XTALCTRL1	RW SYNC	BUFOUT Crystal Control Register
0x020	HFXO_CFG	RW SYNC	Configuration Register
0x028	HFXO_CTRL	RWH SYNC	Control Register
0x040	HFXO_BUFOUTTRIM	RW SYNC	BUFOUT Trim Configuration Register
0x044	HFXO_BUFOUTCTRL	RW SYNC	BUFOUT Control Register
0x050	HFXO_CMD	W SYNC	Command Register
0x058	HFXO_STATUS	RH	Status Register
0x070	HFXO_IF	RWH INTFLAG	Interrupt Flag Register
0x074	HFXO_IEN	RW	Interrupt Enable Register
0x080	HFXO_LOCK	W	Configuration Lock Register
0x1000	HFXO_IPVERSION_SET	R	IP Version ID
0x1010	HFXO_XTALCFG_SET	RW SYNC	Crystal Configuration Register
0x1018	HFXO_XTALCTRL_SET	RWH SYNC	Crystal Control Register
0x101C	HFXO_XTALCTRL1_SET	RW SYNC	BUFOUT Crystal Control Register
0x1020	HFXO_CFG_SET	RW SYNC	Configuration Register
0x1028	HFXO_CTRL_SET	RWH SYNC	Control Register
0x1040	HFXO_BUFOUTTRIM_SET	RW SYNC	BUFOUT Trim Configuration Register
0x1044	HFXO_BUFOUTCTRL_SET	RW SYNC	BUFOUT Control Register
0x1050	HFXO_CMD_SET	W SYNC	Command Register
0x1058	HFXO_STATUS_SET	RH	Status Register
0x1070	HFXO_IF_SET	RWH INTFLAG	Interrupt Flag Register
0x1074	HFXO_IEN_SET	RW	Interrupt Enable Register
0x1080	HFXO_LOCK_SET	W	Configuration Lock Register
0x2000	HFXO_IPVERSION_CLR	R	IP Version ID
0x2010	HFXO_XTALCFG_CLR	RW SYNC	Crystal Configuration Register
0x2018	HFXO_XTALCTRL_CLR	RWH SYNC	Crystal Control Register
0x201C	HFXO_XTALCTRL1_CLR	RW SYNC	BUFOUT Crystal Control Register
0x2020	HFXO_CFG_CLR	RW SYNC	Configuration Register
0x2028	HFXO_CTRL_CLR	RWH SYNC	Control Register
0x2040	HFXO_BUFOUTTRIM_CLR	RW SYNC	BUFOUT Trim Configuration Register
0x2044	HFXO_BUFOUTCTRL_CLR	RW SYNC	BUFOUT Control Register
0x2050	HFXO_CMD_CLR	W SYNC	Command Register

Offset	Name	Type	Description
0x2058	HFXO_STATUS_CLR	RH	Status Register
0x2070	HFXO_IF_CLR	RWH INTFLAG	Interrupt Flag Register
0x2074	HFXO_IEN_CLR	RW	Interrupt Enable Register
0x2080	HFXO_LOCK_CLR	W	Configuration Lock Register
0x3000	HFXO_IPVERSION_TGL	R	IP Version ID
0x3010	HFXO_XTALCFG_TGL	RW SYNC	Crystal Configuration Register
0x3018	HFXO_XTALCTRL_TGL	RWH SYNC	Crystal Control Register
0x301C	HFXO_XTALCTRL1_TGL	RW SYNC	BUFOUT Crystal Control Register
0x3020	HFXO_CFG_TGL	RW SYNC	Configuration Register
0x3028	HFXO_CTRL_TGL	RWH SYNC	Control Register
0x3040	HFXO_BUFOUTTRIM_TGL	RW SYNC	BUFOUT Trim Configuration Register
0x3044	HFXO_BUFOUTCTRL_TGL	RW SYNC	BUFOUT Control Register
0x3050	HFXO_CMD_TGL	W SYNC	Command Register
0x3058	HFXO_STATUS_TGL	RH	Status Register
0x3070	HFXO_IF_TGL	RWH INTFLAG	Interrupt Flag Register
0x3074	HFXO_IEN_TGL	RW	Interrupt Enable Register
0x3080	HFXO_LOCK_TGL	W	Configuration Lock Register

9.2.5 HFXO Register Description

9.2.5.1 HFXO_IPVERSION - IP Version ID

Offset	Bit Position																															
0x000	31	30	29	28	27	26	25	24	23	22	21	20	19	18	17	16	15	14	13	12	11	10	9	8	7	6	5	4	3	2	1	0
Reset																	0x3															
Access																	R															
Name																	IPVERSION															

Bit	Name	Reset	Access	Description
31:0	IPVERSION	0x3	R	IP Version ID

The read only IPVERSION field gives the version for this module. There may be minor software changes required for modules with different values of IPVERSION.

9.2.5.2 HFXO_XTALCFG - Crystal Configuration Register

Offset	Bit Position																															
0x010	31	30	29	28	27	26	25	24	23	22	21	20	19	18	17	16	15	14	13	12	11	10	9	8	7	6	5	4	3	2	1	0
Reset					0xB				0xB				0x0				0x0				0x20				0x20							
Access					RW				RW				RW				RW				RW				RW							
Name					TIMEOUTCBLBSB				TIMEOUTSTEADY				CTUNEXOSTARTUP				CTUNEXISTARTUP				COREBIASSTARTUP				COREBIASSTARTUPI							

Bit	Name	Reset	Access	Description
31:28	Reserved	To ensure compatibility with future devices, always write Reserved bits to their reset value, unless otherwise stated. More information in 1.2 Conventions		
27:24	TIMEOUTCBLBSB	0xB	RW	Core Bias LSB Change Timeout wait duration for the COREBIAS change to settle out, used at each step of COREBIAS optimization algorithm
	Value	Mode		Description
	0	T8US		The core bias LSB change timeout is set to 8 us minimum. The maximum can be +40%.
	1	T20US		The core bias LSB change timeout is set to 20 us minimum. The maximum can be +40%.
	2	T41US		The core bias LSB change timeout is set to 41 us minimum. The maximum can be +40%.
	3	T62US		The core bias LSB change timeout is set to 62 us minimum. The maximum can be +40%.
	4	T83US		The core bias LSB change timeout is set to 83 us minimum. The maximum can be +40%.
	5	T104US		The core bias LSB change timeout is set to 104 us minimum. The maximum can be +40%.
	6	T125US		The core bias LSB change timeout is set to 125 us minimum. The maximum can be +40%.
	7	T166US		The core bias LSB change timeout is set to 166 us minimum. The maximum can be +40%.
	8	T208US		The core bias LSB change timeout is set to 208 us minimum. The maximum can be +40%.
	9	T250US		The core bias LSB change timeout is set to 250 us minimum. The maximum can be +40%.
	10	T333US		The core bias LSB change timeout is set to 333 us minimum. The maximum can be +40%.
	11	T416US		The core bias LSB change timeout is set to 416 us minimum. The maximum can be +40%.
	12	T833US		The core bias LSB change timeout is set to 833 us minimum. The maximum can be +40%.

Bit	Name	Reset	Access	Description
	13	T1250US		The core bias LSB change timeout is set to 1250 us minimum. The maximum can be +40%.
	14	T2083US		The core bias LSB change timeout is set to 2083 us minimum. The maximum can be +40%.
	15	T3750US		The core bias LSB change timeout is set to 3750 us minimum. The maximum can be +40%.
23:20	TIMEOUTSTEADY	0xB	RW	Steady State Timeout wait duration for the steady state settings to settle out
	Value	Mode		Description
	0	T4US		The steady state timeout is set to 16 us minimum. The maximum can be +40%.
	1	T16US		The steady state timeout is set to 41 us minimum. The maximum can be +40%.
	2	T41US		The steady state timeout is set to 83 us minimum. The maximum can be +40%.
	3	T83US		The steady state timeout is set to 125 us minimum. The maximum can be +40%.
	4	T125US		The steady state timeout is set to 166 us minimum. The maximum can be +40%.
	5	T166US		The steady state timeout is set to 208 us minimum. The maximum can be +40%.
	6	T208US		The steady state timeout is set to 250 us minimum. The maximum can be +40%.
	7	T250US		The steady state timeout is set to 333 us minimum. The maximum can be +40%.
	8	T333US		The steady state timeout is set to 416 us minimum. The maximum can be +40%.
	9	T416US		The steady state timeout is set to 500 us minimum. The maximum can be +40%.
	10	T500US		The steady state timeout is set to 666 us minimum. The maximum can be +40%.
	11	T666US		The steady state timeout is set to 833 us minimum. The maximum can be +40%.
	12	T833US		The steady state timeout is set to 1666 us minimum. The maximum can be +40%.
	13	T1666US		The steady state timeout is set to 2500 us minimum. The maximum can be +40%.
	14	T2500US		The steady state timeout is set to 4166 us minimum. The maximum can be +40%.
	15	T4166US		The steady state timeout is set to 7500 us minimum. The maximum can be +40%.
19:16	CTUNEXOSTARTUP	0x0	RW	Startup Tuning Capacitance on XO 4 most significant bits of CTUNEXOANA applied during startup phase
15:12	CTUNEXISTARTUP	0x0	RW	Startup Tuning Capacitance on XI

Bit	Name	Reset	Access	Description
				4 most significant bits of CTUNEXIANA applied during startup phase
11:6	COREBIASSTARTUP	0x20	RW	Startup Core Bias Current 6 most significant bits of COREBIASANA applied during startup phase
5:0	COREBIASSTARTUPI	0x20	RW	Intermediate Startup Core Bias Current 6 most significant bits of COREBIASANA applied during intermediate startup phase

9.2.5.3 HFXO_XTALCTRL - Crystal Control Register

Offset	Bit Position																															
0x018	31	30	29	28	27	26	25	24	23	22	21	20	19	18	17	16	15	14	13	12	11	10	9	8	7	6	5	4	3	2	1	0
Reset	0x0				0x0		0x3					0x3C								0x3C											0x3C	
Access	RW				RW		RW					RW								RW											RW	
Name	SKIPCOREBIASOPT				COREDGENANA		CTUNEFIXANA					CTUNEXOANA								CTUNEXIANA										COREBIASANA		

Bit	Name	Reset	Access	Description															
31	SKIPCOREBIASOPT	0x0	RW	Skip Core Bias Optimization Set to skip the core bias current optimization algorithm at next startup. Reuse the value stored in COREBIASANA. At the successful completion of core bias current optimization algorithm, hardware sets this bit to skip optimization during subsequent startup.															
30:28	<i>Reserved</i>			<i>To ensure compatibility with future devices, always write Reserved bits to their reset value, unless otherwise stated. More information in 1.2 Conventions</i>															
27:26	COREDGENANA	0x0	RW	Core Degeneration Core degeneration control <table border="1"> <thead> <tr> <th>Value</th> <th>Mode</th> <th>Description</th> </tr> </thead> <tbody> <tr> <td>0</td> <td>NONE</td> <td>Do not apply core degeneration resistance</td> </tr> <tr> <td>1</td> <td>DGEN33</td> <td>Apply 33 ohm core degeneration resistance</td> </tr> <tr> <td>2</td> <td>DGEN50</td> <td>Apply 50 ohm core degeneration resistance</td> </tr> <tr> <td>3</td> <td>DGEN100</td> <td>Apply 100 ohm core degeneration resistance</td> </tr> </tbody> </table>	Value	Mode	Description	0	NONE	Do not apply core degeneration resistance	1	DGEN33	Apply 33 ohm core degeneration resistance	2	DGEN50	Apply 50 ohm core degeneration resistance	3	DGEN100	Apply 100 ohm core degeneration resistance
Value	Mode	Description																	
0	NONE	Do not apply core degeneration resistance																	
1	DGEN33	Apply 33 ohm core degeneration resistance																	
2	DGEN50	Apply 50 ohm core degeneration resistance																	
3	DGEN100	Apply 100 ohm core degeneration resistance																	
25:24	CTUNEFIXANA	0x3	RW	Fixed Tuning Capacitance Adds or removes fixed capacitance on XI or XO <table border="1"> <thead> <tr> <th>Value</th> <th>Mode</th> <th>Description</th> </tr> </thead> <tbody> <tr> <td>0</td> <td>NONE</td> <td>Remove fixed capacitance on XI and XO nodes</td> </tr> <tr> <td>1</td> <td>XI</td> <td>Adds fixed capacitance on XI node</td> </tr> <tr> <td>2</td> <td>XO</td> <td>Adds fixed capacitance on XO node</td> </tr> <tr> <td>3</td> <td>BOTH</td> <td>Adds fixed capacitance on both XI and XO nodes</td> </tr> </tbody> </table>	Value	Mode	Description	0	NONE	Remove fixed capacitance on XI and XO nodes	1	XI	Adds fixed capacitance on XI node	2	XO	Adds fixed capacitance on XO node	3	BOTH	Adds fixed capacitance on both XI and XO nodes
Value	Mode	Description																	
0	NONE	Remove fixed capacitance on XI and XO nodes																	
1	XI	Adds fixed capacitance on XI node																	
2	XO	Adds fixed capacitance on XO node																	
3	BOTH	Adds fixed capacitance on both XI and XO nodes																	
23:16	CTUNEXOANA	0x3C	RW	Tuning Capacitance on XO Approximately 80fF per step. 0 is min. 255 is max.															
15:8	CTUNEXIANA	0x3C	RW	Tuning Capacitance on XI Approximately 80fF per step. 0 is min. 255 is max.															
7:0	COREBIASANA	0x3C	RW	Core Bias Current															

Bit	Name	Reset	Access	Description
				Approximately 10uA per step

9.2.5.4 HFXO_XTALCTRL1 - BUFOUT Crystal Control Register

Offset	Bit Position																																			
0x01C	31	30	29	28	27	26	25	24	23	22	21	20	19	18	17	16	15	14	13	12	11	10	9	8	7	6	5	4	3	2	1	0				
Reset																									0x3C											
Access																									RW											
Name																									CTUNEXIBUFOUTANA											

Bit	Name	Reset	Access	Description
31:8	<i>Reserved</i>	<i>To ensure compatibility with future devices, always write Reserved bits to their reset value, unless otherwise stated. More information in 1.2 Conventions</i>		
7:0	CTUNEXIBUFOUTANA	0x3C	RW	BUFOUT Tuning Capacitance on XI Tuning Capacitance on XI when BUFOUT is ON. Approximately 80fF per step. 0 is min. 255 is max.

9.2.5.5 HFXO_CFG - Configuration Register

Offset	Bit Position																																
0x020	31	30	29	28	27	26	25	24	23	22	21	20	19	18	17	16	15	14	13	12	11	10	9	8	7	6	5	4	3	2	1	0	
Reset				0x1																											0x0	0x0	0x0
Access				RW																											RW	RW	RW
Name				FORCELFTIMEOUT																											SQBUFSCHTRGANA	ENXIDCBIASANA	MODE

Bit	Name	Reset	Access	Description
31:29	Reserved	To ensure compatibility with future devices, always write Reserved bits to their reset value, unless otherwise stated. More information in 1.2 Conventions		
28	FORCELFTIMEOUT	0x1	RW	Force Low Frequency Timeout For deterministic timeout, clear this bit and configure PRS to trigger based on 32kHz timer (e.g., RTC).
27:4	Reserved	To ensure compatibility with future devices, always write Reserved bits to their reset value, unless otherwise stated. More information in 1.2 Conventions		
3	SQBUFSCHTRGANA	0x0	RW	Squaring Buffer Schmitt Trigger Used in EXTCLK mode to prevent self oscillation
	Value	Mode	Description	
	0	DISABLE	Squaring buffer schmitt trigger is disabled	
	1	ENABLE	Squaring buffer schmitt trigger is enabled	
2	ENXIDCBIASANA	0x0	RW	Enable XI Internal DC Bias Set to enable internal DC bias. Bit is ignored in XTAL mode.
1:0	MODE	0x0	RW	Crystal Oscillator Mode Set this to configure the external source for the HFXO.
	Value	Mode	Description	
	0	XTAL	crystal oscillator	
	1	EXTCLK	external sinusoidal clock can be supplied on XI pin.	
	2	EXTCLKPKDET	external sinusoidal clock can be supplied on XI pin (peak detector used).	

9.2.5.6 HFXO_CTRL - Control Register

Offset	Bit Position																																	
0x028	31	30	29	28	27	26	25	24	23	22	21	20	19	18	17	16	15	14	13	12	11	10	9	8	7	6	5	4	3	2	1	0		
Reset						0x1	0x1	0x1						0x0	0x0	0x0			0x0				0x0				0x1	0x0	0x0	0x0	0x0	0x0		0x0
Access						RW	RW	RW						RW	RW	RW			RW				RW				RW	RW	RW	RW	RW	RW		RW
Name						DISONDEMANDBUFOUT	DISONDEMANDPRS	DISONDEMAND						FORCEENBUFOUT	FORCEENPRS	FORCEEN			PRSTATUSSEL1				PRSTATUSSELO				FORCECTUNEMAX	FORCEXO2GNDANA	FORCEXI2GNDANA	EM23ONDEMAND	KEEPWARM			BUFOUTFREEZE

Bit	Name	Reset	Access	Description
31:27	<i>Reserved</i>	<i>To ensure compatibility with future devices, always write Reserved bits to their reset value, unless otherwise stated. More information in 1.2 Conventions</i>		
26	DISONDEMANDBUFOUT	0x1	RW	Disable On-demand For BUFOUT Disable On Demand for the BUFOUT request interface.
25	DISONDEMANDPRS	0x1	RW	Disable On-demand For PRS Disable On Demand for the PRS request interface.
24	DISONDEMAND	0x1	RW	Disable On-demand For Digital Clock Disable On Demand for the digital clock request interface.
23:19	<i>Reserved</i>	<i>To ensure compatibility with future devices, always write Reserved bits to their reset value, unless otherwise stated. More information in 1.2 Conventions</i>		
18	FORCEENBUFOUT	0x0	RW	Force BUFOUT Request Force BUFOUT request.
17	FORCEENPRS	0x0	RW	Force PRS Oscillator Request Force PRS oscillator request.
16	FORCEEN	0x0	RW	Force Digital Clock Request Force digital clock request.
15:12	PRSTATUSSEL1	0x0	RW	PRS Status 1 Output Select Mux select for various status signals to be output through PRS.
	Value	Mode	Description	
	0	DISABLED	PRS mux outputs 0	
	1	ENS	PRS mux outputs enabled status	
	2	COREBIASOPTRDY	PRS mux outputs core bias optimization ready status	
	3	RDY	PRS mux outputs ready status	
	4	PRSRDY	PRS mux outputs PRS ready status	
	5	BUFOUTRDY	PRS mux outputs BUFOUT ready status	

Bit	Name	Reset	Access	Description
	8	HWREQ		PRS mux outputs oscillator requested by digital clock status
	9	PRSHWREQ		PRS mux outputs oscillator requested by PRS request status
	10	BUFOUHWREQ		PRS mux outputs oscillator requested by BUFOUT request status
11:8	PRSTATUSSEL0	0x0	RW	PRS Status 0 Output Select Mux select for various status signals to be output through PRS.
	Value	Mode		Description
	0	DISABLED		PRS mux outputs 0
	1	ENS		PRS mux outputs enabled status
	2	COREBIASOPTRDY		PRS mux outputs core bias optimization ready status
	3	RDY		PRS mux outputs ready status
	4	PRSRDY		PRS mux outputs PRS ready status
	5	BUFOUTRDY		PRS mux outputs BUFOUT ready status
	8	HWREQ		PRS mux outputs oscillator requested by digital clock status
	9	PRSHWREQ		PRS mux outputs oscillator requested by PRS request status
	10	BUFOUHWREQ		PRS mux outputs oscillator requested by BUFOUT request status
7	<i>Reserved</i>	<i>To ensure compatibility with future devices, always write Reserved bits to their reset value, unless otherwise stated. More information in 1.2 Conventions</i>		
6	FORCECTUNEMAX	0x1	RW	Force Tuning Cap to Max Value When oscillator is disabled, force tuning capacitor to maximum value. Set this bit to 1 in XTAL mode to prevent overshoot upon disable.
5	FORCEXO2GNDANA	0x0	RW	Force XO Pin to Ground Set to enable grounding of XO pin.
	Value	Mode		Description
	0	DISABLE		Disabled (not pulled)
	1	ENABLE		Enabled (pulled)
4	FORCEXI2GNDANA	0x0	RW	Force XI Pin to Ground Set to enable grounding of XI pin. Do not enable if MODE=EXTCLK and an external source is supplied.
	Value	Mode		Description
	0	DISABLE		Disabled (not pulled)
	1	ENABLE		Enabled (pulled)
3	EM23ONDEMAND	0x0	RW	On-demand During EM23 Use this bit to prevent EM23 shutdown of the module's power domain upon EM23 entry. Set this bit to 1 if on-demand requests are supposed to be honored while in EM23.
2	KEEPWARM	0x0	RW	Keep Warm

Bit	Name	Reset	Access	Description
				Upon disable, if this bit is set, analog oscillator will keep running, while clock output is shutoff. Clearing this bit has no effect until the next disable event.
1	<i>Reserved</i>	<i>To ensure compatibility with future devices, always write Reserved bits to their reset value, unless otherwise stated. More information in 1.2 Conventions</i>		
0	BUFOUTFREEZE	0x0	RW	Freeze BUFOUT Controls Freeze BUFOUT Controls in current state (ON or OFF).

9.2.5.7 HFXO_BUFOUTTRIM - BUFOUT Trim Configuration Register

Offset	Bit Position																															
0x040	31	30	29	28	27	26	25	24	23	22	21	20	19	18	17	16	15	14	13	12	11	10	9	8	7	6	5	4	3	2	1	0
Reset																													0x8			
Access																													RW			
Name																													VTRTRIMANA			

Bit	Name	Reset	Access	Description
31:4	<i>Reserved</i>	<i>To ensure compatibility with future devices, always write Reserved bits to their reset value, unless otherwise stated. More information in 1.2 Conventions</i>		
3:0	VTRTRIMANA	0x8	RW	BUFOUT Reference Trim Change this field to set bias levels between 200uA and 400uA. $\text{bias_current} = \text{VTRTCANA} * \text{VTRTRIMANA} * \text{scale_factor}$. The default setting corresponds to 200uA.

9.2.5.8 HFXO_BUFOUTCTRL - BUFOUT Control Register

Offset	Bit Position																															
0x044	31	30	29	28	27	26	25	24	23	22	21	20	19	18	17	16	15	14	13	12	11	10	9	8	7	6	5	4	3	2	1	0
Reset	0x0								0x6				0x4				0x3				0xC				0x1				0x5			
Access	RW								RW				RW				RW				RW				RW				RW			
Name	MINIMUMSTARTUPDELAY								TIMEOUTSTARTUP				TIMEOUTCTUNE				PEAKDETTRESANA				XOUTGMANA				XOUTCFANA				XOUTBIASANA			

Bit	Name	Reset	Access	Description
31	MINIMUMSTARTUPDELAY	0x0	RW	Minimum Startup Delay If set, BUFOUT does not start until timeout expires. This prevents waste of power if BUFOUT is ready too early.
30:24	<i>Reserved</i>	<i>To ensure compatibility with future devices, always write Reserved bits to their reset value, unless otherwise stated. More information in 1.2 Conventions</i>		
23:20	TIMEOUTSTARTUP	0x6	RW	Oscillator Startup Timeout Wait duration for the typical oscillator startup sequence to prevent BUFOUT starting too early, used when MINIMUMSTARTUPDELAY is set.
	Value	Mode	Description	
	0	T42US	The oscillator startup timeout is set to 42 us minimum. The maximum can be +40%.	
	1	T83US	The oscillator startup timeout is set to 83 us minimum. The maximum can be +40%.	
	2	T108US	The oscillator startup timeout is set to 108 us minimum. The maximum can be +40%.	
	3	T133US	The oscillator startup timeout is set to 133 us minimum. The maximum can be +40%.	
	4	T158US	The oscillator startup timeout is set to 158 us minimum. The maximum can be +40%.	
	5	T183US	The oscillator startup timeout is set to 183 us minimum. The maximum can be +40%.	
	6	T208US	The oscillator startup timeout is set to 208 us minimum. The maximum can be +40%.	
	7	T233US	The oscillator startup timeout is set to 233 us minimum. The maximum can be +40%.	
	8	T258US	The oscillator startup timeout is set to 258 us minimum. The maximum can be +40%.	
	9	T283US	The oscillator startup timeout is set to 283 us minimum. The maximum can be +40%.	

Bit	Name	Reset	Access	Description
	10	T333US		The oscillator startup timeout is set to 333 us minimum. The maximum can be +40%.
	11	T375US		The oscillator startup timeout is set to 375 us minimum. The maximum can be +40%.
	12	T417US		The oscillator startup timeout is set to 417 us minimum. The maximum can be +40%.
	13	T458US		The oscillator startup timeout is set to 458 us minimum. The maximum can be +40%.
	14	T500US		The oscillator startup timeout is set to 500 us minimum. The maximum can be +40%.
	15	T667US		The oscillator startup timeout is set to 667 us minimum. The maximum can be +40%.
19:16	TIMEOUTCTUNE	0x4	RW	Tuning Cap Change Timeout Wait duration for the CTUNE change to settle out, used when CTUNE changes as result of enabling BUFOUT.
	Value	Mode		Description
	0	T2US		The tuning cap change timeout is set to 2 us minimum. The maximum can be +40%.
	1	T5US		The tuning cap change timeout is set to 5 us minimum. The maximum can be +40%.
	2	T10US		The tuning cap change timeout is set to 10 us minimum. The maximum can be +40%.
	3	T16US		The tuning cap change timeout is set to 16 us minimum. The maximum can be +40%.
	4	T21US		The tuning cap change timeout is set to 21 us minimum. The maximum can be +40%.
	5	T26US		The tuning cap change timeout is set to 26 us minimum. The maximum can be +40%.
	6	T31US		The tuning cap change timeout is set to 31 us minimum. The maximum can be +40%.
	7	T42US		The tuning cap change timeout is set to 42 us minimum. The maximum can be +40%.
	8	T52US		The tuning cap change timeout is set to 52 us minimum. The maximum can be +40%.
	9	T63US		The tuning cap change timeout is set to 63 us minimum. The maximum can be +40%.
	10	T83US		The tuning cap change timeout is set to 83 us minimum. The maximum can be +40%.
	11	T104US		The tuning cap change timeout is set to 104 us minimum. The maximum can be +40%.
	12	T208US		The tuning cap change timeout is set to 208 us minimum. The maximum can be +40%.
	13	T313US		The tuning cap change timeout is set to 313 us minimum. The maximum can be +40%.
	14	T521US		The tuning cap change timeout is set to 521 us minimum. The maximum can be +40%.

Bit	Name	Reset	Access	Description
15		T938US		The tuning cap change timeout is set to 938 us minimum. The maximum can be +40%.
15:12	PEAKDETTRESANA	0x3	RW	Peak Detector Threshold for XOUT Sets the peak detector threshold for BUFOUT.
	Value	Mode		Description
	0	V105MV		
	1	V132MV		
	2	V157MV		
	3	V184MV		
	4	V210MV		
	5	V236MV		
	6	V262MV		
	7	V289MV		
	8	V315MV		
	9	V341MV		
	10	V367MV		
	11	V394MV		
	12	V420MV		
	13	V446MV		
	14	V472MV		
	15	V499MV		
11:8	XOUTGMANA	0xC	RW	
7:4	XOUTCFANA	0x1	RW	Buffer Gain Buffer gain.
3:0	XOUTBIASANA	0x5	RW	Driver Bias Current Driver bias current.

9.2.5.9 HFXO_CMD - Command Register

Offset	Bit Position																															
0x050	31	30	29	28	27	26	25	24	23	22	21	20	19	18	17	16	15	14	13	12	11	10	9	8	7	6	5	4	3	2	1	0
Reset																																0x0
Access																																W(nB)
Name																																COREBIASOPT

Bit	Name	Reset	Access	Description
31:1	<i>Reserved</i>	<i>To ensure compatibility with future devices, always write Reserved bits to their reset value, unless otherwise stated. More information in 1.2 Conventions</i>		
0	COREBIASOPT	0x0	W(nB)	<p>Core Bias Optimizaton</p> <p>On devices with a radio, this bit is used to start the core bias current optimization algorithm and run it one time. Optimization should be executed if the temperature changes by more than 40 degC. Do not run this command while the radio is in RX or TX modes. Do not issue this command more than once until COREBIASOPTRDY is asserted, or the previous command may be cancelled.</p>

9.2.5.10 HFXO_STATUS - Status Register

Offset	Bit Position																															
0x058	31	30	29	28	27	26	25	24	23	22	21	20	19	18	17	16	15	14	13	12	11	10	9	8	7	6	5	4	3	2	1	0
Reset	0x0	0x0									0x0	0x0	0x0		0x0	0x0	0x0												0x0	0x0	0x0	0x0
Access	R	R									R	R	R		R	R	R												R	R	R	R
Name	LOCK	SYNCBUSY									BUFOUHWREQ	PRSHWREQ	ISWARM		HWREQ	ENS	BUFOUTFROZEN												BUFOUTRDY	PRSRDY	COREBIASOPTRDY	RDY

Bit	Name	Reset	Access	Description									
31	LOCK	0x0	R	Configuration Lock Status Indicates the current status of configuration lock. <table border="1"> <thead> <tr> <th>Value</th> <th>Mode</th> <th>Description</th> </tr> </thead> <tbody> <tr> <td>0</td> <td>UNLOCKED</td> <td>Configuration lock is unlocked</td> </tr> <tr> <td>1</td> <td>LOCKED</td> <td>Configuration lock is locked</td> </tr> </tbody> </table>	Value	Mode	Description	0	UNLOCKED	Configuration lock is unlocked	1	LOCKED	Configuration lock is locked
Value	Mode	Description											
0	UNLOCKED	Configuration lock is unlocked											
1	LOCKED	Configuration lock is locked											
30	SYNCBUSY	0x0	R	Sync Busy Indicates synchronization is ongoing.									
29:22	<i>Reserved</i>	<i>To ensure compatibility with future devices, always write Reserved bits to their reset value, unless otherwise stated. More information in 1.2 Conventions</i>											
21	BUFOUHWREQ	0x0	R	Oscillator Requested by BUFOUT Request Oscillator is requested by the BUFOUT oscillator request interface.									
20	PRSHWREQ	0x0	R	Oscillator Requested by PRS Request Oscillator is requested by the PRS oscillator request interface.									
19	ISWARM	0x0	R	Oscillator Is Kept Warm Oscillator is currently kept in warm state. Re-enable from warm state skips startup sequence.									
18	<i>Reserved</i>	<i>To ensure compatibility with future devices, always write Reserved bits to their reset value, unless otherwise stated. More information in 1.2 Conventions</i>											
17	HWREQ	0x0	R	Oscillator Requested by Digital Clock Oscillator is requested by digital clock request interface.									
16	ENS	0x0	R	Enabled Status Oscillator is enabled.									
15	BUFOUTFROZEN	0x0	R	BUFOUT Frozen FSM is frozen with respect to starting BUFOUT enable or disable sequences.									
14:4	<i>Reserved</i>	<i>To ensure compatibility with future devices, always write Reserved bits to their reset value, unless otherwise stated. More information in 1.2 Conventions</i>											
3	BUFOUTRDY	0x0	R	BUFOUT Ready Status The BUFOUT clock is ready.									

Bit	Name	Reset	Access	Description
2	PRSRDY	0x0	R	PRS Ready Status The PRS oscillator startup is ready.
1	COREBIASOPTRDY	0x0	R	Core Bias Optimization Ready Core bias current optimization algorithm is complete.
0	RDY	0x0	R	Ready Status The digital clock branch (osc.clk_qual) is ready.

9.2.5.11 HFXO_IF - Interrupt Flag Register

Offset	Bit Position																															
0x070	31	30	29	28	27	26	25	24	23	22	21	20	19	18	17	16	15	14	13	12	11	10	9	8	7	6	5	4	3	2	1	0
Reset	0x0	0x0	0x0	0x0	0x0						0x0	0x0					0x0												0x0	0x0	0x0	0x0
Access	RW	RW	RW	RW	RW						RW	RW					RW												RW	RW	RW	RW
Name	COREBIASOPTERR	LFTIMEOUTERR	DNSERR	BUFOUTDNSERR	BUFOUTFREEZEERR						BUFOUTERR	PRSERR					BUFOUTFROZEN											BUFOUTRDY	PRSRDY	COREBIASOPTRDY	RDY	

Bit	Name	Reset	Access	Description
31	COREBIASOPTERR	0x0	RW	Core Bias Optimization Error Interrupt Core bias current optimization algorithm fails to complete.
30	LFTIMEOUTERR	0x0	RW	Low Frequency Timeout Error Interrupt Low frequency timeout triggers before the steady state timeout triggers.
29	DNSERR	0x0	RW	Did Not Start Error Interrupt Crystal oscillator fails to startup.
28	BUFOUTDNSERR	0x0	RW	BUFOUT Did Not Start Error Interrupt BUFOUT fails to startup.
27	BUFOUTFREEZEERR	0x0	RW	BUFOUT Freeze Error Interrupt BUFOUTFREEZE should not be set when HWREQ is low as this can prevent service to companion chip indefinitely.
26:22	Reserved	To ensure compatibility with future devices, always write Reserved bits to their reset value, unless otherwise stated. More information in 1.2 Conventions		
21	BUFOUTERR	0x0	RW	BUFOUT Request Error Interrupt BUFOUT request is asserted while oscillator is forced to shutdown.
20	PRSERR	0x0	RW	PRS Request Error Interrupt PRS request is asserted while oscillator is forced to shutdown.
19:16	Reserved	To ensure compatibility with future devices, always write Reserved bits to their reset value, unless otherwise stated. More information in 1.2 Conventions		
15	BUFOUTFROZEN	0x0	RW	BUFOUT FROZEN Interrupt FSM is frozen with respect to starting BUFOUT enable or disable sequences.
14:4	Reserved	To ensure compatibility with future devices, always write Reserved bits to their reset value, unless otherwise stated. More information in 1.2 Conventions		
3	BUFOUTRDY	0x0	RW	BUFOUT Ready Interrupt The BUFOUT clock is ready.
2	PRSRDY	0x0	RW	PRS Ready Interrupt The PRS oscillator startup is ready.
1	COREBIASOPTRDY	0x0	RW	Core Bias Optimization Ready Interrupt

Bit	Name	Reset	Access	Description
				Core bias current optimization algorithm is complete.
0	RDY	0x0	RW	Digital Clock Ready Interrupt The digital clock branch (osc.clk_qual) is ready.

9.2.5.12 HFXO_IEN - Interrupt Enable Register

Offset	Bit Position																															
0x074	31	30	29	28	27	26	25	24	23	22	21	20	19	18	17	16	15	14	13	12	11	10	9	8	7	6	5	4	3	2	1	0
Reset	0x0	0x0	0x0	0x0	0x0						0x0	0x0					0x0												0x0	0x0	0x0	0x0
Access	RW	RW	RW	RW	RW						RW	RW					RW												RW	RW	RW	RW
Name	COREBIASOPTERR	LFTIMEOUTERR	DNSERR	BUFOUTDNSERR	BUFOUTFREEZEERR						BUFOUTERR	PRSERR					BUFOUTFROZEN											BUFOUTRDY	PRSRDY	COREBIASOPTRDY	RDY	

Bit	Name	Reset	Access	Description
31	COREBIASOPTERR	0x0	RW	Core Bias Optimization Error Interrupt Core bias current optimization algorithm fails to complete.
30	LFTIMEOUTERR	0x0	RW	Low Frequency Timeout Error Interrupt Low frequency timeout triggers before the steady state timeout triggers.
29	DNSERR	0x0	RW	Did Not Start Error Interrupt Crystal oscillator fails to startup.
28	BUFOUTDNSERR	0x0	RW	BUFOUT Did Not Start Error Interrupt BUFOUT fails to startup.
27	BUFOUTFREEZEERR	0x0	RW	BUFOUT Freeze Error Interrupt BUFOUTFREEZE should not be set when HWREQ is low as this can prevent service to companion chip indefinitely.
26:22	<i>Reserved</i>	<i>To ensure compatibility with future devices, always write Reserved bits to their reset value, unless otherwise stated. More information in 1.2 Conventions</i>		
21	BUFOUTERR	0x0	RW	BUFOUT Request Error Interrupt BUFOUT request is asserted while oscillator is forced to shutdown.
20	PRSERR	0x0	RW	PRS Request Error Interrupt PRS request is asserted while oscillator is forced to shutdown.
19:16	<i>Reserved</i>	<i>To ensure compatibility with future devices, always write Reserved bits to their reset value, unless otherwise stated. More information in 1.2 Conventions</i>		
15	BUFOUTFROZEN	0x0	RW	BUFOUT FROZEN Interrupt FSM is frozen with respect to starting BUFOUT enable or disable sequences.
14:4	<i>Reserved</i>	<i>To ensure compatibility with future devices, always write Reserved bits to their reset value, unless otherwise stated. More information in 1.2 Conventions</i>		
3	BUFOUTRDY	0x0	RW	BUFOUT Ready Interrupt The BUFOUT clock is ready.
2	PRSRDY	0x0	RW	PRS Ready Interrupt The PRS oscillator startup is ready.
1	COREBIASOPTRDY	0x0	RW	Core Bias Optimization Ready Interrupt

Bit	Name	Reset	Access	Description
				Core bias current optimization algorithm is complete.
0	RDY	0x0	RW	Digital Clock Ready Interrupt The digital clock branch (osc.clk_qual) is ready.

9.2.5.13 HFXO_LOCK - Configuration Lock Register

Offset	Bit Position																															
0x080	31	30	29	28	27	26	25	24	23	22	21	20	19	18	17	16	15	14	13	12	11	10	9	8	7	6	5	4	3	2	1	0
Reset																																
Access																	W															
Name																	LOCKKEY															

Bit	Name	Reset	Access	Description
31:16	Reserved	<i>To ensure compatibility with future devices, always write Reserved bits to their reset value, unless otherwise stated. More information in 1.2 Conventions</i>		
15:0	LOCKKEY	0x580E	W	Configuration Lock Key Write any other value than the unlock code to lock registers from editing. Write the unlock code to unlock.
	Value	Mode	Description	
	22542	UNLOCK	Write this value to unlock	

9.3 HFRCO - High-Frequency RC Oscillator

9.3.1 Introduction

The HFRCO is a calibrated internal High Frequency RC oscillator.

9.3.2 Features

- 1 MHz - 80 MHz High Frequency RC Oscillator with DPLL working in EM01 (HFRCO0/HFRCODPLL)
- 1 MHz - 40 MHz High Frequency RC Oscillator working in EM23 (HFRCOEM23)
- Low start-up time
- Run-time band change or tuning

9.3.3 Functional Description

9.3.3.1 Start-up

The HFRCO starts up quickly in a few micro-seconds (refer to device data sheet for start-up time specifications.) After the start-up time, the RDY status bit will go high and the RDY interrupt will be triggered. It can take another two clock cycles for the clock to propagate through the CMU before the clock is seen by peripherals.

9.3.3.2 On-Demand Clocking

Software can request to enable the HFRCO by setting the HFRCO_CTRL.FORCEEN bit field. The HFRCO can also optionally be configured via the HFRCO_CTRL.DISONDEMAND to shut down when no hardware request is present. This is known as on-demand clocking and allows the oscillator to be controlled without any software intervention. This means that HFRCO receives a request for clock from the CMU whenever the oscillator clock is needed. These requests can come at any time from any power domain (depending on the which peripheral is requesting the clock.)

9.3.3.2.1 EM2/EM3 On-Demand Operation (HFRCOEM23)

The HFRCOEM23 can be used by certain peripherals as an on-demand, high-speed clock source in energy modes down to EM3. To enable operation as an on-demand clock in EM2 and EM3, the EM23ONDEMAND bit in the CTRL register should be set to 1. Setting this bit ensures that the associated PDO power domain will remain active and allow the oscillator to honor the request.

Note: This feature is not available on the HFRCODPLL oscillator, which only operates in EM0 and EM1.

9.3.3.3 Calibration

Several different frequencies are calibrated during production test on every device. In order to use a factory-calibrated value, software must read the value from the appropriate location in the DEVINFO page and write it to the CAL register.

The TUNING and FINETUNING bit fields in the CAL register can be used to trim HFRCO manually.

Software may write the CAL register at any time. If there is already a frequency updating occurring, the current change would apply when the previous update is done. FREQBSY in STATUS register indicates if the updating is finished.

The minimum and maximum frequencies attainable for each setting of the FREQRANGE field are listed in the device data sheet.

Table 9.1. HFRCODPLL Calibration Frequencies

DEVINFO Location	Target Frequency
HFRCODPLLCAL0	4 MHz
HFRCODPLLCAL1	5 MHz
HFRCODPLLCAL3	7 MHz
HFRCODPLLCAL4	10 MHz
HFRCODPLLCAL6	13 MHz
HFRCODPLLCAL7	16 MHz
HFRCODPLLCAL8	19 MHz (default)
HFRCODPLLCAL9	20 MHz
HFRCODPLLCAL10	26 MHz
HFRCODPLLCAL11	32 MHz
HFRCODPLLCAL12	38 MHz
HFRCODPLLCAL13	48 MHz
HFRCODPLLCAL14	56 MHz
HFRCODPLLCAL15	64 MHz
HFRCODPLLCAL16	80 MHz

9.3.3.4 Interrupts

HFRCO has one interrupt: IF.RDY. RDY is triggered when the timeout has finished and the qualified HFRCO clock is ready. The clock is gated until it is ready.

9.3.3.5 Status Flags

9.3.3.5.1 FREQBSY

The FREQBSY bit indicates the HFRCO is busy updating its frequency after writing to the CAL register. The FREQBSY bit should be used whenever frequency is changed. E.g. After software writes to the CAL register, FREQBSY would assert immediately. Software should wait for FREQBSY to be zero before attempting to write to the CAL register again.

For band-change, FREQBSY would not de-assert until after the timeout upon being re-enabled.

For normal start-up, FREQBSY would not assert.

When DPLL is on, FREQBSY would not assert as the frequency change is not caused by writing to the CAL register. When disabling DPLL the last tuning value is written back to the CAL register, which will assert FREQBSY.

9.3.3.5.2 ENS

ENS indicates the HFRCO is enabled. This flag is used to check if the HFRCO is enabled by any requester.

Note: When a band change occurs, the HFRCO is disabled and re-enabled. This will cause the ENS bit to briefly de-assert.

9.3.3.5.3 RDY

RDY indicates HFRCO is enabled and start-up timeout has exceeded. Used to check if the HFRCO clock is ready after enable.

Changing bands will de-assert RDY as the oscillator must reset and start up again.

9.3.3.5.4 SYNCBUSY

SYNCBUSY indicates ongoing synchronization of CAL register fields. Same as all other modules.

9.3.3.6 Forced Oscillator Control

The HFRCO can be forced on and off using the FORCEEN and DISONDEMAND bits in the CTRL register.

Setting FORCEEN will force the oscillator core to run, but peripherals will still need to request the clock to un-gate the clock signal.

9.3.3.7 Oscillator Modes

The HFRCO has three modes of operation, an **on-demand** mode (which is the normal software use case), a **force on** and a **force off** mode.

In **on-demand** mode the oscillator will start whenever a peripheral requests it. Which in most cases is whenever the peripheral is enabled.

In **force on** mode the analog core will run independently of whether it is requested or not. This can be useful for measuring analog current without any digital load on the clocks.

In **force off** mode, the analog core will be shut off independently of whether it is requested or not. This can be useful for changing analog test settings without risking glitches on the clock.

The DISONDEMAND bit can also be used to give software full control over the clock for exceptional cases where software control is desired.

Table 9.2. Oscillator modes

Bit Field	FORCEEN	DISONDEMAND
On-Demand (normal operation)	0	0
Forced On	1	X
Forced Off	0	1

9.3.4 HFRCO Register Map

The offset register address is relative to the registers base address.

Offset	Name	Type	Description
0x000	HFRCO_IPVERSION	R	IP Version ID
0x004	HFRCO_CTRL	RW	Ctrl Register
0x008	HFRCO_CAL	RWH SYNC	Calibration Register
0x00C	HFRCO_STATUS	RH	Status Register
0x010	HFRCO_IF	RWH INTFLAG	Interrupt Flag Register
0x014	HFRCO_IEN	RW	Interrupt Enable Register
0x01C	HFRCO_LOCK	W	Lock Register
0x1000	HFRCO_IPVERSION_SET	R	IP Version ID
0x1004	HFRCO_CTRL_SET	RW	Ctrl Register
0x1008	HFRCO_CAL_SET	RWH SYNC	Calibration Register
0x100C	HFRCO_STATUS_SET	RH	Status Register
0x1010	HFRCO_IF_SET	RWH INTFLAG	Interrupt Flag Register
0x1014	HFRCO_IEN_SET	RW	Interrupt Enable Register
0x101C	HFRCO_LOCK_SET	W	Lock Register
0x2000	HFRCO_IPVERSION_CLR	R	IP Version ID
0x2004	HFRCO_CTRL_CLR	RW	Ctrl Register
0x2008	HFRCO_CAL_CLR	RWH SYNC	Calibration Register
0x200C	HFRCO_STATUS_CLR	RH	Status Register
0x2010	HFRCO_IF_CLR	RWH INTFLAG	Interrupt Flag Register
0x2014	HFRCO_IEN_CLR	RW	Interrupt Enable Register
0x201C	HFRCO_LOCK_CLR	W	Lock Register
0x3000	HFRCO_IPVERSION_TGL	R	IP Version ID
0x3004	HFRCO_CTRL_TGL	RW	Ctrl Register
0x3008	HFRCO_CAL_TGL	RWH SYNC	Calibration Register
0x300C	HFRCO_STATUS_TGL	RH	Status Register
0x3010	HFRCO_IF_TGL	RWH INTFLAG	Interrupt Flag Register
0x3014	HFRCO_IEN_TGL	RW	Interrupt Enable Register
0x301C	HFRCO_LOCK_TGL	W	Lock Register

9.3.5 HFRCO Register Description

9.3.5.1 HFRCO_IPVERSION - IP Version ID

Offset	Bit Position																															
0x000	31	30	29	28	27	26	25	24	23	22	21	20	19	18	17	16	15	14	13	12	11	10	9	8	7	6	5	4	3	2	1	0
Reset	0x2																															
Access	R																															
Name	IPVERSION																															

Bit	Name	Reset	Access	Description
31:0	IPVERSION	0x2	R	IP Version
The read only IPVERSION field gives the version for this module. There may be minor software changes required for modules with different values of IPVERSION.				

9.3.5.2 HFRCO_CTRL - Ctrl Register

Offset	Bit Position																															
0x004	31	30	29	28	27	26	25	24	23	22	21	20	19	18	17	16	15	14	13	12	11	10	9	8	7	6	5	4	3	2	1	0
Reset	0x0																															
Access	RW																															
Name	EM23ONDEMAND, DISONDEMAND, FORCEEN																															

Bit	Name	Reset	Access	Description
31:3	<i>Reserved</i>	<i>To ensure compatibility with future devices, always write Reserved bits to their reset value, unless otherwise stated. More information in 1.2 Conventions</i>		
2	EM23ONDEMAND	0x0	RW	EM23 On-demand
Use this bit to prevent EM23 shutdown of the HFRCOEM23 low power domain (PD0C) upon EM23 entry. Set this bit to 1 if on-demand requests are supposed to be honored while in EM23.				
1	DISONDEMAND	0x0	RW	Disable On-demand
Setting this bit disable HFRCO on-demand feature				
0	FORCEEN	0x0	RW	Force Enable
Setting this bit force HFRCO enabled				

9.3.5.3 HFRCO_CAL - Calibration Register

Offset	Bit Position																															
0x008	31	30	29	28	27	26	25	24	23	22	21	20	19	18	17	16	15	14	13	12	11	10	9	8	7	6	5	4	3	2	1	0
Reset	0xA			0x2			0x0			0x3			0x8			0x1			0x1F						0x7F							
Access	RW			RW			RW			RW			RW			RW			RW			RW			RW							
Name	IREFTC			CMPSEL			CLKDIV			CMPBIAS			FREQRANGE			LDOHP			FINETUNING			TUNING										

Bit	Name	Reset	Access	Description
31:28	IREFTC	0xA	RW	Tempco Trim on Comparator Current Writing this field adjusts the temperature coefficient trim on comparator current.
27:26	CMPSEL	0x2	RW	Comparator Load Select Writing this field adjusts the active load for comparators.
25:24	CLKDIV	0x0	RW	Locally Divide HFRCO Clock Output Writing this field configures the HFRCO clock output divider.
	Value	Mode		Description
	0	DIV1		Divide by 1.
	1	DIV2		Divide by 2.
	2	DIV4		Divide by 4.
23:21	CMPBIAS	0x3	RW	Comparator Bias Current Writing this field adjusts the HFRCO comparator bias current.
20:16	FREQRANGE	0x8	RW	Frequency Range Writing this field adjusts the HFRCO frequency range.
15	LDOHP	0x1	RW	LDO High Power Mode Settings this bit puts the HFRCO LDO in high power mode.
14	<i>Reserved</i>	<i>To ensure compatibility with future devices, always write Reserved bits to their reset value, unless otherwise stated. More information in 1.2 Conventions</i>		
13:8	FINETUNING	0x1F	RW	Fine Tuning Value Writing this field adjusts the HFRCO fine tuning value. Higher value means lower frequency.
7	<i>Reserved</i>	<i>To ensure compatibility with future devices, always write Reserved bits to their reset value, unless otherwise stated. More information in 1.2 Conventions</i>		
6:0	TUNING	0x7F	RW	Tuning Value Writing this field adjusts the HFRCO tuning value. Higher value means lower frequency.

9.3.5.4 HFRCO_STATUS - Status Register

Offset	Bit Position																																
0x00C	31	30	29	28	27	26	25	24	23	22	21	20	19	18	17	16	15	14	13	12	11	10	9	8	7	6	5	4	3	2	1	0	
Reset	0x0															0x0															0x0	0x0	0x0
Access	R															R															R	R	R
Name	LOCK															ENS															SYNCBUSY	FREQBSY	RDY

Bit	Name	Reset	Access	Description
31	LOCK	0x0	R	Lock Status If set, all HFRCO lockable registers are locked.
	Value	Mode		Description
	0	UNLOCKED		HFRCO is unlocked
	1	LOCKED		HFRCO is locked
30:17	<i>Reserved</i>	<i>To ensure compatibility with future devices, always write Reserved bits to their reset value, unless otherwise stated. More information in 1.2 Conventions</i>		
16	ENS	0x0	R	Enable Status HFRCO is enabled.
15:3	<i>Reserved</i>	<i>To ensure compatibility with future devices, always write Reserved bits to their reset value, unless otherwise stated. More information in 1.2 Conventions</i>		
2	SYNCBUSY	0x0	R	Synchronization Busy This bit is set when there is an ongoing synchronization of CAL register bitfields.
1	FREQBSY	0x0	R	Frequency Updating Busy HFRCO is busy updating frequency.
0	RDY	0x0	R	Ready HFRCO is enabled and start-up time has exceeded.

9.3.5.5 HFRCO_IF - Interrupt Flag Register

Offset	Bit Position																															
0x010	31	30	29	28	27	26	25	24	23	22	21	20	19	18	17	16	15	14	13	12	11	10	9	8	7	6	5	4	3	2	1	0
Reset																																0x0
Access																																RW
Name																																RDY

Bit	Name	Reset	Access	Description
31:1	Reserved	To ensure compatibility with future devices, always write Reserved bits to their reset value, unless otherwise stated. More information in 1.2 Conventions		
0	RDY	0x0	RW	Ready Interrupt Flag Set when HFRCO is ready (start-up time exceeded).

9.3.5.6 HFRCO_IEN - Interrupt Enable Register

Offset	Bit Position																															
0x014	31	30	29	28	27	26	25	24	23	22	21	20	19	18	17	16	15	14	13	12	11	10	9	8	7	6	5	4	3	2	1	0
Reset																																0x0
Access																																RW
Name																																RDY

Bit	Name	Reset	Access	Description
31:1	Reserved	To ensure compatibility with future devices, always write Reserved bits to their reset value, unless otherwise stated. More information in 1.2 Conventions		
0	RDY	0x0	RW	RDY Interrupt Enable Enable/disable the RDY interrupt

9.3.5.7 HFRCO_LOCK - Lock Register

Offset	Bit Position																															
0x01C	31	30	29	28	27	26	25	24	23	22	21	20	19	18	17	16	15	14	13	12	11	10	9	8	7	6	5	4	3	2	1	0
Reset																	0x8195															
Access																	W															
Name																	LOCKKEY															

Bit	Name	Reset	Access	Description
31:16	Reserved	To ensure compatibility with future devices, always write Reserved bits to their reset value, unless otherwise stated. More information in 1.2 Conventions		
15:0	LOCKKEY	0x8195	W	Lock Key Write any other value than the unlock code to lock registers from editing. Write the unlock code to unlock.
	Value	Mode		Description
	33173	UNLOCK		Unlock code

9.4 DPLL - Digital Phased Locked Loop

9.4.1 Introduction

The Digital Phase-Locked Loop (DPLL) uses a reference clock to generate a desired clock frequency at a specified ratio to the reference clock.

9.4.2 Features

- Frequency Lock Mode
- Phase-Lock Mode
- Output frequency = $F_{REF} * (N+1) / (M+1)$, where N and M are 12-bit values
- Very fast lock time
- Very fast transient tracking
- Low output jitter
- Lock detection with an interrupt
- Lock fail detection with interrupts

9.4.3 Functional Description

9.4.3.1 Enabling and Disabling

The DPLL can be enabled and disabled by software via the DPLL_EN register. Before enabling DPLL, software should:

1. Select reference clock by setting the CLKSEL field in CMU_DPLLREFCLKCTRL.
2. The CMU should not be running from the HFRCO. If necessary, the CMU should switch to the FSRCO until after the DPLL has locked to avoid over-clocking due to overshoot. If necessary, select FSRCO or HFXO in the CMU_SYSCLOCKCTRL register CLKSEL field.
3. Configure the DPLL.
4. Make certain that the ENS bit in DPLL_STATUS is low.

The DPLL is disabled automatically when entering EM2, EM3, or EM4. Note that disabling the DPLL will not automatically turn off the reference clock. The CLKSEF field in CMU_DPLLREFCLKCTRL must be set to DISABLED before entering EM2 or the selected REFCLK may continue to run in EM2.

9.4.3.2 Lock Modes

The DPLL provides two lock modes, referred to as frequency-lock loop mode (FREQLL) and phase-lock loop mode (PHASELL). FREQLL mode keeps the DCO frequency-locked to the reference clock, which means the DCO frequency will be accurate. However, the phase error can accumulate over time and cause a non-zero average frequency error. FREQLL mode also provides better jitter and transient performance. PHASELL mode keeps the DCO phase-locked to the reference clock, which means the phase error does not accumulate over time, which makes the average frequency error zero. FREQLL mode is usually sufficient unless specific phase requirement exists.

9.4.3.3 Configurations

The formula for the DPLL output frequency is $FREF \cdot (N+1) / (M+1)$. The user should calculate N and M in DPLL_CFG1 to achieve the target frequency. Note that with a larger value of N, the DCO lock time would increase and DCO jitter would decrease. Both effects are approximately linear. This relationship can be used to select N for a given application to strike a compromise between lock time and output jitter. For example if an ratio of 3 is desired, the DPLL could be configured as {N=599, M=199} for fast lock time but high jitter, or as {N=2999, M=999} for lower jitter but longer lock time.

Note: All configuration settings should be done before enabling the DPLL. They should not be changed when DPLL is running. The final tuning values can be read back from TUNING and FINETUNING in HFRCO_CAL, after DPLL is disabled and DPLLENS in DPLL_STATUS is low.

9.4.3.4 Lock Detection

The DPLL has 3 different types of output events: ready, lock fail due to period underflow, and lock fail due to period overflow. Each of the events has its own interrupt flag. DPLLRDY is set when DPLL successfully locks to the reference clock based on the software configuration. DPLLLOCKFAILLOW is set when the DPLL fails to lock because the period lower boundary is hit. DPLLLOCKFAILHIGH is set when the DPLL fails to lock because the period upper boundary is hit. If the interrupt flags are set and the corresponding interrupt enable bits in DPLL_IEN are set, the DPLL will request an interrupt. Based on different interrupt events, software should take different actions:

- If the DPLLRDY interrupt is received first, it means target clock is ready and it is safe to switch to use DCO's output.
- If the DPLLLOCKFAILLOW interrupt is received first, it indicates the RANGE in HFRCO_CAL is too small. Software should disable the DPLL and write a larger value to RANGE, then enable the DPLL again to lock.
- If the DPLLLOCKFAILHIGH interrupt is received first, it indicates the RANGE in HFRCO_CAL is too large. Software should disable DPLL and write a smaller value to RANGE, then enable DPLL again to lock.
- If the DPLLRDY interrupt is received first and then DPLLLOCKFAILLOW or DPLLLOCKFAILHIGH is received later, it means reference clock drifted over 1% and the DPLL has lost its locked status.
 - If AUTORECOVER in DPLL_CFG is not set, software should disable the DPLL and enable DPLL again to lock.
 - If AUTORECOVER in DPLL_CFG is set, hardware will re-lock automatically. When the target frequency is near the boundary of a range, the drift may cause underflow or overflow. In this case the fail interrupt will still be received. Software should disable the DPLL and modify RANGE in HFRCO_CAL in corresponding direction, depending on whether the DPLLLOCKFAILLOW or DPLLLOCKFAILHIGH bit is set. Then enable DPLL again to lock.

9.4.4 DPLL Register Map

The offset register address is relative to the registers base address.

Offset	Name	Type	Description
0x000	DPLL_IPVERSION	R	IP Version
0x004	DPLL_EN	RW ENABLE	Enable
0x008	DPLL_CFG	RW CONFIG	Config
0x00C	DPLL_CFG1	RW CONFIG	Config1
0x010	DPLL_IF	RWH INTFLAG	Interrupt Flag
0x014	DPLL_IEN	RW	Interrupt Enable
0x018	DPLL_STATUS	RH	Status
0x024	DPLL_LOCK	W	Lock
0x1000	DPLL_IPVERSION_SET	R	IP Version
0x1004	DPLL_EN_SET	RW ENABLE	Enable
0x1008	DPLL_CFG_SET	RW CONFIG	Config
0x100C	DPLL_CFG1_SET	RW CONFIG	Config1
0x1010	DPLL_IF_SET	RWH INTFLAG	Interrupt Flag
0x1014	DPLL_IEN_SET	RW	Interrupt Enable
0x1018	DPLL_STATUS_SET	RH	Status
0x1024	DPLL_LOCK_SET	W	Lock
0x2000	DPLL_IPVERSION_CLR	R	IP Version
0x2004	DPLL_EN_CLR	RW ENABLE	Enable
0x2008	DPLL_CFG_CLR	RW CONFIG	Config
0x200C	DPLL_CFG1_CLR	RW CONFIG	Config1
0x2010	DPLL_IF_CLR	RWH INTFLAG	Interrupt Flag
0x2014	DPLL_IEN_CLR	RW	Interrupt Enable
0x2018	DPLL_STATUS_CLR	RH	Status
0x2024	DPLL_LOCK_CLR	W	Lock
0x3000	DPLL_IPVERSION_TGL	R	IP Version
0x3004	DPLL_EN_TGL	RW ENABLE	Enable
0x3008	DPLL_CFG_TGL	RW CONFIG	Config
0x300C	DPLL_CFG1_TGL	RW CONFIG	Config1
0x3010	DPLL_IF_TGL	RWH INTFLAG	Interrupt Flag
0x3014	DPLL_IEN_TGL	RW	Interrupt Enable
0x3018	DPLL_STATUS_TGL	RH	Status
0x3024	DPLL_LOCK_TGL	W	Lock

9.4.5 DPLL Register Description

9.4.5.1 DPLL_IPVERSION - IP Version

Offset	Bit Position																															
0x000	31	30	29	28	27	26	25	24	23	22	21	20	19	18	17	16	15	14	13	12	11	10	9	8	7	6	5	4	3	2	1	0
Reset	0x1																															
Access	R																															
Name	IPVERSION																															

Bit	Name	Reset	Access	Description
31:0	IPVERSION	0x1	R	IP Version ID
The read only IPVERSION field gives the version for this module. There may be minor software changes required for modules with different values of IPVERSION.				

9.4.5.2 DPLL_EN - Enable

Offset	Bit Position																															
0x004	31	30	29	28	27	26	25	24	23	22	21	20	19	18	17	16	15	14	13	12	11	10	9	8	7	6	5	4	3	2	1	0
Reset																															0x0	0x0
Access																															R	RW
Name																															DISABLING	EN

Bit	Name	Reset	Access	Description
31:2	<i>Reserved</i>	<i>To ensure compatibility with future devices, always write Reserved bits to their reset value, unless otherwise stated. More information in 1.2 Conventions</i>		
1	DISABLING	0x0	R	Disablement Busy Status
When EN is cleared, DISABLING status is set immediately, and cleared when disablement finishes. Disablement resets peripheral cores and not APB registers except hardware updated registers such as INTFLAGS and FIFO				
0	EN	0x0	RW	Module Enable
The ENABLE bit enables the module. Software should write to CONFIG type registers before setting the ENABLE bit. Software should write to SYNC type registers only after setting the ENABLE bit.				

9.4.5.3 DPLL_CFG - Config

Offset	Bit Position																																																														
0x008	31	30	29	28	27	26	25	24	23	22	21	20	19	18	17	16	15	14	13	12	11	10	9	8	7	6	5	4	3	2	1	0																															
Reset																									0x0																																0x0	0x0	0x0				
Access																									RW																																	RW	RW	RW			
Name																																																											DITHEN		AUTORECOVER	EDGESEL	MODE

Bit	Name	Reset	Access	Description
31:7	<i>Reserved</i>	<i>To ensure compatibility with future devices, always write Reserved bits to their reset value, unless otherwise stated. More information in 1.2 Conventions</i>		
6	DITHEN	0x0	RW	Dither Enable Control Set to enable dither function
5:3	<i>Reserved</i>	<i>To ensure compatibility with future devices, always write Reserved bits to their reset value, unless otherwise stated. More information in 1.2 Conventions</i>		
2	AUTORECOVER	0x0	RW	Automatic Recovery Control Set to enable automatic recovery function
1	EDGESEL	0x0	RW	Reference Edge Select This bit controls which edge of reference is detected
0	MODE	0x0	RW	Operating Mode Control This bit controls which mode DPLL is operating when enabled
	Value	Mode		Description
	0	FLL		Frequency Lock Mode
	1	PLL		Phase Lock Mode

9.4.5.4 DPLL_CFG1 - Config1

Offset	Bit Position																																									
0x00C	31	30	29	28	27	26	25	24	23	22	21	20	19	18	17	16	15	14	13	12	11	10	9	8	7	6	5	4	3	2	1	0										
Reset												0x0																					0x0									
Access												RW																					RW									
Name												N																					M									

Bit	Name	Reset	Access	Description
31:28	<i>Reserved</i>			<i>To ensure compatibility with future devices, always write Reserved bits to their reset value, unless otherwise stated. More information in 1.2 Conventions</i>
27:16	N	0x0	RW	Factor N The locked DCO frequency is given by: $F_{dco} = F_{ref} * (N + 1)/(M+1)$. N is required to be larger than 300.
15:12	<i>Reserved</i>			<i>To ensure compatibility with future devices, always write Reserved bits to their reset value, unless otherwise stated. More information in 1.2 Conventions</i>
11:0	M	0x0	RW	Factor M The locked DCO frequency is given by: $F_{dco} = F_{ref} * (N + 1)/(M+1)$. M can be any value.

9.4.5.5 DPLL_IF - Interrupt Flag

Offset	Bit Position																															
0x010	31	30	29	28	27	26	25	24	23	22	21	20	19	18	17	16	15	14	13	12	11	10	9	8	7	6	5	4	3	2	1	0
Reset																											0x0	0x0	0x0			
Access																											RW	RW	RW			
Name																											LOCKFAILHIGH	LOCKFAILLOW	LOCK			

Bit	Name	Reset	Access	Description
31:3	<i>Reserved</i>			<i>To ensure compatibility with future devices, always write Reserved bits to their reset value, unless otherwise stated. More information in 1.2 Conventions</i>
2	LOCKFAILHIGH	0x0	RW	Lock Failure High Interrupt Flag Set when DPLL fail to lock because of period overflow.
1	LOCKFAILLOW	0x0	RW	Lock Failure Low Interrupt Flag Set when DPLL fail to lock because of period underflow.
0	LOCK	0x0	RW	Lock Interrupt Flag Set when DPLL achieve the lock.

9.4.5.6 DPLL_IEN - Interrupt Enable

Offset	Bit Position																															
0x014	31	30	29	28	27	26	25	24	23	22	21	20	19	18	17	16	15	14	13	12	11	10	9	8	7	6	5	4	3	2	1	0
Reset																											0x0	0x0	0x0			
Access																											RW	RW	RW			
Name																											LOCKFAILHIGH	LOCKFAILLOW	LOCK			

Bit	Name	Reset	Access	Description
31:3	<i>Reserved</i>	<i>To ensure compatibility with future devices, always write Reserved bits to their reset value, unless otherwise stated. More information in 1.2 Conventions</i>		
2	LOCKFAILHIGH LOCKFAILHIGH Interrupt Enable	0x0	RW	LOCKFAILHIGH Interrupt Enable
1	LOCKFAILLOW LOCKFAILLOW Interrupt Enable	0x0	RW	LOCKFAILLOW Interrupt Enable
0	LOCK LOCK interrupt Enable	0x0	RW	LOCK interrupt Enable

9.4.5.7 DPLL_STATUS - Status

Offset	Bit Position																															
0x018	31	30	29	28	27	26	25	24	23	22	21	20	19	18	17	16	15	14	13	12	11	10	9	8	7	6	5	4	3	2	1	0
Reset	0x0																														0x0	0x0
Access	R																														R	R
Name	LOCK																														ENS	RDY

Bit	Name	Reset	Access	Description
31	LOCK	0x0	R	Lock Status Indicates the current status of configuration lock
	Value	Mode		Description
	0	UNLOCKED		DPLL is unlocked
	1	LOCKED		DPLL is locked
30:2	<i>Reserved</i>	<i>To ensure compatibility with future devices, always write Reserved bits to their reset value, unless otherwise stated. More information in 1.2 Conventions</i>		
1	ENS	0x0	R	Enable Status DPLL is enabled.
0	RDY	0x0	R	Ready Status DPLL is enabled and locked.

9.4.5.8 DPLL_LOCK - Lock

Offset	Bit Position																															
0x024	31	30	29	28	27	26	25	24	23	22	21	20	19	18	17	16	15	14	13	12	11	10	9	8	7	6	5	4	3	2	1	0
Reset																														0x7102		
Access																														W		
Name																														LOCKKEY		

Bit	Name	Reset	Access	Description
31:16	<i>Reserved</i>	<i>To ensure compatibility with future devices, always write Reserved bits to their reset value, unless otherwise stated. More information in 1.2 Conventions</i>		
15:0	LOCKKEY	0x7102	W	Lock Key Write any other value than the unlock code to lock registers from editing. Write the unlock code to unlock.
	Value	Mode		Description
	28930	UNLOCK		Unlock code

9.5 LFXO - Low-Frequency Crystal Oscillator

9.5.1 Introduction

The Low Frequency Crystal Oscillator (LFXO) uses an external 32.768 kHz crystal to provide an accurate low-frequency clock. The module is available in all energy modes, except EM3. The main interaction is with the CMU through the clock requesting mechanism.

9.5.2 Features

High-level features.

- Crystal calibration
- Functional in all energy modes, except EM3
- Failure detection and EM4WU
- External CMOS mode
- Edge interrupts and EM2WU
- On-demand oscillator enabling

9.5.3 Functional Description

9.5.3.1 Modes

The LFXO can be used in three different modes. The mode can be programmed by setting MODE bit field in the LFXO_CFG register. If MODE is set to XTAL, the LFXO is programmed to operate in crystal mode and a 32.768 kHz crystal oscillator should be connected to LF crystal pads, LFXTAL_I and LFXTAL_O (see the device data sheet for details). If MODE is set to BUFEXTCLK, the LFXO is programmed to operate in external sine mode and the sine wave should be supplied to LFXTAL_I pin. If MODE is set to DIGEXTCLK, LFXO is programmed to operate in external CMOS mode and the external 32.768 kHz clock should be provided on LFXTAL_I pin. See the register descriptions for more details.

9.5.3.2 Enabling

There are two ways to turn on the LFXO clock. One is to turn it on in FORCEON mode by setting FORCEEN bit to 1 in LFXO_CTRL register. Another is to keep it ready to be turned on in ONDEMAND mode by setting FORCEEN bit to 0 and DISONDEMAND bit to 0 in LFXO_CTRL register. This means that the oscillator will be off unless its clock requested. When a peripheral requests the clock, hardware will automatically enable the LFXO without any software intervention. The oscillator will remain on as long as the peripheral requests it. DISONDEMAND setting does not have any impact when FORCEEN set to 1. LFXO is in FORCEOFF mode when FORCEEN set to 0 and DISONDEMAND set to 1. In FORCEOFF mode all requests are blocked and LFXO will not generate the clock. The LFXO clock is available in all energy modes, except EM3.

9.5.3.3 Clock Qualification

Once the LFXO is enabled, the clock should not be used until it has had time to stabilize. Therefore, a number of cycles are required to qualify the clock. Before the clock is qualified, no clock requesters will receive the LFXO clock. The number of cycles used to qualify the clock can be programmed by setting the TIMEOUT bit field in the LFXO_CFG register. The TIMEOUT default value is set to 32,728 cycles, which is much more than necessary for stabilization. The stabilization time required will depend on the particular crystal, oscillator settings, and frequency accuracy requirements. A value of 4096 clocks is generally recommended for most applications. A low timeout of 2 cycles may be used in DIGEXTCLK mode in order to filter out the first glitch from the pad. The 2 clock cycle timeout should not be used with crystals. There are two status bits and one interrupt associated with enabling the oscillator and qualifying its clock. Once the oscillator gets enabled the ENS bit in LFXO_STATUS register will be set high. Note that due to the nature of on demand clocking, the oscillator can be enabled anytime, so if software reads ENS low it is not safe to assume that ENS stays low during the next instruction. It is only safe to assume that oscillator is OFF at the time ENS is being read. Similarly, if software reads ENS high it is not safe to assume that ENS stays high during the next instruction. Once the clock is qualified, the RDY status is set high in the LFXO_STATUS register. The same uncertainties also apply to the RDY bit. However, software can wait for RDY bit to go high to detect that LFXO clock is qualified. Or it can enable the interrupt with RDYIEN in LFXO_IEN register and receive RDYIF interrupt available in LFXO_IF register. RDYIF also acts as EM2 wakeup source if RDYIEN set high. If put into FORCEON mode, the LFXO will start the qualification and once qualified it will gate off the clock but immediately start with no qualification upon receiving a request. If in ONDEMAND mode, the LFXO starts the qualification every time it is switched from off to on due to clock requests. The qualification can take up to 32k cycles. Note that only enabling RDY interrupt does not act as a clock request.

9.5.3.4 Edge Detection Interrupts

There is a possibility for software to detect rising or falling edges of the LFXO clock. The edge detection is enabled if any of POSEDGEIEN and NEGEDGEIEN is set to 1. The corresponding flags are available in POSEDGEIF and NEGEDGEIF. If none of the interrupts are enabled, the edge detection is disabled and POSEDGEIF and NEGEDGEIF hold their last value until cleared or set by software. Disabling the edge detection is only allowed on NEGEDGEIF. Both flags act as EM2 wakeup sources if the corresponding IEN is set high.

9.5.3.5 Clock Failure

In case the oscillator or crystal stops or does not output clock when expected, a failure interrupt can be raised. The failure occurs if fewer than 3 LFXO clock positive edges happen during one 1ms. The failure detection is enabled by setting FAILDETEN to 1 in LFXO_CTRL register. This bit acts as a clock requester. Once enabled, failure detection status can be checked by reading FAILIF in LFXO_IF register. If FAILIEN is set high, failure will generate both interrupt and EM2 wakeup. Failure detection is also implemented as EM4 wakeup source. To wakeup from EM4 on LFXO failure detection, set FAILDETEM4WUEN high in LFXO_CTRL.

9.5.3.6 Automatic Gain Control

AGC and HIGHAMPL in LFXO_CFG are settings applied to the LFXO oscillator. Both settings provide higher crystal oscillation amplitude. This will improve duty cycle in the output clock and give lower sensitivity to noise, but at the cost of higher current consumption. The AGC bit is used to enable the Automatic Gain Control module that adjusts the amplitude of the oscillations. It is enabled by default. When disabled, the LFXO will run at the start-up current and the crystal will oscillate rail-to-rail or limited by the start-up current. The HIGHAMPL bit will have no effect when AGC is disabled. When AGC is enabled setting the HIGHAMPL bit will give about 70% higher crystal oscillation amplitude.

9.5.3.7 Force Off

It is not allowed to write to LFXO_CFG unless LFXO is in FORCEOFF mode. If this guideline is violated, the write access is blocked and a bus fault is generated. Writing to CFG registers has no effect in DIGEXTCLK mode. Note: when putting the oscillators to FORCEOFF mode, wait for ENS status to go low for the oscillator to completely shut off. Once the oscillator is forced off, it is safe to write to the LFXO_CFG register.

9.5.3.8 Register Synchronization

While the CFG registers are static LFXO configuration, LFXO_CAL register has GAIN and CAPTURE bit fields which can be written to while the oscillator is running. This is used to calibrate the LFXO clock. These registers are allowed to be written only if CALBSY in LFXO_SYNCBUSY register is low. If this guideline is violated, the write access is blocked and a bus fault is generated. CALBSY is guaranteed to be low in FORCEOFF mode. When exiting FORCEOFF mode, CALBSY will go high and stay high until the initial internal synchronization is done. CALBSY is also guaranteed to be low in DIGEXTCLK mode since writing to CAL register has no effect in DIGEXTCLK mode. CAPTURE is allowed to be incremented or decremented by one LSB when not in FORCEOFF mode. Note that CAPTURE tunes the internal capacitors connected to LFXTAL_I and LFXTAL_O pads (see Register map for more details). By programming GAIN bit field it is possible to optimize start-up time and power consumption for a given crystal. Internal capacitances are not provided on all chips (see the device data sheet for more details).

9.5.3.9 Register Lock

See the LFXO_LOCK register on how to lock certain registers. Registers LFXO_CTRL, LFXO_CFG, and LFXO_CAL are lockable. The LOCK bit in LFXO_STATUS register is available to check whether the registers are locked. If locked, all updates to these registers are blocked and bus faults are issued.

9.5.3.10 Reset Behavior

Upon reset, the LFXO is configured for the safe crystal start-up. The TIMEOUT is set to 32k cycles, The MODE is set to XTAL and the reset state is FORCEOFF. In order to minimize the start-up time and power consumption for a given crystal, it is possible to adjust the start-up gain in the oscillator by programming GAIN in LFXO_CAL. All controls are retained in EM4, except LFXO_IEN register which is reset after EM4 wakeup.

9.5.4 LFXO Register Map

The offset register address is relative to the registers base address.

Offset	Name	Type	Description
0x000	LFXO_IPVERSION	R	LFXO IP Version
0x004	LFXO_CTRL	RW	LFXO Control Register
0x008	LFXO_CFG	RW	LFXO Configuration Register
0x010	LFXO_STATUS	RH	LFXO Status Register
0x014	LFXO_CAL	RW LFSYNC	LFXO Calibration Register
0x018	LFXO_IF	RWH INTFLAG	Interrupt Flag Register
0x01C	LFXO_IEN	RW	Interrupt Enable Register
0x020	LFXO_SYNCBUSY	RH	LFXO Sync Busy Register
0x024	LFXO_LOCK	W	Configuration Lock Register
0x1000	LFXO_IPVERSION_SET	R	LFXO IP Version
0x1004	LFXO_CTRL_SET	RW	LFXO Control Register
0x1008	LFXO_CFG_SET	RW	LFXO Configuration Register
0x1010	LFXO_STATUS_SET	RH	LFXO Status Register
0x1014	LFXO_CAL_SET	RW LFSYNC	LFXO Calibration Register
0x1018	LFXO_IF_SET	RWH INTFLAG	Interrupt Flag Register
0x101C	LFXO_IEN_SET	RW	Interrupt Enable Register
0x1020	LFXO_SYNCBUSY_SET	RH	LFXO Sync Busy Register
0x1024	LFXO_LOCK_SET	W	Configuration Lock Register
0x2000	LFXO_IPVERSION_CLR	R	LFXO IP Version
0x2004	LFXO_CTRL_CLR	RW	LFXO Control Register
0x2008	LFXO_CFG_CLR	RW	LFXO Configuration Register
0x2010	LFXO_STATUS_CLR	RH	LFXO Status Register
0x2014	LFXO_CAL_CLR	RW LFSYNC	LFXO Calibration Register
0x2018	LFXO_IF_CLR	RWH INTFLAG	Interrupt Flag Register
0x201C	LFXO_IEN_CLR	RW	Interrupt Enable Register
0x2020	LFXO_SYNCBUSY_CLR	RH	LFXO Sync Busy Register
0x2024	LFXO_LOCK_CLR	W	Configuration Lock Register
0x3000	LFXO_IPVERSION_TGL	R	LFXO IP Version
0x3004	LFXO_CTRL_TGL	RW	LFXO Control Register
0x3008	LFXO_CFG_TGL	RW	LFXO Configuration Register
0x3010	LFXO_STATUS_TGL	RH	LFXO Status Register
0x3014	LFXO_CAL_TGL	RW LFSYNC	LFXO Calibration Register
0x3018	LFXO_IF_TGL	RWH INTFLAG	Interrupt Flag Register
0x301C	LFXO_IEN_TGL	RW	Interrupt Enable Register
0x3020	LFXO_SYNCBUSY_TGL	RH	LFXO Sync Busy Register

Offset	Name	Type	Description
0x3024	LFXO_LOCK_TGL	W	Configuration Lock Register

9.5.5 LFXO Register Description

9.5.5.1 LFXO_IPVERSION - LFXO IP Version

Offset	Bit Position																															
0x000	31	30	29	28	27	26	25	24	23	22	21	20	19	18	17	16	15	14	13	12	11	10	9	8	7	6	5	4	3	2	1	0
Reset																	0x1															
Access																	R															
Name																	IPVERSION															

Bit	Name	Reset	Access	Description
31:0	IPVERSION	0x1	R	IP Version ID
The read only IPVERSION field gives the version for this module. There may be minor software changes required for modules with different values of IPVERSION.				

9.5.5.2 LFXO_CTRL - LFXO Control Register

Offset	Bit Position																															
0x004	31	30	29	28	27	26	25	24	23	22	21	20	19	18	17	16	15	14	13	12	11	10	9	8	7	6	5	4	3	2	1	0
Reset																											0x0	0x0			0x1	0x0
Access																											RW	RW			RW	RW
Name																											FAILDETEM4WUEN	FAILDETEN			DISONDEMAND	FORCEEN

Bit	Name	Reset	Access	Description
31:6	Reserved	To ensure compatibility with future devices, always write Reserved bits to their reset value, unless otherwise stated. More information in 1.2 Conventions		
5	FAILDETEM4WUEN	0x0	RW	LFXO Failure Detection EM4WU Enable Set this bit to enable EM4 exit on the oscillator failure detection.
4	FAILDETEN	0x0	RW	LFXO Failure Detection Enable Set this bit to enable the oscillator failure detection feature. Note that setting this bit will enable the oscillator core.
3:2	Reserved	To ensure compatibility with future devices, always write Reserved bits to their reset value, unless otherwise stated. More information in 1.2 Conventions		
1	DISONDEMAND	0x1	RW	LFXO Disable On-demand requests Set this bit to disable On-demand requests.
0	FORCEEN	0x0	RW	LFXO Force Enable Set this bit to enable the oscillator core. The oscillator core is enabled regardless of On-demand requests.

9.5.5.3 LFXO_CFG - LFXO Configuration Register

Offset	Bit Position																																		
0x008	31	30	29	28	27	26	25	24	23	22	21	20	19	18	17	16	15	14	13	12	11	10	9	8	7	6	5	4	3	2	1	0			
Reset																					0x7						0x0						0x0		0x1
Access																					RW						RW						RW		RW
Name																					TIMEOUT						MODE						HIGHAMPL		AGC

Bit	Name	Reset	Access	Description
31:11	<i>Reserved</i>	<i>To ensure compatibility with future devices, always write Reserved bits to their reset value, unless otherwise stated. More information in 1.2 Conventions</i>		
10:8	TIMEOUT	0x7	RW	LFXO Start-up Delay Configures the start-up delay for LFXO.
	Value	Mode		Description
	0	CYCLES2		Timeout period of 2 cycles
	1	CYCLES256		Timeout period of 256 cycles
	2	CYCLES1K		Timeout period of 1024 cycles
	3	CYCLES2K		Timeout period of 2048 cycles
	4	CYCLES4K		Timeout period of 4096 cycles
	5	CYCLES8K		Timeout period of 8192 cycles
	6	CYCLES16K		Timeout period of 16384 cycles
	7	CYCLES32K		Timeout period of 32768 cycles
7:6	<i>Reserved</i>	<i>To ensure compatibility with future devices, always write Reserved bits to their reset value, unless otherwise stated. More information in 1.2 Conventions</i>		
5:4	MODE	0x0	RW	LFXO Mode Selects the LFXO mode.
	Value	Mode		Description
	0	XTAL		A 32768Hz crystal should be connected to the LF crystal pads. Voltage must not exceed VDDIO.
	1	BUFEXTCLK		An external sine source with minimum amplitude 100mv (zero-to-peak) and maximum amplitude 500mV (zero-to-peak) should be connected in series with LFX TAL_I pin. Minimum voltage should be larger than ground and maximum voltage smaller than VDDIO. The sine source does not need to be ac coupled externally as it is ac couples inside LFXO. LFX TAL_O is free to be used as a general purpose GPIO.
	2	DIGEXTCLK		An external 32KHz CMOS clock should be provided on LFX TAL_I. LFX TAL_O is free to be used as a general purpose GPIO.

Bit	Name	Reset	Access	Description
3:2	<i>Reserved</i>	<i>To ensure compatibility with future devices, always write Reserved bits to their reset value, unless otherwise stated. More information in 1.2 Conventions</i>		
1	HIGHAMPL	0x0	RW	LF XO High Amplitude Enable Set this bit to enable high XTAL oscillation amplitude.
0	AGC	0x1	RW	LF XO AGC Enable Set this bit to enable automatic gain control which limits XTAL oscillation amplitude.

9.5.5.4 LFXO_STATUS - LFXO Status Register

Offset	Bit Position																																
0x010	31	30	29	28	27	26	25	24	23	22	21	20	19	18	17	16	15	14	13	12	11	10	9	8	7	6	5	4	3	2	1	0	
Reset	0x0																0x0																0x0
Access	R																R																R
Name	LOCK																ENS																RDY

Bit	Name	Reset	Access	Description									
31	LOCK	0x0	R	LF XO Locked Status If set, all LFXO lockable registers are locked. <table border="1"> <thead> <tr> <th>Value</th> <th>Mode</th> <th>Description</th> </tr> </thead> <tbody> <tr> <td>0</td> <td>UNLOCKED</td> <td>LF XO lockable registers are not locked</td> </tr> <tr> <td>1</td> <td>LOCKED</td> <td>LF XO lockable registers are locked</td> </tr> </tbody> </table>	Value	Mode	Description	0	UNLOCKED	LF XO lockable registers are not locked	1	LOCKED	LF XO lockable registers are locked
Value	Mode	Description											
0	UNLOCKED	LF XO lockable registers are not locked											
1	LOCKED	LF XO lockable registers are locked											
30:17	<i>Reserved</i>	<i>To ensure compatibility with future devices, always write Reserved bits to their reset value, unless otherwise stated. More information in 1.2 Conventions</i>											
16	ENS	0x0	R	LF XO Enable Status LF XO is enabled.									
15:1	<i>Reserved</i>	<i>To ensure compatibility with future devices, always write Reserved bits to their reset value, unless otherwise stated. More information in 1.2 Conventions</i>											
0	RDY	0x0	R	LF XO Ready Status LF XO is enabled and start-up time has exceeded.									

9.5.5.5 LFXO_CAL - LFXO Calibration Register

Offset	Bit Position																																
0x014	31	30	29	28	27	26	25	24	23	22	21	20	19	18	17	16	15	14	13	12	11	10	9	8	7	6	5	4	3	2	1	0	
Reset																								0x1				0x0					
Access																								RW				RW					
Name																								GAIN				CAPTUNE					

Bit	Name	Reset	Access	Description
31:10	Reserved	<i>To ensure compatibility with future devices, always write Reserved bits to their reset value, unless otherwise stated. More information in 1.2 Conventions</i>		
9:8	GAIN	0x1	RW	LFXO Startup Gain The optimal value depends on the chosen crystal.
7	Reserved	<i>To ensure compatibility with future devices, always write Reserved bits to their reset value, unless otherwise stated. More information in 1.2 Conventions</i>		
6:0	CAPTUNE	0x0	RW	Internal Capacitance Tuning Program internal load capacitance connected between X_N pin and ground and X_P pin and ground. The bus affects tuning capacitances on both pins symmetrically. CAPTUNE value must not exceed 0x4F. When updating CAPTUNE, its value must only be incremented or decremented by 1 which provides a tuning step of 0.25pF. The maximum value is estimated to be 20pF. Please refer to the device Datasheet for more information.

9.5.5.6 LFXO_IF - Interrupt Flag Register

Offset	Bit Position																															
0x018	31	30	29	28	27	26	25	24	23	22	21	20	19	18	17	16	15	14	13	12	11	10	9	8	7	6	5	4	3	2	1	0
Reset																	0x0	0x0	0x0	0x0												
Access																	RW	RW	RW	RW												
Name																	FAIL	NEGEDGE	POSEDGE	RDY												

Bit	Name	Reset	Access	Description
31:4	Reserved	<i>To ensure compatibility with future devices, always write Reserved bits to their reset value, unless otherwise stated. More information in 1.2 Conventions</i>		
3	FAIL	0x0	RW	LFXO Failure Interrupt Flag Set when LFXO failure is detected. Write 1 to clear the interrupt flag.
2	NEGEDGE	0x0	RW	Falling Edge Interrupt Flag Triggers on every negative edge of the LFXO clock.
1	POSEDGE	0x0	RW	Rising Edge Interrupt Flag Triggers on every positive edge of the LFXO clock.
0	RDY	0x0	RW	LFXO Ready Interrupt Flag Set when LFXO is ready (start-up time exceeded). Write 1 to clear the interrupt flag.

9.5.5.7 LFXO_IEN - Interrupt Enable Register

Offset	Bit Position																															
0x01C	31	30	29	28	27	26	25	24	23	22	21	20	19	18	17	16	15	14	13	12	11	10	9	8	7	6	5	4	3	2	1	0
Reset																											0x0	0x0	0x0	0x0		
Access																											RW	RW	RW	RW		
Name																											FAIL	NEGEDGE	POSEDGE	RDY		

Bit	Name	Reset	Access	Description
31:4	Reserved	To ensure compatibility with future devices, always write Reserved bits to their reset value, unless otherwise stated. More information in 1.2 Conventions		
3	FAIL Write 1 to enable FAILIF	0x0	RW	LFXO Failure Interrupt Enable
2	NEGEDGE Write 1 to enable NEGEDGEIF.	0x0	RW	Falling Edge Interrupt Enable
1	POSEDGE Write 1 to enable POSEDGEIF.	0x0	RW	Rising Edge Interrupt Enable
0	RDY Write 1 to enable RDYIF.	0x0	RW	LFXO Ready Interrupt Enable

9.5.5.8 LFXO_SYNCBUSY - LFXO Sync Busy Register

Offset	Bit Position																															
0x020	31	30	29	28	27	26	25	24	23	22	21	20	19	18	17	16	15	14	13	12	11	10	9	8	7	6	5	4	3	2	1	0
Reset																											0x0					
Access																											R					
Name																											CAL					

Bit	Name	Reset	Access	Description
31:1	Reserved	To ensure compatibility with future devices, always write Reserved bits to their reset value, unless otherwise stated. More information in 1.2 Conventions		
0	CAL This bit is set when there is an ongoing synchronization of CAL register bitfields. Do not write to CAL register while this bit is set.	0x0	R	LFXO Synchronization status

9.5.5.9 LFXO_LOCK - Configuration Lock Register

Offset	Bit Position																															
0x024	31	30	29	28	27	26	25	24	23	22	21	20	19	18	17	16	15	14	13	12	11	10	9	8	7	6	5	4	3	2	1	0
Reset																	0x1A20															
Access																	W															
Name																	LOCKKEY															

Bit	Name	Reset	Access	Description
31:16	Reserved	To ensure compatibility with future devices, always write Reserved bits to their reset value, unless otherwise stated. More information in 1.2 Conventions		
15:0	LOCKKEY	0x1A20	W	Lock Key Write any other value than UNLOCK to lock CTRL, CFG and CAL registers. Write UNLOCK value to unlock the registers.
	Value	Mode		Description
	6688	UNLOCK		Unlock LFXO lockable registers

9.6 LFRCO - Low-Frequency RC Oscillator

9.6.1 Introduction

The LFRCO is an integrated low-frequency (32.768 kHz) RC oscillator. It can be used as a timing reference in EM0, EM1, EM2, and EM4. On certain part numbers, a precision mode is available in EM0, EM1 and EM2. Precision mode enables hardware that periodically recalibrates the LFRCO against the HFXO crystal frequency when temperature changes to provide a fully internal 32.768 kHz clock source with +/-500 ppm accuracy. Consult the device data sheet for details on which part numbers support precision mode.

9.6.2 Features

- 32.768 kHz oscillator
- High Accuracy
- Precision mode available in EM0, EM1, and EM2.
- Low-power non-precision operation available in EM0, EM1, EM2, and EM4.
- On-demand
- Lockable registers

9.6.3 Functional Description

9.6.3.1 Start-up

The LFRCO has a fast start-up time (refer to the data sheet electrical specifications for the exact start-up time). When the oscillator has started up and is ready to use, the RDY status bit will go high and the RDY interrupt will be triggered. After start-up, it may take two clock cycles for the clock to propagate through the CMU to the peripherals.

9.6.3.2 On-Demand Clocking

Software may forcefully enable the LFRCO by setting the LFRCO_CTRL.FORCEEN bit field. However, by default, the LFRCO is configured to be enabled only when required by hardware, and to shut down when no hardware request is present (i.e. LFRCO_CTRL.DISONDEMAND=0 and LFRCO_CTRL.FORCEEN=0). This is known as on-demand clocking and allows the oscillator to be controlled without any software intervention.

9.6.3.3 Register Lock

The LFRCO configuration registers NOMCAL, NOMCALINV and CFG can be locked or unlocked by software using the LOCKKEY field in the LFRCO_LOCK register. By writing the UNLOCK value to LFRCO_LOCK_LOCKKEY, these registers will be unlocked and accessible to software. Any other value written to LFRCO_LOCK_LOCKKEY will lock the registers against write operations.

9.6.3.4 Precision Mode

Certain device families support a precision mode to bring the LFRCO accuracy to within +/-500 ppm, suitable for BLE sleep applications. Precision mode uses hardware to automatically re-calibrate the LFRCO against a crystal driven by the HFXO. Hardware detects temperature changes and initiates a re-calibration of the LFRCO as needed when operating in EM0, EM1, or EM2. If a re-calibration is necessary and the HFXO is not active, the precision mode hardware will automatically enable HFXO for a short time to perform the calibration. EM4 operation is not allowed while precision mode is enabled.

To enable precision mode software should set the LFRCO_CFG_HIGHPRECEN bit to 1 while the LFRCO is disabled (LFRCO_STATUS_ENS = 0). If this bit is written while the oscillator is enabled, a bus fault will be generated. In a typical application, software will only access HIGHPRECEN at startup before any peripherals are configured to request the LFRCO.

Disabling precision mode is the inverse - software should ensure that no peripherals are requesting the LFRCO, and then clear the LFRCO_CFG_HIGHPRECEN bit to 0.

9.6.3.4.1 Reference Frequency

Precision mode uses a reference clock from the HFXO as a calibration target. Two registers (LFRCO_NOMCALCNT and LFRCO_NOMCALCNTINV) are used to specify the nominal relationship between the HFXO reference clock and the LFRCO frequency as shown in [Figure 9.2 LFRCO_NOMCALCNT Calculation on page 244](#) and [Figure 9.3 LFRCO_NOMCALCNTINV Calculation on page 244](#). NOMCALCNT and NOMCALCNTINV must be programmed while the LFRCO is not enabled.

$$\text{NOMCALCNT} = (320 * f_{\text{HFXO}}) / 32768$$

Where f_{HFXO} is the reference crystal frequency in Hz

Figure 9.2. LFRCO_NOMCALCNT Calculation

$$\text{NOMCALCNTINV} = (1 / \text{NOMCALCNT}) * 2^{33}$$

Figure 9.3. LFRCO_NOMCALCNTINV Calculation

9.6.3.4.2 Temperature Check and Calibration Intervals

When starting up in precision mode, the LFRCO will calibrate itself against the HFXO. After startup, the die temperature is checked periodically and if necessary, the LFRCO will initiate a re-calibration. Periodic re-calibration is also performed if the temperature has not changed for an extended period of time.

If a very high die temperature gradient is expected (e.g. due to high-power RF transmission), software can reduce the temperature check interval temporarily by setting the LFRCO_CMD_REDUCECINT bit to 1. The LFRCO will then use a shorter temperature check interval until the chip enters EM2. When EM2 is entered, the temperature-check interval will gradually be increased based on the measured temperature gradient until it is back to the normal temperature check interval.

9.6.3.5 Interrupts

The LFRCO implements several interrupt flags in the LFRCO_IF register to report status, error events, or for debugging. Each interrupt flag has an enable bit in LFRCO_IEN. Setting a bit in IEN to 1 enables the corresponding interrupt source to trigger an LFRCO interrupt.

RDYIF is triggered after start-up, when the LFRCO startup sequence is complete and the oscillator is ready to use.

POSEDGEIF and NEGEDGEIF are triggered by the rising and falling edge of LFRCO respectively. These flags will only get set if either of the interrupts are enabled (with POSEDGEIEN or NEGEDGEIEN). Note that enabling NEGEDGEIF or POSEDGEIF act as a clock requester for the LFRCO oscillator, and these two interrupt enables must be disabled in order to disable the LFRCO.

RDYIF, POSEDGEIF, and NEGEDGEIF are available only in EM0 and EM1.

Three of the interrupt sources are error flags used by precision mode to alert software that there is a problem with the oscillator and it may no longer be running with full precision. CALOORIF indicates that a calibration was performed, but the result was outside of the oscillator's adjustment range. TCOORIF indicates that a temperature measurement was performed, but the measurement was out of range. Finally, the SCHEDERRIF flag indicates that a temperature check could not be performed due to a prior error. These three error flags are available when operating in precision mode in EM0, EM1, or EM2.

The remaining flags, TEMPCHANGEIF, CALDONEIF and TCDONEIF are available when operating in precision mode in EM0 and EM1 only and are provided for debugging purposes. Refer to the LFRCO_IF register description for the specific conditions of these flags.

9.6.4 LFRCO Register Map

The offset register address is relative to the registers base address.

Offset	Name	Type	Description
0x000	LFRCO_IPVERSION	R	IP Version
0x004	LFRCO_CTRL	RW	Control Register
0x008	LFRCO_STATUS	RH	Status Register
0x014	LFRCO_IF	RWH INTFLAG	Interrupt Flag Register
0x018	LFRCO_IEN	RW	Interrupt Enable Register
0x020	LFRCO_LOCK	W	Configuration Lock Register
0x024	LFRCO_CFG	RW CONFIG	Configuration Register
0x02C	LFRCO_NOMCAL	RW CONFIG	Nominal Calibration Register
0x030	LFRCO_NOMCALINV	RW CONFIG	Nominal Calibration Inverted Register
0x034	LFRCO_CMD	W	Command Register
0x1000	LFRCO_IPVERSION_SET	R	IP Version
0x1004	LFRCO_CTRL_SET	RW	Control Register
0x1008	LFRCO_STATUS_SET	RH	Status Register
0x1014	LFRCO_IF_SET	RWH INTFLAG	Interrupt Flag Register
0x1018	LFRCO_IEN_SET	RW	Interrupt Enable Register
0x1020	LFRCO_LOCK_SET	W	Configuration Lock Register
0x1024	LFRCO_CFG_SET	RW CONFIG	Configuration Register
0x102C	LFRCO_NOMCAL_SET	RW CONFIG	Nominal Calibration Register
0x1030	LFRCO_NOMCALINV_SET	RW CONFIG	Nominal Calibration Inverted Register
0x1034	LFRCO_CMD_SET	W	Command Register
0x2000	LFRCO_IPVERSION_CLR	R	IP Version
0x2004	LFRCO_CTRL_CLR	RW	Control Register
0x2008	LFRCO_STATUS_CLR	RH	Status Register
0x2014	LFRCO_IF_CLR	RWH INTFLAG	Interrupt Flag Register
0x2018	LFRCO_IEN_CLR	RW	Interrupt Enable Register
0x2020	LFRCO_LOCK_CLR	W	Configuration Lock Register
0x2024	LFRCO_CFG_CLR	RW CONFIG	Configuration Register
0x202C	LFRCO_NOMCAL_CLR	RW CONFIG	Nominal Calibration Register
0x2030	LFRCO_NOMCALINV_CLR	RW CONFIG	Nominal Calibration Inverted Register
0x2034	LFRCO_CMD_CLR	W	Command Register
0x3000	LFRCO_IPVERSION_TGL	R	IP Version
0x3004	LFRCO_CTRL_TGL	RW	Control Register
0x3008	LFRCO_STATUS_TGL	RH	Status Register
0x3014	LFRCO_IF_TGL	RWH INTFLAG	Interrupt Flag Register
0x3018	LFRCO_IEN_TGL	RW	Interrupt Enable Register

Offset	Name	Type	Description
0x3020	LFRCO_LOCK_TGL	W	Configuration Lock Register
0x3024	LFRCO_CFG_TGL	RW CONFIG	Configuration Register
0x302C	LFRCO_NOMCAL_TGL	RW CONFIG	Nominal Calibration Register
0x3030	LFRCO_NOMCALINV_TGL	RW CONFIG	Nominal Calibration Inverted Register
0x3034	LFRCO_CMD_TGL	W	Command Register

9.6.5 LFRCO Register Description

9.6.5.1 LFRCO_IPVERSION - IP Version

Offset	Bit Position																															
0x000	31	30	29	28	27	26	25	24	23	22	21	20	19	18	17	16	15	14	13	12	11	10	9	8	7	6	5	4	3	2	1	0
Reset																	0x2															
Access																	R															
Name																	IPVERSION															

Bit	Name	Reset	Access	Description
31:0	IPVERSION	0x2	R	IP version ID The read only IPVERSION field gives the version for this module. There may be minor software changes required for modules with different values of IPVERSION.

9.6.5.2 LFRCO_CTRL - Control Register

Offset	Bit Position																															
0x004	31	30	29	28	27	26	25	24	23	22	21	20	19	18	17	16	15	14	13	12	11	10	9	8	7	6	5	4	3	2	1	0
Reset																											0x0	0x0				
Access																											RW	RW				
Name																											DISONDEMAND	FORCEEN				

Bit	Name	Reset	Access	Description
31:2	<i>Reserved</i>	<i>To ensure compatibility with future devices, always write Reserved bits to their reset value, unless otherwise stated. More information in 1.2 Conventions</i>		
1	DISONDEMAND	0x0	RW	Disable On-Demand Disable on demand functionality and enable the oscillator based on the force-enable bit.
0	FORCEEN	0x0	RW	Force Enable Force the LFRCO core on

9.6.5.3 LFRCO_STATUS - Status Register

Offset	Bit Position																															
0x008	31	30	29	28	27	26	25	24	23	22	21	20	19	18	17	16	15	14	13	12	11	10	9	8	7	6	5	4	3	2	1	0
Reset	0x0															0x0															0x0	
Access	R															R															R	
Name	LOCK															ENS															RDY	

Bit	Name	Reset	Access	Description									
31	LOCK	0x0	R	Lock Status This bit is set when LFRCO is locked. <table border="1"> <thead> <tr> <th>Value</th> <th>Mode</th> <th>Description</th> </tr> </thead> <tbody> <tr> <td>0</td> <td>UNLOCKED</td> <td>Access to configuration registers not locked</td> </tr> <tr> <td>1</td> <td>LOCKED</td> <td>Access to configuration registers locked</td> </tr> </tbody> </table>	Value	Mode	Description	0	UNLOCKED	Access to configuration registers not locked	1	LOCKED	Access to configuration registers locked
Value	Mode	Description											
0	UNLOCKED	Access to configuration registers not locked											
1	LOCKED	Access to configuration registers locked											
30:17	<i>Reserved</i>	<i>To ensure compatibility with future devices, always write Reserved bits to their reset value, unless otherwise stated. More information in 1.2 Conventions</i>											
16	ENS	0x0	R	Enabled Status This bit is set when LFRCO is enabling the analog core.									
15:1	<i>Reserved</i>	<i>To ensure compatibility with future devices, always write Reserved bits to their reset value, unless otherwise stated. More information in 1.2 Conventions</i>											
0	RDY	0x0	R	Ready Status This bit is set when qualification is done and LFRCO is ready.									

9.6.5.4 LFRCO_IF - Interrupt Flag Register

Offset	Bit Position																																					
0x014	31	30	29	28	27	26	25	24	23	22	21	20	19	18	17	16	15	14	13	12	11	10	9	8	7	6	5	4	3	2	1	0						
Reset														0x0	0x0	0x0											0x0	0x0	0x0							0x0	0x0	0x0
Access														RW	RW	RW											RW	RW	RW							RW	RW	RW
Name														CALOOR	TCOOR	SCHEDERR											TEMPCHANGE	CALDONE	TCDONE							NEGEDGE	POSEDGE	RDY

Bit	Name	Reset	Access	Description
31:19	<i>Reserved</i>	<i>To ensure compatibility with future devices, always write Reserved bits to their reset value, unless otherwise stated. More information in 1.2 Conventions</i>		
18	CALOOR	0x0	RW	Calibration Out Of Range Flag Triggers if Calibration measure is out of range
17	TCOOR	0x0	RW	Temperature Check Out Of Range Flag Triggers if Temperature Check measure is out of range
16	SCHEDERR	0x0	RW	Scheduling Error Flag Triggers if a scheduled Temperature Check can not be handled because prior Temperature Check or Calibration did not complete.
15:11	<i>Reserved</i>	<i>To ensure compatibility with future devices, always write Reserved bits to their reset value, unless otherwise stated. More information in 1.2 Conventions</i>		
10	TEMPCHANGE	0x0	RW	Temperature Change Flag Triggers when Temperature Check detects a change in temperature
9	CALDONE	0x0	RW	Calibration Done Flag Triggers on completion of Calibration
8	TCDONE	0x0	RW	Temperature Check Done Flag Triggers on completion of Temperature Check
7:3	<i>Reserved</i>	<i>To ensure compatibility with future devices, always write Reserved bits to their reset value, unless otherwise stated. More information in 1.2 Conventions</i>		
2	NEGEDGE	0x0	RW	Falling Edge Flag Triggers on every negative edge of the LFRCO clock. IF will only be set when corresponding IEN is set.
1	POSEDGE	0x0	RW	Rising Edge Flag Triggers on every positive edge of the LFRCO clock. IF will only be set when corresponding IEN is set.
0	RDY	0x0	RW	Ready Flag Triggers when the oscillator becomes ready

9.6.5.5 LFRCO_IEN - Interrupt Enable Register

Offset	Bit Position																																				
0x018	31	30	29	28	27	26	25	24	23	22	21	20	19	18	17	16	15	14	13	12	11	10	9	8	7	6	5	4	3	2	1	0					
Reset														0x0	0x0	0x0											0x0	0x0	0x0						0x0	0x0	0x0
Access														RW	RW	RW											RW	RW	RW						RW	RW	RW
Name														CALOOR	TCOOR	SCHEDERR											TEMPCHANGE	CALDONE	TCDONE						NEGEDGE	POSEDGE	RDY

Bit	Name	Reset	Access	Description
31:19	<i>Reserved</i>	<i>To ensure compatibility with future devices, always write Reserved bits to their reset value, unless otherwise stated. More information in 1.2 Conventions</i>		
18	CALOOR	0x0	RW	Calibration Out Of Range Enable Enables the Calibration Out Of Range interrupt
17	TCOOR	0x0	RW	Temperature Check Out Of Range Enable Enables the Temperature Check Out Of Range interrupt
16	SCHEDERR	0x0	RW	Scheduling Error Enable Enables the Scheduling Error interrupt
15:11	<i>Reserved</i>	<i>To ensure compatibility with future devices, always write Reserved bits to their reset value, unless otherwise stated. More information in 1.2 Conventions</i>		
10	TEMPCHANGE	0x0	RW	Temperature Change Enable Enables the Temperature Change interrupt
9	CALDONE	0x0	RW	Calibration Done Enable Enables the Calibration Done interrupt
8	TCDONE	0x0	RW	Temperature Check Done Enable Enables the Temperature Check Done interrupt
7:3	<i>Reserved</i>	<i>To ensure compatibility with future devices, always write Reserved bits to their reset value, unless otherwise stated. More information in 1.2 Conventions</i>		
2	NEGEDGE	0x0	RW	Falling Edge Enable Enables the negedge interrupt and will cause the oscillator to run
1	POSEDGE	0x0	RW	Rising Edge Enable Enables the posedge interrupt and will cause the oscillator to run
0	RDY	0x0	RW	Ready Enable Enables the ready interrupt

9.6.5.6 LFRCO_LOCK - Configuration Lock Register

Offset	Bit Position																															
0x020	31	30	29	28	27	26	25	24	23	22	21	20	19	18	17	16	15	14	13	12	11	10	9	8	7	6	5	4	3	2	1	0
Reset																	0x0															
Access																	W															
Name																	LOCKKEY															

Bit	Name	Reset	Access	Description
31:16	Reserved	To ensure compatibility with future devices, always write Reserved bits to their reset value, unless otherwise stated. More information in 1.2 Conventions		
15:0	LOCKKEY	0x0	W	Lock Key Writing the lock key will unlock the LFRCO configuration registers. Writing any other value will lock them.
	Value	Mode	Description	
	0	LOCK	Lock Configuration Registers	
	3987	UNLOCK	Unlock Configuration Registers	

9.6.5.7 LFRCO_CFG - Configuration Register

Offset	Bit Position																															
0x024	31	30	29	28	27	26	25	24	23	22	21	20	19	18	17	16	15	14	13	12	11	10	9	8	7	6	5	4	3	2	1	0
Reset																																0x0
Access																																RW
Name																																HIGHPRECEN

Bit	Name	Reset	Access	Description
31:1	Reserved	To ensure compatibility with future devices, always write Reserved bits to their reset value, unless otherwise stated. More information in 1.2 Conventions		
0	HIGHPRECEN	0x0	RW	High Precision Enable LFRCO operates in High Precision Mode when this bit is set. HIGHPRECEN should not be written while LFRCO is enabled.

9.6.5.8 LFRCO_NOMCAL - Nominal Calibration Register

Offset	Bit Position																															
0x02C	31	30	29	28	27	26	25	24	23	22	21	20	19	18	17	16	15	14	13	12	11	10	9	8	7	6	5	4	3	2	1	0
Reset																	0x5B8D8															
Access																	RW															
Name																	NOMCALCNT															

Bit	Name	Reset	Access	Description
31:21	Reserved	To ensure compatibility with future devices, always write Reserved bits to their reset value, unless otherwise stated. More information in 1.2 Conventions		
20:0	NOMCALCNT	0x5B8D8	RW	Nominal Calibration Count Expected Calibration count value. Should be set based on HFXO frequency; $NOMCALCNT = 2 * f(HFXO) / (32.768 \text{ kHz} / 160)$. Default value corresponds to 38.4 MHz HFXO frequency. NOMCALCNT should not be written while LFRCO is enabled.

9.6.5.9 LFRCO_NOMCALINV - Nominal Calibration Inverted Register

Offset	Bit Position																															
0x030	31	30	29	28	27	26	25	24	23	22	21	20	19	18	17	16	15	14	13	12	11	10	9	8	7	6	5	4	3	2	1	0
Reset																	0x597A															
Access																	RW															
Name																	NOMCALCNTINV															

Bit	Name	Reset	Access	Description
31:17	Reserved	To ensure compatibility with future devices, always write Reserved bits to their reset value, unless otherwise stated. More information in 1.2 Conventions		
16:0	NOMCALCNTINV	0x597A	RW	Nominal Calibration Count Inverted This register should always be set to the inverse of NOMCALCNT value. Due to format of this register, integer value should be $NOMCALCNTINV = (1 / NOMCALCNT) * (2^{**33})$. NOMCALCNTINV should not be written while LFRCO is enabled.

9.6.5.10 LFRCO_CMD - Command Register

Offset	Bit Position																															
0x034	31	30	29	28	27	26	25	24	23	22	21	20	19	18	17	16	15	14	13	12	11	10	9	8	7	6	5	4	3	2	1	0
Reset																																0x0
Access																																W(nB)
Name																																REDUCETCINT

Bit	Name	Reset	Access	Description
31:1	Reserved	To ensure compatibility with future devices, always write Reserved bits to their reset value, unless otherwise stated. More information in 1.2 Conventions		
0	REDUCETCINT	0x0	W(nB)	Reduce Temperature Check Interval Setting this register field will temporarily lower the Temperature Check interval.

9.7 FSRCO - Fast Start RCO

9.7.1 Introduction

This is an RC oscillator which can start and stop very fast. It is a fixed frequency oscillator, with no frequency configurability and as such any user of this clock can rely on it being a specific frequency independent of the system state. This is the first oscillator used during power up and hence it minimizes dependency to other blocks.

9.7.2 Features

- 20 MHz nominal frequency
- Low energy consumption

9.7.3 Functional Description

There are no programmable registers in this module. Software can choose to use this as system clock in the CMU block. the only way to enable or disable the FSRCO is by requesting it as a clock source in the CMU clock select registers.

9.7.4 FSRCO Register Map

The offset register address is relative to the registers base address.

Offset	Name	Type	Description
0x000	FSRCO_IPVERSION	R	IP Version
0x1000	FSRCO_IPVERSION_SET	R	IP Version
0x2000	FSRCO_IPVERSION_CLR	R	IP Version
0x3000	FSRCO_IPVERSION_TGL	R	IP Version

9.7.5 FSRCO Register Description

9.7.5.1 FSRCO_IPVERSION - IP Version

Offset	Bit Position																															
0x000	31	30	29	28	27	26	25	24	23	22	21	20	19	18	17	16	15	14	13	12	11	10	9	8	7	6	5	4	3	2	1	0
Reset																	0x0															
Access																	R															
Name																	IPVERSION															

Bit	Name	Reset	Access	Description
31:0	IPVERSION	0x0	R	IP Version
The read only IPVERSION field gives the version for this module. There may be minor software changes required for modules with different values of IPVERSION.				

9.8 ULFRCO - Ultra Low Frequency RC Oscillator

9.8.1 Introduction

The ULFRCO is an ultra low power 1 kHz oscillator which is available in all energy modes. The ULFRCO is available to many low-frequency peripherals as a lower power alternative to one of the 32 kHz oscillators. This oscillator is also used for internal bias and housekeeping tasks in EM0-EM3.

9.8.2 Features

- 1 kHz nominal frequency
- Low energy consumption

9.8.3 Functional Description

There are no user programmable registers in this module. The oscillator is always on in all energy modes except EM4. In EM4, the oscillator is available on-demand by peripheral requests.

10. SMU - Security Management Unit

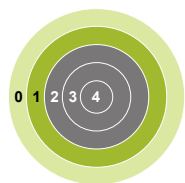

Quick Facts

What?

The Security Management Unit (SMU) provides configuration and status reporting for ARM TrustZone on the EFR32xG24.

Why?

Enables a robust solution at the system level.

How?

Hardware context switching and enhanced security provided by ARM TrustZone. Extension of the ARM MPU to control peripheral access.

10.1 Introduction

The Security Management Unit is used to configure and extend TrustZone bus level security provided by the Cortex®-M33. In addition it increases the effective MPU regions by providing MPU control over peripheral access.

10.2 Features

- Per peripheral privileged and secure attributes
- Per manager privileged and secure attributes
- Separate interrupt flags for privileged, secure, or instruction access exceptions.
- Separate interrupt flag for secure manager access exceptions
- Secure and Privileged exception IRQs
- Configurable secure, non-secure, and non-secure-callable memory regions.

10.3 Functional Description

10.3.1 Bus Level Security

Bus level security is the ability to control the flow of information on the device. The components of bus level security are the Cortex®-M33, the Bus Manager Protect Unit (BMPU), and the Peripheral Protection Unit (PPU) as highlighted in [Figure 10.1 Bus Level Security Implementation on page 257](#). The SMU controls and configures all the components used in bus level security.

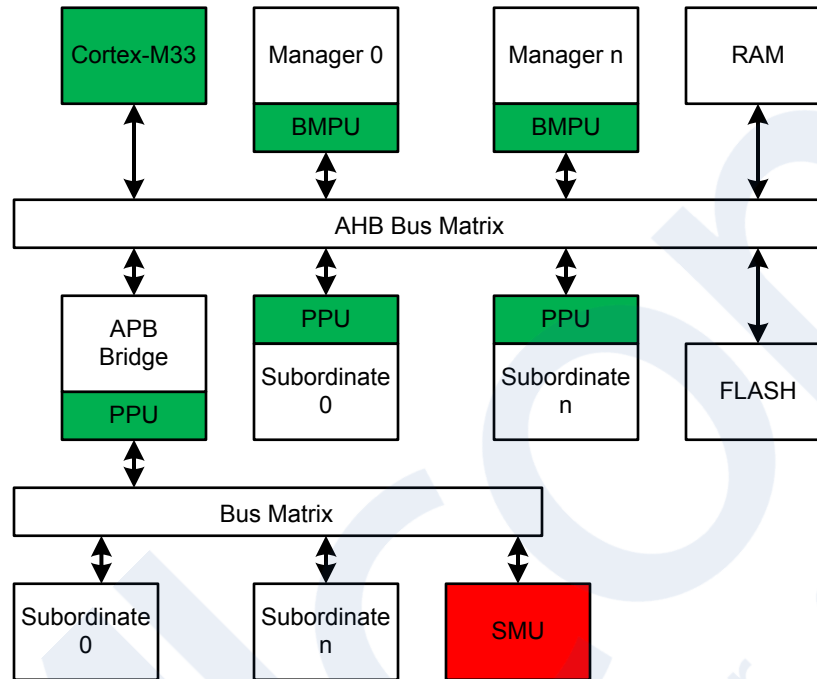

Figure 10.1. Bus Level Security Implementation

The BMPU is responsible for preventing managers (CPU, DMA, Etc..) from accessing secure addresses without authorization. For example, if a DMA configured as non-secure tries to access memory that is marked secure the BMPU will prevent access and set the corresponding interrupt flag. The BMPU prevents access of secure addresses by non-secure managers. The Cortex®-M33 has BMPU functionality built into the TrustZone implementation.

The PPU is primarily responsible for blocking access to privileged peripherals from unprivileged managers. In addition, it also ensures that secure and non-secure peripherals are only accessible at the appropriate secure or non-secure addresses as described in [10.3.6 Configuring Peripherals](#).

Since FLASH and RAM have no PPU, bus managers of any privilege state may access those resources. The Cortex®-M33 has an MPU which prevents execution of privileged memory when the CPU is in an unprivileged state. For more information on the MPU refer to the ARM Cortex®-M33 documentation.

10.3.2 Privileged Access Control

The Cortex®-M33 and all other managers can be in either the privileged or unprivileged state. All bus access to peripherals are tested for privilege level by the PPU and resolved as shown in [Table 10.1 Privileged Access Table on page 258](#).

If an exception is detected on a write, the write will be ignored and the appropriate interrupt flag set. If an exception is detected on a read 0x0 will be returned and the appropriate interrupt flag set.

Table 10.1. Privileged Access Table

Manager Attribute	Peripheral Attribute	Result
privileged	privileged	Success
privileged	unprivileged	Success
unprivileged	privileged	Exception
unprivileged	unprivileged	Success

10.3.3 Secure Access Control

The Cortex®-M33 and all other managers can be in either the secure or non-secure state. All bus accesses are tested for security status by the BMPUs and PPU and resolve as shown in [Table 10.2 Secure Access Table on page 258](#). Secure access is computed using the secure attribute of the manager and the address region being accessed. If a peripheral is being accessed, the secure attribute of the peripheral is also used. For more information on the relationship between the address regions and peripheral security attributes please see [10.3.6 Configuring Peripherals](#)

If an exception is detected on a write the write will be ignored and the appropriate interrupt flag set. If an exception is detected on a read 0x0 will be returned and the appropriate interrupt flag set.

Table 10.2. Secure Access Table

Manager Attribute	Address Attribute	Peripheral Attribute	Result
secure	secure	N/A	Success
secure	secure	secure	Success
secure	secure	non-secure	Exception
secure	non-secure	N/A	Exception
secure	non-secure	secure	Exception
secure	non-secure	non-secure	Success
non-secure	secure	N/A	Exception
non-secure	secure	secure	Exception
non-secure	secure	non-secure	Exception
non-secure	non-secure	N/A	Success
non-secure	non-secure	secure	Exception
non-secure	non-secure	non-secure	Success

10.3.4 ARM TrustZone

ARM TrustZone is used to control what addresses are accessible by the CPU at any given time. There are two security states: secure and non-secure. In addition the MPU provides two privilege levels: privileged and unprivileged. This results in 4 possible states: secure-privileged, non-secure-privileged, secure-unprivileged and non-secure-unprivileged.

Non-secure code may not directly call secure code. To call secure code, non-secure code must first call a shim located in specially marked non-secure-callable memory. Unprivileged code may invoke privileged code and change the processor state to privileged by either issuing an SVC instruction or taking an interrupt. The processor is returned to unprivileged state when software manually reconfigures the security state or exits an interrupt.

For more information on secure/non-secure and privileged/unprivileged state transitions see the ARM Cortex®-M33 documentation.

There are two primary use cases for TrustZone and the MPU. The first is simply partitioning a monolithic application in to the 4 states to protect some pieces of the system from bugs or attacks on others. The second is to use a RTOS to isolate several tasks from each other. In this case the RTOS itself normally consumes the privileged states with all other code running in the unprivileged states. Whenever a task switch occurs the RTOS can reconfigure the device so the new task has access to only the components it requires, protecting other tasks from interference.

In both use cases the TrustZone and MPU feature of the Cortex®-M33 both secures and accelerates mode transitions while the SMU provides the ability to configure the security and privilege attributes of peripherals and memory.

The core is in secure-privileged state after a reset.

10.3.5 Configuring Managers

The SMU provides the ability to configure the current secure and privileged attribute of all bus managers except for the CPU which is controlled as described in [10.3.4 ARM TrustZone](#).

To configure the privileged attribute of a manager set the appropriate bit in SMU_BMPUPATDn. To configure the secure attribute of a manager set the appropriate bit in SMU_BMPUPSATDn.

10.3.6 Configuring Peripherals

The SMU provides the ability to configure the current secure and privileged state of all peripherals. To configure the privileged attribute of a peripheral set the appropriate bit in SMU_PPUPATDn.

Each peripheral is accessible at one of two addresses: A secure address and an non-secure address. Which address is valid depends on the security attribute of the peripheral configured in the SMU. When configured as secure a peripheral may only be accessed at its secure address and when configured as non-secure the peripheral may only be accessed at its non-secure address. This forces code to be aware of the security attribute of the peripheral being accessed, preventing secure code from accessing a non-secure peripheral unintentionally.

The device memory map contains 4 regions of fixed length and fixed security attribute to facilitate the secure access of peripherals and RF peripherals. There is one secure (0x40000000) and one non-secure (0x50000000) region for peripherals and one secure (0xA0000000) and non-secure (0xB0000000) region for the radio subsystem. While each peripheral can be configured independently the radio subsystem is configured as a unit.

To configure the security attribute of a peripheral set the appropriate bit in SMU_PPUSATDn.

10.3.7 Configuring Memory

The SMU provides the ability to configure the security attribute of memory. There are 13 configurable regions in total. There are three regions in FLASH (0 - 2) and three in RAM (4-6) which have pre-determined secure attributes and user selectable sizes. Regions 3 and 11 cover the flash info page and ARM EPPB space respectively and have a fixed size. These regions can be configured as secure or non-secure by setting ESAUR3NS in SMU_ESAURTYPES0 and ESAUR11NS in SMU_ESAURTYPES1 respectively.

The size of the FLASH and RAM regions are controlled by the SMU_ESAUMRBRxy registers as shown in [Table 10.3 Memory Configuration Regions on page 260](#). Region sizes are adjusted in 4 kB increments with the lower 12 bits of SMU_ESAUMRBRxy ignored. The non-secure-callable regions may be set to size 0 but secure and non-secure regions must be at least 4 kB.

Table 10.3. Memory Configuration Regions

Region	Memory	Attributes	Start	End
0	FLASH	secure	0x00000000	SMU_ESAUMRBR01-1
1	FLASH	non-secure-callable	SMU_ESAUMRBR01	SMU_ESAUMRBR12-1
2	FLASH	non-secure	SMU_ESAUMRBR12	0x0FDFFFFFFF
3	FLASH (info page)	secure or non-secure	0x0FE00000	0x0FFFFFFF
4	RAM	secure	0x20000000	SMU_ESAUMRBR45-1
5	RAM	non-secure-callable	SMU_ESAUMRBR45	SMU_ESAUMRBR56-1
6	RAM	non-secure	SMU_ESAUMRBR56	0x2FFFFFFF
7	Peripherals	secure	0x40000000	0x4FFFFFFF
8	Peripherals	non-secure	0x50000000	0x5FFFFFFF
9	SEQRAM/ FRCRAM	secure	0xA0000000	0xAFFFFFFF
10	SEQRAM/ FRCRAM	non-secure	0xB0000000	0xBFFFFFFF
11	EPPB	secure or non-secure	0xE0044000	0xE00DFFF
12	Cortex®-M33 Processor ROM table	exempt	0xE00FE000	0xE00FEFFF

10.3.8 Cortex®-M33 Integration

In addition to the SMU based access controls the Cortex®-M33 has additional security features for controlling both secure and privileged access.

The Security Attribution Unit (SAU) provides that ability to setup secure memory regions in addition to those configured by the SMU. To disable the SAU and rely entirely on the SMU for security management clear ENABLE and set ALLNS in the SAU CTRL register. To enable a combination of SMU and SAU control set ENABLE in the SAU CTRL register. If both ENABLE and ALLNS are cleared all Cortex®-M33 will treat all transactions as secure.

When both SAU and SMU are in use, a memory address is considered secure if either the SAU or SMU have it configured as secure. When enabled the SAU applies ONLY to access by the Cortex®-M33 and does not effect any other managers. For more information on the SAU refer to ARM documentation.

Note: It is highly recommended that systems avoid using the SAU unless necessary. Since the SAU does not affect any managers outside the Cortex®-M33, extreme care must be taken to ensure the SAU regions can not be trivially bypassed through use of another manager such as the DMA.

In addition to the Cortex®-M33 MPU provides the ability to control which regions of FLASH and RAM are marked as privileged and prevent execution of privileged code by a CPU in unprivileged state. For more information on the configuration and use of the MPU refer to ARM documentation.

10.3.9 Exception Handling

When a B MPU detects a non-secure manager attempting to access a secure address, the BMPUSECIF in SMU_IF is set and the ID of the Manager block is written to SMU_BMPUFS. If BMPUSECIEN is set and the SMU's Secure IRQ enabled, the CPU will be interrupted.

When a PPU detects an access to a secure peripheral at its non-secure address or an access to a non-secure peripheral at its secure address, PPUSECIF in SMU_IF is set and the ID of the peripheral being accessed is written to SMU_PPUFS. If PPUSECIEN is set and the SMU's Secure IRQ enabled, the CPU will be interrupted.

If a PPU detects an attempt to fetch an instruction from a peripheral, PPUINSTIF in SMU_IF will be set and the ID of the peripheral being accessed is written to SMU_PPUFS. If PPUINSTIEN is set and the SMU's Privileged IRQ enabled, the CPU will be interrupted.

If a PPU detects an attempt to access a privileged peripheral by an unprivileged manager, PPUPRIVIF in SMU_IF will be set and the ID of the peripheral being accessed is written to SMU_PPUFS. If PPUPRIVIEN is set and the SMU's Privileged IRQ enabled, the CPU will be interrupted.

When any IRQ is triggered the Cortex®-M33 is automatically placed in the privileged state. The security state is determined by configuration inside the Cortex®-M33. Refer to ARM's documentation for more details.

If the SMU is configured in an inconsistent way, the SMUPRGERR flag in SMU_STATUS will be set. One example of an invalid configuration is setting SMU_ESAUMRBR01 to a value larger than SMU_ESAUMRBR23. SMUPRGERR should be checked after the SMU is configured.

10.3.10 SMU Lock

The SMU registers can be locked to prevent unintended modifications. SMULOCK in SMU_STATUS indicates if the SMU is currently locked. To unlock the SMU write 0xACCE55 to the SMU_LOCK register. To lock write any other value to SMU_LOCK.

In addition to locking the SMU registers the SMU can prevent access to the Cortex®-M33 ASU, MPU, S MPU, V TOR and V TAIRCR registers. To lock access to one or more of these blocks set the corresponding bit in SMU_M33CTRL.

10.4 SMU Register Map

The offset register address is relative to the registers base address.

Offset	Name	Type	Description
0x000	SMU_IPVERSION	R	IP Version
0x004	SMU_STATUS	RH	Status Register
0x008	SMU_LOCK	W	Lock Register
0x00C	SMU_IF	RWH INTFLAG	Interrupt Flag Register
0x010	SMU_IEN	RW	Interrupt Enable Register
0x020	SMU_M33CTRL	RW	M33 Control Settings
0x040	SMU_PUPATD0	RW	Privileged Access
0x044	SMU_PUPATD1	RW	Privileged Access
0x060	SMU_PPUSATD0	RW	Secure Access
0x064	SMU_PPUSATD1	RW	Secure Access
0x140	SMU_PPUFS	RH	Fault Status
0x150	SMU_BMPUPATD0	RW	Privileged Attribute
0x170	SMU_BMPUSATD0	RW	Secure Attribute
0x250	SMU_BMPUFS	RH	Fault Status
0x254	SMU_BMPUFSADDR	RH	Fault Status Address
0x260	SMU_ESAURTYPES0	RW	Region Types 0
0x264	SMU_ESAURTYPES1	RW	Region Types 1
0x270	SMU_ESAUMRB01	RW	Movable Region Boundary
0x274	SMU_ESAUMRB12	RW	Movable Region Boundary
0x280	SMU_ESAUMRB45	RW	Movable Region Boundary
0x284	SMU_ESAUMRB56	RW	Movable Region Boundary
0x1000	SMU_IPVERSION_SET	R	IP Version
0x1004	SMU_STATUS_SET	RH	Status Register
0x1008	SMU_LOCK_SET	W	Lock Register
0x100C	SMU_IF_SET	RWH INTFLAG	Interrupt Flag Register
0x1010	SMU_IEN_SET	RW	Interrupt Enable Register
0x1020	SMU_M33CTRL_SET	RW	M33 Control Settings
0x1040	SMU_PUPATD0_SET	RW	Privileged Access
0x1044	SMU_PUPATD1_SET	RW	Privileged Access
0x1060	SMU_PPUSATD0_SET	RW	Secure Access
0x1064	SMU_PPUSATD1_SET	RW	Secure Access
0x1140	SMU_PPUFS_SET	RH	Fault Status
0x1150	SMU_BMPUPATD0_SET	RW	Privileged Attribute
0x1170	SMU_BMPUSATD0_SET	RW	Secure Attribute
0x1250	SMU_BMPUFS_SET	RH	Fault Status

Offset	Name	Type	Description
0x1254	SMU_BMPUFSADDR_SET	RH	Fault Status Address
0x1260	SMU_ESAURTYPES0_SET	RW	Region Types 0
0x1264	SMU_ESAURTYPES1_SET	RW	Region Types 1
0x1270	SMU_ESAUMRB01_SET	RW	Movable Region Boundary
0x1274	SMU_ESAUMRB12_SET	RW	Movable Region Boundary
0x1280	SMU_ESAUMRB45_SET	RW	Movable Region Boundary
0x1284	SMU_ESAUMRB56_SET	RW	Movable Region Boundary
0x2000	SMU_IPVERSION_CLR	R	IP Version
0x2004	SMU_STATUS_CLR	RH	Status Register
0x2008	SMU_LOCK_CLR	W	Lock Register
0x200C	SMU_IF_CLR	RWH INTFLAG	Interrupt Flag Register
0x2010	SMU_IEN_CLR	RW	Interrupt Enable Register
0x2020	SMU_M33CTRL_CLR	RW	M33 Control Settings
0x2040	SMU_PPUPATD0_CLR	RW	Privileged Access
0x2044	SMU_PPUPATD1_CLR	RW	Privileged Access
0x2060	SMU_PPUSATD0_CLR	RW	Secure Access
0x2064	SMU_PPUSATD1_CLR	RW	Secure Access
0x2140	SMU_PPUFS_CLR	RH	Fault Status
0x2150	SMU_BMPUPATD0_CLR	RW	Privileged Attribute
0x2170	SMU_BMPUSATD0_CLR	RW	Secure Attribute
0x2250	SMU_BMPUFS_CLR	RH	Fault Status
0x2254	SMU_BMPUFSADDR_CLR	RH	Fault Status Address
0x2260	SMU_ESAURTYPES0_CLR	RW	Region Types 0
0x2264	SMU_ESAURTYPES1_CLR	RW	Region Types 1
0x2270	SMU_ESAUMRB01_CLR	RW	Movable Region Boundary
0x2274	SMU_ESAUMRB12_CLR	RW	Movable Region Boundary
0x2280	SMU_ESAUMRB45_CLR	RW	Movable Region Boundary
0x2284	SMU_ESAUMRB56_CLR	RW	Movable Region Boundary
0x3000	SMU_IPVERSION_TGL	R	IP Version
0x3004	SMU_STATUS_TGL	RH	Status Register
0x3008	SMU_LOCK_TGL	W	Lock Register
0x300C	SMU_IF_TGL	RWH INTFLAG	Interrupt Flag Register
0x3010	SMU_IEN_TGL	RW	Interrupt Enable Register
0x3020	SMU_M33CTRL_TGL	RW	M33 Control Settings
0x3040	SMU_PPUPATD0_TGL	RW	Privileged Access
0x3044	SMU_PPUPATD1_TGL	RW	Privileged Access
0x3060	SMU_PPUSATD0_TGL	RW	Secure Access

Offset	Name	Type	Description
0x3064	SMU_PPUSATD1_TGL	RW	Secure Access
0x3140	SMU_PPUFS_TGL	RH	Fault Status
0x3150	SMU_BMPUPATD0_TGL	RW	Privileged Attribute
0x3170	SMU_BMPUSATD0_TGL	RW	Secure Attribute
0x3250	SMU_BMPUFS_TGL	RH	Fault Status
0x3254	SMU_BMPUFSADDR_TGL	RH	Fault Status Address
0x3260	SMU_ESAURTYPES0_TGL	RW	Region Types 0
0x3264	SMU_ESAURTYPES1_TGL	RW	Region Types 1
0x3270	SMU_ESAUMRB01_TGL	RW	Movable Region Boundary
0x3274	SMU_ESAUMRB12_TGL	RW	Movable Region Boundary
0x3280	SMU_ESAUMRB45_TGL	RW	Movable Region Boundary
0x3284	SMU_ESAUMRB56_TGL	RW	Movable Region Boundary

10.5 SMU Register Description

10.5.1 SMU_IPVERSION - IP Version

Offset	Bit Position																															
0x000	31	30	29	28	27	26	25	24	23	22	21	20	19	18	17	16	15	14	13	12	11	10	9	8	7	6	5	4	3	2	1	0
Reset																	0x3															
Access																	R															
Name																	IPVERSION															

Bit	Name	Reset	Access	Description
-----	------	-------	--------	-------------

31:0	IPVERSION	0x3	R	IP Version The read only IPVERSION field gives the version for this module. There may be minor software changes required for modules with different values of IPVERSION.
------	-----------	-----	---	--

10.5.2 SMU_STATUS - Status Register

Offset	Bit Position																															
0x004	31	30	29	28	27	26	25	24	23	22	21	20	19	18	17	16	15	14	13	12	11	10	9	8	7	6	5	4	3	2	1	0
Reset																													0x0	0x0		
Access																													R	R		
Name																													SMUPRGERR	SMULOCK		

Bit	Name	Reset	Access	Description
31:2	Reserved	To ensure compatibility with future devices, always write Reserved bits to their reset value, unless otherwise stated. More information in 1.2 Conventions		
1	SMUPRGERR	0x0	R	SMU Programming Error Indicates if SMU Registers were programmed incorrectly.
0	SMULOCK	0x0	R	SMU Lock Indicates if SMU Registers are locked.
	Value	Mode	Description	
	0	UNLOCKED		
	1	LOCKED		

10.5.3 SMU_LOCK - Lock Register

Offset	Bit Position																															
0x008	31	30	29	28	27	26	25	24	23	22	21	20	19	18	17	16	15	14	13	12	11	10	9	8	7	6	5	4	3	2	1	0
Reset																													0x0	0x0		
Access																													W	W		
Name																													SMULOCKKEY	SMULOCKKEY		

Bit	Name	Reset	Access	Description
31:24	Reserved	To ensure compatibility with future devices, always write Reserved bits to their reset value, unless otherwise stated. More information in 1.2 Conventions		
23:0	SMULOCKKEY	0x0	W	Write anything but UNLOCK to lock registers.
	Value	Mode	Description	
	11325013	UNLOCK	Unlocks Registers	

10.5.4 SMU_IF - Interrupt Flag Register

Offset	Bit Position																																
0x00C	31	30	29	28	27	26	25	24	23	22	21	20	19	18	17	16	15	14	13	12	11	10	9	8	7	6	5	4	3	2	1	0	
Reset															0x0	0x0															0x0		0x0
Access															RW	RW															RW		RW
Name															BMPUSEC	PPUSEC															PPUINST		PPUPRIV

Bit	Name	Reset	Access	Description
31:18	<i>Reserved</i>	<i>To ensure compatibility with future devices, always write Reserved bits to their reset value, unless otherwise stated. More information in 1.2 Conventions</i>		
17	BMPUSEC	0x0	RW	BMPU Security Interrupt Flag Triggered when a security fault occurs in the Bus Manager Protection Unit
16	PPUSEC	0x0	RW	PPU Security Interrupt Flag Triggered when a security fault occurs in the Peripheral Protection Unit
15:3	<i>Reserved</i>	<i>To ensure compatibility with future devices, always write Reserved bits to their reset value, unless otherwise stated. More information in 1.2 Conventions</i>		
2	PPUINST	0x0	RW	PPU Instruction Interrupt Flag Triggered when a instruction fault occurs in the Peripheral Protection Unit
1	<i>Reserved</i>	<i>To ensure compatibility with future devices, always write Reserved bits to their reset value, unless otherwise stated. More information in 1.2 Conventions</i>		
0	PPUPRIV	0x0	RW	PPU Privilege Interrupt Flag Triggered when a privilege fault occurs in the Peripheral Protection Unit

10.5.5 SMU_IEN - Interrupt Enable Register

Offset	Bit Position																																
0x010	31	30	29	28	27	26	25	24	23	22	21	20	19	18	17	16	15	14	13	12	11	10	9	8	7	6	5	4	3	2	1	0	
Reset															0x0	0x0															0x0		0x0
Access															RW	RW															RW		RW
Name															BMPUSEC	PPUSEC															PPUINST		PPUPRIV

Bit	Name	Reset	Access	Description
31:18	<i>Reserved</i>	<i>To ensure compatibility with future devices, always write Reserved bits to their reset value, unless otherwise stated. More information in 1.2 Conventions</i>		
17	BMPUSEC Set to enable the BMPUSECIF Interrupt	0x0	RW	BMPU Security Interrupt Enable
16	PPUSEC Set to enable the PPUSECIF Interrupt	0x0	RW	PPU Security Interrupt Enable
15:3	<i>Reserved</i>	<i>To ensure compatibility with future devices, always write Reserved bits to their reset value, unless otherwise stated. More information in 1.2 Conventions</i>		
2	PPUINST Set to enable the PPUINSTIF Interrupt	0x0	RW	PPU Instruction Interrupt Enable
1	<i>Reserved</i>	<i>To ensure compatibility with future devices, always write Reserved bits to their reset value, unless otherwise stated. More information in 1.2 Conventions</i>		
0	PPUPRIV Set to enable the PPUPRIVIF Interrupt	0x0	RW	PPU Privilege Interrupt Enable

10.5.6 SMU_M33CTRL - M33 Control Settings

Offset	Bit Position																															
0x020	31	30	29	28	27	26	25	24	23	22	21	20	19	18	17	16	15	14	13	12	11	10	9	8	7	6	5	4	3	2	1	0
Reset																												0x0	0x0	0x0	0x0	0x0
Access																												RW	RW	RW	RW	RW
Name																												LOCKSAU	LOCKNSMPU	LOCKSMPU	LOCKNSVTOR	LOCKSVTAIRCR

Bit	Name	Reset	Access	Description
31:5	<i>Reserved</i>	<i>To ensure compatibility with future devices, always write Reserved bits to their reset value, unless otherwise stated. More information in 1.2 Conventions</i>		
4	LOCKSAU	0x0	RW	New BitField Set to 1 lock security attribution unit
3	LOCKNSMPU	0x0	RW	New BitField Set to 1 lock non-secure MPU configuration
2	LOCKSMPU	0x0	RW	New BitField Set to 1 lock secure MPU configuration
1	LOCKNSVTOR	0x0	RW	New BitField Set to 1 lock non-secure VTOR
0	LOCKSVTAIRCR	0x0	RW	New BitField Set to 1 lock secure VTAIRCR

10.5.7 SMU_PUPATD0 - Privileged Access

Offset	Bit Position																																	
0x040	31	30	29	28	27	26	25	24	23	22	21	20	19	18	17	16	15	14	13	12	11	10	9	8	7	6	5	4	3	2	1	0		
Reset	0x1	0x1	0x1	0x1	0x1	0x1	0x1	0x1	0x1	0x1	0x1	0x1	0x1	0x1	0x1	0x1	0x1	0x1	0x1	0x1	0x1	0x1	0x1	0x1	0x1	0x1	0x1	0x1	0x1	0x1	0x1	0x1	0x1	0x1
Access	RW	RW	RW	RW	RW	RW	RW	RW	RW	RW	RW	RW	RW	RW	RW	RW	RW	RW	RW	RW	RW	RW	RW	RW	RW	RW	RW	RW	RW	RW	RW	RW	RW	RW
Name	SYSRTC	EUSART1	HOSTMAILBOX	DCDC	GPCRC	BURAM	SYSCFG	SYSCFGCFGNS	CHIPTTESTCTRL	I2C1	BURTC	USART0	TIMER4	TIMER3	TIMER2	TIMER1	TIMER0	LDMAXBAR	LDMA	GPIO	PRS	ICACHE0	MSC	ULFRCO	LFRCO	LFXO	DPLL0	FSRCO	HFRCO0	CMU	EMU			

Bit	Name	Reset	Access	Description
31	SYSRTC	0x1	RW	SYSRTC Privileged Access SYSRTC Privileged Access
30	EUSART1	0x1	RW	EUSART1 Privileged Access EUSART1 Privileged Access
29	HOSTMAILBOX	0x1	RW	HOSTMAILBOX Privileged Access HOSTMAILBOX Privileged Access
28	DCDC	0x1	RW	DCDC Privileged Access DCDC Privileged Access
27	GPCRC	0x1	RW	GPCRC Privileged Access GPCRC Privileged Access
26	BURAM	0x1	RW	BURAM Privileged Access BURAM Privileged Access
25	SYSCFG	0x1	RW	SYSCFG Privileged Access SYSCFG Privileged Access
24	SYSCFGCFGNS	0x1	RW	SYSCFGCFGNS Privileged Access SYSCFGCFGNS Privileged Access
23	CHIPTTESTCTRL	0x1	RW	CHIPTTESTCTRL Privileged Access CHIPTTESTCTRL Privileged Access
22	I2C1	0x1	RW	I2C1 Privileged Access I2C1 Privileged Access
21	BURTC	0x1	RW	BURTC Privileged Access BURTC Privileged Access
20	USART0	0x1	RW	USART0 Privileged Access USART0 Privileged Access
19	TIMER4	0x1	RW	TIMER4 Privileged Access TIMER4 Privileged Access
18	TIMER3	0x1	RW	TIMER3 Privileged Access

Bit	Name	Reset	Access	Description
	TIMER3 Privileged Access			
17	TIMER2	0x1	RW	TIMER2 Privileged Access
	TIMER2 Privileged Access			
16	TIMER1	0x1	RW	TIMER1 Privileged Access
	TIMER1 Privileged Access			
15	TIMER0	0x1	RW	TIMER0 Privileged Access
	TIMER0 Privileged Access			
14	LDMAXBAR	0x1	RW	LDMAXBAR Privileged Access
	LDMAXBAR Privileged Access			
13	LDMA	0x1	RW	LDMA Privileged Access
	LDMA Privileged Access			
12	GPIO	0x1	RW	GPIO Privileged Access
	GPIO Privileged Access			
11	PRS	0x1	RW	PRS Privileged Access
	PRS Privileged Access			
10	ICACHE0	0x1	RW	ICACHE0 Privileged Access
	ICACHE0 Privileged Access			
9	MSC	0x1	RW	MSC Privileged Access
	MSC Privileged Access			
8	ULFRCO	0x1	RW	ULFRCO Privileged Access
	ULFRCO Privileged Access			
7	LFRCO	0x1	RW	LFRCO Privileged Access
	LFRCO Privileged Access			
6	LFXO	0x1	RW	LFXO Privileged Access
	LFXO Privileged Access			
5	DPLL0	0x1	RW	DPLL0 Privileged Access
	DPLL0 Privileged Access			
4	FSRCO	0x1	RW	FSRCO Privileged Access
	FSRCO Privileged Access			
3	HFRCO0	0x1	RW	HFRCO0 Privileged Access
	HFRCO0 Privileged Access			
2	CMU	0x1	RW	CMU Privileged Access
	CMU Privileged Access			
1	EMU	0x1	RW	EMU Privileged Access
	EMU Privileged Access			
0	<i>Reserved</i>	<i>To ensure compatibility with future devices, always write Reserved bits to their reset value, unless otherwise stated. More information in 1.2 Conventions</i>		

10.5.8 SMU_PPUPATD1 - Privileged Access

Offset	Bit Position																																											
0x044	31	30	29	28	27	26	25	24	23	22	21	20	19	18	17	16	15	14	13	12	11	10	9	8	7	6	5	4	3	2	1	0												
Reset												0x1	0x1	0x1	0x1	0x1	0x1	0x1	0x1	0x1	0x1	0x1	0x1	0x1	0x1	0x1	0x1	0x1	0x1	0x1	0x1	0x1	0x1	0x1	0x1	0x1	0x1	0x1	0x1	0x1	0x1	0x1		
Access												RW	RW	RW	RW	RW	RW	RW	RW	RW	RW	RW	RW	RW	RW	RW	RW	RW	RW	RW	RW	RW	RW	RW	RW	RW	RW	RW	RW	RW	RW	RW	RW	RW
Name												AHBRADIO	MVP	SEMAILBOX	EUSART0	WDOG1	WDOG0	I2C0	HFXO0	HFRCO1	PCNT	VDAC1	VDAC0	AMUXCP0	ACMP1	ACMP0	IADC0	LETIMER0	SMUCFGNS	SMU	RADIOAES	DMEM	KEYSCAN											

Bit	Name	Reset	Access	Description
31:22	<i>Reserved</i>	<i>To ensure compatibility with future devices, always write Reserved bits to their reset value, unless otherwise stated. More information in 1.2 Conventions</i>		
21	AHBRADIO AHBRADIO Privileged Access	0x1	RW	AHBRADIO Privileged Access
20	MVP MVP Privileged Access	0x1	RW	MVP Privileged Access
19	SEMAILBOX SEMAILBOX Privileged Access	0x1	RW	SEMAILBOX Privileged Access
18	EUSART0 EUSART0 Privileged Access	0x1	RW	EUSART0 Privileged Access
17	WDOG1 WDOG1 Privileged Access	0x1	RW	WDOG1 Privileged Access
16	WDOG0 WDOG0 Privileged Access	0x1	RW	WDOG0 Privileged Access
15	I2C0 I2C0 Privileged Access	0x1	RW	I2C0 Privileged Access
14	HFXO0 HFXO0 Privileged Access	0x1	RW	HFXO0 Privileged Access
13	HFRCO1 HFRCO1 Privileged Access	0x1	RW	HFRCO1 Privileged Access
12	PCNT PCNT Privileged Access	0x1	RW	PCNT Privileged Access
11	VDAC1 VDAC1 Privileged Access	0x1	RW	VDAC1 Privileged Access
10	VDAC0 VDAC0 Privileged Access	0x1	RW	VDAC0 Privileged Access
9	AMUXCP0 AMUXCP0 Privileged Access	0x1	RW	AMUXCP0 Privileged Access

Bit	Name	Reset	Access	Description
8	ACMP1 ACMP1 Privileged Access	0x1	RW	ACMP1 Privileged Access
7	ACMP0 ACMP0 Privileged Access	0x1	RW	ACMP0 Privileged Access
6	IADC0 IADC0 Privileged Access	0x1	RW	IADC0 Privileged Access
5	LETIMER0 LETIMER0 Privileged Access	0x1	RW	LETIMER0 Privileged Access
4	SMUCFGNS SMUCFGNS Privileged Access	0x1	RW	SMUCFGNS Privileged Access
3	SMU SMU Privileged Access	0x1	RW	SMU Privileged Access
2	RADIOAES RADIOAES Privileged Access	0x1	RW	RADIOAES Privileged Access
1	DMEM DMEM Privileged Access	0x1	RW	DMEM Privileged Access
0	KEYSCAN KEYSCAN Privileged Access	0x1	RW	KEYSCAN Privileged Access

10.5.9 SMU_PPUSATD0 - Secure Access

Offset	Bit Position																																
0x060	31	30	29	28	27	26	25	24	23	22	21	20	19	18	17	16	15	14	13	12	11	10	9	8	7	6	5	4	3	2	1	0	
Reset	0x1	0x1	0x1	0x1	0x1	0x1	0x1	0x1	0x1	0x1	0x1	0x1	0x1	0x1	0x1	0x1	0x1	0x1	0x1	0x1	0x1	0x1	0x1	0x1	0x1	0x1	0x1	0x1	0x1	0x1	0x1	0x1	0x1
Access	RW	RW	RW	RW	RW	RW	RW	RW	RW	RW	RW	RW	RW	RW	RW	RW	RW	RW	RW	RW	RW	RW	RW	RW	RW	RW	RW	RW	RW	RW	RW	RW	RW
Name	SYSRTC	EUSART1	HOSTMAILBOX	DCDC	GPCRC	BURAM	SYSCFG	SYSCFGCFGNS	CHIPTTESTCTRL	I2C1	BURTC	USART0	TIMER4	TIMER3	TIMER2	TIMER1	TIMER0	LDMAXBAR	LDMA	GPIO	PRS	ICACHE0	MSC	ULFRCO	LFRCO	LFXO	DPLL0	FSRCO	HFRCO0	CMU	EMU		

Bit	Name	Reset	Access	Description
31	SYSRTC	0x1	RW	SYSRTC Secure Access SYSRTC Secure Access
30	EUSART1	0x1	RW	EUSART1 Secure Access EUSART1 Secure Access
29	HOSTMAILBOX	0x1	RW	HOSTMAILBOX Secure Access HOSTMAILBOX Secure Access
28	DCDC	0x1	RW	DCDC Secure Access DCDC Secure Access
27	GPCRC	0x1	RW	GPCRC Secure Access GPCRC Secure Access
26	BURAM	0x1	RW	BURAM Secure Access BURAM Secure Access
25	SYSCFG	0x1	RW	SYSCFG Secure Access SYSCFG Secure Access
24	SYSCFGCFGNS	0x1	RW	SYSCFGCFGNS Secure Access SYSCFGCFGNS Secure Access
23	CHIPTTESTCTRL	0x1	RW	CHIPTTESTCTRL Secure Access CHIPTTESTCTRL Secure Access
22	I2C1	0x1	RW	I2C1 Secure Access I2C1 Secure Access
21	BURTC	0x1	RW	BURTC Secure Access BURTC Secure Access
20	USART0	0x1	RW	USART0 Secure Access USART0 Secure Access
19	TIMER4	0x1	RW	TIMER4 Secure Access TIMER4 Secure Access
18	TIMER3	0x1	RW	TIMER3 Secure Access

Bit	Name	Reset	Access	Description
	TIMER3 Secure Access			
17	TIMER2	0x1	RW	TIMER2 Secure Access
	TIMER2 Secure Access			
16	TIMER1	0x1	RW	TIMER1 Secure Access
	TIMER1 Secure Access			
15	TIMER0	0x1	RW	TIMER0 Secure Access
	TIMER0 Secure Access			
14	LDMAXBAR	0x1	RW	LDMAXBAR Secure Access
	LDMAXBAR Secure Access			
13	LDMA	0x1	RW	LDMA Secure Access
	LDMA Secure Access			
12	GPIO	0x1	RW	GPIO Secure Access
	GPIO Secure Access			
11	PRS	0x1	RW	PRS Secure Access
	PRS Secure Access			
10	ICACHE0	0x1	RW	ICACHE0 Secure Access
	ICACHE0 Secure Access			
9	MSC	0x1	RW	MSC Secure Access
	MSC Secure Access			
8	ULFRCO	0x1	RW	ULFRCO Secure Access
	ULFRCO Secure Access			
7	LFRCO	0x1	RW	LFRCO Secure Access
	LFRCO Secure Access			
6	LFXO	0x1	RW	LFXO Secure Access
	LFXO Secure Access			
5	DPLL0	0x1	RW	DPLL0 Secure Access
	DPLL0 Secure Access			
4	FSRCO	0x1	RW	FSRCO Secure Access
	FSRCO Secure Access			
3	HFRCO0	0x1	RW	HFRCO0 Secure Access
	HFRCO0 Secure Access			
2	CMU	0x1	RW	CMU Secure Access
	CMU Secure Access			
1	EMU	0x1	RW	EMU Secure Access
	EMU Secure Access			
0	<i>Reserved</i>	<i>To ensure compatibility with future devices, always write Reserved bits to their reset value, unless otherwise stated. More information in 1.2 Conventions</i>		

10.5.10 SMU_PPUSATD1 - Secure Access

Offset	Bit Position																																											
0x064	31	30	29	28	27	26	25	24	23	22	21	20	19	18	17	16	15	14	13	12	11	10	9	8	7	6	5	4	3	2	1	0												
Reset												0x1	0x1	0x1	0x1	0x1	0x1	0x1	0x1	0x1	0x1	0x1	0x1	0x1	0x1	0x1	0x1	0x1	0x1	0x1	0x1	0x1	0x1	0x1	0x1	0x1	0x1	0x1	0x1	0x1	0x1	0x1		
Access												RW	RW	RW	RW	RW	RW	RW	RW	RW	RW	RW	RW	RW	RW	RW	RW	RW	RW	RW	RW	RW	RW	RW	RW	RW	RW	RW	RW	RW	RW	RW	RW	RW
Name												AHBRADIO	MVP	SEMAILBOX	EUSART0	WDOG1	WDOG0	I2C0	HFXO0	HFRCO1	PCNT	VDAC1	VDAC0	AMUXCP0	ACMP1	ACMP0	IADC0	LETIMER0	SMUCFGNS	SMU	RADIOAES	DMEM	KEYSCAN											

Bit	Name	Reset	Access	Description
31:22	<i>Reserved</i>	<i>To ensure compatibility with future devices, always write Reserved bits to their reset value, unless otherwise stated. More information in 1.2 Conventions</i>		
21	AHBRADIO AHBRADIO Secure Access	0x1	RW	AHBRADIO Secure Access
20	MVP MVP Secure Access	0x1	RW	MVP Secure Access
19	SEMAILBOX SEMAILBOX Secure Access	0x1	RW	SEMAILBOX Secure Access
18	EUSART0 EUSART0 Secure Access	0x1	RW	EUSART0 Secure Access
17	WDOG1 WDOG1 Secure Access	0x1	RW	WDOG1 Secure Access
16	WDOG0 WDOG0 Secure Access	0x1	RW	WDOG0 Secure Access
15	I2C0 I2C0 Secure Access	0x1	RW	I2C0 Secure Access
14	HFXO0 HFXO0 Secure Access	0x1	RW	HFXO0 Secure Access
13	HFRCO1 HFRCO1 Secure Access	0x1	RW	HFRCO1 Secure Access
12	PCNT PCNT Secure Access	0x1	RW	PCNT Secure Access
11	VDAC1 VDAC1 Secure Access	0x1	RW	VDAC1 Secure Access
10	VDAC0 VDAC0 Secure Access	0x1	RW	VDAC0 Secure Access
9	AMUXCP0 AMUXCP0 Secure Access	0x1	RW	AMUXCP0 Secure Access

Bit	Name	Reset	Access	Description
8	ACMP1 ACMP1 Secure Access	0x1	RW	ACMP1 Secure Access
7	ACMP0 ACMP0 Secure Access	0x1	RW	ACMP0 Secure Access
6	IADC0 IADC0 Secure Access	0x1	RW	IADC0 Secure Access
5	LETIMER0 LETIMER0 Secure Access	0x1	RW	LETIMER0 Secure Access
4	SMUCFGNS SMUCFGNS Secure Access	0x1	RW	SMUCFGNS Secure Access
3	SMU SMU Secure Access	0x1	RW	SMU Secure Access
2	RADIOAES RADIOAES Secure Access	0x1	RW	RADIOAES Secure Access
1	DMEM DMEM Secure Access	0x1	RW	DMEM Secure Access
0	KEYSCAN KEYSCAN Secure Access	0x1	RW	KEYSCAN Secure Access

10.5.11 SMU_PPUFS - Fault Status

Offset	Bit Position																															
0x140	31	30	29	28	27	26	25	24	23	22	21	20	19	18	17	16	15	14	13	12	11	10	9	8	7	6	5	4	3	2	1	0
Reset																									0x0							
Access																									R							
Name																									PPUFSPERIPHID							

Bit	Name	Reset	Access	Description
31:8	<i>Reserved</i>	<i>To ensure compatibility with future devices, always write Reserved bits to their reset value, unless otherwise stated. More information in 1.2 Conventions</i>		
7:0	PPUFSPERIPHID ID of the peripheral that caused the fault.	0x0	R	Peripheral ID

10.5.12 SMU_BMPUPATD0 - Privileged Attribute

Offset	Bit Position																																																						
0x150	31	30	29	28	27	26	25	24	23	22	21	20	19	18	17	16	15	14	13	12	11	10	9	8	7	6	5	4	3	2	1	0																							
Reset																								0x0	0x0	0x0	0x1	0x1	0x1	0x1	0x1	0x1	0x1	0x1	0x1	0x1	0x1	0x1	0x1	0x1	0x1	0x1	0x1	0x1	0x1	0x1	0x1	0x1	0x1	0x1	0x1	0x1	0x1	0x1	
Access																								RW	RW	RW	RW	RW	RW	RW	RW	RW	RW	RW	RW	RW	RW	RW	RW	RW	RW	RW	RW	RW	RW	RW	RW	RW	RW	RW	RW	RW	RW	RW	RW
Name																								SEEXTDMA	RFECA1	RFECA0	MVPAHBDATA2	MVPAHBDATA1	MVPAHBDATA0	LDMA	RADIOSUBSYSTEM	RADIOAES																							

Bit	Name	Reset	Access	Description
31:9	<i>Reserved</i>	<i>To ensure compatibility with future devices, always write Reserved bits to their reset value, unless otherwise stated. More information in 1.2 Conventions</i>		
8	SEEXTDMA SEEXTDMA privileged mode	0x0	RW	SEEXTDMA privileged mode
7	RFECA1 RFECA1 privileged mode	0x0	RW	RFECA1 privileged mode
6	RFECA0 RFECA0 privileged mode	0x0	RW	RFECA0 privileged mode
5	MVPAHBDATA2 MVPAHBDATA2 privileged mode	0x1	RW	MVPAHBDATA2 privileged mode
4	MVPAHBDATA1 MVPAHBDATA1 privileged mode	0x1	RW	MVPAHBDATA1 privileged mode
3	MVPAHBDATA0 MVPAHBDATA0 privileged mode	0x1	RW	MVPAHBDATA0 privileged mode
2	LDMA MCU LDMA privileged mode	0x1	RW	MCU LDMA privileged mode
1	RADIOSUBSYSTEM RADIO subsystem manager privileged mode	0x1	RW	RADIO subsystem manager privileged mode
0	RADIOAES RADIO AES DMA privileged mode	0x1	RW	RADIO AES DMA privileged mode

10.5.13 SMU_BMPUSATD0 - Secure Attribute

Offset	Bit Position																																																						
0x170	31	30	29	28	27	26	25	24	23	22	21	20	19	18	17	16	15	14	13	12	11	10	9	8	7	6	5	4	3	2	1	0																							
Reset																								0x0	0x0	0x0	0x1	0x1	0x1	0x1	0x1	0x1	0x1	0x1	0x1	0x1	0x1	0x1	0x1	0x1	0x1	0x1	0x1	0x1	0x1	0x1	0x1	0x1	0x1	0x1	0x1	0x1	0x1	0x1	
Access																								RW	RW	RW	RW	RW	RW	RW	RW	RW	RW	RW	RW	RW	RW	RW	RW	RW	RW	RW	RW	RW	RW	RW	RW	RW	RW	RW	RW	RW	RW	RW	RW
Name																								SEEXTDMA	RFECA1	RFECA0	MVPAHBDATA2	MVPAHBDATA1	MVPAHBDATA0	LDMA	RADIOSUBSYSTEM	RADIOAES																							

Bit	Name	Reset	Access	Description
31:9	<i>Reserved</i>	<i>To ensure compatibility with future devices, always write Reserved bits to their reset value, unless otherwise stated. More information in 1.2 Conventions</i>		
8	SEEXTDMA SEEXTDMA secure mode	0x0	RW	SEEXTDMA secure mode
7	RFECA1 RFECA1 secure mode	0x0	RW	RFECA1 secure mode
6	RFECA0 RFECA0 secure mode	0x0	RW	RFECA0 secure mode
5	MVPAHBDATA2 MVPAHBDATA2 secure mode	0x1	RW	MVPAHBDATA2 secure mode
4	MVPAHBDATA1 MVPAHBDATA1 secure mode	0x1	RW	MVPAHBDATA1 secure mode
3	MVPAHBDATA0 MVPAHBDATA0 secure mode	0x1	RW	MVPAHBDATA0 secure mode
2	LDMA MCU LDMA secure mode	0x1	RW	MCU LDMA secure mode
1	RADIOSUBSYSTEM RADIO subsystem manager secure mode	0x1	RW	RADIO subsystem manager secure mode
0	RADIOAES RADIOAES DMA secure mode	0x1	RW	RADIOAES DMA secure mode

10.5.14 SMU_BMPUFS - Fault Status

Offset	Bit Position																															
0x250	31	30	29	28	27	26	25	24	23	22	21	20	19	18	17	16	15	14	13	12	11	10	9	8	7	6	5	4	3	2	1	0
Reset																									0x0							
Access																									R							
Name																									BMPUFSMASTERID							

Bit	Name	Reset	Access	Description
31:8	<i>Reserved</i>	<i>To ensure compatibility with future devices, always write Reserved bits to their reset value, unless otherwise stated. More information in 1.2 Conventions</i>		
7:0	BMPUFSMASTERID	0x0	R	Bus Manager ID ID of Bus Manager that triggered fault

10.5.15 SMU_BMPUFSADDR - Fault Status Address

Offset	Bit Position																															
0x254	31	30	29	28	27	26	25	24	23	22	21	20	19	18	17	16	15	14	13	12	11	10	9	8	7	6	5	4	3	2	1	0
Reset																									0x0							
Access																									R							
Name																									BMPUFSADDR							

Bit	Name	Reset	Access	Description
31:0	BMPUFSADDR	0x0	R	Fault Address Access address that triggered fault

10.5.16 SMU_ESAURTYPES0 - Region Types 0

Offset	Bit Position																															
0x260	31	30	29	28	27	26	25	24	23	22	21	20	19	18	17	16	15	14	13	12	11	10	9	8	7	6	5	4	3	2	1	0
Reset																					0x0											
Access																					RW											
Name																					ESAUR3NS											

Bit	Name	Reset	Access	Description
31:13	Reserved	To ensure compatibility with future devices, always write Reserved bits to their reset value, unless otherwise stated. More information in 1.2 Conventions		
12	ESAUR3NS	0x0	RW	Region 3 Non-Secure Set to 1 to configure Region 3 as Non-secure
11:0	Reserved	To ensure compatibility with future devices, always write Reserved bits to their reset value, unless otherwise stated. More information in 1.2 Conventions		

10.5.17 SMU_ESAURTYPES1 - Region Types 1

Offset	Bit Position																															
0x264	31	30	29	28	27	26	25	24	23	22	21	20	19	18	17	16	15	14	13	12	11	10	9	8	7	6	5	4	3	2	1	0
Reset																					0x0											
Access																					RW											
Name																					ESAUR11NS											

Bit	Name	Reset	Access	Description
31:13	Reserved	To ensure compatibility with future devices, always write Reserved bits to their reset value, unless otherwise stated. More information in 1.2 Conventions		
12	ESAUR11NS	0x0	RW	Region 11 Non-Secure Set to 1 to configure Region 11 as Non-secure
11:0	Reserved	To ensure compatibility with future devices, always write Reserved bits to their reset value, unless otherwise stated. More information in 1.2 Conventions		

10.5.18 SMU_ESAUMRB01 - Movable Region Boundary

Offset	Bit Position																																
0x270	31	30	29	28	27	26	25	24	23	22	21	20	19	18	17	16	15	14	13	12	11	10	9	8	7	6	5	4	3	2	1	0	
Reset																	0xA000																
Access																	RW																
Name																	ESAUMRB01																

Bit	Name	Reset	Access	Description
31:28	Reserved	To ensure compatibility with future devices, always write Reserved bits to their reset value, unless otherwise stated. More information in 1.2 Conventions		
27:12	ESAUMRB01	0xA000	RW	Moveable Region Boundary Moveable Region Boundary between Region 0 and Region 1. Address Represents the start of Region 1 at a 4kB offset.
11:0	Reserved	To ensure compatibility with future devices, always write Reserved bits to their reset value, unless otherwise stated. More information in 1.2 Conventions		

10.5.19 SMU_ESAUMRB12 - Movable Region Boundary

Offset	Bit Position																																
0x274	31	30	29	28	27	26	25	24	23	22	21	20	19	18	17	16	15	14	13	12	11	10	9	8	7	6	5	4	3	2	1	0	
Reset																	0xC000																
Access																	RW																
Name																	ESAUMRB12																

Bit	Name	Reset	Access	Description
31:28	Reserved	To ensure compatibility with future devices, always write Reserved bits to their reset value, unless otherwise stated. More information in 1.2 Conventions		
27:12	ESAUMRB12	0xC000	RW	Moveable Region Boundary Moveable Region Boundary between Region 1 and Region 2. Address Represents the start of Region 2 at a 4kB offset.
11:0	Reserved	To ensure compatibility with future devices, always write Reserved bits to their reset value, unless otherwise stated. More information in 1.2 Conventions		

10.5.20 SMU_ESAUMRB45 - Movable Region Boundary

Offset	Bit Position																															
0x280	31	30	29	28	27	26	25	24	23	22	21	20	19	18	17	16	15	14	13	12	11	10	9	8	7	6	5	4	3	2	1	0
Reset												0x2000																				
Access												RW																				
Name												ESAUMRB45																				

Bit	Name	Reset	Access	Description
31:28	Reserved	To ensure compatibility with future devices, always write Reserved bits to their reset value, unless otherwise stated. More information in 1.2 Conventions		
27:12	ESAUMRB45	0x2000	RW	Moveable Region Boundary Moveable Region Boundary between Regions 4 and 5. This represents the starting address of Region 5.
11:0	Reserved	To ensure compatibility with future devices, always write Reserved bits to their reset value, unless otherwise stated. More information in 1.2 Conventions		

10.5.21 SMU_ESAUMRB56 - Movable Region Boundary

Offset	Bit Position																															
0x284	31	30	29	28	27	26	25	24	23	22	21	20	19	18	17	16	15	14	13	12	11	10	9	8	7	6	5	4	3	2	1	0
Reset												0x4000																				
Access												RW																				
Name												ESAUMRB56																				

Bit	Name	Reset	Access	Description
31:28	Reserved	To ensure compatibility with future devices, always write Reserved bits to their reset value, unless otherwise stated. More information in 1.2 Conventions		
27:12	ESAUMRB56	0x4000	RW	Moveable Region Boundary Moveable Region Boundary between Regions 5 and 6. This represents the starting address of Region 6.
11:0	Reserved	To ensure compatibility with future devices, always write Reserved bits to their reset value, unless otherwise stated. More information in 1.2 Conventions		

11. SE - Secure Engine Subsystem

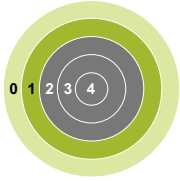

Quick Facts

What?

The Secure Engine Subsystem encapsulates security peripherals providing both improved system security and ease of use.

Why?

Isolation of security hardware from the Cortex®-M33 protects the SE system from exploits that target the main CPU. The subsystem also provides autonomous cryptographic operations allowing the main CPU to perform other tasks or enter EM1 to save power.

How?

Security peripherals are completely isolated from the main CPU and controlled with a processor internal to the SE subsystem.

11.1 Introduction

The Secure Engine (SE) provides several security features and acts as a barrier protecting the security hardware from activity on the Cortex®-M33. It also enables autonomous operation of security features.

Available features include:

- Secure Boot with Root of Trust and Secure Loader (RTSL)
- Hardware Cryptographic Acceleration with DPA countermeasures for AES128/256, SHA-1, SHA-2 (up to 256-bit), ECC (up to 256-bit), ECDSA, ECDH and J-Pake
- True Random Number Generator (TRNG) compliant with NIST SP800-90 and AIS-31
- ARM® TrustZone®
- Secure Debug with lock/unlock

All Secure Engine functions are enabled by software. These functions are fully described in the Secure Engine emlib online documentation located at the following link:

<https://docs.silabs.com/mcu/latest/efr32mg21/group-SE>

11.2 Security Features

11.2.1 Security Features Overview

- Acceleration of cryptographic functions
 - AES encryption and decryption with 128, 192, or 256-bit keys
 - Supported block cipher modes of operation for AES include: ECB, CTR, CBC, CFB, CBC-MAC, CMAC, CCM, GCM and GMAC.
 - ECC over GF(P) up to 256-bit
 - Supported ECC NIST recommended curves include P-192 and P-256
 - SHA-1 and SHA-2 up to 256-bit
- True Random Number Generation
 - Entropy Source complies to NIST 800-90B requirements
 - Online Health tests comply to NIST 800-90 and AIS31 requirements
 - Random Data Passes NIST 800-22 and NIST 800-90B test suites
- Secure Boot Loader (First Stage Boot Loader)

11.2.2 Secure Boot with Root of Trust and Secure Loader (RTSL)

The Secure Boot with RTSL authenticates a chain of trusted firmware that begins from an immutable memory (ROM).

It prevents malware injection, prevents rollback, ensures that only authentic firmware is executed, and protects Over The Air updates.

For more information about this feature, see [AN1218: Series 2 Secure Boot with RTSL](#).

11.2.3 Secure Debug

The SE provides a secure debug unlock function that allows users to grant debug access to locked devices on a device by device basis. To use this function the device must be programmed with a public Command key by the user. To unlock a device, a unique challenge (a device-unique persistent random set of bytes) must be read out and signed by the private key associated with public Command key creating an unlock token. The device can then be unlocked by providing the valid unlock token. The token can be used to unlock the device any number of times. There is also a command to force the device to update its challenge, which revokes the previously-generated token.

More information on Secure Debug can be found in the AN1190: Secure Debug application note.

Note: Secure debug locking a device will limit the capability for Silicon Labs to perform failure analysis on the device. Provide secure debug tokens for each device when submitting parts for failure analysis.

11.2.4 Cryptographic Accelerator

The Cryptographic Accelerator is an autonomous hardware accelerator with Differential Power Analysis (DPA) countermeasures to protect keys.

It supports AES encryption and decryption with 128/192/256-bit keys, ChaCha20 encryption, and Elliptic Curve Cryptography (ECC) to support public key operations, and hashes.

Supported block cipher modes of operation for AES include:

- ECB (Electronic Code Book)
- CTR (Counter Mode)
- CBC (Cipher Block Chaining)
- CFB (Cipher Feedback)
- GCM (Galois Counter Mode)
- CCM (Counter with CBC-MAC)
- CBC-MAC (Cipher Block Chaining Message Authentication Code)
- GMAC (Galois Message Authentication Code)

The Cryptographic Accelerator accelerates Elliptical Curve Cryptography and supports the NIST (National Institute of Standards and Technology) recommended curves including P-192, P-256, P-384, and P-521 for ECDH (Elliptic Curve Diffie-Hellman) key derivation, and ECDSA (Elliptic Curve Digital Signature Algorithm) sign and verify operations. Also supported is the non-NIST Curve25519 for ECDH and Ed25519 for EdDSA (Edwards-curve Digital Signature Algorithm) sign and verify operations.

Secure Vault also supports ECJ-PAKE (Elliptic Curve variant of Password Authenticated Key Exchange by Juggling) and PBKDF2 (Password-Based Key Derivation Function 2).

Supported hashes include SHA-1, SHA-2/256/384/512 and Poly1305.

This implementation provides a fast and energy efficient solution to state of the art cryptographic needs.

11.2.5 True Random Number Generation

The SE provides access to a non-deterministic random number generator based on a full hardware solution. The TRNG output passes the NIST 800-22 and AIS31 test suites. The TRNG module includes several built-in self tests to detect issues with the noise source, ensure entropy, and meet cryptography standards. The Repetition Count Test and Adaptive Proportion Test with window sizes of 64 and 4096 bits described in section 6.5.1.2 of NIST-800-90B are implemented in hardware and run continuously on the data.

<http://csrc.nist.gov/publications/drafts/800-90/draft-sp800-90b.pdf>

The AIS31 Online Test described in section 5.5.3 of AIS 31 is also implemented in hardware, and runs continuously on the data.

https://www.bsi.bund.de/SharedDocs/Downloads/DE/BSI/Zertifizierung/Interpretationen/AIS_31_Functionality_classes_for_random_number_generators_e.pdf

11.3 SE Mailbox

All communication with the Secure Engine Subsystem takes place through the SE Mailbox. Operations are performed by using the mailbox to sending a command and then receive the SE response. The mailbox is a bidirectional 64 word FIFO.

11.3.1 Sending Commands

The TX FIFO has two status flags in SE_TX_STATUS register. TXFULL is set when the FIFO is full and TXINT is set if there is space in the FIFO for at least 16 words. If TXINTEN in SE_CONFIGURATION is set an interrupt will be generated when TXINT is set.

Writing to any SE_DATAn register will result in data being placed in the FIFO. For example, to write 16 words to the FIFO software may write SE_DATA0 16 times, or may make a single write to each of the 16 SE_DATAn registers. If the FIFO is written when no space is available, the CPU will be stalled until spaces becomes available and the write can be completed.

To send a command, first check TXINT to ensure that there is space available in the FIFO. Then write SE_TX_HEADER with the command length and protection bit. Finally, write the command data into the SE_DATAn registers. While the command is being written, BYTERM in SE_TX_STATUS will contain the number of bytes remaining in the command. To ensure minimal performance impact, software should ensure that space exists in the FIFO before writing to it.

11.3.2 Receiving Responses

The RX FIFO has two status flags in SE_RX_STATUS register. RXEMPTY is set when the FIFO is empty and RXINT is set if there are at least 4 words in the FIFO or if the final word of the message is present in the FIFO. If RXINTEN in SE_CONFIGURATION is set, an interrupt will be generated when RXINT is set.

Reading from any SE_DATAn register will result in data being read from the FIFO. For example, to read 16 words from the FIFO, software may read SE_DATA0 16 times, or may make a single read from each of the 16 SE_DATAn registers. If the FIFO is read when it is empty and no message is available, a 0x0 will be read. If the FIFO is read when empty and a message is being processed, the CPU will be stalled until data becomes available.

Software may check for responses by polling RXINT, RXEMPTY, or RXHEADER in SE_RX_STATUS. The RXINT interrupt may also be used to notify the CPU when data is available. To receive a response first read the response header from SE_RX_HEADER. Software may read the message size from SE_RX_HEADER, or use BYTERM in SE_RX_STATUS, which contains the number of words remaining in the response.

The command status is available in both SE_RX_STATUS and SE_RX_HEADER and indicates if the command completed successfully.

11.3.3 MAILBOX Register Map

The offset register address is relative to the registers base address.

Offset	Name	Type	Description
0x000	MAILBOX_MSGPTRx	RW	Message Pointer
0x040	MAILBOX_IF	RW INTFLAG	Interrupt Flag Register
0x044	MAILBOX_IEN	RW	Interrupt Enable Register
0x1000	MAILBOX_MSGPTRx_SET	RW	Message Pointer
0x1040	MAILBOX_IF_SET	RW INTFLAG	Interrupt Flag Register
0x1044	MAILBOX_IEN_SET	RW	Interrupt Enable Register
0x2000	MAILBOX_MSGPTRx_CLR	RW	Message Pointer
0x2040	MAILBOX_IF_CLR	RW INTFLAG	Interrupt Flag Register
0x2044	MAILBOX_IEN_CLR	RW	Interrupt Enable Register
0x3000	MAILBOX_MSGPTRx_TGL	RW	Message Pointer
0x3040	MAILBOX_IF_TGL	RW INTFLAG	Interrupt Flag Register
0x3044	MAILBOX_IEN_TGL	RW	Interrupt Enable Register

11.3.4 MAILBOX Register Description

11.3.4.1 MAILBOX_MSGPTRx - Message Pointer

Offset	Bit Position																															
0x000	31	30	29	28	27	26	25	24	23	22	21	20	19	18	17	16	15	14	13	12	11	10	9	8	7	6	5	4	3	2	1	0
Reset	0x0																															
Access	RW																															
Name	PTR																															

Bit	Name	Reset	Access	Description
31:0	PTR	0x0	RW	Pointer The Memory Address of the message.

11.3.4.2 MAILBOX_IF - Interrupt Flag Register

Offset	Bit Position																															
0x040	31	30	29	28	27	26	25	24	23	22	21	20	19	18	17	16	15	14	13	12	11	10	9	8	7	6	5	4	3	2	1	0
Reset	0x0																															
Access	RW																															
Name	MBOXIF3 MBOXIF2 MBOXIF1 MBOXIF0																															

Bit	Name	Reset	Access	Description
31:4	<i>Reserved</i>	<i>To ensure compatibility with future devices, always write Reserved bits to their reset value, unless otherwise stated. More information in 1.2 Conventions</i>		
3	MBOXIF3	0x0	RW	Mailbox Interupt Flag When set, Mailbox Message Availble.
2	MBOXIF2	0x0	RW	Mailbox Interupt Flag When set, Mailbox Message Availble.
1	MBOXIF1	0x0	RW	Mailbox Interupt Flag When set, Mailbox Message Availble.
0	MBOXIF0	0x0	RW	Mailbox Interupt Flag When set, Mailbox Message Availble.

11.3.4.3 MAILBOX_IEN - Interrupt Enable Register

Offset	Bit Position																															
0x044	31	30	29	28	27	26	25	24	23	22	21	20	19	18	17	16	15	14	13	12	11	10	9	8	7	6	5	4	3	2	1	0
Reset																											0x0	0x0	0x0	0x0		
Access																											RW	RW	RW	RW		
Name																											MBOXIEN3	MBOXIEN2	MBOXIEN1	MBOXIEN0		

Bit	Name	Reset	Access	Description
31:4	<i>Reserved</i>	<i>To ensure compatibility with future devices, always write Reserved bits to their reset value, unless otherwise stated. More information in 1.2 Conventions</i>		
3	MBOXIEN3 Set to enable the MBOXIF Interrupt	0x0	RW	Mailbox Interrupt Enable
2	MBOXIEN2 Set to enable the MBOXIF Interrupt	0x0	RW	Mailbox Interrupt Enable
1	MBOXIEN1 Set to enable the MBOXIF Interrupt	0x0	RW	Mailbox Interrupt Enable
0	MBOXIEN0 Set to enable the MBOXIF Interrupt	0x0	RW	Mailbox Interrupt Enable

12. EMU - Energy Management Unit

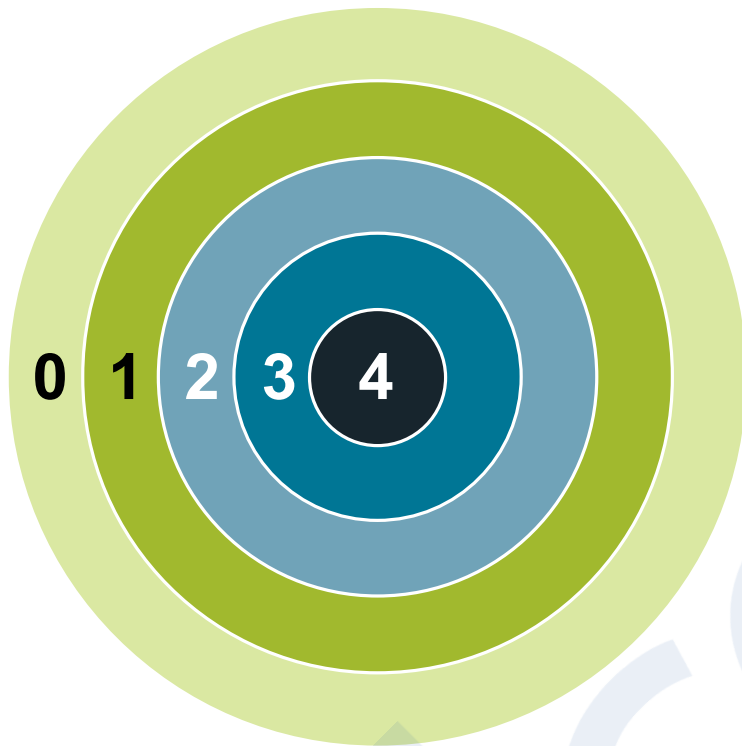

12.1 Introduction

The Energy Management Unit (EMU) manages all the low energy modes (EM) in EFR32xG24. Each energy mode manages whether the CPU and the various peripherals are available. The energy modes range from EM0 to EM4. EM0 mode provides the highest amount of features, enabling the CPU, Radio, and peripherals with the highest clock frequency. EM4 Mode provides the lowest power state, allowing the part to return to EM0 on a wake-up condition. The EMU also controls the internal regulators settings and voltage monitoring needed for optimal power configuration and protection.

Quick Facts

What?

The EMU (Energy Management Unit) handles the different low energy modes in EFR32xG24

Why?

The need for performance and peripheral functions varies over time in most applications. By efficiently scaling the available resources in real time to match the demands of the application, the energy consumption can be kept at a minimum.

How?

With a broad selection of energy modes, a high number of low-energy peripherals available even in EM2, and short wake-up time, applications can dynamically minimize energy consumption during program execution.

12.2 Features

The primary features of the EMU are listed below:

- Energy Modes control
 - Entry into EM4
 - Configuration of regulators and clocks for each Energy Mode
 - Configuration of various EM4 wake-up conditions
 - Configuration of GPIO retention settings
- Power routing configurations
 - DCDC control and bypass
- Temperature sensor
- Brown Out Detection
- Supply voltage scaling
 - EM0 / EM1 voltage scaling
 - EM2 / EM3 voltage scaling
- Reset Management
 - Power-on Reset (POR)
 - Brown-out Detection (BOD) on the following power domains:
 - Analog Unregulated Power Domain AVDD
 - Digital Unregulated Power Domain DVDD
 - I/O Unregulated Power Domain IOVDDx
 - Regulated Digital Domain DECOUPLE (DEC)
 - RESETn pin reset
 - Watchdog (WDOG) reset
 - Software triggered reset (SYSRESETREQ)
 - Core LOCKUP condition
 - EM4 Detection
 - EM4 wakeup reset from GPIO pin
 - Configurable reset levels
 - A software readable register indicates the cause of the last reset

12.3 Functional Description

The EMU is responsible for managing the wide range of energy modes available in EFR32xG24. The block works in harmony with the entire platform to easily transition between energy modes in the most efficient manner possible. The following diagram [Figure 12.1 EMU Overview](#) on [page 290](#), shows the relative connectivity to the various blocks in the system.

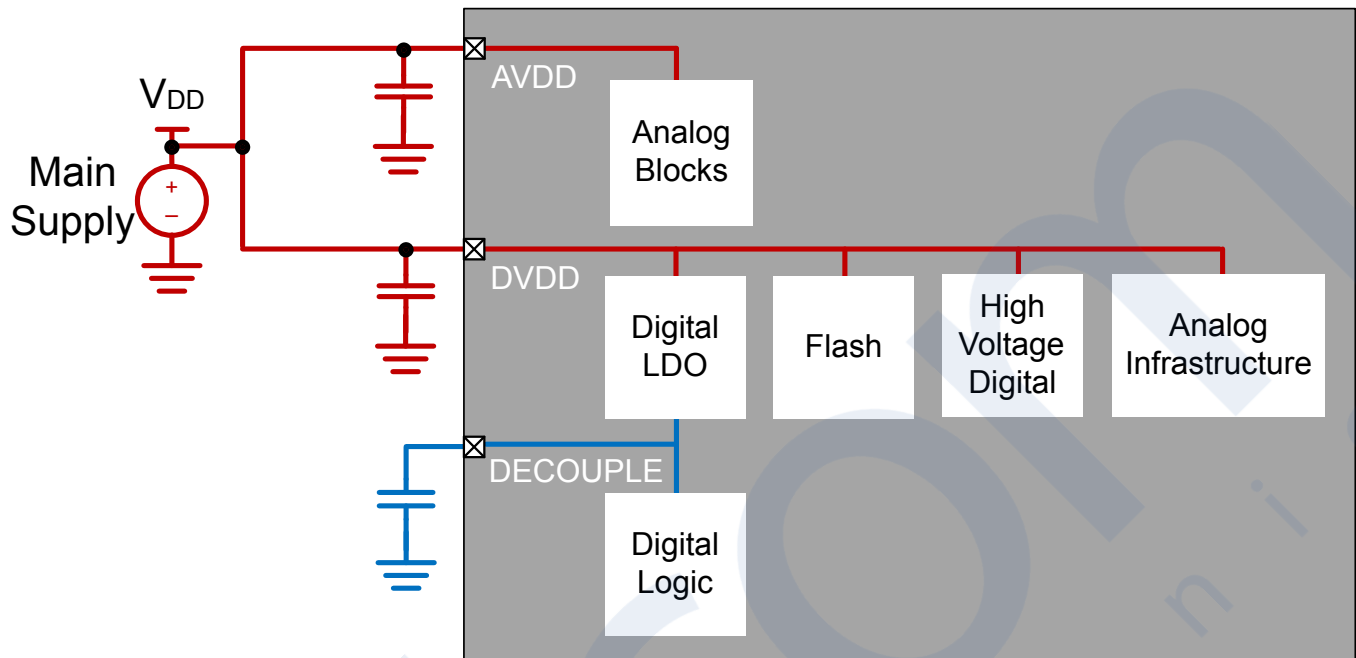

Figure 12.1. EMU Overview

The EMU is available on the peripheral bus. The energy management state machine controls the internal voltage regulators, oscillators, memories, and interrupt system. Events, interrupts, and resets can trigger the energy management state machine to return to the active state. This is further described in the following sections.

12.3.1 Energy Modes

EFR32xG24 features five main energy modes, referred to as Energy Mode 0 (EM0) through Energy Mode 4 (EM4). The Cortex®-M33 is only available for program execution in EM0. In EM0 Active/EM1 Sleep any peripheral function can be enabled. EM2 through EM4, also referred to as low energy modes, provide a significantly reduced energy consumption while still allowing a rich set of peripheral functionality. The following [Table 12.1 table on page 291](#) shows the possible transitions between different energy modes.

Table 12.1. Energy Mode Transitions

Current Mode	EM Transition Action				
	Enter EM0	Enter EM1	Enter EM2	Enter EM3	Enter EM4
EM0		Sleep (WFI, WFE)	Deep Sleep (WFI, WFE)	Deep Sleep (WFI, WFE)	EM4 Entry
EM1	IRQ		Peripheral wake up done ¹	Peripheral wake up done ¹	
EM2	IRQ	Peripheral wake up req ¹			
EM3	IRQ	Peripheral wake up req ¹			
EM4	Wake Up				

Note:
1. Peripheral wake-up from EM2/3 to EM1 and then automatically back to EM2/3 when done.

Certain peripherals and timers in the radio subsystem have the ability to temporarily turn on additional logic in EM2 or EM3 to receive and transmit data or trigger LDMA transfers without intervention from the M33 core. The system automatically returns to the original energy mode when such operations are complete.

The Core can always request to go to EM1 with the WFI or WFE command during EM0. The core will be prevented from entering EM2 or EM3 if the radio is transferring data or if flash is programming or erasing.

An overview of supported energy modes and available functionality is shown in the following table. For each energy mode, the system will typically default to its lowest power configuration, with non-essential clocks and peripherals disabled. Functionality may be then selectively enabled by software.

Modules with EM2/3/4 capability exist in a Low Power Domain (e.g., PD0x or PDHV). Refer to [12.3.4 Power Domains](#) for more details.

Table 12.2. Energy Modes

	EM0 / EM1	EM2 / EM3	EM4	Low Power Domain
Cortex®-M33 Core Active	EM0 only	-	-	-
Debug	Available	Available ¹	-	PD0D
Digital logic and system RAM retained	Yes	Yes	-	-
Flash Memory Access	Available	-	-	-
LDMA (Linked DMA Controller)	Available	Available ²	-	-
Radio Controller (RAC)	Available	Available ³	-	-
High Frequency Clocks (BUSCLK, HCLK, PCLK, RADIOCLK, EM01GRPACLK, EM01GRPCCLK)	Available	-	-	-

	EM0 / EM1	EM2 / EM3	EM4	Low Power Domain
High Frequency Oscillator (HF XO)	Available	-	-	PD0C
High Frequency RC Oscillator (HFRCODPLL)	Available	-	-	-
ADC Clock (IADCCLK), VDAC0 Clock (VDAC0CLK), and VDAC1 Clock (VDAC1CLK)	Available	Available ⁴	-	-
EM2/3 High Frequency RC Oscillator (HFRCOEM23)	Available	Available ⁴	-	PD0C
Fast Start-up RC Oscillator (FSRCO)	Available	Available ⁴	-	PD0A
Low Frequency RC Oscillators (LFRCO)	Available	EM2 Only	Available ⁵	PDHV (normal mode) or PD0C (precision mode)
Low Frequency Crystal Oscillator (LFXO)	Available	EM2 Only	Available ⁵	PDHV
Low Energy Clocks (EM23GRPACLK, WDOGnCLK, SYSRTCCLK, PCNT0CLK, EUSART0CLK)	Available	Available ⁶	-	-
EM4 Clock (EM4GRPACLK)	Available	Available ⁶	Available ⁵	-
ULFRCO (Ultra Low Frequency Oscillator)	On	On	Available ⁵	PDHV
GPCRC (General Purpose Cyclic Redundancy Check)	Available	-	-	-
BURTC	Available	Available ⁶	Available	PDHV
SYSRTC	Available	Available ⁶	-	PD0A
BURAM	Available	Available	Available	PDHV
MVP	Available	-	-	-
USART (UART/SPI)	Available	-	-	-
I ² C0	Available	Available ⁸	-	PD0D
I ² C1	Available	-	-	-
EUSART0	Available	Available ⁹	-	PD0D
EUSART1	Available	-	-	-
TIMER (Timer/Counter)	Available	-	-	-
LETIMER (Low Energy Timer)	Available	Available ⁶	-	PD0B
WDOG (Watchdog)	Available	Available ⁶	-	PD0D
ACMP (Analog Comparator)	Available	Available ⁷	-	PD0B
IADC (Analog to Digital Converter)	Available	Available ²	-	PD0B
VDAC (Digital-to-Analog Converter)	Available	Available ²	-	PD0B

	EM0 / EM1	EM2 / EM3	EM4	Low Power Domain
PCNT (Pulse Counter)	Available	Available ²	-	PD0B
KEYSCAN	Available	Available ¹⁰	-	PD0E
DC-DC	Available	Available	-	PD0A
EMU Temperature Sensor	Available	Available	-	PD0A
Brown-Out Detect/Power-on Reset	Available	Available	Available	-
Pin Reset	Available	Available	Available	-
PRS (Peripheral Reflex System)	Available	Available	-	PD0E
GPIO Pin Interrupts	Available	Available	Available ¹¹	-
GPIO Pin State Retention	Yes	Yes	Available ¹²	-

Note:

1. Leaving the debugger connected when in EM2 or EM3 will cause the system to enter a higher power EM2 mode in which the high frequency clocks are still enabled and certain core functionality is still powered-up in order to maintain debug-functionality.
2. The LDMA can be used with some low power peripherals (e.g., IADC) in EM2/3. Features required by the LDMA which are not supported in EM2/3 (e.g., HCLK), will be automatically enabled prior to the LDMA transfer and then automatically disabled afterwards.
3. EM2 Only. The RAC can be woken via a PRS interrupt to EM1 to transfer data. Once complete, the system will return to EM2.
4. Default off, but kept active if used by the IADC or VDAC.
5. Default off, but kept active if used by the BURTC
6. Must use ULFRCO in EM3 (LFRCO & LFXO not available in EM3)
7. ACMP functionality in EM2/3 limited to edge interrupt
8. I2C functionality limited to receive address recognition in EM2/3. Not supported on all GPIO Ports.
9. EUSART functionality limited to low-frequency UART or SPI secondary in EM2/3. Not supported on all GPIO Ports.
10. Wake on any key press supported in EM2/3. Full key scanning operates in EM0/1.
11. Pin wake-up in EM4 supported only on GPIO_EM4WUx pins. Consult data sheet for complete list of pins.
12. If enabled in EMU->EM4CTRL.EM4IORETMODE.

The different energy modes are summarized in the following sections.

12.3.1.1 EM0

EM0 provides all system features.

- Cortex®-M33 is executing code
- Radio functionality is available
- High and low frequency clock trees are active
- All oscillators are available
- All peripheral functionality is available

12.3.1.2 EM1

EM1 disables the core but leaves the remaining system fully available.

- Cortex®-M33 is in sleep mode. Clocks to the core are off
- Radio functionality is available
- High and low frequency clock trees are active
- All oscillators are available
- All peripheral functionality is available

12.3.1.3 EM1P

EM1P is a subset of EM1 which allows the radio to operate while the core and high-speed peripherals are shut down to save energy. It is entered when the radio is active and software requests to enter EM2.

- Cortex®-M33 is in sleep mode. Clocks to the core and all high-speed peripherals are off
- HFXO and radio (RX mode only) remain active
- All peripherals and oscillators capable of EM2, EM3 or EM4 operation are available

12.3.1.4 EM2

This is the first level into the low power energy modes. Most of the high frequency peripherals are disabled or have reduced functionality. Memory and registers retain their values.

- Cortex®-M33 is in sleep mode. Clocks to the core are off.
- Radio inactive
- High frequency clock tree is inactive
- Low frequency clock tree is active
- The following oscillators are available
 - LFRCO, LFXO, ULFRCO
 - On-demand if used by peripherals: FSRCO, HFRCOEM23
- The following low frequency peripherals are available
 - SYSRTC, BURTC, WDOG, LETIMER, PCNT, I2C0, EUSART0 (UART or SPI secondary only), and KEYSKAN
- The following analog peripherals are available (with potential limitations on functionality)
 - ACMP, IADC, VDAC
- Wake-up to EM0 through
 - Peripheral interrupt, reset pin, power on reset, asynchronous pin interrupt, I2C0 address recognition
- Wake-up to EM1 through
 - Peripheral data transfer request
 - Part returns to EM2 when transfers are complete
- RAM and register values are preserved
 - RAM blocks may be optionally powered down for lower power
- GPIO pin state is retained
- Debug connectivity is unavailable by default to reduce current consumption. Debug connectivity can be enabled by setting the EM2DBGGEN bit in the EMU_CTRL register, and will consume about 0.5 uA extra supply current.

12.3.1.5 EM3

In this low energy mode, all low frequency oscillators (LFXO, LFRCO) and all low frequency clocks derived from them are stopped, as well as all high frequency clocks. Most peripherals are disabled or have reduced functionality. Memory and registers retain their values.

- Cortex®-M33 is in sleep mode. Clocks to the core are off.
- Radio inactive
- High frequency clock tree is inactive
- All low frequency clock trees derived from the low frequency oscillators (LFXO, LFRCO) are inactive
- The following oscillators are available
 - ULFRCO
 - On-demand if used by peripherals: FSRCO, HFRCOEM23
- The following low frequency peripherals are available if clocked by the ULFRCO (with potential limitations on functionality)
 - SYSRTC, BURTC, WDOG, LETIMER, PCNT, I2C0, EUSART0 (SPI secondary only), and KEYSKAN
- The following analog peripherals are available (with potential limitations on functionality)
 - ACMP, IADC, VDAC
- Wake-up to EM0 through
 - Peripheral interrupt, reset pin, power on reset, asynchronous pin interrupt, I2C0 address recognition
- Wake-up to EM1 through
 - Peripheral data transfer request
 - Part returns to EM3 when transfers are complete
- RAM and register values are preserved
 - RAM blocks may be optionally powered down for lower power
- GPIO pin state is retained
- Debug connectivity is unavailable by default to reduce current consumption. Debug connectivity can be enabled by setting the EM2DBGEN bit in the EMU_CTRL register, and will consume about 0.5 uA extra supply current.

12.3.1.6 EM4

EM4 is the lowest energy mode of the part. There is no retention except for GPIO PAD state and BURAM values. Wake-up from EM4 requires a reset to the system, returning it back to EM0

- Cortex®-M33 is off
- Radio is off
- High frequency clock tree is off
- Low frequency clock tree may be active
- No RAM or register values are retained, except for the BURAM.
- The following oscillators are on if used by the BURTC:
 - LFRCO, LFXO, ULFRCO
- The following low frequency peripherals are available
 - BURTC
- Wake-up to EM0 through
 - BURTC interrupt, reset pin, power on reset, asynchronous pin interrupt (on GPIO_EM4WUx pins only)
- GPIO pin state may be retained (depending on EMU->EM4CTRL.EM4IORETMODE configuration)

12.3.2 Entering Low Energy Modes

The following sections describe the requirements for entering the various energy modes.

12.3.2.1 Entry Into EM1

Energy mode EM1 is entered when the Cortex®-M33 executes the Wait For Interrupt (WFI) or Wait For Event (WFE) instruction while the SLEEPDEEP bit in the Cortex®-M33 System Control Register is cleared. The MCU can re-enter sleep automatically out of an Interrupt Service Routine (ISR) if the SLEEPONEXIT bit in the Cortex®-M33 System Control Register is set. Refer to ARM documentation on entering Sleep modes.

Alternatively, EM1 can be entered from either EM2 or EM3 due to certain peripheral wake-up requests, allowing transfers from the peripheral to system RAM. The system will return back to EM2 or EM3 once the peripheral has completed its transfers and processing.

12.3.2.2 Entry Into EM2 or EM3

Energy mode EM2 or EM3 may be entered when **all** of the following conditions are true:

- Radio state machine is in OFF state
- Cortex®-M33 (if present) is in DEEPSLEEP state
- Flash Program/Erase Inactive
- DMA done with all current requests
- A debugger is not currently connected.

Note: The device will still enter a sleep state which emulates the behavior of EM2 or EM3 when an active debug connection is present, but it will draw more than the specified sleep current.

Energy mode EM2 is entered from EM0 when the Cortex®-M33 executes the Wait For Interrupt (WFI) or Wait For Event (WFE) instruction while the SLEEPDEEP bit in the Cortex®-M33 System Control Register is set. The MCU can re-enter DeepSleep automatically out of an Interrupt Service Routine (ISR) if the SLEEPONEXIT bit in the Cortex®-M33 System Control Register is set. Refer to ARM documentation on entering Sleep modes.

Alternately, EM2 or EM3 is entered from EM1 upon the completion of a Peripheral Wake-Up Request from capable peripherals if no EM0 wake-up happens in the meantime.

When entering EM2 or EM3, if any peripheral on an auxiliary low power domain (PD0B, PD0C, etc.) is enabled, that auxiliary low power domain will be powered, causing higher current draw. Otherwise, the auxiliary power domain will be powered down. See [12.3.4 Power Domains](#) for more information.

12.3.2.3 Entry Into EM4

Energy mode EM4 is entered through register access.

Software must ensure no modules are active, such as the Radio, when entering EM4.

Software may enter EM4 from EM0 by writing the sequence 2,3,2,3,2,3,2,3,2 to EM4CTRL->EM4ENTRY bit field. If the EM4BLOCK bit in WDOGn_CTRL is set, the CPU will be prevented from entering EM4 by software request.

An active debugger connection will prevent entry into EM4.

12.3.3 Exiting a Low Energy Mode

A system in EM2 and EM3 can be woken up to EM0 through regular interrupt requests from active peripherals. Since state and RAM retention is available, the EFR32 Series 2 is fully restored and can continue to operate as before it went into the Low Energy Mode.

Wake-up from EM4 is performed through a reset. Wake-up from a specific module must be enabled in that module's EM4WUEN register.

Enabled interrupts that can cause wake-up from EM2, EM3, and EM4 are shown in the following table. The wake-up triggers always return the device to EM0. Additionally, any reset source will return to EM0.

Table 12.3. Wake-Up Triggers from Low Energy Modes

Peripheral	Wake-Up Trigger	EM2	EM3	EM4
LETIMER	Any enabled interrupt	Yes	-	-
LFXO	Ready Interrupt	Yes	-	-
LFRCO	Ready Interrupt	Yes	-	-
WDOG	Any enabled interrupt	Yes	Yes	-
I ² C0	Receive address recognition	Yes	Yes	-
EUSART0	Any enabled interrupt	Yes	-	-
IADC	SCAN and SINGLE FIFO events, Window comparator events	Yes	Yes	
ACMP	Any enabled edge interrupt	Yes	Yes	-
VDAC	Any enabled interrupt except ABUS conflict and allocation interrupts	Yes	Yes	
SYSRTC	Any enabled interrupt	Yes	Yes	-
BURTC	Timeout	Yes	Yes	Yes ¹
EMU Temperature Sensor	Measured temperature outside the defined limits	Yes	Yes	-
Pin Interrupts	Transition	Yes ²	Yes ²	Yes ^{1 3}
Reset Pin	Assertion	Yes	Yes	Yes
Power	Cycle Off/On	Yes	Yes	Yes

Note:

1. Corresponding bit in the module's EM4WUEN must be set.
2. Available on Port A, Port B, and all EM4WU pins.
3. Only available on EM4WU pins.

12.3.4 Power Domains

Peripherals may exist on one of several independent power domains which are powered down to minimize supply current when not in use. Power domains are managed automatically by the EMU.

The lowest-energy power domain is the "high-voltage" power domain (PDHV), which supports extremely low-energy infrastructure and peripherals. Circuits powered from PDHV are always on and available in all energy modes down to EM4.

The next power domain is the low power domain (PD0), which is further divided to power subsets of peripherals. All PD0 power domains are shut down in EM4. Circuits powered from PD0 power domains may be available in EM0, EM1, EM2, and EM3.

Low power domain A (PD0A) is the base power domain for EM2 and EM3 and will always remain on in EM0-EM3. It powers the most commonly-used EM2 and EM3-capable peripherals and infrastructure required to operate in EM2 and EM3. Auxiliary PD0 power domains (PD0B, PD0C, PD0D, PD0E) power additional EM2 and EM3-capable peripherals on demand. If any peripherals on one of the auxiliary power domains is enabled, that power domain will be active in EM2 and EM3. Otherwise, the auxiliary PD0 power domains will be shut down to reduce current.

Note: Power domain PD0E is also turned on when peripherals on PD0B, PD0C, or PD0D are used.

The active power domain (PD1) powers the rest of the device circuitry, including the CPU core and EM0 / EM1 peripherals. PD1 is always powered on in EM0 and EM1. PD1 is always shut down in EM2, EM3, and EM4.

[Table 12.4 Peripheral Power Subdomains on page 298](#) shows the peripherals on the PDHV and PD0x domains. Any peripheral not listed is on PD1.

Table 12.4. Peripheral Power Subdomains

Always On in EM2/EM3		Selectively On in EM2/3			
PDHV ¹	PD0A	PD0B ²	PD0C ²	PD0D ²	PD0E
LFRCO (Non-precision Mode)	SYSRTC	LETIMER0	LFRCO (Precision Calibration Mode)	DEBUG	GPIO
LFXO	FSRCO	IADC0	HFRCOEM23	WDOG0/1	KEYSCAN
BURTC		PCNT0	HFXO	EUSART0	PRS
BURAM		ACMP0/1		I2C0	
ULFRCO		VDAC0/1			

Note:

1. Peripherals on PDHV are also available in EM4.
2. If any of PD0B, PD0C, or PD0D are enabled, PD0E will also be automatically enabled.

12.3.5 Voltage Scaling

The EFR32xG24 supports supply voltage scaling for the LDO powering DECOUPLE. Voltage scaling helps to optimize the energy efficiency of the system by operating at lower voltages when possible. Three supply voltage operating points are available:

Table 12.5. Voltage Scaling Options

VSCALE Setting	DECOUPLE Voltage	Operating Conditions
VSCALE2	1.1 V	EM0/EM1 Operation up to 80 MHz EM2 and EM3
VSCALE1	1.0 V	EM0/EM1 Operation up to 40 MHz EM2 and EM3
VSCALE0	0.9 V	EM2 and EM3 Only

12.3.5.1 Voltage Scaling in EM0 and EM1

In EM0 and EM1, the voltage scaling value should be set according to the desired operating frequency. The system defaults to VSCALE2 out of reset. To operate above 40 MHz, VSCALE2 should always be used. If the system will operate below 40 MHz, VSCALE1 may be used to save energy.

The voltage scaling value for EM0 and EM1 is changed via software command bits in the EMU_CMD register. Setting EMU_CMD_EM01VSCALE1 will switch to VSCALE1, and setting EMU_CMD_EM01VSCALE2 will switch to VSCALE2.

The command initiates a voltage change operation, but some time is needed before the new supply voltage is reached. When changing between VSCALE values in EM0, it takes approximately 150 us to ramp the voltage down and approximately 32 us to ramp the voltage up to the new values (see the data sheet specifications for exact numbers). During this time, SRAM access is prohibited by the hardware and any accesses to SRAM from the CPU or DMA will be blocked until the operation is complete. The EMU_STATUS_VSCALEBUSY bit indicates when a voltage scale change is in progress. When the operation is complete the EMU_IF_VSCALEDONEIF flag will be set.

Note: Because SRAM access is blocked during a voltage scaling operation, it is recommended to configure the desired EM0 / EM1 voltage scaling once during initial boot-up for systems operating at VSCALE1.

The current VSCALE setting can be read at any time from the EMU_STATUS_VSCALE field.

12.3.5.2 Voltage Scaling in EM2 and EM3

A separate voltage scaling value is used during EM2 and EM3. This allows the core to run at a higher voltage when in EM0 / EM1 and reduce the voltage in EM2 and EM3 for power savings, or maintain the same voltage for faster wakeup. The voltage scale level for EM2 and EM3 is defined by the EMU_CTRL_EMU23VSCALE field. The new voltage scaling level will be applied when the system is in EM2 or EM3, and return to the EM0 / EM1 voltage scaling level automatically when the system exits the low energy mode.

Hardware will only allow the VSCALE level to remain the same or be reduced when entering EM2 and EM3. If EMU_CTRL_EMU23VSCALE is set to a higher VSCALE setting than the current EM0 / EM1 VSCALE level, the DECOUPLE voltage will remain the same as the EM0 / EM1 setting.

If the voltage scaling level for EM2 / EM3 is lower than the level set for EM0 / EM1, additional time is needed to wake up from the low powered state (see the device data sheet for specific timing). The lowest current during sleep will be obtained by setting EMU23VSCALE to VSCALE0, and the fastest wake times will be obtained when EMU23VSCALE is equal to or higher than the EM0 / EM1 voltage scaling value.

12.3.6 EM0 / EM1 Peripheral Register Retention

When the device enters EM2 or EM3, all peripherals will retain their register configurations by default. Retention for peripherals on the PD1 power domain (i.e. those which do not operate in EM2 and EM3), can optionally be disabled by setting bit 0 of the EMU_PD1PARETCTRL_PD1PARETDIS field. Disabling retention reduces the supply current in EM2 and EM3 slightly. However, the peripheral register interfaces will be reset upon exit to EM0.

Important: This feature is not currently supported by Silicon Labs software stacks. It is the responsibility of the user software to re-configure any peripherals as necessary when the device wakes to EM0.

12.3.7 Power Configurations

In order to provide the lowest power solutions, the EFR32xG24 comes with a DC-DC module to power internal circuits. The EFR32xG24 may be operated with or without the DC-DC. When used, the DC-DC requires an external inductor and capacitor (refer to the data sheet for recommended values).

The EFR32xG24 has multiple power supply rails: a DC-DC regulator input (VREGVDD), IO Supply (IOVDD), Analog (AVDD), RF Analog Supply (RFVDD), RF Power Amplifier Supply (PAVDD), Digital LDO and flash (DVDD), and Low Voltage Digital Supply (DECOUPLE). Additional detail for each configuration and option is given in the following sections.

Due to on-chip circuitry (e.g., diodes), some power supply pins have a dependent relationship with one or more other power supply pins. These internal relationships between the external voltages applied to the various EFR32 supply pins are defined below. Exceeding the below constraints can result in damage to the device and/or increased current draw.

- VREGVDD \geq DVDD

Note: In systems not using the DC-DC converter, VREGVDD must be shorted to DVDD external to the device.

- PAVDD \geq RFVDD
- DVDD \geq DECOUPLE
- AVDD, IOVDD: No supply sequencing dependency. Additional leakage may occur if DVDD remains unpowered with power applied to these supplies.

Additionally, there are other system-level considerations when assigning power supplies.

- The usable range for analog signals connected to GPIO (such as IADC inputs) will be limited to the lower of AVDD and IOVDD.
- The RESETn pin has an internal pullup to the DVDD supply. If RESETn is driven by external circuitry above DVDD, additional current may flow into the pin due to this pullup.

12.3.7.1 Power Configuration 0: STARTUP

Upon power-on reset (POR), the system is configured in a safe Startup Configuration that supports all of the available Power Configurations. The Startup Configuration is shown in the simplified diagram below.

In the Startup configuration the DC-DC converter's Bypass switch is ON (i.e., the VREGVDD pin is shorted internally to the DVDD pin).

After power on, firmware can elect to turn on the DC-DC if the external hardware configuration supports it.

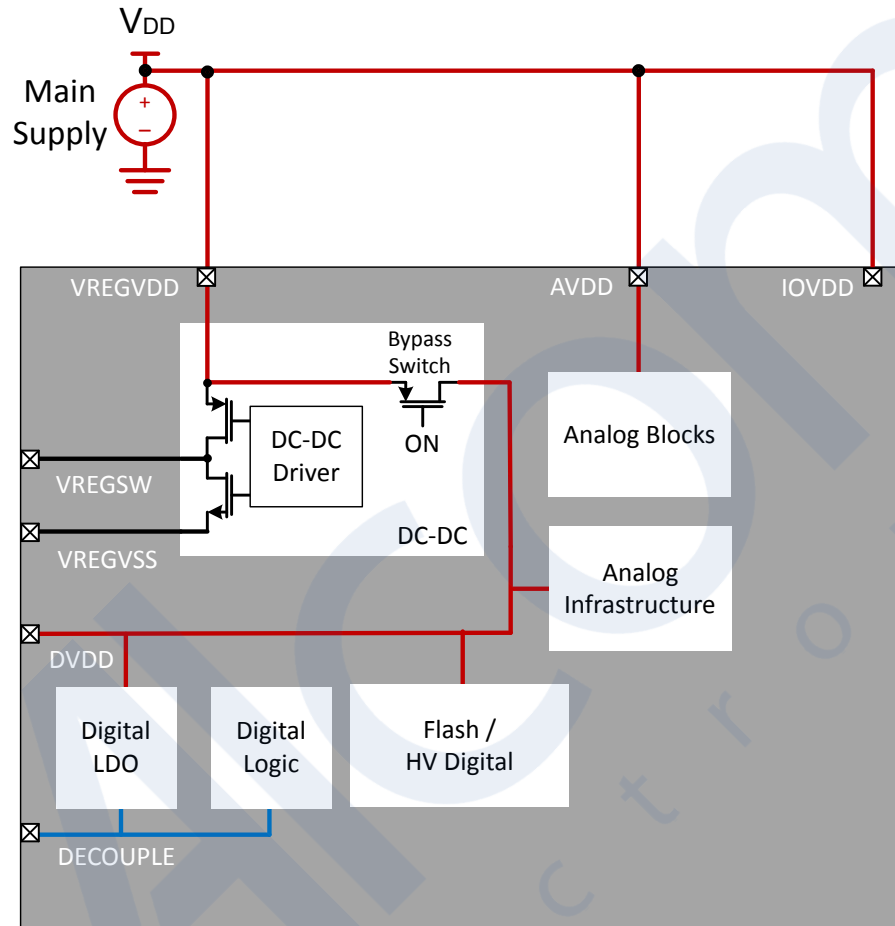

Figure 12.2. Startup Power Configuration

12.3.7.2 Power Configuration 1: No DC-DC

In Power Configuration 1, the DC-DC converter is unused, and all power is supplied by external sources. The DVDD pin must be shorted to VREGVDD.

Other supplies may be supplied by the same supply as VREGIN and DVDD (as shown in 12.3.7.2 Power Configuration 1: No DC-DC), or they may be powered from a separate source.

VREGSW must be left disconnected in this configuration.

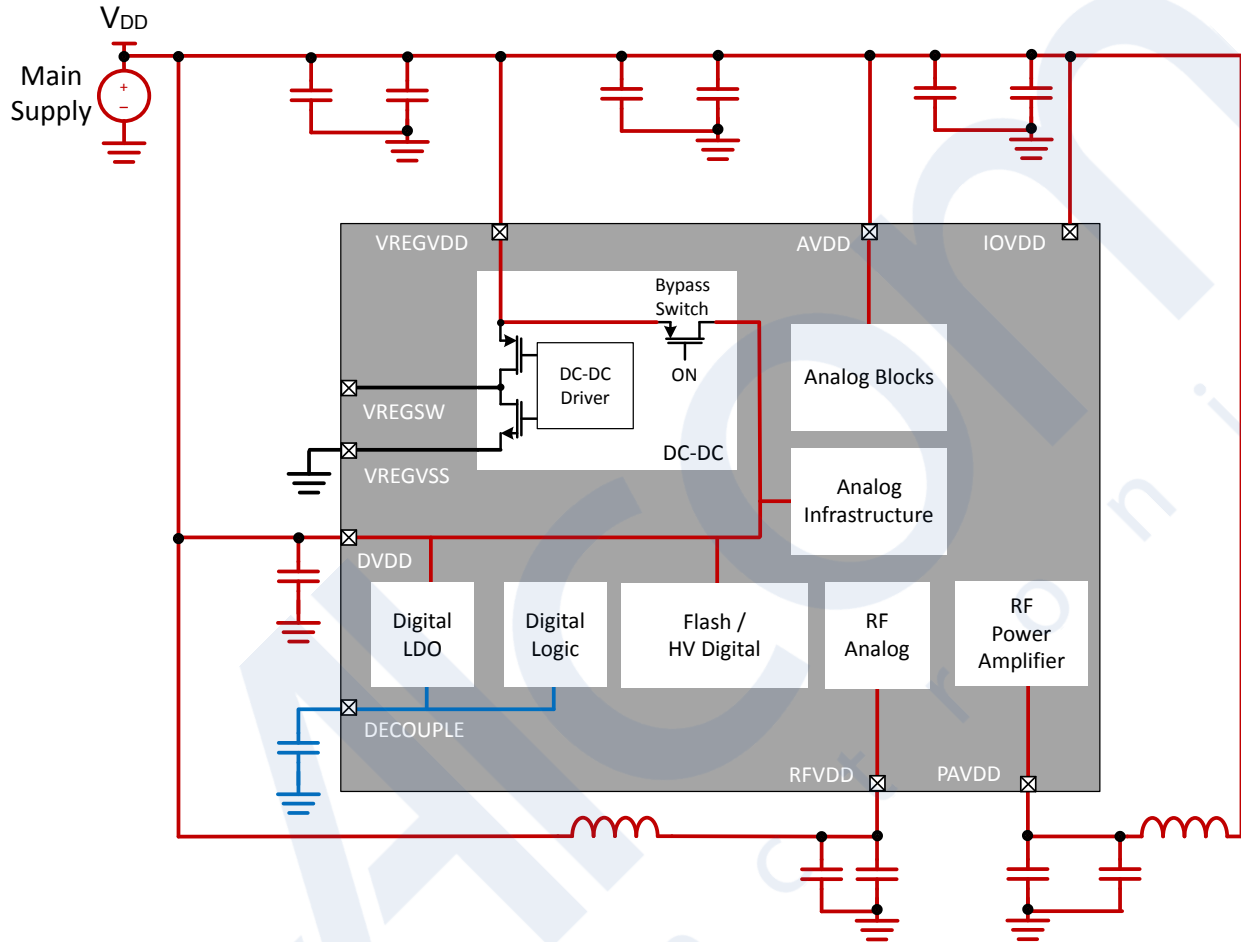

Figure 12.3. DC-DC Off Power Configuration

12.3.7.3 Power Configuration 2: DC-DC

For the lowest power applications, the DC-DC converter can be used to power the rest of the supplies on the device. When the DC-DC converter is used to regulate the voltage at DVDD, the maximum supply voltage may be limited by the operating temperature and/or the average lifetime load conditions. Refer to the device datasheet for additional details.

In Power Configuration 2, the DC-DC Output (V_{DCDC}) is connected to DVDD and optionally, to all the other supplies on the chip. In the configuration shown in [Figure 12.4 DC-DC Power Configuration on page 303](#), the AVDD and IOVDD supplies are connected to the main supply to support higher voltage external interfaces.

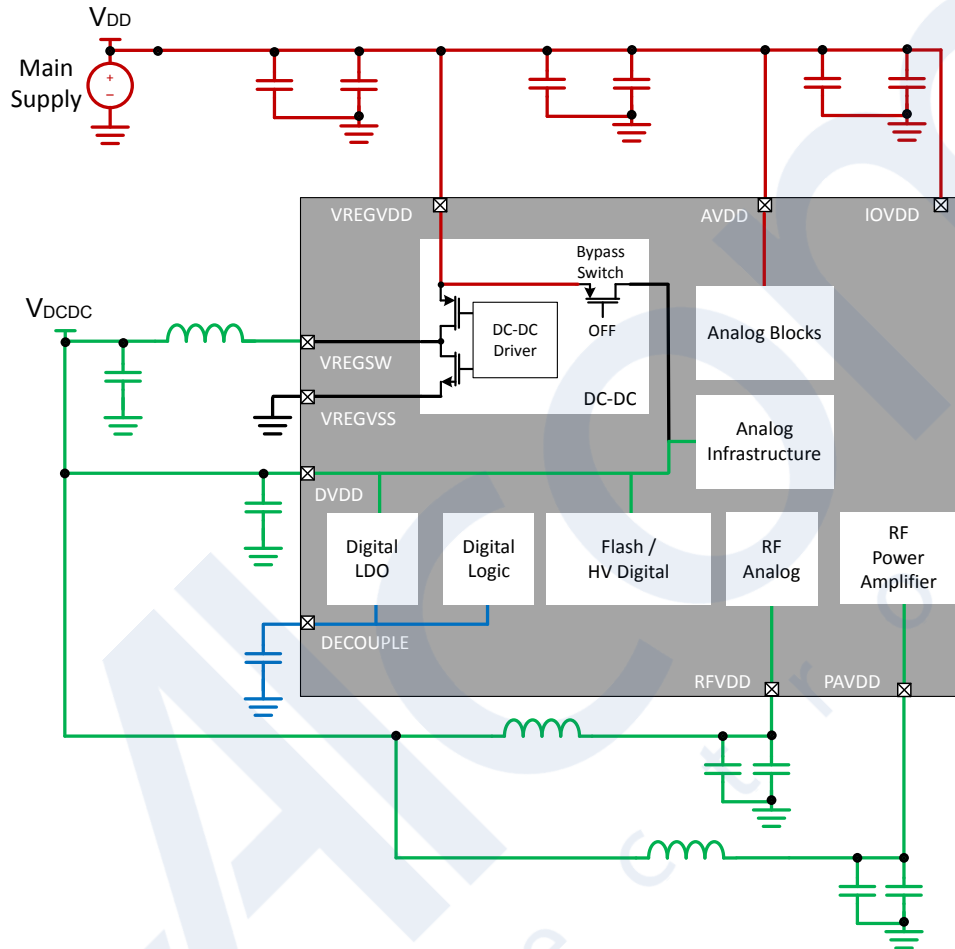

Figure 12.4. DC-DC Power Configuration

As the Main Supply voltage approaches the DC-DC output voltage, it eventually reaches a point where becomes inefficient (or impossible) for the DC-DC module to regulate V_{DCDC} . At this point, firmware can enable bypass mode, which effectively disables the DC-DC and shorts the Main Supply voltage directly to the DC-DC output. If and when sufficient voltage margin on the Main Supply returns, the system can be switched back into DC-DC regulation mode.

12.3.7.4 Power Configuration 3: DC-DC With Separate PAVDD

For power-conscious applications that require higher RF transmitter output power (> 14 dBm), PAVDD may be powered from the system supply, while the DC-DC converter can be used to power other supplies on the device. This situation is very similar to [12.3.7.3 Power Configuration 2: DC-DC](#), but PAVDD has been separated out to achieve higher transmitter power.

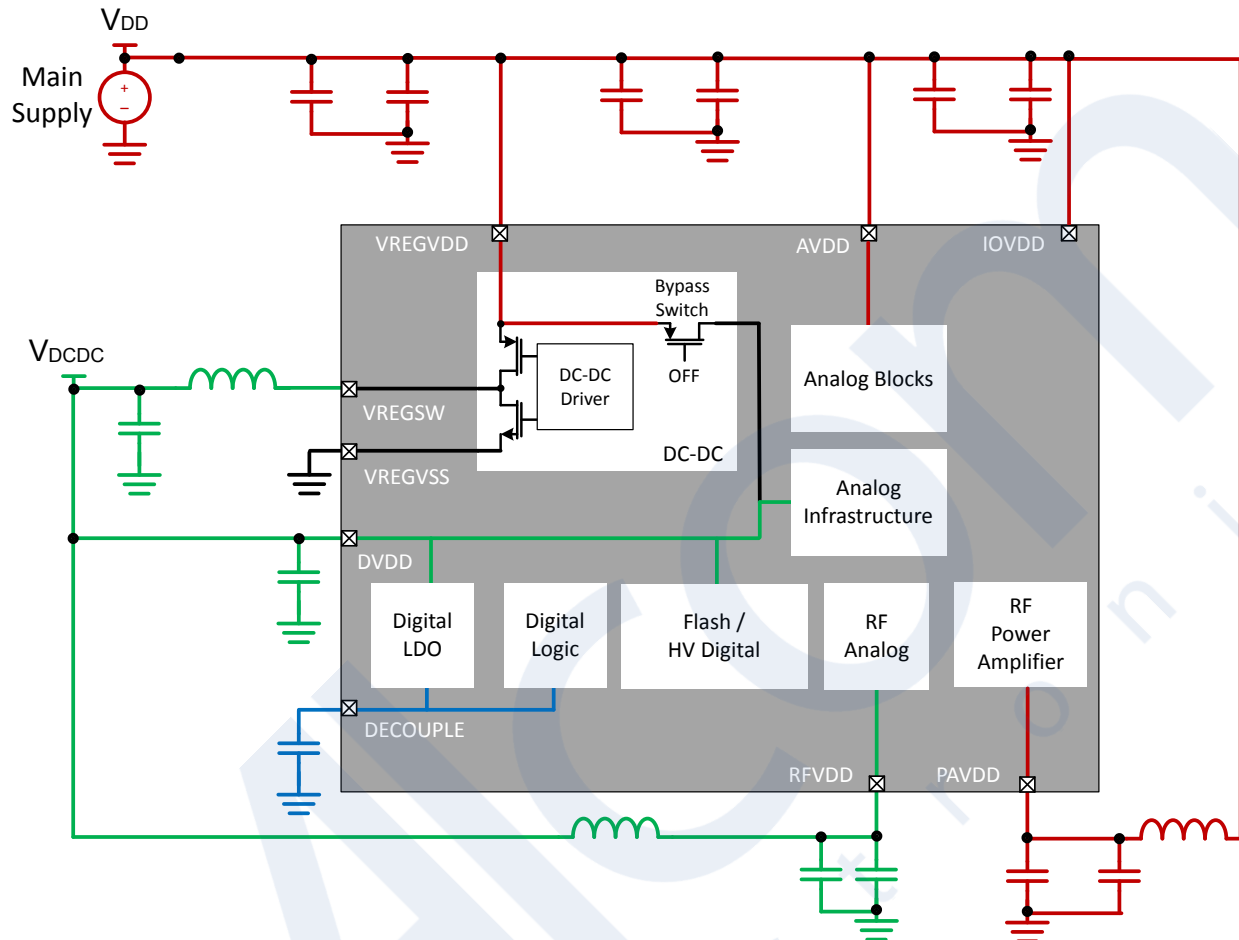

Figure 12.5. DC-DC Power Configuration With Separate PAVDD

12.3.8 Buck DC-DC Interface

The EFR32xG24 devices feature a DC-DC buck converter which requires a single external inductor and a single external capacitor. The input supply is the VREGVDD pin, and the DC-DC converter will produce a nominal 1.8 V output at the DVDD pin to power radio and MCU functions. The DC-DC converter is an efficient PFM (Pulse Frequency Modulation) architecture. In addition, the DC-DC converter supports an unregulated bypass mode, in which the input voltage is directly shorted to the DC-DC output. An integrated programmable supply monitor and dedicated interrupt allows software to enable the bypass switch when the VREGVDD supply voltage is below the minimum allowable voltage for the output current load.

The input supply VREGVDD has a maximum range between 1.8 V and 3.8 V, but is limited by application parameters, including transient current load, operating junction temperature, and the lifetime average current load.

Refer to the device datasheet for more details on the input supply voltage range.

12.3.8.1 Buck DC-DC Mode Bypass and VREGVDD Comparator

The buck DC-DC converter implements a bypass mode which shorts the VREGVDD input voltage directly to the DC-DC converter output through an internal switch. Bypass mode is enabled automatically during a power-on-reset. Bypass mode can also be enabled and disabled through software, using the DCDC_CTRL_MODE field. When set to BYPASS, the bypass switch is enabled and DC-DC regulation will be disabled. Consult the data sheet for the bypass switch impedance specification.

The EFR32xG24 includes a supply comparator circuit to help software determine when the VREGVDD supply is high enough to enable the buck DC-DC, or when to change to bypass mode. The THRESSEL field in the EMU_VREGVDDCMPCTRL register sets the comparator threshold between 2.0 and 2.3 V, and the VREGINCOMPEN bit is used to enable the supply comparator. When the VREGVDD comparator is used, DCDC_STATUS_VREGIN can be read by software to determine whether VREGVDD is above or below the established threshold.

The VREGVDD comparator can also generate interrupt events when the input supply is above or below the specified threshold. The VREGINHIGHIEN and VREGINLOWIEN bits in DCDC_IEN are used to enable the above / below threshold interrupts, respectively. The VREGVDD comparator will be active and generate interrupts in EM0 and EM1 only.

The VREGVDD Comparator status is always captured and stored in RMURSTCAUSE.VREGIN on any reset event, even if the reset is not caused by VREGVDD being too low. At startup, the firmware should determine if the last reset was caused by a low VREGVDD condition by checking the following:

```
EMU_RSTCAUSE_VREGIN & (EMU_RMURSTCAUSE_DVDDBOB | EMU_RMURSTCAUSE_DVDDLEBOD)
```

If true, the part should remain in bypass mode with the DCDC disabled.

12.3.8.2 Buck DC-DC Startup

Out of power-on-reset (POR), the DC-DC converter defaults to bypass mode and the DC-DC block is disabled. Before enabling the DC-DC, software should first configure and enable the VREGVDD comparator. Once the thresholds for the VREGVDD comparator have been configured and the comparator enabled, the DCDC_STATUS.VREGIN bit should be checked to ensure that the input supply is above the threshold. When the input supply is sufficient, the DC-DC may be configured and enabled. The following steps outline this procedure:

1. Set VREGVDD comparator threshold with EMU_VREGVDDCMPCTRL.THRESSEL
2. Enable VREGVDD comparator with EMU_VREGVDDCMPCTRL.VREGINCOMPEN
3. Check DCDC_STATUS.VREGIN:
 - If low, VREGIN is above the programmed threshold and it is safe to enter DC-DC mode
 - If high, VREGIN is below the programmed threshold and firmware should remain in bypass mode
4. Enable the DC-DC module with DCDC_EN_EN = 1
5. Configure the IPKVAL and DRVSPEED settings in DCDC_EM01CTRL0 and DCDC_EM23CTRL0.
6. Enable any required interrupts via DCDC_IEN.
7. Start the DC-DC by setting DCDC_CTRL.MODE to DCDCREGULATION.

The DC-DC will enter a warmup phase for approximately 100 us, then disable the bypass switch and begin using the DC-DC core to regulate the output voltage. The DCDC_IF.RUNNINGIF interrupt flag will indicate when the switch from bypass to DC-DC is complete, however this does not indicate that the output is regulated. Until the output capacitor discharges due to normal current draw from the system, the voltage may be higher than 1.8 V. The DCDC_IF.REGULATIONIF interrupt flag will indicate when the DC-DC has reached regulation and is providing the desired output voltage.

If the VREGINLOWIF interrupt occurs, software should immediately switch back to bypass mode by clearing DCDC_CTRL.MODE to BYPASS.

12.3.8.3 Buck DC-DC Recommended Configuration Settings

Certain DC-DC parameters are adjustable for fine-tuning of performance, but the majority of applications will not need to use any other than the recommended settings. All datasheet parameters are specified using the recommended settings detailed in this section. The configuration settings must be set before DC-DC regulation is started, and must not be changed while the DC-DC is active.

The DCDC_EM01CTRL0 and DCDC_EM23CTRL0 registers each have an IPKVAL field to adjust the maximum peak / load current, and a DRVSPEED field to adjust the driver speed. DCDC_EM01CTRL0 sets the configuration for EM0 and EM1 operation while DCDC_EM23CTRL0 sets the configuration for EM2 and EM3 operation. The DCDC_CTRL.IPKTMAXCTRL field adjusts the maximum time for peak current detection, which impacts the voltage ripple at the DC-DC output. The recommended settings are shown in [Table 12.6 DRVSPEED, IPKVAL, and IPKMAXCTRL Recommended Settings for buck DC-DC on page 306](#).

Table 12.6. DRVSPEED, IPKVAL, and IPKMAXCTRL Recommended Settings for buck DC-DC

Bit Field	Recommended Setting
DCDC_EM01CTRL0.IPKVAL	9 (LOAD60MA)
DCDC_EM01CTRL0.DRVSPEED	1 (DEFAULT_SETTING)
DCDC_EM23CTRL0.IPKVAL	3 (LOAD5MA)
DCDC_EM23CTRL0.DRVSPEED	1 (DEFAULT_SETTING)
DCDC_CTRL.IPKTMAXCTRL	16 (1.19 us)

12.3.8.4 Buck DC-DC EM4 Entry

The buck DC-DC is available in all energy modes except for EM4. If the system wants to enter EM4, the DC-DC converter must first be turned off and switched over to bypass mode. The system will not enter EM4 if the DC-DC is active. If an attempt is made to go into EM4 with DC-DC active, it will be blocked, and the DCDC_IF_EM4ERR flag will be set.

12.3.9 EFP01 Communication

The EFP01 Energy Friendly Power Management IC (PMIC) is an extremely flexible, highly efficient, multi-output power management IC, providing complete system power and primary cell battery Coulomb counting for EFR32xG24 devices. The dual-DCDC converter outputs available on certain EFP01 OPNs can, for example, provide power to both the 1.8 V supplies (e.g., DVDD/AVDD/IOVDD) as well as the 1.1/1.0/0.9 V supply (DECOUPLE) for improved efficiency. EFP01 uses an I2C interface for communication and also has a unidirectional, open-drain IRQ# output to indicate status flag changes. Consult EFP01 Datasheet for more detailed information and available OPNs.

The EFR32xG24 has additional built-in hardware support for the EFP01 Energy Friendly PMICs, including:

- Direct Mode Energy Mode transition supporting all energy modes (including EM4) on dedicated pins (PC1 / PC2)
- Hardware IRQ with (dedicated IRQ vector) in all energy modes (included EM4) on dedicated pin (PC5)

EFR32xG24's EFP01 hardware support must be enabled by setting one (or both) of the EFPDRVDECOUPLE or the EFPDRVDD bits in the EMU_CTRL register:

1. EFPDRVDECOUPLE: Set this bit if EFP01's DCDC output will be powering EFR32xG24's DECOUPLE supply. Once set, EFR32xG24's internal LDOs will be disabled, and any voltage changes (due to voltage-scaling and/or energy mode transitions) will be managed by EFP01. Note that because this bit disables in the internal LDO's powering the core, it should be set until after EFP01's DECOUPLE output has been configured and enabled.
2. EFPDRVDD: Set this bit if EFP01's DCDC output is powering EFR32xG24's DVDD supply (or DVDD along with other 1.8V supply inputs). This mode assumes that EFR32xG24's internal DCDC is not being used, so the EFR32xG24 VREGVDD and PAVDD pins should be shorted together on the PCB.

EFR32xG24 provides a dedicated hardware IRQ vector for the EFP01's IRQ output. To use the EFR32xG24's hardware support for EFP01's IRQ output:

1. The PC5 pin should be configured as an input with no pull-up/pull-down enabled and connected on the PCB to EFP01's IRQ pin. Note that although this pin exists on Port C, which typically doesn't support EM2/3 operation, when used as a EFP01 IRQ input the PC5 pin can operate in EM2/3. In addition, the PC5 pin can operate in EM4, without the need to be configured as a EM4Wakeup.
2. EFP01 Hardware support must be enabled by setting either the EFPDRVDECOUPLE or the EFPDRVDD bits as described above.

Once enabled, the EFP01 interrupt flag in the EMU_EFPIF register will be set whenever the EFP01 IRQ line goes low. A processor interrupt can be generated to the EMUEFP_IRQHandler() by setting the EFPIEN bit in the EMU_EFPIEN register.

EFR32xG24 includes hardware support for EFP01's optional Direct Mode interface to allow fast-energy mode transitions into and out of all energy modes (EM0/1, EM2/3, EM4). Ordinarily, I2C transactions are used to manage EFP01's energy mode state - however, a single I2C transaction can take over 100 us. In Direct Mode, the EFR32xG24 retasks the I2C pins as push-pull outputs with pull-ups disabled to control the EFP01's energy mode state directly, allowing much faster energy mode transitions. State definitions are defined in [Table 12.7 Direct Mode Energy Mode States on page 307](#). Because the Direct Mode feature is non-I2C compliant, it should be enabled only during periods when no communication between EFR32xG24 and EFP01 is required (e.g., an energy mode transition from EM0 to EM2/4), and it is recommended that EFP01 be the only I2C device on the bus. It is also recommended for firmware to wait for the I2C STOP interrupt ensure no I2C transaction is in progress before switching to Direct Mode.

Table 12.7. Direct Mode Energy Mode States

Direct Mode State	I2C SCL Level	I2C SDA Level	Allowed State Transitions
EM0	1	1	<ul style="list-style-type: none"> • EM2 • I²C Start Condition
EM2	0	1	<ul style="list-style-type: none"> • EM0 • EM4
EM4	0	0	<ul style="list-style-type: none"> • EM2²
I ² C Start Condition	1	0	

- 1 Direct mode transitions between EM0 and EM4 are not allowed. The system must briefly go through the EM2 state on EM4 exit or entrance.
- 2 Direct mode transitions between EM0 and EM4 are not allowed. The system must briefly go through the EM2 state on EM4 exit or entrance.

To enable Direct Mode:

1. The I2C1 module must be used to communicate with EFP01. I2C0 is not supported.
2. The I2C1_SDA function must be routed to the PC1 pin and connected on the PCB to EFP01's I2C_SDA pin.
3. The I2C1_SCL function must be routed to the PC2 pin and connected on the PCB to EFP01's I2C_SCL pin.
4. Direct Mode must be enabled by setting the EFPDIRECTMODEN bit in the EMU_CTRL register. The EMU will automatically disable the I2C1 internal pull-ups when in Direct Mode
5. EFP01 Hardware support must be enabled by setting either the EFPDRVDECOUPLE or the EFPDRVDD bits as described above.

12.3.10 Brown Out Detector (BOD)

Brown out detectors ensure that the minimum supply required for the chip to operate properly and safely is provided to the EFR32xG24. Once triggered, a BOD will generate a system reset.

All BODs detect when the supply falls below a programmed threshold except DECOVMBOD (Over Voltage Monitoring), which detects when the supply goes above a predefined threshold.

All BODs except DVddbOD and DVDDLEBOD can be individually enabled by firmware.

Table 12.8. EFR32xG24 BODs

BOD	Control Register	Supported Energy Modes	Function
DVddbOD	n/a	EM0/1	Monitors the DVDD supply in EM0 and EM1. Hardware enables this BOD automatically in EM0/EM1 and disables it in EM2/EM3/EM4
DVDDLEBOD	n/a	EM2/3/4	Low Energy BOD monitors the DVDD supply in EM2/EM3/ EM4. DVDDLEBOD is automatically masked by hardware for ~100us after it is enabled to allow it to settle
DECBOD	EMU_DECBOD	EM0/1/2/3	Monitors the DECOUPLE supply. DECBOD is automatically masked by hardware for ~20us after it is enabled to allow it to settle.
DECOVMBOD	EMU_DECBOD	EM0/1/2/3	Monitors the DECOUPLE supply Over Voltage by detecting DECOUPLE going over a specified threshold. DECOVMBOD is automatically masked by hardware for ~20us after it is enabled to allow it to settle.
AVddbOD	EMU_BOD3SENSE	EM0/1/2/3/4	Monitors the AVDD supply. Automatically masked by hardware for ~100us after it is enabled to allow it to settle.
IOVddbOD	EMU_BOD3SENSE	EM0/1/2/3/4	Monitors the IOVDD supply. Automatically masked by hardware for ~100us after it is enabled to allow it to settle. (Note that some devices may have multiple IOVDD supplies.)

12.3.11 Reset Management Unit

EMU RMU (Reset Management Unit) ensures correct reset operation. It is responsible for connecting the different reset sources to the reset lines of the EFR32xG24. After reset, the M33 loads the stack pointer and program entry point from memory and start execution.

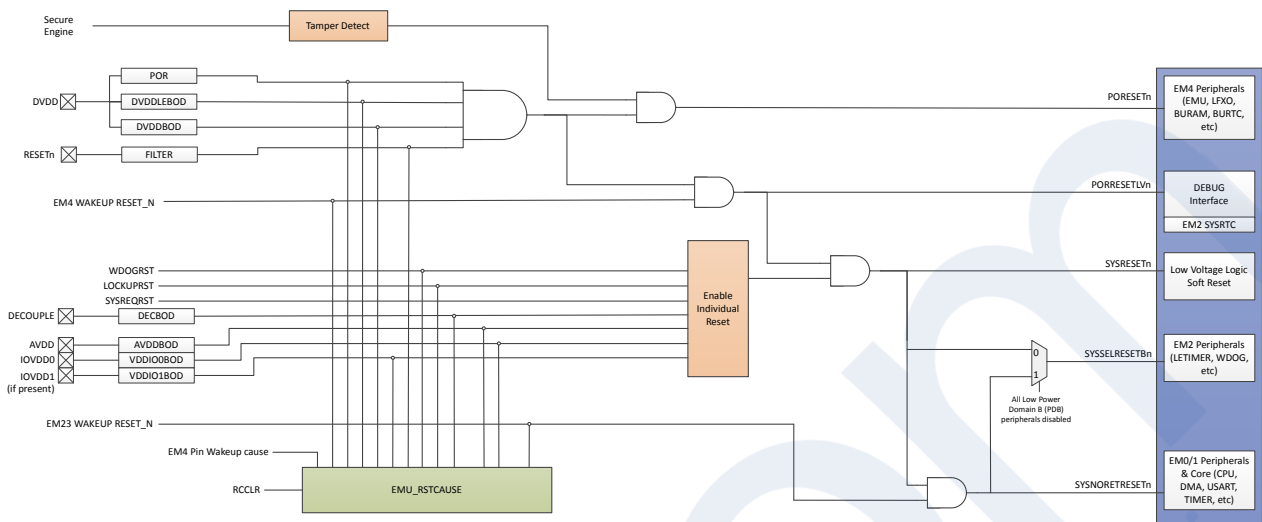

Figure 12.6. Reset Tree

There are two types of reset:

- **HARD resets.** Resets the entire chip. After a hard reset, the EFR32xG24 goes through its power up sequence. For reset timing specifications, please refer to the device datasheet.
- **SOFT resets.** Resets only some of the digital low voltage logic. Resets the MCU subsystems and peripherals but doesn't affect digital HV logic (e.g., Power control, BURTC). For reset timing specifications, please refer to the device datasheet.

EFR32xG24 Reset sources

- Power-on Reset (POR)
 - The POR ensures that EFR32xG24 does not start up before the supply voltage DVDD has reached the threshold voltage VPORthr (see Device Datasheet Electrical Characteristics for details). Before the threshold voltage is reached, EFR32xG24 is kept in reset state.
- RESET pin Reset
 - The RESEn pin includes an on-chip pull-up resistor to the DVDD supply, and can therefore be left unconnected if no external reset source is needed. Also connected to the RESEn line is a filter which prevents glitches from resetting the EFR32xG24.
- EM4 wakeup
 - System reset following EM4 exit.
- Watchdog reset
 - The Watchdog circuit is a timer which (when enabled) must be cleared by software regularly. If software does not clear it, a Watchdog reset is activated. This functionality provides recovery from a software stalemate. Refer to the Watchdog section for specifications and description.
- Core lockup condition
 - A MCU lockup is the result of the core being locked up because of an unrecoverable exception following the activation of the processor's built-in system state protection hardware.
- Software triggered reset
 - Software may initiate a reset (e.g. if it finds itself in a non-recoverable state). By asserting the SYSRESETREQ in the Application Interrupt and Reset Control Register, a reset is issued.
- Brown-Out Detection (BOD)
 - EFR32xG24 has multiple built in Brown-out detection (BOD) circuits, which monitor supply voltage level during operation. BOD circuits compare supply voltage to a programmed threshold level and issue a reset request when triggered.
- Secure Engine Tamper detection
 - Secure Engine may issue a system reset request upon tamper detection.

Whether a reset source trigger event lead to a system reset can be controlled via EMU_RMUCTRL register. EMU_RSTCAUSE register

User can determine the cause of the last reset by querying the EMU_RSTCAUSE register. Once read, EMU_RSTCAUSE should be cleared via EMU_CMD_RCCLR.

Table 12.9. Reset Sources Summary

RSTCAUSE Bit	Name	Type	Can be Disabled?	Description
0	POR	Hard	No	Power On Reset.
1	PIN	Hard	No	Pin Reset.
2	EM4	Soft	No	EM4 Wakeup
3	WDOG0	Soft	Yes	Watchdog 0
5	LOCKUP	Soft	Yes	M33 Lockup
6	SYSREQ	Soft	Yes	M33 Core System Reset
7	DVddbOD	Hard	No	DVDD BOD
8	DVDDLEBOD	Hard	No	DVDD LEBOD
9	DECBOD	Hard	Yes	DECOUPLE BOD
10	AVddbOD	Soft	Yes	AVDD BOD
11	IOVddbOD	Soft	Yes	IOVDD 0 BOD

12.3.12 Temperature Sensor

EMU provides a low energy periodic temperature measurement. A temperature measurement is taken once every 250 ms, with the 9-bit result stored in TEMP bit-field in EMU_TEMP register. The temperature value is expressed in degrees Kelvin. EMU_TEMP_TEMPLSB represents the measured temperature fractional part (in ¼ degree Kelvin).

Note: The EMU temperature sensor is always periodically taking single temperature measurements, except in EM4 (shutoff) mode.

To obtain better noise resolution, the temperature sensor also implements a hardware averaging function, and averaged results can be requested using the EMU_CMD_TEMPavgREQ command. When TEMPavgREQ is set by software, the temperature sensor will take 16 or 64 samples as quickly as possible. The TEMPavgNUM field in EMU_CTRL determines how many temperature measurements will be averaged. The averaged result is stored in the 11-bit field EMU_TEMP_TEMPavg, which represents the full temperature with resolution of ¼ degree Kelvin.

The EMU provides the following features around temperature changes:

- Interrupt when temperature is updated (EMU_IF_TEMP)
- Interrupt when averaged temperature result is updated (EMU_IF_TEMPavg)
- Interrupt from LOW level trip (generate interrupt EMU_IF_TEMPLOWIF when measured temperature in EMU_TEMP_TEMP is below programmed threshold EMU_TEMPLIMITS_TEMPLOW)
- Interrupt from HIGH level trip (generate interrupt EMU_IF_TEMPHIGHIF when measured temperature in EMU_TEMP_TEMP is above programmed threshold EMU_TEMPLIMITS_TEMPHI)

High and Low thresholds are specified as 9-bit degree Kelvin values and compared against the single temperature result (EMU_IF_TEMP).

Measured temperature can be converted to degrees Celsius by subtracting 273.15 ($T_{\text{Celsius}} = T_{\text{Kelvin}} - 273.15$).

12.3.12.1 Linearization, Offset Correction, and Calibration

The raw value reported by the EMU temperature sensor follows a predictable curve. The output may be linearized and the systematic offset removed to achieve die temperature readings with better than +/- 2.5 degrees C accuracy over the full operating temperature range. Further accuracy can be achieved using in-system calibration.

To linearize the measurement and correct for the systematic offset, a second or third-order polynomial equation representing the nominal curve is used. For example, a third-order correction equation takes the form:

$$T_{\text{corr}} = a \cdot x^3 + b \cdot x^2 + c \cdot x^1 + d$$

Where:

- T_{corr} is the corrected temperature (in degrees Celsius)
- x is the measured temperature (in degrees Celsius)
- a is the x^3 term
- b is the x^2 term
- c is the x^1 term
- d is the x^0 term

Polynomial coefficients for both third and second-order polynomials are shown in [Table 12.10 Polynomial Coefficients on page 311](#). Note that the polynomial coefficients provided assume the raw output (in Kelvin) has been converted to Celsius prior to linearization.

Table 12.10. Polynomial Coefficients

Polynomial Order	x^3 Term	x^2 Term	x^1 Term	x^0 Term
Third Order	-9.939E-7	-1.526E-4	1.040	-3.577
Second Order	n/a	-2.849E-4	1.040	-3.374

Additional accuracy may be achieved by performing an in-system calibration at known temperatures and operating conditions after linearization.

12.3.13 Register Locks

EMU EMU_LOCK (for user accessible registers) can be used to control access to the EMU_RMUCTRL, EMU_CTRL, and EMU_DEC-BOD registers. The DCDC_LOCK register can be used to control access to the DC-DC registers.



12.4 EMU Register Map

The offset register address is relative to the registers base address.

Offset	Name	Type	Description
0x010	EMU_DECBOD	RW	DECOUPLE LVBOD Control Register
0x020	EMU_BOD3SENSE	RW	BOD3SENSE Control Register
0x03C	EMU_VREGVDDCMPCTRL	RW	DC-DC VREGVDD Comparator Control Register
0x040	EMU_PD1PARETCTRL	RW	PD1 Partial Retention Control
0x05C	EMU_IPVERSION	R	IP Version
0x060	EMU_LOCK	W	EMU Configuration Lock Register
0x064	EMU_IF	RWH INTFLAG	Interrupt Flags
0x068	EMU_IEN	RW	Interrupt Enables
0x06C	EMU_EM4CTRL	RW	EM4 Control
0x070	EMU_CMD	W	EMU Command Register
0x074	EMU_CTRL	RW	EMU Control Register
0x078	EMU_TEMPLIMITS	RW	EMU Temperature Thresholds
0x084	EMU_STATUS	RH	EMU Status Register
0x088	EMU_TEMP	RH	Temperature
0x090	EMU_RSTCTRL	RW	Reset Management Control Register
0x094	EMU_RSTCAUSE	RH	Reset Cause
0x098	EMU_TAMPERRSTCAUSE	RH	Tamper Reset Cause
0x0A0	EMU_DGIF	RWH INTFLAG	Interrupt Flags Debug
0x0A4	EMU_DGIEN	RW	Interrupt Enables Debug
0x100	EMU_EFPIF	RWH INTFLAG	EFP Interrupt Register
0x104	EMU_EFPIEN	RW	EFP Interrupt Enable Register
0x1010	EMU_DECBOD_SET	RW	DECOUPLE LVBOD Control Register
0x1020	EMU_BOD3SENSE_SET	RW	BOD3SENSE Control Register
0x103C	EMU_VREGVDDCMPCTRL_SET	RW	DC-DC VREGVDD Comparator Control Register
0x1040	EMU_PD1PARETCTRL_SET	RW	PD1 Partial Retention Control
0x105C	EMU_IPVERSION_SET	R	IP Version
0x1060	EMU_LOCK_SET	W	EMU Configuration Lock Register
0x1064	EMU_IF_SET	RWH INTFLAG	Interrupt Flags
0x1068	EMU_IEN_SET	RW	Interrupt Enables
0x106C	EMU_EM4CTRL_SET	RW	EM4 Control
0x1070	EMU_CMD_SET	W	EMU Command Register
0x1074	EMU_CTRL_SET	RW	EMU Control Register
0x1078	EMU_TEMPLIMITS_SET	RW	EMU Temperature Thresholds
0x1084	EMU_STATUS_SET	RH	EMU Status Register

Offset	Name	Type	Description
0x1088	EMU_TEMP_SET	RH	Temperature
0x1090	EMU_RSTCTRL_SET	RW	Reset Management Control Register
0x1094	EMU_RSTCAUSE_SET	RH	Reset Cause
0x1098	EMU_TAMPERRSTCAUSE_SET	RH	Tamper Reset Cause
0x10A0	EMU_DGIF_SET	RWH INTFLAG	Interrupt Flags Debug
0x10A4	EMU_DGIEN_SET	RW	Interrupt Enables Debug
0x1100	EMU_EFPIF_SET	RWH INTFLAG	EFP Interrupt Register
0x1104	EMU_EFPIEN_SET	RW	EFP Interrupt Enable Register
0x2010	EMU_DECBOD_CLR	RW	DECOUPLE LVBOD Control Register
0x2020	EMU_BOD3SENSE_CLR	RW	BOD3SENSE Control Register
0x203C	EMU_VREGVDDCMPCTRL_CLR	RW	DC-DC VREGVDD Comparator Control Register
0x2040	EMU_PD1PARETCTRL_CLR	RW	PD1 Partial Retention Control
0x205C	EMU_IPVERSION_CLR	R	IP Version
0x2060	EMU_LOCK_CLR	W	EMU Configuration Lock Register
0x2064	EMU_IF_CLR	RWH INTFLAG	Interrupt Flags
0x2068	EMU_IEN_CLR	RW	Interrupt Enables
0x206C	EMU_EM4CTRL_CLR	RW	EM4 Control
0x2070	EMU_CMD_CLR	W	EMU Command Register
0x2074	EMU_CTRL_CLR	RW	EMU Control Register
0x2078	EMU_TEMPLIMITS_CLR	RW	EMU Temperature Thresholds
0x2084	EMU_STATUS_CLR	RH	EMU Status Register
0x2088	EMU_TEMP_CLR	RH	Temperature
0x2090	EMU_RSTCTRL_CLR	RW	Reset Management Control Register
0x2094	EMU_RSTCAUSE_CLR	RH	Reset Cause
0x2098	EMU_TAMPER-RSTCAUSE_CLR	RH	Tamper Reset Cause
0x20A0	EMU_DGIF_CLR	RWH INTFLAG	Interrupt Flags Debug
0x20A4	EMU_DGIEN_CLR	RW	Interrupt Enables Debug
0x2100	EMU_EFPIF_CLR	RWH INTFLAG	EFP Interrupt Register
0x2104	EMU_EFPIEN_CLR	RW	EFP Interrupt Enable Register
0x3010	EMU_DECBOD_TGL	RW	DECOUPLE LVBOD Control Register
0x3020	EMU_BOD3SENSE_TGL	RW	BOD3SENSE Control Register
0x303C	EMU_VREGVDDCMPCTRL_TGL	RW	DC-DC VREGVDD Comparator Control Register
0x3040	EMU_PD1PARETCTRL_TGL	RW	PD1 Partial Retention Control
0x305C	EMU_IPVERSION_TGL	R	IP Version
0x3060	EMU_LOCK_TGL	W	EMU Configuration Lock Register

Offset	Name	Type	Description
0x3064	EMU_IF_TGL	RWH INTFLAG	Interrupt Flags
0x3068	EMU_IEN_TGL	RW	Interrupt Enables
0x306C	EMU_EM4CTRL_TGL	RW	EM4 Control
0x3070	EMU_CMD_TGL	W	EMU Command Register
0x3074	EMU_CTRL_TGL	RW	EMU Control Register
0x3078	EMU_TEMPLIMITS_TGL	RW	EMU Temperature Thresholds
0x3084	EMU_STATUS_TGL	RH	EMU Status Register
0x3088	EMU_TEMP_TGL	RH	Temperature
0x3090	EMU_RSTCTRL_TGL	RW	Reset Management Control Register
0x3094	EMU_RSTCAUSE_TGL	RH	Reset Cause
0x3098	EMU_TAMPERRSTCAUSE_TGL	RH	Tamper Reset Cause
0x30A0	EMU_DGIF_TGL	RWH INTFLAG	Interrupt Flags Debug
0x30A4	EMU_DGIEN_TGL	RW	Interrupt Enables Debug
0x3100	EMU_EFPIF_TGL	RWH INTFLAG	EFP Interrupt Register
0x3104	EMU_EFPIEN_TGL	RW	EFP Interrupt Enable Register

12.5 EMU Register Description

12.5.1 EMU_DECBOB - DECOUPLE LVBOD Control Register

Offset	Bit Position																															
0x010	31	30	29	28	27	26	25	24	23	22	21	20	19	18	17	16	15	14	13	12	11	10	9	8	7	6	5	4	3	2	1	0
Reset																											0x1	0x0			0x1	0x0
Access																											RW	RW			RW	RW
Name																											DECOVBODMASK	DECOVBODEN			DECBODMASK	DECBODEN

Bit	Name	Reset	Access	Description
31:6	<i>Reserved</i>	<i>To ensure compatibility with future devices, always write Reserved bits to their reset value, unless otherwise stated. More information in 1.2 Conventions</i>		
5	DECOVBODMASK DECOUPLE BOD Over Voltage Monitor Mask	0x1	RW	Over Voltage Monitor Mask
4	DECOVBODEN DECOUPLE BOD Over Voltage Monitor enable. Enables LVBOD below vref high. BOD is masked for 20us after enable	0x0	RW	Over Voltage Monitor enable
3:2	<i>Reserved</i>	<i>To ensure compatibility with future devices, always write Reserved bits to their reset value, unless otherwise stated. More information in 1.2 Conventions</i>		
1	DECBODMASK DECOUPLE BOD Mask	0x1	RW	DECBOD Mask
0	DECBODEN DECOUPLE BOD enable. Enables LVBOD above vref low. BOD is masked for 20us after enable	0x0	RW	DECBOD enable

12.5.2 EMU_BOD3SENSE - BOD3SENSE Control Register

Offset	Bit Position																															
0x020	31	30	29	28	27	26	25	24	23	22	21	20	19	18	17	16	15	14	13	12	11	10	9	8	7	6	5	4	3	2	1	0
Reset																											0x0	0x0	0x0			
Access																											RW	RW	RW			
Name																											VDDIO1BODEN	VDDIO0BODEN	AVDDBODEN			

Bit	Name	Reset	Access	Description
31:3	<i>Reserved</i>	<i>To ensure compatibility with future devices, always write Reserved bits to their reset value, unless otherwise stated. More information in 1.2 Conventions</i>		
2	VDDIO1BODEN	0x0	RW	VDDIO1 BOD enable BOD output is automatically masked for 100us by HW after enable is set
1	VDDIO0BODEN	0x0	RW	VDDIO0 BOD enable BOD output is automatically masked for 100us by HW after enable is set
0	AVDDBODEN	0x0	RW	AVDD BOD enable BOD output is automatically masked for 100us by HW after enable is set

12.5.3 EMU_VREGVDDCMPCTRL - DC-DC VREGVDD Comparator Control Register

Offset	Bit Position																															
0x03C	31	30	29	28	27	26	25	24	23	22	21	20	19	18	17	16	15	14	13	12	11	10	9	8	7	6	5	4	3	2	1	0
Reset																											0x3	0x0				
Access																											RW	RW				
Name																											THRESSEL	VREGINCPEN				

Bit	Name	Reset	Access	Description
31:3	<i>Reserved</i>	<i>To ensure compatibility with future devices, always write Reserved bits to their reset value, unless otherwise stated. More information in 1.2 Conventions</i>		
2:1	THRESSEL	0x3	RW	VREGVDD comparator threshold programming VREGVDD comparator threshold programming: 2.0->2.3V, 0.1V/step
0	VREGINCPEN	0x0	RW	VREGVDD comparator enable VREGVDD comparator enable. Output is masked for 5us after enabled. Automatically disabled in EM2.

12.5.4 EMU_PD1PARECTRL - PD1 Partial Retention Control

Offset	Bit Position																															
0x040	31	30	29	28	27	26	25	24	23	22	21	20	19	18	17	16	15	14	13	12	11	10	9	8	7	6	5	4	3	2	1	0
Reset																	0x0															
Access																	RW															
Name																	PD1PARETDIS															

Bit	Name	Reset	Access	Description									
31:16	Reserved	<i>To ensure compatibility with future devices, always write Reserved bits to their reset value, unless otherwise stated. More information in 1.2 Conventions</i>											
15:0	PD1PARETDIS	0x0	RW	Disable PD1 Partial Retention Select PD1 register groups that are NOT retained in EM2/EM3. Each bit controls a register group. MCU core group is always retained. Bit[0]: Disables PD1 retention for MCU Peripherals group. Bit[1]: Disables PD1 retention for RADIO group (only on devices with a radio). Bit [15:2]: Unused. Setting PD1 retention for MCU Peripherals group will also allow PD0B/C/D power domains to be turned OFF in EM23 if all peripherals on those power domains are turned off on EM23 entry <table border="1"> <thead> <tr> <th>Value</th> <th>Mode</th> <th>Description</th> </tr> </thead> <tbody> <tr> <td>1</td> <td>PERIPHNORETAIN</td> <td>Retain associated registers when in EM2/3</td> </tr> <tr> <td>2</td> <td>RADIONORETAIN</td> <td>Bit[1]. When set, do not retain RADIO associated registers when in EM2/3</td> </tr> </tbody> </table>	Value	Mode	Description	1	PERIPHNORETAIN	Retain associated registers when in EM2/3	2	RADIONORETAIN	Bit[1]. When set, do not retain RADIO associated registers when in EM2/3
Value	Mode	Description											
1	PERIPHNORETAIN	Retain associated registers when in EM2/3											
2	RADIONORETAIN	Bit[1]. When set, do not retain RADIO associated registers when in EM2/3											

12.5.5 EMU_IPVERSION - IP Version

Offset	Bit Position																															
0x05C	31	30	29	28	27	26	25	24	23	22	21	20	19	18	17	16	15	14	13	12	11	10	9	8	7	6	5	4	3	2	1	0
Reset																	0x3															
Access																	R															
Name																	IPVERSION															

Bit	Name	Reset	Access	Description
31:0	IPVERSION IP Version	0x3	R	IP Version

12.5.6 EMU_LOCK - EMU Configuration Lock Register

Offset	Bit Position																															
0x060	31	30	29	28	27	26	25	24	23	22	21	20	19	18	17	16	15	14	13	12	11	10	9	8	7	6	5	4	3	2	1	0
Reset																	0xADE8															
Access																	W															
Name																	LOCKKEY															

Bit	Name	Reset	Access	Description
31:16	Reserved	To ensure compatibility with future devices, always write Reserved bits to their reset value, unless otherwise stated. More information in 1.2 Conventions		
15:0	LOCKKEY	0xADE8	W	Lock Key Write any other value than the unlock code to lock
	Value	Mode		Description
	44520	UNLOCK		Unlock EMU register

12.5.7 EMU_IF - Interrupt Flags

Offset	Bit Position																																
0x064	31	30	29	28	27	26	25	24	23	22	21	20	19	18	17	16	15	14	13	12	11	10	9	8	7	6	5	4	3	2	1	0	
Reset	0x0	0x0	0x0		0x0		0x0	0x0							0x0	0x0																	
Access	RW	RW	RW		RW		RW	RW							RW	RW																	
Name	TEMPHIGH	TEMPLOW	TEMP		TEMPAVG		VSCALEDONE	EM23WAKEUP							IOVDD0BOD	AVDDDBOD																	

Bit	Name	Reset	Access	Description
31	TEMPHIGH	0x0	RW	Temperature high Interrupt flag Measured temperature above threshold
30	TEMPLOW	0x0	RW	Temperature low Interrupt flag Measured temperature below threshold
29	TEMP	0x0	RW	Temperature Interrupt flag Temperature Update
28	<i>Reserved</i>	<i>To ensure compatibility with future devices, always write Reserved bits to their reset value, unless otherwise stated. More information in 1.2 Conventions</i>		
27	TEMPAVG	0x0	RW	Temperature Average Interrupt flag Averaged Temperature Update
26	<i>Reserved</i>	<i>To ensure compatibility with future devices, always write Reserved bits to their reset value, unless otherwise stated. More information in 1.2 Conventions</i>		
25	VSCALEDONE	0x0	RW	Vscale done Interrupt flag Voltage scaling completed. EM0 only.
24	EM23WAKEUP	0x0	RW	EM23 Wake up Interrupt flag EM23 wake up
23:18	<i>Reserved</i>	<i>To ensure compatibility with future devices, always write Reserved bits to their reset value, unless otherwise stated. More information in 1.2 Conventions</i>		
17	IOVDD0BOD	0x0	RW	VDDIO0 BOD Interrupt flag IOVDD0 BOD triggered
16	AVDDDBOD	0x0	RW	AVDD BOD Interrupt flag AVDD BOD triggered
15:0	<i>Reserved</i>	<i>To ensure compatibility with future devices, always write Reserved bits to their reset value, unless otherwise stated. More information in 1.2 Conventions</i>		

12.5.8 EMU_IEN - Interrupt Enables

Offset	Bit Position																																
0x068	31	30	29	28	27	26	25	24	23	22	21	20	19	18	17	16	15	14	13	12	11	10	9	8	7	6	5	4	3	2	1	0	
Reset	0x0	0x0	0x0		0x0		0x0	0x0							0x0	0x0																	
Access	RW	RW	RW		RW		RW	RW							RW	RW																	
Name	TEMPHIGH	TEMPLOW	TEMP		TEMPAVG		VSCALEDONE	EM23WAKEUP							IOVDD0BOD	AVDD0BOD																	

Bit	Name	Reset	Access	Description
31	TEMPHIGH	0x0	RW	Temperature high Interrupt enable Measured temperature above threshold Interrupt enable
30	TEMPLOW	0x0	RW	Temperature low Interrupt enable Measured temperature below threshold Interrupt enable
29	TEMP	0x0	RW	Temperature Interrupt enable Temperature Update Interrupt enable
28	<i>Reserved</i>	<i>To ensure compatibility with future devices, always write Reserved bits to their reset value, unless otherwise stated. More information in 1.2 Conventions</i>		
27	TEMPAVG	0x0	RW	Temperature Interrupt enable Averaged Temperature Interrupt enable
26	<i>Reserved</i>	<i>To ensure compatibility with future devices, always write Reserved bits to their reset value, unless otherwise stated. More information in 1.2 Conventions</i>		
25	VSCALEDONE	0x0	RW	Vscale done Interrupt enable Voltage scaling completed Interrupt enable. EM0 only.
24	EM23WAKEUP	0x0	RW	EM23 Wake up Interrupt enable EM23 wake up Interrupt enable
23:18	<i>Reserved</i>	<i>To ensure compatibility with future devices, always write Reserved bits to their reset value, unless otherwise stated. More information in 1.2 Conventions</i>		
17	IOVDD0BOD	0x0	RW	VDDIO0 BOD Interrupt enable IOVDD0 BOD Interrupt enable
16	AVDD0BOD	0x0	RW	AVDD BOD Interrupt enable AVDD BOD Interrupt enable
15:0	<i>Reserved</i>	<i>To ensure compatibility with future devices, always write Reserved bits to their reset value, unless otherwise stated. More information in 1.2 Conventions</i>		

12.5.9 EMU_EM4CTRL - EM4 Control

Offset	Bit Position																																																							
0x06C	31	30	29	28	27	26	25	24	23	22	21	20	19	18	17	16	15	14	13	12	11	10	9	8	7	6	5	4	3	2	1	0																								
Reset																								0x0			0x0																													0x0
Access																								RW			RW																													RW
Name																								BOD3SENSEEM4WU			EM4IORETMODE																													EM4ENTRY

Bit	Name	Reset	Access	Description
31:9	<i>Reserved</i>	<i>To ensure compatibility with future devices, always write Reserved bits to their reset value, unless otherwise stated. More information in 1.2 Conventions</i>		
8	BOD3SENSEEM4WU	0x0	RW	Set BOD3SENSE as EM4 wakeup Enable BOD3SENSE as EM4 wakeup source
7:6	<i>Reserved</i>	<i>To ensure compatibility with future devices, always write Reserved bits to their reset value, unless otherwise stated. More information in 1.2 Conventions</i>		
5:4	EM4IORETMODE	0x0	RW	EM4 IO retention mode Determine when IO retention will be applied and removed
	Value	Mode		Description
	0	DISABLE		No Retention: Pads enter reset state when entering EM4
	1	EM4EXIT		Retention through EM4: Pads enter reset state when exiting EM4
	2	SWUNLATCH		Retention through EM4 and Wakeup: software writes UNLATCH register to remove retention
3:2	<i>Reserved</i>	<i>To ensure compatibility with future devices, always write Reserved bits to their reset value, unless otherwise stated. More information in 1.2 Conventions</i>		
1:0	EM4ENTRY	0x0	RW	EM4 entry request This field is used to enter the Energy Mode 4 sequence. Writing the sequence 2,3,2,3,2,3,2 will enter the part into Energy Mode 4

12.5.10 EMU_CMD - EMU Command Register

Offset	Bit Position																																				
0x070	31	30	29	28	27	26	25	24	23	22	21	20	19	18	17	16	15	14	13	12	11	10	9	8	7	6	5	4	3	2	1	0					
Reset														0x0	0x0											0x0	0x0						0x0			0x0	
Access														W(nB)	W(nB)											W(nB)	W(nB)						W(nB)			W(nB)	
Name														TAMPERRCCLR	RSTCAUSECLR											EM01VSCALE2	EM01VSCALE1						TEMPAVGREQ			EM4UNLATCH	

Bit	Name	Reset	Access	Description
31:19	<i>Reserved</i>	<i>To ensure compatibility with future devices, always write Reserved bits to their reset value, unless otherwise stated. More information in 1.2 Conventions</i>		
18	TAMPERRCCLR	0x0	W(nB)	Tamper Reset Cause Clear Set this bit to clear the TAMPERRSTCAUSE register. Root access only
17	RSTCAUSECLR	0x0	W(nB)	Reset Cause Clear Set this bit to clear the RMURSTCAUSE register
16:12	<i>Reserved</i>	<i>To ensure compatibility with future devices, always write Reserved bits to their reset value, unless otherwise stated. More information in 1.2 Conventions</i>		
11	EM01VSCALE2	0x0	W(nB)	Scale voltage to Vscale2 EM01 Voltage Scale Command to scale to Voltage Scale Level 2
10	EM01VSCALE1	0x0	W(nB)	Scale voltage to Vscale1 EM01 Voltage Scale Command to scale to Voltage Scale Level 1
9:5	<i>Reserved</i>	<i>To ensure compatibility with future devices, always write Reserved bits to their reset value, unless otherwise stated. More information in 1.2 Conventions</i>		
4	TEMPAVGREQ	0x0	W(nB)	Temperature Average Request Request for Averaged Temperature Measurement
3:2	<i>Reserved</i>	<i>To ensure compatibility with future devices, always write Reserved bits to their reset value, unless otherwise stated. More information in 1.2 Conventions</i>		
1	EM4UNLATCH	0x0	W(nB)	EM4 unlatch GPIO unlatch request after EM4 wakeup. Only valid when EM4IORETMODE== SWUNLATCH
0	<i>Reserved</i>	<i>To ensure compatibility with future devices, always write Reserved bits to their reset value, unless otherwise stated. More information in 1.2 Conventions</i>		

12.5.11 EMU_CTRL - EMU Control Register

Offset	Bit Position																																									
0x074	31	30	29	28	27	26	25	24	23	22	21	20	19	18	17	16	15	14	13	12	11	10	9	8	7	6	5	4	3	2	1	0										
Reset	0x0	0x0	0x0														0x0														0x2							0x0				0x0
Access	RW	RW	RW														RW														RW							RW				RW
Name	EFPDRVDVDD	EFPDRVDECOUPLE	EFPDIRECTMODEEN														FLASHPWRUPONDEMAND														EM23VSCALE							TEMPAVGNUM				EM2DBGEN

Bit	Name	Reset	Access	Description
31	EFPDRVDVDD	0x0	RW	EFP drives DVDD EFP01 Drives DVDD. EFP IRQ is enabled on PC5. VREGVDD and DVDD pins should be shorted together on the PCB.
30	EFPDRVDECOUPLE	0x0	RW	EFP drives DECOUPLE EFP01 Drives DECOUPLE. Internal LDOs are disabled, EMU voltage scaling is done through EFP01, and EFP IRQ is enabled on PC5.
29	EFPDIRECTMODEEN	0x0	RW	EFP Direct Mode Enable EFP01 Direct mode enable. EMU drive I2C lines to transition EFP01 between energy modes. Firmware must use I2C1 module with SDA routed to PC1 and SCL routed to SC2.
28:17	Reserved	<i>To ensure compatibility with future devices, always write Reserved bits to their reset value, unless otherwise stated. More information in 1.2 Conventions</i>		
16	FLASHPWRUPONDEMAND	0x0	RW	Enable flash on demand wakeup When set, during wake up, Flash will be in power down mode until either incoming Flash data fetch or when software issue powerup command to IMEM->MSC_CMD register
15:10	Reserved	<i>To ensure compatibility with future devices, always write Reserved bits to their reset value, unless otherwise stated. More information in 1.2 Conventions</i>		
9:8	EM23VSCALE	0x2	RW	EM2/EM3 Vscale Set VSCALE value for EM2/EM3 mode
	Value	Mode	Description	
	0	VSCALE0	VSCALE0. 0.9v	
	1	VSCALE1	VSCALE1. 1.0v	
	2	VSCALE2	VSCALE2. 1.1v	
7:4	Reserved	<i>To ensure compatibility with future devices, always write Reserved bits to their reset value, unless otherwise stated. More information in 1.2 Conventions</i>		
3	TEMPAVGNUM	0x0	RW	Averaged Temperature samples num Number of samples taken for Averaged Temperature Measurement

Bit	Name	Reset	Access	Description
	Value	Mode		Description
	0	N16		16 measurements
	1	N64		64 measurements
2:1	<i>Reserved</i>	<i>To ensure compatibility with future devices, always write Reserved bits to their reset value, unless otherwise stated. More information in 1.2 Conventions</i>		
0	EM2DBGEN	0x0	RW	Enable debugging in EM2 Force debug power domain to stay on on EM2 entry. This allows debugger to remain connected in EM2.

12.5.12 EMU_TEMPLIMITS - EMU Temperature Thresholds

Offset	Bit Position																															
0x078	31	30	29	28	27	26	25	24	23	22	21	20	19	18	17	16	15	14	13	12	11	10	9	8	7	6	5	4	3	2	1	0
Reset									0x1FF																0x0							
Access									RW																RW							
Name									TEMPHIGH																TEMPLOW							

Bit	Name	Reset	Access	Description
31:25	<i>Reserved</i>	<i>To ensure compatibility with future devices, always write Reserved bits to their reset value, unless otherwise stated. More information in 1.2 Conventions</i>		
24:16	TEMPHIGH	0x1FF	RW	Temp High limit Temp threshold in degree Kelvin. The TEMPHIGH interrupt flag is set when a periodic temperature measurement is equal to or higher than this value.
15:9	<i>Reserved</i>	<i>To ensure compatibility with future devices, always write Reserved bits to their reset value, unless otherwise stated. More information in 1.2 Conventions</i>		
8:0	TEMPLOW	0x0	RW	Temp Low limit Temp threshold in degree Kelvin. The TEMPLOW interrupt flag is set when a periodic temperature measurement is equal to or lower than this value.

12.5.13 EMU_STATUS - EMU Status Register

Offset	Bit Position																																																					
0x084	31	30	29	28	27	26	25	24	23	22	21	20	19	18	17	16	15	14	13	12	11	10	9	8	7	6	5	4	3	2	1	0																						
Reset																							0x0	0x0	0x0	0x2	0x0	0x0	0x0	0x0	0x0	0x0																						
Access																							R	R	R	R	R	R	R	R	R	R	R	R	R	R	R	R	R	R	R	R	R	R	R	R	R	R	R	R	R	R	R	R
Name																							EM2ENTERED	EM4IORET	RACACTIVE	VSCALE	VSCALEFAILED	VSCALEBUSY	TEMPAVGACTIVE	TEMPACTIVE	FIRSTTEMPDONE	LOCK																						

Bit	Name	Reset	Access	Description
31:11	Reserved	To ensure compatibility with future devices, always write Reserved bits to their reset value, unless otherwise stated. More information in 1.2 Conventions		
10	EM2ENTERED	0x0	R	EM2 entered Confirm chip entered EM2 state. EM2 Entry request can be delayed or denied by peripherals.
9	EM4IORET	0x0	R	EM4 IO retention status The status of IO retention. Will be set upon EM4 entry based on EM4IORETMODE in EMU_EM4CTRL. Cleared by setting EM4UNLATCH in EMU_CMD
8	RACACTIVE	0x0	R	RAC active This bit indicates the status of the RAC state machine. System can not enter EM2 or lower if set.
7:6	VSCALE	0x2	R	Vscale status Current Voltage Scale Value
	Value	Mode		Description
	0	VSCALE0		Voltage scaling set to 0.9v
	1	VSCALE1		Voltage scaling set to 1.0v
	2	VSCALE2		Voltage scaling set to 1.1v
5	VSCALEFAILED	0x0	R	Vscale failed Voltage scaling failed. (Time out)
4	VSCALEBUSY	0x0	R	Vscale busy Voltage Scaling busy
3	TEMPAVGACTIVE	0x0	R	Temp Average active Average Temperature Measurement active
2	TEMPACTIVE	0x0	R	Temp active Temperature Measurement active
1	FIRSTTEMPDONE	0x0	R	First Temp done First Temperatue mesaurement completed
0	LOCK	0x0	R	Lock status Indicates the current status of EMU Lock

Bit	Name	Reset	Access	Description
	Value	Mode		Description
	0	UNLOCKED		All EMU lockable registers are unlocked.
	1	LOCKED		All EMU lockable registers are locked.

12.5.14 EMU_TEMP - Temperature

Offset	Bit Position																																	
	31	30	29	28	27	26	25	24	23	22	21	20	19	18	17	16	15	14	13	12	11	10	9	8	7	6	5	4	3	2	1	0		
0x088																																		
Reset											0x0															0x0							0x0	
Access											R															R							R	
Name											TEMPAVG															TEMP							TEMPLSB	

Bit	Name	Reset	Access	Description
31:27	Reserved	<i>To ensure compatibility with future devices, always write Reserved bits to their reset value, unless otherwise stated. More information in 1.2 Conventions</i>		
26:16	TEMPAVG	0x0	R	Averaged Temperature Averaged Temperature Measurement. Temperature in Kelvin. 9 integer bits and 2 decimal bits (0.25 Degree resolution)
15:11	Reserved	<i>To ensure compatibility with future devices, always write Reserved bits to their reset value, unless otherwise stated. More information in 1.2 Conventions</i>		
10:2	TEMP	0x0	R	Temperature measured Temperature in Kelvin. Value of last periodic temperature measurement. Value is asynchronously updated.
1:0	TEMPLSB	0x0	R	Temperature measured decimal part Temperature decimal part

12.5.15 EMU_RSTCTRL - Reset Management Control Register

Offset	Bit Position																																																						
0x090	31	30	29	28	27	26	25	24	23	22	21	20	19	18	17	16	15	14	13	12	11	10	9	8	7	6	5	4	3	2	1	0																							
Reset																						0x1			0x0	0x0			0x0	0x1																									0x1
Access																						RW			RW	RW				RW	RW																								RW
Name																						DECBODRMODE			IOVDD0BODRMODE	AVDDBODRMODE				LOCKUPRMODE	SYSRMODE																								WDOG0RMODE

Bit	Name	Reset	Access	Description
31:11	<i>Reserved</i>	<i>To ensure compatibility with future devices, always write Reserved bits to their reset value, unless otherwise stated. More information in 1.2 Conventions</i>		
10	DECBODRMODE	0x1	RW	Enable DECBOD reset LVBOD Reset Mode. DECOUPLE monitoring. BOD must be trimmed before it is used as a reset source.
	Value	Mode	Description	
	0	DISABLED	Reset request is blocked	
	1	ENABLED	The entire device is reset	
9:8	<i>Reserved</i>	<i>To ensure compatibility with future devices, always write Reserved bits to their reset value, unless otherwise stated. More information in 1.2 Conventions</i>		
7	IOVDD0BODRMODE	0x0	RW	Enable VDDIO0 BOD reset LEBOD2 Reset Mode. IOVDD0 monitoring. BOD must be trimmed before it is used as a reset source.
	Value	Mode	Description	
	0	DISABLED	Reset request is blocked	
	1	ENABLED	The entire device is reset except some EMU registers	
6	AVDDBODRMODE	0x0	RW	Enable AVDD BOD reset LEBOD1 Reset Mode. AVDD monitoring. BOD must be trimmed before it is used as a reset source.
	Value	Mode	Description	
	0	DISABLED	Reset Request is block	
	1	ENABLED	The entire device is reset except some EMU registers	
5:4	<i>Reserved</i>	<i>To ensure compatibility with future devices, always write Reserved bits to their reset value, unless otherwise stated. More information in 1.2 Conventions</i>		
3	LOCKUPRMODE	0x0	RW	Enable M33 Lockup reset Core LOCKUP Reset Mode
	Value	Mode	Description	
	0	DISABLED	Reset Request is Block	

Bit	Name	Reset	Access	Description
	1	ENABLED		The entire device is reset except some EMU registers
2	SYSRMODE	0x1	RW	Enable M33 System reset Core Sysreset Reset Mode
	Value	Mode		Description
	0	DISABLED		Reset request is blocked
	1	ENABLED		Device is reset except some EMU registers
1	<i>Reserved</i>	<i>To ensure compatibility with future devices, always write Reserved bits to their reset value, unless otherwise stated. More information in 1.2 Conventions</i>		
0	WDOG0RMODE	0x1	RW	Enable WDOG0 reset WDOG0 Reset Mode
	Value	Mode		Description
	0	DISABLED		Reset request is blocked
	1	ENABLED		The entire device is reset except some EMU registers

12.5.16 EMU_RSTCAUSE - Reset Cause

Offset	Bit Position																																
0x094	31	30	29	28	27	26	25	24	23	22	21	20	19	18	17	16	15	14	13	12	11	10	9	8	7	6	5	4	3	2	1	0	
Reset	0x0																			0x0		0x0	0x0	0x0	0x0	0x0	0x0	0x0	0x0	0x0	0x0	0x0	0x0
Access	R																			R		R	R	R	R	R	R	R	R	R	R	R	R
Name	VREGIN																			SETAMPER		IOVDD0BOD	AVDDBOD	DECBOD	DVDDLEBOD	DVddbOD	SYSREQ	LOCKUP	WDOG1	WDOG0	EM4	PIN	POR

Bit	Name	Reset	Access	Description
31	VREGIN	0x0	R	DCDC VREGIN comparator DCDC VREGIN comparator below threshold. For Information only, not a direct source for reset. Should be used to determine whether the previous reset was caused by DCDC input being too low to support current load. In this case it is advised to keep the chip in BYPASS mode and check battery level before re-enabling integrated DCDC
30:14	<i>Reserved</i>			<i>To ensure compatibility with future devices, always write Reserved bits to their reset value, unless otherwise stated. More information in 1.2 Conventions</i>
13	SETAMPER	0x0	R	SE Tamper event Reset Last reset was a SE Tamper event reset
12	<i>Reserved</i>			<i>To ensure compatibility with future devices, always write Reserved bits to their reset value, unless otherwise stated. More information in 1.2 Conventions</i>
11	IOVDD0BOD	0x0	R	LEBOD2 Reset Brown Out Detector monitoring IOVDD0
10	AVDDBOD	0x0	R	LEBOD1 Reset Brown Out Detector monitoring AVDD
9	DECBOD	0x0	R	LVBOD Reset Brown Out Detector monitoring DECOUPLE
8	DVDDLEBOD	0x0	R	LEBOD Reset Brown Out Detector monitoring DVDD in EM2/3
7	DVddbOD	0x0	R	HVBOD Reset Brown Out Detector monitoring DVDD in EM0/1
6	SYSREQ	0x0	R	M33 Core Sys Reset Last Reset was as M33 Core System reset
5	LOCKUP	0x0	R	M33 Core Lockup Reset Last Reset was as M33 Core Lockup reset
4	WDOG1	0x0	R	Watchdog 1 Reset Last reset was a Watchdog 1 reset
3	WDOG0	0x0	R	Watchdog 0 Reset Last reset was a Watchdog 0 reset
2	EM4	0x0	R	EM4 Wakeup Reset

Bit	Name	Reset	Access	Description
				Last reset was a EM4 Wakeup
1	PIN	0x0	R	Pin Reset Last reset was a Pin reset
0	POR	0x0	R	Power On Reset Last reset was a Power On Reset

12.5.17 EMU_TAMPERRSTCAUSE - Tamper Reset Cause

Offset	Bit Position																																
0x098	31	30	29	28	27	26	25	24	23	22	21	20	19	18	17	16	15	14	13	12	11	10	9	8	7	6	5	4	3	2	1	0	
Reset																	0x0																
Access																	R																
Name																	TAMPERRST																

Bit	Name	Reset	Access	Description
31:0	TAMPERRST	0x0	R	Tamper reset vector Tamper reset vector. Reset cause indicator defining which tamper response index triggered the previous tamper reset. Cleared with TAMPERRCCLR

12.5.18 EMU_DGIF - Interrupt Flags Debug

Offset	Bit Position																																
0x0A0	31	30	29	28	27	26	25	24	23	22	21	20	19	18	17	16	15	14	13	12	11	10	9	8	7	6	5	4	3	2	1	0	
Reset	0x0	0x0	0x0					0x0																									
Access	RW	RW	RW					RW																									
Name	TEMPHIGHDGIF	TEMPLOWDGIF	TEMPDGIF					EM23WAKEUPDGIF																									

Bit	Name	Reset	Access	Description
31	TEMPHIGHDGIF	0x0	RW	Temperature high Interrupt flag Measured temperature above threshold
30	TEMPLOWDGIF	0x0	RW	Temperature low Interrupt flag Measured temperature below threshold
29	TEMPDGIF	0x0	RW	Temperature Interrupt flag Temperature Update
28:25	<i>Reserved</i>	<i>To ensure compatibility with future devices, always write Reserved bits to their reset value, unless otherwise stated. More information in 1.2 Conventions</i>		
24	EM23WAKEUPDGIF	0x0	RW	EM23 Wake up Interrupt flag EM23 wake up
23:0	<i>Reserved</i>	<i>To ensure compatibility with future devices, always write Reserved bits to their reset value, unless otherwise stated. More information in 1.2 Conventions</i>		

12.5.19 EMU_DGIEN - Interrupt Enables Debug

Offset	Bit Position																																
0x0A4	31	30	29	28	27	26	25	24	23	22	21	20	19	18	17	16	15	14	13	12	11	10	9	8	7	6	5	4	3	2	1	0	
Reset	0x0	0x0	0x0					0x0																									
Access	RW	RW	RW					RW																									
Name	TEMPHIGHDGIEN	TEMPLOWDGIEN	TEMPDGIEN					EM23WAKEUPDGIEN																									

Bit	Name	Reset	Access	Description
31	TEMPHIGHDGIEN	0x0	RW	Temperature high Interrupt enable Measured temperature above threshold
30	TEMPLOWDGIEN	0x0	RW	Temperature low Interrupt enable Measured temperature below threshold
29	TEMPDGIEN	0x0	RW	Temperature Interrupt enable Temperature Update
28:25	<i>Reserved</i>	<i>To ensure compatibility with future devices, always write Reserved bits to their reset value, unless otherwise stated. More information in 1.2 Conventions</i>		
24	EM23WAKEUPDGIEN	0x0	RW	EM23 Wake up Interrupt enable EM23 wake up
23:0	<i>Reserved</i>	<i>To ensure compatibility with future devices, always write Reserved bits to their reset value, unless otherwise stated. More information in 1.2 Conventions</i>		

12.5.20 EMU_EFPIF - EFP Interrupt Register

Offset	Bit Position																															
0x100	31	30	29	28	27	26	25	24	23	22	21	20	19	18	17	16	15	14	13	12	11	10	9	8	7	6	5	4	3	2	1	0
Reset																																0x0
Access																																RW
Name																																EFPIF

Bit	Name	Reset	Access	Description
31:1	<i>Reserved</i>	<i>To ensure compatibility with future devices, always write Reserved bits to their reset value, unless otherwise stated. More information in 1.2 Conventions</i>		
0	EFPIF	0x0	RW	EFP Interrupt Flag EFP Interrupt

12.5.21 EMU_EFPIEN - EFP Interrupt Enable Register

Offset	Bit Position																															
0x104	31	30	29	28	27	26	25	24	23	22	21	20	19	18	17	16	15	14	13	12	11	10	9	8	7	6	5	4	3	2	1	0
Reset																																0x0
Access																																RW
Name																																EFPIEN

Bit	Name	Reset	Access	Description
31:1	Reserved	To ensure compatibility with future devices, always write Reserved bits to their reset value, unless otherwise stated. More information in 1.2 Conventions		
0	EFPIEN Enable EFP Interrupt	0x0	RW	EFP Interrupt enable

12.6 DCDC Register Map

The offset register address is relative to the registers base address.

Offset	Name	Type	Description
0x000	DCDC_IPVERSION	R	IPVERSION
0x004	DCDC_CTRL	RW SYNC	Control
0x008	DCDC_EM01CTRL0	RW SYNC	EM01 Control
0x010	DCDC_EM23CTRL0	RW SYNC	EM23 Control
0x020	DCDC_PFMXCTRL	RW SYNC	PFMX Control Register
0x028	DCDC_IF	RWH INTFLAG	Interrupt Flags
0x02C	DCDC_IEN	RW	Interrupt Enable
0x030	DCDC_STATUS	RH	Status Register
0x034	DCDC_SYNCBUSY	RH	Syncbusy Status Register
0x040	DCDC_LOCK	W	Lock Register
0x044	DCDC_LOCKSTATUS	RH	Lock Status Register
0x1000	DCDC_IPVERSION_SET	R	IPVERSION
0x1004	DCDC_CTRL_SET	RW SYNC	Control
0x1008	DCDC_EM01CTRL0_SET	RW SYNC	EM01 Control
0x1010	DCDC_EM23CTRL0_SET	RW SYNC	EM23 Control
0x1020	DCDC_PFMXCTRL_SET	RW SYNC	PFMX Control Register
0x1028	DCDC_IF_SET	RWH INTFLAG	Interrupt Flags
0x102C	DCDC_IEN_SET	RW	Interrupt Enable
0x1030	DCDC_STATUS_SET	RH	Status Register
0x1034	DCDC_SYNCBUSY_SET	RH	Syncbusy Status Register
0x1040	DCDC_LOCK_SET	W	Lock Register
0x1044	DCDC_LOCKSTATUS_SET	RH	Lock Status Register
0x2000	DCDC_IPVERSION_CLR	R	IPVERSION
0x2004	DCDC_CTRL_CLR	RW SYNC	Control
0x2008	DCDC_EM01CTRL0_CLR	RW SYNC	EM01 Control
0x2010	DCDC_EM23CTRL0_CLR	RW SYNC	EM23 Control
0x2020	DCDC_PFMXCTRL_CLR	RW SYNC	PFMX Control Register
0x2028	DCDC_IF_CLR	RWH INTFLAG	Interrupt Flags
0x202C	DCDC_IEN_CLR	RW	Interrupt Enable
0x2030	DCDC_STATUS_CLR	RH	Status Register
0x2034	DCDC_SYNCBUSY_CLR	RH	Syncbusy Status Register
0x2040	DCDC_LOCK_CLR	W	Lock Register
0x2044	DCDC_LOCKSTATUS_CLR	RH	Lock Status Register
0x3000	DCDC_IPVERSION_TGL	R	IPVERSION
0x3004	DCDC_CTRL_TGL	RW SYNC	Control

Offset	Name	Type	Description
0x3008	DCDC_EM01CTRL0_TGL	RW SYNC	EM01 Control
0x3010	DCDC_EM23CTRL0_TGL	RW SYNC	EM23 Control
0x3020	DCDC_PFMXCTRL_TGL	RW SYNC	PFMX Control Register
0x3028	DCDC_IF_TGL	RWH INTFLAG	Interrupt Flags
0x302C	DCDC_IEN_TGL	RW	Interrupt Enable
0x3030	DCDC_STATUS_TGL	RH	Status Register
0x3034	DCDC_SYNCBUSY_TGL	RH	Syncbusy Status Register
0x3040	DCDC_LOCK_TGL	W	Lock Register
0x3044	DCDC_LOCKSTATUS_TGL	RH	Lock Status Register

12.7 DCDC Register Description

12.7.1 DCDC_IPVERSION - IPVERSION

Offset	Bit Position																															
0x000	31	30	29	28	27	26	25	24	23	22	21	20	19	18	17	16	15	14	13	12	11	10	9	8	7	6	5	4	3	2	1	0
Reset																0x2																
Access																R																
Name																IPVERSION																

Bit	Name	Reset	Access	Description
31:0	IPVERSION IPVERSION number	0x2	R	IPVERSION

12.7.2 DCDC_CTRL - Control

Offset	Bit Position																															
0x004	31	30	29	28	27	26	25	24	23	22	21	20	19	18	17	16	15	14	13	12	11	10	9	8	7	6	5	4	3	2	1	0
Reset																									0x10						0x0	
Access																									RW						RW	
Name																									IPKTMAXCTRL						MODE	

Bit	Name	Reset	Access	Description									
31:9	Reserved	To ensure compatibility with future devices, always write Reserved bits to their reset value, unless otherwise stated. More information in 1.2 Conventions											
8:4	IPKTMAXCTRL	0x10	RW	<p>Ton_max timeout control</p> <p>Ton_max = (ipk_tmax_ctrl + 1)*0.07us; specifies the timeout duration when attempting to hit programmed peak current; TMAX interrupt flag gives user information whether timeout was hit before reaching peak current</p>									
3:1	Reserved	To ensure compatibility with future devices, always write Reserved bits to their reset value, unless otherwise stated. More information in 1.2 Conventions											
0	MODE	0x0	RW	<p>DCDC/Bypass Mode Control</p> <p>Used to switch between bypass and dcdc regulation, this triggers a sequence of controls. IF/STATUS registers can be used to check the true status of DCDC regulator/bypass switch</p> <table border="1"> <thead> <tr> <th>Value</th> <th>Mode</th> <th>Description</th> </tr> </thead> <tbody> <tr> <td>0</td> <td>BYPASS</td> <td>DCDC is OFF, bypass switch is enabled</td> </tr> <tr> <td>1</td> <td>DCDCREGULATION</td> <td>Request DCDC regulation, bypass switch disabled</td> </tr> </tbody> </table>	Value	Mode	Description	0	BYPASS	DCDC is OFF, bypass switch is enabled	1	DCDCREGULATION	Request DCDC regulation, bypass switch disabled
Value	Mode	Description											
0	BYPASS	DCDC is OFF, bypass switch is enabled											
1	DCDCREGULATION	Request DCDC regulation, bypass switch disabled											

12.7.3 DCDC_EM01CTRL0 - EM01 Control

Offset	Bit Position																																	
0x008	31	30	29	28	27	26	25	24	23	22	21	20	19	18	17	16	15	14	13	12	11	10	9	8	7	6	5	4	3	2	1	0		
Reset																							0x1							0x9				
Access																							RW							RW				
Name																							DRVSPEED							IPKVAL				

Bit	Name	Reset	Access	Description
31:10	<i>Reserved</i>	<i>To ensure compatibility with future devices, always write Reserved bits to their reset value, unless otherwise stated. More information in 1.2 Conventions</i>		
9:8	DRVSPEED	0x1	RW	EM01 Drive Speed Setting Used to configure drive speed for tradeoff between EMI and Efficiency
	Value	Mode	Description	
	0	BEST_EMI	Not recommended for use (no benefit to this setting)	
	1	DEFAULT_SETTING	Recommended for use for best efficiency and low EMI	
	2	INTERMEDIATE	Not recommended for use (no benefit to this setting)	
	3	BEST_EFFICIENCY	Not recommended for use (no benefit to this setting)	
7:4	<i>Reserved</i>	<i>To ensure compatibility with future devices, always write Reserved bits to their reset value, unless otherwise stated. More information in 1.2 Conventions</i>		
3:0	IPKVAL	0x9	RW	EM01 Peak Current Setting Used to configure for required peak/load current in EM01; Max load current is approximately 0.4*Ipk
	Value	Mode	Description	
	3	LOAD36MA	Ipeak = 90mA, Iload = 36mA	
	4	LOAD40MA	Ipeak = 100mA, Iload = 40mA	
	5	LOAD44MA	Ipeak = 110mA, Iload = 44mA	
	6	LOAD48MA	Ipeak = 120mA, Iload = 48mA	
	7	LOAD52MA	Ipeak = 130mA, Iload = 52mA	
	8	LOAD56MA	Ipeak = 140mA, Iload = 56mA	
	9	LOAD60MA	Ipeak = 150mA, Iload = 60mA	

12.7.4 DCDC_EM23CTRL0 - EM23 Control

Offset	Bit Position																															
0x010	31	30	29	28	27	26	25	24	23	22	21	20	19	18	17	16	15	14	13	12	11	10	9	8	7	6	5	4	3	2	1	0
Reset																								0x1					0x3			
Access																								RW					RW			
Name																								DRVSPEED					IPKVAL			

Bit	Name	Reset	Access	Description
31:10	<i>Reserved</i>	<i>To ensure compatibility with future devices, always write Reserved bits to their reset value, unless otherwise stated. More information in 1.2 Conventions</i>		
9:8	DRVSPEED	0x1	RW	EM23 Drive Speed Setting Used to configure drive speed for tradeoff between EMI and Efficiency
	Value	Mode		Description
	0	BEST_EMI		Not recommended for use (no benefit to this setting)
	1	DEFAULT_SETTING		Recommended for use for best efficiency and low EMI
	2	INTERMEDIATE		Not recommended for use (no benefit to this setting)
	3	BEST_EFFICIENCY		Not recommended for use (no benefit to this setting)
7:4	<i>Reserved</i>	<i>To ensure compatibility with future devices, always write Reserved bits to their reset value, unless otherwise stated. More information in 1.2 Conventions</i>		
3:0	IPKVAL	0x3	RW	EM23 Peak Current Setting Used to configure for required peak/load current in EM23
	Value	Mode		Description
	3	LOAD5MA		I _{peak} = 90mA, I _{load} = 5 mA
	9	LOAD10MA		I _{peak} = 150mA, I _{load} = 10 mA

12.7.5 DCDC_PFMXCTRL - PFMX Control Register

Offset	Bit Position																															
0x020	31	30	29	28	27	26	25	24	23	22	21	20	19	18	17	16	15	14	13	12	11	10	9	8	7	6	5	4	3	2	1	0
Reset																	0xC												0xC			
Access																	RW												RW			
Name																	IPKTMXCTRL												IPKVAL			

Bit	Name	Reset	Access	Description
31:13	<i>Reserved</i>	<i>To ensure compatibility with future devices, always write Reserved bits to their reset value, unless otherwise stated. More information in 1.2 Conventions</i>		
12:8	IPKTMXCTRL	0xC	RW	Ton_max timeout control
7:4	<i>Reserved</i>	<i>To ensure compatibility with future devices, always write Reserved bits to their reset value, unless otherwise stated. More information in 1.2 Conventions</i>		
3:0	IPKVAL	0xC	RW	PFMX mode Peak Current Setting Used to configure for required peak/load current in PFMX mode
	Value	Mode	Description	
	3	LOAD50MA	Ipeak = 90 mA, Iload = 50 mA	
	4	LOAD65MA	Ipeak = 100 mA, Iload = 65 mA	
	5	LOAD73MA	Ipeak = 110 mA, Iload = 73 mA	
	6	LOAD80MA	Ipeak = 120 mA, Iload = 80 mA	
	7	LOAD86MA	Ipeak = 130 mA, Iload = 86 mA	
	8	LOAD93MA	Ipeak = 140 mA, Iload = 93 mA	
	9	LOAD100MA	Ipeak = 150 mA, Iload = 100 mA	
	10	LOAD106MA	Ipeak = 160 mA, Iload = 106 mA	
	11	LOAD113MA	Ipeak = 170 mA, Iload = 113 mA	
	12	LOAD120MA	Ipeak = 180 mA, Iload = 120 mA	

12.7.6 DCDC_IF - Interrupt Flags

Offset	Bit Position																																																					
0x028	31	30	29	28	27	26	25	24	23	22	21	20	19	18	17	16	15	14	13	12	11	10	9	8	7	6	5	4	3	2	1	0																						
Reset																							RW	0x0			0x0		0x0		0x0		0x0		0x0		0x0		0x0		0x0		0x0		0x0		0x0		0x0		0x0		0x0	
Access																							RW				RW		RW		RW		RW		RW		RW		RW		RW		RW		RW		RW		RW		RW		RW	
Name																							PFMXMODE				EM4ERR		TMAX		REGULATION		VREGINHIGH		VREGINLOW		RUNNING		WARM		BYP SW													

Bit	Name	Reset	Access	Description
31:10	Reserved	To ensure compatibility with future devices, always write Reserved bits to their reset value, unless otherwise stated. More information in 1.2 Conventions		
9	PFMXMODE	0x0	RW	Entered PFMX mode Entered PFMX mode
8	Reserved	To ensure compatibility with future devices, always write Reserved bits to their reset value, unless otherwise stated. More information in 1.2 Conventions		
7	EM4ERR	0x0	RW	EM4 Entry Request Error EM4 entry error - software requesting EM4 entry when bypass switch is disabled
6	TMAX	0x0	RW	Ton_max Timeout Reached Ton_max timeout was reached before peak current could be achieved
5	REGULATION	0x0	RW	DCDC in regulation DCDC in regulation, output voltage is in range of target voltage
4	VREGINHIGH	0x0	RW	VREGIN above threshold VREGIN/VBAT above threshold
3	VREGINLOW	0x0	RW	VREGIN below threshold VREGIN/VBAT below threshold
2	RUNNING	0x0	RW	DCDC Running biasen, vcmpen, buckmodeen=1, bypass switch has been turned off.. Note that DCDC might not be in regulation yet. ie output voltage may not be in range of target voltage
1	WARM	0x0	RW	DCDC Warmup Time Done 100us DCDC warmup time since biasen=1 and dcdvcmpen=1 complete
0	BYP SW	0x0	RW	Bypass Switch Enabled Bypass Switch Enabled

12.7.7 DCDC_IEN - Interrupt Enable

Offset	Bit Position																																																					
0x02C	31	30	29	28	27	26	25	24	23	22	21	20	19	18	17	16	15	14	13	12	11	10	9	8	7	6	5	4	3	2	1	0																						
Reset																							RW	0x0			RW	0x0	RW	0x0	RW	0x0	RW	0x0	RW	0x0	RW	0x0	RW	0x0	RW	0x0	RW	0x0	RW	0x0	RW	0x0	RW	0x0	RW	0x0	RW	0x0
Access																							RW				RW		RW		RW		RW		RW		RW		RW		RW		RW		RW		RW		RW		RW		RW	
Name																							PFMXMODE				EM4ERR		TMAX		REGULATION		VREGINHIGH		VREGINLOW		RUNNING		WARM		BYP SW													

Bit	Name	Reset	Access	Description
31:10	<i>Reserved</i>	<i>To ensure compatibility with future devices, always write Reserved bits to their reset value, unless otherwise stated. More information in 1.2 Conventions</i>		
9	PFMXMODE PFMX Mode Interrupt Enable	0x0	RW	PFMX Mode Interrupt Enable
8	<i>Reserved</i>	<i>To ensure compatibility with future devices, always write Reserved bits to their reset value, unless otherwise stated. More information in 1.2 Conventions</i>		
7	EM4ERR EM4 Entry Request Error Interrupt Enable	0x0	RW	EM4 Entry Req Interrupt Enable
6	TMAX Ton_max Timeout Interrupt Enable	0x0	RW	Ton_max Timeout Interrupt Enable
5	REGULATION DCDC in Regulation Interrupt Enable	0x0	RW	DCDC in Regulation Interrupt Enable
4	VREGINHIGH VREGIN above threshold Interrupt Enable	0x0	RW	VREGIN above threshold Interrupt Enable
3	VREGINLOW VREGIN below threshold Interrupt Enable	0x0	RW	VREGIN below threshold Interrupt Enable
2	RUNNING DCDC Running Interrupt Enable	0x0	RW	DCDC Running Interrupt Enable
1	WARM DCDC Warmup Time Done Interrupt Enable	0x0	RW	DCDC Warmup Time Done Interrupt Enable
0	BYP SW Bypass Switch Enabled Interrupt Enable	0x0	RW	Bypass Switch Enabled Interrupt Enable

12.7.8 DCDC_STATUS - Status Register

Offset	Bit Position																																																			
0x030	31	30	29	28	27	26	25	24	23	22	21	20	19	18	17	16	15	14	13	12	11	10	9	8	7	6	5	4	3	2	1	0																				
Reset																							0x0																				0x0					0x0	0x0	0x0	0x0	0x0
Access																							R																				R					R	R	R	R	R
Name																							PFMXMODE																									BYPCMPOUT	VREGIN	RUNNING	WARM	BYPSW

Bit	Name	Reset	Access	Description
31:10	<i>Reserved</i>	<i>To ensure compatibility with future devices, always write Reserved bits to their reset value, unless otherwise stated. More information in 1.2 Conventions</i>		
9	PFMXMODE DCDC in pfm mode	0x0	R	DCDC in PFMX mode
8:5	<i>Reserved</i>	<i>To ensure compatibility with future devices, always write Reserved bits to their reset value, unless otherwise stated. More information in 1.2 Conventions</i>		
4	BYPCMPOUT Bypass Comparator Output	0x0	R	Bypass Comparator Output
3	VREGIN 0: VREGVDD above threshold, 1: VREGVDD below threshold	0x0	R	VREGVDD comparator status
2	RUNNING DCDC is running (buckmodeen=1, dcdvcmpen=1, biasen=1, bypsw=0)	0x0	R	DCDC is running
1	WARM 100us DCDC warmup time since biasen=1 and dcdvcmpen=1 complete	0x0	R	DCDC Warmup Done
0	BYPSW Bypass switch is currently enabled	0x0	R	Bypass Switch is currently enabled

12.7.9 DCDC_SYNCBUSY - Syncbusy Status Register

Offset	Bit Position																																																							
0x034	31	30	29	28	27	26	25	24	23	22	21	20	19	18	17	16	15	14	13	12	11	10	9	8	7	6	5	4	3	2	1	0																								
Reset																								0x0				0x0	0x0	0x0	0x0																									
Access																								R																																
Name																								PFMXCTRL																																

Bit	Name	Reset	Access	Description
31:8	<i>Reserved</i>	<i>To ensure compatibility with future devices, always write Reserved bits to their reset value, unless otherwise stated. More information in 1.2 Conventions</i>		
7	PFMXCTRL PFMXCTRL Sync Busy Status	0x0	R	PFMXCTRL Sync Busy Status
6:4	<i>Reserved</i>	<i>To ensure compatibility with future devices, always write Reserved bits to their reset value, unless otherwise stated. More information in 1.2 Conventions</i>		
3	EM23CTRL0 EM23CTRL0 Sync Busy Status	0x0	R	EM23CTRL0 Sync Busy Status
2	EM01CTRL1 EM01CTRL1 Sync Bust Status	0x0	R	EM01CTRL1 Sync Bust Status
1	EM01CTRL0 EM01CTRL0 Sync Busy Status	0x0	R	EM01CTRL0 Sync Busy Status
0	CTRL CTRL Sync Busy Status	0x0	R	CTRL Sync Busy Status

12.7.10 DCDC_LOCK - Lock Register

Offset	Bit Position																															
0x040	31	30	29	28	27	26	25	24	23	22	21	20	19	18	17	16	15	14	13	12	11	10	9	8	7	6	5	4	3	2	1	0
Reset																	0x0															
Access																	W															
Name																	LOCKKEY															

Bit	Name	Reset	Access	Description
31:16	Reserved	To ensure compatibility with future devices, always write Reserved bits to their reset value, unless otherwise stated. More information in 1.2 Conventions		
15:0	LOCKKEY	0x0	W	Configuration Lock Key Write any other value than the unlock code to lock all DCDC registers
	Value	Mode	Description	
	43981	UNLOCKKEY		

12.7.11 DCDC_LOCKSTATUS - Lock Status Register

Offset	Bit Position																															
0x044	31	30	29	28	27	26	25	24	23	22	21	20	19	18	17	16	15	14	13	12	11	10	9	8	7	6	5	4	3	2	1	0
Reset																																0x0
Access																																R
Name																																LOCK

Bit	Name	Reset	Access	Description
31:1	Reserved	To ensure compatibility with future devices, always write Reserved bits to their reset value, unless otherwise stated. More information in 1.2 Conventions		
0	LOCK	0x0	R	Lock Status Lock Status Read-Only Register
	Value	Mode	Description	
	0	UNLOCKED	Unlocked State	
	1	LOCKED	LOCKED STATE	

13. PRS - Peripheral Reflex System

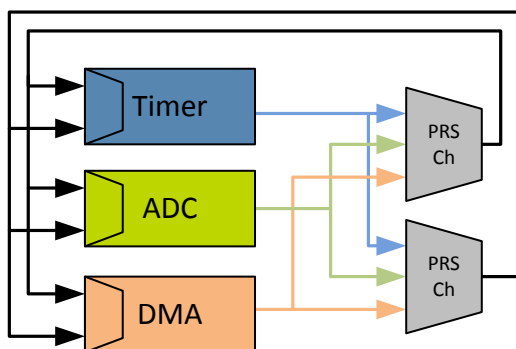
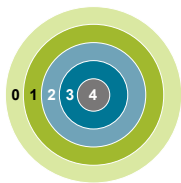

Quick Facts

What?

The PRS (Peripheral Reflex System) allows configurable, fast, and autonomous communication between peripherals.

Why?

Events and signals from one peripheral can be used as input signals to trigger actions in other peripherals. PRS reduces latency and ensures predictable timing by reducing software overhead and thus current consumption.

How?

Without CPU intervention the peripherals can send reflex signals to each other in single- or chained steps. The peripherals can be set up to perform actions based on the incoming reflex signals. This results in improved system performance and reduced energy consumption.

13.1 Introduction

The Peripheral Reflex System is a signal routing network allowing direct communication between different peripheral modules without involving the CPU. Peripheral modules which send out reflex signals to the PRS are called producers, and modules accepting reflex signals are called consumers. The PRS routes the reflex signals from producer to consumer peripherals, which perform actions depending on the reflex signals received.

13.2 Features

16 configurable asynchronous channels

- Each channel can be connected to any producer
- Consumers can be configured to listen to any asynchronous channel
- Can generate events to the CPU and the DMA
- Software controlled channel output using the SWPULSE and SWLEVEL registers
- Configurable logic to implement combinational functions between channels; multiple channels may be cascaded to produce more complex functions

4 configurable synchronous channels

- Special set of channels for high speed signalling between IADC and TIMER blocks

13.3 Functional Description

The PRS contains 16 asynchronous and 4 synchronous reflex channels. An overview of an asynchronous PRS reflex channel is shown in [Figure 13.1 PRS Asynchronous Channel Overview on page 347](#). Synchronous channels are similar but do not include the configurable logic block or SWLEVEL / SWPULSE features. Asynchronous channels can be connected to any signal offered by the producers while the synchronous channels are restricted to special signals from the TIMER, IADC, and VDAC modules.

Similarly on the consumer side, all the peripherals can listen to asynchronous channels while only the TIMER, IADC, and VDAC modules can listen to synchronous channels. The consumers of a channel (synchronous or asynchronous) can choose which PRS channel to listen to and perform actions based on the reflex signals routed through that channel. Synchronous channels are only available in EM0 and EM1 while asynchronous channels are available in EM0, EM1, EM2 and EM3.

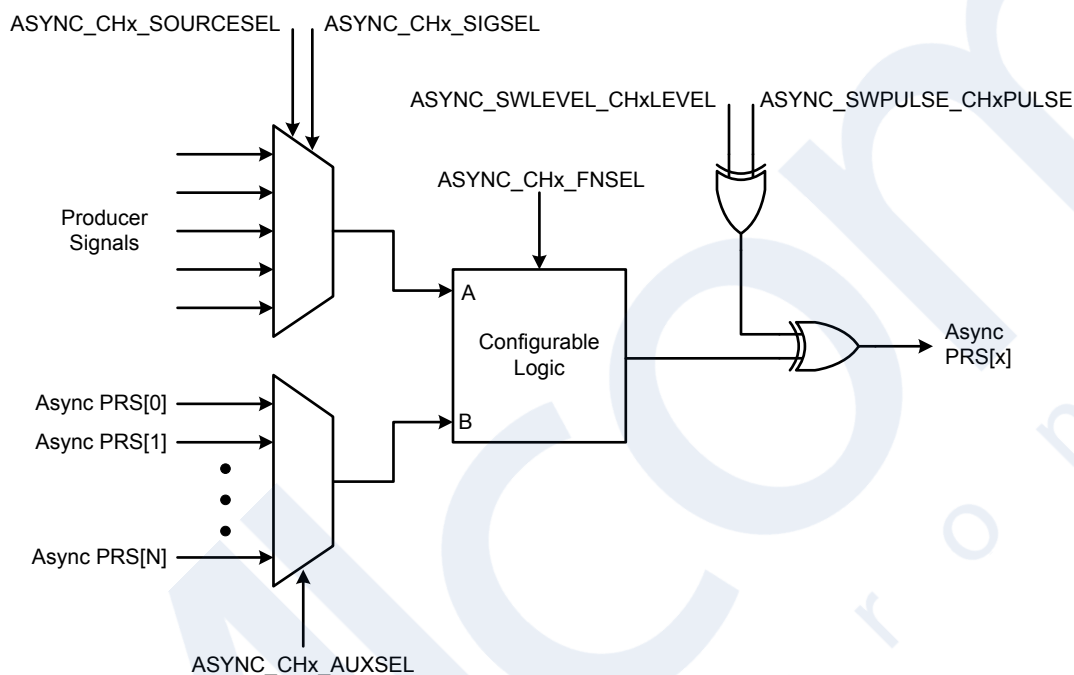

Figure 13.1. PRS Asynchronous Channel Overview

13.3.1 Asynchronous Channel Functions

Different functions can be applied to a reflex signal within the PRS. The asynchronous PRS channels can be manually triggered by writing to PRS_ASYNC_SWPULSE or PRS_ASYNC_SWLEVEL. SWLEVEL[n] is a programmable level for each asynchronous channel and holds the value it is programmed to. Setting SWPULSE[n] will cause the asynchronous channel to output a high pulse that is one EM01GRPACLK clock cycle wide. The SWLEVEL[n] and SWPULSE[n] signals are then XOR'ed with the output from the configurable logic block to form the output signal and is sent to the channel selection logic for every consumer signal. For example, when SWLEVEL[n] is set, if configurable logic produces a signal of 1, this will cause a channel output of 0.

13.3.2 Configurable Logic

The configurable logic feature enables a PRS channel to perform logic operations on the signal coming from the selected producer. Every asynchronous channel has a configurable logic block that can be programmed using the FNSSEL field in the asynchronous channel control register. The configurable logic block for each channel has two inputs. Input A is the signal from the selected producer determined by SOURCESEL and SIGSEL of PRS_ASYNCn_CTRL. Input B may be selected from the output of any other asynchronous PRS channel using the ASYNC_CHx_AUXSEL field. This allows for more complex logic functions to be created using multiple PRS channels.

Table 13.1. Configurable Logic Look up Table

A	B	FNSSEL
0	0	FNSSEL[0]
0	1	FNSSEL[1]
1	0	FNSSEL[2]
1	1	FNSSEL[3]

The configurable logic feature is implemented as a 2 input look up table, with each bit of FNSSEL representing the outcome for a specific input combination (see [Table 13.1 Configurable Logic Look up Table on page 348](#)). For example, if input A is 0 and input B is 1, then the PRS output will assume the value of bit 1 of FNSSEL (FNSSEL[1]).

To calculate the FNSSEL field for an "A NAND B" function, the truth table can be filled out as:

Table 13.2. A NAND B Example

A	B	FNSSEL = (A NAND B)
0	0	FNSSEL[0] = 1
0	1	FNSSEL[1] = 1
1	0	FNSSEL[2] = 1
1	1	FNSSEL[3] = 0

In this example, the value of FNSSEL has been calculated to be 0111 (binary), or 0x7.

Using the FNSSEL field, a total of 16 two-input logic functions can be implemented, as shown in [Table 13.3 List of Logic Functions on page 348](#).

Table 13.3. List of Logic Functions

FNSSEL value	Implemented Function
0x0	0
0x1	A NOR B
0x2	(NOT A) AND B
0x3	NOT A
0x4	A AND (NOT B)
0x5	(NOT B)
0x6	A XOR B
0x7	A NAND B
0x8	A AND B
0x9	A XNOR B

FNSEL value	Implemented Function
0xA	B
0xB	(NOT A) OR B
0xC	A
0xD	A OR (NOT B)
0xE	A OR B
0xF	1

The default value of FNSSEL is 0xC, meaning that the input from the selected producer goes through unchanged. This feature can be used to combine multiple channels to get even more complex functions.

13.3.3 Producers

Through SOURCESEL in PRS_SYNCHx_CTRL or PRS_ASYNCx_CTRL, each PRS channel (synchronous and asynchronous respectively) selects its signal producers. Each producer outputs one or more signals which can be selected by setting the SIGSEL field. Setting the SOURCESEL bits to 0 (Off) leads to a constant 0 output from the input mux regardless of SIGSEL.

The GPIO producer signals depend on settings in the GPIO module. They are selected using the edge interrupt configuration settings described in [24.3.10.1 Standard Interrupt Generation](#). PIN0 uses settings for the EXTI0 interrupt, PIN1 uses settings for EXTI1, and so on.

For example, to route PB00 as a producer for PRS channel 2, EXTI0, EXTI1, EXTI2, or EXTI3 should be configured to connect to PB00, and the corresponding GPIO PINx should be selected as the PRS channel 2 producer. If we choose EXTI1 via PRS producer "GPIO PIN1":

1. GPIO_EXTIPSELL_EXTIPSEL1 = PORTB, and GPIO_EXTIPINSELL_EXTIPINSEL1 = PIN0 connect PB00 through the EXTI1 signal.
2. PRS_ASYNC_CH2_CTRL_SOURCESEL = GPIO, and PRS_ASYNC_CH2_CTRL_SIGSEL = PIN1 connects the PIN1 (EXTI1) signal to asynchronous PRS channel 2 as a producer.

13.3.3.1 Producer Details

Table 13.4. Synchronous PRS Producers

Peripheral	SOURCESEL	Signal	SIGSEL
TIMER0	TIMER0 (0x01)	UF	0x0
		OF	0x1
		CC0	0x2
		CC1	0x3
		CC2	0x4
TIMER1	TIMER1 (0x02)	UF	0x0
		OF	0x1
		CC0	0x2
		CC1	0x3
		CC2	0x4
IADC0	IADC0 (0x03)	SCANENTRYDONE	0x0
		SCANTABLEDONE	0x1
		SINGLEDONE	0x2
TIMER2	TIMER2 (0x04)	UF	0x0
		OF	0x1
		CC0	0x2
		CC1	0x3
		CC2	0x4
TIMER3	TIMER3 (0x05)	UF	0x0
		OF	0x1
		CC0	0x2
		CC1	0x3
		CC2	0x4
TIMER4	TIMER4 (0x06)	UF	0x0
		OF	0x1
		CC0	0x2
		CC1	0x3
		CC2	0x4
VDAC0	VDAC0 (0x07)	CH0DONESYNC	0x0
		CH1DONESYNC	0x1
VDAC1	VDAC1 (0x08)	CH0DONESYNC	0x0
		CH1DONESYNC	0x1

Table 13.5. Asynchronous PRS Producers

Peripheral	SOURCESEL	Signal	SIGSEL
IADC0	IADC0 (0x01)	SCANENTRYDONE	0x0
		SCANTABLEDONE	0x1
		SINGLEDONE	0x2
LETIMER0	LETIMER0 (0x02)	CH0	0x0
		CH1	0x1
BURTC	BURTC (0x03)	COMP	0x0
		OVERFLOW	0x1
GPIO	GPIO (0x04)	PIN0	0x0
		PIN1	0x1
		PIN2	0x2
		PIN3	0x3
		PIN4	0x4
		PIN5	0x5
		PIN6	0x6
		PIN7	0x7
CMU	CMUL (0x05)	CLKOUT0	0x0
		CLKOUT1	0x1
		CLKOUT2	0x2
PRS	PRSL (0x08)	ASYNCH0	0x0
		ASYNCH1	0x1
		ASYNCH2	0x2
		ASYNCH3	0x3
		ASYNCH4	0x4
		ASYNCH5	0x5
		ASYNCH6	0x6
		ASYNCH7	0x7
	PRS (0x09)	ASYNCH8	0x0
		ASYNCH9	0x1
		ASYNCH10	0x2
ASYNCH11		0x3	
ACMP0	ACMP0 (0x0A)	OUT	0x0
ACMP1	ACMP1 (0x0B)	OUT	0x0
PCNT0	PCNT0 (0x0C)	DIR	0x0
		UFOF	0x1

Peripheral	SOURCESEL	Signal	SIGSEL
SYSRTC0	SYSRTC0 (0x0D)	GRP0OUT0	0x0
		GRP0OUT1	0x1
		GRP1OUT0	0x2
		GRP1OUT1	0x3
HFXO0	HFXO0L (0x0E)	STATUS	0x0
		STATUS1	0x1
EUSART0	EUSART0L (0x10)	CS	0x0
		IRDATX	0x1
		RTS	0x2
		RXDATAV	0x3
		TX	0x4
		TXC	0x5
		RXFL	0x6
		TXFL	0x7
VDAC0	VDAC0L (0x12)	CH0WARM	0x0
		CH1WARM	0x1
		CH0DONEASYNC	0x2
		CH1DONEASYNC	0x3
		INTERNALTIMEROF	0x4
		REFRESHTIMEROF	0x5
VDAC1	VDAC1L (0x14)	CH0WARM	0x0
		CH1WARM	0x1
		CH0DONEASYNC	0x2
		CH1DONEASYNC	0x3
		INTERNALTIMEROF	0x4
		REFRESHTIMEROF	0x5
LFRCO	LFRCO (0x18)	CALMEAS	0x0
		SDM	0x1
		TCMEAS	0x2
USART0	USART0 (0x20)	CS	0x0
		IRTX	0x1
		RTS	0x2
		RXDATA	0x3
		TX	0x4
		TXC	0x5

Peripheral	SOURCESEL	Signal	SIGSEL
TIMER0	TIMER0 (0x21)	UF	0x0
		OF	0x1
		CC0	0x2
		CC1	0x3
		CC2	0x4
TIMER1	TIMER1 (0x22)	UF	0x0
		OF	0x1
		CC0	0x2
		CC1	0x3
		CC2	0x4
TIMER2	TIMER2 (0x23)	UF	0x0
		OF	0x1
		CC0	0x2
		CC1	0x3
		CC2	0x4
TIMER3	TIMER3 (0x24)	UF	0x0
		OF	0x1
		CC0	0x2
		CC1	0x3
		CC2	0x4
CORE	CORE (0x25)	CTIOUT0	0x0
		CTIOUT1	0x1
		CTIOUT2	0x2
		CTIOUT3	0x3
AGC	AGCL (0x26)	CCA	0x0
		CCAREQ	0x1
		GAINADJUST	0x2
		GAINOK	0x3
		GAINREDUCED	0x4
		IFPKI1	0x5
		IFPKQ2	0x6
		IFPKRST	0x7
	AGC (0x27)	PEAKDET	0x0
		PROPAGATED	0x1
RSSIDONE		0x2	

Peripheral	SOURCESEL	Signal	SIGSEL
BUFC	BUFC (0x28)	THR0	0x0
		THR1	0x1
		THR2	0x2
		THR3	0x3
		CNT0	0x4
		CNT1	0x5
		FULL	0x6
MODEM	MODEML (0x29)	ADVANCE	0x0
		ANT0	0x1
		ANT1	0x2
		COHDSADET	0x3
		COHDSALIVE	0x4
		DCLK	0x5
		DOUT	0x6
		FRAMEDET	0x7
	MODEM (0x2A)	FRAMESENT	0x0
		LOWCORR	0x1
		LRDSADET	0x2
		LRDSALIVE	0x3
		NEWSYMBOL	0x4
		NEWWND	0x5
		POSTPONE	0x6
		PREDET	0x7
	MODEMH (0x2B)	PRESENT	0x0
		RSSIJUMP	0x1
		SYNCSSENT	0x2
		TIMDET	0x3
		WEAK	0x4
EOF		0x5	
SI		0x6	
FRC	FRC (0x2C)	DCLK	0x0
		DOUT	0x1

Peripheral	SOURCESEL	Signal	SIGSEL
PROTIMER	PROTIMERL (0x2D)	BOF	0x0
		CC0	0x1
		CC1	0x2
		CC2	0x3
		CC3	0x4
		CC4	0x5
		LBTF	0x6
		LBTR	0x7
	PROTIMER (0x2E)	LBTS	0x0
		POF	0x1
		T0MATCH	0x2
		T0UF	0x3
		T1MATCH	0x4
		T1UF	0x5
		WOF	0x6
SYNTH	SYNTH (0x2F)	MUX0	0x0
		MUX1	0x1
RAC	RACL (0x30)	ACTIVE	0x0
		LNAEN	0x1
		PAEN	0x2
		RX	0x3
		TX	0x4
		CTIOUT0	0x5
		CTIOUT1	0x6
		CTIOUT2	0x7
	RAC (0x31)	CTIOUT3	0x0
		AUXADCDATA	0x1
		AUXADCDATAVALID	0x2
TIMER4	TIMER4 (0x32)	UF	0x0
		OF	0x1
		CC0	0x2
		CC1	0x3
		CC2	0x4

Peripheral	SOURCESEL	Signal	SIGSEL
EUSART1	EUSART1L (0x33)	CS	0x0
		IRDATX	0x1
		RTS	0x2
		RXDATAV	0x3
		TX	0x4
		TXC	0x5
		RXFL	0x6
		TXFL	0x7

13.3.4 Consumers

Consumer peripherals can be set to listen to a PRS channel and perform an action based on the signal received on that channel. This is done by programming the PRSSEL or SPRSSEL in the consumer registers. SPRSSEL is only present for signals with the ability to listen to synchronous channels. The consumer registers follow the naming convention PRS_CONSUMER_<peripheral_name>_<signal_name>. For example, the PRS_CONSUMER_TIMER0_CC0 register is used to select which PRS channel output is sent to the TIMER0 peripheral's CC0 signal. In turn, the target peripheral should be configured to use the associated PRS trigger as desired. This is described in the individual peripheral chapters.

Note: When configuring the synchronous PRS consumer registers, the target peripheral should be disabled or configured to not use the affected PRS signal. This will ensure that no false triggers occur at the consumer.

13.3.4.1 Event on PRS

The PRS can be used to send events to the MCU to wake the system. This is very useful in combination with the Wait For Event (WFE) instruction. Any asynchronous PRS channel can be selected for this using PRSSEL in PRS_CONSUMER_CORE_M33RXEV.

Using this feature, one can e.g. set up a timer to trigger an event to the MCU periodically, every time letting the MCU continue from a WFE instruction in its program. This can help in performance-critical sections where timing is known, and the goal is to wait for an event, execute some code, then wait for another event, execute some code, and so on.

13.3.4.2 DMA Request on PRS

Up to two independent DMA requests can be generated by the PRS. The PRS asynchronous channels triggering the DMA requests are selected with the PRSSEL fields in the PRS_CONSUMER_LDMAXBAR_DMAREQx registers. The requests are set whenever the selected asynchronous PRS outputs are high.

13.4 PRS Register Map

The offset register address is relative to the registers base address.

Offset	Name	Type	Description
0x000	PRS_IPVERSION	R	PRS IPVERSION
0x008	PRS_ASYNC_SWPULSE	W	Software Pulse Register
0x00C	PRS_ASYNC_SWLEVEL	RW	Software Level Register
0x010	PRS_ASYNC_PEEK	RH	Async Channel Values
0x014	PRS_SYNC_PEEK	RH	Sync Channel Values
0x018	PRS_ASYNC_CHx_CTRL	RW	Async Channel Control Register
0x058	PRS_SYNC_CHx_CTRL	RW	Sync Channel Control Register
0x068	PRS_CONSUMER_CMU_CALDN	RW	CALDN Consumer Register
0x06C	PRS_CONSUMER_CMU_CALUP	RW	CALUP Consumer Register
0x070	PRS_CONSUMER_EU-SART0_CLK	RW	CLK Consumer Register
0x074	PRS_CONSUMER_EU-SART0_RX	RW	RX Consumer Register
0x078	PRS_CONSUMER_EU-SART0_TRIGGER	RW	TRIGGER Consumer Register
0x07C	PRS_CONSUMER_EU-SART1_CLK	RW	CLK Consumer Register
0x080	PRS_CONSUMER_EU-SART1_RX	RW	RX Consumer Register
0x084	PRS_CONSUMER_EU-SART1_TRIGGER	RW	TRIGGER Consumer Register
0x08C	PRS_CONSUMER_IADC0_SCANTRIGGER	RW	SCAN Consumer Register
0x090	PRS_CONSUMER_IADC0_SINGLETRIGGER	RW	SINGLE Consumer Register
0x094	PRS_CONSUMER_LDMAX-BAR_DMAREQ0	RW	DMAREQ0 Consumer Register
0x098	PRS_CONSUMER_LDMAX-BAR_DMAREQ1	RW	DMAREQ1 Consumer Register
0x09C	PRS_CONSUMER_LETIMER0_CLEAR	RW	CLEAR Consumer Register
0x0A0	PRS_CONSUMER_LETIMER0_START	RW	START Consumer Register
0x0A4	PRS_CONSUMER_LETIMER0_STOP	RW	STOP Consumer Register
0x0A8	PRS_CONSUMER_MODEM_DIN	RW	DIN Consumer Register
0x0AC	PRS_CONSUMER_MODEM_PAEN	RW	PAEN Consumer Register

Offset	Name	Type	Description
0x0B0	PRS_CONSUMER_PCNT0_S0IN	RW	S0IN Consumer Register
0x0B4	PRS_CONSUMER_PCNT0_S1IN	RW	S1IN Consumer Register
0x0E4	PRS_CONSUMER_RAC_CLR	RW	CLR Consumer Register
0x0E8	PRS_CONSUMER_RAC_CTIIN0	RW	CTI Consumer Register
0x0EC	PRS_CONSUMER_RAC_CTIIN1	RW	CTI Consumer Register
0x0F0	PRS_CONSUMER_RAC_CTIIN2	RW	CTI Consumer Register
0x0F4	PRS_CONSUMER_RAC_CTIIN3	RW	CTI Consumer Register
0x0F8	PRS_CONSUMER_RAC_FORCETX	RW	FORCETX Consumer Register
0x0FC	PRS_CONSUMER_RAC_RXDIS	RW	RXDIS Consumer Register
0x100	PRS_CONSUMER_RAC_RXEN	RW	RXEN Consumer Register
0x104	PRS_CONSUMER_RAC_TXEN	RW	TXEN Consumer Register
0x108	PRS_CONSUMER_SETAMPER_TAMPERSRC25	RW	TAMPERSRC25 Consumer Register
0x10C	PRS_CONSUMER_SETAMPER_TAMPERSRC26	RW	TAMPERSRC26 Consumer Register
0x110	PRS_CONSUMER_SETAMPER_TAMPERSRC27	RW	TAMPERSRC27 Consumer Register
0x114	PRS_CONSUMER_SETAMPER_TAMPERSRC28	RW	TAMPERSRC28 Consumer Register
0x118	PRS_CONSUMER_SETAMPER_TAMPERSRC29	RW	TAMPERSRC29 Consumer Register
0x11C	PRS_CONSUMER_SETAMPER_TAMPERSRC30	RW	TAMPERSRC30 Consumer Register
0x120	PRS_CONSUMER_SETAMPER_TAMPERSRC31	RW	TAMPERSRC31 Consumer Register
0x124	PRS_CONSUMER_SYSRTC0_IN0	RW	IN0 Consumer Register
0x128	PRS_CONSUMER_SYSRTC0_IN1	RW	IN1 Consumer Register
0x12C	PRS_CONSUMER_HFXO0_OSCREQ	RW	OSCREQ Consumer Register
0x130	PRS_CONSUMER_HFXO0_TIMEOUT	RW	TIMEOUT Consumer Register
0x134	PRS_CONSUMER_CORE_CTIIN0	RW	CTI0 Consumer Selection
0x138	PRS_CONSUMER_CORE_CTIIN1	RW	CTI1 Consumer Selection
0x13C	PRS_CONSUMER_CORE_CTIIN2	RW	CTI2 Consumer Selection
0x140	PRS_CONSUMER_CORE_CTIIN3	RW	CTI3 Consumer Selection

Offset	Name	Type	Description
0x144	PRS_CONSUMER_CORE_M33RXEV	RW	M33 Consumer Selection
0x148	PRS_CONSUMER_TIMER0_CC0	RW	CC0 Consumer Register
0x14C	PRS_CONSUMER_TIMER0_CC1	RW	CC1 Consumer Register
0x150	PRS_CONSUMER_TIMER0_CC2	RW	CC2 Consumer Register
0x154	PRS_CONSUMER_TIMER0_DTI	RW	DTI Consumer Register
0x158	PRS_CONSUMER_TIMER0_DTIFS1	RW	DTI Consumer Register
0x15C	PRS_CONSUMER_TIMER0_DTIFS2	RW	DTI Consumer Register
0x160	PRS_CONSUMER_TIMER1_CC0	RW	CC0 Consumer Register
0x164	PRS_CONSUMER_TIMER1_CC1	RW	CC1 Consumer Register
0x168	PRS_CONSUMER_TIMER1_CC2	RW	CC2 Consumer Register
0x16C	PRS_CONSUMER_TIMER1_DTI	RW	DTI Consumer Register
0x170	PRS_CONSUMER_TIMER1_DTIFS1	RW	DTI Consumer Register
0x174	PRS_CONSUMER_TIMER1_DTIFS2	RW	DTI Consumer Register
0x178	PRS_CONSUMER_TIMER2_CC0	RW	CC0 Consumer Register
0x17C	PRS_CONSUMER_TIMER2_CC1	RW	CC1 Consumer Register
0x180	PRS_CONSUMER_TIMER2_CC2	RW	CC2 Consumer Register
0x184	PRS_CONSUMER_TIMER2_DTI	RW	DTI Consumer Register
0x188	PRS_CONSUMER_TIMER2_DTIFS1	RW	DTI Consumer Register
0x18C	PRS_CONSUMER_TIMER2_DTIFS2	RW	DTI Consumer Register
0x190	PRS_CONSUMER_TIMER3_CC0	RW	CC0 Consumer Register
0x194	PRS_CONSUMER_TIMER3_CC1	RW	CC1 Consumer Register
0x198	PRS_CONSUMER_TIMER3_CC2	RW	CC2 Consumer Register
0x19C	PRS_CONSUMER_TIMER3_DTI	RW	DTI Consumer Register
0x1A0	PRS_CONSUMER_TIMER3_DTIFS1	RW	DTI Consumer Register
0x1A4	PRS_CONSUMER_TIMER3_DTIFS2	RW	DTI Consumer Register

Offset	Name	Type	Description
0x1A8	PRS_CONSUMER_TIMER4_CC0	RW	CC0 Consumer Register
0x1AC	PRS_CONSUMER_TIMER4_CC1	RW	CC1 Consumer Register
0x1B0	PRS_CONSUMER_TIMER4_CC2	RW	CC2 Consumer Register
0x1B4	PRS_CONSUMER_TIMER4_DTI	RW	DTI Consumer Register
0x1B8	PRS_CONSUMER_TIMER4_DTIFS1	RW	DTI Consumer Register
0x1BC	PRS_CONSUMER_TIMER4_DTIFS2	RW	DTI Consumer Register
0x1C0	PRS_CONSUMER_USART0_CLK	RW	CLK Consumer Register
0x1C4	PRS_CONSUMER_USART0_IR	RW	IR Consumer Register
0x1C8	PRS_CONSUMER_USART0_RX	RW	RX Consumer Register
0x1CC	PRS_CONSUMER_USART0_TRIGGER	RW	TRIGGER Consumer Register
0x1DC	PRS_CONSUMER_VDAC0_ASYNCTRIGCH0	RW	ASYNCTRIG Consumer Register
0x1E0	PRS_CONSUMER_VDAC0_ASYNCTRIGCH1	RW	ASYNCTRIG Consumer Register
0x1E4	PRS_CONSUMER_VDAC0_SYNCTRIGCH0	RW	SYNCTRIG Consumer Register
0x1E8	PRS_CONSUMER_VDAC0_SYNCTRIGCH1	RW	SYNCTRIG Consumer Register
0x1EC	PRS_CONSUMER_VDAC1_ASYNCTRIGCH0	RW	ASYNCTRIG Consumer Register
0x1F0	PRS_CONSUMER_VDAC1_ASYNCTRIGCH1	RW	ASYNCTRIG Consumer Register
0x1F4	PRS_CONSUMER_VDAC1_SYNCTRIGCH0	RW	SYNCTRIG Consumer Register
0x1F8	PRS_CONSUMER_VDAC1_SYNCTRIGCH1	RW	SYNCTRIG Consumer Register
0x1FC	PRS_CONSUMER_WDOG0_SRC0	RW	SRC0 Consumer Register
0x200	PRS_CONSUMER_WDOG0_SRC1	RW	SRC1 Consumer Register
0x204	PRS_CONSUMER_WDOG1_SRC0	RW	SRC0 Consumer Register
0x208	PRS_CONSUMER_WDOG1_SRC1	RW	SRC1 Consumer Register
0x1000	PRS_IPVERSION_SET	R	PRS IPVERSION
0x1008	PRS_ASYNC_SWPULSE_SET	W	Software Pulse Register
0x100C	PRS_ASYNC_SWLEVEL_SET	RW	Software Level Register
0x1010	PRS_ASYNC_PEEK_SET	RH	Async Channel Values

Offset	Name	Type	Description
0x1014	PRS_SYNC_PEEK_SET	RH	Sync Channel Values
0x1018	PRS_ASYNC_CHx_CTRL_SET	RW	Async Channel Control Register
0x1058	PRS_SYNC_CHx_CTRL_SET	RW	Sync Channel Control Register
0x1068	PRS_CONSUMER_CMU_CALDN_SET	RW	CALDN Consumer Register
0x106C	PRS_CONSUMER_CMU_CALUP_SET	RW	CALUP Consumer Register
0x1070	PRS_CONSUMER_EU-SART0_CLK_SET	RW	CLK Consumer Register
0x1074	PRS_CONSUMER_EU-SART0_RX_SET	RW	RX Consumer Register
0x1078	PRS_CONSUMER_EU-SART0_TRIGGER_SET	RW	TRIGGER Consumer Register
0x107C	PRS_CONSUMER_EU-SART1_CLK_SET	RW	CLK Consumer Register
0x1080	PRS_CONSUMER_EU-SART1_RX_SET	RW	RX Consumer Register
0x1084	PRS_CONSUMER_EU-SART1_TRIGGER_SET	RW	TRIGGER Consumer Register
0x108C	PRS_CONSUMER_IADC0_SCANTRIGGER_SET	RW	SCAN Consumer Register
0x1090	PRS_CONSUMER_IADC0_SINGLETRIGGER_SET	RW	SINGLE Consumer Register
0x1094	PRS_CONSUMER_LDMAX-BAR_DMAREQ0_SET	RW	DMAREQ0 Consumer Register
0x1098	PRS_CONSUMER_LDMAX-BAR_DMAREQ1_SET	RW	DMAREQ1 Consumer Register
0x109C	PRS_CONSUMER_LETIMER0_CLEAR_SET	RW	CLEAR Consumer Register
0x10A0	PRS_CONSUMER_LETIMER0_START_SET	RW	START Consumer Register
0x10A4	PRS_CONSUMER_LETIMER0_STOP_SET	RW	STOP Consumer Register
0x10A8	PRS_CONSUMER_MODEM_DIN_SET	RW	DIN Consumer Register
0x10AC	PRS_CONSUMER_MODEM_PAEN_SET	RW	PAEN Consumer Register
0x10B0	PRS_CONSUMER_PCNT0_S0IN_SET	RW	S0IN Consumer Register
0x10B4	PRS_CONSUMER_PCNT0_S1IN_SET	RW	S1IN Consumer Register
0x10E4	PRS_CONSUMER_RAC_CLR_SET	RW	CLR Consumer Register
0x10E8	PRS_CONSUMER_RAC_CTIIN0_SET	RW	CTI Consumer Register

Offset	Name	Type	Description
0x10EC	PRS_CONSUMER_RAC_CTIIN1_SET	RW	CTI Consumer Register
0x10F0	PRS_CONSUMER_RAC_CTIIN2_SET	RW	CTI Consumer Register
0x10F4	PRS_CONSUMER_RAC_CTIIN3_SET	RW	CTI Consumer Register
0x10F8	PRS_CONSUMER_RAC_FORCETX_SET	RW	FORCETX Consumer Register
0x10FC	PRS_CONSUMER_RAC_RXDIS_SET	RW	RXDIS Consumer Register
0x1100	PRS_CONSUMER_RAC_RXEN_SET	RW	RXEN Consumer Register
0x1104	PRS_CONSUMER_RAC_TXEN_SET	RW	TXEN Consumer Register
0x1108	PRS_CONSUMER_SETAMPER_TAMPERSRC25_SET	RW	TAMPERSRC25 Consumer Register
0x110C	PRS_CONSUMER_SETAMPER_TAMPERSRC26_SET	RW	TAMPERSRC26 Consumer Register
0x1110	PRS_CONSUMER_SETAMPER_TAMPERSRC27_SET	RW	TAMPERSRC27 Consumer Register
0x1114	PRS_CONSUMER_SETAMPER_TAMPERSRC28_SET	RW	TAMPERSRC28 Consumer Register
0x1118	PRS_CONSUMER_SETAMPER_TAMPERSRC29_SET	RW	TAMPERSRC29 Consumer Register
0x111C	PRS_CONSUMER_SETAMPER_TAMPERSRC30_SET	RW	TAMPERSRC30 Consumer Register
0x1120	PRS_CONSUMER_SETAMPER_TAMPERSRC31_SET	RW	TAMPERSRC31 Consumer Register
0x1124	PRS_CONSUMER_SYSRTC0_IN0_SET	RW	IN0 Consumer Register
0x1128	PRS_CONSUMER_SYSRTC0_IN1_SET	RW	IN1 Consumer Register
0x112C	PRS_CONSUMER_HFXO0_OSCREQ_SET	RW	OSCREQ Consumer Register
0x1130	PRS_CONSUMER_HFXO0_TIMEOUT_SET	RW	TIMEOUT Consumer Register
0x1134	PRS_CONSUMER_CORE_CTIIN0_SET	RW	CTI0 Consumer Selection
0x1138	PRS_CONSUMER_CORE_CTIIN1_SET	RW	CTI1 Consumer Selection
0x113C	PRS_CONSUMER_CORE_CTIIN2_SET	RW	CTI2 Consumer Selection
0x1140	PRS_CONSUMER_CORE_CTIIN3_SET	RW	CTI3 Consumer Selection
0x1144	PRS_CONSUMER_CORE_M33RXEV_SET	RW	M33 Consumer Selection

Offset	Name	Type	Description
0x1148	PRS_CONSUMER_TIMER0_CC0_SET	RW	CC0 Consumer Register
0x114C	PRS_CONSUMER_TIMER0_CC1_SET	RW	CC1 Consumer Register
0x1150	PRS_CONSUMER_TIMER0_CC2_SET	RW	CC2 Consumer Register
0x1154	PRS_CONSUMER_TIMER0_DTI_SET	RW	DTI Consumer Register
0x1158	PRS_CONSUMER_TIMER0_DTIFS1_SET	RW	DTI Consumer Register
0x115C	PRS_CONSUMER_TIMER0_DTIFS2_SET	RW	DTI Consumer Register
0x1160	PRS_CONSUMER_TIMER1_CC0_SET	RW	CC0 Consumer Register
0x1164	PRS_CONSUMER_TIMER1_CC1_SET	RW	CC1 Consumer Register
0x1168	PRS_CONSUMER_TIMER1_CC2_SET	RW	CC2 Consumer Register
0x116C	PRS_CONSUMER_TIMER1_DTI_SET	RW	DTI Consumer Register
0x1170	PRS_CONSUMER_TIMER1_DTIFS1_SET	RW	DTI Consumer Register
0x1174	PRS_CONSUMER_TIMER1_DTIFS2_SET	RW	DTI Consumer Register
0x1178	PRS_CONSUMER_TIMER2_CC0_SET	RW	CC0 Consumer Register
0x117C	PRS_CONSUMER_TIMER2_CC1_SET	RW	CC1 Consumer Register
0x1180	PRS_CONSUMER_TIMER2_CC2_SET	RW	CC2 Consumer Register
0x1184	PRS_CONSUMER_TIMER2_DTI_SET	RW	DTI Consumer Register
0x1188	PRS_CONSUMER_TIMER2_DTIFS1_SET	RW	DTI Consumer Register
0x118C	PRS_CONSUMER_TIMER2_DTIFS2_SET	RW	DTI Consumer Register
0x1190	PRS_CONSUMER_TIMER3_CC0_SET	RW	CC0 Consumer Register
0x1194	PRS_CONSUMER_TIMER3_CC1_SET	RW	CC1 Consumer Register
0x1198	PRS_CONSUMER_TIMER3_CC2_SET	RW	CC2 Consumer Register
0x119C	PRS_CONSUMER_TIMER3_DTI_SET	RW	DTI Consumer Register
0x11A0	PRS_CONSUMER_TIMER3_DTIFS1_SET	RW	DTI Consumer Register

Offset	Name	Type	Description
0x11A4	PRS_CONSUMER_TIMER3_DTIFS2_SET	RW	DTI Consumer Register
0x11A8	PRS_CONSUMER_TIMER4_CC0_SET	RW	CC0 Consumer Register
0x11AC	PRS_CONSUMER_TIMER4_CC1_SET	RW	CC1 Consumer Register
0x11B0	PRS_CONSUMER_TIMER4_CC2_SET	RW	CC2 Consumer Register
0x11B4	PRS_CONSUMER_TIMER4_DTI_SET	RW	DTI Consumer Register
0x11B8	PRS_CONSUMER_TIMER4_DTIFS1_SET	RW	DTI Consumer Register
0x11BC	PRS_CONSUMER_TIMER4_DTIFS2_SET	RW	DTI Consumer Register
0x11C0	PRS_CONSUMER_USART0_CLK_SET	RW	CLK Consumer Register
0x11C4	PRS_CONSUMER_USART0_IR_SET	RW	IR Consumer Register
0x11C8	PRS_CONSUMER_USART0_RX_SET	RW	RX Consumer Register
0x11CC	PRS_CONSUMER_USART0_TRIGGER_SET	RW	TRIGGER Consumer Register
0x11DC	PRS_CONSUMER_VDAC0_ASYNCCTRIGCH0_SET	RW	ASYNCTRIG Consumer Register
0x11E0	PRS_CONSUMER_VDAC0_ASYNCCTRIGCH1_SET	RW	ASYNCTRIG Consumer Register
0x11E4	PRS_CONSUMER_VDAC0_SYNCTRIGCH0_SET	RW	SYNCTRIG Consumer Register
0x11E8	PRS_CONSUMER_VDAC0_SYNCTRIGCH1_SET	RW	SYNCTRIG Consumer Register
0x11EC	PRS_CONSUMER_VDAC1_ASYNCCTRIGCH0_SET	RW	ASYNCTRIG Consumer Register
0x11F0	PRS_CONSUMER_VDAC1_ASYNCCTRIGCH1_SET	RW	ASYNCTRIG Consumer Register
0x11F4	PRS_CONSUMER_VDAC1_SYNCTRIGCH0_SET	RW	SYNCTRIG Consumer Register
0x11F8	PRS_CONSUMER_VDAC1_SYNCTRIGCH1_SET	RW	SYNCTRIG Consumer Register
0x11FC	PRS_CONSUMER_WDOG0_SRC0_SET	RW	SRC0 Consumer Register

Offset	Name	Type	Description
0x1200	PRS_CONSUMER_WDOG0_SRC1_SET	RW	SRC1 Consumer Register
0x1204	PRS_CONSUMER_WDOG1_SRC0_SET	RW	SRC0 Consumer Register
0x1208	PRS_CONSUMER_WDOG1_SRC1_SET	RW	SRC1 Consumer Register
0x2000	PRS_IPVERSION_CLR	R	PRS IPVERSION
0x2008	PRS_ASYNC_SWPULSE_CLR	W	Software Pulse Register
0x200C	PRS_ASYNC_SWLEVEL_CLR	RW	Software Level Register
0x2010	PRS_ASYNC_PEEK_CLR	RH	Async Channel Values
0x2014	PRS_SYNC_PEEK_CLR	RH	Sync Channel Values
0x2018	PRS_ASYNC_CHx_CTRL_CLR	RW	Async Channel Control Register
0x2058	PRS_SYNC_CHx_CTRL_CLR	RW	Sync Channel Control Register
0x2068	PRS_CONSUMER_CMU_CALDN_CLR	RW	CALDN Consumer Register
0x206C	PRS_CONSUMER_CMU_CALUP_CLR	RW	CALUP Consumer Register
0x2070	PRS_CONSUMER_EU_SART0_CLK_CLR	RW	CLK Consumer Register
0x2074	PRS_CONSUMER_EU_SART0_RX_CLR	RW	RX Consumer Register
0x2078	PRS_CONSUMER_EU_SART0_TRIGGER_CLR	RW	TRIGGER Consumer Register
0x207C	PRS_CONSUMER_EU_SART1_CLK_CLR	RW	CLK Consumer Register
0x2080	PRS_CONSUMER_EU_SART1_RX_CLR	RW	RX Consumer Register
0x2084	PRS_CONSUMER_EU_SART1_TRIGGER_CLR	RW	TRIGGER Consumer Register
0x208C	PRS_CONSUMER_IADC0_SCANTRIGGER_CLR	RW	SCAN Consumer Register
0x2090	PRS_CONSUMER_IADC0_SINGLETRIGGER_CLR	RW	SINGLE Consumer Register
0x2094	PRS_CONSUMER_LDMAXBAR_DMAREQ0_CLR	RW	DMAREQ0 Consumer Register
0x2098	PRS_CONSUMER_LDMAXBAR_DMAREQ1_CLR	RW	DMAREQ1 Consumer Register
0x209C	PRS_CONSUMER_LETIMER0_CLEAR_CLR	RW	CLEAR Consumer Register
0x20A0	PRS_CONSUMER_LETIMER0_START_CLR	RW	START Consumer Register
0x20A4	PRS_CONSUMER_LETIMER0_STOP_CLR	RW	STOP Consumer Register

Offset	Name	Type	Description
0x20A8	PRS_CONSUMER_MOD- DEM_DIN_CLR	RW	DIN Consumer Register
0x20AC	PRS_CONSUMER_MOD- DEM_PAEN_CLR	RW	PAEN Consumer Register
0x20B0	PRS_CONSUM- ER_PCNT0_S0IN_CLR	RW	S0IN Consumer Register
0x20B4	PRS_CONSUM- ER_PCNT0_S1IN_CLR	RW	S1IN Consumer Register
0x20E4	PRS_CONSUM- ER_RAC_CLR_CLR	RW	CLR Consumer Register
0x20E8	PRS_CONSUM- ER_RAC_CTIIN0_CLR	RW	CTI Consumer Register
0x20EC	PRS_CONSUM- ER_RAC_CTIIN1_CLR	RW	CTI Consumer Register
0x20F0	PRS_CONSUM- ER_RAC_CTIIN2_CLR	RW	CTI Consumer Register
0x20F4	PRS_CONSUM- ER_RAC_CTIIN3_CLR	RW	CTI Consumer Register
0x20F8	PRS_CONSUM- ER_RAC_FORCETX_CLR	RW	FORCETX Consumer Register
0x20FC	PRS_CONSUM- ER_RAC_RXDIS_CLR	RW	RXDIS Consumer Register
0x2100	PRS_CONSUM- ER_RAC_RXEN_CLR	RW	RXEN Consumer Register
0x2104	PRS_CONSUM- ER_RAC_TXEN_CLR	RW	TXEN Consumer Register
0x2108	PRS_CONSUMER_SETAM- PER_TAMPERSRC25_CLR	RW	TAMPERSRC25 Consumer Register
0x210C	PRS_CONSUMER_SETAM- PER_TAMPERSRC26_CLR	RW	TAMPERSRC26 Consumer Register
0x2110	PRS_CONSUMER_SETAM- PER_TAMPERSRC27_CLR	RW	TAMPERSRC27 Consumer Register
0x2114	PRS_CONSUMER_SETAM- PER_TAMPERSRC28_CLR	RW	TAMPERSRC28 Consumer Register
0x2118	PRS_CONSUMER_SETAM- PER_TAMPERSRC29_CLR	RW	TAMPERSRC29 Consumer Register
0x211C	PRS_CONSUMER_SETAM- PER_TAMPERSRC30_CLR	RW	TAMPERSRC30 Consumer Register
0x2120	PRS_CONSUMER_SETAM- PER_TAMPERSRC31_CLR	RW	TAMPERSRC31 Consumer Register
0x2124	PRS_CONSUM- ER_SYSRTC0_IN0_CLR	RW	IN0 Consumer Register
0x2128	PRS_CONSUM- ER_SYSRTC0_IN1_CLR	RW	IN1 Consumer Register
0x212C	PRS_CONSUMER_HFXO0_OS- CREQ_CLR	RW	OSCREQ Consumer Register

Offset	Name	Type	Description
0x2130	PRS_CONSUMER_HFX00_TIMEOUT_CLR	RW	TIMEOUT Consumer Register
0x2134	PRS_CONSUMER_CORE_CTIIN0_CLR	RW	CTI0 Consumer Selection
0x2138	PRS_CONSUMER_CORE_CTIIN1_CLR	RW	CTI1 Consumer Selection
0x213C	PRS_CONSUMER_CORE_CTIIN2_CLR	RW	CTI2 Consumer Selection
0x2140	PRS_CONSUMER_CORE_CTIIN3_CLR	RW	CTI3 Consumer Selection
0x2144	PRS_CONSUMER_CORE_M33RXEV_CLR	RW	M33 Consumer Selection
0x2148	PRS_CONSUMER_TIMER0_CC0_CLR	RW	CC0 Consumer Register
0x214C	PRS_CONSUMER_TIMER0_CC1_CLR	RW	CC1 Consumer Register
0x2150	PRS_CONSUMER_TIMER0_CC2_CLR	RW	CC2 Consumer Register
0x2154	PRS_CONSUMER_TIMER0_DTI_CLR	RW	DTI Consumer Register
0x2158	PRS_CONSUMER_TIMER0_DTIFS1_CLR	RW	DTI Consumer Register
0x215C	PRS_CONSUMER_TIMER0_DTIFS2_CLR	RW	DTI Consumer Register
0x2160	PRS_CONSUMER_TIMER1_CC0_CLR	RW	CC0 Consumer Register
0x2164	PRS_CONSUMER_TIMER1_CC1_CLR	RW	CC1 Consumer Register
0x2168	PRS_CONSUMER_TIMER1_CC2_CLR	RW	CC2 Consumer Register
0x216C	PRS_CONSUMER_TIMER1_DTI_CLR	RW	DTI Consumer Register
0x2170	PRS_CONSUMER_TIMER1_DTIFS1_CLR	RW	DTI Consumer Register
0x2174	PRS_CONSUMER_TIMER1_DTIFS2_CLR	RW	DTI Consumer Register
0x2178	PRS_CONSUMER_TIMER2_CC0_CLR	RW	CC0 Consumer Register
0x217C	PRS_CONSUMER_TIMER2_CC1_CLR	RW	CC1 Consumer Register
0x2180	PRS_CONSUMER_TIMER2_CC2_CLR	RW	CC2 Consumer Register
0x2184	PRS_CONSUMER_TIMER2_DTI_CLR	RW	DTI Consumer Register
0x2188	PRS_CONSUMER_TIMER2_DTIFS1_CLR	RW	DTI Consumer Register

Offset	Name	Type	Description
0x218C	PRS_CONSUMER_TIMER2_DTIFS2_CLR	RW	DTI Consumer Register
0x2190	PRS_CONSUMER_TIMER3_CC0_CLR	RW	CC0 Consumer Register
0x2194	PRS_CONSUMER_TIMER3_CC1_CLR	RW	CC1 Consumer Register
0x2198	PRS_CONSUMER_TIMER3_CC2_CLR	RW	CC2 Consumer Register
0x219C	PRS_CONSUMER_TIMER3_DTI_CLR	RW	DTI Consumer Register
0x21A0	PRS_CONSUMER_TIMER3_DTIFS1_CLR	RW	DTI Consumer Register
0x21A4	PRS_CONSUMER_TIMER3_DTIFS2_CLR	RW	DTI Consumer Register
0x21A8	PRS_CONSUMER_TIMER4_CC0_CLR	RW	CC0 Consumer Register
0x21AC	PRS_CONSUMER_TIMER4_CC1_CLR	RW	CC1 Consumer Register
0x21B0	PRS_CONSUMER_TIMER4_CC2_CLR	RW	CC2 Consumer Register
0x21B4	PRS_CONSUMER_TIMER4_DTI_CLR	RW	DTI Consumer Register
0x21B8	PRS_CONSUMER_TIMER4_DTIFS1_CLR	RW	DTI Consumer Register
0x21BC	PRS_CONSUMER_TIMER4_DTIFS2_CLR	RW	DTI Consumer Register
0x21C0	PRS_CONSUMER_USART0_CLK_CLR	RW	CLK Consumer Register
0x21C4	PRS_CONSUMER_USART0_IR_CLR	RW	IR Consumer Register
0x21C8	PRS_CONSUMER_USART0_RX_CLR	RW	RX Consumer Register
0x21CC	PRS_CONSUMER_USART0_TRIGGER_CLR	RW	TRIGGER Consumer Register
0x21DC	PRS_CONSUMER_VDAC0_ASYNCCTRIGCH0_CLR	RW	ASYNCTRIG Consumer Register
0x21E0	PRS_CONSUMER_VDAC0_ASYNCCTRIGCH1_CLR	RW	ASYNCTRIG Consumer Register
0x21E4	PRS_CONSUMER_VDAC0_SYNCCTRIGCH0_CLR	RW	SYNCTRIG Consumer Register
0x21E8	PRS_CONSUMER_VDAC0_SYNCCTRIGCH1_CLR	RW	SYNCTRIG Consumer Register

Offset	Name	Type	Description
0x21EC	PRS_CONSUMER_VDAC1_ASYNCCTRIGCH0_CLR	RW	ASYNCTRIG Consumer Register
0x21F0	PRS_CONSUMER_VDAC1_ASYNCCTRIGCH1_CLR	RW	ASYNCTRIG Consumer Register
0x21F4	PRS_CONSUMER_VDAC1_SYNCCTRIGCH0_CLR	RW	SYNCTRIG Consumer Register
0x21F8	PRS_CONSUMER_VDAC1_SYNCCTRIGCH1_CLR	RW	SYNCTRIG Consumer Register
0x21FC	PRS_CONSUMER_WDOG0_SRC0_CLR	RW	SRC0 Consumer Register
0x2200	PRS_CONSUMER_WDOG0_SRC1_CLR	RW	SRC1 Consumer Register
0x2204	PRS_CONSUMER_WDOG1_SRC0_CLR	RW	SRC0 Consumer Register
0x2208	PRS_CONSUMER_WDOG1_SRC1_CLR	RW	SRC1 Consumer Register
0x3000	PRS_IPVERSION_TGL	R	PRS IPVERSION
0x3008	PRS_ASYNC_SWPULSE_TGL	W	Software Pulse Register
0x300C	PRS_ASYNC_SWLEVEL_TGL	RW	Software Level Register
0x3010	PRS_ASYNC_PEEK_TGL	RH	Async Channel Values
0x3014	PRS_SYNC_PEEK_TGL	RH	Sync Channel Values
0x3018	PRS_ASYNC_CHx_CTRL_TGL	RW	Async Channel Control Register
0x3058	PRS_SYNC_CHx_CTRL_TGL	RW	Sync Channel Control Register
0x3068	PRS_CONSUMER_CMU_CALDN_TGL	RW	CALDN Consumer Register
0x306C	PRS_CONSUMER_CMU_CALUP_TGL	RW	CALUP Consumer Register
0x3070	PRS_CONSUMER_EU-SART0_CLK_TGL	RW	CLK Consumer Register
0x3074	PRS_CONSUMER_EU-SART0_RX_TGL	RW	RX Consumer Register
0x3078	PRS_CONSUMER_EU-SART0_TRIGGER_TGL	RW	TRIGGER Consumer Register
0x307C	PRS_CONSUMER_EU-SART1_CLK_TGL	RW	CLK Consumer Register
0x3080	PRS_CONSUMER_EU-SART1_RX_TGL	RW	RX Consumer Register
0x3084	PRS_CONSUMER_EU-SART1_TRIGGER_TGL	RW	TRIGGER Consumer Register
0x308C	PRS_CONSUMER_IADC0_SCANTRIGGER_TGL	RW	SCAN Consumer Register

Offset	Name	Type	Description
0x3090	PRS_CONSUMER_IADC0_SINGLETRIGGER_TGL	RW	SINGLE Consumer Register
0x3094	PRS_CONSUMER_LDMAXBAR_DMAREQ0_TGL	RW	DMAREQ0 Consumer Register
0x3098	PRS_CONSUMER_LDMAXBAR_DMAREQ1_TGL	RW	DMAREQ1 Consumer Register
0x309C	PRS_CONSUMER_LETIMER0_CLEAR_TGL	RW	CLEAR Consumer Register
0x30A0	PRS_CONSUMER_LETIMER0_START_TGL	RW	START Consumer Register
0x30A4	PRS_CONSUMER_LETIMER0_STOP_TGL	RW	STOP Consumer Register
0x30A8	PRS_CONSUMER_MODAL_DIN_TGL	RW	DIN Consumer Register
0x30AC	PRS_CONSUMER_MODAL_PAEN_TGL	RW	PAEN Consumer Register
0x30B0	PRS_CONSUMER_PCNT0_S0IN_TGL	RW	S0IN Consumer Register
0x30B4	PRS_CONSUMER_PCNT0_S1IN_TGL	RW	S1IN Consumer Register
0x30E4	PRS_CONSUMER_RAC_CLR_TGL	RW	CLR Consumer Register
0x30E8	PRS_CONSUMER_RAC_CTIIN0_TGL	RW	CTI Consumer Register
0x30EC	PRS_CONSUMER_RAC_CTIIN1_TGL	RW	CTI Consumer Register
0x30F0	PRS_CONSUMER_RAC_CTIIN2_TGL	RW	CTI Consumer Register
0x30F4	PRS_CONSUMER_RAC_CTIIN3_TGL	RW	CTI Consumer Register
0x30F8	PRS_CONSUMER_RAC_FORCETX_TGL	RW	FORCETX Consumer Register
0x30FC	PRS_CONSUMER_RAC_RXDIS_TGL	RW	RXDIS Consumer Register
0x3100	PRS_CONSUMER_RAC_RXEN_TGL	RW	RXEN Consumer Register
0x3104	PRS_CONSUMER_RAC_TXEN_TGL	RW	TXEN Consumer Register
0x3108	PRS_CONSUMER_SETAMPLER_TAMPERSRC25_TGL	RW	TAMPERSRC25 Consumer Register
0x310C	PRS_CONSUMER_SETAMPLER_TAMPERSRC26_TGL	RW	TAMPERSRC26 Consumer Register
0x3110	PRS_CONSUMER_SETAMPLER_TAMPERSRC27_TGL	RW	TAMPERSRC27 Consumer Register
0x3114	PRS_CONSUMER_SETAMPLER_TAMPERSRC28_TGL	RW	TAMPERSRC28 Consumer Register

Offset	Name	Type	Description
0x3118	PRS_CONSUMER_SETAMPER_TAMPERSRC29_TGL	RW	TAMPERSRC29 Consumer Register
0x311C	PRS_CONSUMER_SETAMPER_TAMPERSRC30_TGL	RW	TAMPERSRC30 Consumer Register
0x3120	PRS_CONSUMER_SETAMPER_TAMPERSRC31_TGL	RW	TAMPERSRC31 Consumer Register
0x3124	PRS_CONSUMER_SYSRTC0_IN0_TGL	RW	IN0 Consumer Register
0x3128	PRS_CONSUMER_SYSRTC0_IN1_TGL	RW	IN1 Consumer Register
0x312C	PRS_CONSUMER_HFX00_OSCREQ_TGL	RW	OSCREQ Consumer Register
0x3130	PRS_CONSUMER_HFX00_TIMEOUT_TGL	RW	TIMEOUT Consumer Register
0x3134	PRS_CONSUMER_CORE_CTIIN0_TGL	RW	CTI0 Consumer Selection
0x3138	PRS_CONSUMER_CORE_CTIIN1_TGL	RW	CTI1 Consumer Selection
0x313C	PRS_CONSUMER_CORE_CTIIN2_TGL	RW	CTI2 Consumer Selection
0x3140	PRS_CONSUMER_CORE_CTIIN3_TGL	RW	CTI3 Consumer Selection
0x3144	PRS_CONSUMER_CORE_M33RXEV_TGL	RW	M33 Consumer Selection
0x3148	PRS_CONSUMER_TIMER0_CC0_TGL	RW	CC0 Consumer Register
0x314C	PRS_CONSUMER_TIMER0_CC1_TGL	RW	CC1 Consumer Register
0x3150	PRS_CONSUMER_TIMER0_CC2_TGL	RW	CC2 Consumer Register
0x3154	PRS_CONSUMER_TIMER0_DTI_TGL	RW	DTI Consumer Register
0x3158	PRS_CONSUMER_TIMER0_DTIFS1_TGL	RW	DTI Consumer Register
0x315C	PRS_CONSUMER_TIMER0_DTIFS2_TGL	RW	DTI Consumer Register
0x3160	PRS_CONSUMER_TIMER1_CC0_TGL	RW	CC0 Consumer Register
0x3164	PRS_CONSUMER_TIMER1_CC1_TGL	RW	CC1 Consumer Register
0x3168	PRS_CONSUMER_TIMER1_CC2_TGL	RW	CC2 Consumer Register
0x316C	PRS_CONSUMER_TIMER1_DTI_TGL	RW	DTI Consumer Register
0x3170	PRS_CONSUMER_TIMER1_DTIFS1_TGL	RW	DTI Consumer Register

Offset	Name	Type	Description
0x3174	PRS_CONSUMER_TIMER1_DTIFS2_TGL	RW	DTI Consumer Register
0x3178	PRS_CONSUMER_TIMER2_CC0_TGL	RW	CC0 Consumer Register
0x317C	PRS_CONSUMER_TIMER2_CC1_TGL	RW	CC1 Consumer Register
0x3180	PRS_CONSUMER_TIMER2_CC2_TGL	RW	CC2 Consumer Register
0x3184	PRS_CONSUMER_TIMER2_DTI_TGL	RW	DTI Consumer Register
0x3188	PRS_CONSUMER_TIMER2_DTIFS1_TGL	RW	DTI Consumer Register
0x318C	PRS_CONSUMER_TIMER2_DTIFS2_TGL	RW	DTI Consumer Register
0x3190	PRS_CONSUMER_TIMER3_CC0_TGL	RW	CC0 Consumer Register
0x3194	PRS_CONSUMER_TIMER3_CC1_TGL	RW	CC1 Consumer Register
0x3198	PRS_CONSUMER_TIMER3_CC2_TGL	RW	CC2 Consumer Register
0x319C	PRS_CONSUMER_TIMER3_DTI_TGL	RW	DTI Consumer Register
0x31A0	PRS_CONSUMER_TIMER3_DTIFS1_TGL	RW	DTI Consumer Register
0x31A4	PRS_CONSUMER_TIMER3_DTIFS2_TGL	RW	DTI Consumer Register
0x31A8	PRS_CONSUMER_TIMER4_CC0_TGL	RW	CC0 Consumer Register
0x31AC	PRS_CONSUMER_TIMER4_CC1_TGL	RW	CC1 Consumer Register
0x31B0	PRS_CONSUMER_TIMER4_CC2_TGL	RW	CC2 Consumer Register
0x31B4	PRS_CONSUMER_TIMER4_DTI_TGL	RW	DTI Consumer Register
0x31B8	PRS_CONSUMER_TIMER4_DTIFS1_TGL	RW	DTI Consumer Register
0x31BC	PRS_CONSUMER_TIMER4_DTIFS2_TGL	RW	DTI Consumer Register
0x31C0	PRS_CONSUMER_USART0_CLK_TGL	RW	CLK Consumer Register
0x31C4	PRS_CONSUMER_USART0_IR_TGL	RW	IR Consumer Register
0x31C8	PRS_CONSUMER_USART0_RX_TGL	RW	RX Consumer Register
0x31CC	PRS_CONSUMER_USART0_TRIGGER_TGL	RW	TRIGGER Consumer Register

Offset	Name	Type	Description
0x31DC	PRS_CONSUMER_VDAC0_ASYNCCTRIGCH0_TGL	RW	ASYNCTRIG Consumer Register
0x31E0	PRS_CONSUMER_VDAC0_ASYNCCTRIGCH1_TGL	RW	ASYNCTRIG Consumer Register
0x31E4	PRS_CONSUMER_VDAC0_SYNCCTRIGCH0_TGL	RW	SYNCTRIG Consumer Register
0x31E8	PRS_CONSUMER_VDAC0_SYNCCTRIGCH1_TGL	RW	SYNCTRIG Consumer Register
0x31EC	PRS_CONSUMER_VDAC1_ASYNCCTRIGCH0_TGL	RW	ASYNCTRIG Consumer Register
0x31F0	PRS_CONSUMER_VDAC1_ASYNCCTRIGCH1_TGL	RW	ASYNCTRIG Consumer Register
0x31F4	PRS_CONSUMER_VDAC1_SYNCCTRIGCH0_TGL	RW	SYNCTRIG Consumer Register
0x31F8	PRS_CONSUMER_VDAC1_SYNCCTRIGCH1_TGL	RW	SYNCTRIG Consumer Register
0x31FC	PRS_CONSUMER_WDOG0_SRC0_TGL	RW	SRC0 Consumer Register
0x3200	PRS_CONSUMER_WDOG0_SRC1_TGL	RW	SRC1 Consumer Register
0x3204	PRS_CONSUMER_WDOG1_SRC0_TGL	RW	SRC0 Consumer Register
0x3208	PRS_CONSUMER_WDOG1_SRC1_TGL	RW	SRC1 Consumer Register

13.5 PRS Register Description

13.5.1 PRS_IPVERSION - PRS IPVERSION

Offset	Bit Position																															
0x000	31	30	29	28	27	26	25	24	23	22	21	20	19	18	17	16	15	14	13	12	11	10	9	8	7	6	5	4	3	2	1	0
Reset	0x3																															
Access	R																															
Name	IPVERSION																															

Bit	Name	Reset	Access	Description
31:0	IPVERSION	0x3	R	New BitField The read only IPVERSION field gives the version for this module. There may be minor software changes required for modules with different values of IPVERSION

13.5.2 PRS_ASYNC_SWPULSE - Software Pulse Register

Offset	Bit Position																																																		
0x008	31	30	29	28	27	26	25	24	23	22	21	20	19	18	17	16	15	14	13	12	11	10	9	8	7	6	5	4	3	2	1	0																			
Reset																	0x0	0x0	0x0	0x0	0x0	0x0	0x0	0x0	0x0	0x0	0x0	0x0	0x0	0x0	0x0	0x0	0x0	0x0	0x0	0x0	0x0	0x0	0x0	0x0	0x0	0x0	0x0	0x0	0x0	0x0	0x0	0x0			
Access																	W(nB)	W(nB)	W(nB)	W(nB)	W(nB)	W(nB)	W(nB)	W(nB)	W(nB)	W(nB)	W(nB)	W(nB)	W(nB)	W(nB)	W(nB)	W(nB)	W(nB)	W(nB)	W(nB)	W(nB)	W(nB)	W(nB)	W(nB)	W(nB)	W(nB)	W(nB)	W(nB)	W(nB)	W(nB)	W(nB)	W(nB)	W(nB)	W(nB)		
Name																	CH15PULSE	CH14PULSE	CH13PULSE	CH12PULSE	CH11PULSE	CH10PULSE	CH9PULSE	CH8PULSE	CH7PULSE	CH6PULSE	CH5PULSE	CH4PULSE	CH3PULSE	CH2PULSE	CH1PULSE	CH0PULSE																			

Bit	Name	Reset	Access	Description
31:16	<i>Reserved</i>	<i>To ensure compatibility with future devices, always write Reserved bits to their reset value, unless otherwise stated. More information in 1.2 Conventions</i>		
15	CH15PULSE	0x0	W(nB)	Channel pulse
14	CH14PULSE	0x0	W(nB)	Channel pulse
13	CH13PULSE	0x0	W(nB)	Channel pulse
12	CH12PULSE	0x0	W(nB)	Channel pulse
11	CH11PULSE	0x0	W(nB)	Channel pulse Channel 11 pulse generation
10	CH10PULSE	0x0	W(nB)	Channel pulse Channel 10 pulse generation
9	CH9PULSE	0x0	W(nB)	Channel pulse Channel 9 pulse generation
8	CH8PULSE	0x0	W(nB)	Channel pulse Channel 8 pulse generation
7	CH7PULSE	0x0	W(nB)	Channel pulse Channel 7 pulse generation
6	CH6PULSE	0x0	W(nB)	Channel pulse Channel 6 pulse generation
5	CH5PULSE	0x0	W(nB)	Channel pulse Channel 5 pulse generation
4	CH4PULSE	0x0	W(nB)	Channel pulse Channel 4 pulse generation
3	CH3PULSE	0x0	W(nB)	Channel pulse Channel 3 pulse generation

Bit	Name	Reset	Access	Description
2	CH2PULSE	0x0	W(nB)	Channel pulse Channel 2 pulse generation
1	CH1PULSE	0x0	W(nB)	Channel pulse Channel 1 pulse generation
0	CH0PULSE	0x0	W(nB)	Channel pulse Channel 0 pulse generation

13.5.3 PRS_ASYNC_SWLEVEL - Software Level Register

Offset	Bit Position																																																		
0x00C	31	30	29	28	27	26	25	24	23	22	21	20	19	18	17	16	15	14	13	12	11	10	9	8	7	6	5	4	3	2	1	0																			
Reset																	0x0	0x0	0x0	0x0	0x0	0x0	0x0	0x0	0x0	0x0	0x0	0x0	0x0	0x0	0x0	0x0	0x0	0x0	0x0	0x0	0x0	0x0	0x0	0x0	0x0	0x0	0x0	0x0	0x0	0x0	0x0	0x0			
Access																	RW	RW	RW	RW	RW	RW	RW	RW	RW	RW	RW	RW	RW	RW	RW	RW	RW	RW	RW	RW	RW	RW	RW	RW	RW	RW	RW	RW	RW	RW	RW	RW	RW	RW	
Name																	CH15LEVEL	CH14LEVEL	CH13LEVEL	CH12LEVEL	CH11LEVEL	CH10LEVEL	CH9LEVEL	CH8LEVEL	CH7LEVEL	CH6LEVEL	CH5LEVEL	CH4LEVEL	CH3LEVEL	CH2LEVEL	CH1LEVEL	CH0LEVEL																			

Bit	Name	Reset	Access	Description
31:16	Reserved	To ensure compatibility with future devices, always write Reserved bits to their reset value, unless otherwise stated. More information in 1.2 Conventions		
15	CH15LEVEL	0x0	RW	Channel Level
14	CH14LEVEL	0x0	RW	Channel Level
13	CH13LEVEL	0x0	RW	Channel Level
12	CH12LEVEL	0x0	RW	Channel Level
11	CH11LEVEL	0x0	RW	Channel Level Channel 11 Software Level
10	CH10LEVEL	0x0	RW	Channel Level Channel 10 Software Level
9	CH9LEVEL	0x0	RW	Channel Level Channel 9 Software Level
8	CH8LEVEL	0x0	RW	Channel Level Channel 8 Software Level
7	CH7LEVEL	0x0	RW	Channel Level Channel 7 Software Level
6	CH6LEVEL	0x0	RW	Channel Level Channel 6 Software Level
5	CH5LEVEL	0x0	RW	Channel Level Channel 5 Software Level
4	CH4LEVEL	0x0	RW	Channel Level Channel 4 Software Level
3	CH3LEVEL	0x0	RW	Channel Level Channel 3 Software Level

Bit	Name	Reset	Access	Description
2	CH2LEVEL	0x0	RW	Channel Level Channel 2 Software Level
1	CH1LEVEL	0x0	RW	Channel Level Channel 1 Software Level
0	CH0LEVEL	0x0	RW	Channel Level Channel 0 Software Level

13.5.4 PRS_ASYNC_PEEK - Async Channel Values

Offset	Bit Position																																																				
0x010	31	30	29	28	27	26	25	24	23	22	21	20	19	18	17	16	15	14	13	12	11	10	9	8	7	6	5	4	3	2	1	0																					
Reset																	0x0	0x0	0x0	0x0	0x0	0x0	0x0	0x0	0x0	0x0	0x0	0x0	0x0	0x0	0x0	0x0	0x0	0x0	0x0	0x0	0x0	0x0	0x0	0x0	0x0	0x0	0x0	0x0	0x0	0x0	0x0	0x0	0x0				
Access																	R	R	R	R	R	R	R	R	R	R	R	R	R	R	R	R	R	R	R	R	R	R	R	R	R	R	R	R	R	R	R	R	R	R	R		
Name																	CH15VAL	CH14VAL	CH13VAL	CH12VAL	CH11VAL	CH10VAL	CH9VAL	CH8VAL	CH7VAL	CH6VAL	CH5VAL	CH4VAL	CH3VAL	CH2VAL	CH1VAL	CH0VAL																					

Bit	Name	Reset	Access	Description
31:16	<i>Reserved</i>			<i>To ensure compatibility with future devices, always write Reserved bits to their reset value, unless otherwise stated. More information in 1.2 Conventions</i>
15	CH15VAL	0x0	R	Channel 15 current value
14	CH14VAL	0x0	R	Channel 14 current value
13	CH13VAL	0x0	R	Channel 13 current value
12	CH12VAL	0x0	R	Channel 12 Current Value
11	CH11VAL See bit 0.	0x0	R	Channel 11 Current Value
10	CH10VAL See bit 0.	0x0	R	Channel 10 Current Value
9	CH9VAL See bit 0.	0x0	R	Channel 9 Current Value
8	CH8VAL See bit 0.	0x0	R	Channel 8 Current Value
7	CH7VAL See bit 0.	0x0	R	Channel 7 Current Value
6	CH6VAL See bit 0.	0x0	R	Channel 6 Current Value
5	CH5VAL See bit 0.	0x0	R	Channel 5 Current Value
4	CH4VAL See bit 0.	0x0	R	Channel 4 Current Value
3	CH3VAL See bit 0.	0x0	R	Channel 3 Current Value
2	CH2VAL	0x0	R	Channel 2 Current Value

Bit	Name	Reset	Access	Description
	See bit 0.			
1	CH1VAL	0x0	R	Channel 1 Current Value See bit 0.
0	CH0VAL	0x0	R	Channel 0 Current Value Sample the current output value of channel 0. This value may be one or two clock delayed

13.5.5 PRS_SYNC_PEEK - Sync Channel Values

Offset	Bit Position																															
0x014	31	30	29	28	27	26	25	24	23	22	21	20	19	18	17	16	15	14	13	12	11	10	9	8	7	6	5	4	3	2	1	0
Reset																											0x0	0x0	0x0	0x0		
Access																											R	R	R	R		
Name																											CH3VAL	CH2VAL	CH1VAL	CH0VAL		

Bit	Name	Reset	Access	Description
31:4	<i>Reserved</i>	<i>To ensure compatibility with future devices, always write Reserved bits to their reset value, unless otherwise stated. More information in 1.2 Conventions</i>		
3	CH3VAL	0x0	R	Channel Value Channel 3 current value
2	CH2VAL	0x0	R	Channel Value Channel 2 current value
1	CH1VAL	0x0	R	Channel Value Channel 1 current value
0	CH0VAL	0x0	R	Channel Value Channel 0 current value

13.5.6 PRS_ASYNC_CHx_CTRL - Async Channel Control Register

Offset	Bit Position																															
0x018	31	30	29	28	27	26	25	24	23	22	21	20	19	18	17	16	15	14	13	12	11	10	9	8	7	6	5	4	3	2	1	0
Reset					0x0								0xC								0x0								0x0			
Access					RW								RW								RW								RW			
Name					AUXSEL								FNSEL								SOURCESEL								SIGSEL			

Bit	Name	Reset	Access	Description
31:28	<i>Reserved</i>	<i>To ensure compatibility with future devices, always write Reserved bits to their reset value, unless otherwise stated. More information in 1.2 Conventions</i>		
27:24	AUXSEL	0x0	RW	Aux Select Select Asynchronous PRS channel as input B of LUT function. Async PRS[n] is selected with AUXSEL = n.
23:20	<i>Reserved</i>	<i>To ensure compatibility with future devices, always write Reserved bits to their reset value, unless otherwise stated. More information in 1.2 Conventions</i>		
19:16	FNSEL	0xC	RW	Function Select Look up table function select. Signal A is the selected producer input. Signal B is the output of the previous PRS channel.
	Value	Mode	Description	
	0	LOGICAL_ZERO	Logical 0	
	1	A_NOR_B	A NOR B	
	2	NOT_A_AND_B	(!A) AND B	
	3	NOT_A	!A	
	4	A_AND_NOT_B	A AND (!B)	
	5	NOT_B	!B	
	6	A_XOR_B	A XOR B	
	7	A_NAND_B	A NAND B	
	8	A_AND_B	A AND B	
	9	A_XNOR_B	A XNOR B	
	10	B	B	
	11	NOT_A_OR_B	(!A) OR B	
	12	A	A	
	13	A_OR_NOT_B	A OR (!B)	
	14	A_OR_B	A OR B	
	15	LOGICAL_ONE	Logical 1	
15	<i>Reserved</i>	<i>To ensure compatibility with future devices, always write Reserved bits to their reset value, unless otherwise stated. More information in 1.2 Conventions</i>		
14:8	SOURCESEL	0x0	RW	Source Select

Bit	Name	Reset	Access	Description
				Select input source for asynchronous PRS channel. See Asynchronous Producers table for details.
7:3	<i>Reserved</i>	<i>To ensure compatibility with future devices, always write Reserved bits to their reset value, unless otherwise stated. More information in 1.2 Conventions</i>		
2:0	SIGSEL	0x0	RW	Signal Select Select signal input for asynchronous PRS channel. See Asynchronous Producers table for details.
	Value	Mode	Description	
	0	NONE		

13.5.7 PRS_SYNC_CHx_CTRL - Sync Channel Control Register

Offset	Bit Position																															
0x058	31	30	29	28	27	26	25	24	23	22	21	20	19	18	17	16	15	14	13	12	11	10	9	8	7	6	5	4	3	2	1	0
Reset																0x0																
Access																RW								RW								
Name																SOURCESEL								SIGSEL								

Bit	Name	Reset	Access	Description
31:15	<i>Reserved</i>	<i>To ensure compatibility with future devices, always write Reserved bits to their reset value, unless otherwise stated. More information in 1.2 Conventions</i>		
14:8	SOURCESEL	0x0	RW	Source Select Select input source to sync PRS channel.
7:3	<i>Reserved</i>	<i>To ensure compatibility with future devices, always write Reserved bits to their reset value, unless otherwise stated. More information in 1.2 Conventions</i>		
2:0	SIGSEL	0x0	RW	Signal Select Select signal input to sync PRS channel.
	Value	Mode	Description	
	0	NONE		

13.5.8 PRS_CONSUMER_CMU_CALDN - CALDN Consumer Register

Offset	Bit Position																															
0x068	31	30	29	28	27	26	25	24	23	22	21	20	19	18	17	16	15	14	13	12	11	10	9	8	7	6	5	4	3	2	1	0
Reset																											PRSEL		0x0			
Access																											RW					
Name																											PRSEL					

Bit	Name	Reset	Access	Description
31:4	Reserved			To ensure compatibility with future devices, always write Reserved bits to their reset value, unless otherwise stated. More information in 1.2 Conventions
3:0	PRSEL CALDN async channel select	0x0	RW	CALDN async channel select

13.5.9 PRS_CONSUMER_CMU_CALUP - CALUP Consumer Register

Offset	Bit Position																															
0x06C	31	30	29	28	27	26	25	24	23	22	21	20	19	18	17	16	15	14	13	12	11	10	9	8	7	6	5	4	3	2	1	0
Reset																											PRSEL		0x0			
Access																											RW					
Name																											PRSEL					

Bit	Name	Reset	Access	Description
31:4	Reserved			To ensure compatibility with future devices, always write Reserved bits to their reset value, unless otherwise stated. More information in 1.2 Conventions
3:0	PRSEL CALUP async channel select	0x0	RW	CALUP async channel select

13.5.10 PRS_CONSUMER_EUSART0_CLK - CLK Consumer Register

Offset	Bit Position																															
0x070	31	30	29	28	27	26	25	24	23	22	21	20	19	18	17	16	15	14	13	12	11	10	9	8	7	6	5	4	3	2	1	0
Reset																											PRSEL		0x0			
Access																											RW					
Name																											PRSEL					

Bit	Name	Reset	Access	Description
31:4	Reserved	To ensure compatibility with future devices, always write Reserved bits to their reset value, unless otherwise stated. More information in 1.2 Conventions		
3:0	PRSEL CLK async channel select	0x0	RW	CLK async channel select

13.5.11 PRS_CONSUMER_EUSART0_RX - RX Consumer Register

Offset	Bit Position																															
0x074	31	30	29	28	27	26	25	24	23	22	21	20	19	18	17	16	15	14	13	12	11	10	9	8	7	6	5	4	3	2	1	0
Reset																											PRSEL		0x0			
Access																											RW					
Name																											PRSEL					

Bit	Name	Reset	Access	Description
31:4	Reserved	To ensure compatibility with future devices, always write Reserved bits to their reset value, unless otherwise stated. More information in 1.2 Conventions		
3:0	PRSEL RX async channel select	0x0	RW	RX async channel select

13.5.12 PRS_CONSUMER_EUSART0_TRIGGER - TRIGGER Consumer Register

Offset	Bit Position																															
0x078	31	30	29	28	27	26	25	24	23	22	21	20	19	18	17	16	15	14	13	12	11	10	9	8	7	6	5	4	3	2	1	0
Reset																											PRSEL		0x0			
Access																											PRSEL		RW			
Name																											PRSEL					

Bit	Name	Reset	Access	Description
31:4	Reserved	To ensure compatibility with future devices, always write Reserved bits to their reset value, unless otherwise stated. More information in 1.2 Conventions		
3:0	PRSEL	0x0	RW	TRIGGER async channel select TRIGGER async channel select

13.5.13 PRS_CONSUMER_EUSART1_CLK - CLK Consumer Register

Offset	Bit Position																															
0x07C	31	30	29	28	27	26	25	24	23	22	21	20	19	18	17	16	15	14	13	12	11	10	9	8	7	6	5	4	3	2	1	0
Reset																											PRSEL		0x0			
Access																											PRSEL		RW			
Name																											PRSEL					

Bit	Name	Reset	Access	Description
31:4	Reserved	To ensure compatibility with future devices, always write Reserved bits to their reset value, unless otherwise stated. More information in 1.2 Conventions		
3:0	PRSEL	0x0	RW	CLK async channel select CLK async channel select

13.5.14 PRS_CONSUMER_EUSART1_RX - RX Consumer Register

Offset	Bit Position																															
0x080	31	30	29	28	27	26	25	24	23	22	21	20	19	18	17	16	15	14	13	12	11	10	9	8	7	6	5	4	3	2	1	0
Reset																											PRSEL		0x0			
Access																											RW					
Name																											PRSEL					

Bit	Name	Reset	Access	Description
31:4	Reserved	To ensure compatibility with future devices, always write Reserved bits to their reset value, unless otherwise stated. More information in 1.2 Conventions		
3:0	PRSEL RX async channel select	0x0	RW	RX async channel select

13.5.15 PRS_CONSUMER_EUSART1_TRIGGER - TRIGGER Consumer Register

Offset	Bit Position																															
0x084	31	30	29	28	27	26	25	24	23	22	21	20	19	18	17	16	15	14	13	12	11	10	9	8	7	6	5	4	3	2	1	0
Reset																											PRSEL		0x0			
Access																											RW					
Name																											PRSEL					

Bit	Name	Reset	Access	Description
31:4	Reserved	To ensure compatibility with future devices, always write Reserved bits to their reset value, unless otherwise stated. More information in 1.2 Conventions		
3:0	PRSEL TRIGGER async channel select	0x0	RW	TRIGGER async channel select

13.5.16 PRS_CONSUMER_IADC0_SCANTRIGGER - SCAN Consumer Register

Offset	Bit Position																																							
0x08C	31	30	29	28	27	26	25	24	23	22	21	20	19	18	17	16	15	14	13	12	11	10	9	8	7	6	5	4	3	2	1	0								
Reset																							0x0						0x0											
Access																							RW						RW											
Name																							SPRSSEL												PRRSEL					

Bit	Name	Reset	Access	Description
31:10	Reserved			To ensure compatibility with future devices, always write Reserved bits to their reset value, unless otherwise stated. More information in 1.2 Conventions
9:8	SPRSSEL	0x0	RW	SCAN sync channel select SCAN sync channel select
7:4	Reserved			To ensure compatibility with future devices, always write Reserved bits to their reset value, unless otherwise stated. More information in 1.2 Conventions
3:0	PRRSEL	0x0	RW	SCAN async channel select SCAN async channel select

13.5.17 PRS_CONSUMER_IADC0_SINGLETRIGGER - SINGLE Consumer Register

Offset	Bit Position																																							
0x090	31	30	29	28	27	26	25	24	23	22	21	20	19	18	17	16	15	14	13	12	11	10	9	8	7	6	5	4	3	2	1	0								
Reset																							0x0						0x0											
Access																							RW						RW											
Name																							SPRSSEL												PRRSEL					

Bit	Name	Reset	Access	Description
31:10	Reserved			To ensure compatibility with future devices, always write Reserved bits to their reset value, unless otherwise stated. More information in 1.2 Conventions
9:8	SPRSSEL	0x0	RW	SINGLE sync channel select SINGLE sync channel select
7:4	Reserved			To ensure compatibility with future devices, always write Reserved bits to their reset value, unless otherwise stated. More information in 1.2 Conventions
3:0	PRRSEL	0x0	RW	SINGLE async channel select SINGLE async channel select

13.5.18 PRS_CONSUMER_LDMAXBAR_DMAREQ0 - DMAREQ0 Consumer Register

Offset	Bit Position																															
0x094	31	30	29	28	27	26	25	24	23	22	21	20	19	18	17	16	15	14	13	12	11	10	9	8	7	6	5	4	3	2	1	0
Reset																											PRSEL		0x0			
Access																											RW					
Name																											PRSEL					

Bit	Name	Reset	Access	Description
31:4	Reserved	To ensure compatibility with future devices, always write Reserved bits to their reset value, unless otherwise stated. More information in 1.2 Conventions		
3:0	PRSEL	0x0	RW	DMAREQ0 async channel select DMAREQ0 async channel select

13.5.19 PRS_CONSUMER_LDMAXBAR_DMAREQ1 - DMAREQ1 Consumer Register

Offset	Bit Position																															
0x098	31	30	29	28	27	26	25	24	23	22	21	20	19	18	17	16	15	14	13	12	11	10	9	8	7	6	5	4	3	2	1	0
Reset																											PRSEL		0x0			
Access																											RW					
Name																											PRSEL					

Bit	Name	Reset	Access	Description
31:4	Reserved	To ensure compatibility with future devices, always write Reserved bits to their reset value, unless otherwise stated. More information in 1.2 Conventions		
3:0	PRSEL	0x0	RW	DMAREQ1 async channel select DMAREQ1 async channel select

13.5.20 PRS_CONSUMER_LETIMER0_CLEAR - CLEAR Consumer Register

Offset	Bit Position																															
0x09C	31	30	29	28	27	26	25	24	23	22	21	20	19	18	17	16	15	14	13	12	11	10	9	8	7	6	5	4	3	2	1	0
Reset																												PRSEL		0x0		
Access																												PRSEL		RW		
Name																												PRSEL				

Bit	Name	Reset	Access	Description
31:4	Reserved	To ensure compatibility with future devices, always write Reserved bits to their reset value, unless otherwise stated. More information in 1.2 Conventions		
3:0	PRSEL CLEAR async channel select	0x0	RW	CLEAR async channel select

13.5.21 PRS_CONSUMER_LETIMER0_START - START Consumer Register

Offset	Bit Position																															
0x0A0	31	30	29	28	27	26	25	24	23	22	21	20	19	18	17	16	15	14	13	12	11	10	9	8	7	6	5	4	3	2	1	0
Reset																												PRSEL		0x0		
Access																												PRSEL		RW		
Name																												PRSEL				

Bit	Name	Reset	Access	Description
31:4	Reserved	To ensure compatibility with future devices, always write Reserved bits to their reset value, unless otherwise stated. More information in 1.2 Conventions		
3:0	PRSEL START async channel select	0x0	RW	START async channel select

13.5.22 PRS_CONSUMER_LETIMER0_STOP - STOP Consumer Register

Offset	Bit Position																															
0x0A4	31	30	29	28	27	26	25	24	23	22	21	20	19	18	17	16	15	14	13	12	11	10	9	8	7	6	5	4	3	2	1	0
Reset																											0x0					
Access																											RW					
Name																											PRSEL					

Bit	Name	Reset	Access	Description
31:4	Reserved	To ensure compatibility with future devices, always write Reserved bits to their reset value, unless otherwise stated. More information in 1.2 Conventions		
3:0	PRSEL STOP async channel select	0x0	RW	STOP async channel select

13.5.23 PRS_CONSUMER_MODEM_DIN - DIN Consumer Register

Offset	Bit Position																															
0x0A8	31	30	29	28	27	26	25	24	23	22	21	20	19	18	17	16	15	14	13	12	11	10	9	8	7	6	5	4	3	2	1	0
Reset																											0x0					
Access																											RW					
Name																											PRSEL					

Bit	Name	Reset	Access	Description
31:4	Reserved	To ensure compatibility with future devices, always write Reserved bits to their reset value, unless otherwise stated. More information in 1.2 Conventions		
3:0	PRSEL DIN async channel select	0x0	RW	DIN async channel select

13.5.24 PRS_CONSUMER_MODEM_PAEN - PAEN Consumer Register

Offset	Bit Position																															
0x0AC	31	30	29	28	27	26	25	24	23	22	21	20	19	18	17	16	15	14	13	12	11	10	9	8	7	6	5	4	3	2	1	0
Reset																											PRSEL		0x0			
Access																											RW					
Name																											PRSEL					

Bit	Name	Reset	Access	Description
31:4	Reserved			To ensure compatibility with future devices, always write Reserved bits to their reset value, unless otherwise stated. More information in 1.2 Conventions
3:0	PRSEL	0x0	RW	PAEN async channel select PAEN async channel select

13.5.25 PRS_CONSUMER_PCNT0_S0IN - S0IN Consumer Register

Offset	Bit Position																															
0x0B0	31	30	29	28	27	26	25	24	23	22	21	20	19	18	17	16	15	14	13	12	11	10	9	8	7	6	5	4	3	2	1	0
Reset																											PRSEL		0x0			
Access																											RW					
Name																											PRSEL					

Bit	Name	Reset	Access	Description
31:4	Reserved			To ensure compatibility with future devices, always write Reserved bits to their reset value, unless otherwise stated. More information in 1.2 Conventions
3:0	PRSEL	0x0	RW	S0IN async channel select S0IN async channel select

13.5.26 PRS_CONSUMER_PCNT0_S1IN - S1IN Consumer Register

Offset	Bit Position																															
0x0B4	31	30	29	28	27	26	25	24	23	22	21	20	19	18	17	16	15	14	13	12	11	10	9	8	7	6	5	4	3	2	1	0
Reset																											0x0					
Access																											RW					
Name																											PRSEL					

Bit	Name	Reset	Access	Description
31:4	Reserved			To ensure compatibility with future devices, always write Reserved bits to their reset value, unless otherwise stated. More information in 1.2 Conventions
3:0	PRSEL	0x0	RW	S1IN async channel select S1IN async channel select

13.5.27 PRS_CONSUMER_RAC_CLR - CLR Consumer Register

Offset	Bit Position																															
0x0E4	31	30	29	28	27	26	25	24	23	22	21	20	19	18	17	16	15	14	13	12	11	10	9	8	7	6	5	4	3	2	1	0
Reset																											0x0					
Access																											RW					
Name																											PRSEL					

Bit	Name	Reset	Access	Description
31:4	Reserved			To ensure compatibility with future devices, always write Reserved bits to their reset value, unless otherwise stated. More information in 1.2 Conventions
3:0	PRSEL	0x0	RW	CLR async channel select CLR async channel select

13.5.28 PRS_CONSUMER_RAC_CTIIN0 - CTI Consumer Register

Offset	Bit Position																															
0x0E8	31	30	29	28	27	26	25	24	23	22	21	20	19	18	17	16	15	14	13	12	11	10	9	8	7	6	5	4	3	2	1	0
Reset																											PRSEL		0x0			
Access																											RW					
Name																											PRSEL					

Bit	Name	Reset	Access	Description
31:4	Reserved			To ensure compatibility with future devices, always write Reserved bits to their reset value, unless otherwise stated. More information in 1.2 Conventions
3:0	PRSEL CTI async channel select	0x0	RW	CTI async channel select

13.5.29 PRS_CONSUMER_RAC_CTIIN1 - CTI Consumer Register

Offset	Bit Position																															
0x0EC	31	30	29	28	27	26	25	24	23	22	21	20	19	18	17	16	15	14	13	12	11	10	9	8	7	6	5	4	3	2	1	0
Reset																											PRSEL		0x0			
Access																											RW					
Name																											PRSEL					

Bit	Name	Reset	Access	Description
31:4	Reserved			To ensure compatibility with future devices, always write Reserved bits to their reset value, unless otherwise stated. More information in 1.2 Conventions
3:0	PRSEL CTI async channel select	0x0	RW	CTI async channel select

13.5.30 PRS_CONSUMER_RAC_CTIIN2 - CTI Consumer Register

Offset	Bit Position																															
0x0F0	31	30	29	28	27	26	25	24	23	22	21	20	19	18	17	16	15	14	13	12	11	10	9	8	7	6	5	4	3	2	1	0
Reset																											PRSEL		0x0			
Access																											RW					
Name																											PRSEL					

Bit	Name	Reset	Access	Description
31:4	Reserved	To ensure compatibility with future devices, always write Reserved bits to their reset value, unless otherwise stated. More information in 1.2 Conventions		
3:0	PRSEL CTI async channel select	0x0	RW	CTI async channel select

13.5.31 PRS_CONSUMER_RAC_CTIIN3 - CTI Consumer Register

Offset	Bit Position																															
0x0F4	31	30	29	28	27	26	25	24	23	22	21	20	19	18	17	16	15	14	13	12	11	10	9	8	7	6	5	4	3	2	1	0
Reset																											PRSEL		0x0			
Access																											RW					
Name																											PRSEL					

Bit	Name	Reset	Access	Description
31:4	Reserved	To ensure compatibility with future devices, always write Reserved bits to their reset value, unless otherwise stated. More information in 1.2 Conventions		
3:0	PRSEL CTI async channel select	0x0	RW	CTI async channel select

13.5.32 PRS_CONSUMER_RAC_FORCETX - FORCETX Consumer Register

Offset	Bit Position																															
0x0F8	31	30	29	28	27	26	25	24	23	22	21	20	19	18	17	16	15	14	13	12	11	10	9	8	7	6	5	4	3	2	1	0
Reset																											PRSEL		0x0			
Access																											RW					
Name																											PRSEL					

Bit	Name	Reset	Access	Description
31:4	Reserved	To ensure compatibility with future devices, always write Reserved bits to their reset value, unless otherwise stated. More information in 1.2 Conventions		
3:0	PRSEL FORCETX async channel select	0x0	RW	FORCETX async channel select

13.5.33 PRS_CONSUMER_RAC_RXDIS - RXDIS Consumer Register

Offset	Bit Position																															
0x0FC	31	30	29	28	27	26	25	24	23	22	21	20	19	18	17	16	15	14	13	12	11	10	9	8	7	6	5	4	3	2	1	0
Reset																											PRSEL		0x0			
Access																											RW					
Name																											PRSEL					

Bit	Name	Reset	Access	Description
31:4	Reserved	To ensure compatibility with future devices, always write Reserved bits to their reset value, unless otherwise stated. More information in 1.2 Conventions		
3:0	PRSEL RXDIS async channel select	0x0	RW	RXDIS async channel select

13.5.34 PRS_CONSUMER_RAC_RXEN - RXEN Consumer Register

Offset	Bit Position																															
0x100	31	30	29	28	27	26	25	24	23	22	21	20	19	18	17	16	15	14	13	12	11	10	9	8	7	6	5	4	3	2	1	0
Reset																											0x0					
Access																											RW					
Name																											PRSSEL					

Bit	Name	Reset	Access	Description
31:4	<i>Reserved</i>			<i>To ensure compatibility with future devices, always write Reserved bits to their reset value, unless otherwise stated. More information in 1.2 Conventions</i>
3:0	PRSSEL	0x0	RW	RXEN async channel select RXEN async channel select

13.5.35 PRS_CONSUMER_RAC_TXEN - TXEN Consumer Register

Offset	Bit Position																															
0x104	31	30	29	28	27	26	25	24	23	22	21	20	19	18	17	16	15	14	13	12	11	10	9	8	7	6	5	4	3	2	1	0
Reset																											0x0					
Access																											RW					
Name																											PRSSEL					

Bit	Name	Reset	Access	Description
31:4	<i>Reserved</i>			<i>To ensure compatibility with future devices, always write Reserved bits to their reset value, unless otherwise stated. More information in 1.2 Conventions</i>
3:0	PRSSEL	0x0	RW	TXEN async channel select TXEN async channel select

13.5.36 PRS_CONSUMER_SETAMPER_TAMPERSRC25 - TAMPERSRC25 Consumer Register

Offset	Bit Position																															
0x108	31	30	29	28	27	26	25	24	23	22	21	20	19	18	17	16	15	14	13	12	11	10	9	8	7	6	5	4	3	2	1	0
Reset																											PRSEL		0x0			
Access																											PRSEL		RW			
Name																											PRSEL					

Bit	Name	Reset	Access	Description
31:4	Reserved	To ensure compatibility with future devices, always write Reserved bits to their reset value, unless otherwise stated. More information in 1.2 Conventions		
3:0	PRSEL	0x0	RW	TAMPERSRC25 async channel select TAMPERSRC25 async channel select

13.5.37 PRS_CONSUMER_SETAMPER_TAMPERSRC26 - TAMPERSRC26 Consumer Register

Offset	Bit Position																															
0x10C	31	30	29	28	27	26	25	24	23	22	21	20	19	18	17	16	15	14	13	12	11	10	9	8	7	6	5	4	3	2	1	0
Reset																											PRSEL		0x0			
Access																											PRSEL		RW			
Name																											PRSEL					

Bit	Name	Reset	Access	Description
31:4	Reserved	To ensure compatibility with future devices, always write Reserved bits to their reset value, unless otherwise stated. More information in 1.2 Conventions		
3:0	PRSEL	0x0	RW	TAMPERSRC26 async channel select TAMPERSRC26 async channel select

13.5.38 PRS_CONSUMER_SETAMPER_TAMPERSRC27 - TAMPERSRC27 Consumer Register

Offset	Bit Position																															
0x110	31	30	29	28	27	26	25	24	23	22	21	20	19	18	17	16	15	14	13	12	11	10	9	8	7	6	5	4	3	2	1	0
Reset																											PRSEL		0x0			
Access																											PRSEL		RW			
Name																											PRSEL					

Bit	Name	Reset	Access	Description
31:4	Reserved	To ensure compatibility with future devices, always write Reserved bits to their reset value, unless otherwise stated. More information in 1.2 Conventions		
3:0	PRSEL	0x0	RW	TAMPERSRC27 async channel select TAMPERSRC27 async channel select

13.5.39 PRS_CONSUMER_SETAMPER_TAMPERSRC28 - TAMPERSRC28 Consumer Register

Offset	Bit Position																															
0x114	31	30	29	28	27	26	25	24	23	22	21	20	19	18	17	16	15	14	13	12	11	10	9	8	7	6	5	4	3	2	1	0
Reset																											PRSEL		0x0			
Access																											PRSEL		RW			
Name																											PRSEL					

Bit	Name	Reset	Access	Description
31:4	Reserved	To ensure compatibility with future devices, always write Reserved bits to their reset value, unless otherwise stated. More information in 1.2 Conventions		
3:0	PRSEL	0x0	RW	TAMPERSRC28 async channel select TAMPERSRC28 async channel select

13.5.40 PRS_CONSUMER_SETAMPER_TAMPERSRC29 - TAMPERSRC29 Consumer Register

Offset	Bit Position																															
0x118	31	30	29	28	27	26	25	24	23	22	21	20	19	18	17	16	15	14	13	12	11	10	9	8	7	6	5	4	3	2	1	0
Reset																											PRSEL		0x0			
Access																											PRSEL		RW			
Name																											PRSEL					

Bit	Name	Reset	Access	Description
31:4	Reserved	To ensure compatibility with future devices, always write Reserved bits to their reset value, unless otherwise stated. More information in 1.2 Conventions		
3:0	PRSEL	0x0	RW	TAMPERSRC29 async channel select TAMPERSRC29 async channel select

13.5.41 PRS_CONSUMER_SETAMPER_TAMPERSRC30 - TAMPERSRC30 Consumer Register

Offset	Bit Position																															
0x11C	31	30	29	28	27	26	25	24	23	22	21	20	19	18	17	16	15	14	13	12	11	10	9	8	7	6	5	4	3	2	1	0
Reset																											PRSEL		0x0			
Access																											PRSEL		RW			
Name																											PRSEL					

Bit	Name	Reset	Access	Description
31:4	Reserved	To ensure compatibility with future devices, always write Reserved bits to their reset value, unless otherwise stated. More information in 1.2 Conventions		
3:0	PRSEL	0x0	RW	TAMPERSRC30 async channel select TAMPERSRC30 async channel select

13.5.42 PRS_CONSUMER_SETAMPER_TAMPERSRC31 - TAMPERSRC31 Consumer Register

Offset	Bit Position																															
0x120	31	30	29	28	27	26	25	24	23	22	21	20	19	18	17	16	15	14	13	12	11	10	9	8	7	6	5	4	3	2	1	0
Reset																											PRSEL		0x0			
Access																											PRSEL		RW			
Name																											PRSEL					

Bit	Name	Reset	Access	Description
31:4	Reserved	To ensure compatibility with future devices, always write Reserved bits to their reset value, unless otherwise stated. More information in 1.2 Conventions		
3:0	PRSEL TAMPERSRC31 async channel select	0x0	RW	TAMPERSRC31 async channel select

13.5.43 PRS_CONSUMER_SYSRTC0_IN0 - IN0 Consumer Register

Offset	Bit Position																															
0x124	31	30	29	28	27	26	25	24	23	22	21	20	19	18	17	16	15	14	13	12	11	10	9	8	7	6	5	4	3	2	1	0
Reset																											PRSEL		0x0			
Access																											PRSEL		RW			
Name																											PRSEL					

Bit	Name	Reset	Access	Description
31:4	Reserved	To ensure compatibility with future devices, always write Reserved bits to their reset value, unless otherwise stated. More information in 1.2 Conventions		
3:0	PRSEL IN0 async channel select	0x0	RW	IN0 async channel select

13.5.44 PRS_CONSUMER_SYSRTC0_IN1 - IN1 Consumer Register

Offset	Bit Position																															
0x128	31	30	29	28	27	26	25	24	23	22	21	20	19	18	17	16	15	14	13	12	11	10	9	8	7	6	5	4	3	2	1	0
Reset																														0x0		
Access																														RW		
Name																														PRSSEL		

Bit	Name	Reset	Access	Description
31:4	Reserved	To ensure compatibility with future devices, always write Reserved bits to their reset value, unless otherwise stated. More information in 1.2 Conventions		
3:0	PRSSEL IN1 async channel select	0x0	RW	IN1 async channel select

13.5.45 PRS_CONSUMER_HFX00_OSCREQ - OSCREQ Consumer Register

Offset	Bit Position																															
0x12C	31	30	29	28	27	26	25	24	23	22	21	20	19	18	17	16	15	14	13	12	11	10	9	8	7	6	5	4	3	2	1	0
Reset																														0x0		
Access																														RW		
Name																														PRSSEL		

Bit	Name	Reset	Access	Description
31:4	Reserved	To ensure compatibility with future devices, always write Reserved bits to their reset value, unless otherwise stated. More information in 1.2 Conventions		
3:0	PRSSEL OSC async channel select	0x0	RW	OSC async channel select

13.5.46 PRS_CONSUMER_HFX00_TIMEOUT - TIMEOUT Consumer Register

Offset	Bit Position																															
0x130	31	30	29	28	27	26	25	24	23	22	21	20	19	18	17	16	15	14	13	12	11	10	9	8	7	6	5	4	3	2	1	0
Reset																													0x0	0		
Access																													RW			
Name																													PRSEL			

Bit	Name	Reset	Access	Description
31:4	Reserved	<i>To ensure compatibility with future devices, always write Reserved bits to their reset value, unless otherwise stated. More information in 1.2 Conventions</i>		
3:0	PRSEL	0x0	RW	TIMEOUT async channel select TIMEOUT async channel select

13.5.47 PRS_CONSUMER_CORE_CTIIN0 - CTI0 Consumer Selection

Offset	Bit Position																															
0x134	31	30	29	28	27	26	25	24	23	22	21	20	19	18	17	16	15	14	13	12	11	10	9	8	7	6	5	4	3	2	1	0
Reset																													0x0	0		
Access																													RW			
Name																													PRSEL			

Bit	Name	Reset	Access	Description
31:4	Reserved	<i>To ensure compatibility with future devices, always write Reserved bits to their reset value, unless otherwise stated. More information in 1.2 Conventions</i>		
3:0	PRSEL	0x0	RW	CTI async channel select CTI async channel select

13.5.48 PRS_CONSUMER_CORE_CTIIN1 - CTI1 Consumer Selection

Offset	Bit Position																															
0x138	31	30	29	28	27	26	25	24	23	22	21	20	19	18	17	16	15	14	13	12	11	10	9	8	7	6	5	4	3	2	1	0
Reset																											PRSEL		0x0			
Access																											RW					
Name																											PRSEL					

Bit	Name	Reset	Access	Description
31:4	Reserved	To ensure compatibility with future devices, always write Reserved bits to their reset value, unless otherwise stated. More information in 1.2 Conventions		
3:0	PRSEL CTI async channel select	0x0	RW	CTI async channel select

13.5.49 PRS_CONSUMER_CORE_CTIIN2 - CTI2 Consumer Selection

Offset	Bit Position																															
0x13C	31	30	29	28	27	26	25	24	23	22	21	20	19	18	17	16	15	14	13	12	11	10	9	8	7	6	5	4	3	2	1	0
Reset																											PRSEL		0x0			
Access																											RW					
Name																											PRSEL					

Bit	Name	Reset	Access	Description
31:4	Reserved	To ensure compatibility with future devices, always write Reserved bits to their reset value, unless otherwise stated. More information in 1.2 Conventions		
3:0	PRSEL CTI async channel select	0x0	RW	CTI async channel select

13.5.50 PRS_CONSUMER_CORE_CTIIN3 - CTI3 Consumer Selection

Offset	Bit Position																															
0x140	31	30	29	28	27	26	25	24	23	22	21	20	19	18	17	16	15	14	13	12	11	10	9	8	7	6	5	4	3	2	1	0
Reset																											PRSEL		0x0			
Access																											RW					
Name																											PRSEL					

Bit	Name	Reset	Access	Description
31:4	Reserved	To ensure compatibility with future devices, always write Reserved bits to their reset value, unless otherwise stated. More information in 1.2 Conventions		
3:0	PRSEL CTI async channel select	0x0	RW	CTI async channel select

13.5.51 PRS_CONSUMER_CORE_M33RXEV - M33 Consumer Selection

Offset	Bit Position																															
0x144	31	30	29	28	27	26	25	24	23	22	21	20	19	18	17	16	15	14	13	12	11	10	9	8	7	6	5	4	3	2	1	0
Reset																											PRSEL		0x0			
Access																											RW					
Name																											PRSEL					

Bit	Name	Reset	Access	Description
31:4	Reserved	To ensure compatibility with future devices, always write Reserved bits to their reset value, unless otherwise stated. More information in 1.2 Conventions		
3:0	PRSEL M33 async channel select	0x0	RW	M33 async channel select

13.5.52 PRS_CONSUMER_TIMER0_CC0 - CC0 Consumer Register

Offset	Bit Position																																							
0x148	31	30	29	28	27	26	25	24	23	22	21	20	19	18	17	16	15	14	13	12	11	10	9	8	7	6	5	4	3	2	1	0								
Reset																							0x0						0x0											
Access																							RW						RW											
Name																							SPRSSEL												PRRSEL					

Bit	Name	Reset	Access	Description
31:10	Reserved	To ensure compatibility with future devices, always write Reserved bits to their reset value, unless otherwise stated. More information in 1.2 Conventions		
9:8	SPRSSEL CC0 sync channel select	0x0	RW	CC0 sync channel select
7:4	Reserved	To ensure compatibility with future devices, always write Reserved bits to their reset value, unless otherwise stated. More information in 1.2 Conventions		
3:0	PRRSEL CC0 async channel select	0x0	RW	CC0 async channel select

13.5.53 PRS_CONSUMER_TIMER0_CC1 - CC1 Consumer Register

Offset	Bit Position																																							
0x14C	31	30	29	28	27	26	25	24	23	22	21	20	19	18	17	16	15	14	13	12	11	10	9	8	7	6	5	4	3	2	1	0								
Reset																							0x0						0x0											
Access																							RW						RW											
Name																							SPRSSEL												PRRSEL					

Bit	Name	Reset	Access	Description
31:10	Reserved	To ensure compatibility with future devices, always write Reserved bits to their reset value, unless otherwise stated. More information in 1.2 Conventions		
9:8	SPRSSEL CC1 sync channel select	0x0	RW	CC1 sync channel select
7:4	Reserved	To ensure compatibility with future devices, always write Reserved bits to their reset value, unless otherwise stated. More information in 1.2 Conventions		
3:0	PRRSEL CC1 async channel select	0x0	RW	CC1 async channel select

13.5.54 PRS_CONSUMER_TIMER0_CC2 - CC2 Consumer Register

Offset	Bit Position																																					
0x150	31	30	29	28	27	26	25	24	23	22	21	20	19	18	17	16	15	14	13	12	11	10	9	8	7	6	5	4	3	2	1	0						
Reset																							0x0											0x0				
Access																							RW											RW				
Name																							SPRSSEL										PRRSSEL					

Bit	Name	Reset	Access	Description
31:10	Reserved	To ensure compatibility with future devices, always write Reserved bits to their reset value, unless otherwise stated. More information in 1.2 Conventions		
9:8	SPRSSEL CC2 sync channel select	0x0	RW	CC2 sync channel select
7:4	Reserved	To ensure compatibility with future devices, always write Reserved bits to their reset value, unless otherwise stated. More information in 1.2 Conventions		
3:0	PRRSSEL CC2 async channel select	0x0	RW	CC2 async channel select

13.5.55 PRS_CONSUMER_TIMER0_DTI - DTI Consumer Register

Offset	Bit Position																																				
0x154	31	30	29	28	27	26	25	24	23	22	21	20	19	18	17	16	15	14	13	12	11	10	9	8	7	6	5	4	3	2	1	0					
Reset																																	0x0				
Access																																	RW				
Name																																	PRRSSEL				

Bit	Name	Reset	Access	Description
31:4	Reserved	To ensure compatibility with future devices, always write Reserved bits to their reset value, unless otherwise stated. More information in 1.2 Conventions		
3:0	PRRSSEL DTI async channel select	0x0	RW	DTI async channel select

13.5.56 PRS_CONSUMER_TIMER0_DTIFS1 - DTI Consumer Register

Offset	Bit Position																															
0x158	31	30	29	28	27	26	25	24	23	22	21	20	19	18	17	16	15	14	13	12	11	10	9	8	7	6	5	4	3	2	1	0
Reset																											PRSEL		0x0			
Access																											RW					
Name																											PRSEL					

Bit	Name	Reset	Access	Description
31:4	Reserved	To ensure compatibility with future devices, always write Reserved bits to their reset value, unless otherwise stated. More information in 1.2 Conventions		
3:0	PRSEL DTI async channel select	0x0	RW	DTI async channel select

13.5.57 PRS_CONSUMER_TIMER0_DTIFS2 - DTI Consumer Register

Offset	Bit Position																															
0x15C	31	30	29	28	27	26	25	24	23	22	21	20	19	18	17	16	15	14	13	12	11	10	9	8	7	6	5	4	3	2	1	0
Reset																											PRSEL		0x0			
Access																											RW					
Name																											PRSEL					

Bit	Name	Reset	Access	Description
31:4	Reserved	To ensure compatibility with future devices, always write Reserved bits to their reset value, unless otherwise stated. More information in 1.2 Conventions		
3:0	PRSEL DTI async channel select	0x0	RW	DTI async channel select

13.5.58 PRS_CONSUMER_TIMER1_CC0 - CC0 Consumer Register

Offset	Bit Position																																										
0x160	31	30	29	28	27	26	25	24	23	22	21	20	19	18	17	16	15	14	13	12	11	10	9	8	7	6	5	4	3	2	1	0											
Reset																							0x0							0x0													
Access																							RW							RW													
Name																							SPRSSEL														PRRSSEL						

Bit	Name	Reset	Access	Description
31:10	Reserved			To ensure compatibility with future devices, always write Reserved bits to their reset value, unless otherwise stated. More information in 1.2 Conventions
9:8	SPRSSEL CC0 sync channel select	0x0	RW	CC0 sync channel select
7:4	Reserved			To ensure compatibility with future devices, always write Reserved bits to their reset value, unless otherwise stated. More information in 1.2 Conventions
3:0	PRRSSEL CC0 async channel select	0x0	RW	CC0 async channel select

13.5.59 PRS_CONSUMER_TIMER1_CC1 - CC1 Consumer Register

Offset	Bit Position																																										
0x164	31	30	29	28	27	26	25	24	23	22	21	20	19	18	17	16	15	14	13	12	11	10	9	8	7	6	5	4	3	2	1	0											
Reset																							0x0							0x0													
Access																							RW							RW													
Name																							SPRSSEL														PRRSSEL						

Bit	Name	Reset	Access	Description
31:10	Reserved			To ensure compatibility with future devices, always write Reserved bits to their reset value, unless otherwise stated. More information in 1.2 Conventions
9:8	SPRSSEL CC1 sync channel select	0x0	RW	CC1 sync channel select
7:4	Reserved			To ensure compatibility with future devices, always write Reserved bits to their reset value, unless otherwise stated. More information in 1.2 Conventions
3:0	PRRSSEL CC1 async channel select	0x0	RW	CC1 async channel select

13.5.60 PRS_CONSUMER_TIMER1_CC2 - CC2 Consumer Register

Offset	Bit Position																																						
0x168	31	30	29	28	27	26	25	24	23	22	21	20	19	18	17	16	15	14	13	12	11	10	9	8	7	6	5	4	3	2	1	0							
Reset																							0x0											0x0					
Access																							RW											RW					
Name																							SPRSSEL										PRRSSEL						

Bit	Name	Reset	Access	Description
31:10	Reserved	To ensure compatibility with future devices, always write Reserved bits to their reset value, unless otherwise stated. More information in 1.2 Conventions		
9:8	SPRSSEL CC2 sync channel select	0x0	RW	CC2 sync channel select
7:4	Reserved	To ensure compatibility with future devices, always write Reserved bits to their reset value, unless otherwise stated. More information in 1.2 Conventions		
3:0	PRRSSEL CC2 async channel select	0x0	RW	CC2 async channel select

13.5.61 PRS_CONSUMER_TIMER1_DTI - DTI Consumer Register

Offset	Bit Position																																				
0x16C	31	30	29	28	27	26	25	24	23	22	21	20	19	18	17	16	15	14	13	12	11	10	9	8	7	6	5	4	3	2	1	0					
Reset																																0x0					
Access																																RW					
Name																																PRRSSEL					

Bit	Name	Reset	Access	Description
31:4	Reserved	To ensure compatibility with future devices, always write Reserved bits to their reset value, unless otherwise stated. More information in 1.2 Conventions		
3:0	PRRSSEL DTI async channel select	0x0	RW	DTI async channel select

13.5.62 PRS_CONSUMER_TIMER1_DTIFS1 - DTI Consumer Register

Offset	Bit Position																															
0x170	31	30	29	28	27	26	25	24	23	22	21	20	19	18	17	16	15	14	13	12	11	10	9	8	7	6	5	4	3	2	1	0
Reset																											PRSEL		0x0			
Access																											RW					
Name																											PRSEL					

Bit	Name	Reset	Access	Description
31:4	Reserved	To ensure compatibility with future devices, always write Reserved bits to their reset value, unless otherwise stated. More information in 1.2 Conventions		
3:0	PRSEL DTI async channel select	0x0	RW	DTI async channel select

13.5.63 PRS_CONSUMER_TIMER1_DTIFS2 - DTI Consumer Register

Offset	Bit Position																															
0x174	31	30	29	28	27	26	25	24	23	22	21	20	19	18	17	16	15	14	13	12	11	10	9	8	7	6	5	4	3	2	1	0
Reset																											PRSEL		0x0			
Access																											RW					
Name																											PRSEL					

Bit	Name	Reset	Access	Description
31:4	Reserved	To ensure compatibility with future devices, always write Reserved bits to their reset value, unless otherwise stated. More information in 1.2 Conventions		
3:0	PRSEL DTI async channel select	0x0	RW	DTI async channel select

13.5.64 PRS_CONSUMER_TIMER2_CC0 - CC0 Consumer Register

Offset	Bit Position																																												
0x178	31	30	29	28	27	26	25	24	23	22	21	20	19	18	17	16	15	14	13	12	11	10	9	8	7	6	5	4	3	2	1	0													
Reset																							0x0						0x0																
Access																							RW						RW																
Name																							SPRSSEL																	PRRSSEL					

Bit	Name	Reset	Access	Description
31:10	Reserved	To ensure compatibility with future devices, always write Reserved bits to their reset value, unless otherwise stated. More information in 1.2 Conventions		
9:8	SPRSSEL CC0 sync channel select	0x0	RW	CC0 sync channel select
7:4	Reserved	To ensure compatibility with future devices, always write Reserved bits to their reset value, unless otherwise stated. More information in 1.2 Conventions		
3:0	PRRSSEL CC0 async channel select	0x0	RW	CC0 async channel select

13.5.65 PRS_CONSUMER_TIMER2_CC1 - CC1 Consumer Register

Offset	Bit Position																																												
0x17C	31	30	29	28	27	26	25	24	23	22	21	20	19	18	17	16	15	14	13	12	11	10	9	8	7	6	5	4	3	2	1	0													
Reset																							0x0						0x0																
Access																							RW						RW																
Name																							SPRSSEL																	PRRSSEL					

Bit	Name	Reset	Access	Description
31:10	Reserved	To ensure compatibility with future devices, always write Reserved bits to their reset value, unless otherwise stated. More information in 1.2 Conventions		
9:8	SPRSSEL CC1 sync channel select	0x0	RW	CC1 sync channel select
7:4	Reserved	To ensure compatibility with future devices, always write Reserved bits to their reset value, unless otherwise stated. More information in 1.2 Conventions		
3:0	PRRSSEL CC1 async channel select	0x0	RW	CC1 async channel select

13.5.66 PRS_CONSUMER_TIMER2_CC2 - CC2 Consumer Register

Offset	Bit Position																																					
0x180	31	30	29	28	27	26	25	24	23	22	21	20	19	18	17	16	15	14	13	12	11	10	9	8	7	6	5	4	3	2	1	0						
Reset																							0x0															
Access																							RW															
Name																							SPRSSEL										PRRSEL					

Bit	Name	Reset	Access	Description
31:10	Reserved	To ensure compatibility with future devices, always write Reserved bits to their reset value, unless otherwise stated. More information in 1.2 Conventions		
9:8	SPRSSEL CC2 sync channel select	0x0	RW	CC2 sync channel select
7:4	Reserved	To ensure compatibility with future devices, always write Reserved bits to their reset value, unless otherwise stated. More information in 1.2 Conventions		
3:0	PRRSEL CC2 async channel select	0x0	RW	CC2 async channel select

13.5.67 PRS_CONSUMER_TIMER2_DTI - DTI Consumer Register

Offset	Bit Position																																				
0x184	31	30	29	28	27	26	25	24	23	22	21	20	19	18	17	16	15	14	13	12	11	10	9	8	7	6	5	4	3	2	1	0					
Reset																																	0x0				
Access																																	RW				
Name																																	PRRSEL				

Bit	Name	Reset	Access	Description
31:4	Reserved	To ensure compatibility with future devices, always write Reserved bits to their reset value, unless otherwise stated. More information in 1.2 Conventions		
3:0	PRRSEL DTI async channel select	0x0	RW	DTI async channel select

13.5.68 PRS_CONSUMER_TIMER2_DTIFS1 - DTI Consumer Register

Offset	Bit Position																															
0x188	31	30	29	28	27	26	25	24	23	22	21	20	19	18	17	16	15	14	13	12	11	10	9	8	7	6	5	4	3	2	1	0
Reset																											PRSEL		0x0			
Access																											RW					
Name																											PRSEL					

Bit	Name	Reset	Access	Description
31:4	Reserved	To ensure compatibility with future devices, always write Reserved bits to their reset value, unless otherwise stated. More information in 1.2 Conventions		
3:0	PRSEL DTI async channel select	0x0	RW	DTI async channel select

13.5.69 PRS_CONSUMER_TIMER2_DTIFS2 - DTI Consumer Register

Offset	Bit Position																															
0x18C	31	30	29	28	27	26	25	24	23	22	21	20	19	18	17	16	15	14	13	12	11	10	9	8	7	6	5	4	3	2	1	0
Reset																											PRSEL		0x0			
Access																											RW					
Name																											PRSEL					

Bit	Name	Reset	Access	Description
31:4	Reserved	To ensure compatibility with future devices, always write Reserved bits to their reset value, unless otherwise stated. More information in 1.2 Conventions		
3:0	PRSEL DTI async channel select	0x0	RW	DTI async channel select

13.5.70 PRS_CONSUMER_TIMER3_CC0 - CC0 Consumer Register

Offset	Bit Position																																										
0x190	31	30	29	28	27	26	25	24	23	22	21	20	19	18	17	16	15	14	13	12	11	10	9	8	7	6	5	4	3	2	1	0											
Reset																							0x0							0x0													
Access																							RW							RW													
Name																							SPRSSEL														PRRSSEL						

Bit	Name	Reset	Access	Description
31:10	Reserved			To ensure compatibility with future devices, always write Reserved bits to their reset value, unless otherwise stated. More information in 1.2 Conventions
9:8	SPRSSEL CC0 sync channel select	0x0	RW	CC0 sync channel select
7:4	Reserved			To ensure compatibility with future devices, always write Reserved bits to their reset value, unless otherwise stated. More information in 1.2 Conventions
3:0	PRRSSEL CC0 async channel select	0x0	RW	CC0 async channel select

13.5.71 PRS_CONSUMER_TIMER3_CC1 - CC1 Consumer Register

Offset	Bit Position																																										
0x194	31	30	29	28	27	26	25	24	23	22	21	20	19	18	17	16	15	14	13	12	11	10	9	8	7	6	5	4	3	2	1	0											
Reset																							0x0							0x0													
Access																							RW							RW													
Name																							SPRSSEL														PRRSSEL						

Bit	Name	Reset	Access	Description
31:10	Reserved			To ensure compatibility with future devices, always write Reserved bits to their reset value, unless otherwise stated. More information in 1.2 Conventions
9:8	SPRSSEL CC1 sync channel select	0x0	RW	CC1 sync channel select
7:4	Reserved			To ensure compatibility with future devices, always write Reserved bits to their reset value, unless otherwise stated. More information in 1.2 Conventions
3:0	PRRSSEL CC1 async channel select	0x0	RW	CC1 async channel select

13.5.72 PRS_CONSUMER_TIMER3_CC2 - CC2 Consumer Register

Offset	Bit Position																																											
0x198	31	30	29	28	27	26	25	24	23	22	21	20	19	18	17	16	15	14	13	12	11	10	9	8	7	6	5	4	3	2	1	0												
Reset																							0x0																0x0					
Access																							RW																RW					
Name																							SPRSSEL															PRRSSEL						

Bit	Name	Reset	Access	Description
31:10	Reserved	To ensure compatibility with future devices, always write Reserved bits to their reset value, unless otherwise stated. More information in 1.2 Conventions		
9:8	SPRSSEL CC2 sync channel select	0x0	RW	CC2 sync channel select
7:4	Reserved	To ensure compatibility with future devices, always write Reserved bits to their reset value, unless otherwise stated. More information in 1.2 Conventions		
3:0	PRRSSEL CC2 async channel select	0x0	RW	CC2 async channel select

13.5.73 PRS_CONSUMER_TIMER3_DTI - DTI Consumer Register

Offset	Bit Position																																										
0x19C	31	30	29	28	27	26	25	24	23	22	21	20	19	18	17	16	15	14	13	12	11	10	9	8	7	6	5	4	3	2	1	0											
Reset																																						0x0					
Access																																						RW					
Name																																						PRRSSEL					

Bit	Name	Reset	Access	Description
31:4	Reserved	To ensure compatibility with future devices, always write Reserved bits to their reset value, unless otherwise stated. More information in 1.2 Conventions		
3:0	PRRSSEL DTI async channel select	0x0	RW	DTI async channel select

13.5.74 PRS_CONSUMER_TIMER3_DTIFS1 - DTI Consumer Register

Offset	Bit Position																															
0x1A0	31	30	29	28	27	26	25	24	23	22	21	20	19	18	17	16	15	14	13	12	11	10	9	8	7	6	5	4	3	2	1	0
Reset																											PRSEL		0x0			
Access																											RW					
Name																											PRSEL					

Bit	Name	Reset	Access	Description
31:4	Reserved	To ensure compatibility with future devices, always write Reserved bits to their reset value, unless otherwise stated. More information in 1.2 Conventions		
3:0	PRSEL	0x0	RW	DTI async channel select DTI async channel select

13.5.75 PRS_CONSUMER_TIMER3_DTIFS2 - DTI Consumer Register

Offset	Bit Position																															
0x1A4	31	30	29	28	27	26	25	24	23	22	21	20	19	18	17	16	15	14	13	12	11	10	9	8	7	6	5	4	3	2	1	0
Reset																											PRSEL		0x0			
Access																											RW					
Name																											PRSEL					

Bit	Name	Reset	Access	Description
31:4	Reserved	To ensure compatibility with future devices, always write Reserved bits to their reset value, unless otherwise stated. More information in 1.2 Conventions		
3:0	PRSEL	0x0	RW	DTI async channel select DTI async channel select

13.5.76 PRS_CONSUMER_TIMER4_CC0 - CC0 Consumer Register

Offset	Bit Position																																										
0x1A8	31	30	29	28	27	26	25	24	23	22	21	20	19	18	17	16	15	14	13	12	11	10	9	8	7	6	5	4	3	2	1	0											
Reset																							0x0							0x0													
Access																							RW							RW													
Name																							SPRSSEL														PRSEL						

Bit	Name	Reset	Access	Description
31:10	Reserved			To ensure compatibility with future devices, always write Reserved bits to their reset value, unless otherwise stated. More information in 1.2 Conventions
9:8	SPRSSEL CC0 sync channel select	0x0	RW	CC0 sync channel select
7:4	Reserved			To ensure compatibility with future devices, always write Reserved bits to their reset value, unless otherwise stated. More information in 1.2 Conventions
3:0	PRSEL CC0 async channel select	0x0	RW	CC0 async channel select

13.5.77 PRS_CONSUMER_TIMER4_CC1 - CC1 Consumer Register

Offset	Bit Position																																										
0x1AC	31	30	29	28	27	26	25	24	23	22	21	20	19	18	17	16	15	14	13	12	11	10	9	8	7	6	5	4	3	2	1	0											
Reset																							0x0							0x0													
Access																							RW							RW													
Name																							SPRSSEL														PRSEL						

Bit	Name	Reset	Access	Description
31:10	Reserved			To ensure compatibility with future devices, always write Reserved bits to their reset value, unless otherwise stated. More information in 1.2 Conventions
9:8	SPRSSEL CC1 sync channel select	0x0	RW	CC1 sync channel select
7:4	Reserved			To ensure compatibility with future devices, always write Reserved bits to their reset value, unless otherwise stated. More information in 1.2 Conventions
3:0	PRSEL CC1 async channel select	0x0	RW	CC1 async channel select

13.5.78 PRS_CONSUMER_TIMER4_CC2 - CC2 Consumer Register

Offset	Bit Position																																						
0x1B0	31	30	29	28	27	26	25	24	23	22	21	20	19	18	17	16	15	14	13	12	11	10	9	8	7	6	5	4	3	2	1	0							
Reset																							0x0											0x0					
Access																							RW											RW					
Name																							SPRSSEL										PRRSSEL						

Bit	Name	Reset	Access	Description
31:10	Reserved	To ensure compatibility with future devices, always write Reserved bits to their reset value, unless otherwise stated. More information in 1.2 Conventions		
9:8	SPRSSEL CC2 sync channel select	0x0	RW	CC2 sync channel select
7:4	Reserved	To ensure compatibility with future devices, always write Reserved bits to their reset value, unless otherwise stated. More information in 1.2 Conventions		
3:0	PRRSSEL CC2 async channel select	0x0	RW	CC2 async channel select

13.5.79 PRS_CONSUMER_TIMER4_DTI - DTI Consumer Register

Offset	Bit Position																																					
0x1B4	31	30	29	28	27	26	25	24	23	22	21	20	19	18	17	16	15	14	13	12	11	10	9	8	7	6	5	4	3	2	1	0						
Reset																																	0x0					
Access																																	RW					
Name																																	PRRSSEL					

Bit	Name	Reset	Access	Description
31:4	Reserved	To ensure compatibility with future devices, always write Reserved bits to their reset value, unless otherwise stated. More information in 1.2 Conventions		
3:0	PRRSSEL DTI async channel select	0x0	RW	DTI async channel select

13.5.80 PRS_CONSUMER_TIMER4_DTIFS1 - DTI Consumer Register

Offset	Bit Position																															
0x1B8	31	30	29	28	27	26	25	24	23	22	21	20	19	18	17	16	15	14	13	12	11	10	9	8	7	6	5	4	3	2	1	0
Reset																											0x0					
Access																											RW					
Name																											PRSEL					

Bit	Name	Reset	Access	Description
31:4	Reserved	To ensure compatibility with future devices, always write Reserved bits to their reset value, unless otherwise stated. More information in 1.2 Conventions		
3:0	PRSEL DTI async channel select	0x0	RW	DTI async channel select

13.5.81 PRS_CONSUMER_TIMER4_DTIFS2 - DTI Consumer Register

Offset	Bit Position																															
0x1BC	31	30	29	28	27	26	25	24	23	22	21	20	19	18	17	16	15	14	13	12	11	10	9	8	7	6	5	4	3	2	1	0
Reset																											0x0					
Access																											RW					
Name																											PRSEL					

Bit	Name	Reset	Access	Description
31:4	Reserved	To ensure compatibility with future devices, always write Reserved bits to their reset value, unless otherwise stated. More information in 1.2 Conventions		
3:0	PRSEL DTI async channel select	0x0	RW	DTI async channel select

13.5.82 PRS_CONSUMER_USART0_CLK - CLK Consumer Register

Offset	Bit Position																															
0x1C0	31	30	29	28	27	26	25	24	23	22	21	20	19	18	17	16	15	14	13	12	11	10	9	8	7	6	5	4	3	2	1	0
Reset																											PRSEL		0x0			
Access																											RW					
Name																											PRSEL					

Bit	Name	Reset	Access	Description
31:4	Reserved	To ensure compatibility with future devices, always write Reserved bits to their reset value, unless otherwise stated. More information in 1.2 Conventions		
3:0	PRSEL CLK async channel select	0x0	RW	CLK async channel select

13.5.83 PRS_CONSUMER_USART0_IR - IR Consumer Register

Offset	Bit Position																															
0x1C4	31	30	29	28	27	26	25	24	23	22	21	20	19	18	17	16	15	14	13	12	11	10	9	8	7	6	5	4	3	2	1	0
Reset																											PRSEL		0x0			
Access																											RW					
Name																											PRSEL					

Bit	Name	Reset	Access	Description
31:4	Reserved	To ensure compatibility with future devices, always write Reserved bits to their reset value, unless otherwise stated. More information in 1.2 Conventions		
3:0	PRSEL IR async channel select	0x0	RW	IR async channel select

13.5.84 PRS_CONSUMER_USART0_RX - RX Consumer Register

Offset	Bit Position																															
0x1C8	31	30	29	28	27	26	25	24	23	22	21	20	19	18	17	16	15	14	13	12	11	10	9	8	7	6	5	4	3	2	1	0
Reset																											0x0					
Access																											RW					
Name																											PRSSEL					

Bit	Name	Reset	Access	Description
31:4	Reserved	To ensure compatibility with future devices, always write Reserved bits to their reset value, unless otherwise stated. More information in 1.2 Conventions		
3:0	PRSSEL RX async channel select	0x0	RW	RX async channel select

13.5.85 PRS_CONSUMER_USART0_TRIGGER - TRIGGER Consumer Register

Offset	Bit Position																															
0x1CC	31	30	29	28	27	26	25	24	23	22	21	20	19	18	17	16	15	14	13	12	11	10	9	8	7	6	5	4	3	2	1	0
Reset																											0x0					
Access																											RW					
Name																											PRSSEL					

Bit	Name	Reset	Access	Description
31:4	Reserved	To ensure compatibility with future devices, always write Reserved bits to their reset value, unless otherwise stated. More information in 1.2 Conventions		
3:0	PRSSEL TRIGGER async channel select	0x0	RW	TRIGGER async channel select

13.5.86 PRS_CONSUMER_VDAC0_ASYNCTRIGCH0 - ASYNCTRIG Consumer Register

Offset	Bit Position																															
0x1DC	31	30	29	28	27	26	25	24	23	22	21	20	19	18	17	16	15	14	13	12	11	10	9	8	7	6	5	4	3	2	1	0
Reset																											PRSEL		0x0			
Access																											RW					
Name																											PRSEL					

Bit	Name	Reset	Access	Description
31:4	Reserved	To ensure compatibility with future devices, always write Reserved bits to their reset value, unless otherwise stated. More information in 1.2 Conventions		
3:0	PRSEL	0x0	RW	ASYNCTRIG async channel select ASYNCTRIG async channel select

13.5.87 PRS_CONSUMER_VDAC0_ASYNCTRIGCH1 - ASYNCTRIG Consumer Register

Offset	Bit Position																															
0x1E0	31	30	29	28	27	26	25	24	23	22	21	20	19	18	17	16	15	14	13	12	11	10	9	8	7	6	5	4	3	2	1	0
Reset																											PRSEL		0x0			
Access																											RW					
Name																											PRSEL					

Bit	Name	Reset	Access	Description
31:4	Reserved	To ensure compatibility with future devices, always write Reserved bits to their reset value, unless otherwise stated. More information in 1.2 Conventions		
3:0	PRSEL	0x0	RW	ASYNCTRIG async channel select ASYNCTRIG async channel select

13.5.88 PRS_CONSUMER_VDAC0_SYNCTRIGCH0 - SYNCTRIG Consumer Register

Offset	Bit Position																															
0x1E4	31	30	29	28	27	26	25	24	23	22	21	20	19	18	17	16	15	14	13	12	11	10	9	8	7	6	5	4	3	2	1	0
Reset																							0x0									
Access																							RW									
Name																							SPRSSEL									

Bit	Name	Reset	Access	Description
31:10	Reserved			To ensure compatibility with future devices, always write Reserved bits to their reset value, unless otherwise stated. More information in 1.2 Conventions
9:8	SPRSSEL	0x0	RW	SYNCTRIG sync channel select SYNCTRIG sync channel select
7:0	Reserved			To ensure compatibility with future devices, always write Reserved bits to their reset value, unless otherwise stated. More information in 1.2 Conventions

13.5.89 PRS_CONSUMER_VDAC0_SYNCTRIGCH1 - SYNCTRIG Consumer Register

Offset	Bit Position																															
0x1E8	31	30	29	28	27	26	25	24	23	22	21	20	19	18	17	16	15	14	13	12	11	10	9	8	7	6	5	4	3	2	1	0
Reset																							0x0									
Access																							RW									
Name																							SPRSSEL									

Bit	Name	Reset	Access	Description
31:10	Reserved			To ensure compatibility with future devices, always write Reserved bits to their reset value, unless otherwise stated. More information in 1.2 Conventions
9:8	SPRSSEL	0x0	RW	SYNCTRIG sync channel select SYNCTRIG sync channel select
7:0	Reserved			To ensure compatibility with future devices, always write Reserved bits to their reset value, unless otherwise stated. More information in 1.2 Conventions

13.5.90 PRS_CONSUMER_VDAC1_ASYNCTRIGCH0 - ASYNCTRIG Consumer Register

Offset	Bit Position																															
0x1EC	31	30	29	28	27	26	25	24	23	22	21	20	19	18	17	16	15	14	13	12	11	10	9	8	7	6	5	4	3	2	1	0
Reset																											PRSEL		0x0			
Access																											RW					
Name																											PRSEL					

Bit	Name	Reset	Access	Description
31:4	Reserved			To ensure compatibility with future devices, always write Reserved bits to their reset value, unless otherwise stated. More information in 1.2 Conventions
3:0	PRSEL	0x0	RW	ASYNCTRIG async channel select ASYNCTRIG async channel select

13.5.91 PRS_CONSUMER_VDAC1_ASYNCTRIGCH1 - ASYNCTRIG Consumer Register

Offset	Bit Position																															
0x1F0	31	30	29	28	27	26	25	24	23	22	21	20	19	18	17	16	15	14	13	12	11	10	9	8	7	6	5	4	3	2	1	0
Reset																											PRSEL		0x0			
Access																											RW					
Name																											PRSEL					

Bit	Name	Reset	Access	Description
31:4	Reserved			To ensure compatibility with future devices, always write Reserved bits to their reset value, unless otherwise stated. More information in 1.2 Conventions
3:0	PRSEL	0x0	RW	ASYNCTRIG async channel select ASYNCTRIG async channel select

13.5.92 PRS_CONSUMER_VDAC1_SYNCTRIGCH0 - SYNCTRIG Consumer Register

Offset	Bit Position																															
0x1F4	31	30	29	28	27	26	25	24	23	22	21	20	19	18	17	16	15	14	13	12	11	10	9	8	7	6	5	4	3	2	1	0
Reset																							0x0									
Access																							RW									
Name																							SPRSSEL									

Bit	Name	Reset	Access	Description
31:10	Reserved			To ensure compatibility with future devices, always write Reserved bits to their reset value, unless otherwise stated. More information in 1.2 Conventions
9:8	SPRSSEL	0x0	RW	SYNCTRIG sync channel select SYNCTRIG sync channel select
7:0	Reserved			To ensure compatibility with future devices, always write Reserved bits to their reset value, unless otherwise stated. More information in 1.2 Conventions

13.5.93 PRS_CONSUMER_VDAC1_SYNCTRIGCH1 - SYNCTRIG Consumer Register

Offset	Bit Position																															
0x1F8	31	30	29	28	27	26	25	24	23	22	21	20	19	18	17	16	15	14	13	12	11	10	9	8	7	6	5	4	3	2	1	0
Reset																							0x0									
Access																							RW									
Name																							SPRSSEL									

Bit	Name	Reset	Access	Description
31:10	Reserved			To ensure compatibility with future devices, always write Reserved bits to their reset value, unless otherwise stated. More information in 1.2 Conventions
9:8	SPRSSEL	0x0	RW	SYNCTRIG sync channel select SYNCTRIG sync channel select
7:0	Reserved			To ensure compatibility with future devices, always write Reserved bits to their reset value, unless otherwise stated. More information in 1.2 Conventions

13.5.94 PRS_CONSUMER_WDOG0_SRC0 - SRC0 Consumer Register

Offset	Bit Position																															
0x1FC	31	30	29	28	27	26	25	24	23	22	21	20	19	18	17	16	15	14	13	12	11	10	9	8	7	6	5	4	3	2	1	0
Reset																											0x0					
Access																											RW					
Name																											PRSEL					

Bit	Name	Reset	Access	Description
31:4	Reserved			To ensure compatibility with future devices, always write Reserved bits to their reset value, unless otherwise stated. More information in 1.2 Conventions
3:0	PRSEL SRC0 async channel select	0x0	RW	SRC0 async channel select

13.5.95 PRS_CONSUMER_WDOG0_SRC1 - SRC1 Consumer Register

Offset	Bit Position																															
0x200	31	30	29	28	27	26	25	24	23	22	21	20	19	18	17	16	15	14	13	12	11	10	9	8	7	6	5	4	3	2	1	0
Reset																											0x0					
Access																											RW					
Name																											PRSEL					

Bit	Name	Reset	Access	Description
31:4	Reserved			To ensure compatibility with future devices, always write Reserved bits to their reset value, unless otherwise stated. More information in 1.2 Conventions
3:0	PRSEL SRC1 async channel select	0x0	RW	SRC1 async channel select

13.5.96 PRS_CONSUMER_WDOG1_SRC0 - SRC0 Consumer Register

Offset	Bit Position																															
0x204	31	30	29	28	27	26	25	24	23	22	21	20	19	18	17	16	15	14	13	12	11	10	9	8	7	6	5	4	3	2	1	0
Reset																											0x0					
Access																											RW					
Name																											PRSEL					

Bit	Name	Reset	Access	Description
31:4	Reserved			To ensure compatibility with future devices, always write Reserved bits to their reset value, unless otherwise stated. More information in 1.2 Conventions
3:0	PRSEL	0x0	RW	SRC0 async channel select SRC0 async channel select

13.5.97 PRS_CONSUMER_WDOG1_SRC1 - SRC1 Consumer Register

Offset	Bit Position																															
0x208	31	30	29	28	27	26	25	24	23	22	21	20	19	18	17	16	15	14	13	12	11	10	9	8	7	6	5	4	3	2	1	0
Reset																											0x0					
Access																											RW					
Name																											PRSEL					

Bit	Name	Reset	Access	Description
31:4	Reserved			To ensure compatibility with future devices, always write Reserved bits to their reset value, unless otherwise stated. More information in 1.2 Conventions
3:0	PRSEL	0x0	RW	SRC1 async channel select SRC1 async channel select

14. GPCRC - General Purpose Cyclic Redundancy Check

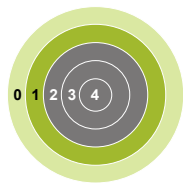

Quick Facts

What?

The GPCRC is an error-detecting module commonly used in digital networks and storage systems to detect accidental changes to data.

Why?

The GPCRC module can detect errors in data, giving a higher system reliability and robustness.

How?

Blocks of data entering GPCRC module can have a short checksum, based on the remainder of a polynomial division of their contents; on retrieval the calculation is repeated, and corrective action can be taken against presumed data corruption if the check values do not match.

14.1 Introduction

The GPCRC module implements a Cyclic Redundancy Check (CRC) function. It supports both 32-bit and 16-bit polynomials. The supported 32-bit polynomial is 0x04C11DB7 (IEEE 802.3), while the 16-bit polynomial can be programmed to any value, depending on the needs of the application. Common 16-bit polynomials are 0x1021 (CCITT-16), 0x3D65 (IEC16-MBus), and 0x8005 (zigbee, 802.15.4, and USB).

14.2 Features

- Programmable 16-bit polynomial, fixed 32-bit polynomial
- Byte-level bit reversal for the CRC input
- Byte-order reorientation for the CRC input
- Word or half-word bit reversal of the CRC result
- Ability to configure and seed an operation in a single register write
- Single-cycle CRC computation for 32-, 16-, or 8-bit blocks
- DMA operation

14.3 Functional Description

An overview of the GPCRC module is shown in [Figure 14.1 GPCRC Overview on page 429](#).

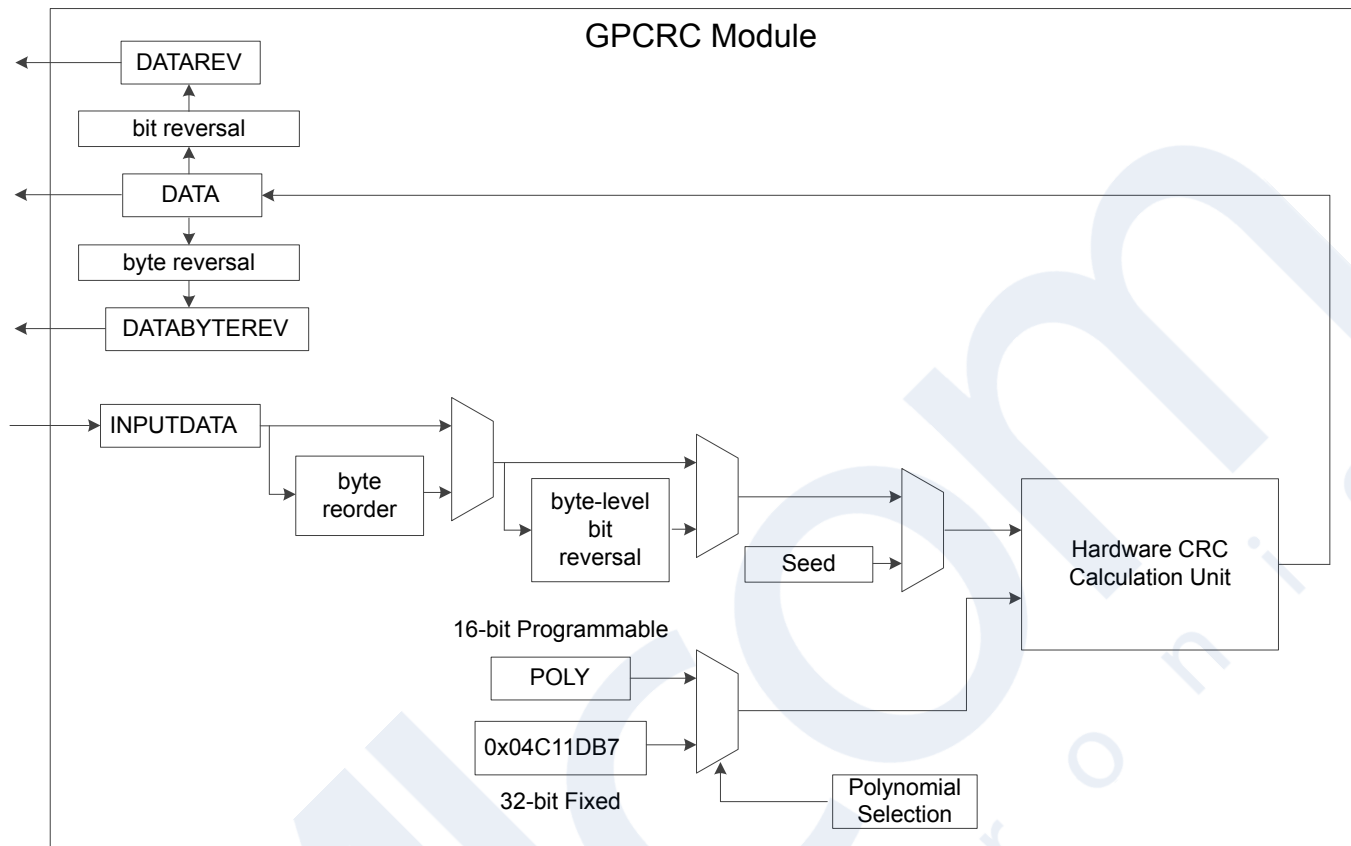

Figure 14.1. GPCRC Overview

14.3.1 Polynomial Specification

POLYSEL in GPCRC_CTRL selects between 32-bit and 16-bit polynomial functions. When a 32-bit polynomial is selected, the fixed IEEE 802.3 polynomial(0x04C11DB7) is used. When a 16-bit polynomial is selected, any valid polynomial can be defined by the user in GPCRC_POLY.

A valid 16-bit CRC polynomial must have an x^{16} term and an x^0 term. Theoretically, a 16-bit polynomial has 17 terms total. The convention used is to omit the x^{16} term. The polynomial should be written in **reversed** (little endian) bit order. The most significant bit corresponds to the lowest order term. Thus, the most significant bit in CRC_POLY represents the x^0 term, and the least significant bit in CRC_POLY represents the x^{15} term. The highest significant bit of CRC_POLY should always set to 1. The polynomial representation for the CRC-16-CCIT polynomial $x^{16} + x^{12} + x^5 + 1$, or 0x8408 in reversed order, is shown in [Figure 14.2 Polynomial Representation on page 430](#).

CRC-16-CCITT Normal: 0x1021 Reversed: 0x8408

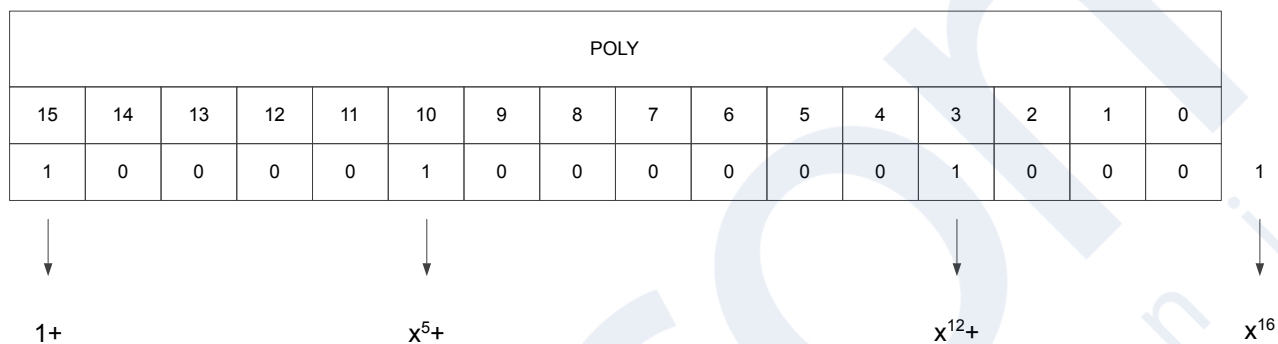

Figure 14.2. Polynomial Representation

14.3.2 Input and Output Specification

The CRC input data can be written to the GPCRC_INPUTDATA, GPCRC_INPUTDATAWORD or GPCRC_INPUTDATABYTE register via the APB bus based on different data size. If BYTEMODE in GPCRC_CTRL is set, only the least significant byte of the data word will be used for the CRC calculation no matter which input register is written. There are also three output registers for different ordering. Reading from GPCRC_DATA will get the result based on the polynomial in reversed order, while reading from GPCRC_DATAREV will get the result based on the polynomial in normal order. The CRC calculation completes in one clock cycle. Reads from the GPCRC_DATA, GPCRC_DATAREV or GPCRC_DATABYTEREV registers and writes to the GPCRC_CMD register are halted while the calculation is in progress.

14.3.3 Initialization

The CRC can be pre-loaded or re-initialized by first writing a 32-bit programmable init value to INIT in GPCRC_INIT and then setting INIT in GPCRC_CMD. It can also be re-initialized automatically when read from DATA, DATAREV or DATABYTEREV provided that AUTOINIT in GPCRC_CTRL is set, the CRC would be re-initialized with the stored init value.

14.3.4 DMA Usage

A DMA channel may be used to transfer data into the CRC engine. All bytes and half-word writes must be word-aligned. The recommended DMA usage model is to use the DMA to transfer all available words of data and use software writes to capture any remaining bytes.

14.3.5 Byte-Level Bit Reversal and Byte Reordering

The byte-level bit reversal and byte reordering operations occur before the data is used in the CRC calculation. Byte reordering can occur on words or half words. The hardware ignores the BYTEREVERSE field with any byte writes or operations with byte mode enabled (BYTEMODE = 1), but the bit reversal settings (BITREVERSE) are still applied to the byte. 32-bit little endian MSB-first data can be treated like 32-bit little endian LSB-first data, as shown in [Figure 14.3 Data Ordering Example - 32-bit MSB -first to LSB-first on page 431](#). In this example, 32-bit data is written to GPCRC_INPUTDATA, BYTEREVERSE is set for byte ordering, and BITREVERSE is set for byte-level bit reversal.

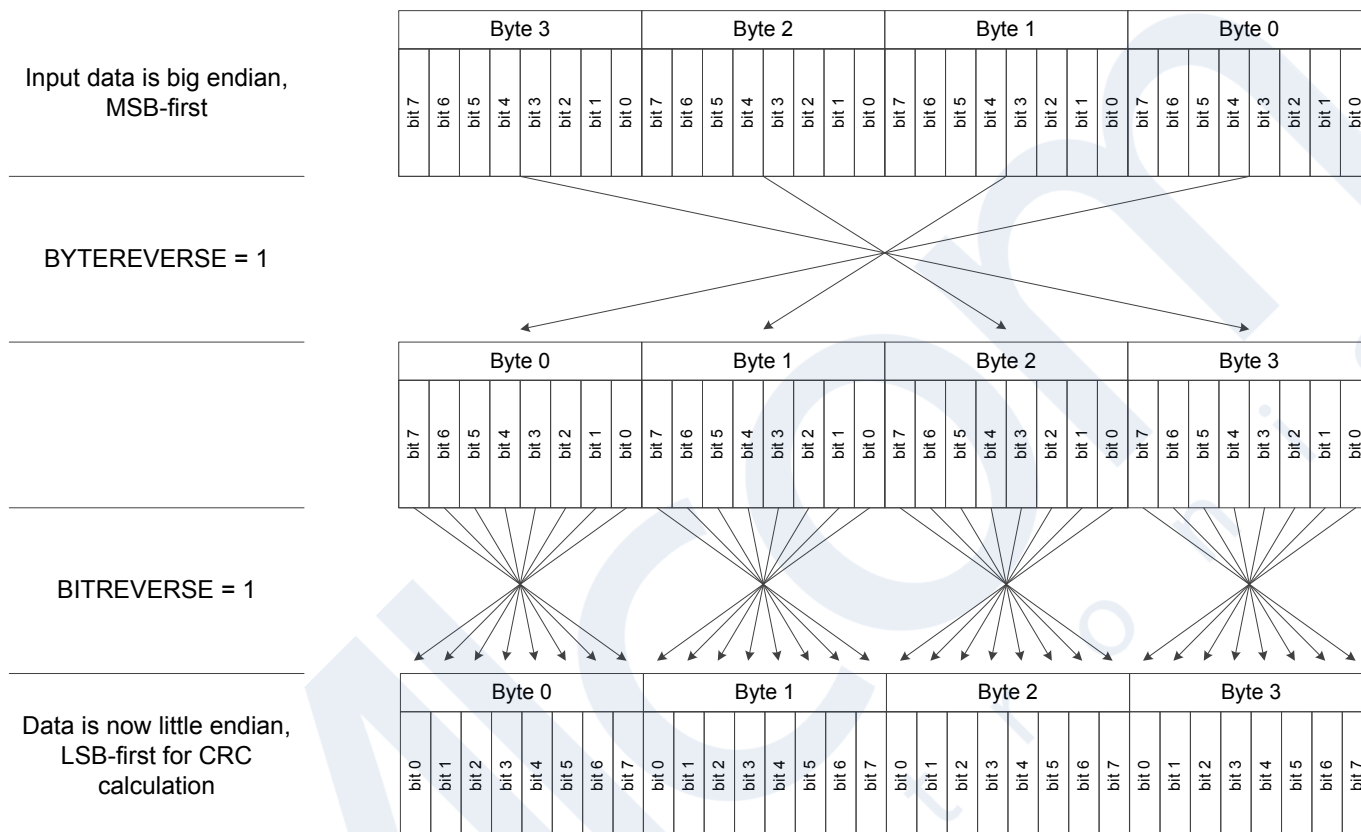

Figure 14.3. Data Ordering Example - 32-bit MSB -first to LSB-first

When handling 16-bit data, the byte reordering function only swap the two lowest bytes and clear the two highest bytes, as shown in [Figure 14.4 Data Ordering Example - 16-bit MSB -first to LSB-first on page 432](#). In this example, 16-bit data is written to GPCRC_INPUTDATAWORD, BYTEREVERSE is set for byte ordering, and BITREVERSE is set for byte-level bit reversal.

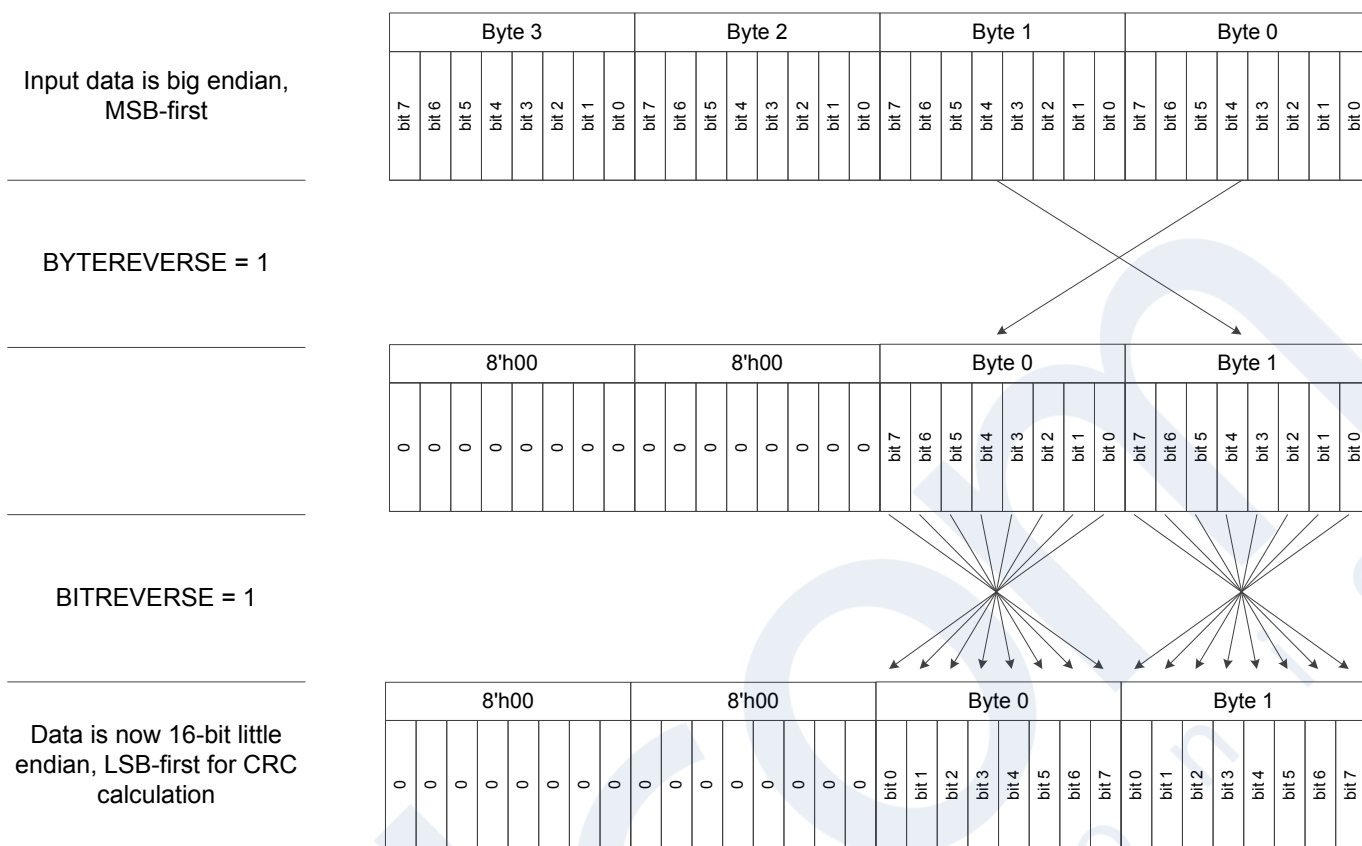

Figure 14.4. Data Ordering Example - 16-bit MSB -first to LSB-first

Assuming a word input byte order of B3 B2 B1 B0, the values used in the CRC calculation for the various settings of the byte-level bit reversal and byte reordering are shown in Table 14.1 Byte-Level Bit Reversal and Byte Reordering Results (B3 B2 B1 B0 Input Order) on page 432.

Table 14.1. Byte-Level Bit Reversal and Byte Reordering Results (B3 B2 B1 B0 Input Order)

Input Width(bits)	BYTEREVERSE Setting	BITREVERSE Setting	Input to CRC Calculation
32	0	0	B3 B2 B1 B0
32	1	1	'B0 'B1 'B2 'B3
32	1	0	B0 B1 B2 B3
32	0	1	'B3 'B2 'B1 'B0
16	0	0	XX XX B1 B0
16	1	1	XX XX 'B0 'B1
16	1	0	XX XX B0 B1
16	0	1	XX XX 'B1 'B0
8	-	0	XX XX XX XX B0
8	-	1	XX XX XX XX 'B0

Input Width(bits)	BYTEREVERSE Setting	BITREVERSE Setting	Input to CRC Calculation
<p>Notes:</p> <ol style="list-style-type: none">1. X indicates a "don't care".2. Bn is the byte field within the word.3. 'Bn is the bit-reversed byte field within the word.			



14.4 GPCRC Register Map

The offset register address is relative to the registers base address.

Offset	Name	Type	Description
0x000	GPCRC_IPVERSION	R	IP Version ID
0x004	GPCRC_EN	RW	CRC Enable
0x008	GPCRC_CTRL	RW	Control Register
0x00C	GPCRC_CMD	W	Command Register
0x010	GPCRC_INIT	RWH	CRC Init Value
0x014	GPCRC_POLY	RW	CRC Polynomial Value
0x018	GPCRC_INPUTDATA	W	Input 32-Bit Data Register
0x01C	GPCRC_INPUTDATAHW ORD	W	Input 16-Bit Data Register
0x020	GPCRC_INPUTDATA BYTE	W	Input 8-Bit Data Register
0x024	GPCRC_DATA	RH(r)	CRC Data Register
0x028	GPCRC_DATAREV	RH(r)	CRC Data Reverse Register
0x02C	GPCRC_DATA BYTEREV	RH(r)	CRC Data Byte Reverse Register
0x1000	GPCRC_IPVERSION_SET	R	IP Version ID
0x1004	GPCRC_EN_SET	RW	CRC Enable
0x1008	GPCRC_CTRL_SET	RW	Control Register
0x100C	GPCRC_CMD_SET	W	Command Register
0x1010	GPCRC_INIT_SET	RWH	CRC Init Value
0x1014	GPCRC_POLY_SET	RW	CRC Polynomial Value
0x1018	GPCRC_INPUTDATA_SET	W	Input 32-Bit Data Register
0x101C	GPCRC_INPUTDATAHW WORD_SET	W	Input 16-Bit Data Register
0x1020	GPCRC_INPUTDATA BYTE_SET	W	Input 8-Bit Data Register
0x1024	GPCRC_DATA_SET	RH(r)	CRC Data Register
0x1028	GPCRC_DATAREV_SET	RH(r)	CRC Data Reverse Register
0x102C	GPCRC_DATA BYTEREV_SET	RH(r)	CRC Data Byte Reverse Register
0x2000	GPCRC_IPVERSION_CLR	R	IP Version ID
0x2004	GPCRC_EN_CLR	RW	CRC Enable
0x2008	GPCRC_CTRL_CLR	RW	Control Register
0x200C	GPCRC_CMD_CLR	W	Command Register
0x2010	GPCRC_INIT_CLR	RWH	CRC Init Value
0x2014	GPCRC_POLY_CLR	RW	CRC Polynomial Value
0x2018	GPCRC_INPUTDATA_CLR	W	Input 32-Bit Data Register
0x201C	GPCRC_INPUTDATAHW WORD_CLR	W	Input 16-Bit Data Register
0x2020	GPCRC_INPUTDATA BYTE_CLR	W	Input 8-Bit Data Register

Offset	Name	Type	Description
0x2024	GPCRC_DATA_CLR	RH(r)	CRC Data Register
0x2028	GPCRC_DATAREV_CLR	RH(r)	CRC Data Reverse Register
0x202C	GPCRC_DATABYTEREV_CLR	RH(r)	CRC Data Byte Reverse Register
0x3000	GPCRC_IPVERSION_TGL	R	IP Version ID
0x3004	GPCRC_EN_TGL	RW	CRC Enable
0x3008	GPCRC_CTRL_TGL	RW	Control Register
0x300C	GPCRC_CMD_TGL	W	Command Register
0x3010	GPCRC_INIT_TGL	RWH	CRC Init Value
0x3014	GPCRC_POLY_TGL	RW	CRC Polynomial Value
0x3018	GPCRC_INPUTDATA_TGL	W	Input 32-Bit Data Register
0x301C	GPCRC_INPUTDATAH-WORD_TGL	W	Input 16-Bit Data Register
0x3020	GPCRC_INPUTDATA-BYTE_TGL	W	Input 8-Bit Data Register
0x3024	GPCRC_DATA_TGL	RH(r)	CRC Data Register
0x3028	GPCRC_DATAREV_TGL	RH(r)	CRC Data Reverse Register
0x302C	GPCRC_DATABYTEREV_TGL	RH(r)	CRC Data Byte Reverse Register

14.5 GPCRC Register Description

14.5.1 GPCRC_IPVERSION - IP Version ID

Offset	Bit Position																															
0x000	31	30	29	28	27	26	25	24	23	22	21	20	19	18	17	16	15	14	13	12	11	10	9	8	7	6	5	4	3	2	1	0
Reset																0x0																
Access																R																
Name																IPVERSION																

Bit	Name	Reset	Access	Description
31:0	IPVERSION	0x0	R	IP Version ID
<p>The read only IPVERSION field gives the version for this module. There may be minor software changes required for modules with different values of IPVERSION.</p>				

14.5.2 GPCRC_EN - CRC Enable

Offset	Bit Position																															
0x004	31	30	29	28	27	26	25	24	23	22	21	20	19	18	17	16	15	14	13	12	11	10	9	8	7	6	5	4	3	2	1	0
Reset																																0x0
Access																																RW
Name																																EN

Bit	Name	Reset	Access	Description
31:1	<i>Reserved</i>	<i>To ensure compatibility with future devices, always write Reserved bits to their reset value, unless otherwise stated. More information in 1.2 Conventions</i>		
0	EN	0x0	RW	CRC Enable The ENABLE bit enables the module. Software should write to CONFIG type registers before setting the ENABLE bit. Software should write to SYNC type registers only after setting the ENABLE bit.
	Value	Mode	Description	
	0	DISABLE	Disable CRC function. Reordering functions are still available. Only BITREVERSE and BYTEREVERSE bits are configurable in this mode.	
	1	ENABLE	Writes to INPUTDATA registers will result in CRC operations.	

14.5.3 GPCRC_CTRL - Control Register

Offset	Bit Position																																									
0x008	31	30	29	28	27	26	25	24	23	22	21	20	19	18	17	16	15	14	13	12	11	10	9	8	7	6	5	4	3	2	1	0										
Reset														0x0			0x0	0x0	0x0					0x0																		
Access														RW			RW	RW	RW																							
Name														AUTOINIT			BYTEREVERSE	BITREVERSE	BYTEMODE																							

Bit	Name	Reset	Access	Description
31:14	Reserved			To ensure compatibility with future devices, always write Reserved bits to their reset value, unless otherwise stated. More information in 1.2 Conventions
13	AUTOINIT	0x0	RW	Auto Init Enable Enables auto init by re-seeding the CRC result based on the value in INIT after reading of DATA, DATAREV or DATABYTEREV.
12:11	Reserved			To ensure compatibility with future devices, always write Reserved bits to their reset value, unless otherwise stated. More information in 1.2 Conventions
10	BYTEREVERSE	0x0	RW	Byte Reverse Mode Allows byte level reverse of bytes B3, B2, B1, B0 within the 32-bit data word
	Value	Mode		Description
	0	NORMAL		No reverse: B3, B2, B1, B0
	1	REVERSED		Reverse byte order. For 32-bit: B0, B1, B2, B3; For 16-bit: 0, 0, B0, B1
9	BITREVERSE	0x0	RW	Byte-level Bit Reverse Enable Reverses bits within each byte of the 32-bit data word
	Value	Mode		Description
	0	NORMAL		No reverse
	1	REVERSED		Reverse bit order in each byte
8	BYTEMODE	0x0	RW	Byte Mode Enable Treats all writes as bytes. Only the least significant byte of the data-word will be used for CRC calculation for all writes
7:5	Reserved			To ensure compatibility with future devices, always write Reserved bits to their reset value, unless otherwise stated. More information in 1.2 Conventions
4	POLYSEL	0x0	RW	Polynomial Select Selects 16-bit CRC programmable polynomial or 32-bit CRC fixed polynomial
	Value	Mode		Description
	0	CRC32		CRC-32 (0x04C11DB7) polynomial selected
	1	CRC16		16-bit CRC programmable polynomial selected

Bit	Name	Reset	Access	Description
3:0	Reserved	To ensure compatibility with future devices, always write Reserved bits to their reset value, unless otherwise stated. More information in 1.2 Conventions		

14.5.4 GPCRC_CMD - Command Register

Offset	Bit Position																															
0x00C	31	30	29	28	27	26	25	24	23	22	21	20	19	18	17	16	15	14	13	12	11	10	9	8	7	6	5	4	3	2	1	0
Reset																																0x0
Access																																W
Name																																INIT

Bit	Name	Reset	Access	Description
31:1	Reserved	To ensure compatibility with future devices, always write Reserved bits to their reset value, unless otherwise stated. More information in 1.2 Conventions		
0	INIT	0x0	W	Initialization Enable Writing 1 to this bit initialize the CRC by writing the INIT value in CRC_INIT to CRC_DATA.

14.5.5 GPCRC_INIT - CRC Init Value

Offset	Bit Position																															
0x010	31	30	29	28	27	26	25	24	23	22	21	20	19	18	17	16	15	14	13	12	11	10	9	8	7	6	5	4	3	2	1	0
Reset																																0x0
Access																																RW
Name																																INIT

Bit	Name	Reset	Access	Description
31:0	INIT	0x0	RW	CRC Initialization Value This value is loaded into CRC_DATA upon issuing the INIT command in CRC_CMD

14.5.6 GPCRC_POLY - CRC Polynomial Value

Offset	Bit Position																															
0x014	31	30	29	28	27	26	25	24	23	22	21	20	19	18	17	16	15	14	13	12	11	10	9	8	7	6	5	4	3	2	1	0
Reset																	0x0															
Access																	RW															
Name																	POLY															

Bit	Name	Reset	Access	Description
31:16	Reserved	To ensure compatibility with future devices, always write Reserved bits to their reset value, unless otherwise stated. More information in 1.2 Conventions		
15:0	POLY	0x0	RW	CRC Polynomial Value This value defines 16-bit POLY, which is used as the polynomial during the 16-bit CRC calculation. The polynomial is defined in reversed representation, meaning that the lowest degree term is in the highest bit position of POLY. Additionally, the highest degree term in the polynomial is implicit. Further examples of the CRC configuration can be found in the documentation.

14.5.7 GPCRC_INPUTDATA - Input 32-Bit Data Register

Offset	Bit Position																															
0x018	31	30	29	28	27	26	25	24	23	22	21	20	19	18	17	16	15	14	13	12	11	10	9	8	7	6	5	4	3	2	1	0
Reset																	0x0															
Access																	W															
Name																	INPUTDATA															

Bit	Name	Reset	Access	Description
31:0	INPUTDATA	0x0	W	Input Data for 32-bit CRC Input 32-bit Data can be written to this register. Each time this register is written, the CRC value is updated.

14.5.8 GPCRC_INPUTDATAWORD - Input 16-Bit Data Register

Offset	Bit Position																															
0x01C	31	30	29	28	27	26	25	24	23	22	21	20	19	18	17	16	15	14	13	12	11	10	9	8	7	6	5	4	3	2	1	0
Reset																	0x0															
Access																	W															
Name																	INPUTDATAWORD															

Bit	Name	Reset	Access	Description
31:16	Reserved	To ensure compatibility with future devices, always write Reserved bits to their reset value, unless otherwise stated. More information in 1.2 Conventions		
15:0	INPUTDATAWORD	0x0	W	Input Data for 16-bit CRC Input 16-bit Data can be written to this register. Each time this register is written, the CRC value is updated.

14.5.9 GPCRC_INPUTDATABYTE - Input 8-Bit Data Register

Offset	Bit Position																															
0x020	31	30	29	28	27	26	25	24	23	22	21	20	19	18	17	16	15	14	13	12	11	10	9	8	7	6	5	4	3	2	1	0
Reset																	0x0															
Access																	W															
Name																	INPUTDATABYTE															

Bit	Name	Reset	Access	Description
31:8	Reserved	To ensure compatibility with future devices, always write Reserved bits to their reset value, unless otherwise stated. More information in 1.2 Conventions		
7:0	INPUTDATABYTE	0x0	W	Input Data for 8-bit CRC Input 8-bit Data can be written to this register. Each time this register is written, the CRC value is updated.

14.5.10 GPCRC_DATA - CRC Data Register

Offset	Bit Position																															
0x024	31	30	29	28	27	26	25	24	23	22	21	20	19	18	17	16	15	14	13	12	11	10	9	8	7	6	5	4	3	2	1	0
Reset																0x0																
Access																R(r)																
Name																DATA																

Bit	Name	Reset	Access	Description
31:0	DATA	0x0	R(r)	CRC Data Register
CRC Data Register, read only. The CRC data register may still be indirectly written from software, by writing the INIT register and then issue an INITIALIZE command.				

14.5.11 GPCRC_DATAREV - CRC Data Reverse Register

Offset	Bit Position																															
0x028	31	30	29	28	27	26	25	24	23	22	21	20	19	18	17	16	15	14	13	12	11	10	9	8	7	6	5	4	3	2	1	0
Reset																0x0																
Access																R(r)																
Name																DATAREV																

Bit	Name	Reset	Access	Description
31:0	DATAREV	0x0	R(r)	Data Reverse Value
Bit reversed version of CRC Data register. When a 32-bit CRC polynomial is selected, the reversal occurs on the entire 32-bit word. When a 16-bit CRC polynomial is selected, the bits [15:0] are reversed.				

14.5.12 GPCRC_DATABYTEREV - CRC Data Byte Reverse Register

Offset	Bit Position																															
0x02C	31	30	29	28	27	26	25	24	23	22	21	20	19	18	17	16	15	14	13	12	11	10	9	8	7	6	5	4	3	2	1	0
Reset																																0x0
Access																																R(r)
Name																																DATABYTEREV

Bit	Name	Reset	Access	Description
31:0	DATABYTEREV	0x0	R(r)	Data Byte Reverse Value Byte reversed version of CRC Data register. When a 32-bit CRC polynomial is selected, the bytes are swizzled to {B0, B1, B2, B3}. When a 16-bit CRC polynomial is selected, the bytes are swizzled to {0, 0, B0, B1}.

15. SYSRTC - System RTC

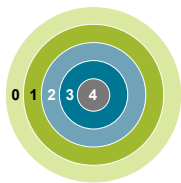

Quick Facts

What?

The System Real-Time Counter (SYSRTC) is a 32-bit Real Time Clock ensuring timekeeping in low energy modes.

Why?

Timekeeping over long time periods while using as little power as possible is required in many low power applications.

How?

The SYSRTC operates a central counter off a low-frequency oscillator source. It has configurable compare and capture channels which can be used to trigger wake-up, generate PRS signalling, or capture system events. The SYSRTC allows the system to stay in low energy modes for long periods of time and maintain reliable timekeeping.

15.1 Introduction

The SYSRTC (System Real Time Counter), is a 32-bit counter kept running down to energy mode EM3. It can be used as a sleep timer / wakeup source as well as a timekeeping counter during low energy modes. Multiple groups of capture / compare registers are available to different cores in the system, allowing the peripheral and time base to be shared across cores and save energy. Only group 0 registers are directly accessible to the main processor core, but compare / capture signals and interrupts from group 1 are also available to the main processor.

Capture compare channels can be used to trigger interrupts, generate PRS signals, capture PRS events, and to wake the device up from EM1, EM2, or EM3.

Note: Critical portions of the EFR32/EFM32 software stack related to system timing and power management make use of SYSRTC in such a way that it is effectively unavailable to user software. Please refer to relevant software documentation for additional information.

15.2 Features

- 32-bit counter
- Debug mode
- 32.768 kHz LFXO or LFRCO / 1 kHz ULFRCO
- Low energy wake-up source
- Separate groups of capture / compare registers and signals
 - MCU core and Radio core each control one group
 - 2 compare channels per group
 - 1 capture channel per group
 - Separate interrupt vectors for MCU and Radio events
 - Capture / compare available in PRS

15.3 Functional Description

15.3.1 Interrupts and Wake Events

Each group has a dedicated, independent interrupt line, and has the ability to wake the system. The Group 0 interrupt line (SYSRTC_APP) is used and fully controlled by user code running on the main processor. The Group 1 interrupt line (SYSRTC_SEQ) is also available to the main processor, but Group 1 registers and configuration are not directly available to the user application.

15.3.2 Counter

A single counter value (CNT) is used across all groups. The SYSRTC module is enabled by setting its EN bit field. The counter value is asserted to 0x00000000 on reset. The counter can be started/stopped by writing to the START/STOP bit fields in the CMD register. The RUNNING field in the STATUS register indicates that the counter is running when it is set.

Once started, the counter increments by 1 on each cycle (typically 32.768 kHz). The counter value can be programmed directly by writing to the CNT register. Once the programmed value is applied and the counter is running, the counter will increment on every clock starting from the newly programmed value.

When the counter reaches its maximum value of 0xFFFFFFFF, an overflow event is generated, followed by a counter wrap-around to its reset value (from which counting continues) and the OVF interrupt flag (OVFIF) on the next cycle. The overflow event is common for all the groups, i.e. OVFIF flags in all groups get set.

The normal operation of SYSRTC is to configure it, enable it, start it, and then leave it running. This should be done by a single core so that other cores only access the registers for their designated group as needed. If SYSRTC needs to be disabled, it is recommended to stop it first using the STOP command.

15.3.3 Compare Events

A compare event for channel "x" of group "n" is generated whenever the counter is RUNNING, the CMPxEN bit is set / enabled in the GRPn_CTRL register, and the CNT value is equal to the GRPn_CMPxVALUE register setting. This event is followed by GRPn_IF.CMPxIF being set on the next counter clock cycle.

Compare events can be routed as PRS producers on the GRPnOUTx signals. There are several options for the match action, selected by CMPxCMOA in GRPn_CTRL. Note that when using the PULSE option, the PRS output should already be cleared for the pulse to get set and the PULSE option should remain configured until the pulse is cleared (otherwise if the PULSE option is reprogrammed to the SET option, the "pulse" remains set). A possible use case when using the CMPxIF option is to signal early events prior to the following wake-up. After wakeup, the compare flag should be processed and cleared. To avoid a race condition on the PRS output, the compare flag should be cleared away from the next possible compare event.

Note that when setting the compare value to the current counter value, a compare event may not get generated until the counter overflows and reaches the current value again. To generate a compare event quickly, it is recommended to program the compare value to the current counter value + 1. Compare events are group-specific.

15.3.4 Capture Events

SYSRTC groups support counter value capture triggered by PRS consumer signals. For group "n" the SYSRTC0 "INn" PRS consumer is used to trigger captures. Capture can be triggered on RISING, FALLING, or BOTH edges, according to the setting programmed in CAP0EDGE of the GRPn_CTRL register. A capture event for group "n" is generated whenever the counter is RUNNING, the CAP0EN bit is set / enabled in the GRPn_CTRL register, and the desired event occurs on the PRS output.

A capture event is followed by GRPn_IF_CAP0IF being set after up to 3 counter clock cycles. At the same time the flag is set, the GRPn_CAP0VALUE register captures the current counter value. Note that PRS input edges should not occur more frequently than once every three counter cycles. If the counter is being started/stopped or GRPn_CTRL.CAP0EN / GRPn_CTRL.CAP0EDGE is changed close to the PRS input edge, a race condition may occur. Capture events are group-specific.

15.3.5 SYSRTC Behavior on SWRST/Disablement/STOP

On SWRST / Disablement, the counter is reset to 0x00000000, PRS outputs are cleared, compare/capture events are disabled, compare/capture flags are reset, and the CAP0VALUE register is reset.

When the counter is stopped using the STOP command in the CMD register, all other settings remain unchanged, except that the RUNNING status will return to 0, which blocks any compare/capture events until the counter is started again.

15.3.6 Debug Functionality

By default, the counter value is frozen when the main processor is halted during debugging. The RUNNING status bit is not affected by debug halt, and will continue to indicate that the counter is active. If DEBUGRUN in the CFG register is set, the counter will not halt when the main processor is halted, and SYSRTC will continue to count clocks.

Note that the main processor runs on a much higher frequency than the counter and that the halt condition needs to last long enough (more than 3 counter cycles) for the counter to reach the frozen state.

15.4 SYSRTC Register Map

The offset register address is relative to the registers base address.

Offset	Name	Type	Description
0x000	SYSRTC_IPVERSION	R	IP VERSION
0x004	SYSRTC_EN	RW ENABLE	Module Enable Register
0x008	SYSRTC_SWRST	RW SWRST	Software Reset Register
0x00C	SYSRTC_CFG	RW CONFIG	Configuration Register
0x010	SYSRTC_CMD	W LFSYNC	Command Register
0x014	SYSRTC_STATUS	RH	Status Register
0x018	SYSRTC_CNT	RWH LFSYNC	Counter Value Register
0x01C	SYSRTC_SYNCBUSY	RH	Synchronization Busy Register
0x020	SYSRTC_LOCK	W	Configuration Lock Register
0x040	SYSRTC_GRP0_IF	RWH INTFLAG	Group Interrupt Flags
0x044	SYSRTC_GRP0_IEN	RW	Group Interrupt Enables
0x048	SYSRTC_GRP0_CTRL	RW	Group Control Register
0x04C	SYSRTC_GRP0_CMP0VALUE	RW	Compare 0 Value Register
0x050	SYSRTC_GRP0_CMP1VALUE	RW	Compare 1 Value Register
0x054	SYSRTC_GRP0_CAP0VALUE	RH	Capture 0 Value Register
0x058	SYSRTC_GRP0_SYNCBUSY	RH	Synchronization Busy Register
0x1000	SYSRTC_IPVERSION_SET	R	IP VERSION
0x1004	SYSRTC_EN_SET	RW ENABLE	Module Enable Register
0x1008	SYSRTC_SWRST_SET	RW SWRST	Software Reset Register
0x100C	SYSRTC_CFG_SET	RW CONFIG	Configuration Register
0x1010	SYSRTC_CMD_SET	W LFSYNC	Command Register
0x1014	SYSRTC_STATUS_SET	RH	Status Register
0x1018	SYSRTC_CNT_SET	RWH LFSYNC	Counter Value Register
0x101C	SYSRTC_SYNCBUSY_SET	RH	Synchronization Busy Register
0x1020	SYSRTC_LOCK_SET	W	Configuration Lock Register
0x1040	SYSRTC_GRP0_IF_SET	RWH INTFLAG	Group Interrupt Flags
0x1044	SYSRTC_GRP0_IEN_SET	RW	Group Interrupt Enables
0x1048	SYSRTC_GRP0_CTRL_SET	RW	Group Control Register
0x104C	SYSRTC_GRP0_CMP0VAL- UE_SET	RW	Compare 0 Value Register
0x1050	SYSRTC_GRP0_CMP1VAL- UE_SET	RW	Compare 1 Value Register
0x1054	SYSRTC_GRP0_CAP0VAL- UE_SET	RH	Capture 0 Value Register
0x1058	SYSRTC_GRP0_SYN- CBUSY_SET	RH	Synchronization Busy Register
0x2000	SYSRTC_IPVERSION_CLR	R	IP VERSION

Offset	Name	Type	Description
0x2004	SYSRTC_EN_CLR	RW ENABLE	Module Enable Register
0x2008	SYSRTC_SWRST_CLR	RW SWRST	Software Reset Register
0x200C	SYSRTC_CFG_CLR	RW CONFIG	Configuration Register
0x2010	SYSRTC_CMD_CLR	W LFSYNC	Command Register
0x2014	SYSRTC_STATUS_CLR	RH	Status Register
0x2018	SYSRTC_CNT_CLR	RWH LFSYNC	Counter Value Register
0x201C	SYSRTC_SYNCBUSY_CLR	RH	Synchronization Busy Register
0x2020	SYSRTC_LOCK_CLR	W	Configuration Lock Register
0x2040	SYSRTC_GRP0_IF_CLR	RWH INTFLAG	Group Interrupt Flags
0x2044	SYSRTC_GRP0_IEN_CLR	RW	Group Interrupt Enables
0x2048	SYSRTC_GRP0_CTRL_CLR	RW	Group Control Register
0x204C	SYSRTC_GRP0_CMP0VAL- UE_CLR	RW	Compare 0 Value Register
0x2050	SYSRTC_GRP0_CMP1VAL- UE_CLR	RW	Compare 1 Value Register
0x2054	SYSRTC_GRP0_CAP0VAL- UE_CLR	RH	Capture 0 Value Register
0x2058	SYSRTC_GRP0_SYN- CBUSY_CLR	RH	Synchronization Busy Register
0x3000	SYSRTC_IPVERSION_TGL	R	IP VERSION
0x3004	SYSRTC_EN_TGL	RW ENABLE	Module Enable Register
0x3008	SYSRTC_SWRST_TGL	RW SWRST	Software Reset Register
0x300C	SYSRTC_CFG_TGL	RW CONFIG	Configuration Register
0x3010	SYSRTC_CMD_TGL	W LFSYNC	Command Register
0x3014	SYSRTC_STATUS_TGL	RH	Status Register
0x3018	SYSRTC_CNT_TGL	RWH LFSYNC	Counter Value Register
0x301C	SYSRTC_SYNCBUSY_TGL	RH	Synchronization Busy Register
0x3020	SYSRTC_LOCK_TGL	W	Configuration Lock Register
0x3040	SYSRTC_GRP0_IF_TGL	RWH INTFLAG	Group Interrupt Flags
0x3044	SYSRTC_GRP0_IEN_TGL	RW	Group Interrupt Enables
0x3048	SYSRTC_GRP0_CTRL_TGL	RW	Group Control Register
0x304C	SYSRTC_GRP0_CMP0VAL- UE_TGL	RW	Compare 0 Value Register
0x3050	SYSRTC_GRP0_CMP1VAL- UE_TGL	RW	Compare 1 Value Register
0x3054	SYSRTC_GRP0_CAP0VAL- UE_TGL	RH	Capture 0 Value Register
0x3058	SYSRTC_GRP0_SYN- CBUSY_TGL	RH	Synchronization Busy Register

15.5 SYSRTC Register Description

15.5.1 SYSRTC_IPVERSION - IP VERSION

Offset	Bit Position																															
0x000	31	30	29	28	27	26	25	24	23	22	21	20	19	18	17	16	15	14	13	12	11	10	9	8	7	6	5	4	3	2	1	0
Reset	0x1																															
Access	R																															
Name	IPVERSION																															

Bit	Name	Reset	Access	Description
31:0	IPVERSION	0x1	R	IP VERSION Gives access to the IP VERSION of SYSRTC

15.5.2 SYSRTC_EN - Module Enable Register

Offset	Bit Position																															
0x004	31	30	29	28	27	26	25	24	23	22	21	20	19	18	17	16	15	14	13	12	11	10	9	8	7	6	5	4	3	2	1	0
Reset																															0x0	0x0
Access																															R	RW
Name																															DISABLING	EN

Bit	Name	Reset	Access	Description
31:2	Reserved	<i>To ensure compatibility with future devices, always write Reserved bits to their reset value, unless otherwise stated. More information in 1.2 Conventions</i>		
1	DISABLING	0x0	R	Disablement busy status Set when EN cleared and cleared when the peripheal core reset is finished
0	EN	0x0	RW	SYSRTC Enable Enable the SYSRTC by requesting Clk from CMU

15.5.3 SYSRTC_SWRST - Software Reset Register

Offset	Bit Position																															
0x008	31	30	29	28	27	26	25	24	23	22	21	20	19	18	17	16	15	14	13	12	11	10	9	8	7	6	5	4	3	2	1	0
Reset																											0x0	0x0				
Access																											R	W				
Name																											RESETTING	SWRST				

Bit	Name	Reset	Access	Description
31:2	Reserved	To ensure compatibility with future devices, always write Reserved bits to their reset value, unless otherwise stated. More information in 1.2 Conventions		
1	RESETTING	0x0	R	Software reset busy status When SWRST command is issued, resetting logic sets this status immediately and it is later cleared when the reset process is finished
0	SWRST	0x0	W	Software reset command A software reset command field resets the module back to the initial condition, similar to the power-on reset condition

15.5.4 SYSRTC_CFG - Configuration Register

Offset	Bit Position																															
0x00C	31	30	29	28	27	26	25	24	23	22	21	20	19	18	17	16	15	14	13	12	11	10	9	8	7	6	5	4	3	2	1	0
Reset																												0x0				
Access																												RW				
Name																												DEBUGRUN				

Bit	Name	Reset	Access	Description
31:1	Reserved	To ensure compatibility with future devices, always write Reserved bits to their reset value, unless otherwise stated. More information in 1.2 Conventions		
0	DEBUGRUN	0x0	RW	Debug Mode Run Enable Set this bit to keep the SYSRTC running during a debug halt.
	Value	Mode	Description	
	0	DISABLE	SYSRTC is frozen in debug mode	
	1	ENABLE	SYSRTC is running in debug mode	

15.5.5 SYSRTC_CMD - Command Register

Offset	Bit Position																															
0x010	31	30	29	28	27	26	25	24	23	22	21	20	19	18	17	16	15	14	13	12	11	10	9	8	7	6	5	4	3	2	1	0
Reset																															0x0	0x0
Access																															W(nB)	W(nB)
Name																															STOP	START

Bit	Name	Reset	Access	Description
31:2	<i>Reserved</i>	<i>To ensure compatibility with future devices, always write Reserved bits to their reset value, unless otherwise stated. More information in 1.2 Conventions</i>		
1	STOP Write a 1 to stop the SYSRTC	0x0	W(nB)	Stop SYSRTC
0	START Write a 1 to start the SYSRTC	0x0	W(nB)	Start SYSRTC

15.5.6 SYSRTC_STATUS - Status Register

Offset	Bit Position																															
0x014	31	30	29	28	27	26	25	24	23	22	21	20	19	18	17	16	15	14	13	12	11	10	9	8	7	6	5	4	3	2	1	0
Reset																															0x0	0x0
Access																															R	R
Name																															LOCKSTATUS	RUNNING

Bit	Name	Reset	Access	Description
31:2	<i>Reserved</i>	<i>To ensure compatibility with future devices, always write Reserved bits to their reset value, unless otherwise stated. More information in 1.2 Conventions</i>		
1	LOCKSTATUS Indicates the current status of SYSRTC Lock	0x0	R	Lock Status
	Value	Mode		Description
	0	UNLOCKED		SYSRTC registers are unlocked
	1	LOCKED		SYSRTC registers are locked
0	RUNNING Indicates the current status of SYSRTC running	0x0	R	SYSRTC running status

15.5.7 SYSRTC_CNT - Counter Value Register

Offset	Bit Position																															
0x018	31	30	29	28	27	26	25	24	23	22	21	20	19	18	17	16	15	14	13	12	11	10	9	8	7	6	5	4	3	2	1	0
Reset	0x0																															
Access	RW																															
Name	CNT																															

Bit	Name	Reset	Access	Description
31:0	CNT	0x0	RW	Counter Value Gives access to the counter value of the SYSRTC.

15.5.8 SYSRTC_SYNCBUSY - Synchronization Busy Register

Offset	Bit Position																															
0x01C	31	30	29	28	27	26	25	24	23	22	21	20	19	18	17	16	15	14	13	12	11	10	9	8	7	6	5	4	3	2	1	0
Reset																										0x0	0x0	0x0				
Access																										R	R	R				
Name																										CNT	STOP	START				

Bit	Name	Reset	Access	Description
31:3	<i>Reserved</i>	<i>To ensure compatibility with future devices, always write Reserved bits to their reset value, unless otherwise stated. More information in 1.2 Conventions</i>		
2	CNT	0x0	R	Sync busy for CNT bitfield Last writing of CNT is synchronizing to LF clock
1	STOP	0x0	R	Sync busy for STOP bitfield Last writing of STOP is synchronizing to LF clock
0	START	0x0	R	Sync busy for START bitfield Last writing of START is synchronizing to LF clock

15.5.9 SYSRTC_LOCK - Configuration Lock Register

Offset	Bit Position																															
0x020	31	30	29	28	27	26	25	24	23	22	21	20	19	18	17	16	15	14	13	12	11	10	9	8	7	6	5	4	3	2	1	0
Reset																	0x0															
Access																	W															
Name																	LOCKKEY															

Bit	Name	Reset	Access	Description
31:16	<i>Reserved</i>	<i>To ensure compatibility with future devices, always write Reserved bits to their reset value, unless otherwise stated. More information in 1.2 Conventions</i>		
15:0	LOCKKEY	0x0	W	Configuration Lock Key Write any other value than the unlock code to lock EN, SWRST, CFG, CMD, CNT registers from editing. Write the unlock code to unlock.
	Value	Mode	Description	
	18294	UNLOCK	Write to unlock SYSRTC lockable registers	

15.5.10 SYSRTC_GRP0_IF - Group Interrupt Flags

Offset	Bit Position																															
0x040	31	30	29	28	27	26	25	24	23	22	21	20	19	18	17	16	15	14	13	12	11	10	9	8	7	6	5	4	3	2	1	0
Reset																													0x0	0x0	0x0	0x0
Access																													RW	RW	RW	RW
Name																													CAP0	CMP1	CMP0	OVF

Bit	Name	Reset	Access	Description
31:4	<i>Reserved</i>	<i>To ensure compatibility with future devices, always write Reserved bits to their reset value, unless otherwise stated. More information in 1.2 Conventions</i>		
3	CAP0	0x0	RW	Capture 0 Interrupt Flag This bit is set when CAP0VALUE is updated
2	CMP1	0x0	RW	Compare 1 Interrupt Flag This bit is set when counter matches COMP1VALUE
1	CMP0	0x0	RW	Compare 0 Interrupt Flag This bit is set when counter matches COMP0VALUE
0	OVF	0x0	RW	Overflow Interrupt Flag This bit is set when counter overflows

15.5.12 SYSRTC_GRP0_CTRL - Group Control Register

Offset	Bit Position																															
0x048	31	30	29	28	27	26	25	24	23	22	21	20	19	18	17	16	15	14	13	12	11	10	9	8	7	6	5	4	3	2	1	0
Reset											0x0		0x0		0x0		0x0		0x0		0x0		0x0									
Access											RW		RW		RW		RW		RW		RW		RW									
Name											CAP0EDGE		CMP1CMOA		CMP0CMOA		CAP0EN		CMP1EN		CMP0EN											

Bit	Name	Reset	Access	Description
31:11	<i>Reserved</i>	<i>To ensure compatibility with future devices, always write Reserved bits to their reset value, unless otherwise stated. More information in 1.2 Conventions</i>		
10:9	CAP0EDGE	0x0	RW	Capture 0 Edge Select Select edge detection for Capture 0
	Value	Mode		Description
	0	RISING		Rising edges detected
	1	FALLING		Falling edges detected
	2	BOTH		Both edges detected
8:6	CMP1CMOA	0x0	RW	Compare 1 Compare Match Output Action Select PRS output action on Compare 1 match
	Value	Mode		Description
	0	CLEAR		Cleared on the next cycle
	1	SET		Set on the next cycle
	2	PULSE		Set on the next cycle, cleared on the cycle after
	3	TOGGLE		Inverted on the next cycle
	4	CMPIF		Export this channel's CMP IF
5:3	CMP0CMOA	0x0	RW	Compare 0 Compare Match Output Action Select PRS output action on Compare 0 match
	Value	Mode		Description
	0	CLEAR		Cleared on the next cycle
	1	SET		Set on the next cycle
	2	PULSE		Set on the next cycle, cleared on the cycle after
	3	TOGGLE		Inverted on the next cycle
	4	CMPIF		Export this channel's CMP IF
2	CAP0EN	0x0	RW	Capture 0 Enable Set this bit to enable Capture 0

Bit	Name	Reset	Access	Description
1	CMP1EN	0x0	RW	Compare 1 Enable Set this bit to enable Compare 1
0	CMP0EN	0x0	RW	Compare 0 Enable Set this bit to enable Compare 0

15.5.13 SYSRTC_GRP0_CMP0VALUE - Compare 0 Value Register

Offset	Bit Position																															
0x04C	31	30	29	28	27	26	25	24	23	22	21	20	19	18	17	16	15	14	13	12	11	10	9	8	7	6	5	4	3	2	1	0
Reset	0x0																															
Access	RW																															
Name	CMP0VALUE																															

Bit	Name	Reset	Access	Description
31:0	CMP0VALUE	0x0	RW	Compare 0 Value Compare 0 match value

15.5.14 SYSRTC_GRP0_CMP1VALUE - Compare 1 Value Register

Offset	Bit Position																															
0x050	31	30	29	28	27	26	25	24	23	22	21	20	19	18	17	16	15	14	13	12	11	10	9	8	7	6	5	4	3	2	1	0
Reset	0x0																															
Access	RW																															
Name	CMP1VALUE																															

Bit	Name	Reset	Access	Description
31:0	CMP1VALUE	0x0	RW	Compare 1 Value Compare 1 match value

15.5.15 SYSRTC_GRP0_CAP0VALUE - Capture 0 Value Register

Offset	Bit Position																															
0x054	31	30	29	28	27	26	25	24	23	22	21	20	19	18	17	16	15	14	13	12	11	10	9	8	7	6	5	4	3	2	1	0
Reset																0x0																
Access																R																
Name																CAP0VALUE																

Bit	Name	Reset	Access	Description
31:0	CAP0VALUE	0x0	R	Capture 0 Value Capture 0 captured value

15.5.16 SYSRTC_GRP0_SYNCBUSY - Synchronization Busy Register

Offset	Bit Position																															
0x058	31	30	29	28	27	26	25	24	23	22	21	20	19	18	17	16	15	14	13	12	11	10	9	8	7	6	5	4	3	2	1	0
Reset																										0x0	0x0	0x0				
Access																										R	R	R				
Name																										CMP1VALUE	CMP0VALUE	CTRL				

Bit	Name	Reset	Access	Description
31:3	<i>Reserved</i>	<i>To ensure compatibility with future devices, always write Reserved bits to their reset value, unless otherwise stated. More information in 1.2 Conventions</i>		
2	CMP1VALUE	0x0	R	Sync busy for CMP1VALUE register Last writing of CMP1VALUE is synchronizing to LF clock
1	CMP0VALUE	0x0	R	Sync busy for CMP0VALUE register Last writing of CMP0VALUE is synchronizing to LF clock
0	CTRL	0x0	R	Sync busy for CTRL register Last writing of CTRL is synchronizing to LF clock

16. BURTC - Back-Up Real Time Counter

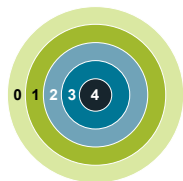

Quick Facts

What?

The BURTC is a 32 bit counter which operates on a low frequency oscillator, and is capable of running in all Energy Modes.

Why?

It can provide periodic Wakeup events and PRS signals which can be used to wake up peripherals from any energy mode.

The availability of the BURTC in EM4, where most of the device is powered down, makes it ideal for keeping track of time in EM4.

How?

The BURTC provides a very wide range of periods for the interrupts facilitating flexible ultra-low energy operation.

16.1 Introduction

The Back-Up Real Time Counter (BURTC) is a 32-bit counter which operates on a low frequency oscillator, and is capable of running in all Energy Modes. It can provide periodic Wakeup events and PRS signals which can be used to wake up peripherals from any energy mode. The BURTC provides a very wide range of periods for the interrupts facilitating flexible ultra-low energy operation. The availability of the BURTC in EM4, where most of the device is powered down, makes it ideal for keeping track of time in EM4. A single compare channel is available which can be used to trigger an interrupt and/or wake the device up from a low energy mode.

16.2 Features

A low frequency oscillator is used as clock signal and the BURTC with one compare channel which can trigger wake-up, generate PRS signalling, or capture system events. 32-bit resolution and selectable prescaling allows the system to stay in low energy modes for long periods of time and still maintain reliable timekeeping.

- 32-bit Real Time Counter
- 15-bit pre-counter for flexible frequency scaling of main counter
- EM2/3/4 operation and wakeup
- Reset only by External Pin and Power-On Resets
- Interrupt/wake up event after deterministic intervals
- PRS Outputs
- Debug mode
 - Configurable to either run or stop when processor is stopped (break)

16.3 Functional Description

An overview of the BURTC module is shown in [Figure 16.1 BURTC Overview on page 458](#).

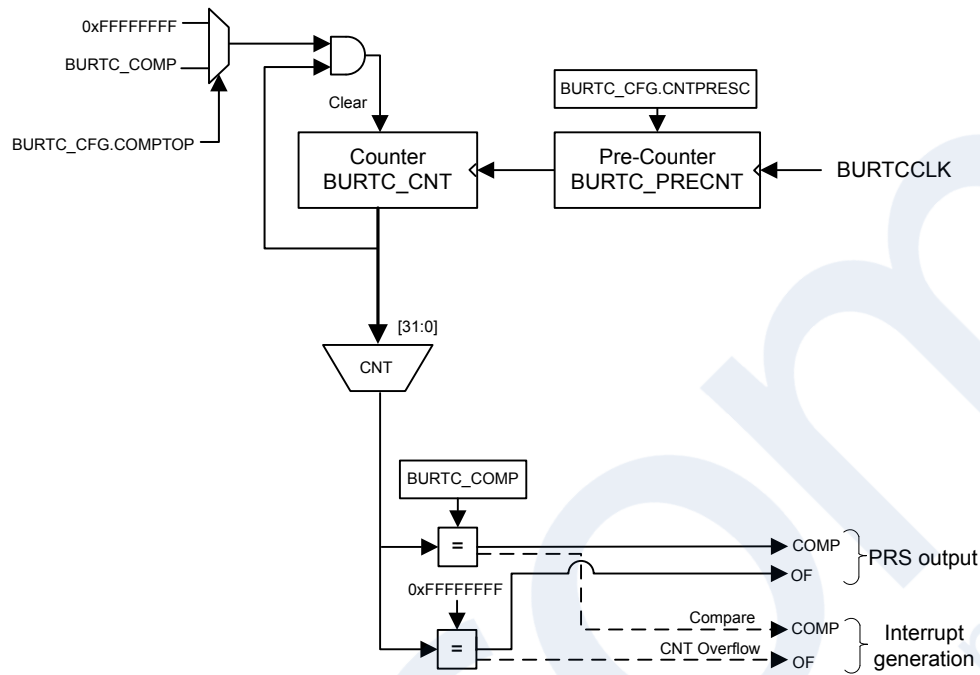

Figure 16.1. BURTC Overview

16.3.1 Clock Selection

The BURTC source clock (BURTCCLK) can be selected to be the LFXO, LFRCO, or ULFRCO by configuring the CMU_EM4GRPACLKCTRL.CLKSEL bitfield. Note that in EM3, only ULFRCO is a valid source clock.

16.3.2 Configuration

To configure and use the BURTC properly, the following programming sequence must be followed:

1. Configure any desired options in the BURTC_CFG register. Note that the BURTC_CFG register can only be written when BURTC_EN.EN = 0 - a bus fault will occur if writing BURTC_CFG register while BURTC_EN.EN = 1.
2. Set BURTC_EN.EN = 1.
3. Set BURTC_CMD.START = 1 to start the BURTC counter.

Note: All low frequency synchronization registers can only be programmed after EN is set to 1. The BURTC counter will only start to count once START command is issued. For HV Sync registers (e.g., BURTC_CMD), the first bitfield write will occur without issue. However, on subsequent bitfield writes to HV Sync registers, the firmware needs to poll the corresponding bit in BURTC_SYNCBUSY before programming the same bitfield once again.

To stop the BURTC, set BURTC_CMD.STOP = 1

16.3.3 Debug Features and Description

By default, the BURTC is halted when code execution is halted from the debugger. By setting the DEBUGRUN bit in the BURTC_CFG register, the BURTC will continue to run even when the debugger has halted the system.

16.3.4 Counter

The BURTC consists of two counters: the 32-bit main counter, BURTC_CNT, and a 15-bit pre-counter, BURTC_PRECNT. The pre-counter is a free running counter clocked by low frequency clock, used to generate a specific frequency for the main counter. The pre-counter will be counting only when the BURTC_CFG.CNTPRESC value is set greater than 0.

The BURTC peripheral clock is requested by setting the EN bit in BURTC_EN. Then the BURTC counters can be started by setting the command register START in BURTC_CMD. When BURTC_CMD.START has been initiated and BURTC_CFG.CNTPRESC > 0, the pre-counter (BURTC_PRECNT) increments upon each positive clock edge of the BURTCCLK, wrapping around to zero when it overflows.

The main counter can be accessed in BURTC_CNT register, and counts at frequency determined by the CNTPRESC bitfield in BURTC_CFG. Setting CNTPRESC to 0 gives the maximum resolution, with the main counter clocked at the same frequency as the BURTCCLK. When CNTPRESC > 0, the main counter increments upon each tick given from the pre-counter, allowing the main counter ticks to be power-of-2 divisions of the BURTCCLK.

The [Table 16.1 BURTC Resolution vs Overflow, \$F_{BURTCCLK} = 32768\$ Hz on page 459](#) table below shows the BURTC Resolution vs Overflow Time when using a 32768 Hz oscillator as the source clock of BURTC.

Table 16.1. BURTC Resolution vs Overflow, $F_{BURTCCLK} = 32768$ Hz

BURTC_CFG.CNTPRESC	Main counter period, T_{CNT}	Overflow Time
DIV1	30.5 μ s	36.4 hours
DIV2	61 μ s	72.8 hours
DIV4	122 μ s	145.6 hours
DIV8	244 μ s	12 days
DIV16	488 μ s	24 days
DIV32	977 μ s	48 days
DIV64	1.95 ms	97 days
DIV128	3.91 ms	194 days
DIV256	7.81 ms	388 days
DIV512	15.6 ms	776 days
DIV1024	31.25 ms	4.2 years
DIV2048	62.5 ms	8.5 years
DIV4096	0.125 s	17 years
DIV8192	0.25 s	34 years
DIV16384	0.5 s	68 years
DIV32768	1 s	136 years

By default, the counter will keep counting until it reaches the top value, 0xFFFFFFFF, and then it wrap around and continue counting from zero. If COMPTOP in BURTC_CFG is set, the main counter will wrap to 0 on a Compare value match (i.e., BURTC_CNT = BURTC_COMP). If using the Compare value match, make sure to set COMPTOP prior to or at the same time the BURTC is enabled. Setting COMPTOP after enabling the BURTC will result in a bus fault error.

The counters of the BURTC, BURTC_CNT and BURTC_PRECNT, can at any time be written by software, as long as the registers are not locked using BURTC_LOCKKEY. All BURTC control registers with Sync Type HV uses the 2 FF synchronization scheme.

Note: Writing to the BURTC_PRECNT register may alter the frequency of the ticks for the BURTC_CNT register.

16.3.5 Compare Channel

A single compare channel is available in the BURTC. The compare value is set in BURTC_COMP register. If BURTC_CFG.COMPTOP is set, the main counter will clear to 0 when it matches the value set in BURTC_COMP.

16.3.6 Interrupts

The BURTC has two interrupts: one for counter overflow and another for the compare match event. Individual interrupts are enabled by BURTC_IEN register bits, and the respective bits can be used as EM2 wakeup. BURTC_EM4WUEN enables the wakeup enable from EM4 for those events.

16.3.7 Register Lock

To prevent accidental writes to the BURTC registers, the BURTC_LOCK register can be written to any other value than the unlock value. To unlock the register, write the unlock value to BURTC_LOCKKEY. Registers affected by this lock are:

- BURTC_CFG
- BURTC_EN
- BURTC_CMD
- BURTC_PRECNT
- BURTC_CNT
- BURTC_COMP
- BURTC_IEN

16.4 BURTC Register Map

The offset register address is relative to the registers base address.

Offset	Name	Type	Description
0x000	BURTC_IPVERSION	R	IP Version ID
0x004	BURTC_EN	RW ENABLE	Module Enable Register
0x008	BURTC_CFG	RW CONFIG	Configuration Register
0x00C	BURTC_CMD	W LFSYNC	Command Register
0x010	BURTC_STATUS	RH	Status Register
0x014	BURTC_IF	RWH INTFLAG	Interrupt Flag Register
0x018	BURTC_IEN	RW	Interrupt Enable Register
0x01C	BURTC_PRECNT	RWH LFSYNC	Pre-Counter Value Register
0x020	BURTC_CNT	RWH LFSYNC	Counter Value Register
0x024	BURTC_EM4WUEN	RW	EM4 Wakeup Request Enable Register
0x028	BURTC_SYNCBUSY	RH	Synchronization Busy Register
0x02C	BURTC_LOCK	W	Configuration Lock Register
0x030	BURTC_COMP	RW LFSYNC	Compare Value Register
0x1000	BURTC_IPVERSION_SET	R	IP Version ID
0x1004	BURTC_EN_SET	RW ENABLE	Module Enable Register
0x1008	BURTC_CFG_SET	RW CONFIG	Configuration Register
0x100C	BURTC_CMD_SET	W LFSYNC	Command Register
0x1010	BURTC_STATUS_SET	RH	Status Register
0x1014	BURTC_IF_SET	RWH INTFLAG	Interrupt Flag Register
0x1018	BURTC_IEN_SET	RW	Interrupt Enable Register
0x101C	BURTC_PRECNT_SET	RWH LFSYNC	Pre-Counter Value Register
0x1020	BURTC_CNT_SET	RWH LFSYNC	Counter Value Register
0x1024	BURTC_EM4WUEN_SET	RW	EM4 Wakeup Request Enable Register
0x1028	BURTC_SYNCBUSY_SET	RH	Synchronization Busy Register
0x102C	BURTC_LOCK_SET	W	Configuration Lock Register
0x1030	BURTC_COMP_SET	RW LFSYNC	Compare Value Register
0x2000	BURTC_IPVERSION_CLR	R	IP Version ID
0x2004	BURTC_EN_CLR	RW ENABLE	Module Enable Register
0x2008	BURTC_CFG_CLR	RW CONFIG	Configuration Register
0x200C	BURTC_CMD_CLR	W LFSYNC	Command Register
0x2010	BURTC_STATUS_CLR	RH	Status Register
0x2014	BURTC_IF_CLR	RWH INTFLAG	Interrupt Flag Register
0x2018	BURTC_IEN_CLR	RW	Interrupt Enable Register
0x201C	BURTC_PRECNT_CLR	RWH LFSYNC	Pre-Counter Value Register
0x2020	BURTC_CNT_CLR	RWH LFSYNC	Counter Value Register

Offset	Name	Type	Description
0x2024	BURTC_EM4WUEN_CLR	RW	EM4 Wakeup Request Enable Register
0x2028	BURTC_SYNCBUSY_CLR	RH	Synchronization Busy Register
0x202C	BURTC_LOCK_CLR	W	Configuration Lock Register
0x2030	BURTC_COMP_CLR	RW LFSYNC	Compare Value Register
0x3000	BURTC_IPVERSION_TGL	R	IP Version ID
0x3004	BURTC_EN_TGL	RW ENABLE	Module Enable Register
0x3008	BURTC_CFG_TGL	RW CONFIG	Configuration Register
0x300C	BURTC_CMD_TGL	W LFSYNC	Command Register
0x3010	BURTC_STATUS_TGL	RH	Status Register
0x3014	BURTC_IF_TGL	RWH INTFLAG	Interrupt Flag Register
0x3018	BURTC_IEN_TGL	RW	Interrupt Enable Register
0x301C	BURTC_PRECNT_TGL	RWH LFSYNC	Pre-Counter Value Register
0x3020	BURTC_CNT_TGL	RWH LFSYNC	Counter Value Register
0x3024	BURTC_EM4WUEN_TGL	RW	EM4 Wakeup Request Enable Register
0x3028	BURTC_SYNCBUSY_TGL	RH	Synchronization Busy Register
0x302C	BURTC_LOCK_TGL	W	Configuration Lock Register
0x3030	BURTC_COMP_TGL	RW LFSYNC	Compare Value Register

16.5 BURTC Register Description

16.5.1 BURTC_IPVERSION - IP Version ID

Offset	Bit Position																															
0x000	31	30	29	28	27	26	25	24	23	22	21	20	19	18	17	16	15	14	13	12	11	10	9	8	7	6	5	4	3	2	1	0
Reset	0x1																															
Access	R																															
Name	IPVERSION																															

Bit	Name	Reset	Access	Description
31:0	IPVERSION	0x1	R	IP Version ID

16.5.2 BURTC_EN - Module Enable Register

Offset	Bit Position																															
0x004	31	30	29	28	27	26	25	24	23	22	21	20	19	18	17	16	15	14	13	12	11	10	9	8	7	6	5	4	3	2	1	0
Reset																													0x0	0x0		
Access																													R	RW		
Name																													DISABLING	EN		

Bit	Name	Reset	Access	Description
31:2	<i>Reserved</i>	<i>To ensure compatibility with future devices, always write Reserved bits to their reset value, unless otherwise stated. More information in 1.2 Conventions</i>		
1	DISABLING	0x0	R	Disablement busy status When EN is cleared, DISABLING is set immediately, and cleared when disablement finishes. Disablement resets peripheral cores and not APB registers except hardware updated registers such as INTFLAGS and FIFOs. The CNT and PRECNT count registers are not reset during disablement.
0	EN	0x0	RW	BURTC Enable Enable the BURTC to make the peripheral clock available to the module

16.5.3 BURTC_CFG - Configuration Register

Offset	Bit Position																															
0x008	31	30	29	28	27	26	25	24	23	22	21	20	19	18	17	16	15	14	13	12	11	10	9	8	7	6	5	4	3	2	1	0
Reset																	0x0					0x0	0x0									
Access																	RW					RW	RW									
Name																	CNTPRESC					COMPTOP	DEBUGRUN									

Bit	Name	Reset	Access	Description
31:8	Reserved	To ensure compatibility with future devices, always write Reserved bits to their reset value, unless otherwise stated. More information in 1.2 Conventions		

7:4	CNTPRESC	0x0	RW	Counter prescaler value. Configure counting frequency of the CNT register
	Value	Mode	Description	
	0	DIV1	CLK_CNT = (BURTC LF CLK)/1	
	1	DIV2	CLK_CNT = (BURTC LF CLK)/2	
	2	DIV4	CLK_CNT = (BURTC LF CLK)/4	
	3	DIV8	CLK_CNT = (BURTC LF CLK)/8	
	4	DIV16	CLK_CNT = (BURTC LF CLK)/16	
	5	DIV32	CLK_CNT = (BURTC LF CLK)/32	
	6	DIV64	CLK_CNT = (BURTC LF CLK)/64	
	7	DIV128	CLK_CNT = (BURTC LF CLK)/128	
	8	DIV256	CLK_CNT = (BURTC LF CLK)/256	
	9	DIV512	CLK_CNT = (BURTC LF CLK)/512	
	10	DIV1024	CLK_CNT = (BURTC LF CLK)/1024	
	11	DIV2048	CLK_CNT = (BURTC LF CLK)/2048	
	12	DIV4096	CLK_CNT = (BURTC LF CLK)/4096	
	13	DIV8192	CLK_CNT = (BURTC LF CLK)/8192	
	14	DIV16384	CLK_CNT = (BURTC LF CLK)/16384	
	15	DIV32768	CLK_CNT = (BURTC LF CLK)/32768	

3:2	Reserved	To ensure compatibility with future devices, always write Reserved bits to their reset value, unless otherwise stated. More information in 1.2 Conventions		
-----	----------	--	--	--

1	COMPTOP	0x0	RW	Compare Channel is Top Value When set, the counter is cleared in the clock cycle after a compare match with compare channel
	Value	Mode	Description	
	0	DISABLE	The top value of the BURTC is 4294967295 (0xFFFFFFFF)	

Bit	Name	Reset	Access	Description
1		ENABLE		The top value of the BURTC is given by COMP
0	DEBUGRUN	0x0	RW	Debug Mode Run Enable Set this bit to enable the BURTC to keep running in debug
	Value	Mode		Description
	0	X0		BURTC is frozen in debug mode
	1	X1		BURTC is running in debug mode

16.5.4 BURTC_CMD - Command Register

Offset	Bit Position																															
0x00C	31	30	29	28	27	26	25	24	23	22	21	20	19	18	17	16	15	14	13	12	11	10	9	8	7	6	5	4	3	2	1	0
Reset																											0x0	0x0				
Access																											W(nB)	W(nB)				
Name																											STOP	START				

Bit	Name	Reset	Access	Description
31:2	Reserved	<i>To ensure compatibility with future devices, always write Reserved bits to their reset value, unless otherwise stated. More information in 1.2 Conventions</i>		
1	STOP	0x0	W(nB)	Stop BURTC counter Write a 1 to stop the BURTC counter.
0	START	0x0	W(nB)	Start BURTC counter Write a 1 to start the BURTC counter.

16.5.5 BURTC_STATUS - Status Register

Offset	Bit Position																															
0x010	31	30	29	28	27	26	25	24	23	22	21	20	19	18	17	16	15	14	13	12	11	10	9	8	7	6	5	4	3	2	1	0
Reset																													0x0	0x0		
Access																													R	R		
Name																													LOCK	RUNNING		

Bit	Name	Reset	Access	Description
31:2	<i>Reserved</i>	<i>To ensure compatibility with future devices, always write Reserved bits to their reset value, unless otherwise stated. More information in 1.2 Conventions</i>		
1	LOCK	0x0	R	Configuration Lock Status Indicates the current status of BURTC Lock
	Value	Mode		Description
	0	UNLOCKED		All BURTC lockable registers are unlocked.
	1	LOCKED		All BURTC lockable registers are locked.
0	RUNNING	0x0	R	BURTC running status Indicates the current status of BURTC running

16.5.6 BURTC_IF - Interrupt Flag Register

Offset	Bit Position																															
0x014	31	30	29	28	27	26	25	24	23	22	21	20	19	18	17	16	15	14	13	12	11	10	9	8	7	6	5	4	3	2	1	0
Reset																													0x0	0x0		
Access																													RW	RW		
Name																													COMP	OF		

Bit	Name	Reset	Access	Description
31:2	<i>Reserved</i>	<i>To ensure compatibility with future devices, always write Reserved bits to their reset value, unless otherwise stated. More information in 1.2 Conventions</i>		
1	COMP	0x0	RW	Compare Match Interrupt Flag Set on a compare match between CNT and COMP.
0	OF	0x0	RW	Overflow Interrupt Flag Set on a CNT value overflow.

16.5.7 BURTC_IEN - Interrupt Enable Register

Offset	Bit Position																															
0x018	31	30	29	28	27	26	25	24	23	22	21	20	19	18	17	16	15	14	13	12	11	10	9	8	7	6	5	4	3	2	1	0
Reset																													0x0	0x0		
Access																													RW	RW		
Name																													COMP	OF		

Bit	Name	Reset	Access	Description
31:2	<i>Reserved</i>	<i>To ensure compatibility with future devices, always write Reserved bits to their reset value, unless otherwise stated. More information in 1.2 Conventions</i>		
1	COMP	0x0	RW	Compare Match Interrupt Flag Set to enable the COMPIF Interrupt
0	OF	0x0	RW	Overflow Interrupt Flag Set to enable the OFIF Interrupt

16.5.8 BURTC_PRECNT - Pre-Counter Value Register

Offset	Bit Position																															
0x01C	31	30	29	28	27	26	25	24	23	22	21	20	19	18	17	16	15	14	13	12	11	10	9	8	7	6	5	4	3	2	1	0
Reset																													0x0	0x0		
Access																													RW	RW		
Name																													PRECNT	PRECNT		

Bit	Name	Reset	Access	Description
31:15	<i>Reserved</i>	<i>To ensure compatibility with future devices, always write Reserved bits to their reset value, unless otherwise stated. More information in 1.2 Conventions</i>		
14:0	PRECNT	0x0	RW	Pre-Counter Value Gives access to the Pre-counter value of the BURTC.

16.5.9 BURTC_CNT - Counter Value Register

Offset	Bit Position																															
0x020	31	30	29	28	27	26	25	24	23	22	21	20	19	18	17	16	15	14	13	12	11	10	9	8	7	6	5	4	3	2	1	0
Reset																															0x0	
Access																															RW	
Name																															CNT	

Bit	Name	Reset	Access	Description
31:0	CNT	0x0	RW	Counter Value Gives access to the counter value of the BURTC.

16.5.10 BURTC_EM4WUEN - EM4 Wakeup Request Enable Register

Offset	Bit Position																															
0x024	31	30	29	28	27	26	25	24	23	22	21	20	19	18	17	16	15	14	13	12	11	10	9	8	7	6	5	4	3	2	1	0
Reset																															0x0	0x0
Access																															RW	RW
Name																															COMP4WUEN	OFEM4WUEN

Bit	Name	Reset	Access	Description
31:2	<i>Reserved</i>	<i>To ensure compatibility with future devices, always write Reserved bits to their reset value, unless otherwise stated. More information in 1.2 Conventions</i>		
1	COMP4WUEN	0x0	RW	Compare Match EM4 Wakeup Enable Compare Match EM4 wakeup requests. No Synchronization done into peripheral clock domain.
0	OFEM4WUEN	0x0	RW	Overflow EM4 Wakeup Enable Overflow EM4 Wakeup request. No Synchronization done into peripheral clock domain.

16.5.11 BURTC_SYNCBUSY - Synchronization Busy Register

Offset	Bit Position																															
0x028	31	30	29	28	27	26	25	24	23	22	21	20	19	18	17	16	15	14	13	12	11	10	9	8	7	6	5	4	3	2	1	0
Reset																											0x0	0x0	0x0	0x0	0x0	
Access																											R	R	R	R	R	
Name																											COMP	CNT	PRECNT	STOP	START	

Bit	Name	Reset	Access	Description
31:5	<i>Reserved</i>	<i>To ensure compatibility with future devices, always write Reserved bits to their reset value, unless otherwise stated. More information in 1.2 Conventions</i>		
4	COMP	0x0	R	Sync busy for COMP Last writing of COMP is synchronizing to LF clock
3	CNT	0x0	R	Sync busy for CNT Last writing of CNT is synchronizing to LF clock
2	PRECNT	0x0	R	Sync busy for PRECNT Last writing of PRECNT is synchronizing to LF clock
1	STOP	0x0	R	Sync busy for STOP Last writing of STOP is synchronizing to LF clock
0	START	0x0	R	Sync busy for START Last writing of START is synchronizing to LF clock

16.5.12 BURTC_LOCK - Configuration Lock Register

Offset	Bit Position																															
0x02C	31	30	29	28	27	26	25	24	23	22	21	20	19	18	17	16	15	14	13	12	11	10	9	8	7	6	5	4	3	2	1	0
Reset																	0xAEE8															
Access																	W															
Name																	LOCKKEY															

Bit	Name	Reset	Access	Description
31:16	Reserved	To ensure compatibility with future devices, always write Reserved bits to their reset value, unless otherwise stated. More information in 1.2 Conventions		
15:0	LOCKKEY	0xAEE8	W	Configuration Lock Key Write any other value than the unlock code to lock BURTC_EN, BURTC_CFG, BURTC_CMD, BURTC_PRECNT, BURTC_CNT and BURTC_COMP registers from editing. Write the unlock code to unlock.
	Value	Mode	Description	
	44776	UNLOCK	Write to unlock all BURTC lockable registers	

16.5.13 BURTC_COMP - Compare Value Register

Offset	Bit Position																															
0x030	31	30	29	28	27	26	25	24	23	22	21	20	19	18	17	16	15	14	13	12	11	10	9	8	7	6	5	4	3	2	1	0
Reset																	0x0															
Access																	RW															
Name																	COMP															

Bit	Name	Reset	Access	Description
31:0	COMP	0x0	RW	Compare Value A compare match event occurs when CNT is equal to this value. This event sets the COMP interrupt flag. It is also available as a PRS signal.

17. BURAM - Backup RAM

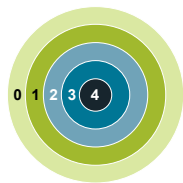

Quick Facts

What?

The BURAM is a dedicated 128-byte low-power RAM that is retained in EM4.

Why?

Most of the system, including the RAM, is powered off at EM4 entry to minimize current draw. The purpose of the BURAM is to retain critical data for use when the system wakes up.

How?

Because it is separate from the main system RAM, the BURAM has a dedicated power supply that is not shutdown when the system enters EM4.

17.1 Introduction

The Back-Up RAM (BURAM) is a dedicated 128-byte RAM that remains powered when the system enters EM4. Upon exit from EM4, the data retained in the BURAM can be accessed by the application software.

17.2 Functional Description

The BURAM consists of 32 x 32-bit registers, which are retained in all energy modes, including EM4. Each word in the BURAM is accessible through the corresponding 32 RETx_REG register. Note that each RETx_REG register has an undefined state out of reset.

17.3 BURAM Register Map

The offset register address is relative to the registers base address.

Offset	Name	Type	Description
0x000	BURAM_RETx_REG	RW	Retention Register
0x1000	BURAM_RETx_REG_SET	RW	Retention Register
0x2000	BURAM_RETx_REG_CLR	RW	Retention Register
0x3000	BURAM_RETx_REG_TGL	RW	Retention Register

17.4 BURAM Register Description

17.4.1 BURAM_RET_x_REG - Retention Register

Offset	Bit Position																															
0x000	31	30	29	28	27	26	25	24	23	22	21	20	19	18	17	16	15	14	13	12	11	10	9	8	7	6	5	4	3	2	1	0
Reset	0x0																															
Access	RW(nB)																															
Name	RETREG																															

Bit	Name	Reset	Access	Description
31:0	RETREG	0x0	RW(nB)	Latch based Retention register The RETREG registers are undefined out of reset. Any written RETREG values will be retained through any event other than a brownout or power-on reset.

18. LETIMER - Low Energy Timer

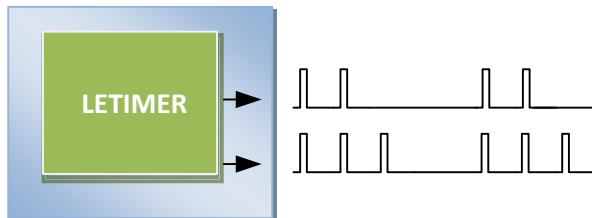
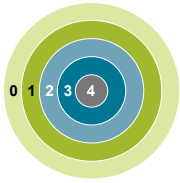

Quick Facts

What?

The LETIMER is a down-counter that can keep track of time and output configurable waveforms. Running on a 32768 Hz clock, the LETIMER is available in EM0 Active, EM1 Sleep, EM2 DeepSleep, and EM3 Stop.

Why?

The LETIMER can be used to provide repeatable waveforms to external components while remaining in EM2 DeepSleep. It is well suited for applications such as metering systems or to provide more compare values than available in the SYSRTC.

How?

With buffered repeat and top value registers, the LETIMER can provide glitch-free waveforms at frequencies up to 16 kHz. It can be coupled with SYSRTC using PRS, allowing advanced time-keeping and wake-up functions in EM2 DeepSleep and EM3 Stop.

18.1 Introduction

The LETIMER is a down-counter that can keep track of time and output configurable waveforms with minimal software intervention. Running on a Low Frequency clock, the LETIMER is available in Energy Mode0, Energy Mode 1 and optionally available in Energy Mode 2 and Energy Mode 3. Because of this, it can be used for timing and output generation when most of the device is powered down, allowing simple tasks to be performed while the power consumption of the system is kept at an absolute minimum. It is well suited for applications such as metering systems or to provide more compare values than available in the SYSRTC. With buffered repeat and top value registers, the LETIMER can provide glitch-free waveforms at frequencies up to 16 kHz. It can be coupled with other peripherals using PRS, allowing advanced time-keeping and wake-up functions.

18.2 Features

High-level features

- 24-bit Down counter
- 8-bit prescaler
- 2 Compare match registers
- TOP register can be Timer top value
- TOP register can be double buffered using TOPBUFF register
- Double buffered 8-bit Repeat Register
- Timer Start/Stop/Clear trigger can be from PRS or Software
- Configurable 2 Output pins - Toggle/Pulse/PWM
- Interrupt - Compare match/Timer underflow/Repeat done
- Optionally runs during debug
- 2 output pins can optionally be configured to provide different waveforms on timer underflow:
 - Toggle output pin
 - Pulse output with width of One Prescaled clock period
 - PWM
- 2 PRS Output

18.3 Functional Description

An overview of the LETIMER module is shown in [Figure 18.1 LETIMER Overview on page 474](#). The LETIMER is a 24-bit down-counter with two compare registers, LETIMERn_COMP0 and LETIMERn_COMP1. The LETIMERn_TOP register can optionally act as a top value for the counter. The repeat counter LETIMERn_REP0 allows the timer to count a specified number of times before it stops. Both the LETIMERn_TOP and LETIMERn_REP0 registers can be double buffered by the LETIMERn_TOPBUFF and LETIMERn_REP1 registers to allow continuous operation. The timer can generate a single pin output, or two linked outputs.

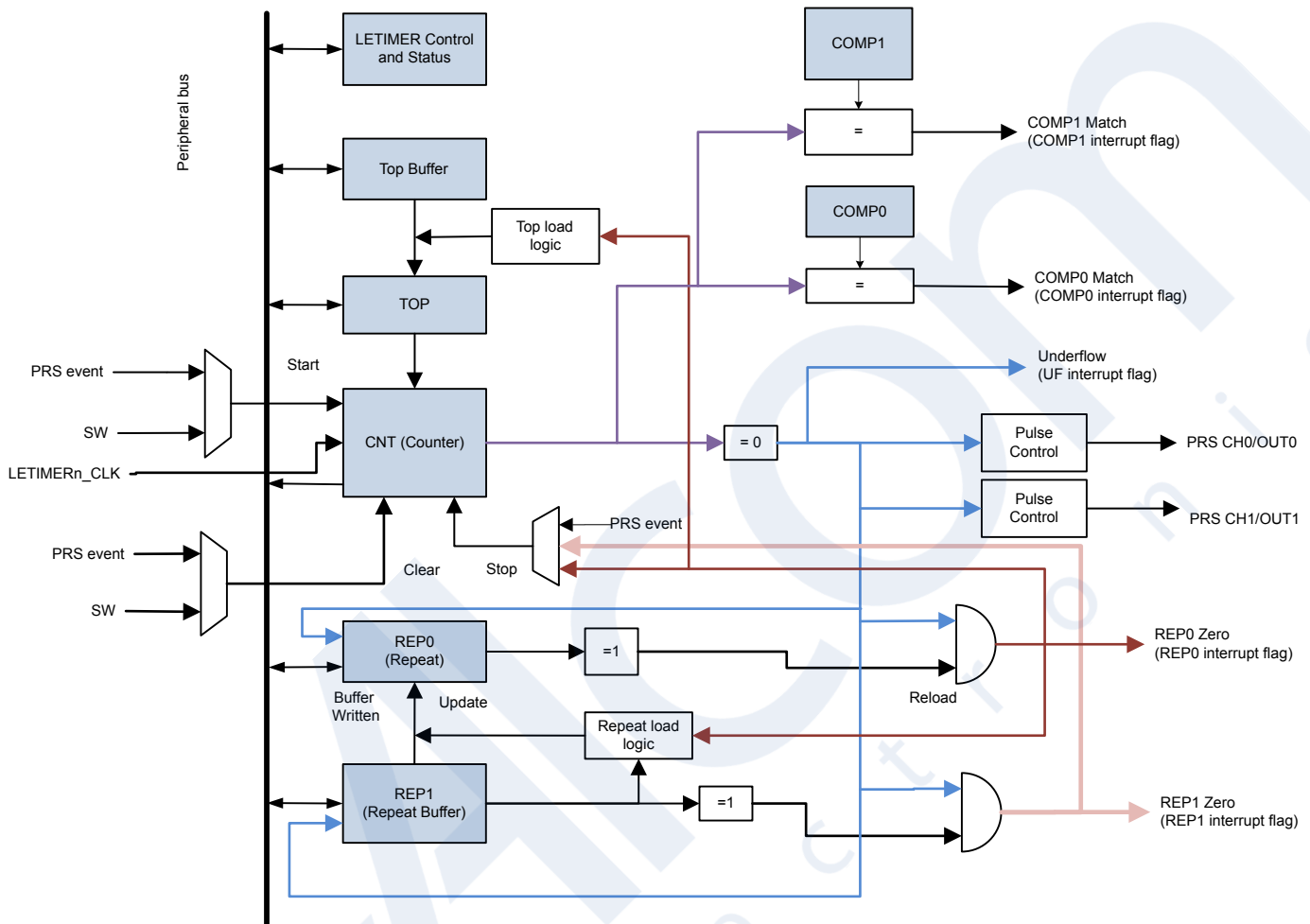

Figure 18.1. LETIMER Overview

18.3.1 Internal Overview

Timer

The timer value can be read using the LETIMERn_CNT register. The value can be written, and it can also be cleared by setting the CLEAR command bit in LETIMERn_CMD. If the CLEAR and START commands are issued at the same time, the timer will be cleared, then start counting at the top value.

Compare Registers

- The LETIMER has two compare match registers, LETIMERn_COMP0 and LETIMERn_COMP1. Each of these compare registers are capable of generating an interrupt when the counter value LETIMERn_CNT is equal to their value. When LETIMERn_CNT is equal to the value of LETIMERn_COMP0, the interrupt flag COMP0 in LETIMERn_IF is set, and when LETIMERn_CNT is equal to the value of LETIMERn_COMP1, the interrupt flag COMP1 in LETIMERn_IF is set.

• Top Value

If CNTTOPEN in LETIMERn_CTRL is set, the value of LETIMERn_TOP acts as the top value of the timer, and LETIMERn_TOP is loaded into LETIMERn_CNT on timer underflow. If CNTTOPEN is cleared to 0, the timer wraps around to 0xFFFFFFFF. The underflow interrupt flag UF in LETIMERn_IF is set when the timer reaches zero.

• Repeat Modes

By default, the timer wraps around to the top value or 0xFFFFFFFF on each underflow, and continues counting. The repeat counters can be used to get more control of the operation of the timer, including defining the number of times the counter should wrap around. Four different repeat modes are available, see [Table 18.1 LETIMER Repeat Modes on page 475](#).

Table 18.1. LETIMER Repeat Modes

REPMODE	Mode	Description
0b00	Free-running	The timer runs until it is stopped.
0b01	One-shot	The timer runs as long as LETIMERn_REP0 != 0. LETIMERn_REP0 is decremented at each timer underflow.
0b10	Buffered	The timer runs as long as LETIMERn_REP0 != 0. LETIMERn_REP0 is decremented on each timer underflow. If LETIMERn_REP1 has been written with Non zero value, then it is loaded into LETIMERn_REP0 when LETIMERn_REP0 is about to be decremented to 0 and Timer continue counting with new LETIMERn_REP0.
0b11	Double	The timer runs as long as LETIMERn_REP0 != 0 or LETIMERn_REP1 != 0. Both LETIMERn_REP0 and LETIMERn_REP1 are decremented at each timer underflow.

The interrupt flags REP0 and REP1 in LETIMERn_IF are set whenever LETIMERn_REP0 or LETIMERn_REP1 are decremented to 0 respectively. REP0 is also set when the value of LETIMERn_REP1 is loaded into LETIMERn_REP0 in buffered mode.

Write operations to LETIMERn_REP0 have priority over buffer loads from LETIMERn_REP1.

• Buffered Top Value

In Buffered Mode, If BUFTOP in LETIMERn_CTRL is set, the value of LETIMERn_TOP is buffered by LETIMERn_TOPBUFF. In this mode, the value of LETIMERn_TOPBUFF is loaded into LETIMERn_TOP every time LETIMERn_REP0 is about to decrement to 0. This can be used to generate continually changing output waveforms.

Write operations to LETIMERn_TOP have priority over buffer loads from LETIMERn__TOPBUFF.

18.3.2 Free Running Mode

In free-running mode, the LETIMER acts as a regular timer and the repeat operation is disabled. When started, the timer runs until it is stopped using the STOP command bit in LETIMERn_CMD/PRS. A state machine for this mode is shown in [Figure 18.2 LETIMER State Machine for Free-running Mode on page 476](#).

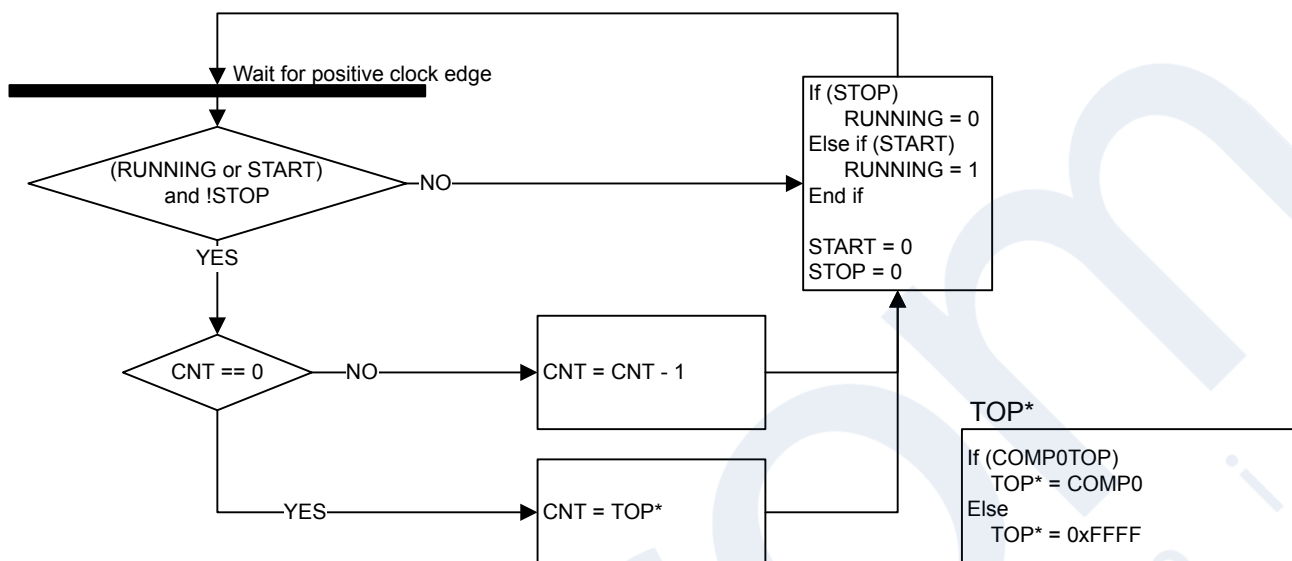

Figure 18.2. LETIMER State Machine for Free-running Mode

Note that the CLEAR command bit in LETIMERn_CMD always has priority over Decrement and Load TOP to LETIMERn_CNT. When the clear command is used, LETIMERn_CNT is set to 0 and an underflow event will not be generated when LETIMERn_CNT wraps around to the top value or 0xFFFFF. Since no underflow event is generated, no output action is performed. LETIMERn_REP0, LETIMERn_REP1, LETIMERn_COMP0 and LETIMERn_COMP1 are also left untouched.

18.3.3 One-shot Mode

The one-shot repeat mode is the most basic repeat mode. In this mode, the repeat register LETIMERn_REP0 is decremented every time the timer underflows, and the timer stops when LETIMERn_REP0 goes from 1 to 0. In this mode, the timer counts down LETIMERn_REP0 times, i.e. the timer underflows LETIMERn_REP0 times.

Note: Note that write operations to LETIMERn_REP0 have priority over the timer decrement event. If LETIMERn_REP0 is assigned a new value in the same cycle as a timer decrement event occurs, the timer decrement will not occur and the new value is assigned.

LETIMERn_REP0 can be written while the timer is running to allow the timer to run for longer periods at a time without stopping. Write to LETIMERn_REP0 should be done after checking SYNC busy status [Figure 18.3 LETIMER One-shot Repeat State Machine on page 477](#).

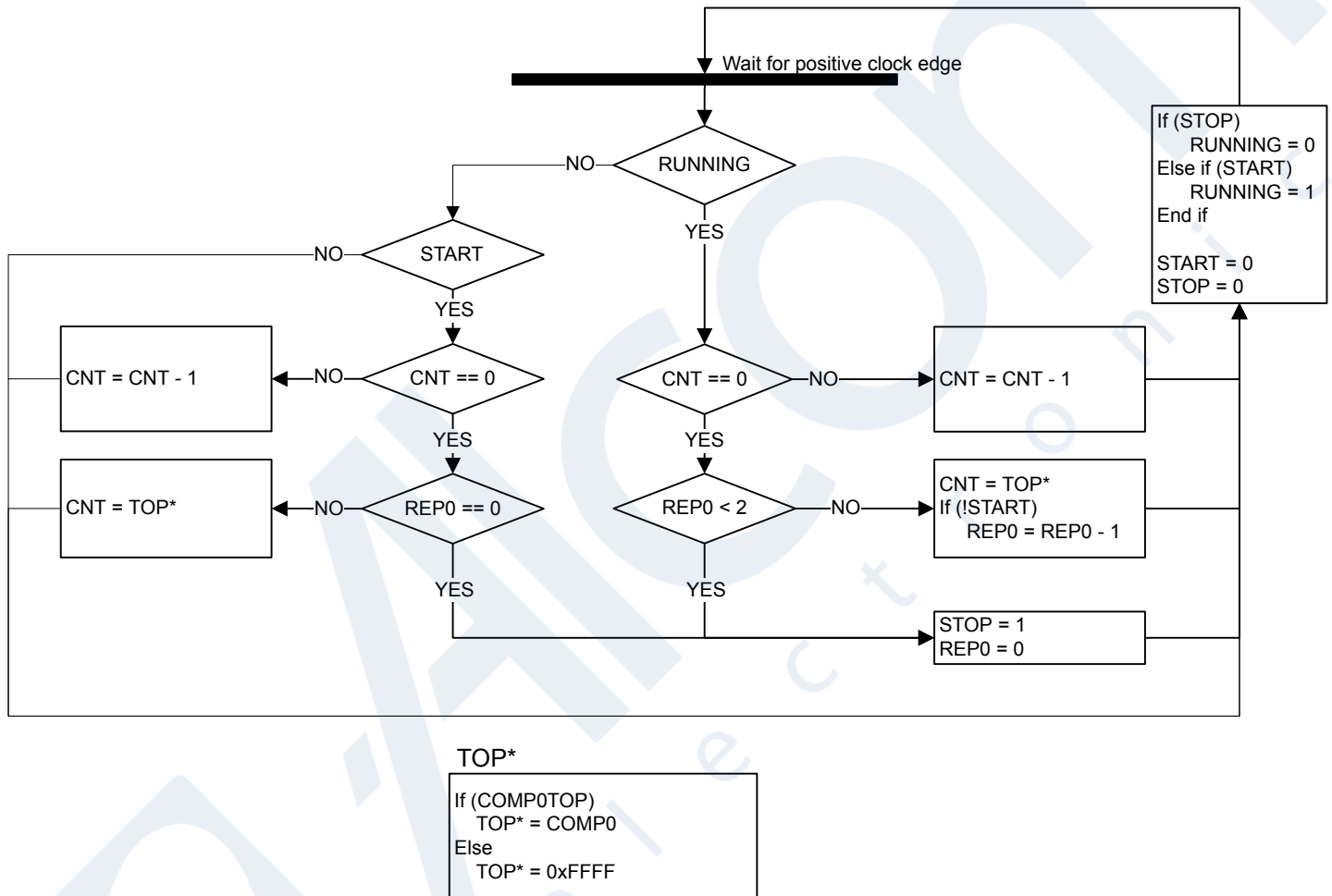

Figure 18.3. LETIMER One-shot Repeat State Machine

18.3.4 Buffered Mode

The Buffered repeat mode allows buffered timer operation. When started, the timer runs LETIMERN_REP0 number of times. If LETIMERN_REP1 has been written since the last time it was used and if it is nonzero, LETIMERN_REP1 is then loaded into LETIMERN_REP0, and counting continues the new number of times. The timer keeps going as long as LETIMERN_REP1 is updated with a nonzero value before LETIMERN_REP0 is finished counting down. The timer top value (LETIMERN_TOP) may also optionally be buffered using Top buff value (LETIMERN_TOPBUFF) by setting BUFTOP in LETIMERN_CTRL.

If the timer is started when both LETIMERN_CNT and LETIMERN_REP0 are zero but LETIMERN_REP1 is non-zero, LETIMERN_REP1 is loaded into LETIMERN_REP0, and the counter counts the loaded number of times.

Used in conjunction with a buffered top value, both the top and repeat values of the timer may be buffered, and the timer can for instance be set to run 4 times with period 7 (top value 6), 6 times with period 200, then 3 times with period 50.

A state machine for the buffered repeat mode is shown in [Figure 18.4 LETIMER Buffered Repeat State Machine on page 478](#). REP1USED shown in the state machine is an internal variable that keeps track of whether the value in LETIMERN_REP1 has been loaded into LETIMERN_REP0 or not. The purpose of this is that a value written to LETIMERN_REP1 should only be counted once. REP1USED is cleared whenever LETIMERN_REP1 is used.

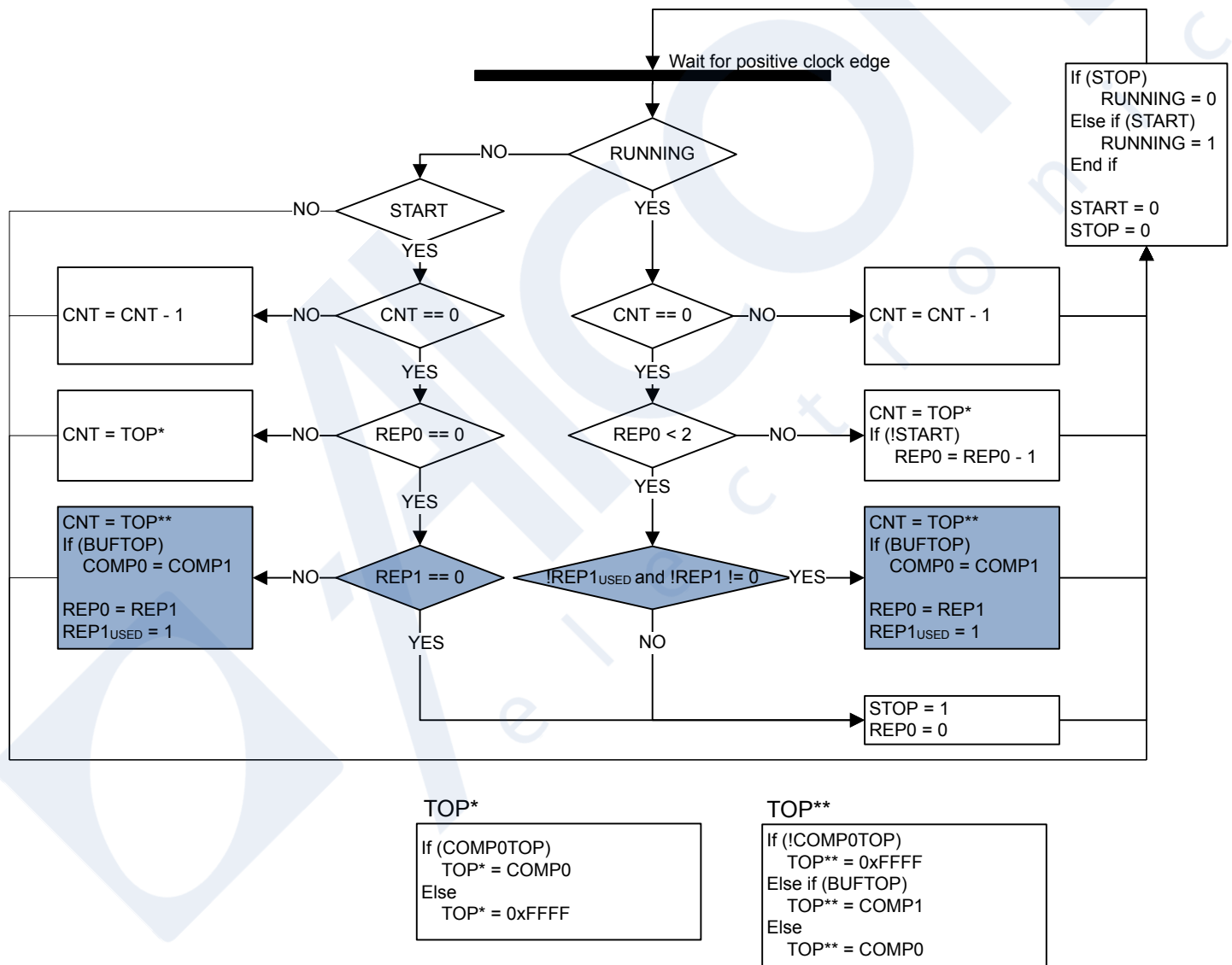

Figure 18.4. LETIMER Buffered Repeat State Machine

18.3.5 Double Mode

The Double repeat mode works much like the one-shot repeat mode. The difference is that, where the one-shot mode counts as long as LETIMERN_REP0 is larger than 0, the double mode counts as long as either LETIMERN_REP0 or LETIMERN_REP1 is larger than 0. As an example, say LETIMERN_REP0 is 3 and LETIMERN_REP1 is 10 when the timer is started. If no further interaction is done with the timer, LETIMERN_REP0 will now be decremented 3 times, and LETIMERN_REP1 will be decremented 10 times. The timer counts a total of 10 times, and LETIMERN_REP0 is 0 after the first three timer underflows and stays at 0. LETIMERN_REP0 and LETIMERN_REP1 can be written at any time. After a write to either of these, the timer is guaranteed to underflow at least the written number of times if the timer is running. Use the Double repeat mode to generate output on both the LETIMER outputs at the same time. The state machine for this repeat mode can be seen in [Figure 18.5 LETIMER Double Repeat State Machine on page 479](#).

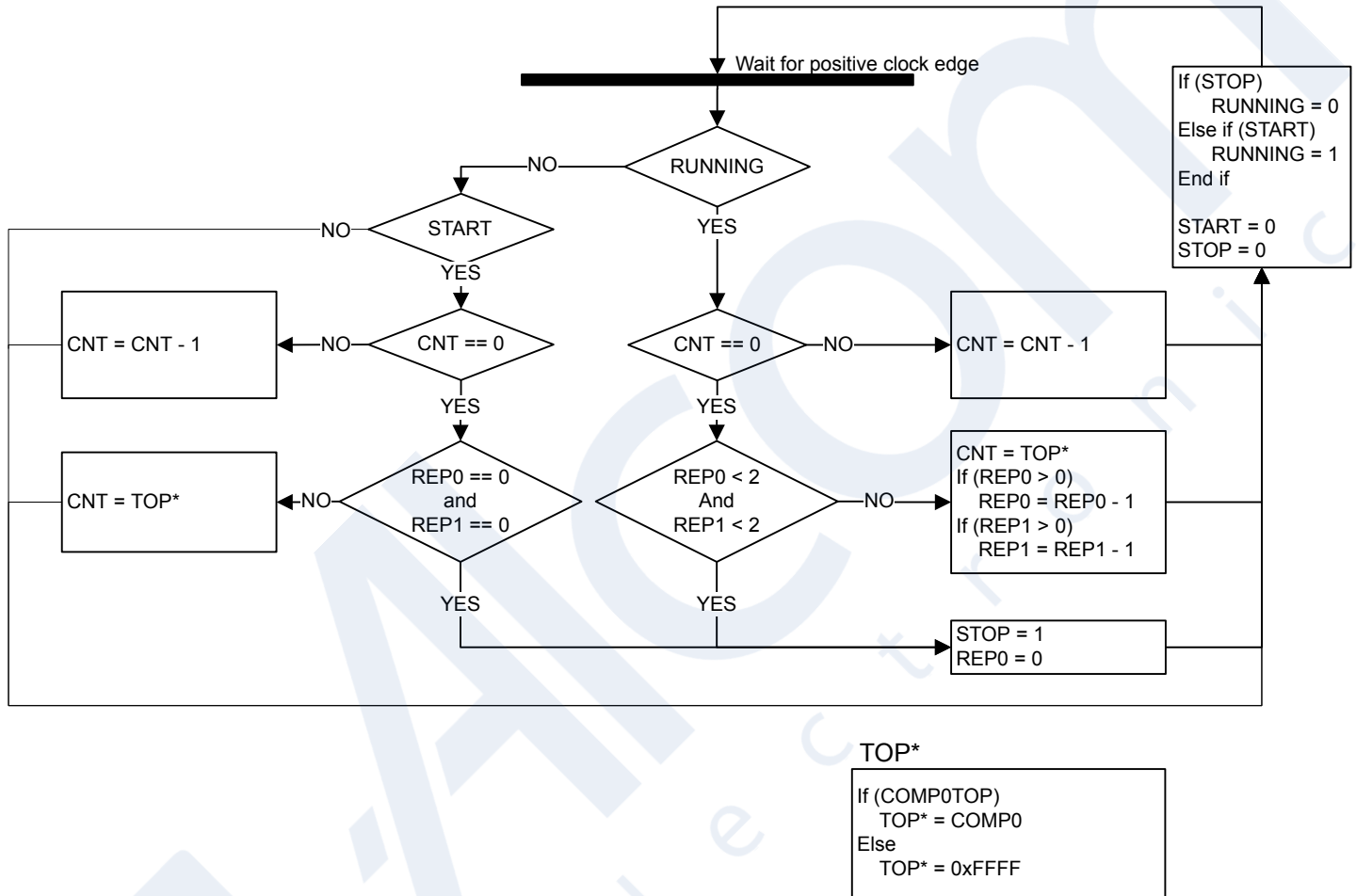

Figure 18.5. LETIMER Double Repeat State Machine

18.4 Clock Frequency

The LETIMER clock source is derived from EM23GRPACLK, which is selected in the Clock Management Unit (CMU), and is typically configured to have a frequency of 32 kHz in EM0/1/2 and 1 kHz in EM3. The LETIMER clock prescaler is defined by LETIMERn_CTRL->CNTPRESC.

The LETIMER Prescaled clock frequency is given by [Figure 18.6 LETIMER Clock Frequency on page 480](#).

EM0/1/2 - Clocked by LFRCO

$$f_{\text{LETIMERn_CLK}} = 32768/2^{\text{CNTPRESC}}$$

EM3 - Clocked by ULFRCO

$$f_{\text{LETIMERn_CLK}} = 1024/2^{\text{CNTPRESC}}$$

Figure 18.6. LETIMER Clock Frequency

The exponent CNTPRESC is a 4 bit value in the LETIMERn_CTRL->CNTPRESC register bits.

To use this module, the LETIMERn_CLK must be enabled by writing 1 to LETIMERn_EN->EN.

18.5 PRS Input Triggers

The LETIMER can be configured to start, stop, and/or clear based on PRS inputs. The diagram showing the functions of the PRS input triggers is shown in [Figure 18.7 LETIMER PRS input triggers. on page 481](#).

There are 3 PRS inputs to the LETIMER, allowing the LETIMER to be started, stopped, or cleared based on the PRS inputs. The PRSSTARTMODE, PRSSTOPMODE, and PRSCLEARMODE bitfields in LETIMERn->PRSMODE select which edge or edge(s) will trigger the start, stop, and/or clear action.

The PRS channel inputs can be configured in the PRS_CONSUMER_LETIMERn_CLEAR, PRS_CONSUMER_LETIMERn_START, and PRS_CONSUMER_LETIMERn_STOP registers in the PRS module.

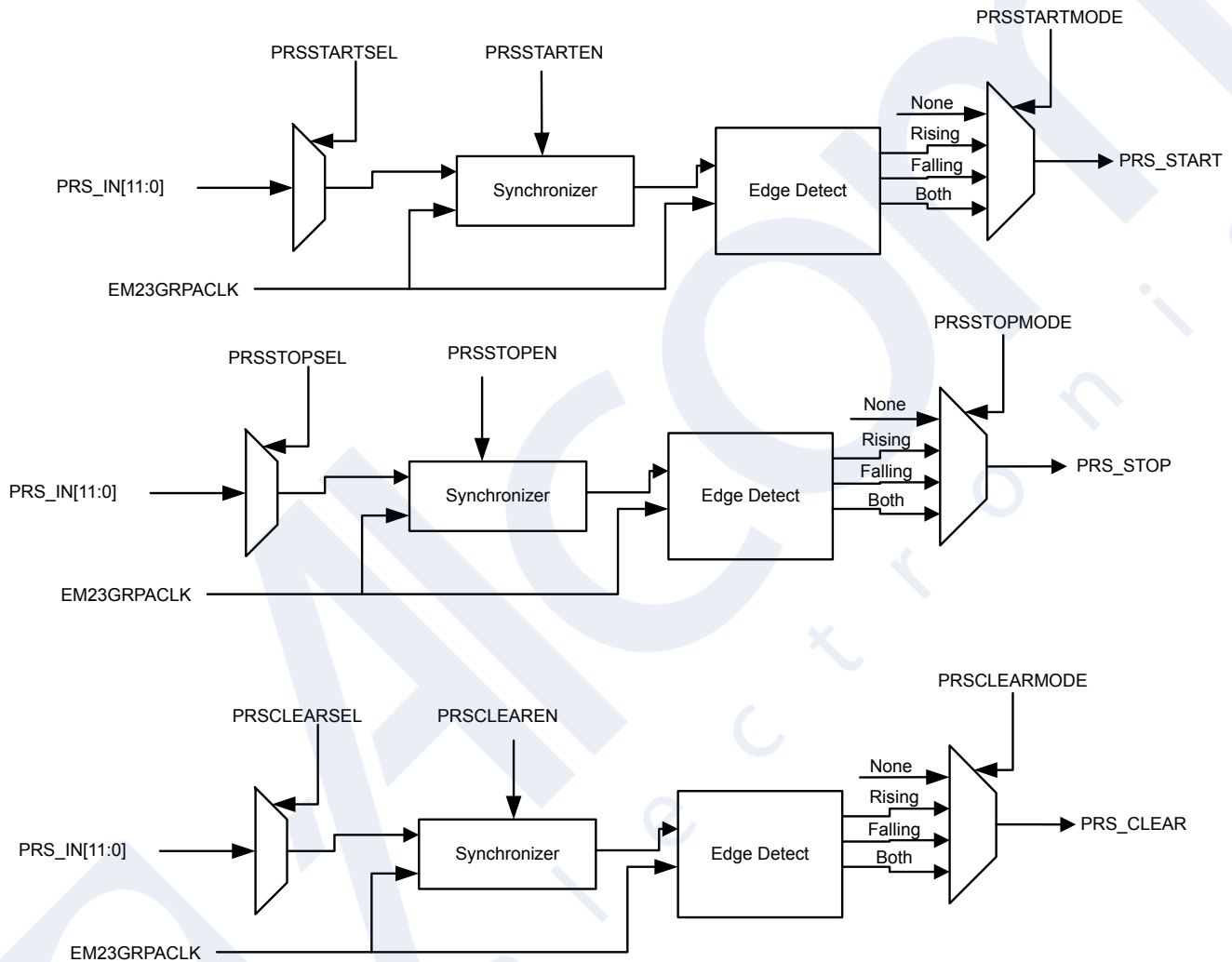

Figure 18.7. LETIMER PRS input triggers.

18.6 Debug

If DEBUGRUN in LETIMERn_CTRL is cleared, the LETIMER automatically stops counting when the CPU is halted during a debug session, and resumes operation when the CPU continues. Because of synchronization, the LETIMER is halted two clock cycles after the CPU is halted, and continues running two clock cycles after the CPU continues. RUNNING in LETIMERn_STATUS is not cleared when the LETIMER stops because of a debug-session.

Set DEBUGRUN in LETIMERn_CTRL to allow the LETIMER to continue counting even when the CPU is halted in debug mode.

18.7 Output Action

For each of the Outputs, an output action can be set.

The output actions can be set by configuring UFOA0 and UFOA1 in LETIMERN_CTRL. UFOA0 defines the action on output 0, while UFOA1 defines the action on output 1. The possible actions are defined in [Table 18.2 LETIMER Underflow Output Actions on page 482](#).

Table 18.2. LETIMER Underflow Output Actions

UFOA0/UFOA1	Mode	Description
0b00	Idle	The output is held at its idle value
0b01	Toggle	The output is toggled on LETIMERN_CNT underflow
0b10	Pulse	The output is held active for one LF clock cycle on LETIMERN_CNT underflow It then returns to its idle value
0b11	PWM	The output is set idle on LETIMERN_CNT underflow and active on compare match with LETIMERN_COMP0/1.

Note: For the Pulse output Disabling LETIMER, Clearing Output while pulse output is generated can affect the pulse width.

Note: For Double mode, OUT0/1 generation is enabled when LETIMERN_REP0/1 != 0 respectively.

The polarity of the outputs can be set individually by configuring OPOL0 and OPOL1 in LETIMERN_CTRL. When these are cleared, their respective outputs have a low idle value and a high active value. When they are set, the idle value is high, and the active value is low. It is recommended to Clear outputs after changing polarity to makesure outputs take their default value.

When using the toggle action, the outputs can be driven to their idle values by setting their respective CTO0/CTO1 command bits in LETIMERN_CTRL. This can be used to put the output in a well-defined state before beginning to generate toggle output, which may be important in some applications. The command bit can also be used while the timer is running.

18.8 PRS Output

The LETIMER outputs can be routed out onto the PRS system. LETn_O0 can be routed to PRS channel 0, and LETn_O1 can be routed to PRS channel 1. Enabling the PRS connection can be done by setting SOURCESEL to LETIMERx and SIGSEL to LETIMERxCHn in PRS_CHx_CTRL.

18.9 Interrupts

The interrupts generated by the LETIMER are combined into one interrupt vector. If the interrupt for the LETIMER is enabled, an interrupt will be made if one or more of the interrupt flags in LETIMERN_IF and their corresponding bits in LETIMER_IEN are set.

18.10 Using the LETIMER in EM3

The LETIMER can be enabled all the way down to EM3 by using the ULFRCO as clock source. This is done by setting CMU_EM23GRPACLKCTRL.CLKSEL to ULFRCO before enabling the LETIMER block.

18.11 Register Access

This module is a Low Energy Peripheral, and supports immediate synchronization. For description regarding immediate synchronization, refer to [4.2.4.4 Peripheral Access Performance](#).

Since this module is a Low Energy Peripheral, and runs off a clock which is asynchronous to the APB register clock, special considerations must be taken when accessing registers.

18.12 Programmer's Model

Important Note : Before writing any LFSYNC register, the module must be enabled (LETIMER_EN->EN) and the LETIMER_SYNCBUSY register should be polled to ensure the SYNC busy of that particular register field is not high.

Write LETIMER Configuration into LETIMER_CTRL Register

Enable clock to LETIMER module by setting LETIMER_EN->EN = 1

If used, write compare values into LETIMER_COMP0 and LETIMER_COMP1

If used, write repeat values into LETIMER_REP0 and LETIMER_REP1

If used, write LETIMER_TOP and LETIMER_TOPBUFF

If PRS is used as a trigger, configure LETIMER_PRSMODE accordingly

Enable Interrupts in LETIMER_IEN

Write LETIMER_CMD register to START Timer

18.12.1 Free Running Mode

LETIMER operation in Free running Mode with different output modes are shown in [Figure 18.8 LETIMER - Free Running Mode Waveform on page 483](#). In this example, REPMODE in LETIMERn_CTRL is set to FREE, CNTTOPEN also in LETIMERn_CTRL has been set and LETIMERn_TOP has been written to 3. As seen in the figure, LETIMERn_TOP now decides the length of the signal periods. For the toggle mode, the period of the output signal is $2(\text{LETIMERn_TOP} + 1)$, and for the pulse modes, the periods of the output signals are $\text{LETIMERn_TOP} + 1$. Note that the pulse outputs are delayed by one period relative to the toggle output. The pulses come at the end of their periods.

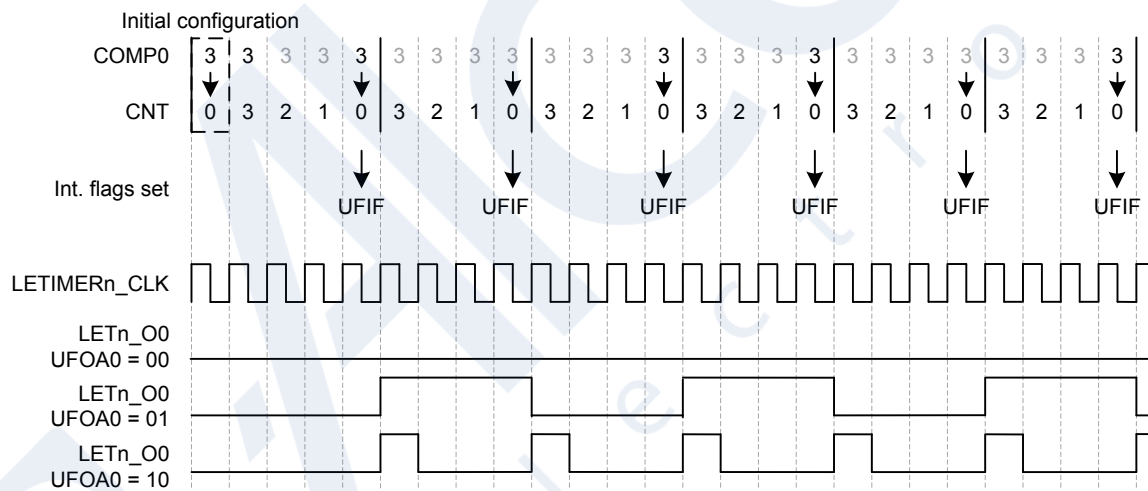

Figure 18.8. LETIMER - Free Running Mode Waveform

18.12.2 One Shot Mode

LETIMER operation in ONESHOT Mode with different output modes are shown in [Figure 18.9 LETIMER - One Shot Mode Waveform on page 484](#). In this example, REPMODE in LETIMERn_CTRL is set to ONESHOT, CNTTOPEN also in LETIMERn_CTRL has been set and LETIMERn_TOP has been written to 3 and LETIMERn_REP0 has been written to 3. The resulting behavior is pretty similar to that shown in Figure 6, but in this case, the timer stops after counting to zero LETIMERn_REP0 times. By using LETIMERn_REP0 the user has full control of the number of pulses/toggles generated on the output.

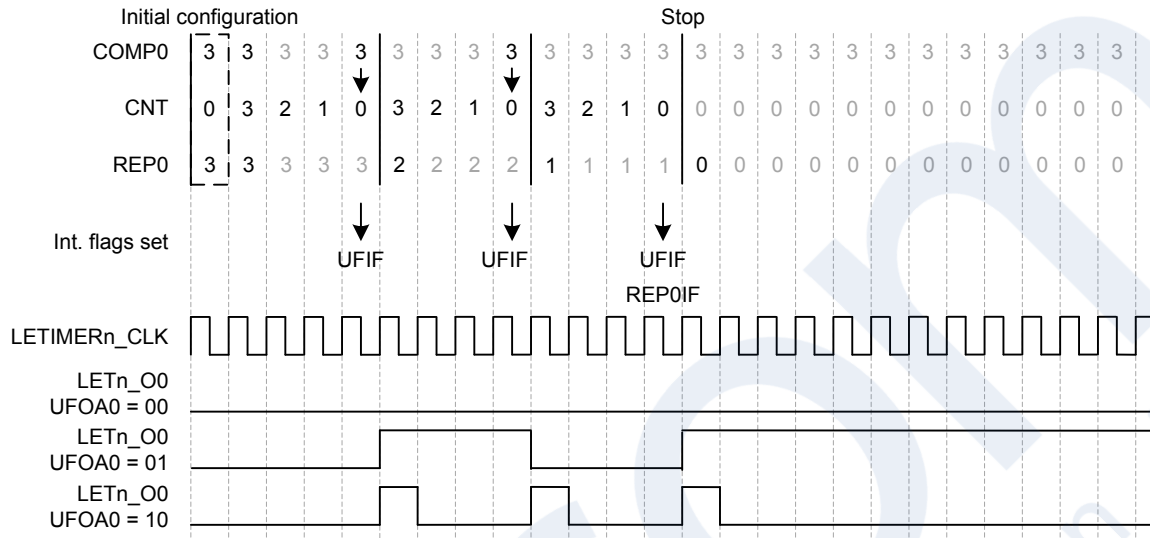

Figure 18.9. LETIMER - One Shot Mode Waveform

18.12.3 DOUBLE Mode

LETIMER operation in DOUBLE Mode with both outputs is shown in [Figure 18.10 LETIMER - Double Mode Waveform on page 484](#). UFOA0 and UFOA1 in LETIMERn_CTRL are configured for pulse output and the outputs are configured for low idle polarity. As seen in the figure, the number written to the repeat registers determine the number of pulses generated on each of the outputs.

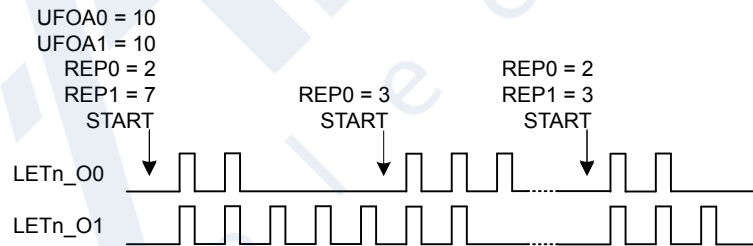

Figure 18.10. LETIMER - Double Mode Waveform

18.12.4 BUFFERED Mode

In BUFFERED Mode LETIMERn_TOPBUFF and LETIMERn_REP1 registers are used as Buffers for LETIMERn_TOP and LETIMERn_REP0 respectively. If both LETIMERn_TOP and LETIMERn_REP0 are 0 in buffered mode, and CNTTOPEN and BUFTOP in LETIMERn_CTRL are set, the values of LETIMERn_TOPBUFF and LETIMERn_REP1 are loaded into LETIMERn_TOP and LETIMERn_REP0 respectively when the timer is started. If no additional writes to LETIMERn_REP1 are done before the timer stops, LETIMERn_REP1 determines the number of pulses/toggles generated on the output, and LETIMERn_TOPBUFF determines the period lengths.

As the SYSRTC can also be used via PRS to start the LETIMER, the SYSRTC and LETIMER can thus be combined to generate specific pulse-trains at given intervals. Software can update LETIMERn_TOPBUFF and LETIMERn_REP1 to change the number of pulses and pulse-period in each train, but if changes are not required, software does not have to update the registers between each pulse train.

For the example in [Figure 18.11 LETIMER - Buffered Mode Waveform on page 485](#), the initial values cause the LETIMER to generate two pulses with 3 cycle periods, or a single pulse 3 cycles wide every time the LETIMER is started. After the output has been generated, the LETIMER stops, and is ready to be triggered again.

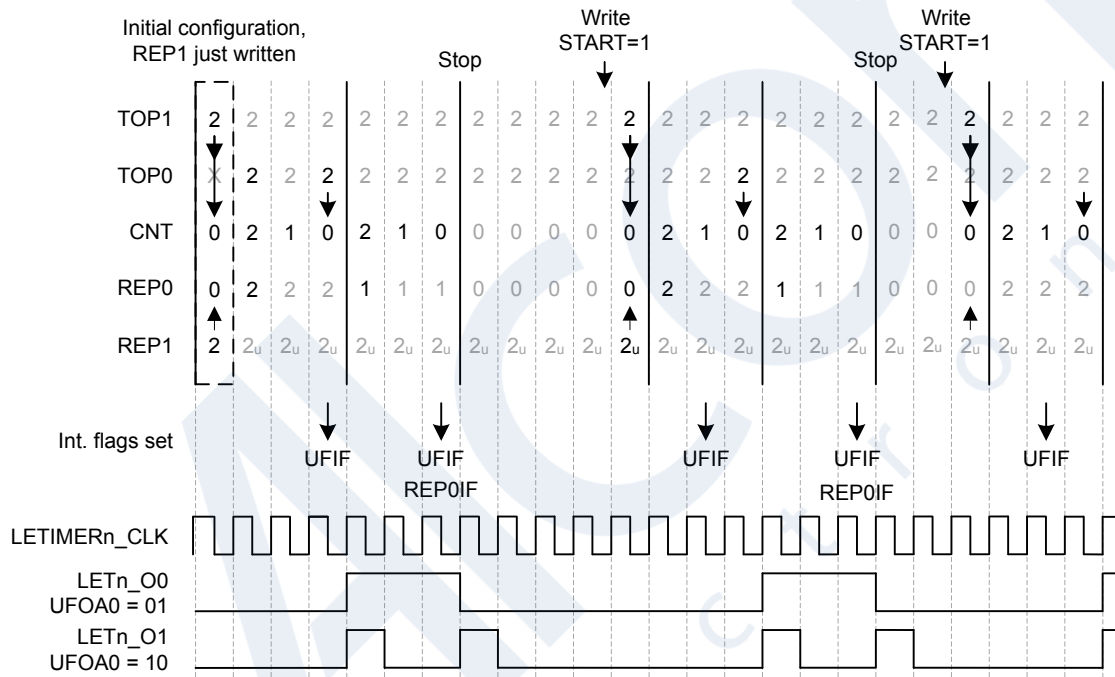

Figure 18.11. LETIMER - Buffered Mode Waveform

18.12.5 Continuous Output Generation

In some scenarios, it might be desired to make LETIMER generate a continuous waveform. Very simple constant waveforms can be generated without the repeat counter as shown in [Figure 18.8 LETIMER - Free Running Mode Waveform on page 483](#), but to generate changing waveforms, using the repeat counter and buffer registers can prove advantageous.

For the example in [Figure 18.12 LETIMER - Continuous Operation on page 486](#), the goal is to produce a pulse train consisting of 3 sequences with the following properties:

- 3 pulses with periods of 3 cycles
- 4 pulses with periods of 2 cycles
- 2 pulses with periods of 3 cycles

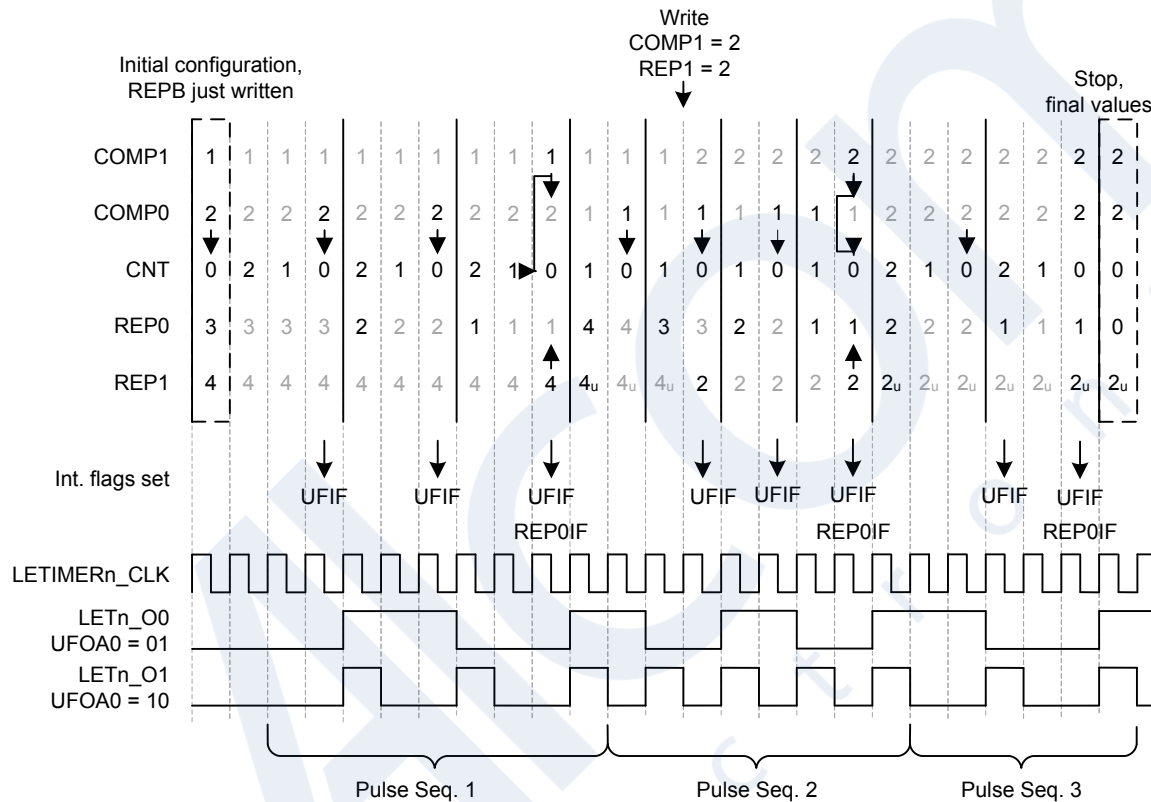

Figure 18.12. LETIMER - Continuous Operation

The first two sequences are loaded into the LETIMER before the timer is started.

LETIMERn_TOP is set to 2 (cycles – 1), and LETIMERn_REP0 is set to 3 for the first sequence, and the second sequence is loaded into the buffer registers, i.e. TOPBUFF is set to 1 and LETIMERn_REP1 is set to 4.

The LETIMER is set to trigger an interrupt when LETIMERn_REP0 is done by setting REP0 in LETIMERn_IEN. This interrupt is a good place to update the values of the buffers. Last but not least REPMODE in LETIMERn_CTRL is set to buffered mode, and the timer is started.

In the interrupt routine the buffers are updated with the values for the third sequence. If this had not been done, the timer would have stopped after the second sequence.

The final result is shown in [Figure 18.12 LETIMER - Continuous Operation on page 486](#). The pulse output is grouped to show which sequence generated which output. Toggle output is also shown in the figure. Note that the toggle output is not aligned with the pulse outputs.

Note: Multiple LETIMER cycles are required to write a value to the LETIMER registers. The example in [Figure 18.12 LETIMER - Continuous Operation on page 486](#) assumes that writes are done in advance so they arrive in the LETIMER as described in the figure.

Figure 18.13 LETIMERn_CNT Not Initialized to 0 on page 487 shows an example where the LETIMER is started while LETIMERn_CNT is nonzero. In this case the length of the first repetition is given by the value in LETIMERn_CNT.

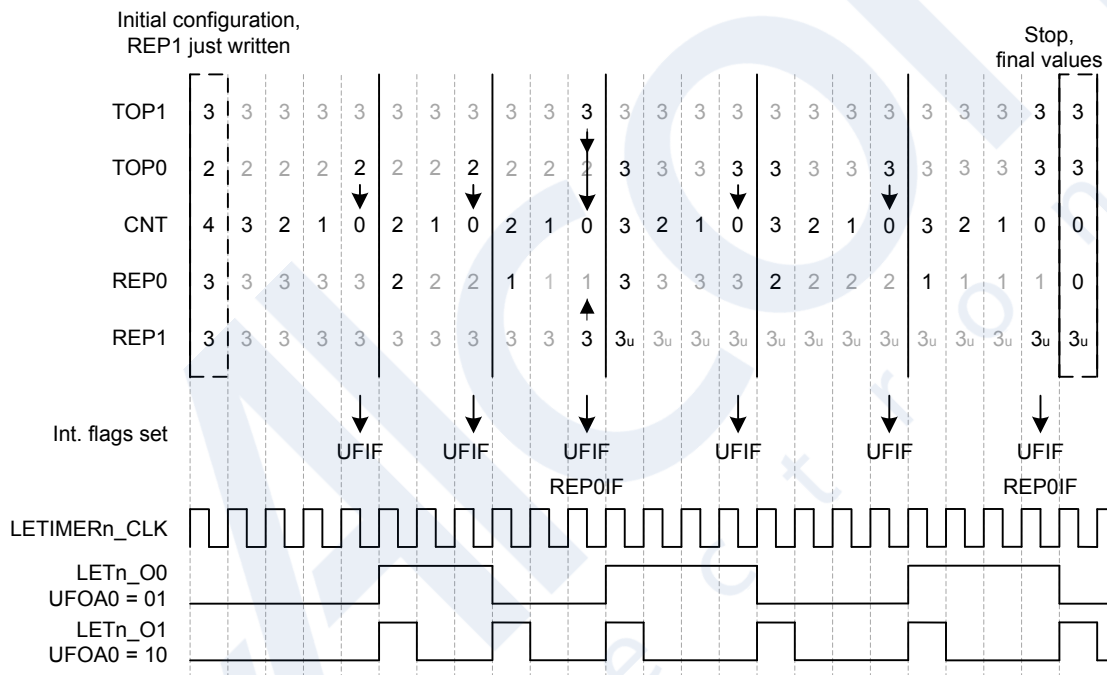

Figure 18.13. LETIMERn_CNT Not Initialized to 0

18.12.6 PWM Output

There are several ways of generating PWM output with the LETIMER, but the most straight-forward way is to use the PWM output mode. This mode is enabled by setting UFOA0 or UFOA1 in LETIMERn_CTRL to 3. In PWM mode, the output is set to idle on timer underflow, and active on LETIMERn_COMP0/1 match, so if for instance CNTTOPEN = 1 and OPOL0 = 0 in LETIMERn_CTRL, LETIMERn_TOP determines the PWM period, and LETIMERn_COMP0/1 determines the active period.

The PWM period in PWM mode is LETIMERn_TOP + 1. There is no special handling of the case where LETIMERn_COMP0/1 > LETIMERn_TOP, so if LETIMERn_COMP0/1 > LETIMERn_TOP, the PWM output is given by the idle output value. This means that for OPOLx = 0 in LETIMERn_CTRL, the PWM output will always be 0 for at least one clock cycle, and for OPOLx = 1 LETIMERn_CTRL, the PWM output will always be 1 for at least one clock cycle.

To generate a PWM signal using the full PWM range, invert OPOLx when LETIMERn_COMP0/1 is set to a value larger than LETIMERn_TOP.

18.13 LETIMER Register Map

The offset register address is relative to the registers base address.

Offset	Name	Type	Description
0x000	LETIMER_IPVERSION	R	IP Version
0x004	LETIMER_EN	RW ENABLE	Module En
0x008	LETIMER_SWRST	RW SWRST	Software Reset Register
0x00C	LETIMER_CTRL	RW	Control Register
0x010	LETIMER_CMD	W LFSYNC	Command Register
0x014	LETIMER_STATUS	RH	Status Register
0x018	LETIMER_CNT	RWH LFSYNC	Counter Value Register
0x01C	LETIMER_COMP0	RW	Compare Value Register 0
0x020	LETIMER_COMP1	RW	Compare Value Register 1
0x024	LETIMER_TOP	RWH LFSYNC	Counter TOP Value Register
0x028	LETIMER_TOPBUFF	RW	Buffered Counter TOP Value
0x02C	LETIMER_REP0	RWH LFSYNC	Repeat Counter Register 0
0x030	LETIMER_REP1	RWH LFSYNC	Repeat Counter Register 1
0x034	LETIMER_IF	RWH INTFLAG	Interrupt Flag Register
0x038	LETIMER_IEN	RW	Interrupt Enable Register
0x03C	LETIMER_LOCK	W	Configuration Lock Register
0x040	LETIMER_SYNCBUSY	RH	Synchronization Busy Register
0x050	LETIMER_PRSMODE	RW	PRS Input Mode Select Register
0x1000	LETIMER_IPVERSION_SET	R	IP Version
0x1004	LETIMER_EN_SET	RW ENABLE	Module En
0x1008	LETIMER_SWRST_SET	RW SWRST	Software Reset Register
0x100C	LETIMER_CTRL_SET	RW	Control Register
0x1010	LETIMER_CMD_SET	W LFSYNC	Command Register
0x1014	LETIMER_STATUS_SET	RH	Status Register
0x1018	LETIMER_CNT_SET	RWH LFSYNC	Counter Value Register
0x101C	LETIMER_COMP0_SET	RW	Compare Value Register 0
0x1020	LETIMER_COMP1_SET	RW	Compare Value Register 1
0x1024	LETIMER_TOP_SET	RWH LFSYNC	Counter TOP Value Register
0x1028	LETIMER_TOPBUFF_SET	RW	Buffered Counter TOP Value
0x102C	LETIMER_REP0_SET	RWH LFSYNC	Repeat Counter Register 0
0x1030	LETIMER_REP1_SET	RWH LFSYNC	Repeat Counter Register 1
0x1034	LETIMER_IF_SET	RWH INTFLAG	Interrupt Flag Register
0x1038	LETIMER_IEN_SET	RW	Interrupt Enable Register
0x103C	LETIMER_LOCK_SET	W	Configuration Lock Register
0x1040	LETIMER_SYNCBUSY_SET	RH	Synchronization Busy Register

Offset	Name	Type	Description
0x1050	LETIMER_PRSMODE_SET	RW	PRS Input Mode Select Register
0x2000	LETIMER_IPVERSION_CLR	R	IP Version
0x2004	LETIMER_EN_CLR	RW ENABLE	Module En
0x2008	LETIMER_SWRST_CLR	RW SWRST	Software Reset Register
0x200C	LETIMER_CTRL_CLR	RW	Control Register
0x2010	LETIMER_CMD_CLR	W LFSYNC	Command Register
0x2014	LETIMER_STATUS_CLR	RH	Status Register
0x2018	LETIMER_CNT_CLR	RWH LFSYNC	Counter Value Register
0x201C	LETIMER_COMP0_CLR	RW	Compare Value Register 0
0x2020	LETIMER_COMP1_CLR	RW	Compare Value Register 1
0x2024	LETIMER_TOP_CLR	RWH LFSYNC	Counter TOP Value Register
0x2028	LETIMER_TOPBUFF_CLR	RW	Buffered Counter TOP Value
0x202C	LETIMER_REP0_CLR	RWH LFSYNC	Repeat Counter Register 0
0x2030	LETIMER_REP1_CLR	RWH LFSYNC	Repeat Counter Register 1
0x2034	LETIMER_IF_CLR	RWH INTFLAG	Interrupt Flag Register
0x2038	LETIMER_IEN_CLR	RW	Interrupt Enable Register
0x203C	LETIMER_LOCK_CLR	W	Configuration Lock Register
0x2040	LETIMER_SYNCBUSY_CLR	RH	Synchronization Busy Register
0x2050	LETIMER_PRSMODE_CLR	RW	PRS Input Mode Select Register
0x3000	LETIMER_IPVERSION_TGL	R	IP Version
0x3004	LETIMER_EN_TGL	RW ENABLE	Module En
0x3008	LETIMER_SWRST_TGL	RW SWRST	Software Reset Register
0x300C	LETIMER_CTRL_TGL	RW	Control Register
0x3010	LETIMER_CMD_TGL	W LFSYNC	Command Register
0x3014	LETIMER_STATUS_TGL	RH	Status Register
0x3018	LETIMER_CNT_TGL	RWH LFSYNC	Counter Value Register
0x301C	LETIMER_COMP0_TGL	RW	Compare Value Register 0
0x3020	LETIMER_COMP1_TGL	RW	Compare Value Register 1
0x3024	LETIMER_TOP_TGL	RWH LFSYNC	Counter TOP Value Register
0x3028	LETIMER_TOPBUFF_TGL	RW	Buffered Counter TOP Value
0x302C	LETIMER_REP0_TGL	RWH LFSYNC	Repeat Counter Register 0
0x3030	LETIMER_REP1_TGL	RWH LFSYNC	Repeat Counter Register 1
0x3034	LETIMER_IF_TGL	RWH INTFLAG	Interrupt Flag Register
0x3038	LETIMER_IEN_TGL	RW	Interrupt Enable Register
0x303C	LETIMER_LOCK_TGL	W	Configuration Lock Register
0x3040	LETIMER_SYNCBUSY_TGL	RH	Synchronization Busy Register
0x3050	LETIMER_PRSMODE_TGL	RW	PRS Input Mode Select Register

18.14 LETIMER Register Description

18.14.1 LETIMER_IPVERSION - IP Version

Offset	Bit Position																															
0x000	31	30	29	28	27	26	25	24	23	22	21	20	19	18	17	16	15	14	13	12	11	10	9	8	7	6	5	4	3	2	1	0
Reset																																0x1
Access																																R
Name																																IPVERSION

Bit	Name	Reset	Access	Description
31:0	IPVERSION	0x1	R	IP Version
The read only IPVERSION field gives the version for this module. There may be minor software changes required for modules with different values of IPVERSION.				

18.14.2 LETIMER_EN - Module En

Offset	Bit Position																															
0x004	31	30	29	28	27	26	25	24	23	22	21	20	19	18	17	16	15	14	13	12	11	10	9	8	7	6	5	4	3	2	1	0
Reset																															0x0	0x0
Access																															R	RW
Name																															DISABLING	EN

Bit	Name	Reset	Access	Description
31:2	<i>Reserved</i>	<i>To ensure compatibility with future devices, always write Reserved bits to their reset value, unless otherwise stated. More information in 1.2 Conventions</i>		
1	DISABLING	0x0	R	Disablement busy status
When EN is cleared, DISABLING is set immediately, and cleared when disablement finishes. Disablement resets peripheral cores and not APB registers except hardware updated registers such as INTFLAGS, FIFOs etc.				
0	EN	0x0	RW	module en
Enable the LETIMER module. Software should write to CONFIG type registers before setting the ENABLE bit. Software should write to SYNC type registers only after setting the ENABLE bit. When EN is cleared(disablement), it halts module operation immediately, and initialize the core domain such that when the is re-enabled, it starts cleanly.				

18.14.3 LETIMER_SWRST - Software Reset Register

Offset	Bit Position																															
0x008	31	30	29	28	27	26	25	24	23	22	21	20	19	18	17	16	15	14	13	12	11	10	9	8	7	6	5	4	3	2	1	0
Reset																															0x0	0x0
Access																															R	W
Name																															RESETTING	SWRST

Bit	Name	Reset	Access	Description
31:2	<i>Reserved</i>	<i>To ensure compatibility with future devices, always write Reserved bits to their reset value, unless otherwise stated. More information in 1.2 Conventions</i>		
1	RESETTING	0x0	R	Software reset busy status When SWRST command is issued, resetting logic sets RESETTING status immediately, and later it is cleared when reset process finishes.
0	SWRST	0x0	W	Software reset command A software reset command field resets the module back to the initial condition, similar to a power on reset condition

18.14.4 LETIMER_CTRL - Control Register

Offset	Bit Position																																				
0x00C	31	30	29	28	27	26	25	24	23	22	21	20	19	18	17	16	15	14	13	12	11	10	9	8	7	6	5	4	3	2	1	0					
Reset													0x0								0x0					0x0	0x0	0x0	0x0	0x0	0x0	0x0	0x0	0x0			
Access													RW								RW					RW	RW	RW	RW	RW	RW	RW	RW	RW	RW	RW	RW
Name													CNTPRESC								DEBUGRUN					CNTTOPEN	BUFTOP	OPOL1	OPOL0	UFOA1	UFOA0	REPMODE					

Bit	Name	Reset	Access	Description
31:20	<i>Reserved</i>	<i>To ensure compatibility with future devices, always write Reserved bits to their reset value, unless otherwise stated. More information in 1.2 Conventions</i>		
19:16	CNTPRESC	0x0	RW	Counter prescaler value Configure counting frequency of the CNT register. - Note - its not recommended to change this setting on the fly.
	Value	Mode	Description	
	0	DIV1	CLK_CNT = (LETIMER LF CLK)/1	
	1	DIV2	CLK_CNT = (LETIMER LF CLK)/2	
	2	DIV4	CLK_CNT = (LETIMER LF CLK)/4	
	3	DIV8	CLK_CNT = (LETIMER LF CLK)/8	
	4	DIV16	CLK_CNT = (LETIMER LF CLK)/16	
	5	DIV32	CLK_CNT = (LETIMER LF CLK)/32	
	6	DIV64	CLK_CNT = (LETIMER LF CLK)/64	
	7	DIV128	CLK_CNT = (LETIMER LF CLK)/128	
	8	DIV256	CLK_CNT = (LETIMER LF CLK)/256	
15:13	<i>Reserved</i>	<i>To ensure compatibility with future devices, always write Reserved bits to their reset value, unless otherwise stated. More information in 1.2 Conventions</i>		
12	DEBUGRUN	0x0	RW	Debug Mode Run Enable Set to keep the LETIMER running in debug mode.
	Value	Mode	Description	
	0	DISABLE	LETIMER is frozen in debug mode	
	1	ENABLE	LETIMER is running in debug mode	
11:10	<i>Reserved</i>	<i>To ensure compatibility with future devices, always write Reserved bits to their reset value, unless otherwise stated. More information in 1.2 Conventions</i>		
9	CNTTOPEN	0x0	RW	Compare Value 0 Is Top Value When set, TOP value will be used as Counter Top Value
	Value	Mode	Description	
	0	DISABLE	The top value of the LETIMER is 65535 (0xFFFF)	

Bit	Name	Reset	Access	Description
	1	ENABLE		The top value of the LETIMER is given by COMP0
8	BUFTOP	0x0	RW	Buffered Top Set to load TOPBUFF into TOP when REP0 reaches 0 in BUFFERED mode, allowing a buffered top value.
	Value	Mode		Description
	0	DISABLE		COMP0 is only written by software
	1	ENABLE		COMP0 is set to COMP1 when REP0 reaches 0
7	OPOL1	0x0	RW	Output 1 Polarity Defines the idle value of output 1.
6	OPOL0	0x0	RW	Output 0 Polarity Defines the idle value of output 0.
5:4	UFOA1	0x0	RW	Underflow Output Action 1 Defines the action on OUT1 on a LETIMER underflow - IDLE/TOGGLE/PULSE/PWM
	Value	Mode		Description
	0	NONE		LETIMERn_OUT1 is held at its idle value as defined by OPOL1
	1	TOGGLE		LETIMERn_OUT1 is toggled on CNT underflow
	2	PULSE		LETIMERn_OUT1 is held active for one LETIMER0 clock cycle on CNT underflow. The output then returns to its idle value as defined by OPOL1
	3	PWM		LETIMERn_OUT1 is set idle on CNT underflow, and active on compare match with COMP1
3:2	UFOA0	0x0	RW	Underflow Output Action 0 Defines the action on OUT0 on a LETIMER underflow - IDLE/TOGGLE/PULSE/PWM
	Value	Mode		Description
	0	NONE		LETIMERn_OUT0 is held at its idle value as defined by OPOL0
	1	TOGGLE		LETIMERn_OUT0 is toggled on CNT underflow
	2	PULSE		LETIMERn_OUT0 is held active for one LETIMER0 clock cycle on CNT underflow. The output then returns to its idle value as defined by OPOL0
	3	PWM		LETIMERn_OUT0 is set idle on CNT underflow, and active on compare match with COMP1
1:0	REPMODE	0x0	RW	Repeat Mode Repeat Mode - FREE/ONESHOT/BUFFERED/DOUBLE
	Value	Mode		Description
	0	FREE		When started, the LETIMER counts down until it is stopped by software
	1	ONESHOT		The counter counts REP0 times. When REP0 reaches zero, the counter stops

Bit	Name	Reset	Access	Description
2		BUFFERED		The counter counts REP0 times. If REP1 has been written, it is loaded into REP0 when REP0 reaches zero, otherwise the counter stops
3		DOUBLE		Both REP0 and REP1 are decremented when the LETIMER wraps around. The LETIMER counts until both REP0 and REP1 are zero

18.14.5 LETIMER_CMD - Command Register

Offset	Bit Position																															
0x010	31	30	29	28	27	26	25	24	23	22	21	20	19	18	17	16	15	14	13	12	11	10	9	8	7	6	5	4	3	2	1	0
Reset																	0x0	0x0	0x0	0x0	0x0											
Access																	W(nB)	W(nB)	W(nB)	W(nB)	W(nB)											
Name																	CTO1	CTO0	CLEAR	STOP	START											

Bit	Name	Reset	Access	Description
31:5	<i>Reserved</i>	<i>To ensure compatibility with future devices, always write Reserved bits to their reset value, unless otherwise stated. More information in 1.2 Conventions</i>		
4	CTO1 Set to drive toggle output 1 to its idle value	0x0	W(nB)	Clear Toggle Output 1
3	CTO0 Set to drive toggle output 0 to its idle value	0x0	W(nB)	Clear Toggle Output 0
2	CLEAR Set to clear LETIMER	0x0	W(nB)	Clear LETIMER
1	STOP Set to stop LETIMER	0x0	W(nB)	Stop LETIMER
0	START Set to start LETIMER	0x0	W(nB)	Start LETIMER

18.14.6 LETIMER_STATUS - Status Register

Offset	Bit Position																															
0x014	31	30	29	28	27	26	25	24	23	22	21	20	19	18	17	16	15	14	13	12	11	10	9	8	7	6	5	4	3	2	1	0
Reset																															0x0	0x0
Access																															R	R
Name																															LETIMERLOCKSTATUS	RUNNING

Bit	Name	Reset	Access	Description
31:2	<i>Reserved</i>	<i>To ensure compatibility with future devices, always write Reserved bits to their reset value, unless otherwise stated. More information in 1.2 Conventions</i>		
1	LETIMERLOCKSTATUS	0x0	R	LETIMER Lock Status Indicates the current status of LETIMER Lock
	Value	Mode		Description
	0	UNLOCKED		LETIMER registers are unlocked
	1	LOCKED		LETIMER registers are locked
0	RUNNING	0x0	R	LETIMER Running Set when LETIMER is running.

18.14.7 LETIMER_CNT - Counter Value Register

Offset	Bit Position																															
0x018	31	30	29	28	27	26	25	24	23	22	21	20	19	18	17	16	15	14	13	12	11	10	9	8	7	6	5	4	3	2	1	0
Reset																															0x0	
Access																															RW	
Name																															CNT	

Bit	Name	Reset	Access	Description
31:24	<i>Reserved</i>	<i>To ensure compatibility with future devices, always write Reserved bits to their reset value, unless otherwise stated. More information in 1.2 Conventions</i>		
23:0	CNT	0x0	RW	Counter Value Use to read the current value of the LETIMER.

18.14.8 LETIMER_COMP0 - Compare Value Register 0

Offset	Bit Position																															
0x01C	31	30	29	28	27	26	25	24	23	22	21	20	19	18	17	16	15	14	13	12	11	10	9	8	7	6	5	4	3	2	1	0
Reset																								0x0								
Access																								RW								
Name																								COMP0								

Bit	Name	Reset	Access	Description
31:24	Reserved	To ensure compatibility with future devices, always write Reserved bits to their reset value, unless otherwise stated. More information in 1.2 Conventions		
23:0	COMP0	0x0	RW	Compare Value 0 Compare value for LETIMER.

18.14.9 LETIMER_COMP1 - Compare Value Register 1

Offset	Bit Position																															
0x020	31	30	29	28	27	26	25	24	23	22	21	20	19	18	17	16	15	14	13	12	11	10	9	8	7	6	5	4	3	2	1	0
Reset																								0x0								
Access																								RW								
Name																								COMP1								

Bit	Name	Reset	Access	Description
31:24	Reserved	To ensure compatibility with future devices, always write Reserved bits to their reset value, unless otherwise stated. More information in 1.2 Conventions		
23:0	COMP1	0x0	RW	Compare Value 1 Compare and optionally buffered top value for LETIMER.

18.14.10 LETIMER_TOP - Counter TOP Value Register

Offset	Bit Position																															
0x024	31	30	29	28	27	26	25	24	23	22	21	20	19	18	17	16	15	14	13	12	11	10	9	8	7	6	5	4	3	2	1	0
Reset									0x0																							
Access									RW																							
Name									TOP																							

Bit	Name	Reset	Access	Description
31:24	Reserved	To ensure compatibility with future devices, always write Reserved bits to their reset value, unless otherwise stated. More information in 1.2 Conventions		
23:0	TOP	0x0	RW	Counter TOP Value TOP will be used as Counter TOP Value if CNTTOPEN is set to 1

18.14.11 LETIMER_TOPBUFF - Buffered Counter TOP Value

Offset	Bit Position																															
0x028	31	30	29	28	27	26	25	24	23	22	21	20	19	18	17	16	15	14	13	12	11	10	9	8	7	6	5	4	3	2	1	0
Reset									0x0																							
Access									RW																							
Name									TOPBUFF																							

Bit	Name	Reset	Access	Description
31:24	Reserved	To ensure compatibility with future devices, always write Reserved bits to their reset value, unless otherwise stated. More information in 1.2 Conventions		
23:0	TOPBUFF	0x0	RW	Buffered Counter TOP Value TOPBUFF will be used as Counter TOP Value in BUFFERED Mode if CNTTOPEN and BUFFTOP is set set to 1

18.14.12 LETIMER_REP0 - Repeat Counter Register 0

Offset	Bit Position																															
0x02C	31	30	29	28	27	26	25	24	23	22	21	20	19	18	17	16	15	14	13	12	11	10	9	8	7	6	5	4	3	2	1	0
Reset																									0x0							
Access																									RW							
Name																									REP0							

Bit	Name	Reset	Access	Description
31:8	Reserved	To ensure compatibility with future devices, always write Reserved bits to their reset value, unless otherwise stated. More information in 1.2 Conventions		
7:0	REP0	0x0	RW	Repeat Counter 0 Optional repeat counter.

18.14.13 LETIMER_REP1 - Repeat Counter Register 1

Offset	Bit Position																															
0x030	31	30	29	28	27	26	25	24	23	22	21	20	19	18	17	16	15	14	13	12	11	10	9	8	7	6	5	4	3	2	1	0
Reset																									0x0							
Access																									RW							
Name																									REP1							

Bit	Name	Reset	Access	Description
31:8	Reserved	To ensure compatibility with future devices, always write Reserved bits to their reset value, unless otherwise stated. More information in 1.2 Conventions		
7:0	REP1	0x0	RW	Repeat Counter 1 Optional repeat counter or buffer for REP0.

18.14.14 LETIMER_IF - Interrupt Flag Register

Offset	Bit Position																																
0x034	31	30	29	28	27	26	25	24	23	22	21	20	19	18	17	16	15	14	13	12	11	10	9	8	7	6	5	4	3	2	1	0	
Reset																												0x0	0x0	0x0	0x0	0x0	0x0
Access																												RW	RW	RW	RW	RW	RW
Name																												REP1	REP0	UF	COMP1	COMP0	

Bit	Name	Reset	Access	Description
31:5	<i>Reserved</i>	<i>To ensure compatibility with future devices, always write Reserved bits to their reset value, unless otherwise stated. More information in 1.2 Conventions</i>		
4	REP1	0x0	RW	Repeat Counter 1 Interrupt Flag Set when repeat counter 1 reaches zero.
3	REP0	0x0	RW	Repeat Counter 0 Interrupt Flag Set when repeat counter 0 reaches zero or when the REP1 interrupt flag is loaded into the REP0 interrupt flag.
2	UF	0x0	RW	Underflow Interrupt Flag Set on LETIMER underflow.
1	COMP1	0x0	RW	Compare Match 1 Interrupt Flag Set when LETIMER reaches the value of COMP1.
0	COMP0	0x0	RW	Compare Match 0 Interrupt Flag Set when LETIMER reaches the value of COMP0.

18.14.15 LETIMER_IEN - Interrupt Enable Register

Offset	Bit Position																															
0x038	31	30	29	28	27	26	25	24	23	22	21	20	19	18	17	16	15	14	13	12	11	10	9	8	7	6	5	4	3	2	1	0
Reset																																
Access																																
Name																																

Bit	Name	Reset	Access	Description
31:5	<i>Reserved</i>	<i>To ensure compatibility with future devices, always write Reserved bits to their reset value, unless otherwise stated. More information in 1.2 Conventions</i>		
4	REP1 Repeat Counter 1 Interrupt Enable	0x0	RW	Repeat Counter 1 Interrupt Enable
3	REP0 Repeat Counter 0 Interrupt Enable	0x0	RW	Repeat Counter 0 Interrupt Enable
2	UF Underflow Interrupt Enable	0x0	RW	Underflow Interrupt Enable
1	COMP1 Compare Match 1 Interrupt Enable	0x0	RW	Compare Match 1 Interrupt Enable
0	COMP0 Compare Match 0 Interrupt Enable	0x0	RW	Compare Match 0 Interrupt Enable

18.14.16 LETIMER_LOCK - Configuration Lock Register

Offset	Bit Position																															
0x03C	31	30	29	28	27	26	25	24	23	22	21	20	19	18	17	16	15	14	13	12	11	10	9	8	7	6	5	4	3	2	1	0
Reset																	0x0															
Access																	W															
Name																	LETIMERLOCKKEY															

Bit	Name	Reset	Access	Description
31:16	<i>Reserved</i>	<i>To ensure compatibility with future devices, always write Reserved bits to their reset value, unless otherwise stated. More information in 1.2 Conventions</i>		
15:0	LETIMERLOCKKEY	0x0	W	Configuration Lock Key Write any other value than the unlock code to lock LETIMER_EN, LETIMER_SWRST, LETIMER_CTRL, LETIMER_CMD, LETIMER_CNT, LETIMER_COMP0, LETIMER_COMP1, LETIMER_TOP, LETIMER_TOPBUFF, LETIMER_REP0, LETIMER_REP1 and PRSMODE registers from editing. Write the unlock code to unlock.
	Value	Mode	Description	
	52476	UNLOCK	Write to unock LETIMER lockable registers	

18.14.17 LETIMER_SYNCBUSY - Synchronization Busy Register

Offset	Bit Position																																																					
0x040	31	30	29	28	27	26	25	24	23	22	21	20	19	18	17	16	15	14	13	12	11	10	9	8	7	6	5	4	3	2	1	0																						
Reset																							0x0	0x0	0x0	0x0	0x0	0x0	0x0	0x0	0x0	0x0	0x0	0x0	0x0	0x0	0x0	0x0	0x0	0x0	0x0	0x0	0x0	0x0	0x0	0x0	0x0	0x0	0x0	0x0	0x0	0x0	0x0	
Access																							R	R	R	R	R	R	R	R	R	R	R	R	R	R	R	R	R	R	R	R	R	R	R	R	R	R	R	R	R	R	R	R
Name																							CTO1	CTO0	CLEAR	STOP	START	REP1	REP0	TOP																							CNT	

Bit	Name	Reset	Access	Description
31:10	<i>Reserved</i>	<i>To ensure compatibility with future devices, always write Reserved bits to their reset value, unless otherwise stated. More information in 1.2 Conventions</i>		
9	CTO1 Sync busy for CTO1	0x0	R	Sync busy for CTO1
8	CTO0 Sync busy for CTO0	0x0	R	Sync busy for CTO0
7	CLEAR Sync busy for CLEAR	0x0	R	Sync busy for CLEAR
6	STOP Sync busy for STOP	0x0	R	Sync busy for STOP
5	START Sync busy for START	0x0	R	Sync busy for START
4	REP1 Sync busy for REP1	0x0	R	Sync busy for REP1
3	REP0 Sync busy for REP0	0x0	R	Sync busy for REP0
2	TOP Sync busy for TOP	0x0	R	Sync busy for TOP
1	<i>Reserved</i>	<i>To ensure compatibility with future devices, always write Reserved bits to their reset value, unless otherwise stated. More information in 1.2 Conventions</i>		
0	CNT Sync busy for CNT	0x0	R	Sync busy for CNT

18.14.18 LETIMER_PRSMODE - PRS Input Mode Select Register

Offset	Bit Position																															
0x050	31	30	29	28	27	26	25	24	23	22	21	20	19	18	17	16	15	14	13	12	11	10	9	8	7	6	5	4	3	2	1	0
Reset					0x0					0x0					0x0																	
Access					RW					RW					RW																	
Name					PRSCLEARMODE					PRSSTOPMODE					PRSSTARTMODE																	

Bit	Name	Reset	Access	Description
31:28	<i>Reserved</i>	<i>To ensure compatibility with future devices, always write Reserved bits to their reset value, unless otherwise stated. More information in 1.2 Conventions</i>		
27:26	PRSCLEARMODE	0x0	RW	PRS Clear Mode
	Mode-NONE/RISING/FALLING/BOTH			
	Value	Mode	Description	
	0	NONE	PRS cannot clear the LETIMER	
	1	RISING	Rising edge of selected PRS input can clear the LETIMER	
	2	FALLING	Falling edge of selected PRS input can clear the LETIMER	
	3	BOTH	Both the rising or falling edge of the selected PRS input can clear the LETIMER	
25:24	<i>Reserved</i>	<i>To ensure compatibility with future devices, always write Reserved bits to their reset value, unless otherwise stated. More information in 1.2 Conventions</i>		
23:22	PRSSTOPMODE	0x0	RW	PRS Stop Mode
	Mode-NONE/RISING/FALLING/BOTH			
	Value	Mode	Description	
	0	NONE	PRS cannot stop the LETIMER	
	1	RISING	Rising edge of selected PRS input can stop the LETIMER	
	2	FALLING	Falling edge of selected PRS input can stop the LETIMER	
	3	BOTH	Both the rising or falling edge of the selected PRS input can stop the LETIMER	
21:20	<i>Reserved</i>	<i>To ensure compatibility with future devices, always write Reserved bits to their reset value, unless otherwise stated. More information in 1.2 Conventions</i>		
19:18	PRSSTARTMODE	0x0	RW	PRS Start Mode
	Mode-NONE/RISING/FALLING/BOTH			
	Value	Mode	Description	
	0	NONE	PRS cannot start the LETIMER	
	1	RISING	Rising edge of selected PRS input can start the LETIMER	

Bit	Name	Reset	Access	Description
2		FALLING		Falling edge of selected PRS input can start the LETIMER
3		BOTH		Both the rising or falling edge of the selected PRS input can start the LETIMER
17:0	Reserved	<i>To ensure compatibility with future devices, always write Reserved bits to their reset value, unless otherwise stated. More information in 1.2 Conventions</i>		

19. TIMER - Timer/Counter

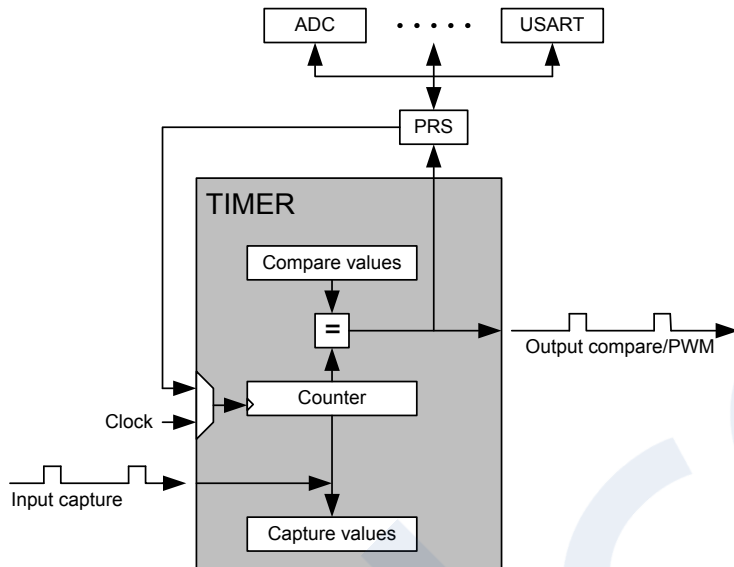
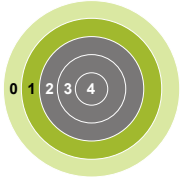

Quick Facts

What?

The TIMER (Timer/Counter) keeps track of timing and counts events, generates output waveforms, and triggers timed actions in other peripherals.

Why?

Most applications have activities that need to be timed accurately with as little CPU intervention and energy consumption as possible.

How?

The flexible 16/32-bit timer can be configured to provide PWM waveforms with optional dead-time insertion (e.g. motor control) or work as a frequency generator. The timer can also count events and control other peripherals through the PRS, which offloads the CPU and reduces energy consumption.

19.1 Introduction

The general purpose timer has 3 or 4 compare/capture channels for input capture and compare/Pulse-Width Modulation (PWM) output.

The TIMER module may be 16 or 32 bits wide. Some timers also include a Dead-Time Insertion module suitable for motor control applications.

Refer to the device data sheet to determine the capabilities (capture/compare channel count, width, and DTI) of each timer instance.

19.2 Features

- 16/32-bit auto reload up/down counter
 - Dedicated 16/32-bit reload register which serves as counter maximum
- 3 or 4 Compare/Capture channels
 - Individually configurable as either input capture or output compare/PWM
- Multiple Counter modes
 - Count up
 - Count down
 - Count up/down
 - Quadrature Decoder
 - Direction and count from external pins
- 2x Count Mode
- Counter control from PRS or external pin
 - Start
 - Stop
 - Reload and start
- Inter-Timer connection
 - Allows 32-bit counter mode
 - Start/stop synchronization between several timers
- Input Capture
 - Period measurement
 - Pulse width measurement
 - Two capture registers for each capture channel
 - Capture on either positive or negative edge
 - Capture on both edges
 - Optional digital noise filtering on capture inputs
- Output Compare
 - Compare output toggle/pulse on compare match
 - Immediate update of compare registers
- PWM
 - Up-count PWM
 - Up/down-count PWM
 - Predictable initial PWM output state (configured by SW)
 - Buffered compare register to ensure glitch-free update of compare values
 - Output re-timing to mitigate RF interference
- Clock sources
 - HFPERCLK_{TIMERN}
 - 10-bit Prescaler
 - External pin
 - Peripheral Reflex System
- Debug mode
 - Configurable to either run or stop when processor is stopped (halt/breakpoint)
- Interrupts, PRS output and/or DMA request on:
 - Underflow
 - Overflow
 - Compare/Capture event

- Dead-Time Insertion Unit
 - Complementary PWM outputs with programmable dead-time
 - Dead-time is specified independently for rising and falling edge
 - 10-bit prescaler
 - 6-bit time value
 - Outputs have configurable polarity
 - Outputs can be set inactive individually by software.
 - Configurable action on fault
 - Set outputs inactive
 - Clear output
 - Tristate output
 - Individual fault sources
 - One or two PRS signals
 - Debugger
 - Support for automatic restart
 - Core lockup
 - EM2/EM3 entry
 - Configuration lock

19.3 Functional Description

An overview of the TIMER module is shown in [Figure 19.1 TIMER Block Overview on page 507](#) and it consists of a 16/32 bit up/down counter with 3 compare/capture channels connected to pins TIMn_CC0, TIMn_CC1, and TIMn_CC2.

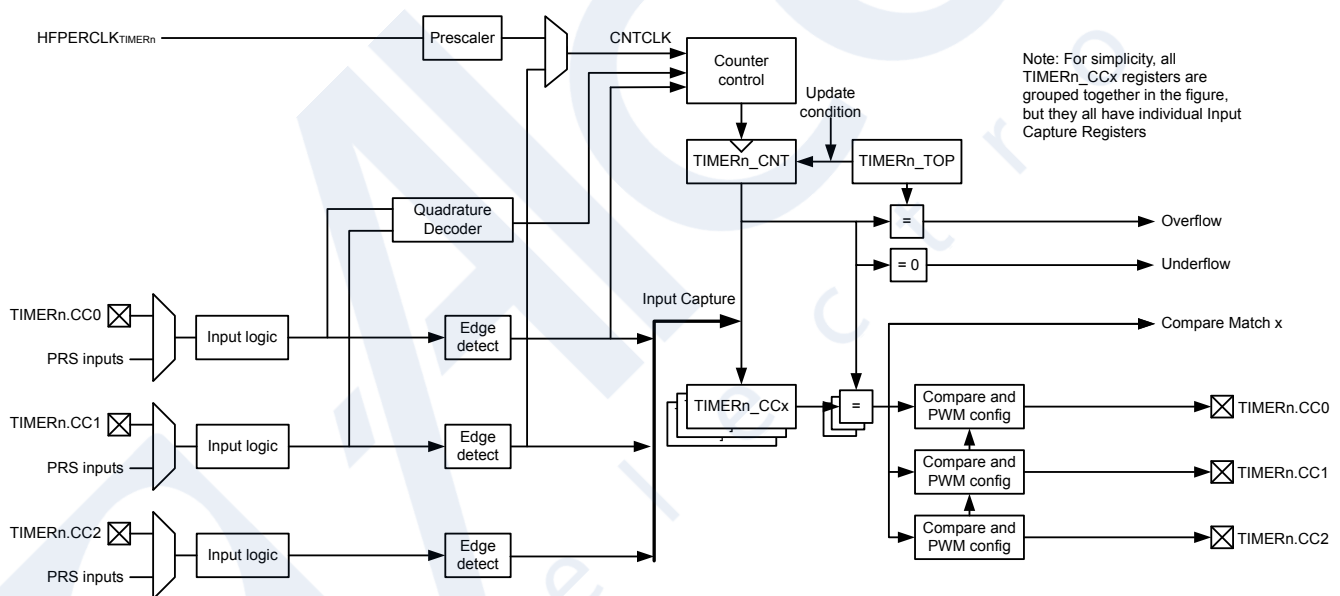

Figure 19.1. TIMER Block Overview

19.3.1 Register Access

The timer module interface consists of multiple register types. Registers of type "RW CONFIG" should only be written when the module is disabled (TIMERN_EN_EN = 0). Registers of type "W SYNC", "R SYNC" or "RW SYNC" should only be read or written when the module is enabled (TIMERN_EN_EN = 1). A typical setup sequence for a TIMER module is as follows:

1. With the TIMER disabled (TIMERN_EN_EN = 0), program any CONFIG registers required for the application.
2. Enable the TIMER by setting EN in TIMERN_EN to 1.
3. Program any non-CONFIG registers required for the application.
4. The TIMER is then ready for use.

19.3.2 Counter Modes

The timer consists of a counter that can be configured to the following modes, using the MODE field in `TIMERn_CFG`:

- Up-count: Counter counts up until it reaches the value in `TIMERn_TOP`, where it is reset to 0 before counting up again.
- Down-count: The counter starts at the value in `TIMERn_TOP` and counts down. When it reaches 0, it is reloaded with the value in `TIMERn_TOP`.
- Up/Down-count: The counter starts at 0 and counts up. When it reaches the value in `TIMERn_TOP`, it counts down until it reaches 0 and starts counting up again.
- Quadrature Decoder: Two input channels where one determines the count direction, while the other pin triggers a clock event.

In addition to the TIMER modes listed above, the TIMER also supports a 2x count mode. In this mode the counter increments/decrements by 2 on each clock edge. The 2x count mode can be used to double the PWM frequency when the compare/capture channel is put into PWM mode. The 2x count mode is enabled by setting the X2CNT bitfield in the `TIMERn_CTRL` register.

The counter value can be read or written by software any time the module is enabled by accessing the CNT field in `TIMERn_CNT`.

19.3.2.1 Events

The main counter can generate overflow and underflow events during operation.

Overflow (`TIMERn_IF_OF`) is set when the counter value shifts from `TIMERn_TOP` to the next value when counting up. In up-count mode and quadrature decoder mode the next value is 0. In up/down-count mode, the next value is `TIMERn_TOP-1`.

Underflow (`TIMERn_IF_UF`) is set when the counter value shifts from 0 to the next value when counting down. In down-count mode and quadrature decoder mode, the next value is `TIMERn_TOP`. In up/down-count mode the next value is 1.

An update event occurs on overflow in up-count mode and on underflow in down-count or up/down count mode. Additionally, an update event also occurs on overflow and underflow in quadrature decoder. This event is used to time updates of buffered values.

19.3.2.2 Operation

Figure 19.2 **TIMER Hardware Timer/Counter Control** on page 509 shows the hardware timer/counter control. Software can start or stop the counter by setting the START or STOP bits in `TIMERn_CMD`. The counter value (CNT in `TIMERn_CNT`) can always be written by software to any 16/32-bit value.

It is also possible to control the counter through either an external pin or PRS input. This is done through the input logic for the compare/capture Channel 0. The timer/counter allows individual actions (start, stop, reload) to be taken for rising and falling input edges. This is configured in the `RISEA` and `FALLA` fields in `TIMERn_CTRL`. The reload value is 0 in up-count and up/down-count mode and TOP in down-count mode.

The `RUNNING` bit in `TIMERn_STATUS` indicates if the timer is running or not. If the `SYNC` bit in `TIMERn_CFG` is set, the timer is started/stopped/reloaded (external pin or PRS) when any of the other timers are started/stopped/reloaded.

The `DIR` bit in `TIMERn_STATUS` indicates the counting direction of the timer at any given time. The counter value can be read or written by software through the `CNT` field in `TIMERn_CNT`. In Up/Down-Count mode the count direction will be set to up if the `CNT` value is written by software.

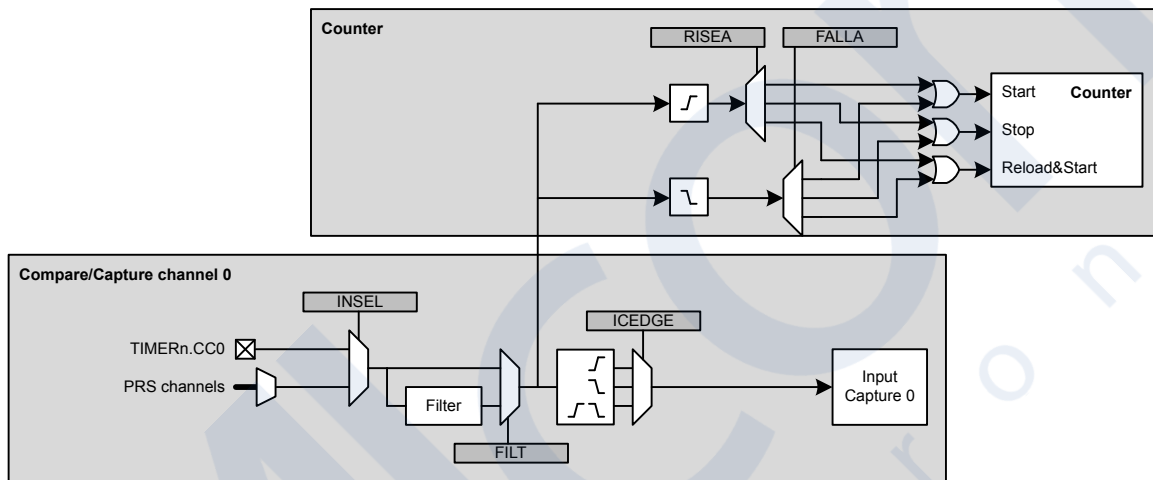

Figure 19.2. TIMER Hardware Timer/Counter Control

19.3.2.3 Clock Source

The counter can be clocked from several sources, which are all synchronized with the incoming peripheral clock for the timer. See Figure 19.3 **TIMER Clock Selection** on page 509.

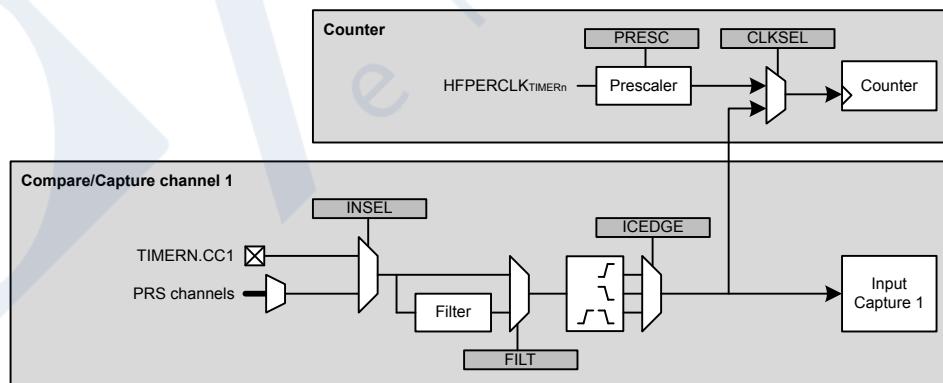

Figure 19.3. TIMER Clock Selection

19.3.2.4 Peripheral Clock

The peripheral clock for the timer ($\text{HFPERCLK}_{\text{TIMER}_n}$) clocks the logic for the timer block, even when it is not the selected clock source.

All TIMER instances in this device family use EM01GRPACLK selected in $\text{CMU_EM01GRPACLKCTRL_CLKSEL}$ as their peripheral clock source ($\text{HFPERCLK}_{\text{TIMER}_n}$).

The peripheral clock to each timer can be used as a source with a configurable 10-bit prescaler. The PRESC bitfield in TIMER_n_CFG sets the prescaler value, and the incoming peripheral clock will be divided by a factor of $(\text{PRESC}+1)$. However, if 2x count mode is enabled and the compare/capture channels are configured for PWM mode, the CC output is updated on both clock edges, so prescaling the peripheral clock will produce an incorrect result. The internal prescale counter is stopped and reset when the timer is stopped.

19.3.2.5 Compare/Capture Channel 1 Input

The timer can also be clocked by positive and/or negative edges on the compare/capture channel 1 input. This input can either come from the TIM_n_CC1 pin or one of the PRS channels. The input signal must not have a higher frequency than $f_{\text{HFPERCLK_TIMER}_n}/3$ when running from a pin input or a PRS input with FILT enabled in $\text{TIMER}_n_CCx_CFG$. When running from PRS without FILT , the frequency can be as high as $f_{\text{HFPERCLK_TIMER}_n}$. Note that when clocking the timer from the same pulse that triggers a start (through RISEA/FALLA in TIMER_n_CTRL), the starting pulse will not update the counter value.

19.3.2.6 Underflow/Overflow From Neighboring Timer

All timers are linked together (see [Figure 19.4 TIMER Connections on page 510](#)), allowing timers to count on overflow/underflow from the lower numbered neighbouring timers to form a larger timer. Note that all timers must be set to count the same direction and less significant timer(s) can only be set to count up or down.

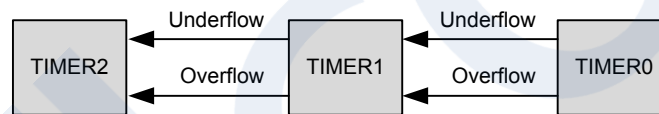

Figure 19.4. TIMER Connections

19.3.2.7 One-Shot Mode

By default, the counter counts continuously until it is stopped. If the OSMEN bit is set in the TIMER_n_CFG register, however, the counter is disabled by hardware on the first *update event* (see [19.3.2.1 Events](#)). Note that when the counter is running with CC1 as clock source and OSMEN is set, a CC1 capture event will not take place on the *update event* (CC1 rising edge) that stops the timer.

19.3.2.8 Top Value Buffer

The `TIMERN_TOP` register can be altered either by writing it directly or by writing to the `TIMER_TOPB` (buffer) register. When writing to the buffer register the `TIMERN_TOPB` register will be written to `TIMERN_TOP` on the next *update event*. Buffering ensures that the TOP value is not set below the actual count value. The `TOPBV` flag in `TIMERN_STATUS` indicates whether the `TIMERN_TOPB` register contains data that has not yet been written to the `TIMERN_TOP` register (see [Figure 19.5 TIMER TOP Value Update Functionality](#) on page 511).

Note: When writing to `TIMERN_TOP` register directly, the `TIMERN_TOPB` register value will be invalidated and the `TOPBV` flag will be cleared. This prevents `TIMERN_TOP` register from being immediately updated by an existing valid `TIMERN_TOPB` value during the next *update event*.

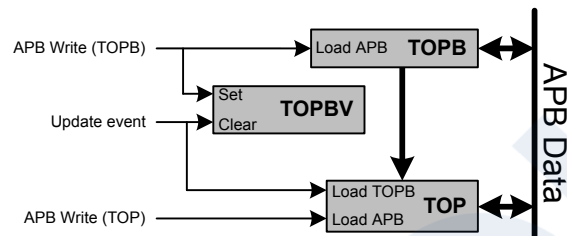

Figure 19.5. TIMER TOP Value Update Functionality

19.3.2.9 Quadrature Decoder

Quadrature decoding mode is used to track motion and determine both rotation direction and position. The quadrature decoder uses two input channels that are 90 degrees out of phase (see [Figure 19.6 TIMER Quadrature Encoded Inputs](#) on page 512).

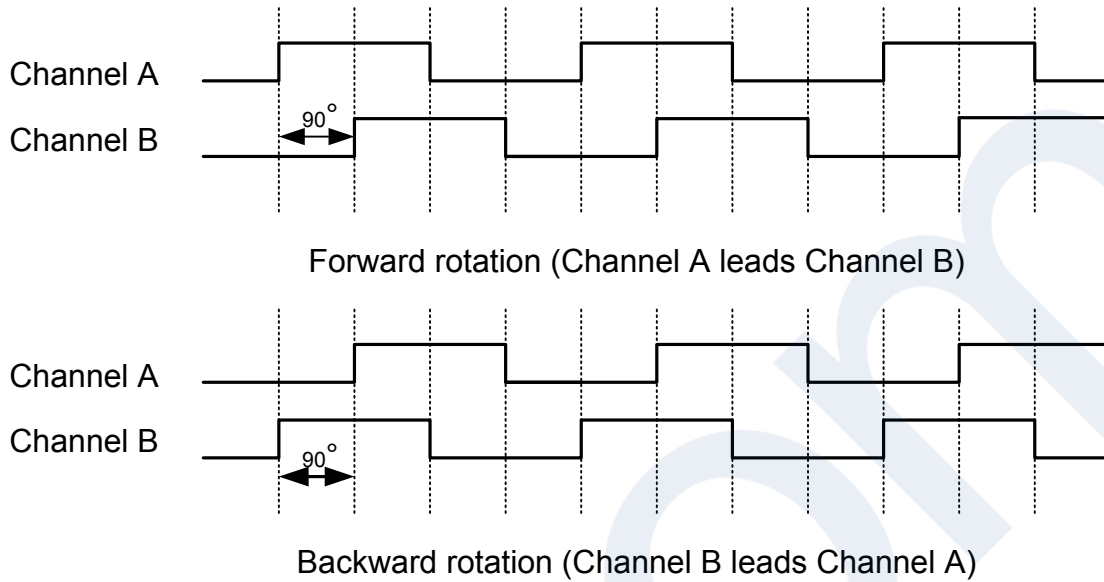

Figure 19.6. TIMER Quadrature Encoded Inputs

In the timer these inputs are tapped from the compare/capture channel 0 (Channel A) and 1 (Channel B) inputs before edge detection. The timer/counter then increments or decrements the counter, based on the phase relation between the two inputs. The DIRCHG flag in TIMERN_IF is set if the count direction changes in quadrature decoder mode. The quadrature decoder supports two channels, but if a third channel (Z-terminal) is available, this can be connected to an external interrupt and trigger a counter reset from the interrupt service routine. By connecting a periodic signal from another timer as input capture on compare/capture Channel 2, it is also possible to calculate speed and acceleration.

Note: In quadrature decoder mode, overflow and underflow triggers an *update event*.

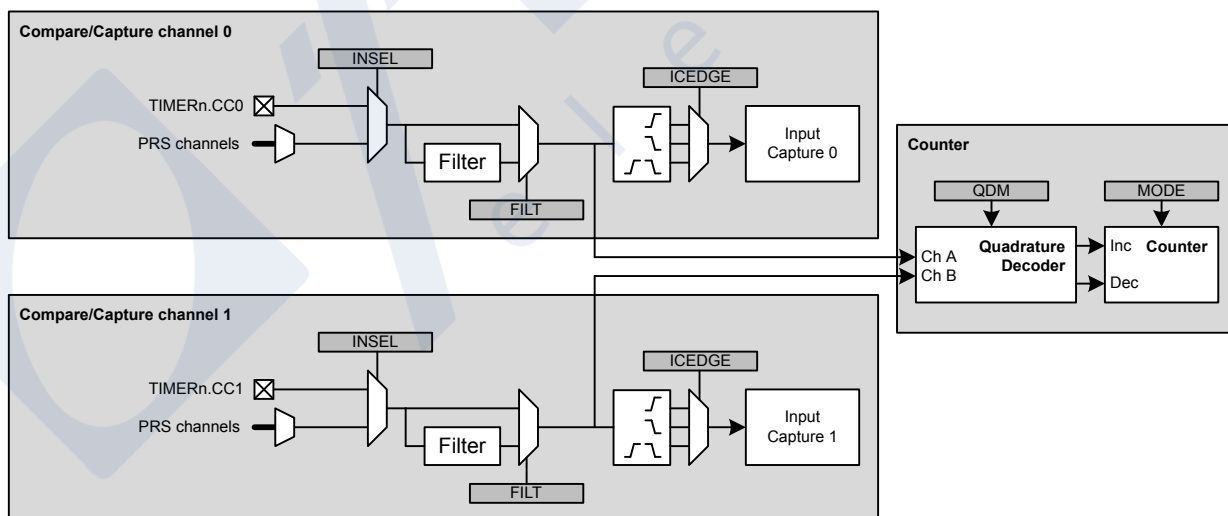

Figure 19.7. TIMER Quadrature Decoder Configuration

The quadrature decoder can be set in either X2 or X4 mode, which is configured in the QDM bit in TIMERN_CFG. See [Figure 19.7 TIMER Quadrature Decoder Configuration on page 512](#)

19.3.2.10 X2 Decoding Mode

In X2 Decoding mode, the counter increments or decrements on every edge of Channel A, see [Table 19.1 TIMER Counter Response in X2 Decoding Mode on page 513](#) and [Figure 19.8 TIMER X2 Decoding Mode on page 513](#).

Table 19.1. TIMER Counter Response in X2 Decoding Mode

Channel B	Channel A	
	Rising	Falling
0	Increment	Decrement
1	Decrement	Increment

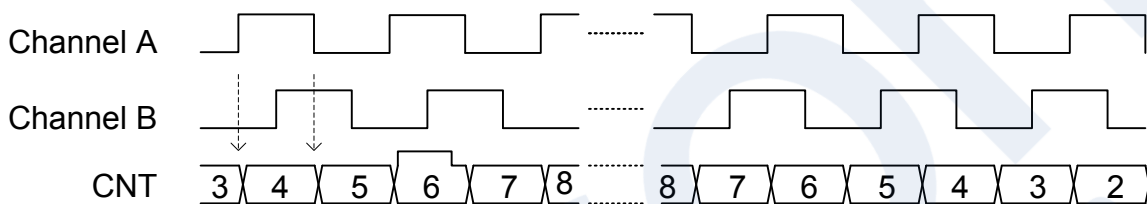

Figure 19.8. TIMER X2 Decoding Mode

19.3.2.11 X4 Decoding Mode

In X4 Decoding mode, the counter increments or decrements on every edge of Channel A and Channel B, see [Figure 19.9 TIMER X4 Decoding Mode on page 513](#) and [Table 19.2 TIMER Counter Response in X4 Decoding Mode on page 513](#).

Table 19.2. TIMER Counter Response in X4 Decoding Mode

Opposite Channel	Channel A		Channel B	
	Rising	Falling	Rising	Falling
Channel A = 0			Decrement	Increment
Channel A = 1			Increment	Decrement
Channel B = 0	Increment	Decrement		
Channel B = 1	Decrement	Increment		

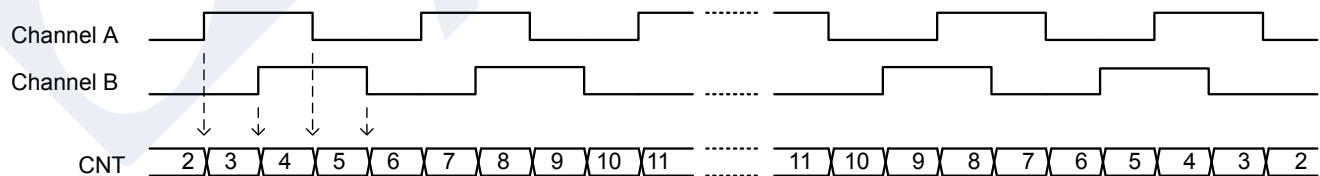

Figure 19.9. TIMER X4 Decoding Mode

19.3.2.12 Rotational Position

To calculate a position [Figure 19.10 TIMER Rotational Position Equation on page 514](#) can be used.

$$\text{pos}^\circ = (\text{CNT}/X \times N) \times 360^\circ$$

Figure 19.10. TIMER Rotational Position Equation

where X = Encoding type and N = Number of pulses per revolution.

19.3.3 Compare/Capture Channels

The timer contains compare/capture channels, which can be independently configured in the following modes:

1. Input Capture
2. Output Compare
3. PWM

19.3.3.1 Input Pin Logic

Each compare/capture channel can be configured as an input source for the Capture Unit or as external clock source for the timer (see [Figure 19.11 TIMER Input Pin Logic on page 514](#)). Compare/capture channels 0 and 1 are the inputs for the quadrature decoder. The input channel can be filtered before it is used, which requires the input to remain stable for up to 5 cycles in a row before the input is propagated to the output.

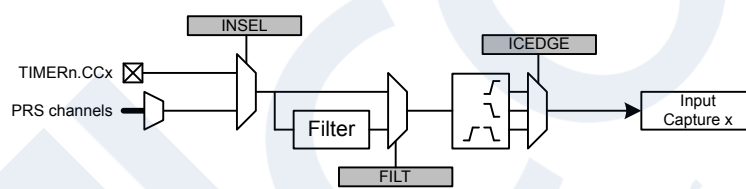

Figure 19.11. TIMER Input Pin Logic

The capture input to the timer may be selected from the dedicated CCx signal for the channel, or a PRS signal. INSEL in `TIMERn_CCx_CFG` determines the input to the channel. When set to PIN, the selected CCx pin will be used. When INSEL is set to PRSSYNC, a synchronous PRS channel is selected as the source. The synchronous PRS channel is determined by the SPRSSEL field in the `PRS_TIMERn_CCx` register. Setting INSEL to PRSASYNCLEVEL or PRSASYNCPULSE selects an asynchronous PRS channel as the source. The asynchronous PRS channel is determined by the PRSSEL field in the `PRS_TIMERn_CCx` register.

The PIN and PRSASYNCLEVEL selections are qualified by a 2-clock input sampler. To recognize and capture the incoming signal, it must be at the new level for at least 2 $\text{HPPERCLK}_{\text{TIMERn}}$ clock cycles. An additional 5 $\text{HPPERCLK}_{\text{TIMERn}}$ cycles of filtering can be applied to the signal by enabling the FILT bit in `TIMERn_CCx_CFG`.

The PRSASYNCPULSE selection can be used to capture higher-speed pulses on an asynchronous PRS input. The input logic for this selection does not qualify the level of the incoming signal. Instead, it will recognize positive or negative edges directly. While the pulse time can be shorter than 1 $\text{HPPERCLK}_{\text{TIMERn}}$, this mode requires at least 3 $\text{HPPERCLK}_{\text{TIMERn}}$ clocks between adjacent events. The FILT option is not used in this mode.

Synchronous PRS signals are inherently synchronized to the module clock, and the 2-clock input sampler is not used. However, it is possible to use FILT to enable the 5 $\text{HPPERCLK}_{\text{TIMERn}}$ filter when using the PRSSYNC option.

19.3.3.2 Compare/Capture Registers

The compare/capture channel registers are prefixed with `TIMERn_CCx_`, where the x stands for the channel number. Since the compare/capture channels serve three functions (input capture, compare, PWM), different registers are used, depending on the mode the channel is set in.

19.3.3.3 Input Capture

In input capture, the counter value (TIMERN_CNT) can be captured in the Input Capture Register (TIMERN_CCx_ICF) (see [Figure 19.12 TIMER Input Capture on page 515](#)). The CCPOL bits in TIMERN_STATUS indicate the polarity of the edge that triggered the capture in TIMERN_CCx_ICF.

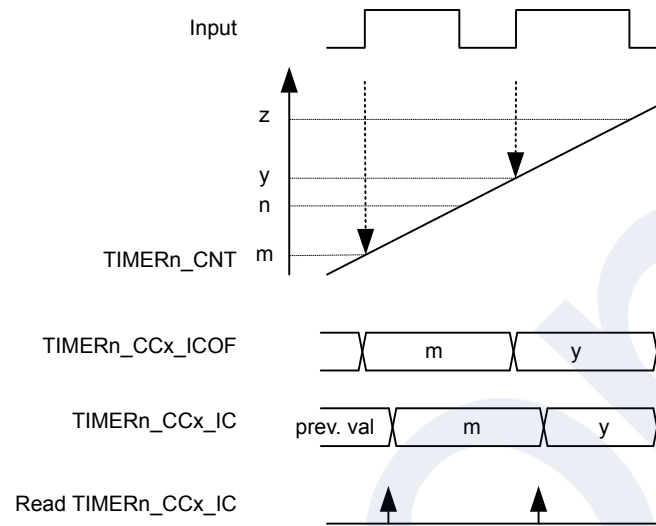

Figure 19.12. TIMER Input Capture

Input captures are buffered into a 2-entry FIFO, allowing 2 subsequent capture events to take place before a read-out is required. Reading TIMERN_CCx_ICF from software or DMA pops the oldest unread value from the FIFO. If TIMERN_CCx_ICF is read when the FIFO is empty (ICFEMPTY in TIMERN_STATUS = 1), the FIFO underflow flag for the channel (ICFUF in TIMERN_IF) will be set. The Input Capture Overflow Register (TIMERN_CCx_ICOF) always contains the newest value in the FIFO. If a new capture is triggered while the FIFO is full, the value in TIMERN_CCx_ICOF will be over-written with the latest value and the FIFO overflow flag (ICFOF in TIMERN_IF) for the channel will be set. Reading TIMERN_CCx_ICOF does not alter the FIFO contents.

The input capture FIFO also has a programmable watermark level that can be configured to generate interrupts or trigger DMA requests when a certain number of empty spots are left in the FIFO. The ICFWLFULL flag in TIMERN_IF will be set when the number of empty spots left in the FIFO is less than or equal to the watermark level programmed in TIMERN_CCx_CFG_ICFWL. At a minimum, a TIMER module will have two FIFO entries, but may have more on future devices.

The ICFEMPTY flag in TIMERN_STATUS indicates when the capture buffer is empty. When this bit reads '0', there is a valid unread capture in the FIFO.

Note: In input capture mode, the timer will only trigger interrupts when it is running.

19.3.3.4 Period/Pulse-Width Capture

Period and/or pulse-width capture can only be possible with Channel 0 (CC0), because this is the only channel that can start and stop the timer. This can be done by setting the RISEA field in TIMERN_CTRL to Clear&Start, and selecting the desired input from either external pin or PRS, see [Figure 19.13 TIMER Period and/or Pulse Width Capture on page 516](#). For period capture, the compare/capture channel should then be set to input capture on a rising edge of the same input signal. To capture the width of a high pulse, the compare/capture channel should be set to capture on a falling edge of the input signal. To measure the low pulse-width of a signal, opposite polarities should be chosen.

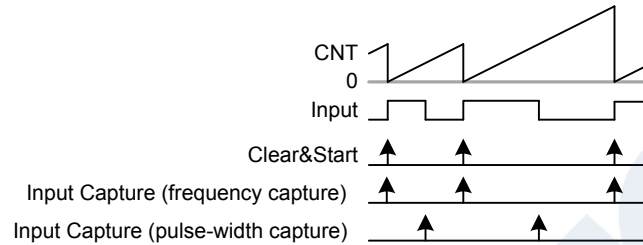

Figure 19.13. TIMER Period and/or Pulse Width Capture

19.3.3.5 Compare

Each compare/capture channel contains a comparator which outputs a compare match if the contents of `TIMERn_CCx_OC` matches the counter value, see [Figure 19.14 TIMER Block Diagram Showing Comparison Functionality on page 517](#). In compare mode, each compare channel can be configured to either set, clear or toggle the output on an event (compare match, overflow or underflow). The output from each channel is represented as an alternative function on the port it is connected to, which needs to be enabled for the CC outputs to propagate to the pins.

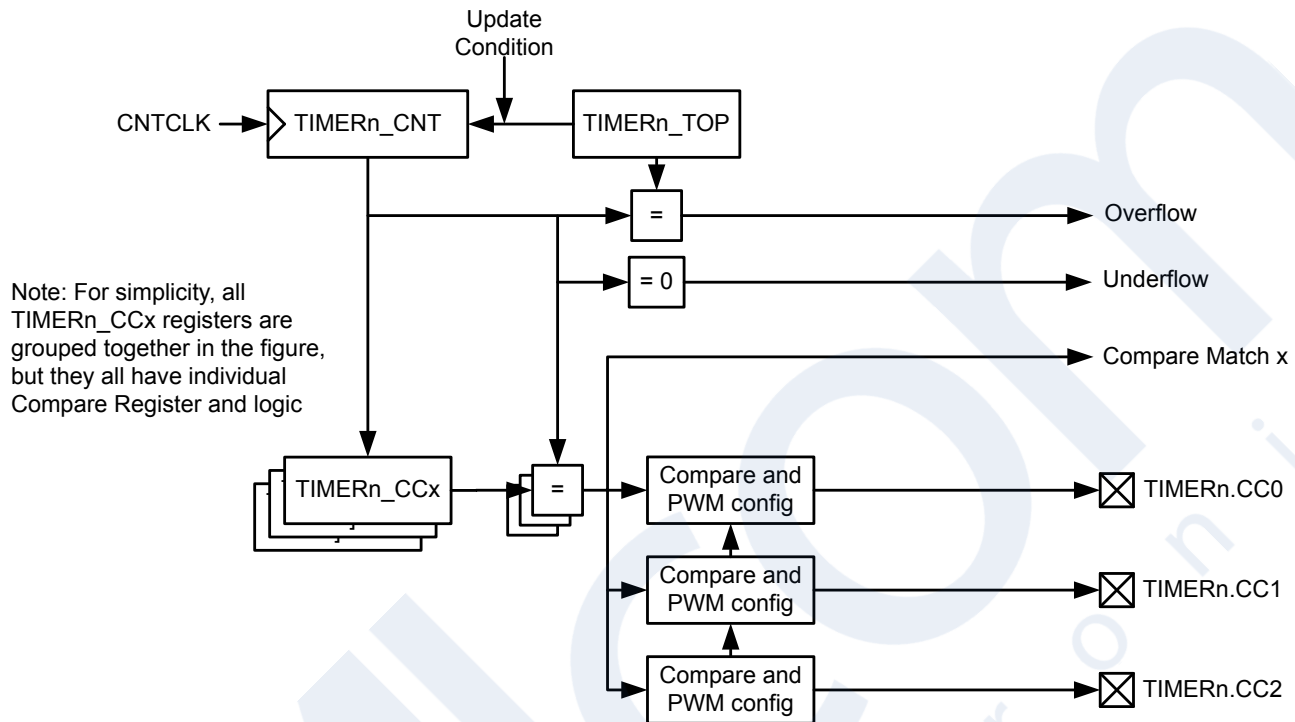

Figure 19.14. TIMER Block Diagram Showing Comparison Functionality

The compare output is delayed by one cycle to allow for full 0% to 100% PWM generation. If occurring in the same cycle, match action will have priority over overflow or underflow action.

The input selected (through `PRSEL` in `PRS_CONSUMER_TIMERn_CCx`, `INSEL` and `FILT` in `TIMERn_CCx_CFG`) for the CC channel will also be sampled on compare match and the result is found in the `CCPOL` bits in `TIMERn_STATUS`. It is also possible to configure the `CCPOL` to always track the inputs by setting `ATI` in `TIMERn_CFG`.

Note: When using synchronous PRS sources, it is recommended to configure the PRS consumer registers prior to selecting PRS triggering to avoid any false triggers.

The `COIST` bit in `TIMERn_CCx_CFG` is the initial state of the compare/PWM output. The `COIST` bit can also be used as an initial value to the compare outputs on a reload-start when `RSSCOIST` is set in `TIMERn_CFG`. Also the resulting output can be inverted by setting `OUTINV` in `TIMERn_CCx_CTRL`. It is recommended to turn off the CC channel before configuring the output state to avoid any unwanted pulses on the output. The CC channel can be turned off by setting `MODE` to `OFF` in `TIMERn_CCx_CFG`. The following figure shows the output logic for the TIMER module.

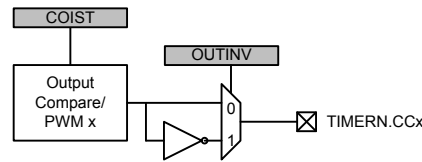

Figure 19.15. TIMER Output Logic

19.3.3.6 Compare Mode Registers

When running in output compare or PWM mode, the value in `TIMERN_CCx_OC` will be compared against the count value. In Compare mode the output can be configured to toggle, clear or set on compare match, overflow, and underflow through the `CMOA`, `COFOA` and `CUFOA` fields in `TIMERN_CCx_CTRL`. `TIMERN_CCx_OC` can be accessed directly or through the buffer register `TIMERN_CCx_OCB`, see [Figure 19.16 TIMER Output Compare/PWM Buffer Functionality Detail on page 518](#). When writing to the buffer register, the value in `TIMERN_CCx_OCB` will be written to `TIMERN_CCx_OC` on the next *update event*. This functionality ensures glitch free PWM outputs. The `OCBV` flag in `TIMERN_STATUS` indicates whether the `TIMERN_CCx_OCB` register contains data that has not yet been written to the `TIMERN_CCx_OC` register. Note that when writing 0 to `TIMERN_CCx_OCB` in up-down count mode the OC value is updated when the timer counts from 0 to 1. Thus, the compare match for the next period will not happen until the timer reaches 0 again on the way down.

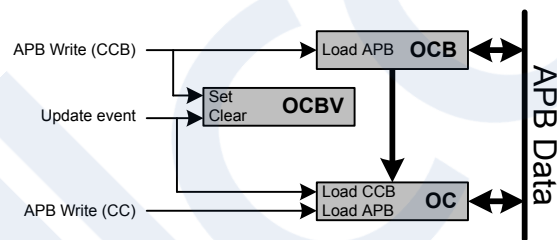

Figure 19.16. TIMER Output Compare/PWM Buffer Functionality Detail

19.3.3.7 Frequency Generation (FRG)

Frequency generation (see [Figure 19.17 TIMER Up-count Frequency Generation on page 519](#)) can be achieved in compare mode by:

- Setting the counter in up-count mode
- Enabling buffering of the TOP value.
- Setting the CC channels overflow action to toggle

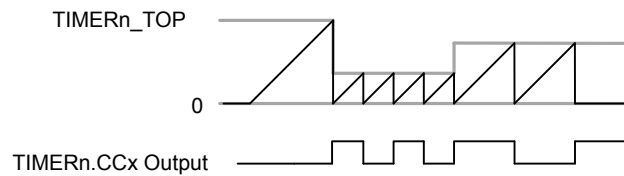

Figure 19.17. TIMER Up-count Frequency Generation

The output frequency is given by [Figure 19.18 TIMER Up-count Frequency Generation Equation on page 519](#)

$$f_{FRG} = f_{HFPERCLK_TIMERn} / [2 \times (PRESC + 1) \times (TOP + 1)]$$

Figure 19.18. TIMER Up-count Frequency Generation Equation

The figure below provides cycle accurate timing and event generation information for frequency generation.

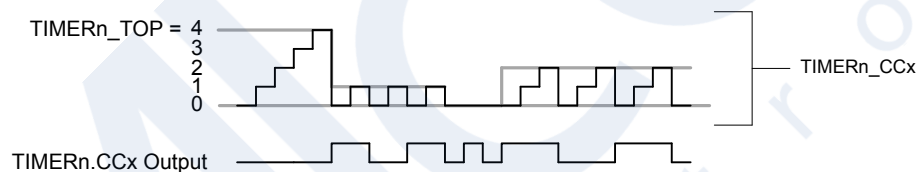

Figure 19.19. TIMER Up-count Frequency Generation Detail

19.3.3.8 Pulse-Width Modulation (PWM)

In PWM mode, `TIMERn_CCx_OC` is buffered to avoid glitches in the output. The settings in the Compare Output Action configuration bits are ignored in PWM mode and PWM generation is only supported for up-count and up/down-count mode.

19.3.3.9 Up-count (Single-slope) PWM

If the counter is set to up-count and the compare/capture channel is put in PWM mode, single slope PWM output will be generated (see [Figure 19.20 TIMER Up-count PWM Generation on page 520](#)). In up-count mode the PWM period is TOP+1 cycles and the PWM output will be high for a number of cycles equal to TIMERn_CCx_OC. This means that a constant high output is achieved by setting TIMERn_CCx_OC to TOP+1 or higher. The PWM resolution (in bits) is then given by [Figure 19.21 TIMER Up-count PWM Resolution Equation on page 520](#).

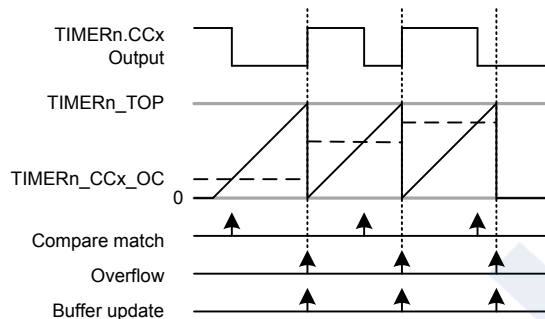

Figure 19.20. TIMER Up-count PWM Generation

$$R_{PWM_{up}} = \log(TOP+1)/\log(2)$$

Figure 19.21. TIMER Up-count PWM Resolution Equation

The PWM frequency is given by [Figure 19.22 TIMER Up-count PWM Frequency Equation on page 520](#):

$$f_{PWM_{up}} = f_{HCLK_TIMERn} / [(PRESC + 1) \times (TOP + 1)]$$

Figure 19.22. TIMER Up-count PWM Frequency Equation

The high duty cycle is given by [Figure 19.23 TIMER Up-count Duty Cycle Equation on page 520](#)

$$DS_{up} = OCx/(TOP+1)$$

Figure 19.23. TIMER Up-count Duty Cycle Equation

The figure below provides cycle accurate timing and event generation information for up-count mode.

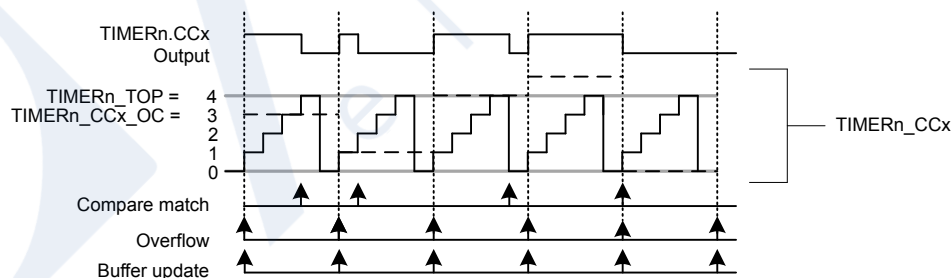

Figure 19.24. TIMER Up-count PWM Generation Detail

19.3.3.10 2x Count Mode (Up-count)

When the timer is set in 2x mode, the TIMER will count up by two for every (prescaled) clock. This will in effect make any odd Top value be rounded down to the closest even number. Similarly, any odd OC value will generate a match on the closest lower even value as shown in [Figure 19.25 TIMER CC Out in 2x Mode on page 521](#)

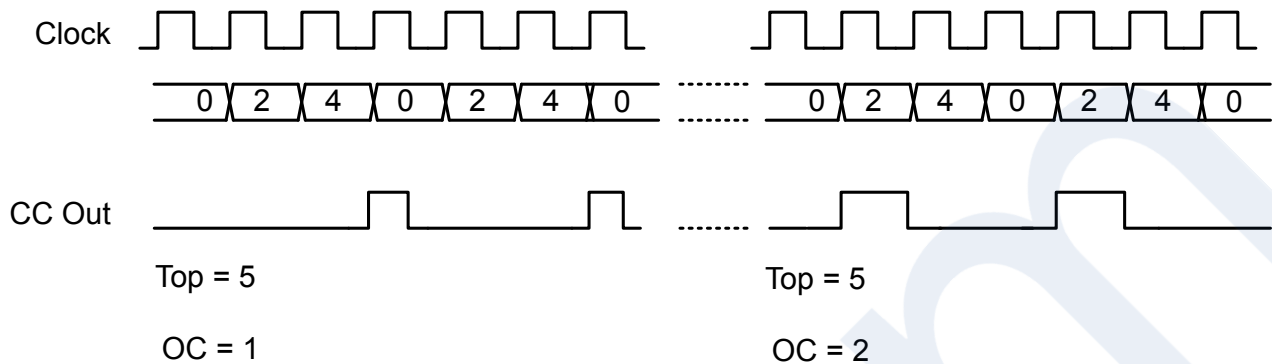

Figure 19.25. TIMER CC Out in 2x Mode

The PWM resolution is given by [Figure 19.26 TIMER 2x PWM Resolution Equation on page 521](#).

$$R_{\text{PWM}_{2\text{xmode}}} = \log(\text{TOP}/2+1)/\log(2)$$

Figure 19.26. TIMER 2x PWM Resolution Equation

The PWM frequency is given by [Figure 19.27 TIMER 2x Mode PWM Frequency Equation \(Up-count\) on page 521](#):

$$f_{\text{PWM}_{2\text{xmode}}} = f_{\text{HPPERCLK_TIMERn}} / [(\text{PRESC} + 1) \times (\text{floor}(\text{TOP}/2)+1)]$$

Figure 19.27. TIMER 2x Mode PWM Frequency Equation (Up-count)

The high duty cycle is given by [Figure 19.28 TIMER 2x Mode Duty Cycle Equation on page 521](#)

$$DS_{2\text{xmode}} = \text{OCx} / ((\text{floor}(\text{TOP}/2)+1)*2)$$

Figure 19.28. TIMER 2x Mode Duty Cycle Equation

19.3.3.11 Up/Down-count (Dual-slope) PWM

If the counter is set to up-down count and the compare/capture channel is put in PWM mode, dual slope PWM output will be generated by [Figure 19.29 TIMER Up/Down-count PWM Generation on page 522](#). The resolution (in bits) is given by [Figure 19.30 TIMER Up/Down-count PWM Resolution Equation on page 522](#).

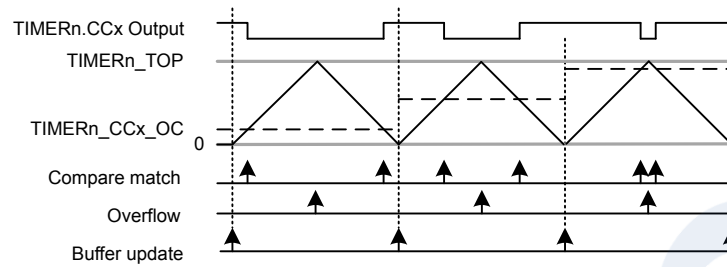

Figure 19.29. TIMER Up/Down-count PWM Generation

$$R_{PWM_{up/down}} = \log(TOP+1)/\log(2)$$

Figure 19.30. TIMER Up/Down-count PWM Resolution Equation

The PWM frequency is given by [Figure 19.31 TIMER Up/Down-count PWM Frequency Equation on page 522](#):

$$f_{PWM_{up/down}} = f_{HFPERCLK_TIMERn} / (2 \times (PRESC + 1) \times TOP)$$

Figure 19.31. TIMER Up/Down-count PWM Frequency Equation

The high duty cycle is given by [Figure 19.32 TIMER Up/Down-count Duty Cycle Equation on page 522](#)

$$DS_{up/down} = OCx/TOP$$

Figure 19.32. TIMER Up/Down-count Duty Cycle Equation

The figure below provides cycle accurate timing and event generation information for up-count mode.

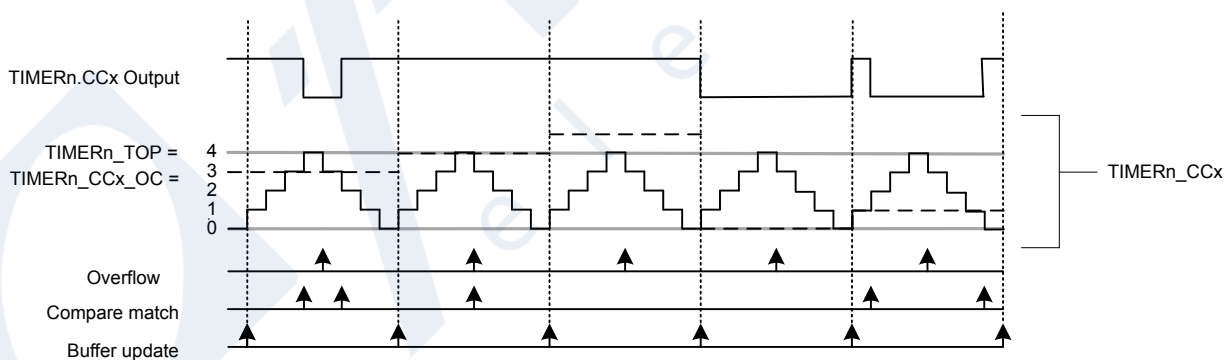

Figure 19.33. TIMER Up/Down-count PWM Generation

19.3.3.12 2x Count Mode (Up/Down-count)

When the timer is set in 2x mode, the TIMER will count up/down by two. This will in effect make any odd Top value be rounded down to the closest even number. Similarly, any odd OC value will generate a match on the closest lower even value as shown in [Figure 19.34 TIMER CC Out in 2x mode on page 523](#)

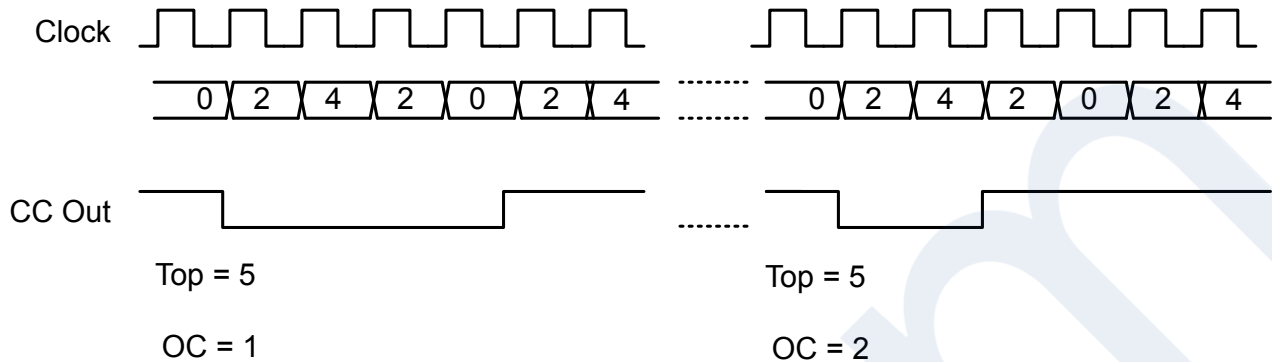

Figure 19.34. TIMER CC Out in 2x mode

[Figure 19.35 TIMER 2x PWM Resolution Equation on page 523.](#)

$$R_{PWM_{2xmode}} = \log(TOP/2+1)/\log(2)$$

Figure 19.35. TIMER 2x PWM Resolution Equation

The PWM frequency is given by [Figure 19.36 TIMER 2x Mode PWM Frequency Equation \(Up/Down-count\) on page 523:](#)

$$f_{PWM_{2xmode}} = f_{HFPERCLK_TIMERn} / (2 \times (PRESC + 1) \times (\text{floor}(TOP/2)))$$

Figure 19.36. TIMER 2x Mode PWM Frequency Equation (Up/Down-count)

The high duty cycle is given by two equations based on the OCx values. [Figure 19.37 TIMER 2x Mode Duty Cycle Equation for OCx = 1 or OCx = Even on page 523](#) and [Figure 19.38 TIMER 2x Mode Duty Cycle Equation for all Other OCx = Odd Values on page 523](#)

$$DS_{2xmode} = (OCx*2)/(\text{floor}(TOP/2)*4)$$

Figure 19.37. TIMER 2x Mode Duty Cycle Equation for OCx = 1 or OCx = Even

$$DS_{2xmode} = (OCx*2 - OCx)/(\text{floor}(TOP/2)*4)$$

Figure 19.38. TIMER 2x Mode Duty Cycle Equation for all Other OCx = Odd Values

19.3.3.13 Re-Timing PWM Outputs

PWM outputs are normally synchronous to the TIMER peripheral clock. However for radio applications, it can be desirable to synchronize PWM edges to radio clocks to reduce the interference with RF signalling.

Re-timing is enabled by setting the RETIMEEN bit in TIMERN_CFG to 1. When RETIMEEN is enabled, PWM X2CNT mode should not be enabled. Doing so may result in unpredictable PWM behavior.

Direct re-timing is supported at peripheral clock frequencies up to 50 MHz. For higher peripheral clock frequencies, set the RETIMESEL bit in TIMERN_CFG to 1. This allows PWM outputs to be re-timed at frequencies up to 80 MHz, but will introduce up to 1 HFPERCLK_{TIMERN} cycle of jitter between the PWM outputs.

19.3.3.14 Timer Configuration Lock

To prevent software errors from making changes to the timer configuration, a configuration lock is available. Writing any value but 0xCE80 to LOCKKEY in TIMERN_LOCK will lock writes to TIMERN_CTRL, TIMERN_CFG, TIMERN_CMD, TIMERN_TOP, TIMERN_TOPB, TIMERN_CNT, TIMERN_CCx_CTRL, TIMERN_CCx_CFG, TIMERN_CCx_OC, and TIMERN_CCx_OCB. To unlock the registers, write 0xCE80 to LOCKKEY in TIMERN_LOCK. The value of TIMERLOCKSTATUS in TIMERN_STATUS is 1 when the lock is active, and 0 when the registers are unlocked.

19.3.4 Dead-Time Insertion Unit

Some timer modules include a Dead-Time Insertion unit suitable for motor control applications. Refer to the device data sheet to check which timer instances have this feature. The example settings in this section are for TIMER0, but identical settings can be used for other timers with DTI as well. The Dead-Time Insertion Unit aims to make control of brushless DC (BLDC) motors safer and more efficient by introducing complementary PWM outputs with dead-time insertion and fault handling, see [Figure 19.39 TIMER Dead-Time Insertion Unit Overview on page 525](#).

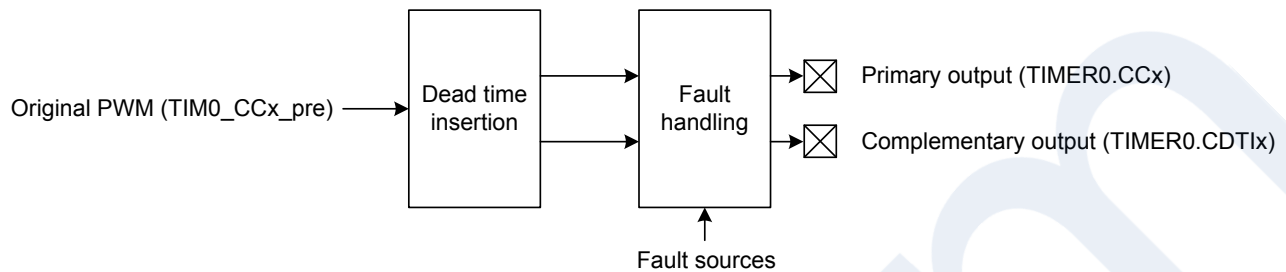

Figure 19.39. TIMER Dead-Time Insertion Unit Overview

When used for motor control, the PWM outputs TIM0_CC0, TIM0_CC1 and TIM0_CC2 are often connected to the high-side transistors of a triple half-bridge setup (UH, VH and WH), and the complementary outputs connected to the respective low-side transistors (UL, VL, WL shown in [Figure 19.40 TIMER Triple Half-Bridge on page 525](#)). Transistors used in such a bridge often do not open/close instantaneously, and using the exact complementary inputs for the high and low side of a half-bridge may result in situations where both gates are open. This can give unnecessary current-draw and short circuit the power supply. The DTI unit provides dead-time insertion to deal with this problem.

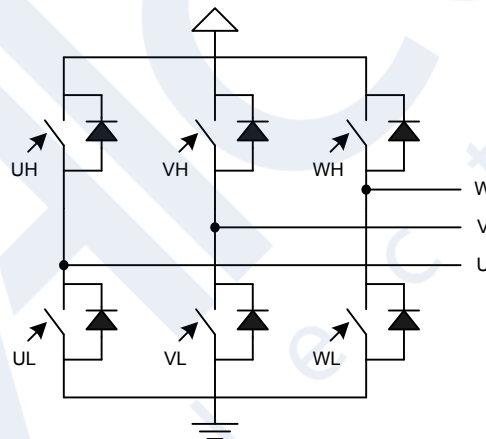

Figure 19.40. TIMER Triple Half-Bridge

For each of the 3 compare-match outputs of TIMER0, an additional complementary output is provided by the DTI unit. These outputs, named TIM0_CDTI0, TIM0_CDTI1 and TIM0_CDTI2 are provided to make control of e.g. 3-channel BLDC or permanent magnet AC (PMAC) motors possible using only a single timer, see [Figure 19.41 TIMER Overview of Dead-Time Insertion Block for a Single PWM Channel on page 526](#).

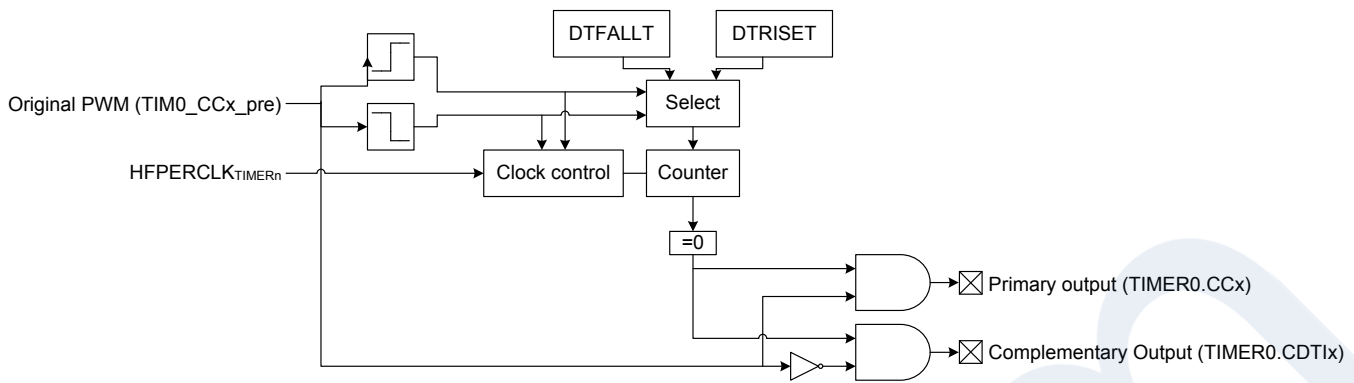

Figure 19.41. TIMER Overview of Dead-Time Insertion Block for a Single PWM Channel

The DTI unit is enabled by setting DTEN in TIMER0_DTCFG. In addition to providing the complementary outputs, the DTI unit then also overrides the compare match outputs from the timer.

The DTI unit gives the rising edges of the PWM outputs and the rising edges of the complementary PWM outputs a configurable time delay. By doing this, the DTI unit introduces a dead-time where both the primary and complementary outputs in a pair are inactive as seen in [Figure 19.42 TIMER Polarity of Both Signals are Set as Active-High on page 526](#).

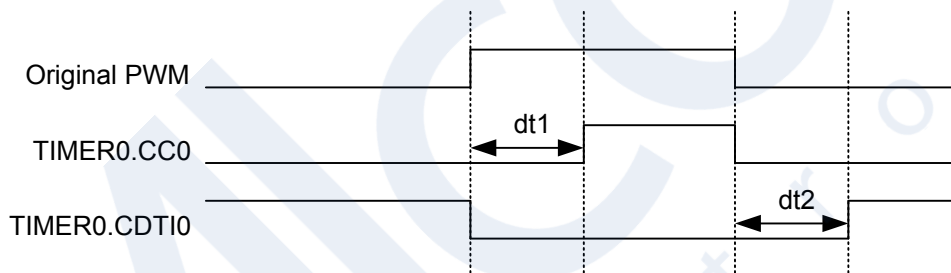

Figure 19.42. TIMER Polarity of Both Signals are Set as Active-High

Dead-time is specified individually for the rising and falling edge of the original PWM. These values are shared across all the three PWM channels of the DTI unit. A single prescaler value is provided for the DTI unit, meaning that both the rising and falling edge dead-times share prescaler value. The prescaler divides the HFPERCLK_{TIMER0} by a configurable factor between 1 and 1024, which is set in the DTPRESC field in TIMER0_DTTIMECFG. The rising and falling edge dead-times are configured in DTRISSET and DTFALLT in TIMER0_DTTIMECFG to any number between 1-64 HFPERCLK_{TIMER0} cycles.

The DTAR and DTFATS bits in TIMER0_DTCFG control the DTI output behavior when the timer stops. By default the DTI block stops when the timer is stopped. Setting the DTAR bit will cause the DTI output on channel 0 to continue when the timer is stopped. DTAR effects only channel 0. See [19.3.4.2 PRS Channel as a Source](#) for an example of when this can be used. While in this mode the undivided HFPERCLK_{TIMER0} (DTPRESC=0) is always used regardless of the programmed DTPRESC value in TIMER0_DTTIMECFG. This means that rise and fall dead times are calculated assuming DTPRESC = 0.

When the timer stops, DTI outputs are frozen by default, preserving their last state. To allow the outputs to go to a safe state, program the DTFA field of the TIMER0_DTCFG register to the safe values and set the DTFATS bitfield in the TIMER0_DTCFG register. Note that when DTAR is also set, DTAR has priority over DTFATS for DTI channel 0 output.

The following table shows the DTI output when the timer is halted.

Table 19.3. DTI Output When Timer Halted

DTAR	DTFATS	State
0	0	frozen
0	1	safe
1	0	running
1	1	running

19.3.4.1 Output Polarity

The value of the primary and complementary outputs in a pair will never be set active at the same time by the DTI unit. The polarity of the outputs can be changed if this is required by the application. The active values of the primary and complementary outputs are set by the DTIPOL and DTCINV bits in the `TIMER0_DTCTRL` register. The DTIPOL bit of this register specifies the base polarity. If DTIPOL = 0, then the outputs are active-high, and if DTIPOL = 1 they are active-low. The relative phase of the primary and complementary outputs is not changed by DTIPOL, as the polarity of both outputs is changed, see [Figure 19.43 TIMER Output Polarities on page 527](#).

In some applications, it may be required that the primary outputs are active-high, while the complementary outputs are active-low. This can be accomplished by manipulating the DTCINV bit of the `TIMER0_DTCTRL` register, which inverts the polarity of the complementary outputs relative to the primary outputs. As an example, DTIPOL = 0 and DTCINV = 0 results in outputs with opposite phase and active-high states. Similarly, DTIPOL = 1 and DTCINV = 1 results in outputs with equal phase and the primary output will be active-high while the complementary will be active-low.

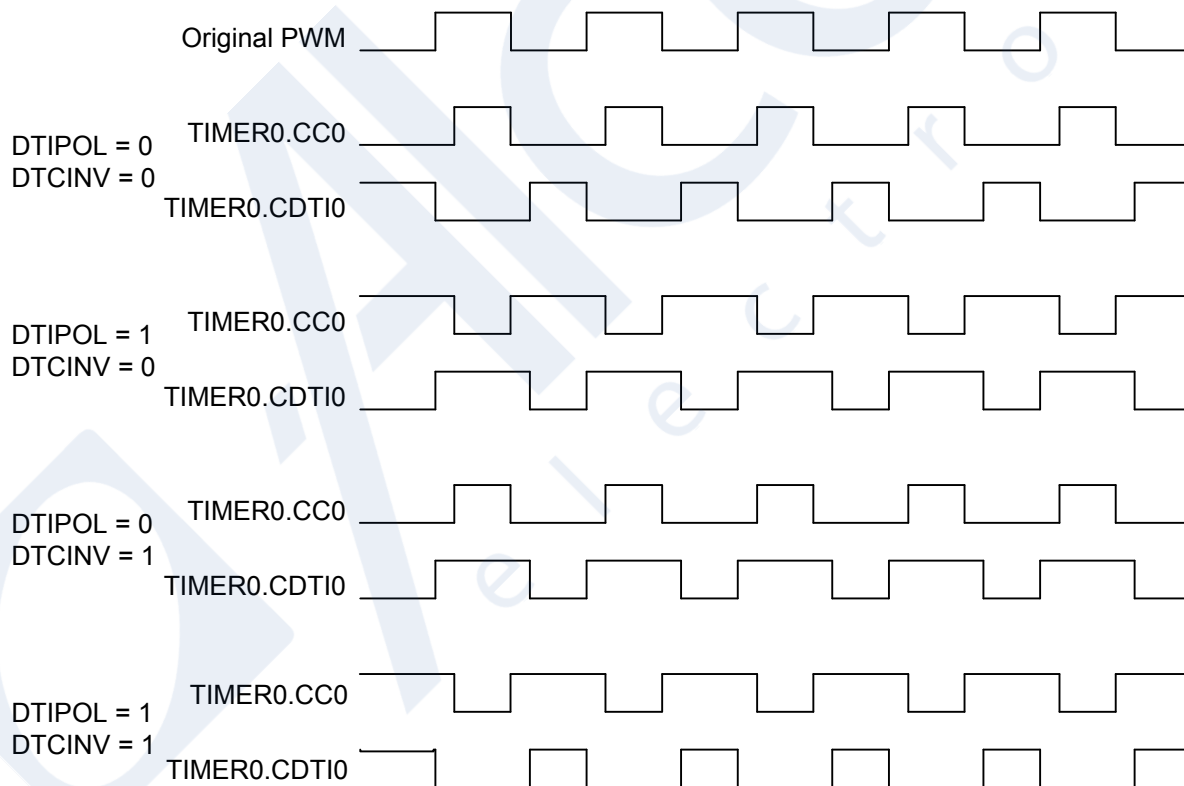

Figure 19.43. TIMER Output Polarities

Output generation on the individual DTI outputs can be disabled by configuring `TIMER0_DTOGEN`. When output generation on an output is disabled that output will go to and stay in its inactive state.

19.3.4.2 PRS Channel as a Source

A PRS channel can be used as input to the DTI module instead of the PWM output from the timer for DTI channel 0. Setting DTPRSN in `TIMER0_DTCFG` will override the source of the first DTI channel, driving `TIM0_CC0` and `TIM0_CDTI0`, with the value on the PRS channel. The rest of the DTI channels will continue to be driven by the PWM output from the timer. The input PRS channel is chosen within the PRS module with `PRSEL` in the `PRS_CONSUMER_TIMERn_DTI` register. Note that the timer must be running even when PRS is used as the DTI source. However, if it is required to keep the DTI channel 0 running even when the timer is stopped, set `DTAR` in `TIMER0_DTCFG`. When this bit is set, it uses `DTPRESC=0` regardless of the value programmed in `DTPRESC` in `TIMER0_DTTIMECFG`.

Note: When using synchronous PRS sources, it is recommended to configure the PRS consumer registers prior to selecting PRS triggering to avoid any false triggers.

The DTI prescaler, set by `DTPRESC` in `TIMER0_DTTIMECFG` determines the accuracy with which the DTI can insert dead-time into a PRS signal. The maximum dead-time error equals `DTIPRESC+1` clock cycles. With `DTIPRESC = 0`, the inserted dead-times are therefore accurate, but they may be inaccurate for larger prescaler settings.

19.3.4.3 Fault Handling

The fault handling system of the DTI unit allows the outputs of the DTI unit to be put in a well-defined state in case of a fault. This hardware fault handling system enables a fast reaction to faults, reducing the possibility of damage to the system.

The fault sources which trigger a fault in the DTI module are determined by the bitfields of `TIMER0_DTFCFG` register. Any combination of the available error sources can be selected:

- PRS source 1, determined by `PRSEL` in `PRS_CONSUMER_TIMERn_DTIFS1`
- PRS source 2, determined by `PRSEL` in `PRS_CONSUMER_TIMERn_DTIFS2`
- Debugger
- Core Lockup
- EM2 or EM3 Entry

One or two PRS channels can be used as an error source. When PRS source 1 is selected as an error source, `PRSEL` in `PRS_CONSUMER_TIMERn_DTIFS1` determines which PRS channel is used for this source. `PRSEL` in `PRS_CONSUMER_TIMERn_DTIFS2` determines which PRS channel is selected as PRS source 2. Note that for Core Lockup, the `LOCKUPRDIS` in `RMU_CTRL` must be set. Otherwise this will generate a full reset of the chip.

Note: When using synchronous PRS sources, it is recommended to configure the PRS consumer registers prior to selecting PRS triggering to avoid any false triggers.

19.3.4.4 Action on Fault

When a fault occurs, the bit representing the fault source is set in `TIMER0_DTFAULT` register, and the outputs from the DTI unit are set to a well-defined state. The following options are available, and can be enabled by configuring `DTFA` in `TIMER0_DTFCFG`:

- Set outputs to inactive level
- Clear outputs
- Tristate outputs

With the first option enabled, the output state in case of a fault depends on the polarity settings for the individual outputs. An output set to be active high will be set low if a fault is detected, while an output set to be active low will be driven high.

When a fault occurs, the fault source(s) can be read out from `TIMER0_DTFAULT` register.

Additionally a fault action can also be triggered when the timer stops if `DTFATS` in `TIMER0_DTCFG` is set. This allows the DTI output to go to safe state specified by `DTFA` in `TIMER0_DTFCFG` when the timer stops. When `DTAR` and `DTFATS` in `TIMER0_DTCFG` are both set, DTI channel 0 keeps running even when the timer stops. This is useful when DTI channel 0 has an input coming from PRS.

19.3.4.5 Exiting Fault State

When a fault is triggered by the PRS system, software intervention is required to re-enable the outputs of the DTI unit. This is done by manually clearing bits in the `TIMER0_DTFAULT` register. If the fault source as determined by checking `TIMER0_DTFAULT` is the debugger alone, the outputs can be automatically restarted when the debugger exits. To enable automatic restart set `DTDAS` in `TIMER0_DTCFG`. When an automatic restart occurs the `DTDBGF` bit in `TIMER0_DTFAULT` will be automatically cleared by hardware. If any other bits in the `TIMER0_DTFAULT` register are set when the hardware clears `DTDBGF` the DTI module will not exit the fault state.

19.3.4.6 DTI Configuration Lock

To prevent software errors from making changes to the DTI configuration, a configuration lock is available. Writing any value but 0xCE80 to LOCKKEY in TIMER0_DTLOCK locks writes to registers TIMER0_DTCFG, TIMER0_DTF CFG, TIMER0_DTCTRL, and TIMER0_DTTIMECFG. To unlock the registers, write 0xCE80 to LOCKKEY in TIMER0_DTLOCK. The value of DTILOCKSTATUS in TIMERN_STATUS is 1 when the lock is active, and 0 when the registers are unlocked.

19.3.5 Debug Mode

When the CPU is halted in debug mode, the timer can be configured to either continue to run or to be frozen. This is configured in DEBUGRUN in TIMERN_CFG.

19.3.6 Interrupts, DMA and PRS Output

The timer can generate several type of output events:

- Counter Underflow
- Counter Overflow
- Quadrature Decoder Direction Change
- Compare match or input capture (one per compare/capture channel)

Each of the events has its own interrupt flag. Also, there are interrupt flags for each compare/capture channel which are set on FIFO overflow or underflow in capture mode. FIFO overflow happens when a new capture over-writes an old unread capture in TIMERN_CCx_ICF. FIFO underflow happens when software reads TIMERN_CCx_ICF while the FIFO is empty.

If the interrupt flags are set and the corresponding interrupt enable bits in TIMERN_IEN are set high, the timer will send out an interrupt request. Each of the events may optionally trigger signals to PRS channels. The PRSCONF field in TIMERN_CCx_CFG determines how PRS events are generated. When PRSCONF is set to PULSE, and event will lead to a one HPPERCLK_{TIMERN} cycle high pulse on individual PRS outputs. Setting PRSCONF to LEVEL will make the PRS output follow the compare match output. Interrupts are cleared by setting the corresponding bit in the TIMERN_IFC register.

Each of the events will also set a DMA request when they occur. The different DMA requests are cleared when certain acknowledge conditions are met, see [Table 19.4 TIMER DMA Events on page 529](#). Events which clear the DMA requests do not clear interrupt flags. Software must still manually clear the interrupt flag if interrupts are in use.

If DMACLACTION is set in TIMERN_CFG, the DMA request is cleared when the triggered DMA channel is active, without having to access any timer registers. This is useful in cases where a timer event is used to trigger a DMA transfer in output compare or PWM mode that does not target the OC or OCB registers. DMACLACTION is not applicable in input capture mode.

Table 19.4. TIMER DMA Events

Event	Acknowledge/Clear
Underflow/Overflow	Read or write to TIMERN_CNT or TIMERN_TOPB
CC0 Input Capture - ICFWLFULL0 flag set	ICFEMPTY0 flag set (read FIFO via TIMERN_CC0_ICF)
CC1 Input Capture - ICFWLFULL1 flag set	ICFEMPTY1 flag set (read FIFO via TIMERN_CC1_ICF)
CC2 Input Capture - ICFWLFULL2 flag set	ICFEMPTY2 flag set (read FIFO via TIMERN_CC2_ICF)
CC3 Input Capture - ICFWLFULL3 flag set	ICFEMPTY3 flag set (read FIFO via TIMERN_CC3_ICF)
CC0 Output Compare / PWM - Match event	Write TIMERN_CC0_OC or TIMERN_CC0_OCB
CC1 Output Compare / PWM - Match event	Write TIMERN_CC1_OC or TIMERN_CC1_OCB
CC2 Output Compare / PWM - Match event	Write TIMERN_CC2_OC or TIMERN_CC2_OCB
CC3 Output Compare / PWM - Match event	Write TIMERN_CC3_OC or TIMERN_CC3_OCB

19.3.7 GPIO Input/Output

The TIMn_CCx inputs/outputs and TIMn_CDTIx outputs are accessible as alternate functions through GPIO. Each pin connection can be enabled/disabled separately using the GPIO module control registers. See the device data sheet for the available locations for each signal.

19.4 TIMER Register Map

The offset register address is relative to the registers base address.

Offset	Name	Type	Description
0x000	TIMER_IPVERSION	R	IP Version ID
0x004	TIMER_CFG	RW CONFIG	Configuration Register
0x008	TIMER_CTRL	RW SYNC	Control Register
0x00C	TIMER_CMD	W SYNC	Command Register
0x010	TIMER_STATUS	RH	Status Register
0x014	TIMER_IF	RWH INTFLAG	Interrupt Flag Register
0x018	TIMER_IEN	RW	Interrupt Enable Register
0x01C	TIMER_TOP	RWH SYNC	Counter Top Value Register
0x020	TIMER_TOPB	RW SYNC	Counter Top Value Buffer Register
0x024	TIMER_CNT	RWH SYNC	Counter Value Register
0x02C	TIMER_LOCK	W	TIMER Configuration Lock Register
0x030	TIMER_EN	RW ENABLE	Module En
0x060	TIMER_CCx_CFG	RW CONFIG	CC Channel Configuration Register
0x064	TIMER_CCx_CTRL	RW SYNC	CC Channel Control Register
0x068	TIMER_CCx_OC	RWH SYNC	OC Channel Value Register
0x070	TIMER_CCx_OCB	RW SYNC	OC Channel Value Buffer Register
0x074	TIMER_CCx_ICF	RH(r)	IC Channel Value Register
0x078	TIMER_CCx_ICOF	RH SYNC	IC Channel Value Overflow Register
0x0E0	TIMER_DTFCFG	RW CONFIG	DTI Configuration Register
0x0E4	TIMER_DTTIMECFG	RW CONFIG	DTI Time Configuration Register
0x0E8	TIMER_DTFCFG	RW CONFIG	DTI Fault Configuration Register
0x0EC	TIMER_DTCTRL	RW SYNC	DTI Control Register
0x0F0	TIMER DTOGEN	RW SYNC	DTI Output Generation Enable Register
0x0F4	TIMER_DTFAULT	RH	DTI Fault Register
0x0F8	TIMER_DTFAULTC	W SYNC	DTI Fault Clear Register
0x0FC	TIMER_DTLOCK	W	DTI Configuration Lock Register
0x1000	TIMER_IPVERSION_SET	R	IP Version ID
0x1004	TIMER_CFG_SET	RW CONFIG	Configuration Register
0x1008	TIMER_CTRL_SET	RW SYNC	Control Register
0x100C	TIMER_CMD_SET	W SYNC	Command Register
0x1010	TIMER_STATUS_SET	RH	Status Register
0x1014	TIMER_IF_SET	RWH INTFLAG	Interrupt Flag Register
0x1018	TIMER_IEN_SET	RW	Interrupt Enable Register
0x101C	TIMER_TOP_SET	RWH SYNC	Counter Top Value Register
0x1020	TIMER_TOPB_SET	RW SYNC	Counter Top Value Buffer Register

Offset	Name	Type	Description
0x1024	TIMER_CNT_SET	RWH SYNC	Counter Value Register
0x102C	TIMER_LOCK_SET	W	TIMER Configuration Lock Register
0x1030	TIMER_EN_SET	RW ENABLE	Module En
0x1060	TIMER_CCx_CFG_SET	RW CONFIG	CC Channel Configuration Register
0x1064	TIMER_CCx_CTRL_SET	RW SYNC	CC Channel Control Register
0x1068	TIMER_CCx_OC_SET	RWH SYNC	OC Channel Value Register
0x1070	TIMER_CCx_OCB_SET	RW SYNC	OC Channel Value Buffer Register
0x1074	TIMER_CCx_ICF_SET	RH(r)	IC Channel Value Register
0x1078	TIMER_CCx_ICOF_SET	RH SYNC	IC Channel Value Overflow Register
0x10E0	TIMER_DTCFG_SET	RW CONFIG	DTI Configuration Register
0x10E4	TIMER_DTIMECFG_SET	RW CONFIG	DTI Time Configuration Register
0x10E8	TIMER_DTFCFG_SET	RW CONFIG	DTI Fault Configuration Register
0x10EC	TIMER_DTCTRL_SET	RW SYNC	DTI Control Register
0x10F0	TIMER DTOGEN_SET	RW SYNC	DTI Output Generation Enable Register
0x10F4	TIMER_DTFault_SET	RH	DTI Fault Register
0x10F8	TIMER_DTFaultC_SET	W SYNC	DTI Fault Clear Register
0x10FC	TIMER_DTLOCK_SET	W	DTI Configuration Lock Register
0x2000	TIMER_IPVERSION_CLR	R	IP Version ID
0x2004	TIMER_CFG_CLR	RW CONFIG	Configuration Register
0x2008	TIMER_CTRL_CLR	RW SYNC	Control Register
0x200C	TIMER_CMD_CLR	W SYNC	Command Register
0x2010	TIMER_STATUS_CLR	RH	Status Register
0x2014	TIMER_IF_CLR	RWH INTFLAG	Interrupt Flag Register
0x2018	TIMER_IEN_CLR	RW	Interrupt Enable Register
0x201C	TIMER_TOP_CLR	RWH SYNC	Counter Top Value Register
0x2020	TIMER_TOPB_CLR	RW SYNC	Counter Top Value Buffer Register
0x2024	TIMER_CNT_CLR	RWH SYNC	Counter Value Register
0x202C	TIMER_LOCK_CLR	W	TIMER Configuration Lock Register
0x2030	TIMER_EN_CLR	RW ENABLE	Module En
0x2060	TIMER_CCx_CFG_CLR	RW CONFIG	CC Channel Configuration Register
0x2064	TIMER_CCx_CTRL_CLR	RW SYNC	CC Channel Control Register
0x2068	TIMER_CCx_OC_CLR	RWH SYNC	OC Channel Value Register
0x2070	TIMER_CCx_OCB_CLR	RW SYNC	OC Channel Value Buffer Register
0x2074	TIMER_CCx_ICF_CLR	RH(r)	IC Channel Value Register
0x2078	TIMER_CCx_ICOF_CLR	RH SYNC	IC Channel Value Overflow Register
0x20E0	TIMER_DTCFG_CLR	RW CONFIG	DTI Configuration Register
0x20E4	TIMER_DTIMECFG_CLR	RW CONFIG	DTI Time Configuration Register

Offset	Name	Type	Description
0x20E8	TIMER_DTFCFG_CLR	RW CONFIG	DTI Fault Configuration Register
0x20EC	TIMER_DTCTRL_CLR	RW SYNC	DTI Control Register
0x20F0	TIMER DTOGEN_CLR	RW SYNC	DTI Output Generation Enable Register
0x20F4	TIMER_DTFault_CLR	RH	DTI Fault Register
0x20F8	TIMER_DTFaultC_CLR	W SYNC	DTI Fault Clear Register
0x20FC	TIMER_DTLOCK_CLR	W	DTI Configuration Lock Register
0x3000	TIMER_IPVERSION_TGL	R	IP Version ID
0x3004	TIMER_CFG_TGL	RW CONFIG	Configuration Register
0x3008	TIMER_CTRL_TGL	RW SYNC	Control Register
0x300C	TIMER_CMD_TGL	W SYNC	Command Register
0x3010	TIMER_STATUS_TGL	RH	Status Register
0x3014	TIMER_IF_TGL	RWH INTFLAG	Interrupt Flag Register
0x3018	TIMER_IEN_TGL	RW	Interrupt Enable Register
0x301C	TIMER_TOP_TGL	RWH SYNC	Counter Top Value Register
0x3020	TIMER_TOPB_TGL	RW SYNC	Counter Top Value Buffer Register
0x3024	TIMER_CNT_TGL	RWH SYNC	Counter Value Register
0x302C	TIMER_LOCK_TGL	W	TIMER Configuration Lock Register
0x3030	TIMER_EN_TGL	RW ENABLE	Module En
0x3060	TIMER_CCx_CFG_TGL	RW CONFIG	CC Channel Configuration Register
0x3064	TIMER_CCx_CTRL_TGL	RW SYNC	CC Channel Control Register
0x3068	TIMER_CCx_OC_TGL	RWH SYNC	OC Channel Value Register
0x3070	TIMER_CCx_OCB_TGL	RW SYNC	OC Channel Value Buffer Register
0x3074	TIMER_CCx_ICF_TGL	RH(r)	IC Channel Value Register
0x3078	TIMER_CCx_ICOF_TGL	RH SYNC	IC Channel Value Overflow Register
0x30E0	TIMER_DTFCFG_TGL	RW CONFIG	DTI Configuration Register
0x30E4	TIMER_DTIMECFG_TGL	RW CONFIG	DTI Time Configuration Register
0x30E8	TIMER_DTFCFG_TGL	RW CONFIG	DTI Fault Configuration Register
0x30EC	TIMER_DTCTRL_TGL	RW SYNC	DTI Control Register
0x30F0	TIMER DTOGEN_TGL	RW SYNC	DTI Output Generation Enable Register
0x30F4	TIMER_DTFault_TGL	RH	DTI Fault Register
0x30F8	TIMER_DTFaultC_TGL	W SYNC	DTI Fault Clear Register
0x30FC	TIMER_DTLOCK_TGL	W	DTI Configuration Lock Register

19.5 TIMER Register Description

19.5.1 TIMER_IPVERSION - IP Version ID

Offset	Bit Position																															
0x000	31	30	29	28	27	26	25	24	23	22	21	20	19	18	17	16	15	14	13	12	11	10	9	8	7	6	5	4	3	2	1	0
Reset																	0x1															
Access																	R															
Name																	IPVERSION															

Bit	Name	Reset	Access	Description
31:0	IPVERSION	0x1	R	IP Version ID The read only IPVERSION field gives the version for this module. There may be minor software changes required for modules with different values of IPVERSION.

19.5.2 TIMER_CFG - Configuration Register

Offset	Bit Position																																															
0x004	31	30	29	28	27	26	25	24	23	22	21	20	19	18	17	16	15	14	13	12	11	10	9	8	7	6	5	4	3	2	1	0																
Reset	0x0																0x0	0x0											0x0	0x0	0x0	0x0	0x0	0x0	0x0	0x0	0x0	0x0										
Access	RW																RW	RW											RW	RW	RW	RW	RW	RW	RW	RW	RW	RW	RW	RW								
Name	PRESC																RSSCOIST	ATI											RETIMESSEL	DISSYNCOOUT	RETIMEEN	CLKSEL	DMACTRACT	DEBGRUN	QDM	OSMEN	SYNC											MODE

Bit	Name	Reset	Access	Description
31:28	<i>Reserved</i>	<i>To ensure compatibility with future devices, always write Reserved bits to their reset value, unless otherwise stated. More information in 1.2 Conventions</i>		
27:18	PRESC	0x0	RW	Prescaler Setting These bits select the prescaling factor for the counter clock. The selected timer clock will be divided by PRESC+1 before clocking the counter. The following modes are provided for easier software porting from Series 0 or Series 1 devices. However, the prescaler is not limited to these options.
	Value	Mode		Description
	0	DIV1		No prescaling
	1	DIV2		Prescale by 2
	3	DIV4		Prescale by 4
	7	DIV8		Prescale by 8
	15	DIV16		Prescale by 16
	31	DIV32		Prescale by 32
	63	DIV64		Prescale by 64
	127	DIV128		Prescale by 128
	255	DIV256		Prescale by 256
	511	DIV512		Prescale by 512
	1023	DIV1024		Prescale by 1024
17	RSSCOIST	0x0	RW	Reload-Start Sets COIST When enabled, compare output is set to COIST value on a Reload-Start event.
16	ATI	0x0	RW	Always Track Inputs Enabling ATI makes CCPOL always track the polarity of the inputs.
15:13	<i>Reserved</i>	<i>To ensure compatibility with future devices, always write Reserved bits to their reset value, unless otherwise stated. More information in 1.2 Conventions</i>		
12	RETIMESSEL	0x0	RW	PWM output retime select When RETIMEEN is set, the PWM output stage will be re-timed to synchronize edges with radio clocks and reduce RF interference. This will introduce up to 1 cycle of clock jitter between PWM outputs.
11	DISSYNCOOUT	0x0	RW	Disable Timer Start/Stop/Reload output When this bit is set, the Timer does not start/stop/reload other timers with SYNC bit set.

Bit	Name	Reset	Access	Description
	Value	Mode		Description
	0	EN		Timer can start/stop/reload other timers with SYNC bit set
	1	DIS		Timer cannot start/stop/reload other timers with SYNC bit set
10	RETIMEEN	0x0	RW	PWM output retimed enable Enable retiming of PWM output.
	Value	Mode		Description
	0	DISABLE		PWM outputs are not re-timed.
	1	ENABLE		PWM outputs are re-timed.
9:8	CLKSEL	0x0	RW	Clock Source Select These bits select the clock source for the timer.
	Value	Mode		Description
	0	PRESCM01GRPACLK		Prescaled EM01GRPACLK
	1	CC1		Compare/Capture Channel 1 Input
	2	TIMEROUF		Timer is clocked by underflow(down-count) or overflow(up-count) in the lower numbered neighbor Timer
7	DMACLRACT	0x0	RW	DMA Request Clear on Active When this bit is set, the DMA requests are cleared when the corresponding DMA channel is active. This enables the timer DMA requests to be cleared without accessing the timer.
6	DEBUGRUN	0x0	RW	Debug Mode Run Enable Set this bit to enable timer to run in debug mode.
	Value	Mode		Description
	0	HALT		Timer is halted in debug mode
	1	RUN		Timer is running in debug mode
5	QDM	0x0	RW	Quadrature Decoder Mode Selection This bit sets the mode for the quadrature decoder.
	Value	Mode		Description
	0	X2		X2 mode selected
	1	X4		X4 mode selected
4	OSMEN	0x0	RW	One-shot Mode Enable Enable/disable one shot mode.
3	SYNC	0x0	RW	Timer Start/Stop/Reload Synchronization When this bit is set, the Timer is started/stopped/reloaded by start/stop/reload commands in the other timers.
	Value	Mode		Description
	0	DISABLE		Timer operation is unaffected by other timers.

Bit	Name	Reset	Access	Description
1		ENABLE		Timer may be started, stopped and re-loaded from other timer instances.
2	<i>Reserved</i>	<i>To ensure compatibility with future devices, always write Reserved bits to their reset value, unless otherwise stated. More information in 1.2 Conventions</i>		
1:0	MODE	0x0	RW	Timer Mode
These bits set the counting mode for the Timer. Note, when Quadrature Decoder Mode is selected (MODE = 'b11), the CLKSEL is don't care. The Timer is clocked by the Decoder Mode clock output.				
	Value	Mode	Description	
	0	UP	Up-count mode	
	1	DOWN	Down-count mode	
	2	UPDOWN	Up/down-count mode	
	3	QDEC	Quadrature decoder mode	

19.5.3 TIMER_CTRL - Control Register

Offset	Bit Position																															
0x008	31	30	29	28	27	26	25	24	23	22	21	20	19	18	17	16	15	14	13	12	11	10	9	8	7	6	5	4	3	2	1	0
Reset																												0x0	0x0	0x0		
Access																												RW	RW	RW		
Name																												X2CNT	FALLA	RISEA		

Bit	Name	Reset	Access	Description
31:5	<i>Reserved</i>	<i>To ensure compatibility with future devices, always write Reserved bits to their reset value, unless otherwise stated. More information in 1.2 Conventions</i>		
4	X2CNT	0x0	RW	2x Count Mode Enable 2x count mode
3:2	FALLA	0x0	RW	Timer Falling Input Edge Action These bits select the action taken in the counter when a falling edge occurs on the input.
	Value	Mode		Description
	0	NONE		No action
	1	START		Start counter without reload
	2	STOP		Stop counter without reload
	3	RELOADSTART		Reload and start counter
1:0	RISEA	0x0	RW	Timer Rising Input Edge Action These bits select the action taken in the counter when a rising edge occurs on the input.
	Value	Mode		Description
	0	NONE		No action
	1	START		Start counter without reload
	2	STOP		Stop counter without reload
	3	RELOADSTART		Reload and start counter

19.5.4 TIMER_CMD - Command Register

Offset	Bit Position																															
0x00C	31	30	29	28	27	26	25	24	23	22	21	20	19	18	17	16	15	14	13	12	11	10	9	8	7	6	5	4	3	2	1	0
Reset																															0x0	0x0
Access																															W(nB)	W(nB)
Name																															STOP	START

Bit	Name	Reset	Access	Description
31:2	<i>Reserved</i>	<i>To ensure compatibility with future devices, always write Reserved bits to their reset value, unless otherwise stated. More information in 1.2 Conventions</i>		
1	STOP Write a 1 to this bit to stop timer	0x0	W(nB)	Stop Timer
0	START Write a 1 to this bit to start timer	0x0	W(nB)	Start Timer

19.5.5 TIMER_STATUS - Status Register

Offset	Bit Position																															
0x010	31	30	29	28	27	26	25	24	23	22	21	20	19	18	17	16	15	14	13	12	11	10	9	8	7	6	5	4	3	2	1	0
Reset						0x0	0x0	0x0						0x0	0x0	0x0						0x0	0x0	0x0		0x0	0x0	0x0		0x0	0x0	0x0
Access						R	R	R						R	R	R						R	R	R		R	R	R		R	R	R
Name						CCPOL2	CCPOL1	CCPOL0						ICFEMPTY2	ICFEMPTY1	ICFEMPTY0						OCBV2	OCBV1	OCBV0		SYNCBUSY	DTILOCKSTATUS	TIMERLOCKSTATUS		TOPBV	DIR	RUNNING

Bit	Name	Reset	Access	Description									
31:27	Reserved	To ensure compatibility with future devices, always write Reserved bits to their reset value, unless otherwise stated. More information in 1.2 Conventions											
26	CCPOL2	0x0	R	Compare/Capture Polarity In Input Capture mode, this bit indicates the polarity of the edge that triggered capture in TIMERNn_CCx_CCv. In Compare/PWM mode, this bit indicates the polarity of the selected input to CC channel x. These bits are cleared when CCMODE is written to 0b00 (Off). <table border="1"> <thead> <tr> <th>Value</th> <th>Mode</th> <th>Description</th> </tr> </thead> <tbody> <tr> <td>0</td> <td>LOWRISE</td> <td>CCx polarity low level/rising edge</td> </tr> <tr> <td>1</td> <td>HIGHFALL</td> <td>CCx polarity high level/falling edge</td> </tr> </tbody> </table>	Value	Mode	Description	0	LOWRISE	CCx polarity low level/rising edge	1	HIGHFALL	CCx polarity high level/falling edge
Value	Mode	Description											
0	LOWRISE	CCx polarity low level/rising edge											
1	HIGHFALL	CCx polarity high level/falling edge											
25	CCPOL1	0x0	R	Compare/Capture Polarity In Input Capture mode, this bit indicates the polarity of the edge that triggered capture in TIMERNn_CCx_CCv. In Compare/PWM mode, this bit indicates the polarity of the selected input to CC channel x. These bits are cleared when CCMODE is written to 0b00 (Off). <table border="1"> <thead> <tr> <th>Value</th> <th>Mode</th> <th>Description</th> </tr> </thead> <tbody> <tr> <td>0</td> <td>LOWRISE</td> <td>CCx polarity low level/rising edge</td> </tr> <tr> <td>1</td> <td>HIGHFALL</td> <td>CCx polarity high level/falling edge</td> </tr> </tbody> </table>	Value	Mode	Description	0	LOWRISE	CCx polarity low level/rising edge	1	HIGHFALL	CCx polarity high level/falling edge
Value	Mode	Description											
0	LOWRISE	CCx polarity low level/rising edge											
1	HIGHFALL	CCx polarity high level/falling edge											
24	CCPOL0	0x0	R	Compare/Capture Polarity In Input Capture mode, this bit indicates the polarity of the edge that triggered capture in TIMERNn_CCx_CCv. In Compare/PWM mode, this bit indicates the polarity of the selected input to CC channel x. These bits are cleared when CCMODE is written to 0b00 (Off). <table border="1"> <thead> <tr> <th>Value</th> <th>Mode</th> <th>Description</th> </tr> </thead> <tbody> <tr> <td>0</td> <td>LOWRISE</td> <td>CCx polarity low level/rising edge</td> </tr> <tr> <td>1</td> <td>HIGHFALL</td> <td>CCx polarity high level/falling edge</td> </tr> </tbody> </table>	Value	Mode	Description	0	LOWRISE	CCx polarity low level/rising edge	1	HIGHFALL	CCx polarity high level/falling edge
Value	Mode	Description											
0	LOWRISE	CCx polarity low level/rising edge											
1	HIGHFALL	CCx polarity high level/falling edge											
23:19	Reserved	To ensure compatibility with future devices, always write Reserved bits to their reset value, unless otherwise stated. More information in 1.2 Conventions											
18	ICFEMPTY2	0x0	R	Input capture fifo empty Set when input capture FIFO is empty									

Bit	Name	Reset	Access	Description
17	ICFEMPTY1	0x0	R	Input capture fifo empty Set when input capture FIFO is empty
16	ICFEMPTY0	0x0	R	Input capture fifo empty Set when input capture FIFO is empty
15:11	<i>Reserved</i>	<i>To ensure compatibility with future devices, always write Reserved bits to their reset value, unless otherwise stated. More information in 1.2 Conventions</i>		
10	OCBV2	0x0	R	Output Compare Buffer Valid This field indicates that the TIMERNn_CCx_CCVB registers contain data which have not been written to TIMERNn_CCx_CCv. These bits are only used in OUTPUTCOMPARE or PWM mode and are cleared when CCMODE is written to 0b00 (Off).
9	OCBV1	0x0	R	Output Compare Buffer Valid This field indicates that the TIMERNn_CCx_CCVB registers contain data which have not been written to TIMERNn_CCx_CCv. These bits are only used in OUTPUTCOMPARE or PWM mode and are cleared when CCMODE is written to 0b00 (Off).
8	OCBV0	0x0	R	Output Compare Buffer Valid This field indicates that the TIMERNn_CCx_CCVB registers contain data which have not been written to TIMERNn_CCx_CCv. These bits are only used in OUTPUTCOMPARE or PWM mode and are cleared when CCMODE is written to 0b00 (Off).
7	<i>Reserved</i>	<i>To ensure compatibility with future devices, always write Reserved bits to their reset value, unless otherwise stated. More information in 1.2 Conventions</i>		
6	SYNCBUSY	0x0	R	Sync Busy Indicates synchronization ongoing
5	DTILOCKSTATUS	0x0	R	DTI lock status Indicates current status of DTI lock
	Value	Mode	Description	
	0	UNLOCKED	DTI registers are unlocked	
	1	LOCKED	DTI registers are locked	
4	TIMERLOCKSTATUS	0x0	R	Timer lock status Indicates current status of Timer lock
	Value	Mode	Description	
	0	UNLOCKED	TIMER registers are unlocked	
	1	LOCKED	TIMER registers are locked	
3	<i>Reserved</i>	<i>To ensure compatibility with future devices, always write Reserved bits to their reset value, unless otherwise stated. More information in 1.2 Conventions</i>		
2	TOPBV	0x0	R	TOP Buffer Valid This indicates that TIMERNn_TOPB contains valid data that has not been written to TIMERNn_TOP. This bit is also cleared when TIMERNn_TOP is written.
1	DIR	0x0	R	Direction Indicates count direction.
	Value	Mode	Description	

Bit	Name	Reset	Access	Description
	0	UP		Counting up
	1	DOWN		Counting down
0	RUNNING	0x0	R	Running Indicates if timer is running or not.

19.5.6 TIMER_IF - Interrupt Flag Register

Offset	Bit Position																															
0x014	31	30	29	28	27	26	25	24	23	22	21	20	19	18	17	16	15	14	13	12	11	10	9	8	7	6	5	4	3	2	1	0
Reset						0x0	0x0	0x0		0x0	0x0	0x0		0x0	0x0	0x0										0x0	0x0	0x0		0x0	0x0	0x0
Access						RW	RW	RW		RW	RW	RW		RW	RW	RW										RW	RW	RW		RW	RW	RW
Name						ICFUF2	ICFUF1	ICFUF0		ICFOF2	ICFOF1	ICFOF0		ICFWLFULL2	ICFWLFULL1	ICFWLFULL0										CC2	CC1	CC0		DIRCHG	UF	OF

Bit	Name	Reset	Access	Description
31:27	<i>Reserved</i>			<i>To ensure compatibility with future devices, always write Reserved bits to their reset value, unless otherwise stated. More information in 1.2 Conventions</i>
26	ICFUF2	0x0	RW	Input capture FIFO underflow Indicates that software tried to read an empty FIFO on channel 2.
25	ICFUF1	0x0	RW	Input capture FIFO underflow Indicates that software tried to read an empty FIFO on channel 1.
24	ICFUF0	0x0	RW	Input capture FIFO underflow Indicates that software tried to read an empty FIFO on channel 0.
23	<i>Reserved</i>			<i>To ensure compatibility with future devices, always write Reserved bits to their reset value, unless otherwise stated. More information in 1.2 Conventions</i>
22	ICFOF2	0x0	RW	Input Capture FIFO overflow Indicates that input capture FIFO for channel 2 has overflowed, and a prior captured value was lost. The latest captured value can be read from the ICOF register.
21	ICFOF1	0x0	RW	Input Capture FIFO overflow Indicates that input capture FIFO for channel 1 has overflowed, and a prior captured value was lost. The latest captured value can be read from the ICOF register.
20	ICFOF0	0x0	RW	Input Capture FIFO overflow Indicates that input capture FIFO for channel 0 has overflowed, and a prior captured value was lost. The latest captured value can be read from the ICOF register.
19	<i>Reserved</i>			<i>To ensure compatibility with future devices, always write Reserved bits to their reset value, unless otherwise stated. More information in 1.2 Conventions</i>
18	ICFWLFULL2	0x0	RW	Input Capture Watermark Level Full This bit indicates that the Input capture FIFO watermark for channel 2 has been exceeded.
17	ICFWLFULL1	0x0	RW	Input Capture Watermark Level Full This bit indicates that the Input capture FIFO watermark for channel 1 has been exceeded.
16	ICFWLFULL0	0x0	RW	Input Capture Watermark Level Full This bit indicates that the Input capture FIFO watermark for channel 0 has been exceeded.
15:7	<i>Reserved</i>			<i>To ensure compatibility with future devices, always write Reserved bits to their reset value, unless otherwise stated. More information in 1.2 Conventions</i>
6	CC2	0x0	RW	Capture Compare Channel 2 Interrupt Flag

Bit	Name	Reset	Access	Description
				In INPUT CAPTURE mode this bit indicates that a new Capture event has taken place. In OUTPUTCOMPARE or PWM mode this bit indicates that a match event has taken place
5	CC1	0x0	RW	Capture Compare Channel 1 Interrupt Flag In INPUT CAPTURE mode this bit indicates that a new Capture event has taken place. In OUTPUTCOMPARE or PWM mode this bit indicates that a match event has taken place
4	CC0	0x0	RW	Capture Compare Channel 0 Interrupt Flag In INPUT CAPTURE mode this bit indicates that a new Capture event has taken place. In OUTPUTCOMPARE or PWM mode this bit indicates that a match event has taken place
3	<i>Reserved</i>	<i>To ensure compatibility with future devices, always write Reserved bits to their reset value, unless otherwise stated. More information in 1.2 Conventions</i>		
2	DIRCHG	0x0	RW	Direction Change Detect Interrupt Flag This bit is set when count direction changes. Set only in Quadrature Decoder mode
1	UF	0x0	RW	Underflow Interrupt Flag This bit indicates that there has been an underflow.
0	OF	0x0	RW	Overflow Interrupt Flag This bit indicates that there has been an overflow.

19.5.7 TIMER_IEN - Interrupt Enable Register

Offset	Bit Position																																				
0x018	31	30	29	28	27	26	25	24	23	22	21	20	19	18	17	16	15	14	13	12	11	10	9	8	7	6	5	4	3	2	1	0					
Reset						0x0	0x0	0x0		0x0	0x0	0x0		0x0	0x0	0x0											0x0	0x0	0x0		0x0	0x0	0x0		0x0	0x0	0x0
Access						RW	RW	RW		RW	RW	RW		RW	RW	RW											RW	RW	RW		RW	RW	RW				
Name						ICFUF2	ICFUF1	ICFUF0		ICFOF2	ICFOF1	ICFOF0		ICFWLFULL2	ICFWLFULL1	ICFWLFULL0											CC2	CC1	CC0		DIRCHG	UF	OF				

Bit	Name	Reset	Access	Description
31:27	<i>Reserved</i>	<i>To ensure compatibility with future devices, always write Reserved bits to their reset value, unless otherwise stated. More information in 1.2 Conventions</i>		
26	ICFUF2	0x0	RW	ICFUF2 Interrupt Enable Enable/Disable the ICFUF2 interrupt
25	ICFUF1	0x0	RW	ICFUF1 Interrupt Enable Enable/Disable the ICFUF1 interrupt
24	ICFUF0	0x0	RW	ICFUF0 Interrupt Enable Enable/Disable the ICFUF0 interrupt
23	<i>Reserved</i>	<i>To ensure compatibility with future devices, always write Reserved bits to their reset value, unless otherwise stated. More information in 1.2 Conventions</i>		
22	ICFOF2	0x0	RW	ICFOF2 Interrupt Enable Enable/Disable the ICFOF2 interrupt
21	ICFOF1	0x0	RW	ICFOF1 Interrupt Enable Enable/Disable the ICFOF1 interrupt
20	ICFOF0	0x0	RW	ICFOF0 Interrupt Enable Enable/Disable the ICFOF0 interrupt
19	<i>Reserved</i>	<i>To ensure compatibility with future devices, always write Reserved bits to their reset value, unless otherwise stated. More information in 1.2 Conventions</i>		
18	ICFWLFULL2	0x0	RW	ICFWLFULL2 Interrupt Enable Enable/Disable the ICFWLFULL2 interrupt
17	ICFWLFULL1	0x0	RW	ICFWLFULL1 Interrupt Enable Enable/Disable the ICFWLFULL1 interrupt
16	ICFWLFULL0	0x0	RW	ICFWLFULL0 Interrupt Enable Enable/Disable the ICFWLFULL0 interrupt
15:7	<i>Reserved</i>	<i>To ensure compatibility with future devices, always write Reserved bits to their reset value, unless otherwise stated. More information in 1.2 Conventions</i>		
6	CC2	0x0	RW	CC2 Interrupt Enable Enable/Disable the CC2 interrupt
5	CC1	0x0	RW	CC1 Interrupt Enable

Bit	Name	Reset	Access	Description
				Enable/Disable the CC1 interrupt
4	CC0	0x0	RW	CC0 Interrupt Enable Enable/Disable the CC0 interrupt
3	<i>Reserved</i>	<i>To ensure compatibility with future devices, always write Reserved bits to their reset value, unless otherwise stated. More information in 1.2 Conventions</i>		
2	DIRCHG	0x0	RW	Direction Change Detect Interrupt Enable Enable/Disable the DIRCHG interrupt
1	UF	0x0	RW	Underflow Interrupt Enable Enable/Disable the UF interrupt
0	OF	0x0	RW	Overflow Interrupt Enable Enable/Disable the OF interrupt

19.5.8 TIMER_TOP - Counter Top Value Register

Offset	Bit Position																															
0x01C	31	30	29	28	27	26	25	24	23	22	21	20	19	18	17	16	15	14	13	12	11	10	9	8	7	6	5	4	3	2	1	0
Reset	0xFFFF																															
Access	RW																															
Name	TOP																															

Bit	Name	Reset	Access	Description
31:0	TOP	0xFFFF	RW	Counter Top Value These bits hold the TOP value for the counter

19.5.9 TIMER_TOPB - Counter Top Value Buffer Register

Offset	Bit Position																															
0x020	31	30	29	28	27	26	25	24	23	22	21	20	19	18	17	16	15	14	13	12	11	10	9	8	7	6	5	4	3	2	1	0
Reset	0x0																															
Access	RW																															
Name	TOPB																															

Bit	Name	Reset	Access	Description
31:0	TOPB	0x0	RW	Counter Top Buffer Register These bits hold the TOP buffer value.

19.5.10 TIMER_CNT - Counter Value Register

Offset	Bit Position																															
0x024	31	30	29	28	27	26	25	24	23	22	21	20	19	18	17	16	15	14	13	12	11	10	9	8	7	6	5	4	3	2	1	0
Reset																0x0																
Access																RW																
Name																CNT																

Bit	Name	Reset	Access	Description
31:0	CNT	0x0	RW	Counter Value
These bits hold the counter value.				

19.5.11 TIMER_LOCK - TIMER Configuration Lock Register

Offset	Bit Position																															
0x02C	31	30	29	28	27	26	25	24	23	22	21	20	19	18	17	16	15	14	13	12	11	10	9	8	7	6	5	4	3	2	1	0
Reset																0x0																
Access																W																
Name																LOCKKEY																

Bit	Name	Reset	Access	Description
31:16	<i>Reserved</i>	<i>To ensure compatibility with future devices, always write Reserved bits to their reset value, unless otherwise stated. More information in 1.2 Conventions</i>		
15:0	LOCKKEY	0x0	W	Timer Lock Key
Write any other value than the unlock code to lock TIMERn_CTRL, TIMERn_CFG, TIMERn_CMD, TIMERn_TOP, TIMERn_CNT, TIMERn_CCx_CTRL, TIMERn_CCx_CFG, and TIMERn_CCx_OC from editing. Write the unlock code to unlock these registers.				
	Value	Mode	Description	
	52864	UNLOCK	Write to unlock TIMER registers	

19.5.12 TIMER_EN - Module En

Offset	Bit Position																															
0x030	31	30	29	28	27	26	25	24	23	22	21	20	19	18	17	16	15	14	13	12	11	10	9	8	7	6	5	4	3	2	1	0
Reset																													0x0	0x0		
Access																													R	RW		
Name																													DISABLING	EN		

Bit	Name	Reset	Access	Description
31:2	Reserved	To ensure compatibility with future devices, always write Reserved bits to their reset value, unless otherwise stated. More information in 1.2 Conventions		
1	DISABLING	0x0	R	<p>Disablement busy status</p> <p>When EN is cleared, DISABLING status is set immediately, and cleared when disablement finishes. Disablement resets peripheral cores and not APB registers except hardware updated registers such as INTFLAGS and FIFO</p>
0	EN	0x0	RW	<p>Timer Module Enable</p> <p>The ENABLE bit enables the module. Software should write to CONFIG type registers before setting the ENABLE bit. Software should write to SYNC type registers only after setting the ENABLE bit.</p>

19.5.13 TIMER_CCx_CFG - CC Channel Configuration Register

Offset	Bit Position																															
0x060	31	30	29	28	27	26	25	24	23	22	21	20	19	18	17	16	15	14	13	12	11	10	9	8	7	6	5	4	3	2	1	0
Reset												0x0	0x0	0x0	0x0												0x0			0x0		
Access												RW	RW	RW	RW												RW			RW		
Name												ICFWL	FILT	PRSCONF	INSEL												COIST			MODE		

Bit	Name	Reset	Access	Description
31:22	<i>Reserved</i>	<i>To ensure compatibility with future devices, always write Reserved bits to their reset value, unless otherwise stated. More information in 1.2 Conventions</i>		
21	ICFWL	0x0	RW	Input Capture FIFO watermark level Sets the watermark level for generation of the ICFWLFULL interrupt and DMA requests. ICFWLFULL will be set and DMA requests may be generated if the number of free FIFO entries is less than or equal to ICFWL.
20	FILT	0x0	RW	Digital Filter Enable digital filter.
	Value	Mode		Description
	0	DISABLE		Digital Filter Disabled
	1	ENABLE		Digital Filter Enabled
19	PRSCONF	0x0	RW	PRS Configuration Select PRS pulse or level for PRS output.
	Value	Mode		Description
	0	PULSE		Each CC event will generate a one EM01GRPACLK cycle high pulse
	1	LEVEL		The PRS channel will follow CC out
18:17	INSEL	0x0	RW	Input Selection Select Compare/Capture channel input.
	Value	Mode		Description
	0	PIN		TIMERnCCx pin is selected
	1	PRSSYNC		Synchronous PRS selected
	2	PRSASYNCLEVEL		Asynchronous Level PRS selected
	3	PRSASYNCPULSE		Asynchronous Pulse PRS selected
16:5	<i>Reserved</i>	<i>To ensure compatibility with future devices, always write Reserved bits to their reset value, unless otherwise stated. More information in 1.2 Conventions</i>		
4	COIST	0x0	RW	Compare Output Initial State

Bit	Name	Reset	Access	Description
				This bit is only used in Output Compare and PWM mode. When this bit is set in Compare or PWM mode, the output is set high when the counter is disabled. When counting resumes, this value will represent the initial value for the output. If the bit is cleared, the output will be cleared when the counter is disabled.
3:2	<i>Reserved</i>	<i>To ensure compatibility with future devices, always write Reserved bits to their reset value, unless otherwise stated. More information in 1.2 Conventions</i>		

1:0	MODE	0x0	RW	CC Channel Mode
-----	------	-----	----	------------------------

These bits select the mode for Compare/Capture channel.

Value	Mode	Description
0	OFF	Compare/Capture channel turned off
1	INPUTCAPTURE	Input Capture
2	OUTPUTCOMPARE	Output Compare
3	PWM	Pulse-Width Modulation

19.5.14 TIMER_CCx_CTRL - CC Channel Control Register

Offset	Bit Position																															
0x064	31	30	29	28	27	26	25	24	23	22	21	20	19	18	17	16	15	14	13	12	11	10	9	8	7	6	5	4	3	2	1	0
Reset					0x0	0x0												0x0	0x0		0x0									0x0		
Access					RW	RW												RW	RW		RW									RW		
Name					ICEVCTRL	ICEDGE												CUFOA	COFOA		CMOA									OUTINV		

Bit	Name	Reset	Access	Description															
31:28	<i>Reserved</i>	<i>To ensure compatibility with future devices, always write Reserved bits to their reset value, unless otherwise stated. More information in 1.2 Conventions</i>																	
27:26	ICEVCTRL	0x0	RW	Input Capture Event Control These bits control when a Compare/Capture PRS output pulse and interrupt flag is set. DMA request however is set on every capture. <table border="1"> <thead> <tr> <th>Value</th> <th>Mode</th> <th>Description</th> </tr> </thead> <tbody> <tr> <td>0</td> <td>EVERYEDGE</td> <td>PRS output pulse and interrupt flag set on every capture</td> </tr> <tr> <td>1</td> <td>EVERYSECONDEEDGE</td> <td>PRS output pulse and interrupt flag set on every second capture</td> </tr> <tr> <td>2</td> <td>RISING</td> <td>PRS output pulse and interrupt flag set on rising edge only (if ICEDGE = BOTH)</td> </tr> <tr> <td>3</td> <td>FALLING</td> <td>PRS output pulse and interrupt flag set on falling edge only (if ICEDGE = BOTH)</td> </tr> </tbody> </table>	Value	Mode	Description	0	EVERYEDGE	PRS output pulse and interrupt flag set on every capture	1	EVERYSECONDEEDGE	PRS output pulse and interrupt flag set on every second capture	2	RISING	PRS output pulse and interrupt flag set on rising edge only (if ICEDGE = BOTH)	3	FALLING	PRS output pulse and interrupt flag set on falling edge only (if ICEDGE = BOTH)
Value	Mode	Description																	
0	EVERYEDGE	PRS output pulse and interrupt flag set on every capture																	
1	EVERYSECONDEEDGE	PRS output pulse and interrupt flag set on every second capture																	
2	RISING	PRS output pulse and interrupt flag set on rising edge only (if ICEDGE = BOTH)																	
3	FALLING	PRS output pulse and interrupt flag set on falling edge only (if ICEDGE = BOTH)																	
25:24	ICEDGE	0x0	RW	Input Capture Edge Select These bits control which edges the edge detector triggers on. The output is used for input capture and external clock input. <table border="1"> <thead> <tr> <th>Value</th> <th>Mode</th> <th>Description</th> </tr> </thead> <tbody> <tr> <td>0</td> <td>RISING</td> <td>Rising edges detected</td> </tr> <tr> <td>1</td> <td>FALLING</td> <td>Falling edges detected</td> </tr> <tr> <td>2</td> <td>BOTH</td> <td>Both edges detected</td> </tr> <tr> <td>3</td> <td>NONE</td> <td>No edge detection, signal is left as it is</td> </tr> </tbody> </table>	Value	Mode	Description	0	RISING	Rising edges detected	1	FALLING	Falling edges detected	2	BOTH	Both edges detected	3	NONE	No edge detection, signal is left as it is
Value	Mode	Description																	
0	RISING	Rising edges detected																	
1	FALLING	Falling edges detected																	
2	BOTH	Both edges detected																	
3	NONE	No edge detection, signal is left as it is																	
23:14	<i>Reserved</i>	<i>To ensure compatibility with future devices, always write Reserved bits to their reset value, unless otherwise stated. More information in 1.2 Conventions</i>																	
13:12	CUFOA	0x0	RW	Counter Underflow Output Action Select output action on counter underflow. <table border="1"> <thead> <tr> <th>Value</th> <th>Mode</th> <th>Description</th> </tr> </thead> <tbody> <tr> <td>0</td> <td>NONE</td> <td>No action on counter underflow</td> </tr> <tr> <td>1</td> <td>TOGGLE</td> <td>Toggle output on counter underflow</td> </tr> <tr> <td>2</td> <td>CLEAR</td> <td>Clear output on counter underflow</td> </tr> <tr> <td>3</td> <td>SET</td> <td>Set output on counter underflow</td> </tr> </tbody> </table>	Value	Mode	Description	0	NONE	No action on counter underflow	1	TOGGLE	Toggle output on counter underflow	2	CLEAR	Clear output on counter underflow	3	SET	Set output on counter underflow
Value	Mode	Description																	
0	NONE	No action on counter underflow																	
1	TOGGLE	Toggle output on counter underflow																	
2	CLEAR	Clear output on counter underflow																	
3	SET	Set output on counter underflow																	

Bit	Name	Reset	Access	Description
11:10	COFOA	0x0	RW	Counter Overflow Output Action Select output action on counter overflow.
	Value	Mode		Description
	0	NONE		No action on counter overflow
	1	TOGGLE		Toggle output on counter overflow
	2	CLEAR		Clear output on counter overflow
	3	SET		Set output on counter overflow
9:8	CMOA	0x0	RW	Compare Match Output Action Select output action on compare match.
	Value	Mode		Description
	0	NONE		No action on compare match
	1	TOGGLE		Toggle output on compare match
	2	CLEAR		Clear output on compare match
	3	SET		Set output on compare match
7:3	<i>Reserved</i>	<i>To ensure compatibility with future devices, always write Reserved bits to their reset value, unless otherwise stated. More information in 1.2 Conventions</i>		
2	OUTINV	0x0	RW	Output Invert Setting this bit inverts the output from the CC channel (Output compare or PWM mode).
1:0	<i>Reserved</i>	<i>To ensure compatibility with future devices, always write Reserved bits to their reset value, unless otherwise stated. More information in 1.2 Conventions</i>		

19.5.15 TIMER_CCx_OC - OC Channel Value Register

Offset	Bit Position																															
0x068	31	30	29	28	27	26	25	24	23	22	21	20	19	18	17	16	15	14	13	12	11	10	9	8	7	6	5	4	3	2	1	0
Reset																0x0																
Access																RW																
Name																OC																

Bit	Name	Reset	Access	Description
31:0	OC	0x0	RW	Output Compare Value This fields holds the output compare value

19.5.16 TIMER_CCx_OCB - OC Channel Value Buffer Register

Offset	Bit Position																															
0x070	31	30	29	28	27	26	25	24	23	22	21	20	19	18	17	16	15	14	13	12	11	10	9	8	7	6	5	4	3	2	1	0
Reset																0x0																
Access																RW																
Name																OCB																

Bit	Name	Reset	Access	Description
31:0	OCB	0x0	RW	Output Compare Value Buffer
This field holds the Output Compare buffer value which will be written to TIMERN_CCx_OC on an update event if TIMERN_CCx_OCB contains valid data				

19.5.17 TIMER_CCx_ICF - IC Channel Value Register

Offset	Bit Position																															
0x074	31	30	29	28	27	26	25	24	23	22	21	20	19	18	17	16	15	14	13	12	11	10	9	8	7	6	5	4	3	2	1	0
Reset																0x0																
Access																R(r)																
Name																ICF																

Bit	Name	Reset	Access	Description
31:0	ICF	0x0	R(r)	Input Capture FIFO
This FIFO holds captured values in input capture mode. Reading this register will pop the oldest unread value from the FIFO.				

19.5.18 TIMER_CCx_ICOF - IC Channel Value Overflow Register

Offset	Bit Position																															
0x078	31	30	29	28	27	26	25	24	23	22	21	20	19	18	17	16	15	14	13	12	11	10	9	8	7	6	5	4	3	2	1	0
Reset																0x0																
Access																R																
Name																ICOF																

Bit	Name	Reset	Access	Description
31:0	ICOF	0x0	R	Input Capture FIFO Overflow
This register always contains the most recent input capture value. If the input capture FIFO is full and a new capture occurs, this register will be updated and the previous capture value is over-written.				

19.5.19 TIMER_DTCFG - DTI Configuration Register

Offset	Bit Position																															
0x0E0	31	30	29	28	27	26	25	24	23	22	21	20	19	18	17	16	15	14	13	12	11	10	9	8	7	6	5	4	3	2	1	0
Reset												0x0	0x0	0x0												0x0	0x0					
Access												RW	RW	RW												RW	RW					
Name												DTPRSEN	DTFATS	DTAR												DTDAS	DTEN					

Bit	Name	Reset	Access	Description
31:12	<i>Reserved</i>	<i>To ensure compatibility with future devices, always write Reserved bits to their reset value, unless otherwise stated. More information in 1.2 Conventions</i>		
11	DTPRSEN	0x0	RW	DTI PRS Source Enable Enable/disable PRS as DTI input.
10	DTFATS	0x0	RW	DTI Fault Action on Timer Stop When Timer stops, DTI block outputs go to safe state as programmed in DTFA field of TIMERN_DTFC register. However, when DTAR is also set, DTAR having higher priority allows channel0 to output the incoming PRS input while the other channels go to safe state
9	DTAR	0x0	RW	DTI Always Run This is used only for DTI channel 0. It Allows DTI channel 0 to keep running even when the timer is stopped. This is useful when its input source is PRS. However, here the undivided peripheral clock is always used regardless of the programmed value in DTPRESC.
8:2	<i>Reserved</i>	<i>To ensure compatibility with future devices, always write Reserved bits to their reset value, unless otherwise stated. More information in 1.2 Conventions</i>		
1	DTDAS	0x0	RW	DTI Automatic Start-up Functionality Configure DTI restart on debugger exit.
	Value	Mode		Description
	0	NORESTART		No DTI restart on debugger exit
	1	RESTART		DTI restart on debugger exit
0	DTEN	0x0	RW	DTI Enable Enable/disable DTI.

19.5.20 TIMER_DTTIMECFG - DTI Time Configuration Register

Offset	Bit Position																															
0x0E4	31	30	29	28	27	26	25	24	23	22	21	20	19	18	17	16	15	14	13	12	11	10	9	8	7	6	5	4	3	2	1	0
Reset												0x0				0x0				0x0												
Access												RW				RW				RW												
Name												DTFALLT				DTRISSET				DTPRESC												

Bit	Name	Reset	Access	Description
31:22	<i>Reserved</i>	<i>To ensure compatibility with future devices, always write Reserved bits to their reset value, unless otherwise stated. More information in 1.2 Conventions</i>		
21:16	DTFALLT	0x0	RW	DTI Fall-time Set time span for the falling edge. The fall time is DTFALLT+1 prescaled peripheral clock cycles
15:10	DTRISSET	0x0	RW	DTI Rise-time Set time span for the rising edge. The rise time is DTRISSET+1 prescaled peripheral clock cycles
9:0	DTPRESC	0x0	RW	DTI Prescaler Setting These bits select the prescaling factor for DTI. The selected timer clock will be divided by DTPRESC+1 before clocking the DTI logic.

19.5.21 TIMER_DTFCFG - DTI Fault Configuration Register

Offset	Bit Position																																
0x0E8	31	30	29	28	27	26	25	24	23	22	21	20	19	18	17	16	15	14	13	12	11	10	9	8	7	6	5	4	3	2	1	0	
Reset				0x0	0x0	0x0	0x0	0x0								0x0																	
Access				RW	RW	RW	RW	RW								RW																	
Name				DTEM23FEN	DTLOCKUPFEN	DTDBGFEN	DTPRS1FEN	DTPRS0FEN								DTFA																	

Bit	Name	Reset	Access	Description
31:29	Reserved			To ensure compatibility with future devices, always write Reserved bits to their reset value, unless otherwise stated. More information in 1.2 Conventions
28	DTEM23FEN	0x0	RW	DTI EM23 Fault Enable Set this bit to 1 to enable EM2 or EM3 entry as a fault source
27	DTLOCKUPFEN	0x0	RW	DTI Lockup Fault Enable Set this bit to 1 to enable core lockup as a fault source
26	DTDBGFEN	0x0	RW	DTI Debugger Fault Enable Set this bit to 1 to enable debugger as a fault source
25	DTPRS1FEN	0x0	RW	DTI PRS 1 Fault Enable Set this bit to 1 to enable PRS source 1 as a fault source
24	DTPRS0FEN	0x0	RW	DTI PRS 0 Fault Enable Set this bit to 1 to enable PRS source 0 as a fault source
23:18	Reserved			To ensure compatibility with future devices, always write Reserved bits to their reset value, unless otherwise stated. More information in 1.2 Conventions
17:16	DTFA	0x0	RW	DTI Fault Action Select fault action.
	Value	Mode		Description
	0	NONE		No action on fault
	1	INACTIVE		Set outputs inactive
	2	CLEAR		Clear outputs
	3	TRISTATE		Tristate outputs
15:0	Reserved			To ensure compatibility with future devices, always write Reserved bits to their reset value, unless otherwise stated. More information in 1.2 Conventions

19.5.22 TIMER_DTCTRL - DTI Control Register

Offset	Bit Position																															
0x0EC	31	30	29	28	27	26	25	24	23	22	21	20	19	18	17	16	15	14	13	12	11	10	9	8	7	6	5	4	3	2	1	0
Reset																													0x0	0x0		
Access																													RW	RW		
Name																													DTIPOL	DTCINV		

Bit	Name	Reset	Access	Description
31:2	<i>Reserved</i>	<i>To ensure compatibility with future devices, always write Reserved bits to their reset value, unless otherwise stated. More information in 1.2 Conventions</i>		
1	DTIPOL Set inactive polarity of outputs	0x0	RW	DTI Inactive Polarity
0	DTCINV DTI Complementary Output Invert.	0x0	RW	DTI Complementary Output Invert.

19.5.23 TIMER_DTOGEN - DTI Output Generation Enable Register

Offset	Bit Position																																																						
0x0F0	31	30	29	28	27	26	25	24	23	22	21	20	19	18	17	16	15	14	13	12	11	10	9	8	7	6	5	4	3	2	1	0																							
Reset																									0x0	0x0	0x0	0x0	0x0	0x0	0x0	0x0	0x0	0x0	0x0	0x0	0x0	0x0	0x0	0x0	0x0	0x0	0x0	0x0	0x0	0x0	0x0	0x0	0x0	0x0	0x0	0x0	0x0	0x0	
Access																									RW	RW	RW	RW	RW	RW	RW	RW	RW	RW	RW	RW	RW	RW	RW	RW	RW	RW	RW	RW	RW	RW	RW	RW	RW	RW	RW	RW	RW	RW	RW
Name																									DTOGCDTI2EN	DTOGCDTI1EN	DTOGCDTI0EN	DTOGCC2EN	DTOGCC1EN	DTOGCC0EN																									

Bit	Name	Reset	Access	Description
31:6	<i>Reserved</i>	<i>To ensure compatibility with future devices, always write Reserved bits to their reset value, unless otherwise stated. More information in 1.2 Conventions</i>		
5	DTOGCDTI2EN	0x0	RW	DTI CDTIn Output Generation Enable This bit enables/disables output generation for the CDTI output from the DTI.
4	DTOGCDTI1EN	0x0	RW	DTI CDTIn Output Generation Enable This bit enables/disables output generation for the CDTI output from the DTI.
3	DTOGCDTI0EN	0x0	RW	DTI CDTIn Output Generation Enable This bit enables/disables output generation for the CDTI output from the DTI.
2	DTOGCC2EN	0x0	RW	DTI CCn Output Generation Enable This bit enables/disables output generation for the CC output from the DTI.
1	DTOGCC1EN	0x0	RW	DTI CCn Output Generation Enable This bit enables/disables output generation for the CC output from the DTI.
0	DTOGCC0EN	0x0	RW	DTI CCn Output Generation Enable This bit enables/disables output generation for the CC output from the DTI.

19.5.24 TIMER_DTFAULT - DTI Fault Register

Offset	Bit Position																															
0x0F4	31	30	29	28	27	26	25	24	23	22	21	20	19	18	17	16	15	14	13	12	11	10	9	8	7	6	5	4	3	2	1	0
Reset																											0x0	0x0	0x0	0x0	0x0	
Access																											R	R	R	R	R	
Name																											DTEM23F	DTLOCKUPF	DTDBGF	DTPRS1F	DTPRS0F	

Bit	Name	Reset	Access	Description
31:5	<i>Reserved</i>	<i>To ensure compatibility with future devices, always write Reserved bits to their reset value, unless otherwise stated. More information in 1.2 Conventions</i>		
4	DTEM23F	0x0	R	DTI EM23 Entry Fault This bit is set to 1 if EM2 or EM3 entry has occurred and DTEM23FEN is set to 1. The TIMER0_DTFAULTC register can be used to clear fault bits.
3	DTLOCKUPF	0x0	R	DTI Lockup Fault This bit is set to 1 if a core lockup fault has occurred and DTLOCKUPFEN is set to 1. The TIMER0_DTFAULTC register can be used to clear fault bits.
2	DTDBGF	0x0	R	DTI Debugger Fault This bit is set to 1 if a debugger fault has occurred and DTDBGFEN is set to 1. The TIMER0_DTFAULTC register can be used to clear fault bits.
1	DTPRS1F	0x0	R	DTI PRS 1 Fault This bit is set to 1 if a PRS 1 fault has occurred and DTPRS1FEN is set to 1. The TIMER0_DTFAULTC register can be used to clear fault bits.
0	DTPRS0F	0x0	R	DTI PRS 0 Fault This bit is set to 1 if a PRS 0 fault has occurred and DTPRS0FEN is set to 1. The TIMER0_DTFAULTC register can be used to clear fault bits.

19.5.25 TIMER_DTFAULTC - DTI Fault Clear Register

Offset	Bit Position																															
0x0F8	31	30	29	28	27	26	25	24	23	22	21	20	19	18	17	16	15	14	13	12	11	10	9	8	7	6	5	4	3	2	1	0
Reset																					0x0	0x0	0x0	0x0	0x0							
Access																					W(nB)	W(nB)	W(nB)	W(nB)	W(nB)							
Name																					DTEM23FC	DTLOCKUPFC	DTDBGFC	DTPRS1FC	DTPRS0FC							

Bit	Name	Reset	Access	Description
31:5	<i>Reserved</i>	<i>To ensure compatibility with future devices, always write Reserved bits to their reset value, unless otherwise stated. More information in 1.2 Conventions</i>		
4	DTEM23FC	0x0	W(nB)	DTI EM23 Fault Clear Write 1 to this bit to clear EM23 entry fault.
3	DTLOCKUPFC	0x0	W(nB)	DTI Lockup Fault Clear Write 1 to this bit to clear core lockup fault.
2	DTDBGFC	0x0	W(nB)	DTI Debugger Fault Clear Write 1 to this bit to clear debugger fault.
1	DTPRS1FC	0x0	W(nB)	DTI PRS1 Fault Clear Write 1 to this bit to clear PRS 1 fault.
0	DTPRS0FC	0x0	W(nB)	DTI PRS0 Fault Clear Write 1 to this bit to clear PRS 0 fault.

19.5.26 TIMER_DTLOCK - DTI Configuration Lock Register

Offset	Bit Position																															
0x0FC	31	30	29	28	27	26	25	24	23	22	21	20	19	18	17	16	15	14	13	12	11	10	9	8	7	6	5	4	3	2	1	0
Reset																	0x0															
Access																	W															
Name																	DTILOCKKEY															

Bit	Name	Reset	Access	Description
31:16	Reserved	To ensure compatibility with future devices, always write Reserved bits to their reset value, unless otherwise stated. More information in 1.2 Conventions		
15:0	DTILOCKKEY	0x0	W	DTI Lock Key Write any other value than the unlock code to lock TIMER_ROUTE, TIMER_DTCTRL, TIMER_DTCFG, TIMER_DTTIMECFG and TIMER_DTF CFG from editing. Write the unlock code to unlock the DTI registers.
	Value	Mode	Description	
	52864	UNLOCK	Write to unlock TIMER DTI registers	

20. USART - Universal Synchronous Asynchronous Receiver/Transmitter

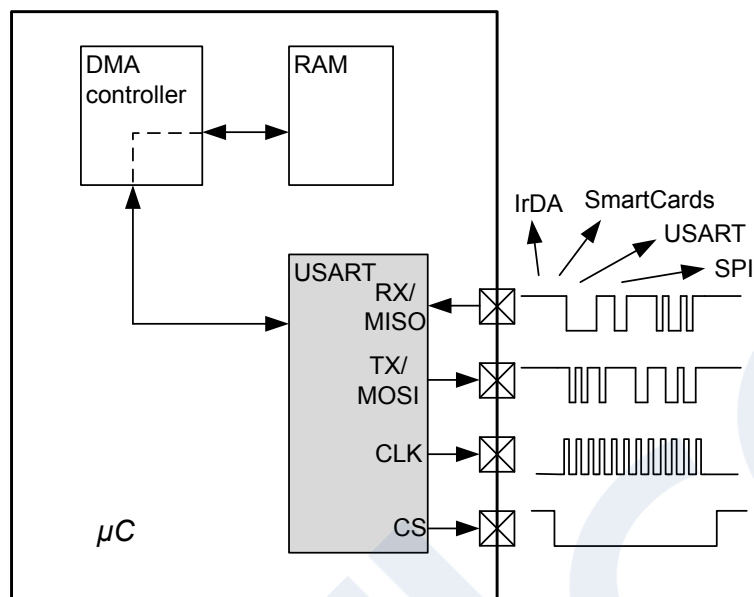
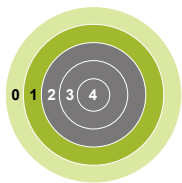

Quick Facts

What?

The USART handles high-speed UART, SPI-bus, SmartCards, and IrDA communication.

Why?

Serial communication is frequently used in embedded systems and the USART allows efficient communication with a wide range of external devices.

How?

The USART has a wide selection of operating modes, frame formats and baud rates. The multi-processor mode allows the USART to remain idle when not addressed. Triple buffering and DMA support makes high data-rates possible with minimal CPU intervention and it is possible to transmit and receive large frames while the MCU remains in EM1 Sleep.

20.1 Introduction

The Universal Synchronous Asynchronous serial Receiver and Transmitter (USART) is a very flexible serial I/O module. It supports full duplex asynchronous UART communication as well as RS-485, SPI, MicroWire and 3-wire. It can also interface with ISO7816 SmartCards, and IrDA devices.

20.2 Features

- Asynchronous and synchronous (SPI) communication
- Full duplex and half duplex
- Separate TX/RX enable
- Separate receive / transmit multiple entry buffers, with additional separate shift registers
- Programmable baud rate, generated as a fractional division from the peripheral clock ($PCLK_{USARTn}$)
- Max bit-rate
 - Main SPI mode, peripheral clock rate/2
 - Secondary SPI mode, peripheral clock rate/6
 - UART mode, peripheral clock rate/16, 8, 6, or 4
- Asynchronous mode supports
 - Majority vote baud-reception
 - False start-bit detection
 - Break generation/detection
 - Multi-processor mode
- Synchronous mode supports
 - All 4 SPI clock polarity/phase configurations
 - Main and Secondary interface modes
- Data can be transmitted LSB first or MSB first
- Configurable number of data bits, 4-16 (plus the parity bit, if enabled)
 - HW parity bit generation and check
- Configurable number of stop bits in asynchronous mode: 0.5, 1, 1.5, 2
- HW collision detection
- Multi-processor mode
- IrDA modulator
- SmartCard (ISO7816) mode
- I2S mode
- Separate interrupt vectors for receive and transmit interrupts
- Loopback mode
 - Half duplex communication
 - Communication debugging
- PRS RX input
- 8 bit Timer
- Hardware Flow Control
- Automatic Baud Rate Detection

20.3 Functional Description

An overview of the USART module is shown in [Figure 20.1 USART Overview on page 563](#).

This section describes all possible USART features. Please refer to the Device Datasheet to see what features a specific USART instance supports.

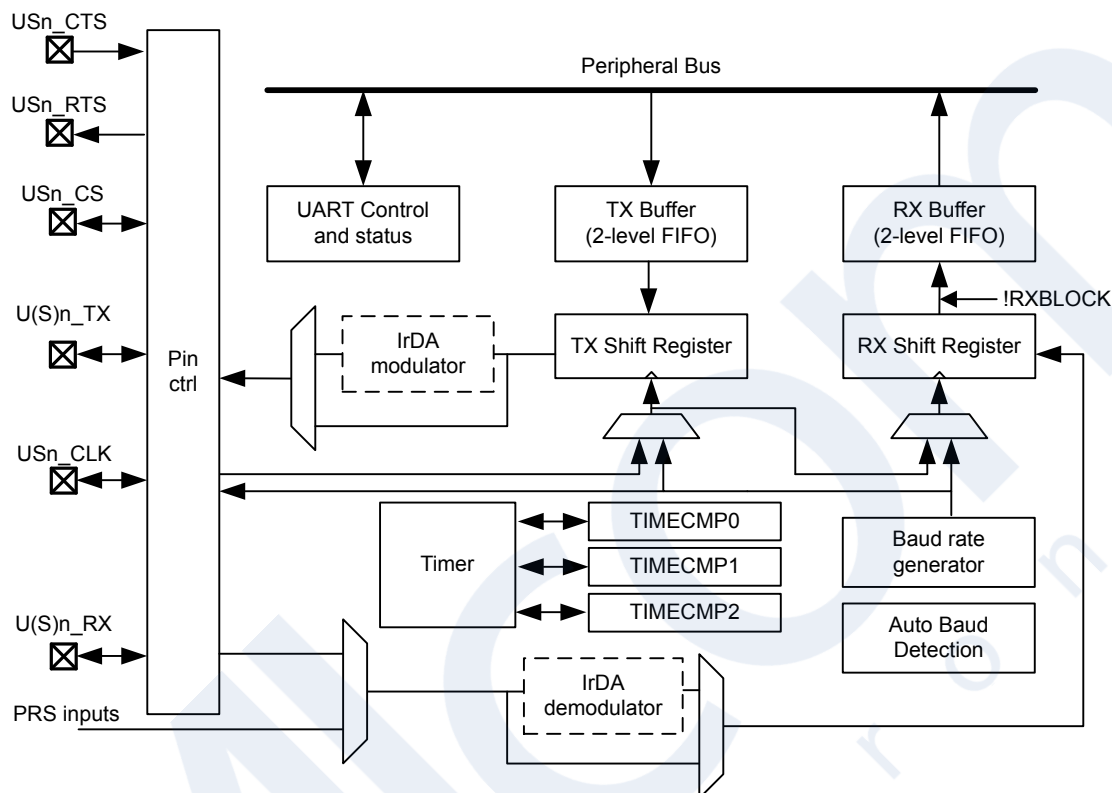

Figure 20.1. USART Overview

20.3.1 Modes of Operation

The USART operates in either asynchronous or synchronous mode.

In synchronous mode, a separate clock signal is transmitted with the data. This clock signal is generated by the main interface on the bus, and both the main and secondary devices sample and transmit data according to this clock. Both main and secondary interface modes are supported by the USART. The synchronous communication mode is compatible with the Serial Peripheral Interface Bus (SPI) standard.

In asynchronous mode, no separate clock signal is transmitted with the data on the bus. The USART receiver thus has to determine where to sample the data on the bus from the actual data. To make this possible, additional synchronization bits are added to the data when operating in asynchronous mode, resulting in a slight overhead.

Asynchronous or synchronous mode can be selected by configuring SYNC in USARTn_CTRL. The options are listed with supported protocols in [Table 20.1 USART Asynchronous vs. Synchronous Mode on page 564](#). Full duplex and half duplex communication is supported in both asynchronous and synchronous mode.

Table 20.1. USART Asynchronous vs. Synchronous Mode

SYNC	Communication Mode	Supported Protocols
0	Asynchronous	RS-232, RS-485 (w/external driver), IrDA, ISO 7816
1	Synchronous	SPI, MicroWire, 3-wire

[Table 20.2 USART Pin Usage on page 564](#) explains the functionality of the different USART pins when the USART operates in different modes. Pin functionality enclosed in square brackets is optional, and depends on additional configuration parameters. LOOPBK and MASTER are discussed in [20.3.2.14 Local Loopback](#) and [20.3.3.3 Synchronous Main Interface Mode](#) respectively.

Table 20.2. USART Pin Usage

SYNC	LOOPBK	MASTER	Pin functionality			
			U(S)n_TX (MOSI)	U(S)n_RX (MISO)	USn_CLK	USn_CS
0	0	x	Data out	Data in	-	[Driver enable]
0	1	x	Data out/in	-	-	[Driver enable]
1	0	0	Data in	Data out	Clock in	Secondary select
1	0	1	Data out	Data in	Clock out	[Auto secondary select]
1	1	0	Data out/in	-	Clock in	Secondary select
1	1	1	Data out/in	-	Clock out	[Auto secondary select]

20.3.2 Asynchronous Operation

20.3.2.1 Frame Format

The frame format used in asynchronous mode consists of a set of data bits in addition to bits for synchronization and optionally a parity bit for error checking. A frame starts with one start-bit (S), where the line is driven low for one bit-period. This signals the start of a frame, and is used for synchronization. Following the start bit are 4 to 16 data bits and an optional parity bit. Finally, a number of stop-bits, where the line is driven high, end the frame. An example frame is shown in [Figure 20.2 USART Asynchronous Frame Format on page 565](#).

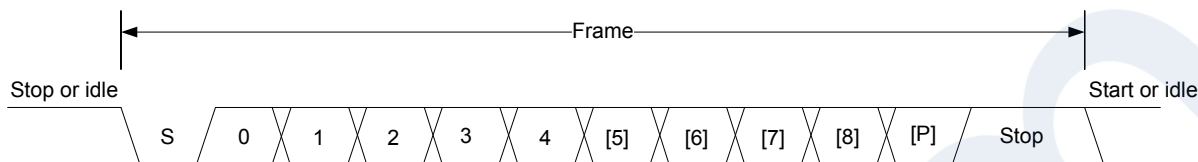

Figure 20.2. USART Asynchronous Frame Format

The number of data bits in a frame is set by `DATABITS` in `USARTn_FRAME`, see [Table 20.3 USART Data Bits on page 565](#), and the number of stop-bits is set by `STOPBITS` in `USARTn_FRAME`, see [Table 20.4 USART Stop Bits on page 565](#). Whether or not a parity bit should be included, and whether it should be even or odd is defined by `PARITY`, also in `USARTn_FRAME`. For communication to be possible, all parties of an asynchronous transfer must agree on the frame format being used.

Table 20.3. USART Data Bits

DATA BITS [3:0]	Number of Data bits
0001	4
0010	5
0011	6
0100	7
0101	8 (Default)
0110	9
0111	10
1000	11
1001	12
1010	13
1011	14
1100	15
1101	16

Table 20.4. USART Stop Bits

STOP BITS [1:0]	Number of Stop bits
00	0.5
01	1 (Default)
10	1.5
11	2

The order in which the data bits are transmitted and received is defined by MSBF in USARTn_CTRL. When MSBF is cleared, data in a frame is sent and received with the least significant bit first. When it is set, the most significant bit comes first.

The frame format used by the transmitter can be inverted by setting TXINV in USARTn_CTRL, and the format expected by the receiver can be inverted by setting RXINV in USARTn_CTRL. These bits affect the entire frame, not only the data bits. An inverted frame has a low idle state, a high start-bit, inverted data and parity bits, and low stop-bits.

20.3.2.2 Parity Bit Calculation and Handling

When parity bits are enabled, hardware automatically calculates and inserts any parity bits into outgoing frames, and verifies the received parity bits in incoming frames. This is true for both asynchronous and synchronous modes, even though it is mostly used in asynchronous communication. The possible parity modes are defined in [Table 20.5 USART Parity Bits on page 566](#). When even parity is chosen, a parity bit is inserted to make the number of high bits (data + parity) even. If odd parity is chosen, the parity bit makes the total number of high bits odd.

Table 20.5. USART Parity Bits

PARITY BITS [1:0]	Description
00	No parity bit (Default)
01	Reserved
10	Even parity
11	Odd parity

20.3.2.3 Clock Generation

The USART clock defines the transmission and reception data rate. When operating in asynchronous mode, the baud rate (bit-rate) is given by [Figure 20.3 USART Baud Rate on page 567](#).

$$br = f_{PCLK}/(\text{oversample} \times (1 + \text{USARTn_CLKDIV}/256))$$

Figure 20.3. USART Baud Rate

where f_{PCLK} is the peripheral clock ($PCLK_{\text{USARTn}}$) frequency and oversample is the oversampling rate as defined by OVS in USARTn_CTRL , see [Table 20.6 USART Oversampling on page 567](#).

Table 20.6. USART Oversampling

OVS [1:0]	oversample
00	16
01	8
10	6
11	4

The USART has a fractional clock divider to allow the USART clock to be controlled more accurately than what is possible with a standard integral divider.

The clock divider used in the USART is a 20-bit value, with a 15-bit integral part and an 5-bit fractional part. The fractional part is configured in the lower 5 bits of DIV in USART_CLKDIV . The lowest achievable baud rate at 32 MHz is about 61 bauds/sec.

Fractional clock division is implemented by distributing the selected fraction over four baud periods. The fractional part of the divider tells how many of these periods should be extended by one peripheral clock cycle.

Given a desired baud rate br_{desired} , the clock divider USARTn_CLKDIV can be calculated by using [Figure 20.4 USART Desired Baud Rate on page 567](#):

$$\text{USARTn_CLKDIV} = 256 \times (f_{PCLK}/(\text{oversample} \times br_{\text{desired}}) - 1)$$

Figure 20.4. USART Desired Baud Rate

[Table 20.7 USART Baud Rates @ 4MHz Peripheral Clock with 20 bit CLKDIV on page 567](#) shows a set of desired baud rates and how accurately the USART is able to generate these baud rates when running at a 4 MHz peripheral clock, using 16x or 8x oversampling.

Table 20.7. USART Baud Rates @ 4MHz Peripheral Clock with 20 bit CLKDIV

Desired baud rate [baud/s]	USARTn_OVS =00			USARTn_OVS =01		
	USARTn_CLKDIV/256 (to 32nd position)	Actual baud rate [baud/s]	Error %	USARTn_CLKDIV/256 (to 32nd position)	Actual baud rate [baud/s]	Error %
600	415,6563	600,015	0,003	832,3438	599,9925	-0,001
1200	207,3438	1199,94	-0,005	415,6563	1200,03	0,003
2400	103,1563	2400,24	0,010	207,3438	2399,88	-0,005
4800	51,09375	4799,04	-0,020	103,1563	4800,48	0,010
9600	25,03125	9603,842	0,040	51,09375	9598,08	-0,020
14400	16,375	14388,49	-0,080	33,71875	14401,44	0,010
19200	12,03125	19184,65	-0,080	25,03125	19207,68	0,040
28800	7,6875	28776,98	-0,080	16,375	28776,98	-0,080

Desired baud rate [baud/s]	USARTn_OVS =00			USARTn_OVS =01		
	USARTn_CLKDIV/256 (to 32nd position)	Actual baud rate [baud/s]	Error %	USARTn_CLKDIV/256 (to 32nd position)	Actual baud rate [baud/s]	Error %
38400	5,5	38461,54	0,160	12,03125	38369,3	-0,080
57600	3,34375	57553,96	-0,080	7,6875	57553,96	-0,080
76800	2,25	76923,08	0,160	5,5	76923,08	0,160
115200	1,15625	115942	0,644	3,34375	115107,9	-0,080
230400	0,09375	228571,4	-0,794	1,15625	231884,1	0,644

20.3.2.4 Auto Baud Detection

Setting AUTOBAUDEN in USARTn_CLKDIV uses the first frame received to automatically set the baud rate provided that it contains 0x55 (IrDA uses 0x00). AUTOBAUDEN can be used in a simple LIN configuration to auto detect the SYNC byte. The receiver will measure the number of local clock cycles between the beginning of the START bit and the beginning of the 8th data bit. The DIV field in USARTn_CLKDIV will be overwritten with the new value. The OVS in USARTn_CTRL and the +1 count of the Baud Rate equation are already factored into the result that gets written into the DIV field. To restart autobaud detection, clear AUTOBAUDEN and set it high again. Since the auto baud detection is done over 8 baud times, only the upper 3 bits of the fractional part of the clock divider are populated.

20.3.2.5 Data Transmission

Asynchronous data transmission is initiated by writing data to the transmit buffer using one of the methods described in [20.3.2.6 Transmit Buffer Operation](#). When the transmission shift register is empty and ready for new data, a frame from the transmit buffer is loaded into the shift register, and if the transmitter is enabled, transmission begins. When the frame has been transmitted, a new frame is loaded into the shift register if available, and transmission continues. If the transmit buffer is empty, the transmitter goes to an idle state, waiting for a new frame to become available.

Transmission is enabled through the command register USARTn_CMD by setting TXEN, and disabled by setting TXDIS in the same command register. When the transmitter is disabled using TXDIS, any ongoing transmission is aborted, and any frame currently being transmitted is discarded. When disabled, the TX output goes to an idle state, which by default is a high value. Whether or not the transmitter is enabled at a given time can be read from TXENS in USARTn_STATUS.

When the USART transmitter is enabled and there is no data in the transmit shift register or transmit buffer, the TXC flag in USARTn_STATUS and the TXC interrupt flag in USARTn_IF are set, signaling that the transmission is complete. The TXC status flag is cleared when a new frame becomes available for transmission, but the TXC interrupt flag must be cleared by software.

20.3.2.6 Transmit Buffer Operation

The transmit-buffer is a multiple entry FIFO buffer. A frame can be loaded into the buffer by writing to USARTn_TXDATA, USARTn_TXDATAx, USARTn_TXDOUBLE or USARTn_TXDOUBLEx. Using USARTn_TXDATA allows 8 bits to be written to the buffer, while using USARTn_TXDOUBLE will write 2 frames of 8 bits to the buffer. If 9-bit frames are used, the 9th bit of the frames will in these cases be set to the value of BIT8DV in USARTn_CTRL.

To set the 9th bit directly and/or use transmission control, USARTn_TXDATAx and USARTn_TXDOUBLEx must be used. USARTn_TXDATAx allows 9 data bits to be written, as well as a set of control bits regarding the transmission of the written frame. Every frame in the buffer is stored with 9 data bits and additional transmission control bits. USARTn_TXDOUBLEx allows two frames, complete with control bits to be written at once. When data is written to the transmit buffer using USARTn_TXDATAx and USARTn_TXDOUBLEx, the 9th bit(s) written to these registers override the value in BIT8DV in USARTn_CTRL, and alone define the 9th bits that are transmitted if 9-bit frames are used. [Figure 20.5 USART Transmit Buffer Operation on page 569](#) shows the basics of the transmit buffer when DATABITS in USARTn_FRAME is configured to less than 10 bits.

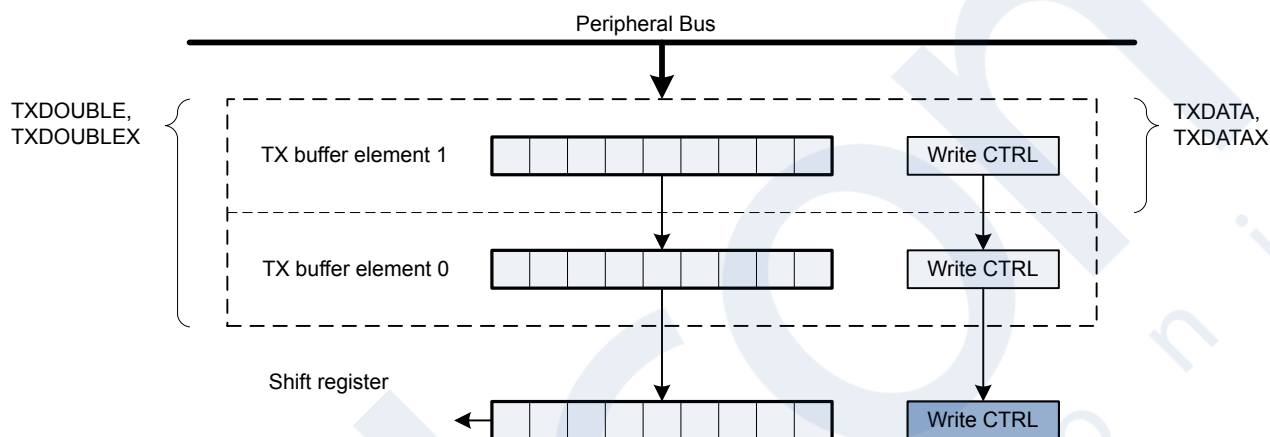

Figure 20.5. USART Transmit Buffer Operation

When writing more frames to the transmit buffer than there is free space for, the TXOF interrupt flag in USARTn_IF will be set, indicating the overflow. The data already in the transmit buffer is preserved in this case, and no data is written.

In addition to the interrupt flag TXC in USARTn_IF and status flag TXC in USARTn_STATUS which are set when the transmission is complete, TXBL in USARTn_STATUS and the TXBL interrupt flag in USARTn_IF are used to indicate the level of the transmit buffer. TXBIL in USARTn_CTRL controls the level at which these bits are set. If TXBIL is cleared, they are set whenever the transmit buffer becomes empty, and if TXBIL is set, they are set whenever the transmit buffer goes from full to half-full or empty. Both the TXBL status flag and the TXBL interrupt flag are cleared automatically when their condition becomes false.

The transmit buffer, including the transmit shift register can be cleared by setting CLEAR_TX in USARTn_CMD. This will prevent the USART from transmitting the data in the buffer and shift register, and will make them available for new data. Any frame currently being transmitted will not be aborted. Transmission of this frame will be completed.

20.3.2.7 Frame Transmission Control

The transmission control bits, which can be written using USARTn_TXDATAx and USARTn_TXDOUBLEx, affect the transmission of the written frame. The following options are available:

- **Generate break:** By setting TXBREAK, the output will be held low during the stop-bit period to generate a framing error. A receiver that supports break detection detects this state, allowing it to be used e.g. for framing of larger data packets. The line is driven high before the next frame is transmitted so the next start condition can be identified correctly by the recipient. Continuous breaks lasting longer than a USART frame are thus not supported by the USART. GPIO can be used for this.
- **Disable transmitter after transmission:** If TXDISAT is set, the transmitter is disabled after the frame has been fully transmitted.
- **Enable receiver after transmission:** If RXENAT is set, the receiver is enabled after the frame has been fully transmitted. It is enabled in time to detect a start-bit directly after the last stop-bit has been transmitted.
- **Unblock receiver after transmission:** If UBRXAT is set, the receiver is unblocked and RXBLOCK is cleared after the frame has been fully transmitted.
- **Tristate transmitter after transmission:** If TXTRIAT is set, TXTRI is set after the frame has been fully transmitted, tristating the transmitter output. Tristating of the output can also be performed automatically by setting AUTOTRI. If AUTOTRI is set TXTRI is always read as 0.

Note: When in SmartCard mode with repeat enabled, none of the actions, except generate break, will be performed until the frame is transmitted without failure. Generation of a break in SmartCard mode with repeat enabled will cause the USART to detect a NACK on every frame.

20.3.2.8 Data Reception

Data reception is enabled by setting RXEN in USARTn_CMD. When the receiver is enabled, it actively samples the input looking for a transition from high to low indicating the start baud of a new frame. When a start baud is found, reception of the new frame begins if the receive shift register is empty and ready for new data. When the frame has been received, it is pushed into the receive buffer, making the shift register ready for another frame of data, and the receiver starts looking for another start baud. If the receive buffer is full, the received frame remains in the shift register until more space in the receive buffer is available. If an incoming frame is detected while both the receive buffer and the receive shift register are full, the data in the shift register is overwritten, and the RXOF interrupt flag in USARTn_IF is set to indicate the buffer overflow.

The receiver can be disabled by setting the command bit RXDIS in USARTn_CMD. Any frame currently being received when the receiver is disabled is discarded. Whether or not the receiver is enabled at a given time can be read out from RXENS in USARTn_STATUS.

20.3.2.9 Receive Buffer Operation

When data becomes available in the receive buffer, the RXDATAV flag in USARTn_STATUS, and the RXDATAV interrupt flag in USARTn_IF are set, and when the buffer becomes full, RXFULL in USARTn_STATUS and the RXFULL interrupt flag in USARTn_IF are set. The status flags RXDATAV and RXFULL are automatically cleared by hardware when their condition is no longer true. This also goes for the RXDATAV interrupt flag, but the RXFULL interrupt flag must be cleared by software. When the RXFULL flag is set, notifying that the buffer is full, space is still available in the receive shift register for one more frame.

Data can be read from the receive buffer in a number of ways. USARTn_RXDATA gives access to the 8 least significant bits of the received frame, and USARTn_RXDOUBLE makes it possible to read the 8 least significant bits of two frames at once, pulling two frames from the buffer. To get access to the 9th, most significant bit, USARTn_RXDATA_X must be used. This register also contains status information regarding the frame. USARTn_RXDOUBLE_X can be used to get two frames complete with the 9th bits and status bits.

When a frame is read from the receive buffer using USARTn_RXDATA or USARTn_RXDATA_X, the frame is pulled out of the buffer, making room for a new frame. USARTn_RXDOUBLE and USARTn_RXDOUBLE_X pull two frames out of the buffer. If an attempt is done to read more frames from the buffer than what is available, the RXUF interrupt flag in USARTn_IF is set to signal the underflow, and the data read from the buffer is undefined.

Frames can be read from the receive buffer without removing the data by using USARTn_RXDATA_X_P and USARTn_RXDOUBLE_X_P. USARTn_RXDATA_X_P gives access the first frame in the buffer with status bits, while USARTn_RXDOUBLE_X_P gives access to both frames with status bits. The data read from these registers when the receive buffer is empty is undefined. If the receive buffer contains one valid frame, the first frame in USARTn_RXDOUBLE_X_P will be valid. No underflow interrupt is generated by a read using these registers, i.e. RXUF in USARTn_IF is never set as a result of reading from USARTn_RXDATA_X_P or USARTn_RXDOUBLE_X_P.

The basic operation of the receive buffer when DATABITS in USARTn_FRAME is configured to less than 10 bits is shown in [Figure 20.6 USART Receive Buffer Operation on page 571](#).

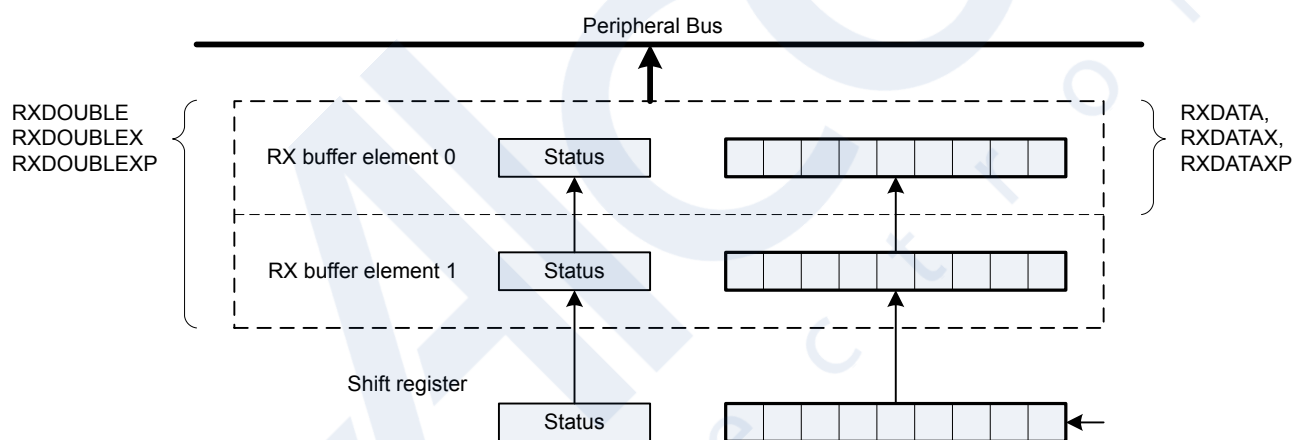

Figure 20.6. USART Receive Buffer Operation

The receive buffer, including the receive shift register can be cleared by setting CLEARRX in USARTn_CMD. Any frame currently being received will not be discarded.

20.3.2.10 Blocking Incoming Data

When using hardware frame recognition, as detailed in [20.3.2.20 Multi-Processor Mode](#) and [20.3.2.21 Collision Detection](#), it is necessary to be able to let the receiver sample incoming frames without passing the frames to software by loading them into the receive buffer. This is accomplished by blocking incoming data.

Incoming data is blocked as long as RXBLOCK in USARTn_STATUS is set. When blocked, frames received by the receiver will not be loaded into the receive buffer, and software is not notified by the RXDATAV flag in USARTn_STATUS or the RXDATAV interrupt flag in USARTn_IF at their arrival. For data to be loaded into the receive buffer, RXBLOCK must be cleared in the instant a frame is fully received by the receiver. RXBLOCK is set by setting RXBLOCKEN in USARTn_CMD and disabled by setting RXBLOCKDIS also in USARTn_CMD. There is one exception where data is loaded into the receive buffer even when RXBLOCK is set. This is when an address frame is received when operating in multi-processor mode. See [20.3.2.20 Multi-Processor Mode](#) for more information.

Frames received containing framing or parity errors will not result in the FERR and PERR interrupt flags in USARTn_IF being set while RXBLOCK in USARTn_STATUS is set. Hardware recognition is not applied to these erroneous frames, and they are silently discarded.

Note: If a frame is received while RXBLOCK in USARTn_STATUS is cleared, but stays in the receive shift register because the receive buffer is full, the received frame will be loaded into the receive buffer when space becomes available even if RXBLOCK is set at that time. The overflow interrupt flag RXOF in USARTn_IF will be set if a frame in the receive shift register, waiting to be loaded into the receive buffer is overwritten by an incoming frame even though RXBLOCK in USARTn_STATUS is set.

20.3.2.11 Clock Recovery and Filtering

The receiver samples the incoming signal at a rate 16, 8, 6 or 4 times higher than the given baud rate, depending on the oversampling mode given by OVS in USARTn_CTRL. Lower oversampling rates make higher baud rates possible, but give less room for errors.

When a high-to-low transition is registered on the input while the receiver is idle, this is recognized as a start-bit, and the baud rate generator is synchronized with the incoming frame.

For oversampling modes 16, 8 and 6, every bit in the incoming frame is sampled three times to gain a level of noise immunity. These samples are aimed at the middle of the bit-periods, as visualized in [Figure 20.7 USART Sampling of Start and Data Bits on page 573](#). With OVS=0 in USARTn_CTRL, the start and data bits are thus sampled at locations 8, 9 and 10 in the figure, locations 4, 5 and 6 for OVS=1 and locations 3, 4, and 5 for OVS=2. The value of a sampled bit is determined by majority vote. If two or more of the three bit-samples are high, the resulting bit value is high. If the majority is low, the resulting bit value is low.

Majority vote is used for all oversampling modes except 4x oversampling. In this mode, a single sample is taken at position 3 as shown in [Figure 20.7 USART Sampling of Start and Data Bits on page 573](#).

Majority vote can be disabled by setting MVDIS in USARTn_CTRL.

If the value of the start bit is found to be high, the reception of the frame is aborted, filtering out false start bits possibly generated by noise on the input.

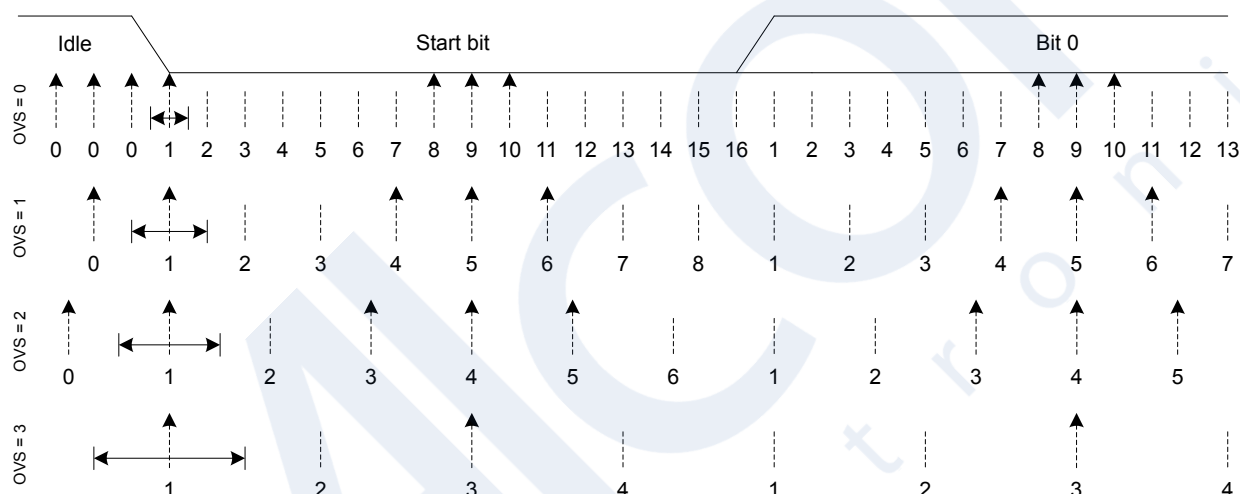

Figure 20.7. USART Sampling of Start and Data Bits

If the baud rate of the transmitter and receiver differ, the location each bit is sampled will be shifted towards the previous or next bit in the frame. This is acceptable for small errors in the baud rate, but for larger errors, it will result in transmission errors.

When the number of stop bits is 1 or more, stop bits are sampled like the start and data bits as seen in [Figure 20.8 USART Sampling of Stop Bits when Number of Stop Bits are 1 or More on page 574](#). When a stop bit has been detected by sampling at positions 8, 9 and 10 for normal mode, or 4, 5 and 6 for smart mode, the USART is ready for a new start bit. As seen in [Figure 20.8 USART Sampling of Stop Bits when Number of Stop Bits are 1 or More on page 574](#), a stop-bit of length 1 normally ends at c, but the next frame will be received correctly as long as the start-bit comes after position a for OVS=0 and OVS=3, and b for OVS=1 and OVS=2.

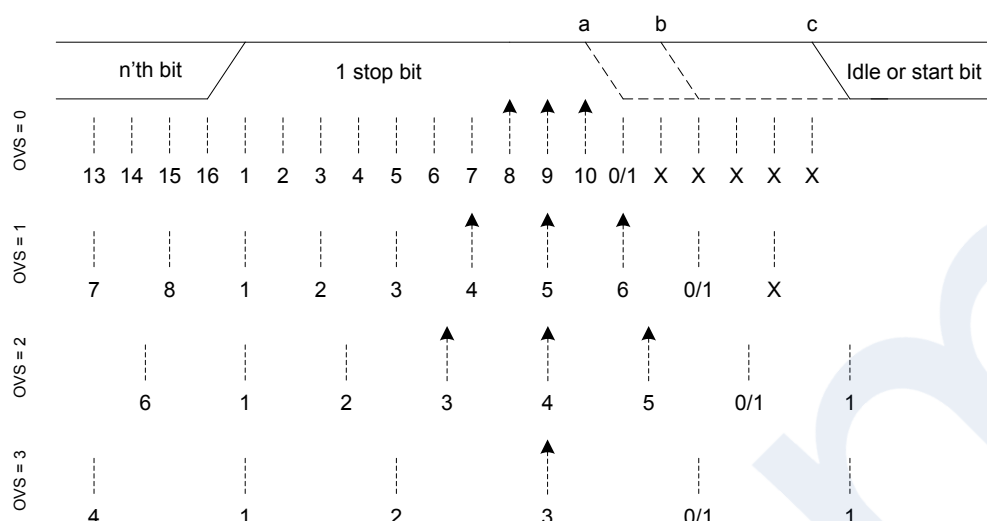

Figure 20.8. USART Sampling of Stop Bits when Number of Stop Bits are 1 or More

When working with stop bit lengths of half a baud period, the above sampling scheme no longer suffices. In this case, the stop-bit is not sampled, and no framing error is generated in the receiver if the stop-bit is not generated. The line must still be driven high before the next start bit however for the USART to successfully identify the start bit.

20.3.2.12 Parity Error

When parity bits are enabled, a parity check is automatically performed on incoming frames. When a parity error is detected in an incoming frame, the data parity error bit PERR in the frame is set, as well as the interrupt flag PERR in USARTn_IF. Frames with parity errors are loaded into the receive buffer like regular frames.

PERR can be accessed by reading the frame from the receive buffer using the USARTn_RXDATAx, USARTn_RXDATAxP, USARTn_RXDOUBLEX or USARTn_RXDOUBLEXP registers.

If ERRSTX in USARTn_CTRL is set, the transmitter is disabled on received parity and framing errors. If ERRSRX in USARTn_CTRL is set, the receiver is disabled on parity and framing errors.

20.3.2.13 Framing Error and Break Detection

A framing error is the result of an asynchronous frame where the stop bit was sampled to a value of 0. This can be the result of noise and baud rate errors, but can also be the result of a break generated by the transmitter on purpose.

When a framing error is detected in an incoming frame, the framing error bit FERR in the frame is set. The interrupt flag FERR in USARTn_IF is also set. Frames with framing errors are loaded into the receive buffer like regular frames.

FERR can be accessed by reading the frame from the receive buffer using the USARTn_RXDATAx, USARTn_RXDATAxP, USARTn_RXDOUBLEX or USARTn_RXDOUBLEXP registers.

If ERRSTX in USARTn_CTRL is set, the transmitter is disabled on parity and framing errors. If ERRSRX in USARTn_CTRL is set, the receiver is disabled on parity and framing errors.

20.3.2.14 Local Loopback

The USART receiver samples U(S)n_RX by default, and the transmitter drives U(S)n_TX by default. This is not the only option however. When LOOPBK in USARTn_CTRL is set, the receiver is connected to the U(S)n_TX pin as shown in [Figure 20.9 USART Local Loopback on page 575](#). This is useful for debugging, as the USART can receive the data it transmits, but it is also used to allow the USART to read and write to the same pin, which is required for some half duplex communication modes. In this mode, the U(S)n_TX pin must be enabled as an output in the GPIO.

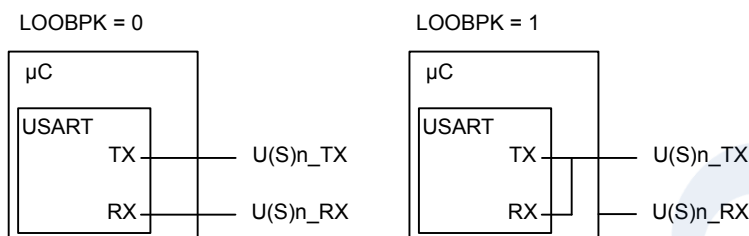

Figure 20.9. USART Local Loopback

20.3.2.15 Asynchronous Half Duplex Communication

When doing full duplex communication, two data links are provided, making it possible for data to be sent and received at the same time. In half duplex mode, data is only sent in one direction at a time. There are several possible half duplex setups, as described in the following sections.

20.3.2.16 Single Data-link

In this setup, the USART both receives and transmits data on the same pin. This is enabled by setting LOOPBK in USARTn_CTRL, which connects the receiver to the transmitter output. Because they are both connected to the same line, it is important that the USART transmitter does not drive the line when receiving data, as this would corrupt the data on the line.

When communicating over a single data-link, the transmitter must thus be tristated whenever not transmitting data. This is done by setting the command bit TXTRIEN in USARTn_CMD, which tristates the transmitter. Before transmitting data, the command bit TXTRIDIS, also in USARTn_CMD, must be set to enable transmitter output again. Whether or not the output is tristated at a given time can be read from TXTRI in USARTn_STATUS. If TXTRI is set when transmitting data, the data is shifted out of the shift register, but is not put out on U(S)n_TX.

When operating a half duplex data bus, it is common to have a main bus controller, which first transmits a request to one of the secondary devices on the bus, then receives a reply. In this case, the frame transmission control bits, which can be set by writing to USARTn_TXDATAx, can be used to make the USART automatically disable transmission, tristate the transmitter and enable reception when the request has been transmitted, making it ready to receive a response from the secondary device.

The timer, [20.3.10 Timer](#), can also be used to add delay between the RX and TX frames so that the interrupt service routine has time to process data that was just received before transmitting more data. Also hardware flow control is another method to insert time for processing the frame. RTS and CTS can be used to halt either the link partner's transmitter or the local transmitter. See the section on hardware flow control, [20.3.4 Hardware Flow Control](#), for more details.

Tristating the transmitter can also be performed automatically by the USART by using AUTOTRI in USARTn_CTRL. When AUTOTRI is set, the USART automatically tristates U(S)n_TX whenever the transmitter is idle, and enables transmitter output when the transmitter goes active. If AUTOTRI is set TXTRI is always read as 0.

Note: Another way to tristate the transmitter is to enable wired-and or wired-or mode in GPIO. For wired-and mode, outputting a 1 will be the same as tristating the output, and for wired-or mode, outputting a 0 will be the same as tristating the output. This can only be done on buses with a pull-up or pull-down resistor respectively.

20.3.2.17 Single Data-link with External Driver

Some communication schemes, such as RS-485 rely on an external driver. Here, the driver has an extra input which enables it, and instead of tristating the transmitter when receiving data, the external driver must be disabled.

This can be done manually by assigning a GPIO to turn the driver on or off, or it can be handled automatically by the USART. If AUTOCS in USARTn_CTRL is set, the USn_CS output is automatically activated a configurable number of baud periods before the transmitter starts transmitting data, and deactivated a configurable number of baud periods after the last bit has been transmitted and there is no more data in the transmit buffer to transmit. The number of baud periods are controlled by CSSETUP and CSHOLD in USARTn_TIMING. This feature can be used to turn the external driver on when transmitting data, and turn it off when the data has been transmitted.

The timer, [20.3.10 Timer](#), can also be used to configure CSSETUP and CSHOLD values between 1 to 256 baud-times by using TCMPVAL0, TCMPVAL1, or TCMPVAL2 for the TX sequencer.

USn_CS is immediately deasserted when the transmitter becomes disabled.

Note: When using CSSETUP in asynchronous mode with AUTOCS (USARTn_CTRL.SYNC = 0, USARTn_CTRL.AUTOCS = 1), TXDELAY in USARTn_TIMING should be set to 1.

[Figure 20.10 USART Half Duplex Communication with External Driver on page 576](#) shows an example configuration where USn_CS is used to automatically enable and disable an external driver.

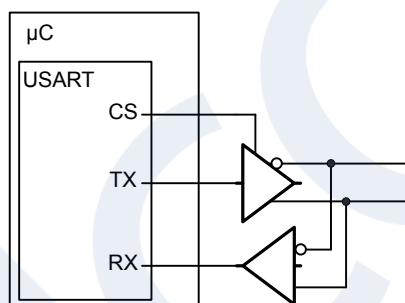

Figure 20.10. USART Half Duplex Communication with External Driver

The USn_CS output is active low by default, but its polarity can be changed with CSINV in USARTn_CTRL. AUTOCS works regardless of which mode the USART is in, so this functionality can also be used for automatic chip select when in synchronous mode (e.g. SPI).

20.3.2.18 Two Data-links

Some limited devices only support half duplex communication even though two data links are available. In this case software is responsible for making sure data is not transmitted when incoming data is expected.

TXARXnEN in USARTn_TRIGCTRL may be used to automatically start transmission after the end of the RX frame plus any TXSTDELAY and CSSETUP delay in USARTn_TIMING. For enabling the receiver either use RXENAT in USARTn_TXDATAx or RXATXnEN in USARTn_TRIGCTRL.

20.3.2.19 Large Frames

As each frame in the transmit and receive buffers holds a maximum of 9 bits, both the elements in the buffers are combined when working with USART-frames of 10 or more data bits.

To transmit such a frame, at least two elements must be available in the transmit buffer. If only one element is available, the USART will wait for the second element before transmitting the combined frame. Both the elements making up the frame are consumed when transmitting such a frame.

When using large frames, the 9th bits in the buffers are unused. For an 11 bit frame, the 8 least significant bits are thus taken from the first element in the buffer, and the 3 remaining bits are taken from the second element as shown in [Figure 20.11 USART Transmission of Large Frames on page 577](#). The first element in the transmit buffer, i.e. element 0 in [Figure 20.11 USART Transmission of Large Frames on page 577](#) is the first element written to the FIFO, or the least significant byte when writing two bytes at a time using USARTn_TXDOUBLE.

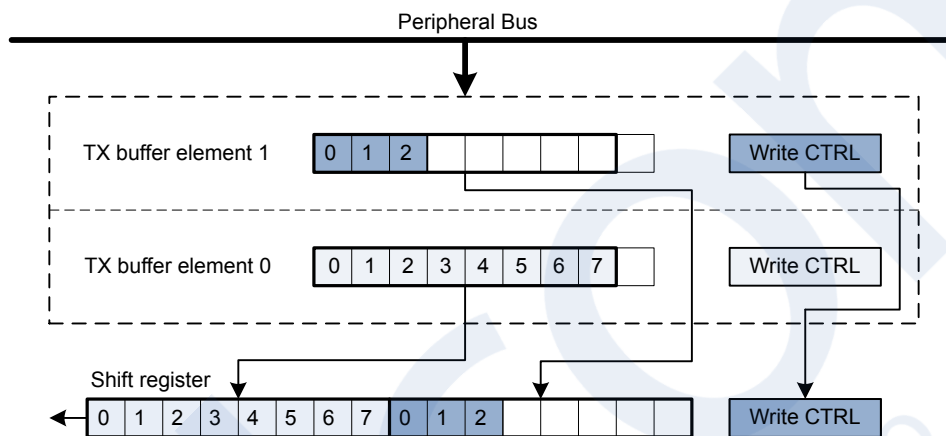

Figure 20.11. USART Transmission of Large Frames

As shown in [Figure 20.11 USART Transmission of Large Frames on page 577](#), frame transmission control bits are taken from the second element in FIFO.

The two buffer elements can be written at the same time using the USARTn_TXDOUBLE or USARTn_TXDOUBLEX register. The TXDATA0 bitfield then refers to buffer element 0, and TXDATA1 refers to buffer element 1.

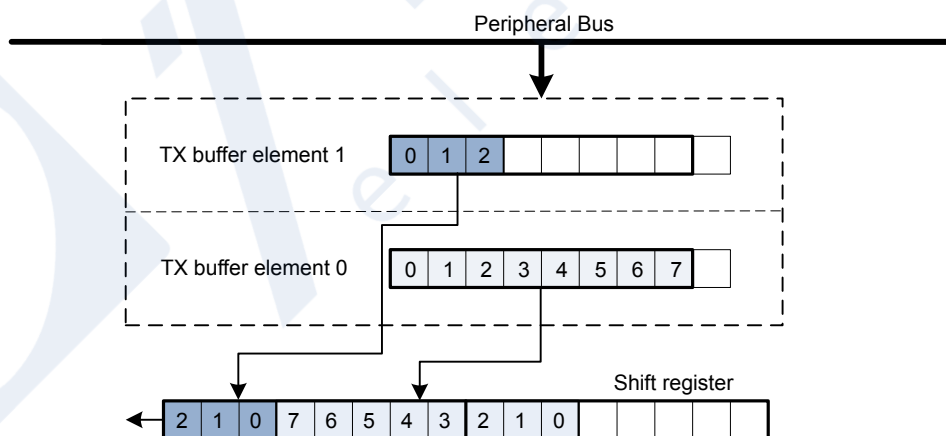

Figure 20.12. USART Transmission of Large Frames, MSBF

[Figure 20.12 USART Transmission of Large Frames, MSBF on page 577](#) illustrates the order of the transmitted bits when an 11 bit frame is transmitted with MSBF set. If MSBF is set and the frame is smaller than 10 bits, only the contents of transmit buffer 0 will be transmitted.

When receiving a large frame, `BYTESWAP` in `USARTn_CTRL` determines the order the way the large frame is split into the two buffer elements. If `BYTESWAP` is cleared, the least significant 8 bits of the received frame are loaded into the first element of the receive buffer, and the remaining bits are loaded into the second element, as shown in [Figure 20.13 USART Reception of Large Frames on page 578](#). The first byte read from the buffer thus contains the 8 least significant bits. Set `BYTESWAP` to reverse the order.

The status bits are loaded into both elements of the receive buffer. The frame is not moved from the receive shift register before there are two free spaces in the receive buffer.

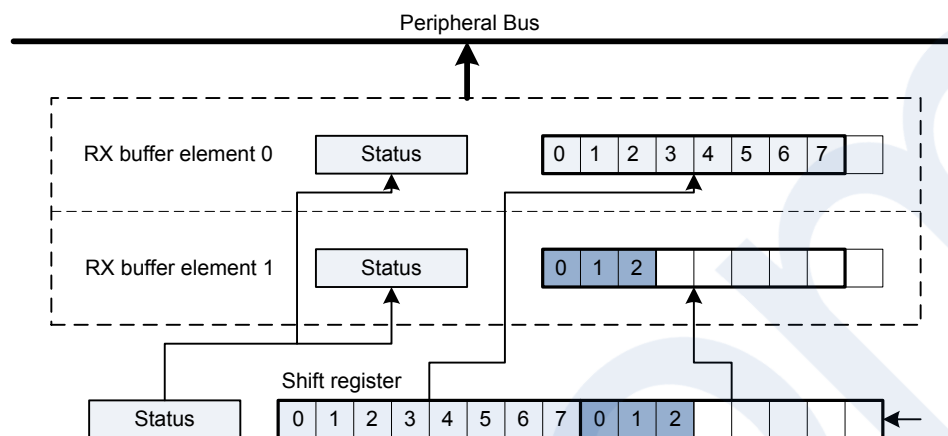

Figure 20.13. USART Reception of Large Frames

The two buffer elements can be read at the same time using the `USARTn_RXDOUBLE` or `USARTn_RXDOUBLEX` register. `RXDATA0` then refers to buffer element 0 and `RXDATA1` refers to buffer element 1.

Large frames can be used in both asynchronous and synchronous modes.

20.3.2.20 Multi-Processor Mode

To simplify communication between multiple processors, the USART supports a special multi-processor mode. In this mode the 9th data bit in each frame is used to indicate whether the content of the remaining 8 bits is data or an address.

When multi-processor mode is enabled, an incoming 9-bit frame with the 9th bit equal to the value of `MPAB` in `USARTn_CTRL` is identified as an address frame. When an address frame is detected, the `MPAF` interrupt flag in `USARTn_IF` is set, and the address frame is loaded into the receive register. This happens regardless of the value of `RXBLOCK` in `USARTn_STATUS`.

Multi-processor mode is enabled by setting `MPM` in `USARTn_CTRL`, and the value of the 9th bit in address frames can be set in `MPAB`. Note that the receiver must be enabled for address frames to be detected. The receiver can be blocked however, preventing data from being loaded into the receive buffer while looking for address frames.

When a device has received an address frame and wants to receive the following data, it must make sure the receiver is unblocked before the next frame has been completely received in order to prevent data loss.

`BIT8DV` in `USARTn_CTRL` can be used to specify the value of the 9th bit without writing to the transmit buffer with `USARTn_TXDATAx` or `USARTn_TXDOUBLEx`, giving higher efficiency in multi-processor mode, as the 9th bit is only set when writing address frames, and 8-bit writes to the USART can be used when writing the data frames.

20.3.2.21 Collision Detection

The USART supports a basic form of collision detection. When the receiver is connected to the output of the transmitter, either by using the `LOOPBK` bit in `USARTn_CTRL` or through an external connection, this feature can be used to detect whether data transmitted on the bus by the USART did get corrupted by a simultaneous transmission by another device on the bus.

For collision detection to be enabled, `CCEN` in `USARTn_CTRL` must be set, and the receiver enabled. The data sampled by the receiver is then continuously compared with the data output by the transmitter. If they differ, the `CCF` interrupt flag in `USARTn_IF` is set. The collision check includes all bits of the transmitted frames. The `CCF` interrupt flag is set once for each bit sampled by the receiver that differs from the bit output by the transmitter. When the transmitter output is disabled, i.e. the transmitter is tristated, collisions are not registered.

20.3.2.22 SmartCard Mode

In SmartCard mode, the USART supports the ISO 7816 I/O line T0 mode. With exception of the stop-bits (guard time), the 7816 data frame is equal to the regular asynchronous frame. In this mode, the receiver pulls the line low for one baud, half a baud into the guard time to indicate a parity error. This NAK can for instance be used by the transmitter to re-transmit the frame. SmartCard mode is a half duplex asynchronous mode, so the transmitter must be tristated whenever not transmitting data.

To enable SmartCard mode, set SCMODE in USARTn_CTRL, set the number of databits in a frame to 8, and configure the number of stopbits to 1.5 by writing to STOPBITS in USARTn_FRAME.

The SmartCard mode relies on half duplex communication on a single line, so for it to work, both the receiver and transmitter must work on the same line. This can be achieved by setting LOOPBK in USARTn_CTRL or through an external connection. The TX output should be configured as open-drain in the GPIO module.

When no parity error is identified by the receiver, the data frame is as shown in [Figure 20.14 USART ISO 7816 Data Frame Without Error on page 579](#). The frame consists of 8 data bits, a parity bit, and 2 stop bits. The transmitter does not drive the output line during the guard time.

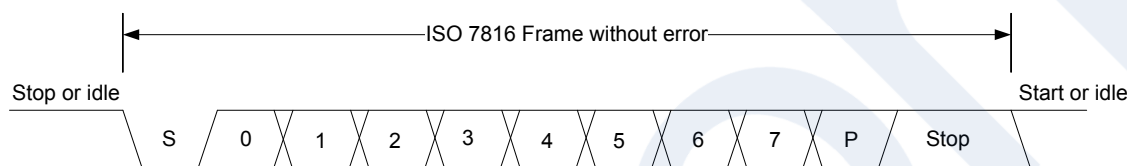

Figure 20.14. USART ISO 7816 Data Frame Without Error

If a parity error is detected by the receiver, it pulls the line I/O line low after half a stop bit, see [Figure 20.15 USART ISO 7816 Data Frame With Error on page 579](#). It holds the line low for one bit-period before it releases the line. In this case, the guard time is extended by one bit period before a new transmission can start, resulting in a total of 3 stop bits.

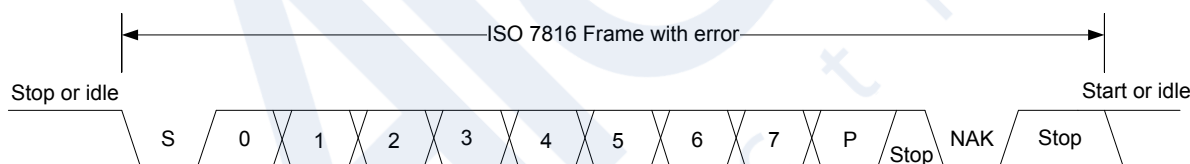

Figure 20.15. USART ISO 7816 Data Frame With Error

On a parity error, the NAK is generated by hardware. The NAK generated by the receiver is sampled as the stop-bit of the frame. Because of this, parity errors when in SmartCard mode are reported with both a parity error and a framing error.

When transmitting a T0 frame, the USART receiver on the transmitting side samples position 16, 17 and 18 in the stop-bit to detect the error signal when in 16x oversampling mode as shown in [Figure 20.16 USART SmartCard Stop Bit Sampling on page 580](#). Sampling at this location places the stop-bit sample in the middle of the bit-period used for the error signal (NAK).

If a NAK is transmitted by the receiver, it will thus appear as a framing error at the transmitter, and the FERR interrupt flag in USARTn_IF will be set. If SCRETRANS USARTn_CTRL is set, the transmitter will automatically retransmit a NACK'ed frame. The transmitter will retransmit the frame until it is ACK'ed by the receiver. This only works when the number of databits in a frame is configured to 8.

Set SKIPPERRF in USARTn_CTRL to make the receiver discard frames with parity errors. The PERR interrupt flag in USARTn_IF is set when a frame is discarded because of a parity error.

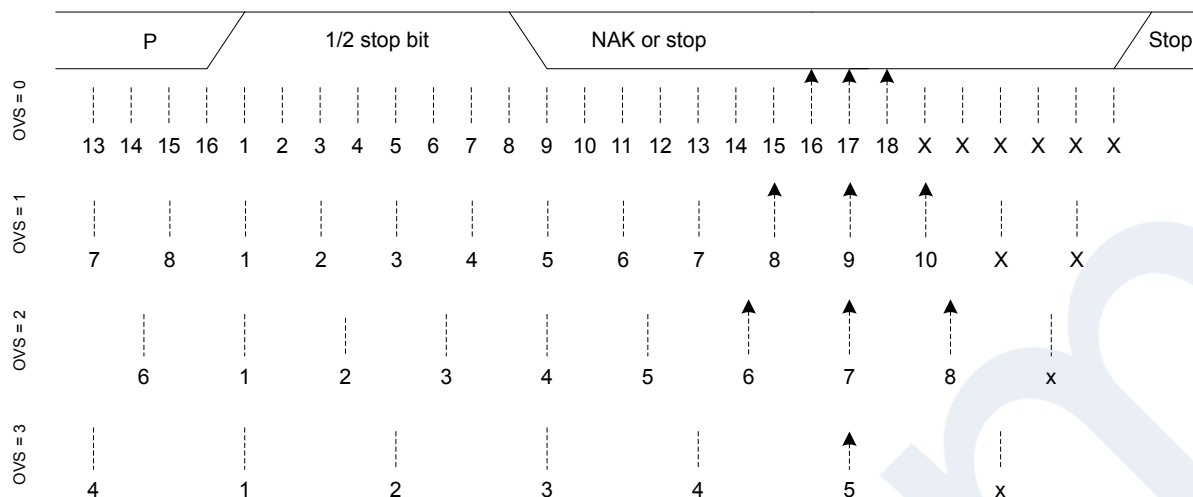

Figure 20.16. USART SmartCard Stop Bit Sampling

For communication with a SmartCard, a clock signal needs to be generated for the card. This clock output can be generated using one of the timers. See the ISO 7816 specification for more info on this clock signal.

SmartCard T1 mode is also supported. The T1 frame format used is the same as the asynchronous frame format with parity bit enabled and one stop bit. The USART must then be configured to operate in asynchronous half duplex mode.

20.3.3 Synchronous Operation

Most of the features in asynchronous mode are available in synchronous mode. Multi-processor mode can be enabled for 9-bit frames, loopback is available and collision detection can be performed.

20.3.3.1 Frame Format

The frames used in synchronous mode need no start and stop bits since a single clock is available to all parts participating in the communication. Parity bits cannot be used in synchronous mode.

The USART supports frame lengths of 4 to 16 bits per frame. Larger frames can be simulated by transmitting multiple smaller frames, i.e. a 22 bit frame can be sent using two 11-bit frames, and a 21 bit frame can be generated by transmitting three 7-bit frames. The number of bits in a frame is set using DATABITS in USARTn_FRAME.

The frames in synchronous mode are by default transmitted with the least significant bit first like in asynchronous mode. The bit-order can be reversed by setting MSBF in USARTn_CTRL.

The frame format used by the transmitter can be inverted by setting TXINV in USARTn_CTRL, and the format expected by the receiver can be inverted by setting RXINV, also in USARTn_CTRL.

20.3.3.2 Clock Generation

The bit-rate in synchronous mode is given by [Figure 20.17 USART Synchronous Mode Bit Rate on page 581](#). As in the case of asynchronous operation, the clock division factor have a 15-bit integral part and a 5-bit fractional part.

$$br = f_{PCLK}/(2 \times (1 + USARTn_CLKDIV/256))$$

Figure 20.17. USART Synchronous Mode Bit Rate

Given a desired baud rate $br_{desired}$, the clock divider $USARTn_CLKDIV$ can be calculated using [Figure 20.18 USART Synchronous Mode Clock Division Factor on page 581](#)

$$USARTn_CLKDIV = 256 \times (f_{PCLK}/(2 \times br_{desired}) - 1)$$

Figure 20.18. USART Synchronous Mode Clock Division Factor

When the USART operates as a synchronous main interface, the highest possible bit rate is half the peripheral clock rate. When operating as a secondary interface however, the highest bit rate is one sixth of the peripheral clock:

- Main interface mode: $br_{max} = f_{PCLK}/2$
- Secondary interface mode: $br_{max} = f_{PCLK}/6$

On every clock edge data on the data lines, MOSI and MISO, is either set up or sampled. When $CLKPHA$ in $USARTn_CTRL$ is cleared, data is sampled on the leading clock edge and set-up is done on the trailing edge. If $CLKPHA$ is set however, data is set-up on the leading clock edge, and sampled on the trailing edge. In addition to this, the polarity of the clock signal can be changed by setting $CLKPOL$ in $USARTn_CTRL$, which also defines the idle state of the clock. This results in four different modes which are summarized in [Table 20.8 USART SPI Modes on page 581](#). [Figure 20.19 USART SPI Timing on page 581](#) shows the resulting timing of data set-up and sampling relative to the bus clock.

Table 20.8. USART SPI Modes

SPI mode	CLKPOL	CLKPHA	Leading edge	Trailing edge
0	0	0	Rising, sample	Falling, set-up
1	0	1	Rising, set-up	Falling, sample
2	1	0	Falling, sample	Rising, set-up
3	1	1	Falling, set-up	Rising, sample

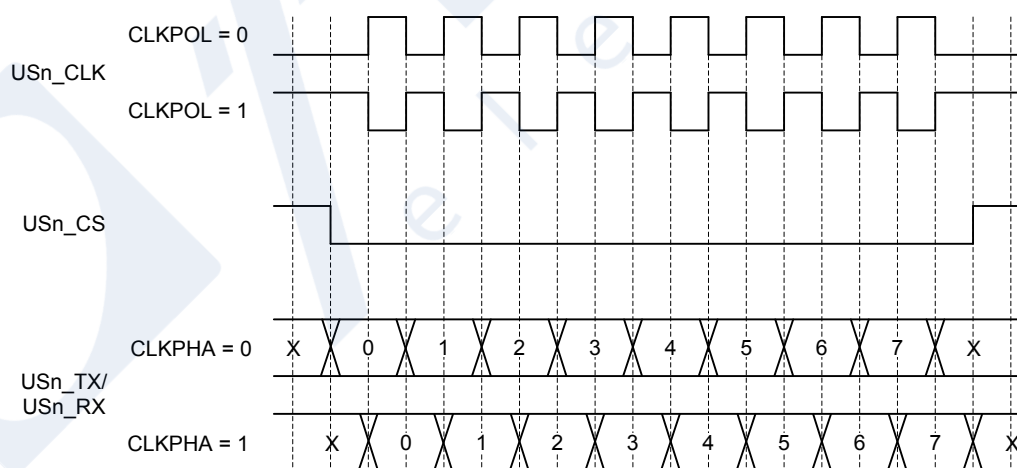

Figure 20.19. USART SPI Timing

If $CPHA=1$, the TX underflow flag, $TXUF$, will be set on the first setup clock edge of a frame in secondary mode if TX data is not available. If $CPHA=0$, $TXUF$ is set if data is not available in the transmit buffer three PCLK cycles prior to the first sample clock edge. The $RXDATAV$ flag is updated on the last sample clock edge of a transfer, while the RX overflow interrupt flag, $RXOF$, is set on the first

sample clock edge if the receive buffer overflows. When a transfer has been performed, interrupt flags TXBL and TXC are updated on the first setup clock edge of the succeeding frame, or when CS is deasserted.

20.3.3.3 Synchronous Main Interface Mode

When configured as a main interface, the USART is in full control of the data flow on the synchronous bus. When operating in full duplex mode, the secondary devices cannot transmit data to the main device without the main device transmitting to the secondary. The main device outputs the bus clock on USn_CLK.

Communication starts whenever there is data in the transmit buffer and the transmitter is enabled. The USART clock then starts, and the main device shifts bits out from the transmit shift register using the internal clock.

When there are no more frames in the transmit buffer and the transmit shift register is empty, the clock stops, and communication ends. When the receiver is enabled, it samples data using the internal clock when the transmitter transmits data. Operation of the RX and TX buffers is as in asynchronous mode.

20.3.3.4 Operation of USn_CS Pin

When operating as a synchronous main interface, the USn_CS pin can have one of two functions, or it can be disabled.

If USn_CS is configured as an output, it can be used to automatically generate a chip select for a secondary device by setting AUTOCS in USARTn_CTRL. If AUTOCS is set, USn_CS is activated before a transmission begins, and deactivated after the last bit has been transmitted and there is no more data in the transmit buffer.

The time between when CS is asserted and the first bit is transmitted can be controlled using the USART Timer and with CSSETUP in USARTn_TIMING. Any of the three comparators can be used to set this delay. If new data is ready for transmission before CS is deasserted, the data is sent without deasserting CS in between. CSHOLD in USARTn_TIMING keeps CS asserted after the end of frame for the number of baud-times specified.

By default, USn_CS is active low, but its polarity can be inverted by setting CSINV in USARTn_CTRL.

When USn_CS is configured as an input, it can be used by another synchronous main device that wants control of the bus to make the USART release it. When USn_CS is driven low, or high if CSINV is set, the interrupt flag SSM in USARTn_IF is set, and if CSMA in USARTn_CTRL is set, the USART goes to secondary mode.

20.3.3.5 AUTOTX

The main device on a synchronous bus is required to transmit data to a secondary device in order to receive data from that device. In some cases, only a few words are transmitted and a lot of data is then received from the secondary device. In that case, one solution is to keep feeding the TX with data to transmit, but that consumes system bandwidth. Instead AUTOTX can be used.

When AUTOTX in USARTn_CTRL is set, the USART transmits data as long as there is available space in the RX shift register for the chosen frame size. This happens even though there is no data in the TX buffer. The TX underflow interrupt flag TXUF in USARTn_IF is set on the first word that is transmitted which does not contain valid data.

During AUTOTX the USART will always send the previous sent bit, thus reducing the number of transitions on the TX output. So if the last bit sent was a 0, 0's will be sent during AUTOTX and if the last bit sent was a 1, 1's will be sent during AUTOTX.

20.3.3.6 Synchronous Secondary Interface Mode

When the USART is in synchronous secondary interface mode, data transmission is not controlled by the USART, but by an external synchronous main device. The USART is therefore not able to initiate a transmission, and has no control over the number of bytes written to the external main device.

The output and input to the USART are also swapped when in secondary mode, making the receiver take its input from USn_TX (MOSI) and the transmitter drive USn_RX (MISO).

To transmit data when in secondary mode, the device must load data into the transmit buffer and enable the transmitter. The data will remain in the USART until the main device starts a transmission by pulling the USn_CS input low and transmitting data. For every frame transmitted from main to secondary device, a frame is transferred from secondary to main as well. After a transmission, MISO remains in the same state as the last bit transmitted. This also applies if the main transmits to the secondary and the secondary TX buffer is empty.

If the transmitter is enabled in secondary synchronous mode and the main device starts transmission of a frame, the underflow interrupt flag TXUF in USARTn_IF will be set if no data is available for transmission.

If the secondary device needs to control its own chip select signal, this can be achieved by clearing CSPEN in the GPIO_USARTn_ROUTEEN register. The internal chip select signal can then be controlled through CSINV in the CTRL register. The chip select signal will be CSINV inverted, i.e. if CSINV is cleared, the chip select is active and vice versa.

20.3.3.7 Synchronous Half Duplex Communication

Half duplex communication in synchronous mode is very similar to half duplex communication in asynchronous mode as detailed in [20.3.2.15 Asynchronous Half Duplex Communication](#). The main difference is that in this mode, the main interface must generate the bus clock even when it is not transmitting data, i.e. it must provide the secondary device with a clock to receive data. To generate the bus clock, the main device should transmit data with the transmitter tristated, i.e. TXTRI in USARTn_STATUS set, when receiving data. If 2 bytes are expected from the secondary device, then transmit 2 bytes with the transmitter tristated, and the secondary uses the generated bus clock to transmit data to the main. TXTRI can be set by setting the TXTRIEN command bit in USARTn_CMD.

Note: When operating as SPI secondary interface in half duplex mode, TX has to be tristated (not disabled) during data reception if the device is to transmit data in the current transfer.

20.3.3.8 I2S

I2S is a synchronous format for transmission of audio data. The frame format is 32-bit, but since data is always transmitted with MSB first, an I2S device operating with 16-bit audio may choose to only process the 16 msb of the frame, and only transmit data in the 16 msb of the frame.

In addition to the bit clock used for regular synchronous transfers, I2S mode uses a separate word clock. When operating in mono mode, with only one channel of data, the word clock pulses once at the start of each new word. In stereo mode, the word clock toggles at the start of new words, and also gives away whether the transmitted word is for the left or right audio channel; A word transmitted while the word clock is low is for the left channel, and a word transmitted while the word clock is high is for the right.

When operating in I2S mode, the CS pin is used as a the word clock. In main mode, this is automatically driven by the USART, and in secondary mode, the word clock is expected from an external main device.

20.3.3.9 Word Format

The general I2S word format is 32 bits wide, but the USART also supports 16-bit and 8-bit words. In addition to this, it can be specified how many bits of the word should actually be used by the USART. These parameters are given by FORMAT in USARTn_I2SCTRL.

As an example, configuring FORMAT to using a 32-bit word with 16-bit data will make each word on the I2S bus 32-bits wide, but when receiving data through the USART, only the 16 most significant bits of each word can be read out of the USART. Similarly, only the 16 most significant bits have to be written to the USART when transmitting. The rest of the bits will be transmitted as zeroes.

20.3.3.10 Major Modes

The USART supports a set of different I2S formats as shown in [Table 20.9 USART I2S Modes on page 584](#), but it is not limited to these modes. MONO, JUSTIFY and DELAY in USARTn_I2SCTRL can be mixed and matched to create an appropriate format. MONO enables mono mode, i.e. one data stream instead of two which is the default. JUSTIFY aligns data within a word on the I2S bus, either left or right which can be seen in figures [Figure 20.22 USART Left-Justified I2S Waveform on page 585](#) and [Figure 20.23 USART Right-Justified I2S Waveform on page 585](#). Finally, DELAY specifies whether a new I2S word should be started directly on the edge of the word-select signal, or one bit-period after the edge.

Table 20.9. USART I2S Modes

Mode	MONO	JUSTIFY	DELAY	CLKPOL
Regular I2S	0	0	1	0
Left-Justified	0	0	0	1
Right-Justified	0	1	0	1
Mono	1	0	0	0

The regular I2S waveform is shown in [Figure 20.20 USART Standard I2S Waveform on page 584](#) and [Figure 20.21 USART Standard I2S Waveform \(Reduced Accuracy\) on page 584](#). The first figure shows a waveform transmitted with full accuracy. The wordlength can be configured to 32-bit, 16-bit or 8-bit using FORMAT in USARTn_I2SCTRL. In the second figure, I2S data is transmitted with reduced accuracy, i.e. the data transmitted has less bits than what is possible in the bus format.

Note that the msb of a word transmitted in regular I2S mode is delayed by one cycle with respect to word select

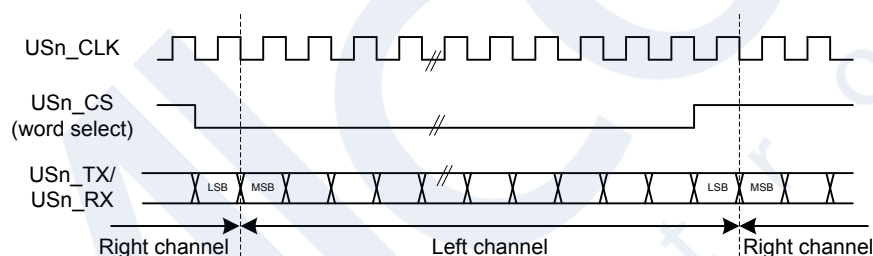

Figure 20.20. USART Standard I2S Waveform

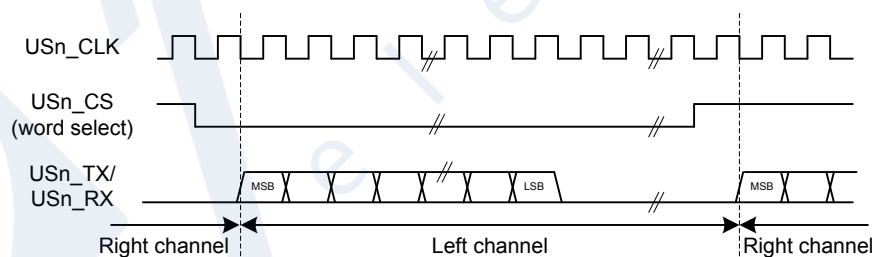

Figure 20.21. USART Standard I2S Waveform (Reduced Accuracy)

A left-justified stream is shown in [Figure 20.22 USART Left-Justified I2S Waveform on page 585](#). Note that the MSB comes directly after the edge on the word-select signal in contradiction to the regular I2S waveform where it comes one bit-period after.

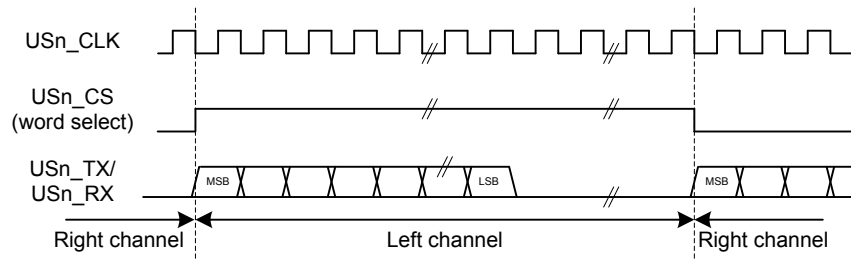

Figure 20.22. USART Left-Justified I2S Waveform

A right-justified stream is shown in [Figure 20.23 USART Right-Justified I2S Waveform on page 585](#). The left and right justified streams are equal when the data-size is equal to the word-width.

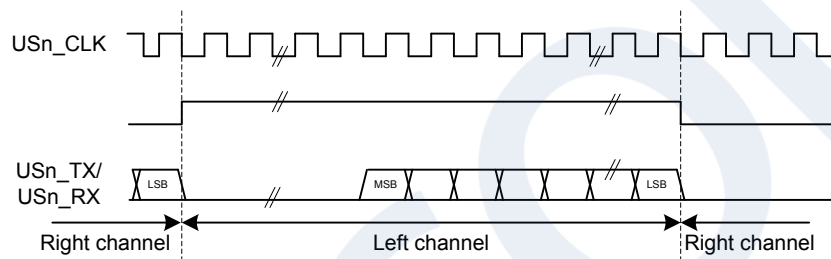

Figure 20.23. USART Right-Justified I2S Waveform

In mono-mode, the word-select signal pulses at the beginning of each word instead of toggling for each word. Mono I2S waveform is shown in [Figure 20.24 USART Mono I2S Waveform on page 585](#).

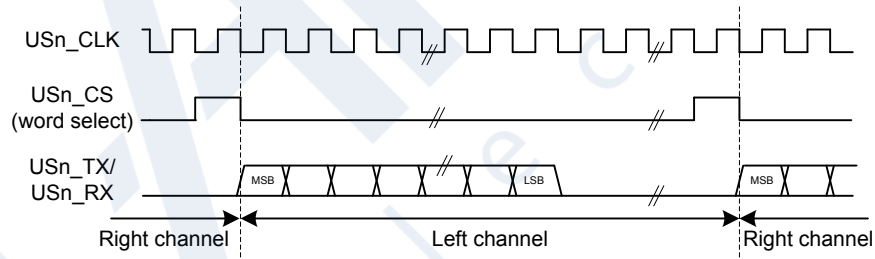

Figure 20.24. USART Mono I2S Waveform

20.3.3.11 Using I2S Mode

When using the USART in I2S mode, `DATABITS` in `USARTn_FRAME` must be set to 8 or 16 data-bits. 8 databits can be used in all modes, and 16 can be used in the modes where the number of bytes in the I2S word is even. In addition to this, `MSBF` in `USARTn_CTRL` should be set, and `CLKPOL` and `CLKPHA` in `USARTn_CTRL` should be cleared.

The USART does not have separate TX and RX buffers for left and right data, so when using I2S in stereo mode, the application must keep track of whether the buffers contain left or right data. This can be done by observing `TXBLRIGHT`, `RXDATAVRIGHT` and `RXFULLRIGHT` in `USARTn_STATUS`. `TXBLRIGHT` tells whether TX is expecting data for the left or right channel. It will be set with `TXBL` if right data is expected. The receiver will set `RXDATAVRIGHT` if there is at least one right element in the buffer, and `RXFULLRIGHT` if the buffer is full of right elements.

When using I2S with DMA, separate DMA requests can be used for left and right data by setting `DMASPLIT` in `USARTn_I2SCTRL`.

In both main and secondary mode the USART always starts transmitting on the LEFT channel after being enabled. In main mode, the transmission will stop if TX becomes empty. In that case, `TXC` is set. Continuing the transmission in this case will make the data-stream continue where it left off. To make the USART start on the LEFT channel after going empty, disable and re-enable TX.

20.3.4 Hardware Flow Control

Hardware flow control can be used to hold off the link partner's transmission until RX buffer space is available. The RTS and CTS signals are enabled and configured using the `GPIO_USARTn_ROUTEEN`, `GPIO_USARTn_RTSMOUTEx` and `GPIO_USARTn_CTSROUTE` registers. RTS is an out going signal which indicates that RX buffer space is available to receive a frame. The link partner is being requested to send its data when RTS is asserted. CTS is an incoming signal to stop the next TX data from going out. When CTS is negated, the frame currently being transmitted is completed before stopping. CTS indicates that the link partner has RX buffer space available, and the local transmitter is clear to send. Also use `CTSEN` in `USARTn_CTRLX` to enable the CTS input into the TX sequencer. For debug use set `DBGHALT` in `USARTn_CTRLX` which will force the RTS to request one frame from the link partner when the CPU core single steps.

20.3.5 Debug Halt

When `DBGHALT` in `USARTn_CTRLX` is clear, RTS is only dependent on the RX buffer having space available to receive data. Incoming data is always received until both the RX buffer is full and the RX shift register is full regardless of the state of `DBGHALT` or chip halt. Additional incoming data is discarded. When `DBGHALT` is set, RTS deasserts on RX buffer full or when chip halt is high. However, a low pulse detected on chip halt will keep RTS asserted when no frame is being received. At the start of frame reception, RTS will deassert if chip halt is high and `DBGHALT` is set. This behavior allows single stepping to pulse the chip halt low for a cycle, and receive the next frame. The link partner must stop transmitting when RTS is deasserted, or the RX buffer could overflow. All data in the transmit buffer is sent out even when chip halt is asserted; therefore, the DMA will need to be set to stop sending the USART TX data during chip halt.

20.3.6 PRS-triggered Transmissions

If a transmission must be started on an event with very little delay, the PRS system can be used to trigger the transmission. The PRS channel to use as a trigger can be selected using `PRSEL` in `PRS_USARTn_TRIGGER`. When a positive edge is detected on this signal, the receiver is enabled if `RXTEN` in `USARTn_TRIGCTRL` is set, and the transmitter is enabled if `TXTEN` in `USARTn_TRIGCTRL` is set. Only one signal input is supported by the USART.

The `AUTOTX` feature can also be enabled via PRS. If an external SPI device sets a pin high when there is data to be read from the device, this signal can be routed to the USART through the PRS system and be used to make the USART clock data out of the external device. If `AUTOTXTEN` in `USARTn_TRIGCTRL` is set, the USART will transmit data whenever the PRS signal selected by `PRS_USARTn_TRIGGER` is high given that there is enough room in the RX buffer for the chosen frame size. Note that if there is no data in the TX buffer when using `AUTOTX`, the TX underflow interrupt will be set.

`AUTOTXTEN` can also be combined with `TXTEN` to make the USART transmit a command to the external device prior to clocking out data. To do this, disable TX using the `TXDIS` command, load the TX buffer with the command and enable `AUTOTXTEN` and `TXTEN`. When the selected PRS input goes high, the USART will now transmit the loaded command, and then continue clocking out while both the PRS input is high and there is room in the RX buffer

20.3.7 PRS RX Input

The USART can be configured to receive data directly from a PRS channel by setting `RXPRSEN` in `USARTn_CTRLX`. The PRS channel used is selected using `PRSEL` in `PRS_USARTn_RX`.

20.3.8 PRS CLK Input

The USART can be configured to receive clock directly from a PRS channel by setting CLKPRSEN in USARTn_CTRLX. The PRS channel used is selected using PRSSEL in PRS_USARTn_CLK. This is useful in synchronous secondary mode and can together with RX PRS input be used to input data from PRS.

20.3.9 DMA Support

The USART has full DMA support. The DMA controller can write to the transmit buffer using the registers USARTn_TXDATA, USARTn_TXDATAx, USARTn_TXDOUBLE and USARTn_TXDOUBLEX, and it can read from the receive buffer using the registers USARTn_RXDATA, USARTn_RXDATAx, USARTn_RXDOUBLE and USARTn_RXDOUBLEX. This enables single byte transfers, 9 bit data + control/status bits, double byte and double byte + control/status transfers both to and from the USART.

A request for the DMA controller to read from the USART receive buffer can come from the following source:

- Data available in the receive buffer
- Data available in the receive buffer and data is for the RIGHT I2S channel. Only used in I2S mode.

A write request can come from one of the following sources:

- Transmit buffer and shift register empty. No data to send.
- Transmit buffer has room for more data. This does not check the TXBIL for half full. For DMA use, it is either full or empty.
- Transmit buffer has room for RIGHT I2S data. Only used in I2S mode

Even though there are two sources for write requests to the DMA, only one should be used at a time, since the requests from both sources are cleared even though only one of the requests are used.

In some cases, it may be sensible to temporarily stop DMA access to the USART when an error such as a framing error has occurred. This is enabled by setting ERRSDMA in USARTn_CTRL.

Note: For Synchronous mode full duplex operation, if both receive buffer and transmit buffer are served by DMA, to make sure receive buffer is not overflowed the settings below should be followed.

- The DMA channel that serves receive buffer should have higher priority than the DMA channel that serves transmit buffer.
- TXBL should be used as write request for transmit buffer DMA channel.
- IGNORESREQ should be set for both DMA channel.

20.3.10 Timer

In addition to the TX sequence timer, there is a versatile 8 bit timer that can generate up to three event pulses. These pulses can be used to create timing for a variety of uses such as RX timeout, break detection, response timeout, and RX enable delay. Transmission delay, CS setup, inter-character spacing, and CS hold use the TX sequence counter. The TX sequencer counter can use the three 8 bit compare values or preset values for delays. There is one general counter with three comparators. Each comparator has a start source, a stop source, a restart enable, and a timer compare value. The start source enables the comparator, resets the counter, and starts the counter. If the counter is already running, the start source will reset the counter and restart it.

Any comparator could start the counter using the same start source but have different timing events programmed into TCMPVALn in USARTn_TIMECMPn. The TCMP0, TCMP1, or TCMP2 events can be preempted by using the comparator stop source to disable the comparator before the counter reaches TCMPVAL0, TCMPVAL1, or TCMPVAL2. If one comparator gets disabled while the other comparator is still enabled, the counter continues counting. By default the counter will count up to 256 and stop unless a RESTARTEN is set in one of the USARTn_TIMECMPn registers. By using RESTARTEN and an interval programmed into TCMPVAL, an interval timer can be set up. The TSTART field needs to be changed to DISABLE to stop the interval timer. The timer stops running once all of the comparators are disabled. If a comparator's start and stop sources both trigger the same cycle, the TCMPn event triggers, the comparator stays enabled, and the counter begins counting from zero.

The TXDELAY, CSSETUP, ICS, and CSHOLD in USARTn_TIMING are used to program start of transmission delay, chip select setup delay, inter-character space, and chip select hold delay. Either a preset value of 0, 1, 2, 3, or 7 can be used for any of these delays; or the value in TCMPVALn may be used to set the delay. Using the preset values leaves the TCMPVALn free for other uses. The same TCMPVALn may be used for multiple events that require the same timing. The transmit sequencer's counter can run in parallel with the timer's counter. The counters and controls are shown in [Figure 20.25 USART Timer Block Diagram on page 589](#).

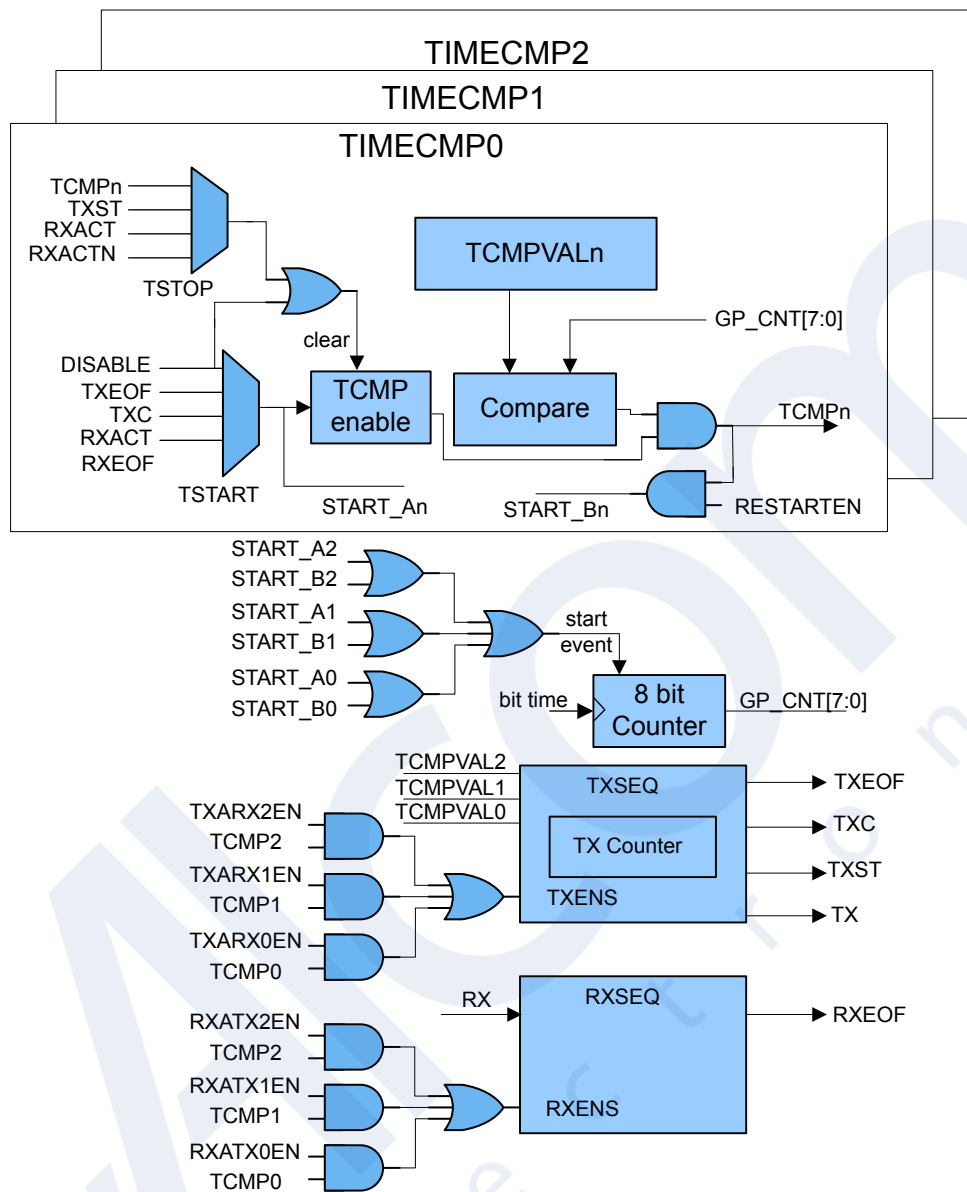

Figure 20.25. USART Timer Block Diagram

The following sections will go into more details on programming the various usage cases.

Table 20.10. USART Application Settings for USARTn_TIMING and USARTn_TIMECMPn

Application	TSTARTn	TSTOPn	TCMPVALn	Other
Response Timeout	TSTART0 = TXEOF	TSTOP0 = RXACT	TCMPVAL0 = 0x08	TCMP0 in USARTn_IEN
Receiver Timeout	TSTART1 = RXEOF	TSTOP1 = RXACT	TCMPVAL1 = 0x08	TCMP1 in USARTn_IEN
Large Receiver Timeout	TSTART1 = RXEOF, TCMP1	TSTOP1 = RXACT	TCMPVAL1 = 0xFF	TCMP1 in USARTn_IEN; TIME-RRESTARTED in USARTn_STATUS; RESTART1EN in USARTn_TIMECMP1

Application	TSTARTn	TSTOPn	TCMPVALn	Other
Break Detect	TSTART1 = RXACT	TSTOP1 = RXACTN	TCMPVAL1 = 0x0C	TCMP1 in USARTn_IEN
TX delayed start of transmission and CS setup	TSTART0 = DISABLE, TSTART1 = DISABLE	TSTOP0 = TCMP0, TSTOP1 = TCMP1	TCMPVAL0 = 0x04, TCMPVAL1 = 0x02	TXDELAY = TCMP0, CSSETUP = TCMP1 in USARTn_TIMING; AUTOCS in USARTn_CTRL
TX inter-character spacing	TSTART2 = DISABLE	TSTOP2 = TCMP2	TCMPVAL2 = 0x03	ICS = TCMP2 in USARTn_TIMING; AUTOCS in USARTn_CTRL
TX Chip Select End Delay	TSTART1 = DISABLE	TSTOP1 = TCMP1	TCMPVAL1 = 0x04	CSHOLD = TCMP1 in USARTn_TIMING; AUTOCS in USARTn_CTRL
Response Delay	TSTART1 = RXEOF	TSTOP1 = TCMP1	TCMPVAL1 = 0x08	TXARX1EN in USARTn_TRIGCTRL
Combined TX and RX Example	TSTART1 = RXEOF, TSTART0 = TXEOF	TSTOP1 = TCMP1, TSTOP0 = TCMP0	TCMPVAL1 = 0x1C, TCMPVAL0 = 0x10	TXARX1EN, RXATX0EN in USARTn_TRIGCTRL; CSSETUP = 0x7, CSHOLD = 0x3 in USARTn_TIMING
Combined Delayed TX and Receiver Timeout Example	TSTART0 = TCMPVAL0, TSTART1 = RXEOF	TSTOP0 = RXACTN, TSTOP1 = RXACT	TCMPVAL0 = 0x20, TCMPVAL1 = 0x0C	TXARX0EN in USARTn_TRIGCTRL; TCMP0 in USARTn_IEN

Table 20.10 USART Application Settings for USARTn_TIMING and USARTn_TIMECMPn on page 589 shows some examples of how the USART timer can be programmed for various applications. The following sections will describe more details for each applications shown in the table.

20.3.10.1 Response Timeout

Response Timeout is when a UART transmitter sends a frame and expects another device to respond within a certain number of baud-times. Refer to Table 20.10 USART Application Settings for USARTn_TIMING and USARTn_TIMECMPn on page 589 for specific register settings. Comparator 0 will be looking for TX end of frame to use as the timer start source. For this example, a receiver start of frame RXACT has not been detected for 8 baud-times, and the TCMP0 interrupt in USARTn_IF is set. If an RX start bit is detected before the 8 baud-times, comparator 0 is disabled before the TCMP0 event can trigger.

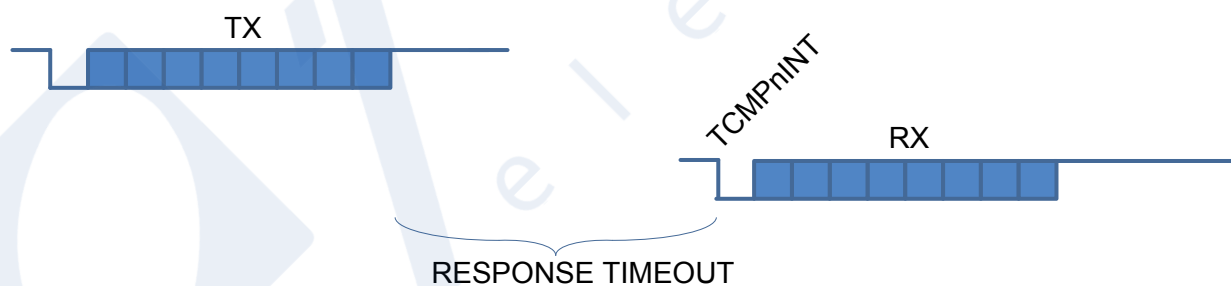

Figure 20.26. USART Response Timeout

20.3.10.2 RX Timeout

A receiver timeout function can be implemented by using the RX end of frame to start comparator 1 and look for the RX start bit RXACT to disable the comparator. See [Table 20.10 USART Application Settings for USARTn_TIMING and USARTn_TIMECMPn on page 589](#) for details on setting up this example. As long as the next RX start bit occurs before the counter reaches the comparator 1 value TCMPVAL1, the interrupt will not get set. In this example the RX Timeout was set to 8 baud-times. To get an RX timeout larger than 256 baud-times, RESTART1EN in USARTn_TIMER can be used to restart the counter when it reaches TCMPVAL1. By setting TCMPVAL1 in USARTn_TIMING to 0xFF, an interrupt will be generated after 256 baud-times. An interrupt service routine can then increment a memory location until the desired timeout is reached. Once the RX start bit is detected, comparator 1 will be disabled. If TIMERRESTARTED in USARTn_STATUS is clear, the TCMP1 interrupt is the first interrupt after RXEOF.

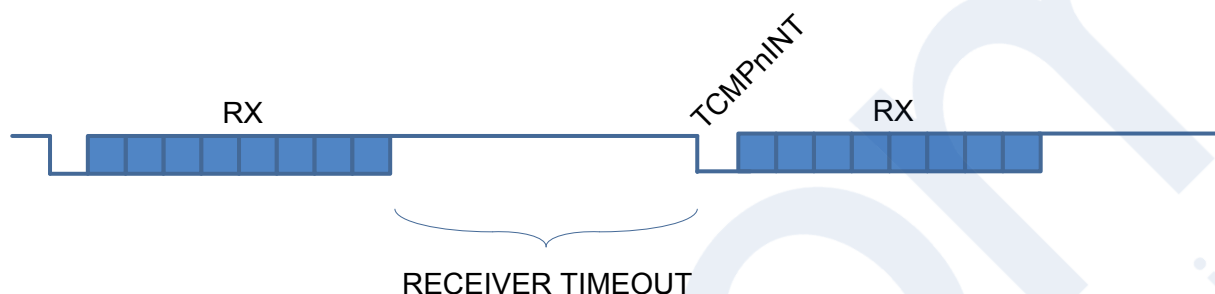

Figure 20.27. USART RX Timeout

20.3.10.3 Break Detect

LIN bus and half-duplex UARTs can take advantage of the timer configured for break detection where RX is held low for a number of baud-times to indicate a break condition. [Table 20.10 USART Application Settings for USARTn_TIMING and USARTn_TIMECMPn on page 589](#) shows the settings for this mode. Each time RX is active (default of low) such as for a start bit, the timer begins counting. If the counter reaches 12 baud-times before RX goes to inactive RXACTN (default of high), an interrupt is asserted.



Figure 20.28. USART Break Detection

20.3.10.4 TX Start Delay

Some applications may require a delay before the start of transmission. This example in [Figure 20.29 USART TXSEQ Timing on page 592](#) shows the TXSEQ timer used to delay the start of transmission by 4 baud times before the start of CS, and by 2 baud times with CS asserted. See [Table 20.10 USART Application Settings for USARTn_TIMING and USARTn_TIMECMPn on page 589](#) for details on how to configure this mode. The TX sequencer could be enabled on PRS and start the TXSEQ counter running for 4 baud times as programmed in TCMPVAL0. Then CS is asserted for 2 baud times before the transmitter begins sending TX data. TXDELAY in USARTn_TIMING is the initial delay before any CS assertion, and CSSETUP is the delay during CS assertion. There are several small preset timing values such as 1, 2, 3, or 7 that can be used for some of the TX sequencer timing which leaves TCMPVAL0, TCMPVAL1, and TCMPVAL2 free for other uses.

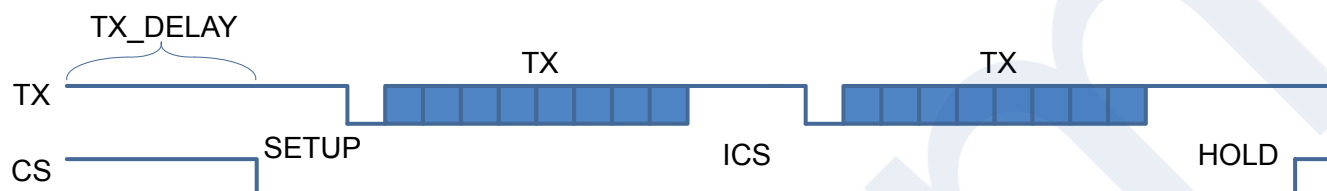

Figure 20.29. USART TXSEQ Timing

20.3.10.5 Inter-Character Space

In addition to delaying the start of frame transmission, it is sometimes necessary to also delay the time between each transmit character (inter-character space). After the first transmission, the inter-character space will delay the start of all subsequent transmissions until the transmit buffer is empty. See [Table 20.10 USART Application Settings for USARTn_TIMING and USARTn_TIMECMPn on page 589](#) for details on setting up this example. For this example in [Figure 20.29 USART TXSEQ Timing on page 592](#) ICS is set to TCMP2 in USARTn_TIMING. To keep CS asserted during the inter-character space, set AUTOCS in USARTn_CTRL. There are a few small preset timing values provided for TX sequence timing. Using these preset timing values can free up the TCMPVALn for other uses. For this example, the inter-character space is set to 0x03 and a preset value could be used.

20.3.10.6 TX Chip Select End Delay

The assertion of CS can be extended after the final character of the frame by using CSHOLD in USARTn_TIMING. See [Table 20.10 USART Application Settings for USARTn_TIMING and USARTn_TIMECMPn on page 589](#) for details on setting up this example. AUTOCS in USARTn_CTRL needs to be set to extend the CS assertion after the last TX character is transmitted as shown in [Figure 20.29 USART TXSEQ Timing on page 592](#).

20.3.10.7 Response Delay

A response delay can be used to hold off the transmitter until a certain number of baud-times after the RX frame. See [Table 20.10 USART Application Settings for USARTn_TIMING and USARTn_TIMECMPn on page 589](#) for details on setting up this example. TXARX1EN in USARTn_TRIGCTRL tells the TX sequencer to trigger after RX EOF plus tcmp1val baud times.

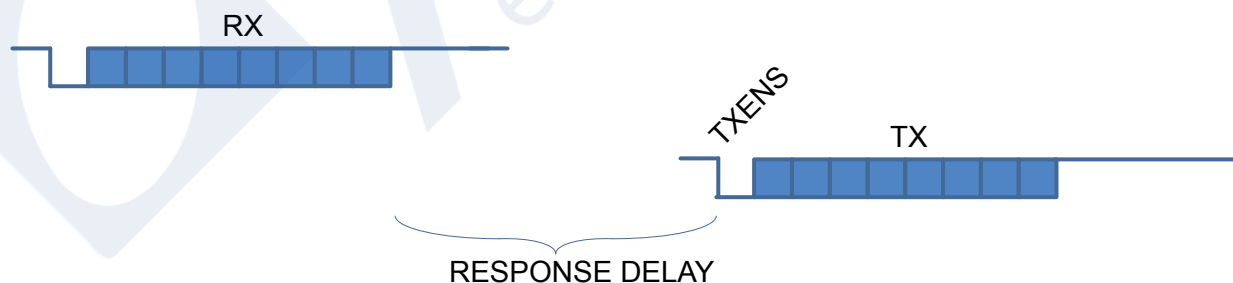

Figure 20.30. USART Response Delay

20.3.10.8 Combined TX and RX Example

This example describes how to alternate between TX and RX frames. This has a 28 baud-time space after RX and a 16 baud-time space after TX. The TSTART1 in USARTn_TIMECMP1 is set to RXEOF which uses the the receiver end of frame to start the timer. The TSTOP1 is set to TCMP1 to generate an event after 28 baud times. Set TXARX1EN in USARTn_TRIGCTRL, and the transmitter is held off until 28 baud times. TCMPVAL in USARTn_TIMECMP1 is set to 0x1C for 28 baud times. By setting TSTART0 in USARTn_TIMECMP0 to TXEOF, the timer will be started after the transmission has completed. RXATX0EN in USARTn_TRIGCTRL is used to delay enabling of the receiver until 16 baud times after the transmitter has completed. Write 0x10 into TCMPVAL of USARTn_TIMECMP0 for a 16 baud time delay. CS is also asserted 7 baud-times before start of transmission by setting CSSETUP to 0x7 in USARTn_TIMING. To keep CS asserted for 3 baud-times after transmission completes, CSHOLD is set to 0x3 in USARTn_TIMING. See [Table 20.10 USART Application Settings for USARTn_TIMING and USARTn_TIMECMPn on page 589](#) for details on setting up this example.

20.3.10.9 Combined TX Delay and RX Break Detect

This example describes how to delay TX transmission after an RX frame and how to have a break condition signal an interrupt. See [Table 20.10 USART Application Settings for USARTn_TIMING and USARTn_TIMECMPn on page 589](#) for details on setting up this example. The TX delay is set up by using transmit after RX, TXARX0EN in USARTn_TRIGCTRL to start the timer. TSTART0 in USARTn_TIMECMP0 is set to RXEOF which enables the transitter of the timer delay. For this example TCMPVAL in USARTn_TIMECMP0 is set to 0x20 to create a 32 baud-time delay between the end of the RX frame and the start of the TX frame. The break detect is configured by setting TSTART1 to RXACT to detect the start bit, and setting TSTOP1 to RXACTN to detect RX going high. In this case the interrupt asserts after RX stays low for 12 baud-times, so TCMPVAL1 is set to 0x0C.

20.3.10.10 Other Stop Conditions

There is also a timer stop on TX start using the TXST setting in TSTOP of USARTn_TIMECMPn. This can be used to see that the DMA has not written to the TXBUFFER for a given time.

20.3.11 Interrupts

The interrupts generated by the USART are combined into two interrupt vectors. Interrupts related to reception are assigned to one interrupt vector, and interrupts related to transmission are assigned to the other. Separating the interrupts in this way allows different priorities to be set for transmission and reception interrupts.

The transmission interrupt vector groups the transmission-related interrupts generated by the following interrupt flags:

- TXC
- TXBL
- TXOF
- CCF
- TXIDLE

The reception interrupt on the other hand groups the reception-related interrupts, triggered by the following interrupt flags:

- RXDATAV
- RXFULL
- RXOF
- RXUF
- PERR
- FERR
- MPAF
- SSM
- TCMPn

If USART interrupts are enabled, an interrupt will be made if one or more of the interrupt flags in USART_IF and their corresponding bits in USART_IEN are set.

20.3.12 IrDA Modulator/ Demodulator

The IrDA modulator implements the physical layer of the IrDA specification, which is necessary for communication over IrDA. The modulator takes the signal output from the USART module, and modulates it before it leaves the USART. In the same way, the input signal is demodulated before it enters the actual USART module. The modulator implements the original Rev. 1.0 physical layer and one high speed extension which supports speeds from 2.4 kbps to 1.152 Mbps.

The data from and to the USART is represented in a NRZ (Non Return to Zero) format, where the signal value is at the same level through the entire bit period. For IrDA, the required format is RZI (Return to Zero Inverted), a format where a “1” is signalled by holding the line low, and a “0” is signalled by a short high pulse. An example is given in [Figure 20.31 USART Example RZI Signal for a given Asynchronous USART Frame on page 594](#).

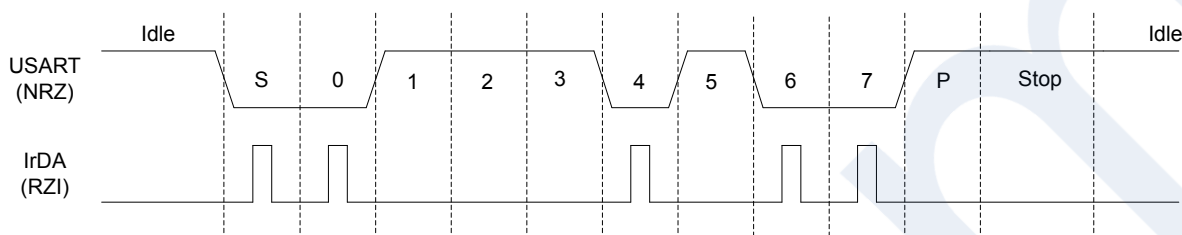

Figure 20.31. USART Example RZI Signal for a given Asynchronous USART Frame

The IrDA module is enabled by setting IREN. The USART transmitter output and receiver input is then routed through the IrDA modulator.

The width of the pulses generated by the IrDA modulator is set by configuring IRPW in USARTn_IRCTRL. Four pulse widths are available, each defined relative to the configured bit period as listed in [Table 20.11 USART IrDA Pulse Widths on page 594](#).

Table 20.11. USART IrDA Pulse Widths

IRPW	Pulse width OVS=0	Pulse width OVS=1	Pulse width OVS=2	Pulse width OVS=3
00	1/16	1/8	1/6	1/4
01	2/16	2/8	2/6	N/A
10	3/16	3/8	N/A	N/A
11	4/16	N/A	N/A	N/A

By default, no filter is enabled in the IrDA demodulator. A filter can be enabled by setting IRFILF in USARTn_IRCTRL. When the filter is enabled, an incoming pulse has to last for 4 consecutive clock cycles to be detected by the IrDA demodulator.

Note that by default, the idle value of the USART data signal is high. This means that the IrDA modulator generates negative pulses, and the IrDA demodulator expects negative pulses. To make the IrDA module use RZI signalling, both TXINV and RXINV in USARTn_CTRL must be set.

20.4 USART Register Map

The offset register address is relative to the registers base address.

Offset	Name	Type	Description
0x000	USART_IPVERSION	R	IPVERSION
0x004	USART_EN	RW	USART Enable
0x008	USART_CTRL	RW	Control Register
0x00C	USART_FRAME	RW	USART Frame Format Register
0x010	USART_TRIGCTRL	RW	USART Trigger Control Register
0x014	USART_CMD	W	Command Register
0x018	USART_STATUS	RH	USART Status Register
0x01C	USART_CLKDIV	RWH	Clock Control Register
0x020	USART_RXDATAEXT	RH	RX Buffer Data Extended Register
0x024	USART_RXDATA	RH	RX Buffer Data Register
0x028	USART_RXDOUBLEX	RH	RX Buffer Double Data Extended Register
0x02C	USART_RXDOUBLE	RH	RX FIFO Double Data Register
0x030	USART_RXDATAEXP	RH	RX Buffer Data Extended Peek Register
0x034	USART_RXDOUBLEXP	RH	RX Buffer Double Data Extended Peek R...
0x038	USART_TXDATAEXT	W	TX Buffer Data Extended Register
0x03C	USART_TXDATA	W	TX Buffer Data Register
0x040	USART_TXDOUBLEX	W	TX Buffer Double Data Extended Register
0x044	USART_TXDOUBLE	W	TX Buffer Double Data Register
0x048	USART_IF	RWH INTFLAG	Interrupt Flag Register
0x04C	USART_IEN	RW	Interrupt Enable Register
0x050	USART_IRCTRL	RW	IrDA Control Register
0x054	USART_I2SCTRL	RW	I2S Control Register
0x058	USART_TIMING	RW	Timing Register
0x05C	USART_CTRLX	RW	Control Register Extended
0x060	USART_TIMECMP0	RW	Timer Compare 0
0x064	USART_TIMECMP1	RW	Timer Compare 1
0x068	USART_TIMECMP2	RW	Timer Compare 2
0x1000	USART_IPVERSION_SET	R	IPVERSION
0x1004	USART_EN_SET	RW	USART Enable
0x1008	USART_CTRL_SET	RW	Control Register
0x100C	USART_FRAME_SET	RW	USART Frame Format Register
0x1010	USART_TRIGCTRL_SET	RW	USART Trigger Control Register
0x1014	USART_CMD_SET	W	Command Register
0x1018	USART_STATUS_SET	RH	USART Status Register
0x101C	USART_CLKDIV_SET	RWH	Clock Control Register

Offset	Name	Type	Description
0x1020	USART_RXDATA_X_SET	RH	RX Buffer Data Extended Register
0x1024	USART_RXDATA_SET	RH	RX Buffer Data Register
0x1028	USART_RXDOUBLE_X_SET	RH	RX Buffer Double Data Extended Register
0x102C	USART_RXDOUBLE_SET	RH	RX FIFO Double Data Register
0x1030	USART_RXDATA_XP_SET	RH	RX Buffer Data Extended Peek Register
0x1034	USART_RXDOUBLEXP_SET	RH	RX Buffer Double Data Extended Peek R...
0x1038	USART_TXDATA_X_SET	W	TX Buffer Data Extended Register
0x103C	USART_TXDATA_SET	W	TX Buffer Data Register
0x1040	USART_TXDOUBLE_X_SET	W	TX Buffer Double Data Extended Register
0x1044	USART_TXDOUBLE_SET	W	TX Buffer Double Data Register
0x1048	USART_IF_SET	RWH INTFLAG	Interrupt Flag Register
0x104C	USART_IEN_SET	RW	Interrupt Enable Register
0x1050	USART_IRCTRL_SET	RW	IrDA Control Register
0x1054	USART_I2SCTRL_SET	RW	I2S Control Register
0x1058	USART_TIMING_SET	RW	Timing Register
0x105C	USART_CTRLX_SET	RW	Control Register Extended
0x1060	USART_TIMECMP0_SET	RW	Timer Compare 0
0x1064	USART_TIMECMP1_SET	RW	Timer Compare 1
0x1068	USART_TIMECMP2_SET	RW	Timer Compare 2
0x2000	USART_IPVERSION_CLR	R	IPVERSION
0x2004	USART_EN_CLR	RW	USART Enable
0x2008	USART_CTRL_CLR	RW	Control Register
0x200C	USART_FRAME_CLR	RW	USART Frame Format Register
0x2010	USART_TRIGCTRL_CLR	RW	USART Trigger Control Register
0x2014	USART_CMD_CLR	W	Command Register
0x2018	USART_STATUS_CLR	RH	USART Status Register
0x201C	USART_CLKDIV_CLR	RWH	Clock Control Register
0x2020	USART_RXDATA_X_CLR	RH	RX Buffer Data Extended Register
0x2024	USART_RXDATA_CLR	RH	RX Buffer Data Register
0x2028	USART_RXDOUBLE_X_CLR	RH	RX Buffer Double Data Extended Register
0x202C	USART_RXDOUBLE_CLR	RH	RX FIFO Double Data Register
0x2030	USART_RXDATA_XP_CLR	RH	RX Buffer Data Extended Peek Register
0x2034	USART_RXDOUBLEXP_CLR	RH	RX Buffer Double Data Extended Peek R...
0x2038	USART_TXDATA_X_CLR	W	TX Buffer Data Extended Register
0x203C	USART_TXDATA_CLR	W	TX Buffer Data Register
0x2040	USART_TXDOUBLE_X_CLR	W	TX Buffer Double Data Extended Register
0x2044	USART_TXDOUBLE_CLR	W	TX Buffer Double Data Register

Offset	Name	Type	Description
0x2048	USART_IF_CLR	RWH INTFLAG	Interrupt Flag Register
0x204C	USART_IEN_CLR	RW	Interrupt Enable Register
0x2050	USART_IRCTRL_CLR	RW	IrDA Control Register
0x2054	USART_I2SCTRL_CLR	RW	I2S Control Register
0x2058	USART_TIMING_CLR	RW	Timing Register
0x205C	USART_CTRLX_CLR	RW	Control Register Extended
0x2060	USART_TIMECMP0_CLR	RW	Timer Compare 0
0x2064	USART_TIMECMP1_CLR	RW	Timer Compare 1
0x2068	USART_TIMECMP2_CLR	RW	Timer Compare 2
0x3000	USART_IPVERSION_TGL	R	IPVERSION
0x3004	USART_EN_TGL	RW	USART Enable
0x3008	USART_CTRL_TGL	RW	Control Register
0x300C	USART_FRAME_TGL	RW	USART Frame Format Register
0x3010	USART_TRIGCTRL_TGL	RW	USART Trigger Control Register
0x3014	USART_CMD_TGL	W	Command Register
0x3018	USART_STATUS_TGL	RH	USART Status Register
0x301C	USART_CLKDIV_TGL	RWH	Clock Control Register
0x3020	USART_RXDATAX_TGL	RH	RX Buffer Data Extended Register
0x3024	USART_RXDATA_TGL	RH	RX Buffer Data Register
0x3028	USART_RXDOUBLEX_TGL	RH	RX Buffer Double Data Extended Register
0x302C	USART_RXDOUBLE_TGL	RH	RX FIFO Double Data Register
0x3030	USART_RXDATAXP_TGL	RH	RX Buffer Data Extended Peek Register
0x3034	USART_RXDOUBLEXP_TGL	RH	RX Buffer Double Data Extended Peek R...
0x3038	USART_TXDATAX_TGL	W	TX Buffer Data Extended Register
0x303C	USART_TXDATA_TGL	W	TX Buffer Data Register
0x3040	USART_TXDOUBLEX_TGL	W	TX Buffer Double Data Extended Register
0x3044	USART_TXDOUBLE_TGL	W	TX Buffer Double Data Register
0x3048	USART_IF_TGL	RWH INTFLAG	Interrupt Flag Register
0x304C	USART_IEN_TGL	RW	Interrupt Enable Register
0x3050	USART_IRCTRL_TGL	RW	IrDA Control Register
0x3054	USART_I2SCTRL_TGL	RW	I2S Control Register
0x3058	USART_TIMING_TGL	RW	Timing Register
0x305C	USART_CTRLX_TGL	RW	Control Register Extended
0x3060	USART_TIMECMP0_TGL	RW	Timer Compare 0
0x3064	USART_TIMECMP1_TGL	RW	Timer Compare 1
0x3068	USART_TIMECMP2_TGL	RW	Timer Compare 2

20.5 USART Register Description

20.5.1 USART_IPVERSION - IPVERSION

Offset	Bit Position																															
0x000	31	30	29	28	27	26	25	24	23	22	21	20	19	18	17	16	15	14	13	12	11	10	9	8	7	6	5	4	3	2	1	0
Reset																																0x0
Access																																R
Name																																IPVERSION

Bit	Name	Reset	Access	Description
31:0	IPVERSION	0x0	R	IPVERSION The read only IPVERSION field gives the version for this module. There may be minor software changes required for modules with different values of IPVERSION.

20.5.2 USART_EN - USART Enable

Offset	Bit Position																															
0x004	31	30	29	28	27	26	25	24	23	22	21	20	19	18	17	16	15	14	13	12	11	10	9	8	7	6	5	4	3	2	1	0
Reset																																0x0
Access																																RW
Name																																EN

Bit	Name	Reset	Access	Description
31:1	<i>Reserved</i>	<i>To ensure compatibility with future devices, always write Reserved bits to their reset value, unless otherwise stated. More information in 1.2 Conventions</i>		
0	EN	0x0	RW	USART Enable The ENABLE bit enables the module.

20.5.3 USART_CTRL - Control Register

Offset	Bit Position																																
0x008	31	30	29	28	27	26	25	24	23	22	21	20	19	18	17	16	15	14	13	12	11	10	9	8	7	6	5	4	3	2	1	0	
Reset	0x0	0x0	0x0	0x0			0x0	0x0	0x0	0x0	0x0	0x0	0x0	0x0	0x0	0x0	0x0	0x0	0x0	0x0	0x0	0x0	0x0	0x0			0x0	0x0	0x0	0x0	0x0	0x0	0x0
Access	RW	RW	RW	RW			RW	RW	RW	RW	RW	RW	RW	RW	RW	RW	RW	RW	RW	RW	RW	RW	RW	RW			RW	RW	RW	RW	RW	RW	RW
Name	SMSDELAY	MVDIS	AUTOTX	BYTESWAP			SSSEARLY	ERRSTX	ERRSRX	ERRSDMA	BIT8DV	SKIPPERRF	SCRETRANS	SCMODE	AUTOTRI	AUTOCS	CSINV	TXINV	RXINV	TXBIL	CSMA	MSBF	CLKPHA	CLKPOL			OVS	MPAB	MPM	CCEN	LOOPBK	SYNC	

Bit	Name	Reset	Access	Description
31	SMSDELAY	0x0	RW	Synchronous Main Sample Delay Delay Synchronous Main interface sample point to the next setup edge to improve timing and allow communication at higher speeds
30	MVDIS	0x0	RW	Majority Vote Disable Disable majority vote for 16x, 8x and 6x oversampling modes.
29	AUTOTX	0x0	RW	Always Transmit When RX Not Full Transmits as long as RX is not full. If TX is empty, underflows are generated.
28	BYTESWAP	0x0	RW	Byteswap In Double Accesses Set to switch the order of the bytes in double accesses.
	Value	Mode		Description
	0	DISABLE		Normal byte order
	1	ENABLE		Byte order swapped
27:26	<i>Reserved</i>			<i>To ensure compatibility with future devices, always write Reserved bits to their reset value, unless otherwise stated. More information in 1.2 Conventions</i>
25	SSSEARLY	0x0	RW	Synchronous Secondary Setup Early Setup data on sample edge in synchronous secondary interface mode to improve MOSI setup time
24	ERRSTX	0x0	RW	Disable TX On Error When set, the transmitter is disabled on framing and parity errors (asynchronous mode only) in the receiver.
	Value	Mode		Description
	0	DISABLE		Received framing and parity errors have no effect on transmitter
	1	ENABLE		Received framing and parity errors disable the transmitter
23	ERRSRX	0x0	RW	Disable RX On Error When set, the receiver is disabled on framing and parity errors (asynchronous mode only).
	Value	Mode		Description
	0	DISABLE		Framing and parity errors have no effect on receiver
	1	ENABLE		Framing and parity errors disable the receiver

Bit	Name	Reset	Access	Description
22	ERRSDMA	0x0	RW	Halt DMA On Error When set, DMA requests will be cleared on framing and parity errors (asynchronous mode only).
	Value	Mode		Description
	0	DISABLE		Framing and parity errors have no effect on DMA requests from the USART
	1	ENABLE		DMA requests from the USART are blocked while the PERR or FERR interrupt flags are set
21	BIT8DV	0x0	RW	Bit 8 Default Value The default value of the 9th bit. If 9-bit frames are used, and an 8-bit write operation is done, leaving the 9th bit unspecified, the 9th bit is set to the value of BIT8DV.
20	SKIPPERRF	0x0	RW	Skip Parity Error Frames When set, the receiver discards frames with parity errors (asynchronous mode only). The PERR interrupt flag is still set.
19	SCRETRANS	0x0	RW	SmartCard Retransmit When in SmartCard mode, a NACK'ed frame will be kept in the shift register and retransmitted if the transmitter is still enabled.
18	SCMODE	0x0	RW	SmartCard Mode Use this bit to enable or disable SmartCard mode.
17	AUTOTRI	0x0	RW	Automatic TX Tristate When enabled, TXTRI is set by hardware whenever the transmitter is idle, and TXTRI is cleared by hardware when transmission starts.
	Value	Mode		Description
	0	DISABLE		The output on U(S)n_TX when the transmitter is idle is defined by TXINV
	1	ENABLE		U(S)n_TX is tristated whenever the transmitter is idle
16	AUTOCS	0x0	RW	Automatic Chip Select When enabled, the output on USn_CS will be activated one baud-period before transmission starts, and deactivated when transmission ends.
15	CSINV	0x0	RW	Chip Select Invert Default value is active low. This affects both the selection of external secondaries, as well as the selection of the micro-controller as a secondary interface.
	Value	Mode		Description
	0	DISABLE		Chip select is active low
	1	ENABLE		Chip select is active high
14	TXINV	0x0	RW	Transmitter output Invert The output from the USART transmitter can optionally be inverted by setting this bit.
	Value	Mode		Description
	0	DISABLE		Output from the transmitter is passed unchanged to U(S)n_TX
	1	ENABLE		Output from the transmitter is inverted before it is passed to U(S)n_TX

Bit	Name	Reset	Access	Description
13	RXINV	0x0	RW	Receiver Input Invert Setting this bit will invert the input to the USART receiver.
	Value	Mode		Description
	0	DISABLE		Input is passed directly to the receiver
	1	ENABLE		Input is inverted before it is passed to the receiver
12	TXBIL	0x0	RW	TX Buffer Interrupt Level Determines the interrupt and status level of the transmit buffer.
	Value	Mode		Description
	0	EMPTY		TXBL and the TXBL interrupt flag are set when the transmit buffer becomes empty. TXBL is cleared when the buffer becomes nonempty.
	1	HALFFULL		TXBL and TXBLIF are set when the transmit buffer goes from full to half-full or empty. TXBL is cleared when the buffer becomes full.
11	CSMA	0x0	RW	Action On Chip Select In Main Mode This register determines the action to be performed when chip select is configured as an input and driven low while in main interface mode.
	Value	Mode		Description
	0	NOACTION		No action taken
	1	GOTOSLAVEMODE		Go to secondary mode
10	MSBF	0x0	RW	Most Significant Bit First Decides whether data is sent with the least significant bit first, or the most significant bit first.
	Value	Mode		Description
	0	DISABLE		Data is sent with the least significant bit first
	1	ENABLE		Data is sent with the most significant bit first
9	CLKPHA	0x0	RW	Clock Edge For Setup/Sample Determines where data is set-up and sampled according to the bus clock when in synchronous mode.
	Value	Mode		Description
	0	SAMPLELEADING		Data is sampled on the leading edge and set-up on the trailing edge of the bus clock in synchronous mode
	1	SAMPLETRAILING		Data is set-up on the leading edge and sampled on the trailing edge of the bus clock in synchronous mode
8	CLKPOL	0x0	RW	Clock Polarity Determines the clock polarity of the bus clock used in synchronous mode.
	Value	Mode		Description
	0	IDLELOW		The bus clock used in synchronous mode has a low base value

Bit	Name	Reset	Access	Description
1		IDLEHIGH		The bus clock used in synchronous mode has a high base value
7	<i>Reserved</i>	<i>To ensure compatibility with future devices, always write Reserved bits to their reset value, unless otherwise stated. More information in 1.2 Conventions</i>		
6:5	OVS	0x0	RW	Oversampling Sets the number of clock periods in a UART bit-period. More clock cycles gives better robustness, while less clock cycles gives better performance.
	Value	Mode		Description
	0	X16		Regular UART mode with 16X oversampling in asynchronous mode
	1	X8		Double speed with 8X oversampling in asynchronous mode
	2	X6		6X oversampling in asynchronous mode
	3	X4		Quadruple speed with 4X oversampling in asynchronous mode
4	MPAB	0x0	RW	Multi-Processor Address-Bit Defines the value of the multi-processor address bit. An incoming frame with its 9th bit equal to the value of this bit marks the frame as a multi-processor address frame.
3	MPM	0x0	RW	Multi-Processor Mode Multi-processor mode uses the 9th bit of the USART frames to tell whether the frame is an address frame or a data frame.
	Value	Mode		Description
	0	DISABLE		The 9th bit of incoming frames has no special function
	1	ENABLE		An incoming frame with the 9th bit equal to MPAB will be loaded into the receive buffer regardless of RXBLOCK and will result in the MPAB interrupt flag being set
2	CCEN	0x0	RW	Collision Check Enable Enables collision checking on data when operating in half duplex modus.
	Value	Mode		Description
	0	DISABLE		Collision check is disabled
	1	ENABLE		Collision check is enabled. The receiver must be enabled for the check to be performed
1	LOOPBK	0x0	RW	Loopback Enable Allows the receiver to be connected directly to the USART transmitter for loopback and half duplex communication.
	Value	Mode		Description
	0	DISABLE		The receiver is connected to and receives data from U(S)n_RX
	1	ENABLE		The receiver is connected to and receives data from U(S)n_TX
0	SYNC	0x0	RW	USART Synchronous Mode Determines whether the USART is operating in asynchronous or synchronous mode.
	Value	Mode		Description

Bit	Name	Reset	Access	Description
0		DISABLE		The USART operates in asynchronous mode
1		ENABLE		The USART operates in synchronous mode



20.5.4 USART_FRAME - USART Frame Format Register

Offset	Bit Position																															
0x00C	31	30	29	28	27	26	25	24	23	22	21	20	19	18	17	16	15	14	13	12	11	10	9	8	7	6	5	4	3	2	1	0
Reset																	0x1		0x0			0x5										
Access																	RW		RW			RW										
Name																	STOPBITS		PARITY			DATABITS										

Bit	Name	Reset	Access	Description
31:14	<i>Reserved</i>	<i>To ensure compatibility with future devices, always write Reserved bits to their reset value, unless otherwise stated. More information in 1.2 Conventions</i>		
13:12	STOPBITS	0x1	RW	Stop-Bit Mode Determines the number of stop-bits used.
	Value	Mode		Description
	0	HALF		The transmitter generates a half stop bit. Stop-bits are not verified by receiver
	1	ONE		One stop bit is generated and verified
	2	ONEANDAHALF		The transmitter generates one and a half stop bit. The receiver verifies the first stop bit
	3	TWO		The transmitter generates two stop bits. The receiver checks the first stop-bit only
11:10	<i>Reserved</i>	<i>To ensure compatibility with future devices, always write Reserved bits to their reset value, unless otherwise stated. More information in 1.2 Conventions</i>		
9:8	PARITY	0x0	RW	Parity-Bit Mode Determines whether parity bits are enabled, and whether even or odd parity should be used. Only available in asynchronous mode.
	Value	Mode		Description
	0	NONE		Parity bits are not used
	2	EVEN		Even parity are used. Parity bits are automatically generated and checked by hardware.
	3	ODD		Odd parity is used. Parity bits are automatically generated and checked by hardware.
7:4	<i>Reserved</i>	<i>To ensure compatibility with future devices, always write Reserved bits to their reset value, unless otherwise stated. More information in 1.2 Conventions</i>		
3:0	DATABITS	0x5	RW	Data-Bit Mode This register sets the number of data bits in a USART frame.
	Value	Mode		Description
	1	FOUR		Each frame contains 4 data bits
	2	FIVE		Each frame contains 5 data bits

Bit	Name	Reset	Access	Description
3	SIX			Each frame contains 6 data bits
4	SEVEN			Each frame contains 7 data bits
5	EIGHT			Each frame contains 8 data bits
6	NINE			Each frame contains 9 data bits
7	TEN			Each frame contains 10 data bits
8	ELEVEN			Each frame contains 11 data bits
9	TWELVE			Each frame contains 12 data bits
10	THIRTEEN			Each frame contains 13 data bits
11	FOURTEEN			Each frame contains 14 data bits
12	FIFTEEN			Each frame contains 15 data bits
13	SIXTEEN			Each frame contains 16 data bits

20.5.5 USART_TRIGCTRL - USART Trigger Control Register

Offset	Bit Position																																																
0x010	31	30	29	28	27	26	25	24	23	22	21	20	19	18	17	16	15	14	13	12	11	10	9	8	7	6	5	4	3	2	1	0																	
Reset																	0x0	0x0	0x0	0x0	0x0	0x0	0x0	0x0	0x0	0x0	0x0	0x0	0x0	0x0	0x0	0x0	0x0	0x0	0x0	0x0	0x0	0x0	0x0	0x0	0x0	0x0	0x0	0x0	0x0	0x0	0x0	0x0	
Access																	RW	RW	RW	RW	RW	RW	RW	RW	RW	RW	RW	RW	RW	RW	RW	RW	RW	RW	RW	RW	RW	RW	RW	RW	RW	RW	RW	RW	RW	RW	RW	RW	RW
Name																	RXATX2EN	RXATX1EN	RXATX0EN	TXARX2EN	TXARX1EN	TXARX0EN	AUTOTXTEN	TXTEN	RXTEN																								

Bit	Name	Reset	Access	Description
31:13	Reserved			To ensure compatibility with future devices, always write Reserved bits to their reset value, unless otherwise stated. More information in 1.2 Conventions
12	RXATX2EN	0x0	RW	Enable Receive Trigger after TX end of f When set, a TX end of frame will trigger the receiver after a TCMPVAL2 baud-time delay
11	RXATX1EN	0x0	RW	Enable Receive Trigger after TX end of f When set, a TX end of frame will trigger the receiver after a TCMPVAL1 baud-time delay
10	RXATX0EN	0x0	RW	Enable Receive Trigger after TX end of f When set, a TX end of frame will trigger the receiver after a TCMPVAL0 baud-time delay
9	TXARX2EN	0x0	RW	Enable Transmit Trigger after RX End of When set, an RX end of frame will trigger the transmitter after TCMP2VAL bit times to force a minimum response delay
8	TXARX1EN	0x0	RW	Enable Transmit Trigger after RX End of When set, an RX end of frame will trigger the transmitter after TCMP1VAL bit times to force a minimum response delay
7	TXARX0EN	0x0	RW	Enable Transmit Trigger after RX End of When set, an RX end of frame will trigger the transmitter after TCMP0VAL bit times to force a minimum response delay
6	AUTOTXTEN	0x0	RW	AUTOTX Trigger Enable When set, AUTOTX is enabled as long as the PRS channel selected by TSEL has a high value
5	TXTEN	0x0	RW	Transmit Trigger Enable When set, the PRS channel selected by TSEL sets TXEN, enabling the transmitter on positive trigger edges.
4	RXTEN	0x0	RW	Receive Trigger Enable When set, the PRS channel selected by TSEL sets RXEN, enabling the receiver on positive trigger edges.
3:0	Reserved			To ensure compatibility with future devices, always write Reserved bits to their reset value, unless otherwise stated. More information in 1.2 Conventions

20.5.6 USART_CMD - Command Register

Offset	Bit Position																																																			
0x014	31	30	29	28	27	26	25	24	23	22	21	20	19	18	17	16	15	14	13	12	11	10	9	8	7	6	5	4	3	2	1	0																				
Reset																					0x0	0x0	0x0	0x0	0x0	0x0	0x0	0x0	0x0	0x0	0x0	0x0	0x0	0x0	0x0	0x0	0x0	0x0	0x0	0x0	0x0	0x0	0x0	0x0	0x0	0x0	0x0	0x0	0x0	0x0	0x0	0x0
Access																					W(nB)	W(nB)	W(nB)	W(nB)	W(nB)	W(nB)	W(nB)	W(nB)	W(nB)	W(nB)	W(nB)	W(nB)	W(nB)	W(nB)	W(nB)	W(nB)	W(nB)	W(nB)	W(nB)	W(nB)	W(nB)	W(nB)	W(nB)	W(nB)	W(nB)	W(nB)	W(nB)	W(nB)	W(nB)	W(nB)	W(nB)	W(nB)
Name																					CLEARRX	CLEARTX	TXTRIDIS	TXTRIEN	RXBLOCKDIS	RXBLOCKEN	MASTERDIS	MASTEREN	TXDIS	TXEN	RXDIS	RXEN																				

Bit	Name	Reset	Access	Description
31:12	<i>Reserved</i>	<i>To ensure compatibility with future devices, always write Reserved bits to their reset value, unless otherwise stated. More information in 1.2 Conventions</i>		
11	CLEARRX	0x0	W(nB)	Clear RX Set to clear receive buffer and the RX shift register.
10	CLEARTX	0x0	W(nB)	Clear TX Set to clear transmit buffer and the TX shift register.
9	TXTRIDIS	0x0	W(nB)	Transmitter Tristate Disable Disables tristating of the transmitter output.
8	TXTRIEN	0x0	W(nB)	Transmitter Tristate Enable Tristates the transmitter output.
7	RXBLOCKDIS	0x0	W(nB)	Receiver Block Disable Set to clear RXBLOCK, resulting in all incoming frames being loaded into the receive buffer.
6	RXBLOCKEN	0x0	W(nB)	Receiver Block Enable Set to set RXBLOCK, resulting in all incoming frames being discarded.
5	MASTERDIS	0x0	W(nB)	Main Mode Disable Set to disable main interface mode, clearing the MASTER status bit and putting the USART in secondary interface mode.
4	MASTEREN	0x0	W(nB)	Main Mode Enable Set to enable main interface mode, setting the MASTER status bit. Main mode should not be enabled while TXENS is set to 1. To enable both main interface and TX mode, write MASTEREN before TXEN, or enable them both in the same write operation.
3	TXDIS	0x0	W(nB)	Transmitter Disable Set to disable transmission.
2	TXEN	0x0	W(nB)	Transmitter Enable Set to enable data transmission.
1	RXDIS	0x0	W(nB)	Receiver Disable Set to disable data reception. If a frame is under reception when the receiver is disabled, the incoming frame is discarded.
0	RXEN	0x0	W(nB)	Receiver Enable

Bit	Name	Reset	Access	Description
				Set to activate data reception on U(S)n_RX.



20.5.7 USART_STATUS - USART Status Register

Offset	Bit Position																																																		
0x018	31	30	29	28	27	26	25	24	23	22	21	20	19	18	17	16	15	14	13	12	11	10	9	8	7	6	5	4	3	2	1	0																			
Reset																	0x0		0x0	0x1	0x0	0x0	0x0	0x0	0x0	0x0	0x0	0x0	0x0	0x1	0x0	0x0	0x0	0x0	0x0	0x0	0x0	0x0	0x0	0x0	0x0	0x0	0x0	0x0	0x0	0x0	0x0				
Access																	R		R	R	R	R	R	R	R	R	R	R	R	R	R	R	R	R	R	R	R	R	R	R	R	R	R	R	R	R	R	R	R	R	
Name																	TXBUFCNT		TIMERRESTARTED	TXIDLE	RXFULLRIGHT	RXDATAVRIGHT	TXBSRIGHT	TXBDRIGHT	RXFULL	RXDATAV	TXBL	TXC	TXTRI	RXBLOCK	MASTER	TXENS	RXENS																		

Bit	Name	Reset	Access	Description
31:18	Reserved			To ensure compatibility with future devices, always write Reserved bits to their reset value, unless otherwise stated. More information in 1.2 Conventions
17:16	TXBUFCNT	0x0	R	TX Buffer Count Count of TX buffer entry 0, entry 1, and TX shift register. For large frames, the count is only of TX buffer entry 0 and the TX shifter register.
15	Reserved			To ensure compatibility with future devices, always write Reserved bits to their reset value, unless otherwise stated. More information in 1.2 Conventions
14	TIMERRESTARTED	0x0	R	The USART Timer restarted itself When the timer is restarting itself on each TCMP event, a TIMERRESTARTED value of 0x0 indicates the first TCMP event in the sequence of multiple TCMP events. Any non TCMP timer start events will clear TIMERRESTARTED. When there is a TCMP interrupt and TIMERRESTARTED is 0x0, an interrupt service routine can set a TCMP event counter variable in memory to 0x1 to indicate the first TCMP interrupt of the sequence.
13	TXIDLE	0x1	R	TX Idle Set when TX idle
12	RXFULLRIGHT	0x0	R	RX Full of Right Data When set, the entire RX buffer contains right data. Only used in I2S mode
11	RXDATAVRIGHT	0x0	R	RX Data Right When set, reading RXDATA or RXDATAV gives right data. Else left data is read. Only used in I2S mode
10	TXBSRIGHT	0x0	R	TX Buffer Expects Single Right Data When set, the TX buffer expects at least a single right data. Else it expects left data. Only used in I2S mode
9	TXBDRIGHT	0x0	R	TX Buffer Expects Double Right Data When set, the TX buffer expects double right data. Else it may expect a single right data or left data. Only used in I2S mode
8	RXFULL	0x0	R	RX FIFO Full Set when the RXFIFO is full. Cleared when the receive buffer is no longer full. When this bit is set, there is still room for one more frame in the receive shift register.
7	RXDATAV	0x0	R	RX Data Valid Set when data is available in the receive buffer. Cleared when the receive buffer is empty.
6	TXBL	0x1	R	TX Buffer Level

Bit	Name	Reset	Access	Description
				Indicates the level of the transmit buffer. If TXBIL is 0x0, TXBL is set whenever the transmit buffer is completely empty. Otherwise TXBL is set whenever the TX Buffer becomes half full.
5	TXC	0x0	R	TX Complete Set when a transmission has completed and no more data is available in the transmit buffer and shift register. Cleared when data is written to the transmit buffer.
4	TXTRI	0x0	R	Transmitter Tristated Set when the transmitter is tristated, and cleared when transmitter output is enabled. If AUTOTRI in USARTn_CTRL is set this bit is always read as 0.
3	RXBLOCK	0x0	R	Block Incoming Data When set, the receiver discards incoming frames. An incoming frame will not be loaded into the receive buffer if this bit is set at the instant the frame has been completely received.
2	MASTER	0x0	R	SPI Main Mode Set when the USART operates as a main interface. Set using the MASTEREN command and clear using the MASTER-DIS command.
1	TXENS	0x0	R	Transmitter Enable Status Set when the transmitter is enabled.
0	RXENS	0x0	R	Receiver Enable Status Set when the receiver is enabled.

20.5.8 USART_CLKDIV - Clock Control Register

Offset	Bit Position																																	
0x01C	31	30	29	28	27	26	25	24	23	22	21	20	19	18	17	16	15	14	13	12	11	10	9	8	7	6	5	4	3	2	1	0		
Reset	0x0																																	
Access	RW																																	
Name	AUTOBAUDEN																																	

Bit	Name	Reset	Access	Description
31	AUTOBAUDEN	0x0	RW	AUTOBAUD detection enable Detects the baud rate based on receiving a 0x55 frame (0x00 for IrDA). This is used in Asynchronous mode.
30:23	<i>Reserved</i>	<i>To ensure compatibility with future devices, always write Reserved bits to their reset value, unless otherwise stated. More information in 1.2 Conventions</i>		
22:3	DIV	0x0	RW	Fractional Clock Divider Specifies the fractional clock divider for the USART. Setting AUTOBAUDEN in USARTn_CLKDIV will overwrite the DIV field.
2:0	<i>Reserved</i>	<i>To ensure compatibility with future devices, always write Reserved bits to their reset value, unless otherwise stated. More information in 1.2 Conventions</i>		

20.5.9 USART_RXDATAx - RX Buffer Data Extended Register

Offset	Bit Position																															
0x020	31	30	29	28	27	26	25	24	23	22	21	20	19	18	17	16	15	14	13	12	11	10	9	8	7	6	5	4	3	2	1	0
Reset																	0x0	0x0											0x0			
Access																	R	R											R			
Name																	FERR	PERR											RXDATA			

Bit	Name	Reset	Access	Description
31:16	Reserved	To ensure compatibility with future devices, always write Reserved bits to their reset value, unless otherwise stated. More information in 1.2 Conventions		
15	FERR	0x0	R	Data Framing Error Set if data in buffer has a framing error. Can be the result of a break condition.
14	PERR	0x0	R	Data Parity Error Set if data in buffer has a parity error (asynchronous mode only).
13:9	Reserved	To ensure compatibility with future devices, always write Reserved bits to their reset value, unless otherwise stated. More information in 1.2 Conventions		
8:0	RXDATA	0x0	R	RX Data Use this register to access data read from the USART. Buffer is cleared on read access.

20.5.10 USART_RXDATA - RX Buffer Data Register

Offset	Bit Position																																
0x024	31	30	29	28	27	26	25	24	23	22	21	20	19	18	17	16	15	14	13	12	11	10	9	8	7	6	5	4	3	2	1	0	
Reset																																	0x0
Access																																	R
Name																																	RXDATA

Bit	Name	Reset	Access	Description
31:8	Reserved	To ensure compatibility with future devices, always write Reserved bits to their reset value, unless otherwise stated. More information in 1.2 Conventions		
7:0	RXDATA	0x0	R	RX Data Use this register to access data read from USART. Buffer is cleared on read access. Only the 8 LSB can be read using this register.

20.5.11 USART_RXDOUBLEX - RX Buffer Double Data Extended Register

Offset	Bit Position																															
0x028	31	30	29	28	27	26	25	24	23	22	21	20	19	18	17	16	15	14	13	12	11	10	9	8	7	6	5	4	3	2	1	0
Reset	0x0	0x0										0x0					0x0	0x0														0x0
Access	R	R										R					R	R														R
Name	FERR1	PERR1										RXDATA1					FERR0	PERR0														RXDATA0

Bit	Name	Reset	Access	Description
31	FERR1	0x0	R	Data Framing Error 1 Set if data in buffer has a framing error. Can be the result of a break condition.
30	PERR1	0x0	R	Data Parity Error 1 Set if data in buffer has a parity error (asynchronous mode only).
29:25	<i>Reserved</i>	<i>To ensure compatibility with future devices, always write Reserved bits to their reset value, unless otherwise stated. More information in 1.2 Conventions</i>		
24:16	RXDATA1	0x0	R	RX Data 1 Second frame read from buffer.
15	FERR0	0x0	R	Data Framing Error 0 Set if data in buffer has a framing error. Can be the result of a break condition.
14	PERR0	0x0	R	Data Parity Error 0 Set if data in buffer has a parity error (asynchronous mode only).
13:9	<i>Reserved</i>	<i>To ensure compatibility with future devices, always write Reserved bits to their reset value, unless otherwise stated. More information in 1.2 Conventions</i>		
8:0	RXDATA0	0x0	R	RX Data 0 First frame read from buffer.

20.5.12 USART_RXDOUBLE - RX FIFO Double Data Register

Offset	Bit Position																															
0x02C	31	30	29	28	27	26	25	24	23	22	21	20	19	18	17	16	15	14	13	12	11	10	9	8	7	6	5	4	3	2	1	0
Reset																	0x0								0x0							
Access																	R								R							
Name																	RXDATA1								RXDATA0							

Bit	Name	Reset	Access	Description
31:16	<i>Reserved</i>	<i>To ensure compatibility with future devices, always write Reserved bits to their reset value, unless otherwise stated. More information in 1.2 Conventions</i>		
15:8	RXDATA1	0x0	R	RX Data 1 Second frame read from buffer.
7:0	RXDATA0	0x0	R	RX Data 0 First frame read from buffer.

20.5.13 USART_RXDATAXP - RX Buffer Data Extended Peek Register

Offset	Bit Position																															
0x030	31	30	29	28	27	26	25	24	23	22	21	20	19	18	17	16	15	14	13	12	11	10	9	8	7	6	5	4	3	2	1	0
Reset															0x0	0x0															0x0	
Access															R	R															R	
Name															FERRP	PERRP															RXDATAP	

Bit	Name	Reset	Access	Description
31:16	<i>Reserved</i>	<i>To ensure compatibility with future devices, always write Reserved bits to their reset value, unless otherwise stated. More information in 1.2 Conventions</i>		
15	FERRP	0x0	R	Data Framing Error Peek Set if data in buffer has a framing error. Can be the result of a break condition.
14	PERRP	0x0	R	Data Parity Error Peek Set if data in buffer has a parity error (asynchronous mode only).
13:9	<i>Reserved</i>	<i>To ensure compatibility with future devices, always write Reserved bits to their reset value, unless otherwise stated. More information in 1.2 Conventions</i>		
8:0	RXDATAP	0x0	R	RX Data Peek Use this register to access data read from the USART.

20.5.14 USART_RXDOUBLEXP - RX Buffer Double Data Extended Peek R...

Offset	Bit Position																																
0x034	31	30	29	28	27	26	25	24	23	22	21	20	19	18	17	16	15	14	13	12	11	10	9	8	7	6	5	4	3	2	1	0	
Reset	0x0	0x0										0x0					0x0	0x0															0x0
Access	R	R										R					R	R															R
Name	FERRP1	PERRP1										RXDATAP1					FERRP0	PERRP0															RXDATAPO

Bit	Name	Reset	Access	Description
31	FERRP1	0x0	R	Data Framing Error 1 Peek Set if data in buffer has a framing error. Can be the result of a break condition.
30	PERRP1	0x0	R	Data Parity Error 1 Peek Set if data in buffer has a parity error (asynchronous mode only).
29:25	<i>Reserved</i>	<i>To ensure compatibility with future devices, always write Reserved bits to their reset value, unless otherwise stated. More information in 1.2 Conventions</i>		
24:16	RXDATAP1	0x0	R	RX Data 1 Peek Second frame read from FIFO.
15	FERRP0	0x0	R	Data Framing Error 0 Peek Set if data in buffer has a framing error. Can be the result of a break condition.
14	PERRP0	0x0	R	Data Parity Error 0 Peek Set if data in buffer has a parity error (asynchronous mode only).
13:9	<i>Reserved</i>	<i>To ensure compatibility with future devices, always write Reserved bits to their reset value, unless otherwise stated. More information in 1.2 Conventions</i>		
8:0	RXDATAPO	0x0	R	RX Data 0 Peek First frame read from FIFO.

20.5.15 USART_TXDATAx - TX Buffer Data Extended Register

Offset	Bit Position																															
0x038	31	30	29	28	27	26	25	24	23	22	21	20	19	18	17	16	15	14	13	12	11	10	9	8	7	6	5	4	3	2	1	0
Reset																	0x0	0x0	0x0	0x0	0x0											0x0
Access																	W(nB)	W(nB)	W(nB)	W(nB)	W(nB)											W(nB)
Name																	RXENAT	TXDISAT	TXBREAK	TXTRIAT	UBRXAT											TXDATAx

Bit	Name	Reset	Access	Description
31:16	<i>Reserved</i>	<i>To ensure compatibility with future devices, always write Reserved bits to their reset value, unless otherwise stated. More information in 1.2 Conventions</i>		
15	RXENAT	0x0	W(nB)	Enable RX After Transmission Set to enable reception after transmission.
14	TXDISAT	0x0	W(nB)	Clear TXEN After Transmission Set to disable transmitter and release data bus directly after transmission.
13	TXBREAK	0x0	W(nB)	Transmit Data As Break Set to send data as a break. Recipient will see a framing error or a break condition depending on its configuration and the value of TXDATA.
12	TXTRIAT	0x0	W(nB)	Set TXTRI After Transmission Set to tristate transmitter by setting TXTRI after transmission.
11	UBRXAT	0x0	W(nB)	Unblock RX After Transmission Set to clear RXBLOCK after transmission, unblocking the receiver.
10:9	<i>Reserved</i>	<i>To ensure compatibility with future devices, always write Reserved bits to their reset value, unless otherwise stated. More information in 1.2 Conventions</i>		
8:0	TXDATAx	0x0	W(nB)	TX Data Use this register to write data to the USART. If TXEN is set, a transfer will be initiated at the first opportunity.

20.5.16 USART_TXDATA - TX Buffer Data Register

Offset	Bit Position																																
0x03C	31	30	29	28	27	26	25	24	23	22	21	20	19	18	17	16	15	14	13	12	11	10	9	8	7	6	5	4	3	2	1	0	
Reset																									TXDATA								0x0
Access																									TXDATA								W(nB)
Name																									TXDATA								

Bit	Name	Reset	Access	Description
31:8	<i>Reserved</i>	<i>To ensure compatibility with future devices, always write Reserved bits to their reset value, unless otherwise stated. More information in 1.2 Conventions</i>		
7:0	TXDATA	0x0	W(nB)	TX Data This frame will be added to TX buffer. Only 8 LSB can be written using this register. 9th bit and control bits will be cleared.

20.5.17 USART_TXDOUBLEX - TX Buffer Double Data Extended Register

Offset	Bit Position																																	
0x040	31	30	29	28	27	26	25	24	23	22	21	20	19	18	17	16	15	14	13	12	11	10	9	8	7	6	5	4	3	2	1	0		
Reset	0x0	0x0	0x0	0x0	0x0							0x0					0x0	0x0	0x0	0x0	0x0													0x0
Access	W(nB)	W(nB)	W(nB)	W(nB)	W(nB)							W(nB)					W(nB)	W(nB)	W(nB)	W(nB)	W(nB)												W(nB)	
Name	RXENAT1	TXDISAT1	TXBREAK1	TXTRIA1	UBRXAT1							TXDATA1					RXENAT0	TXDISAT0	TXBREAK0	TXTRIA0	UBRXAT0												TXDATA0	

Bit	Name	Reset	Access	Description
31	RXENAT1	0x0	W(nB)	Enable RX After Transmission Set to enable reception after transmission.
30	TXDISAT1	0x0	W(nB)	Clear TXEN After Transmission Set to disable transmitter and release data bus directly after transmission.
29	TXBREAK1	0x0	W(nB)	Transmit Data As Break Set to send data as a break. Recipient will see a framing error or a break condition depending on its configuration and the value of USARTn_TXDATA.
28	TXTRIA1	0x0	W(nB)	Set TXTRI After Transmission Set to tristate transmitter by setting TXTRI after transmission.
27	UBRXAT1	0x0	W(nB)	Unblock RX After Transmission Set clear RXBLOCK after transmission, unblocking the receiver.
26:25	<i>Reserved</i>	<i>To ensure compatibility with future devices, always write Reserved bits to their reset value, unless otherwise stated. More information in 1.2 Conventions</i>		
24:16	TXDATA1	0x0	W(nB)	TX Data Second frame to write to FIFO.
15	RXENAT0	0x0	W(nB)	Enable RX After Transmission Set to enable reception after transmission.
14	TXDISAT0	0x0	W(nB)	Clear TXEN After Transmission Set to disable transmitter and release data bus directly after transmission.
13	TXBREAK0	0x0	W(nB)	Transmit Data As Break Set to send data as a break. Recipient will see a framing error or a break condition depending on its configuration and the value of TXDATA.
12	TXTRIA0	0x0	W(nB)	Set TXTRI After Transmission Set to tristate transmitter by setting TXTRI after transmission.
11	UBRXAT0	0x0	W(nB)	Unblock RX After Transmission Set clear RXBLOCK after transmission, unblocking the receiver.
10:9	<i>Reserved</i>	<i>To ensure compatibility with future devices, always write Reserved bits to their reset value, unless otherwise stated. More information in 1.2 Conventions</i>		
8:0	TXDATA0	0x0	W(nB)	TX Data

Bit	Name	Reset	Access	Description
-----	------	-------	--------	-------------

First frame to write to buffer.

20.5.18 USART_TXDOUBLE - TX Buffer Double Data Register

Offset	Bit Position																															
0x044	31	30	29	28	27	26	25	24	23	22	21	20	19	18	17	16	15	14	13	12	11	10	9	8	7	6	5	4	3	2	1	0
Reset																	0x0								0x0							
Access																	W								W							
Name																	TXDATA1								TXDATA0							

Bit	Name	Reset	Access	Description
31:16	<i>Reserved</i>	<i>To ensure compatibility with future devices, always write Reserved bits to their reset value, unless otherwise stated. More information in 1.2 Conventions</i>		
15:8	TXDATA1	0x0	W	TX Data Second frame to write to buffer.
7:0	TXDATA0	0x0	W	TX Data First frame to write to buffer.

20.5.19 USART_IF - Interrupt Flag Register

Offset	Bit Position																																																	
0x048	31	30	29	28	27	26	25	24	23	22	21	20	19	18	17	16	15	14	13	12	11	10	9	8	7	6	5	4	3	2	1	0																		
Reset																0x0	0x0	0x0	0x0	0x0	0x0	0x0	0x0	0x0	0x0	0x0	0x0	0x0	0x0	0x0	0x0	0x0	0x0	0x0	0x0	0x0	0x0	0x0	0x0	0x0	0x0	0x0	0x0	0x0	0x0	0x0	0x0	0x0		
Access																RW	RW	RW	RW	RW	RW	RW	RW	RW	RW	RW	RW	RW	RW	RW	RW	RW	RW	RW	RW	RW	RW	RW	RW	RW	RW	RW	RW	RW	RW	RW	RW	RW	RW	
Name																TCMP2	TCMP1	TCMP0	TXIDLE	CCF	SSM	MPAF	FERR	PERR	TXUF	TXOF	RXUF	RXOF	RXFULL	RXDATAV	TXBL	TXC																		

Bit	Name	Reset	Access	Description
31:17	<i>Reserved</i>	<i>To ensure compatibility with future devices, always write Reserved bits to their reset value, unless otherwise stated. More information in 1.2 Conventions</i>		
16	TCMP2	0x0	RW	Timer comparator 2 Interrupt Flag Set when the timer reaches the comparator 2 value, TCMP2.
15	TCMP1	0x0	RW	Timer comparator 1 Interrupt Flag Set when the timer reaches the comparator 1 value, TCMP1.
14	TCMP0	0x0	RW	Timer comparator 0 Interrupt Flag Set when the Timer reaches the comparator 0 value, TCMP0.
13	TXIDLE	0x0	RW	TX Idle Interrupt Flag Set when TX goes idle. At this point, transmission has ended
12	CCF	0x0	RW	Collision Check Fail Interrupt Flag Set when a collision check notices an error in the transmitted data.
11	SSM	0x0	RW	Chip-Select In Main Mode Interrupt Flag Set when the chip select is pulled active when in main interface mode.
10	MPAF	0x0	RW	Multi-Processor Address Frame Interrupt Set when a multi-processor address frame is detected.
9	FERR	0x0	RW	Framing Error Interrupt Flag Set when a frame with a framing error is received while RXBLOCK is cleared.
8	PERR	0x0	RW	Parity Error Interrupt Flag Set when a frame with a parity error (asynchronous mode only) is received while RXBLOCK is cleared.
7	TXUF	0x0	RW	TX Underflow Interrupt Flag Set when operating as a synchronous secondary, no data is available in the transmit buffer when the main interface starts transmission of a new frame.
6	TXOF	0x0	RW	TX Overflow Interrupt Flag Set when a write is done to the transmit buffer while it is full. The data already in the transmit buffer is preserved.
5	RXUF	0x0	RW	RX Underflow Interrupt Flag Set when trying to read from the receive buffer when it is empty.
4	RXOF	0x0	RW	RX Overflow Interrupt Flag Set when data is incoming while the receive shift register is full. The data previously in the shift register is lost.

Bit	Name	Reset	Access	Description
3	RXFULL	0x0	RW	RX Buffer Full Interrupt Flag Set when the receive buffer becomes full.
2	RXDATAV	0x0	RW	RX Data Valid Interrupt Flag Set when data becomes available in the receive buffer.
1	TXBL	0x1	RW	TX Buffer Level Interrupt Flag Set when buffer becomes empty if buffer level is set to 0x0, or when the number of empty TX buffer elements equals specified buffer level.
0	TXC	0x0	RW	TX Complete Interrupt Flag This interrupt is set after a transmission when both the TX buffer and shift register are empty.

20.5.20 USART_IEN - Interrupt Enable Register

Offset	Bit Position																																															
0x04C	31	30	29	28	27	26	25	24	23	22	21	20	19	18	17	16	15	14	13	12	11	10	9	8	7	6	5	4	3	2	1	0																
Reset																0x0	0x0	0x0	0x0	0x0	0x0	0x0	0x0	0x0	0x0	0x0	0x0	0x0	0x0	0x0	0x0	0x0	0x0	0x0	0x0	0x0	0x0	0x0	0x0	0x0	0x0	0x0	0x0	0x0	0x0	0x0	0x0	
Access																RW	RW	RW	RW	RW	RW	RW	RW	RW	RW	RW	RW	RW	RW	RW	RW	RW	RW	RW	RW	RW	RW	RW	RW	RW	RW	RW	RW	RW	RW	RW	RW	RW
Name																TCMP2	TCMP1	TCMP0	TXIDLE	CCF	SSM	MPAF	FERR	PERR	TXUF	TXOF	RXUF	RXOF	RXFULL	RXDATAV	TXBL	TXC																

Bit	Name	Reset	Access	Description
31:17	<i>Reserved</i>	<i>To ensure compatibility with future devices, always write Reserved bits to their reset value, unless otherwise stated. More information in 1.2 Conventions</i>		
16	TCMP2	0x0	RW	Timer comparator 2 Interrupt Enable Set when the timer reaches the comparator 2 value, TCMP2.
15	TCMP1	0x0	RW	Timer comparator 1 Interrupt Enable Set when the timer reaches the comparator 1 value, TCMP1.
14	TCMP0	0x0	RW	Timer comparator 0 Interrupt Enable Set when the Timer reaches the comparator 0 value, TCMP0.
13	TXIDLE	0x0	RW	TX Idle Interrupt Enable Set when TX goes idle. At this point, transmission has ended
12	CCF	0x0	RW	Collision Check Fail Interrupt Enable Set when a collision check notices an error in the transmitted data.
11	SSM	0x0	RW	Chip-Select In Main Mode Interrupt Flag Set when the chip select is pulled active when in main interface mode.
10	MPAF	0x0	RW	Multi-Processor Address Frame Interrupt Set when a multi-processor address frame is detected.
9	FERR	0x0	RW	Framing Error Interrupt Enable Set when a frame with a framing error is received while RXBLOCK is cleared.
8	PERR	0x0	RW	Parity Error Interrupt Enable Set when a frame with a parity error (asynchronous mode only) is received while RXBLOCK is cleared.
7	TXUF	0x0	RW	TX Underflow Interrupt Enable Set when operating as a synchronous secondary, no data is available in the transmit buffer when the main interface starts transmission of a new frame.
6	TXOF	0x0	RW	TX Overflow Interrupt Enable Set when a write is done to the transmit buffer while it is full. The data already in the transmit buffer is preserved.
5	RXUF	0x0	RW	RX Underflow Interrupt Enable Set when trying to read from the receive buffer when it is empty.
4	RXOF	0x0	RW	RX Overflow Interrupt Enable Set when data is incoming while the receive shift register is full. The data previously in the shift register is lost.

Bit	Name	Reset	Access	Description
3	RXFULL	0x0	RW	RX Buffer Full Interrupt Enable Set when the receive buffer becomes full.
2	RXDATAV	0x0	RW	RX Data Valid Interrupt Enable Set when data becomes available in the receive buffer.
1	TXBL	0x0	RW	TX Buffer Level Interrupt Enable Set when buffer becomes empty if buffer level is set to 0x0, or when the number of empty TX buffer elements equals specified buffer level.
0	TXC	0x0	RW	TX Complete Interrupt Enable This interrupt is set after a transmission when both the TX buffer and shift register are empty.

20.5.21 USART_IRCTRL - IrDA Control Register

Offset	Bit Position																															
0x050	31	30	29	28	27	26	25	24	23	22	21	20	19	18	17	16	15	14	13	12	11	10	9	8	7	6	5	4	3	2	1	0
Reset																												0x0	0x0	0x0		
Access																												RW	RW	RW		
Name																												IRFILT	IRPW	IREN		

Bit	Name	Reset	Access	Description															
31:4	<i>Reserved</i>	<i>To ensure compatibility with future devices, always write Reserved bits to their reset value, unless otherwise stated. More information in 1.2 Conventions</i>																	
3	IRFILT	0x0	RW	IrDA RX Filter Set to enable filter on IrDA demodulator. <table border="1"> <thead> <tr> <th>Value</th> <th>Mode</th> <th>Description</th> </tr> </thead> <tbody> <tr> <td>0</td> <td>DISABLE</td> <td>No filter enabled</td> </tr> <tr> <td>1</td> <td>ENABLE</td> <td>Filter enabled. IrDA pulse must be high for at least 5 consecutive clock cycles to be detected</td> </tr> </tbody> </table>	Value	Mode	Description	0	DISABLE	No filter enabled	1	ENABLE	Filter enabled. IrDA pulse must be high for at least 5 consecutive clock cycles to be detected						
Value	Mode	Description																	
0	DISABLE	No filter enabled																	
1	ENABLE	Filter enabled. IrDA pulse must be high for at least 5 consecutive clock cycles to be detected																	
2:1	IRPW	0x0	RW	IrDA TX Pulse Width Configure the pulse width generated by the IrDA modulator as a fraction of the configured USART bit period. <table border="1"> <thead> <tr> <th>Value</th> <th>Mode</th> <th>Description</th> </tr> </thead> <tbody> <tr> <td>0</td> <td>ONE</td> <td>IrDA pulse width is 1/16 for OVS=0 and 1/8 for OVS=1</td> </tr> <tr> <td>1</td> <td>TWO</td> <td>IrDA pulse width is 2/16 for OVS=0 and 2/8 for OVS=1</td> </tr> <tr> <td>2</td> <td>THREE</td> <td>IrDA pulse width is 3/16 for OVS=0 and 3/8 for OVS=1</td> </tr> <tr> <td>3</td> <td>FOUR</td> <td>IrDA pulse width is 4/16 for OVS=0 and 4/8 for OVS=1</td> </tr> </tbody> </table>	Value	Mode	Description	0	ONE	IrDA pulse width is 1/16 for OVS=0 and 1/8 for OVS=1	1	TWO	IrDA pulse width is 2/16 for OVS=0 and 2/8 for OVS=1	2	THREE	IrDA pulse width is 3/16 for OVS=0 and 3/8 for OVS=1	3	FOUR	IrDA pulse width is 4/16 for OVS=0 and 4/8 for OVS=1
Value	Mode	Description																	
0	ONE	IrDA pulse width is 1/16 for OVS=0 and 1/8 for OVS=1																	
1	TWO	IrDA pulse width is 2/16 for OVS=0 and 2/8 for OVS=1																	
2	THREE	IrDA pulse width is 3/16 for OVS=0 and 3/8 for OVS=1																	
3	FOUR	IrDA pulse width is 4/16 for OVS=0 and 4/8 for OVS=1																	
0	IREN	0x0	RW	Enable IrDA Module Enable IrDA module and rout USART signals through it.															

20.5.22 USART_I2SCTRL - I2S Control Register

Offset	Bit Position																																		
0x054	31	30	29	28	27	26	25	24	23	22	21	20	19	18	17	16	15	14	13	12	11	10	9	8	7	6	5	4	3	2	1	0			
Reset																						0x0				0x0		0x0		0x0		0x0		0x0	
Access																						RW				RW		RW		RW		RW		RW	
Name																						FORMAT				DELAY		DMASPLIT		JUSTIFY		MONO		EN	

Bit	Name	Reset	Access	Description
31:11	<i>Reserved</i>	<i>To ensure compatibility with future devices, always write Reserved bits to their reset value, unless otherwise stated. More information in 1.2 Conventions</i>		
10:8	FORMAT	0x0	RW	I2S Word Format Configure the data-width used internally for I2S data
	Value	Mode	Description	
	0	W32D32	32-bit word, 32-bit data	
	1	W32D24M	32-bit word, 32-bit data with 8 lsb masked	
	2	W32D24	32-bit word, 24-bit data	
	3	W32D16	32-bit word, 16-bit data	
	4	W32D8	32-bit word, 8-bit data	
	5	W16D16	16-bit word, 16-bit data	
	6	W16D8	16-bit word, 8-bit data	
	7	W8D8	8-bit word, 8-bit data	
7:5	<i>Reserved</i>	<i>To ensure compatibility with future devices, always write Reserved bits to their reset value, unless otherwise stated. More information in 1.2 Conventions</i>		
4	DELAY	0x0	RW	Delay on I2S data Set to add a one-cycle delay between a transition on the word-clock and the start of the I2S word. Should be set for standard I2S format
3	DMASPLIT	0x0	RW	Separate DMA Request For Left/Right Data When set DMA requests for right-channel data are put on the TXBLRIGHT and RXDATAVRIGHT DMA requests.
2	JUSTIFY	0x0	RW	Justification of I2S Data Determines whether the I2S data is left or right justified
	Value	Mode	Description	
	0	LEFT	Data is left-justified	
	1	RIGHT	Data is right-justified	
1	MONO	0x0	RW	Stereo or Mono Switch between stereo and mono mode. Set for mono
0	EN	0x0	RW	Enable I2S Mode

Bit	Name	Reset	Access	Description
				Set the U(S)ART in I2S mode.



20.5.23 USART_TIMING - Timing Register

Offset	Bit Position																																	
0x058	31	30	29	28	27	26	25	24	23	22	21	20	19	18	17	16	15	14	13	12	11	10	9	8	7	6	5	4	3	2	1	0		
Reset			0x0			0x0				0x0					0x0																			
Access			RW			RW				RW					RW																			
Name			CSHOLD			ICS				CSSETUP					TXDELAY																			

Bit	Name	Reset	Access	Description																											
31	<i>Reserved</i>			<i>To ensure compatibility with future devices, always write Reserved bits to their reset value, unless otherwise stated. More information in 1.2 Conventions</i>																											
30:28	CSHOLD	0x0	RW	Chip Select Hold Chip Select will be asserted after the end of frame transmission. When using TCMPn, normally set TIMECMPn_TSTART to DISABLE to stop general timer and to prevent unwanted interrupts. <table border="1"> <thead> <tr> <th>Value</th> <th>Mode</th> <th>Description</th> </tr> </thead> <tbody> <tr> <td>0</td> <td>ZERO</td> <td>Disable CS being asserted after the end of transmission</td> </tr> <tr> <td>1</td> <td>ONE</td> <td>CS is asserted for 1 baud-times after the end of transmission</td> </tr> <tr> <td>2</td> <td>TWO</td> <td>CS is asserted for 2 baud-times after the end of transmission</td> </tr> <tr> <td>3</td> <td>THREE</td> <td>CS is asserted for 3 baud-times after the end of transmission</td> </tr> <tr> <td>4</td> <td>SEVEN</td> <td>CS is asserted for 7 baud-times after the end of transmission</td> </tr> <tr> <td>5</td> <td>TCMP0</td> <td>CS is asserted after the end of transmission for TCMPVAL0 baud-times</td> </tr> <tr> <td>6</td> <td>TCMP1</td> <td>CS is asserted after the end of transmission for TCMPVAL1 baud-times</td> </tr> <tr> <td>7</td> <td>TCMP2</td> <td>CS is asserted after the end of transmission for TCMPVAL2 baud-times</td> </tr> </tbody> </table>	Value	Mode	Description	0	ZERO	Disable CS being asserted after the end of transmission	1	ONE	CS is asserted for 1 baud-times after the end of transmission	2	TWO	CS is asserted for 2 baud-times after the end of transmission	3	THREE	CS is asserted for 3 baud-times after the end of transmission	4	SEVEN	CS is asserted for 7 baud-times after the end of transmission	5	TCMP0	CS is asserted after the end of transmission for TCMPVAL0 baud-times	6	TCMP1	CS is asserted after the end of transmission for TCMPVAL1 baud-times	7	TCMP2	CS is asserted after the end of transmission for TCMPVAL2 baud-times
Value	Mode	Description																													
0	ZERO	Disable CS being asserted after the end of transmission																													
1	ONE	CS is asserted for 1 baud-times after the end of transmission																													
2	TWO	CS is asserted for 2 baud-times after the end of transmission																													
3	THREE	CS is asserted for 3 baud-times after the end of transmission																													
4	SEVEN	CS is asserted for 7 baud-times after the end of transmission																													
5	TCMP0	CS is asserted after the end of transmission for TCMPVAL0 baud-times																													
6	TCMP1	CS is asserted after the end of transmission for TCMPVAL1 baud-times																													
7	TCMP2	CS is asserted after the end of transmission for TCMPVAL2 baud-times																													
27	<i>Reserved</i>			<i>To ensure compatibility with future devices, always write Reserved bits to their reset value, unless otherwise stated. More information in 1.2 Conventions</i>																											
26:24	ICS	0x0	RW	Inter-character spacing Inter-character spacing after each TX frame while the TX buffer is not empty. When using USART_TIMECMPn, normally set TSTART to DISABLE to stop general timer and to prevent unwanted interrupts. <table border="1"> <thead> <tr> <th>Value</th> <th>Mode</th> <th>Description</th> </tr> </thead> <tbody> <tr> <td>0</td> <td>ZERO</td> <td>There is no space between charcters</td> </tr> <tr> <td>1</td> <td>ONE</td> <td>Create a space of 1 baud-times before start of transmission</td> </tr> <tr> <td>2</td> <td>TWO</td> <td>Create a space of 2 baud-times before start of transmission</td> </tr> <tr> <td>3</td> <td>THREE</td> <td>Create a space of 3 baud-times before start of transmission</td> </tr> <tr> <td>4</td> <td>SEVEN</td> <td>Create a space of 7 baud-times before start of transmission</td> </tr> <tr> <td>5</td> <td>TCMP0</td> <td>Create a space of before the start of transmission for TCMPVAL0 baud-times</td> </tr> </tbody> </table>	Value	Mode	Description	0	ZERO	There is no space between charcters	1	ONE	Create a space of 1 baud-times before start of transmission	2	TWO	Create a space of 2 baud-times before start of transmission	3	THREE	Create a space of 3 baud-times before start of transmission	4	SEVEN	Create a space of 7 baud-times before start of transmission	5	TCMP0	Create a space of before the start of transmission for TCMPVAL0 baud-times						
Value	Mode	Description																													
0	ZERO	There is no space between charcters																													
1	ONE	Create a space of 1 baud-times before start of transmission																													
2	TWO	Create a space of 2 baud-times before start of transmission																													
3	THREE	Create a space of 3 baud-times before start of transmission																													
4	SEVEN	Create a space of 7 baud-times before start of transmission																													
5	TCMP0	Create a space of before the start of transmission for TCMPVAL0 baud-times																													

Bit	Name	Reset	Access	Description
6		TCMP1		Create a space of before the start of transmission for TCMPVAL1 baud-times
7		TCMP2		Create a space of before the start of transmission for TCMPVAL2 baud-times
23	<i>Reserved</i>	<i>To ensure compatibility with future devices, always write Reserved bits to their reset value, unless otherwise stated. More information in 1.2 Conventions</i>		
22:20	CSSETUP	0x0	RW	Chip Select Setup Chip Select will be asserted before the start of frame transmission. When using USART_TIMECMPn, normally set TSTART to DISABLE to stop general timer and to prevent unwanted interrupts.
	Value	Mode	Description	
	0	ZERO	CS is not asserted before start of transmission	
	1	ONE	CS is asserted for 1 baud-times before start of transmission	
	2	TWO	CS is asserted for 2 baud-times before start of transmission	
	3	THREE	CS is asserted for 3 baud-times before start of transmission	
	4	SEVEN	CS is asserted for 7 baud-times before start of transmission	
	5	TCMP0	CS is asserted before the start of transmission for TCMPVAL0 baud-times	
	6	TCMP1	CS is asserted before the start of transmission for TCMPVAL1 baud-times	
	7	TCMP2	CS is asserted before the start of transmission for TCMPVAL2 baud-times	
19	<i>Reserved</i>	<i>To ensure compatibility with future devices, always write Reserved bits to their reset value, unless otherwise stated. More information in 1.2 Conventions</i>		
18:16	TXDELAY	0x0	RW	TX frame start delay Number of baud-times to delay the start of frame transmission. When using USART_TIMECMPn, normally set TSTART to DISABLE to stop general timer and to prevent unwanted interrupts.
	Value	Mode	Description	
	0	DISABLE	Disable - TXDELAY in USARTn_CTRL can be used for legacy	
	1	ONE	Start of transmission is delayed for 1 baud-times	
	2	TWO	Start of transmission is delayed for 2 baud-times	
	3	THREE	Start of transmission is delayed for 3 baud-times	
	4	SEVEN	Start of transmission is delayed for 7 baud-times	
	5	TCMP0	Start of transmission is delayed for TCMPVAL0 baud-times	
	6	TCMP1	Start of transmission is delayed for TCMPVAL1 baud-times	
	7	TCMP2	Start of transmission is delayed for TCMPVAL2 baud-times	
15:0	<i>Reserved</i>	<i>To ensure compatibility with future devices, always write Reserved bits to their reset value, unless otherwise stated. More information in 1.2 Conventions</i>		

20.5.24 USART_CTRLX - Control Register Extended

Offset	Bit Position																																			
0x05C	31	30	29	28	27	26	25	24	23	22	21	20	19	18	17	16	15	14	13	12	11	10	9	8	7	6	5	4	3	2	1	0				
Reset																	0x0											0x0					0x0	0x0	0x0	0x0
Access																	RW											RW					RW	RW	RW	RW
Name																	CLKPRSEN											RXPRSEN					RTSINV	CTSSEN	CTSINV	DBGHALT

Bit	Name	Reset	Access	Description
31:16	Reserved	To ensure compatibility with future devices, always write Reserved bits to their reset value, unless otherwise stated. More information in 1.2 Conventions		
15	CLKPRSEN	0x0	RW	PRS CLK Enable When set, the PRS channel selected as input to CLK.
14:8	Reserved	To ensure compatibility with future devices, always write Reserved bits to their reset value, unless otherwise stated. More information in 1.2 Conventions		
7	RXPRSEN	0x0	RW	PRS RX Enable When set, the PRS channel selected as input to RX.
6:4	Reserved	To ensure compatibility with future devices, always write Reserved bits to their reset value, unless otherwise stated. More information in 1.2 Conventions		
3	RTSINV	0x0	RW	RTS Pin Inversion When set, the RTS pin polarity is inverted.
	Value	Mode	Description	
	0	DISABLE	The USn_RTS pin is low true	
	1	ENABLE	The USn_RTS pin is high true	
2	CTSSEN	0x0	RW	CTS Function enabled When set, frames in the TXBUF _n will not be sent until link partner asserts CTS. Any data in the TX shift register will continue transmitting, the next TXBUF _n data will not load into the TX shift register
	Value	Mode	Description	
	0	DISABLE	Ignore CTS	
	1	ENABLE	Stop transmitting when CTS is negated	
1	CTSINV	0x0	RW	CTS Pin Inversion When set, the CTS pin polarity is inverted.
	Value	Mode	Description	
	0	DISABLE	The USn_CTS pin is low true	
	1	ENABLE	The USn_CTS pin is high true	
0	DBGHALT	0x0	RW	Debug halt

Bit	Name	Reset	Access	Description
.				
	Value	Mode		Description
	0	DISABLE		Continue to transmit until TX buffer is empty
	1	ENABLE		Negate RTS to stop link partner's transmission during debug HALT. NOTE** The core clock should be equal to or faster than the peripheral clock; otherwise, each single step could transmit multiple frames instead of just transmitting one frame.

20.5.25 USART_TIMECMP0 - Timer Compare 0

Offset	Bit Position																															
0x060	31	30	29	28	27	26	25	24	23	22	21	20	19	18	17	16	15	14	13	12	11	10	9	8	7	6	5	4	3	2	1	0
Reset								0x0		0x0				0x0															0x0			
Access								RW		RW				RW															RW			
Name								RESTARTEN		TSTOP				TSTART															TCMPVAL			

Bit	Name	Reset	Access	Description
31:25	<i>Reserved</i>	<i>To ensure compatibility with future devices, always write Reserved bits to their reset value, unless otherwise stated. More information in 1.2 Conventions</i>		
24	RESTARTEN	0x0	RW	Restart Timer on TCMP0 Each TCMP0 event will reset and restart the timer
	Value	Mode		Description
	0	DISABLE		Disable the timer restarting on TCMP0
	1	ENABLE		Enable the timer restarting on TCMP0
23	<i>Reserved</i>	<i>To ensure compatibility with future devices, always write Reserved bits to their reset value, unless otherwise stated. More information in 1.2 Conventions</i>		
22:20	TSTOP	0x0	RW	Source used to disable comparator 0 Select the source which disables comparator 0
	Value	Mode		Description
	0	TCMP0		Comparator 0 is disabled when the counter equals TCMPVAL and triggers a TCMP0 event
	1	TXST		Comparator 0 is disabled at TX start TX Engine
	2	RXACT		Comparator 0 is disabled on RX going going Active (default: low)
	3	RXACTN		Comparator 0 is disabled on RX going Inactive
19	<i>Reserved</i>	<i>To ensure compatibility with future devices, always write Reserved bits to their reset value, unless otherwise stated. More information in 1.2 Conventions</i>		
18:16	TSTART	0x0	RW	Timer start source Source used to start comparator 0 and timer
	Value	Mode		Description
	0	DISABLE		Comparator 0 is disabled
	1	TXEOF		Comparator 0 and timer are started at TX end of frame
	2	TXC		Comparator 0 and timer are started at TX Complete
	3	RXACT		Comparator 0 and timer are started at RX going going Active (default: low)

Bit	Name	Reset	Access	Description
4		RXEOF		Comparator 0 and timer are started at RX end of frame
15:8	<i>Reserved</i>	<i>To ensure compatibility with future devices, always write Reserved bits to their reset value, unless otherwise stated. More information in 1.2 Conventions</i>		
7:0	TCMPVAL	0x0	RW	Timer comparator 0. When the timer equals TCMPVAL, this signals a TCMP0 event and sets the TCMP0 flag. This event can also be used to enable various USART functionality. A value of 0x00 represents 256 baud times.

20.5.26 USART_TIMECMP1 - Timer Compare 1

Offset	Bit Position																															
0x064	31	30	29	28	27	26	25	24	23	22	21	20	19	18	17	16	15	14	13	12	11	10	9	8	7	6	5	4	3	2	1	0
Reset								0x0		0x0				0x0															0x0			
Access								RW		RW				RW															RW			
Name								RESTARTEN		TSTOP				TSTART															TCMPVAL			

Bit	Name	Reset	Access	Description
31:25	<i>Reserved</i>	<i>To ensure compatibility with future devices, always write Reserved bits to their reset value, unless otherwise stated. More information in 1.2 Conventions</i>		
24	RESTARTEN	0x0	RW	Restart Timer on TCMP1 Each TCMP1 event will reset and restart the timer
	Value	Mode		Description
	0	DISABLE		Disable the timer restarting on TCMP1
	1	ENABLE		Enable the timer restarting on TCMP1
23	<i>Reserved</i>	<i>To ensure compatibility with future devices, always write Reserved bits to their reset value, unless otherwise stated. More information in 1.2 Conventions</i>		
22:20	TSTOP	0x0	RW	Source used to disable comparator 1 Select the source which disables comparator 1
	Value	Mode		Description
	0	TCMP1		Comparator 1 is disabled when the counter equals TCMPVAL and triggers a TCMP1 event
	1	TXST		Comparator 1 is disabled at TX start TX Engine
	2	RXACT		Comparator 1 is disabled on RX going going Active (default: low)
	3	RXACTN		Comparator 1 is disabled on RX going Inactive
19	<i>Reserved</i>	<i>To ensure compatibility with future devices, always write Reserved bits to their reset value, unless otherwise stated. More information in 1.2 Conventions</i>		
18:16	TSTART	0x0	RW	Timer start source Source used to start comparator 1 and timer
	Value	Mode		Description
	0	DISABLE		Comparator 1 is disabled
	1	TXEOF		Comparator 1 and timer are started at TX end of frame
	2	TXC		Comparator 1 and timer are started at TX Complete
	3	RXACT		Comparator 1 and timer are started at RX going going Active (default: low)

Bit	Name	Reset	Access	Description
4		RXEOF		Comparator 1 and timer are started at RX end of frame
15:8	<i>Reserved</i>	<i>To ensure compatibility with future devices, always write Reserved bits to their reset value, unless otherwise stated. More information in 1.2 Conventions</i>		
7:0	TCMPVAL	0x0	RW	Timer comparator 1. When the timer equals TCMPVAL, this signals a TCMP1 event and sets the TCMP1 flag. This event can also be used to enable various USART functionality. A value of 0x00 represents 256 baud times.

20.5.27 USART_TIMECMP2 - Timer Compare 2

Offset	Bit Position																															
0x068	31	30	29	28	27	26	25	24	23	22	21	20	19	18	17	16	15	14	13	12	11	10	9	8	7	6	5	4	3	2	1	0
Reset								0x0			0x0			0x0											0x0							
Access								RW			RW			RW											RW							
Name								RESTARTEN			TSTOP			TSTART											TCMPVAL							

Bit	Name	Reset	Access	Description
31:25	Reserved	To ensure compatibility with future devices, always write Reserved bits to their reset value, unless otherwise stated. More information in 1.2 Conventions		
24	RESTARTEN	0x0	RW	Restart Timer on TCMP2 Each TCMP2 event will reset and restart the timer
	Value	Mode		Description
	0	DISABLE		Disable the timer restarting on TCMP2
	1	ENABLE		Enable the timer restarting on TCMP2
23	Reserved	To ensure compatibility with future devices, always write Reserved bits to their reset value, unless otherwise stated. More information in 1.2 Conventions		
22:20	TSTOP	0x0	RW	Source used to disable comparator 2 Select the source which disables comparator 2
	Value	Mode		Description
	0	TCMP2		Comparator 2 is disabled when the counter equals TCMPVAL and triggers a TCMP2 event
	1	TXST		Comparator 2 is disabled at TX start TX Engine
	2	RXACT		Comparator 2 is disabled on RX going going Active (default: low)
	3	RXACTN		Comparator 2 is disabled on RX going Inactive
19	Reserved	To ensure compatibility with future devices, always write Reserved bits to their reset value, unless otherwise stated. More information in 1.2 Conventions		
18:16	TSTART	0x0	RW	Timer start source Source used to start comparator 2 and timer
	Value	Mode		Description
	0	DISABLE		Comparator 2 is disabled
	1	TXEOF		Comparator 2 and timer are started at TX end of frame
	2	TXC		Comparator 2 and timer are started at TX Complete
	3	RXACT		Comparator 2 and timer are started at RX going going Active (default: low)

Bit	Name	Reset	Access	Description
4		RXEOF		Comparator 2 and timer are started at RX end of frame
15:8	<i>Reserved</i>	<i>To ensure compatibility with future devices, always write Reserved bits to their reset value, unless otherwise stated. More information in 1.2 Conventions</i>		
7:0	TCMPVAL	0x0	RW	Timer comparator 2. When the timer equals TCMPVAL, this signals a TCMP2 event and sets the TCMP2 flag. This event can also be used to enable various USART functionality. A value of 0x00 represents 256 baud times.

21. EUSART - Universal Synchronous Asynchronous Receiver/Transmitter

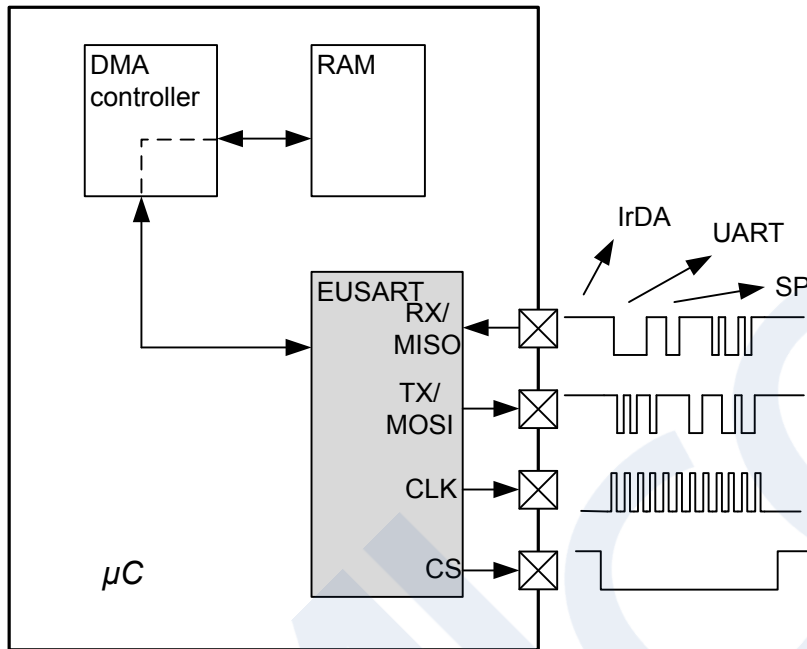
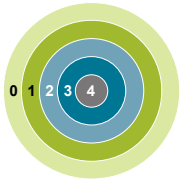

Quick Facts

What?

The EUSART handles high-speed UART, SPI-bus, and IrDA communication.

Why?

Serial communication is frequently used in embedded systems and the EUSART allows efficient communication with a wide range of external devices.

How?

The EUSART has a wide selection of operating modes, frame formats and baud rates. The multi-processor mode allows the EUSART to remain idle when not addressed. 16-deep FIFOs and DMA support makes high data-rates possible with minimal CPU intervention and it is possible to transmit and receive large frames while the MCU remains in EM1 Sleep.

21.1 Introduction

The Enhanced Universal Synchronous Asynchronous serial Receiver and Transmitter (EUSART) is a very flexible serial I/O module. It supports full duplex asynchronous UART communication as well as SPI, MicroWire. It can also interface with IrDA devices.

21.2 Features

- Asynchronous (UART) and synchronous (SPI) communication
- Full duplex and half duplex
- Separate TX/RX enable
- Separate receive / transmit 16 deep FIFOs, with additional separate shift registers
- Can operate using HF clock or LF clock (UART only)
- Programmable baud rate, generated as a fractional division from the peripheral clock ($\text{HFPERCLK}_{\text{EUSARTn}}$)
- Max bit-rate
 - Main SPI mode: 20 MHz
 - Secondary SPI mode: 10 MHz
 - UART mode, HF peripheral clock rate/16, 8, 6, or 4
 - UART mode, 32 KHz LF peripheral clock: 9600 (oversampling not supported with LF operation)
- Supports transmission and reception in EM0 (also EM1 and EM2 in certain modes) with
 - Full DMA support
 - UART mode, specified start-frame can start reception automatically
- UART mode, capable of sleep-mode wake-up on received frame (EM2 Capable instance only)
 - Either wake-up on any received byte or
 - Wake up only on specified start and signal frames
- SPI mode, capable of sleep-mode wake-up on received frame (EM2/3 Capable instance only)
 - Either wake-up on CS active or
 - Wake up on Receive FIFO level matching Watermark Level Setting
- Asynchronous mode supports
 - Configurable number of data bits 7-9 (plus the parity bit, if enabled)
 - HW parity bit generation and check
 - Majority vote baud-reception
 - False start-bit detection
 - Break generation/detection
 - Multi-processor mode
 - Configurable number of stop bits in asynchronous mode:
 - HF clock EM0/1 operation: 0.5, 1, 1.5, 2
 - LF clock operation: 1, 2
 - HW collision detection
 - IrDA support
 - HF clock EM0/1 operation: IrDA modulator
 - LF clock operation: Pulse extender, RX-only
 - Hardware Flow Control
 - Automatic Baud Rate Detection
- Synchronous mode supports
 - Configurable number of data bits 8-16
 - All 4 SPI clock polarity/phase configurations
 - Main and Secondary interface modes
- Data can be transmitted LSB first or MSB first
- Separate interrupt vectors for receive and transmit interrupts
- Loopback mode
 - Half duplex communication
 - Communication debugging
- PRS RX input
- DMA Support
- EM2 operation with LF clock (EM2/3 Capable instance only), wakeup to EM1 for DMA interaction
- Async mode Automatic Baud Rate Detection operating with HF clock in EM0/1

21.3 Functional Description

An overview of the EUSART module is shown in [Figure 21.1 EUSART Overview](#) on page 637.

This section describes all possible EUSART features. Please refer to the Device Datasheet to see what features a specific EUSART instance supports.

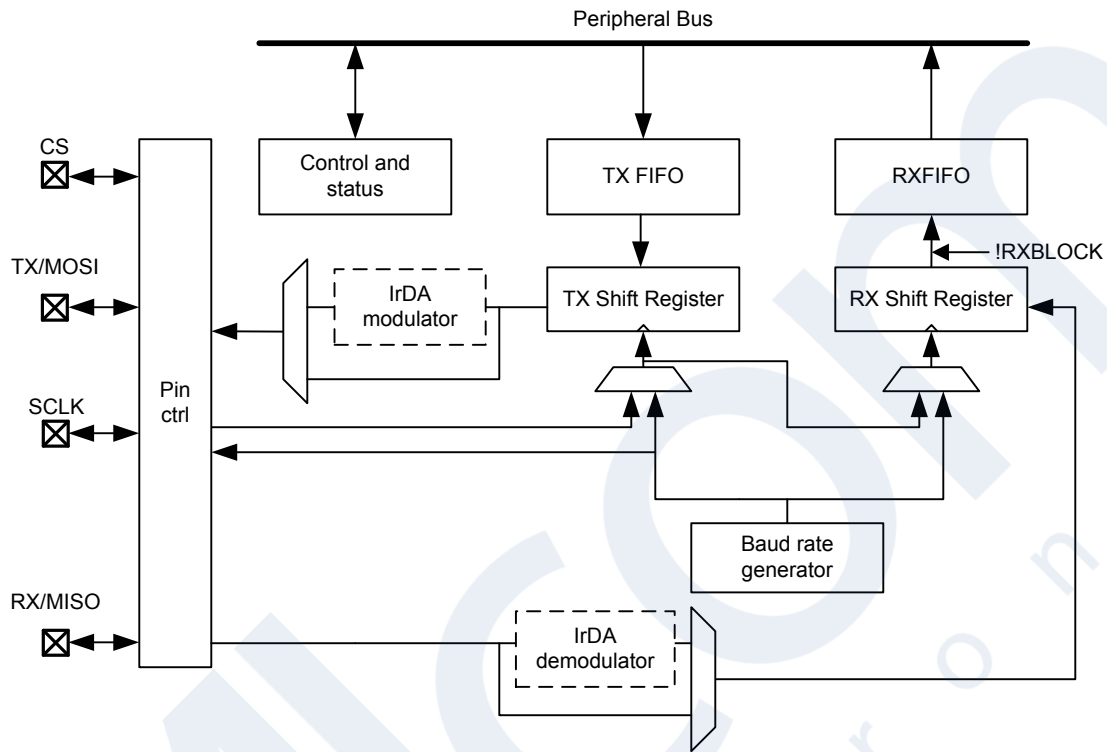

Figure 21.1. EUSART Overview

21.3.1 Modes of Operation

The EUSART operates in either asynchronous or synchronous mode.

In synchronous mode, a separate clock signal is transmitted with the data. This clock signal is generated by the main interface on the bus, and both the main and secondary devices sample and transmit data according to this clock. Both main and secondary interface modes are supported by the EUSART. The synchronous communication mode is compatible with the Serial Peripheral Interface Bus (SPI) standard.

In asynchronous mode, no separate clock signal is transmitted with the data on the bus. The EUSART receiver thus has to determine where to sample the data on the bus from the actual data. To make this possible, additional synchronization bits are added to the data when operating in asynchronous mode, resulting in a slight overhead.

Asynchronous or synchronous mode can be selected by configuring SYNC in EUSARTn_CFG0. The options are listed with supported protocols in [Table 21.1 EUSART Asynchronous vs. Synchronous Mode on page 638](#). Full duplex and half duplex communication is supported in both asynchronous and synchronous mode.

Table 21.1. EUSART Asynchronous vs. Synchronous Mode

SYNC	Communication Mode	Supported Protocols
0	Asynchronous	RS-232, IrDA
1	Synchronous	SPI, MicroWire

[Table 21.2 EUSART Pin Usage on page 638](#) explains the functionality of the different EUSART pins when the EUSART operates in different modes. Pin functionality enclosed in square brackets is optional, and depends on additional configuration parameters. LOOPBK and MASTER are discussed in [21.3.2.7 Local Loopback](#) and [21.3.3.3 Main SPI Interface Mode \(Clock Driver\)](#) respectively.

Table 21.2. EUSART Pin Usage

SYNC	LOOPBK	MASTER	Pin Functionality			
			TX (MOSI)	RX (MISO)	CLK	CS
0	0	x	Data out	Data in	-	-
0	1	x	Data out/in	-	-	-
1	0	0	Data in	Data out	Clock in	Secondary select
1	0	1	Data out	Data in	Clock out	[Auto secondary select]
1	1	0	Data out/in	-	Clock in	Secondary select
1	1	1	Data out/in	-	Clock out	[Auto secondary select]

21.3.2 Asynchronous Operation

EUSART can operate in asynchronous mode when EUSARTn_CFG0.SYNC is set to 0.

EUSART0 may operate as either a high-speed peripheral running from a high-frequency clock source (HF mode, available in EM0 and EM1), or as a low-energy peripheral operating from a low-frequency clock source (LF mode, available in EM0, EM1, or EM2). EUSART0 operates in HF mode when the EUSART0CLK clock selected in CMU_EUSART0CLKCTRL_CLKSEL is EM01GRPACLK or HFRCOEM23. EUSART0 operates in LF mode when the selected clock is LFXO or LFRCO. Baud rate generation differs between these two modes, and there are certain operational restrictions in LF mode discussed in this chapter. It is not generally useful to switch between modes on-the-fly in a single application.

Other EUSART instances operate only as a high-speed peripheral running from the EM01GRPCCLK selected using CMU_EM01GRPCCLKCTRL_CLKSEL.

21.3.2.1 Frame Format

The frame format used in asynchronous mode consists of a set of data bits in addition to bits for synchronization and optionally a parity bit for error checking. A frame starts with one start-bit (S), where the line is driven low for one bit-period. This signals the start of a frame, and is used for synchronization. Following the start bit are 7 to 9 data bits and an optional parity bit. Finally, a number of stop-bits, where the line is driven high that indicates the end of the frame. An example frame is shown in [Figure 21.2 Frame Format on page 639](#).

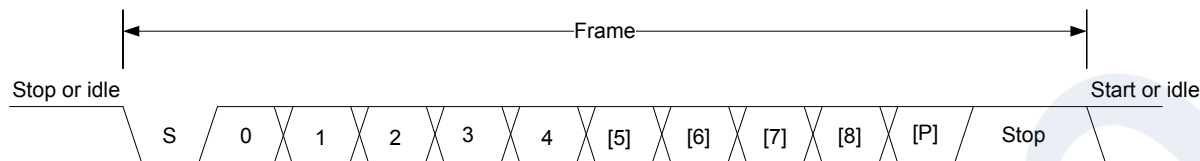

Figure 21.2. Frame Format

The number of data bits in a frame is set by DATABITS in EUSART_n_FRAMECFG, see [Table 21.3 Data Bits on page 639](#), and the number of stop-bits is set by STOPBITS in EUSART_n_FRAMECFG, see [Table 21.4 Stop Bits on page 639](#). Whether or not a parity bit should be included, and whether it should be even or odd is defined by PARITY, also in EUSART_n_FRAMECFG. For proper and reliable communication, all parties of a transfer must agree on the frame format prior to the start of the transfer.

Table 21.3. Data Bits

EUSART _n _FRAMECFG_DATABITS[3:0]	Number of Data bits
0001	7
0010	8 (Default)
0011	9

Table 21.4. Stop Bits

EUSART _n _FRAMECFG_STOPBITS[1:0]	Number of Stop bits
00	0.5 (HF clock operation only)
01	1 (Default)
10	1.5 (HF clock operation only)
11	2

The order in which the data bits are transmitted and received is defined by MSBF in EUSART_n_CFG0. When MSBF is cleared, data in a frame is sent and received with the least significant bit first. When it is set, the most significant bit comes first.

The frame format used by the transmitter can be inverted by setting TXINV in EUSART_n_CFG0, and the format expected by the receiver can be inverted by setting RXINV in EUSART_n_CFG0. These bits affect the entire frame, not only the data bits. An inverted frame has a low idle state, a high start-bit, inverted data and parity bits, and low stop-bits.

21.3.2.2 Parity Bit Calculation and Handling

When parity bit is enabled, hardware automatically calculates and inserts a parity bit into outgoing frames, and verifies the received parity bit in incoming frames. The possible parity modes are defined in [Table 21.5 Parity Bits on page 640](#). When even parity is chosen, a parity bit is inserted to make the number of high bits (data + parity) even. If odd parity is chosen, the parity bit makes the total number of high bits odd. When parity bit is disabled, which is the default configuration, the parity bit is omitted.

Table 21.5. Parity Bits

EUSART _n _FRAMECFG_PARITY[1:0]	Description
00	No parity bit (Default)
01	Reserved
10	Even parity
11	Odd parity

21.3.2.3 Clock Generation

The EUSART clock defines the transmission and reception data rate. The baud rate is given by [Figure 21.3 EUSART Baud Rate on page 641](#).

$$br = f_{EUSARTn} / (\text{oversample} \times (1 + EUSARTn_CLKDIV/256))$$

Figure 21.3. EUSART Baud Rate

where $f_{EUSARTn}$ is the peripheral clock frequency and oversample is the oversampling rate as defined by OVS in EUSARTn_CFG0, see [Table 21.6 Oversampling \(EUSARTn_CFG0_OVS\) on page 641](#). Note that different instances of the EUSART inside a device may use different peripheral clocks. The peripheral clock may be generically referred to in this chapter as `clk_per`.

Note: Please note that high frequency clocks should not be selected as UART clock source when nominal voltage is 0.9V.

Note:

Please note that when EUSARTn_CFG0_OVS is set to OVS_DISABLE (0x4), the peripheral clock frequency must be at least three times higher than the chosen baud rate. This condition is given in [Figure 21.4 Requirement for EUSARTn_CFG0_OVS = OVS_DISABLE on page 641](#).

$$f_{EUSARTn} / br \geq 3.0$$

Figure 21.4. Requirement for EUSARTn_CFG0_OVS = OVS_DISABLE

Table 21.6. Oversampling (EUSARTn_CFG0_OVS)

OVS[2:0]	Oversample
000	16 (HF clock operation only)
001	8 (HF clock operation only)
010	6 (HF clock operation only)
011	4 (HF clock operation only)
100	1 (OVS disabled - LF clock operation only)

Note: Please note that EUSARTn_CFG0_OVS must not be set to OVS_DISABLE (0x4) when one of the high frequency clocks is selected as EUSARTn peripheral clock source. When one of the low frequency clocks (LFXO/LFRCO) is selected as EUSARTn peripheral clock source, EUSARTn_CFG0_OVS must be set to OVS_DISABLE (0x4).

The EUSART has a fractional clock divider to allow the EUSART clock to be controlled more accurately than what is possible with a standard integral divider. The clock divider used in the EUSART is a 20-bit value, with a 15-bit integral part and an 5-bit fractional part. The fractional part is configured in the lower 5 bits of DIV in EUSARTn_CLKDIV. Fractional clock division is implemented by distributing the selected fraction over thirty two baud periods. The fractional part of the divider tells how many of these periods should be extended by one peripheral clock cycle.

Given a desired baud rate $br_{desired}$, the clock divider EUSARTn_CLKDIV can be calculated by using [Figure 21.5 EUSART Desired Baud Rate on page 641](#):

$$EUSARTn_CLKDIV = 256 \times (f_{EUSARTn} / (\text{oversample} \times br_{desired}) - 1)$$

Figure 21.5. EUSART Desired Baud Rate

[Table 21.7 EUSART Baud Rates @ 4 MHz Peripheral Clock with 20 Bit CLKDIV on page 642](#) shows a set of desired baud rates and how accurately the EUSART is able to generate these baud rates when running at a 4 MHz peripheral clock, using 16x or 8x oversampling.

Table 21.7. EUSART Baud Rates @ 4 MHz Peripheral Clock with 20 Bit CLKDIV

Desired baud rate [baud/s]	EUSARTn_CFG0_OVS =00			EUSARTn_CFG0_OVS =01		
	EUSARTn_CLKDIV/256 (to 32nd position)	Actual baud rate [baud/s]	Error %	EUSARTn_CLKDIV/256 (to 32nd position)	Actual baud rate [baud/s]	Error ¹ [%]
600	415,6563	600,015	0,003	832,3438	599,9925	-0,001
1200	207,3438	1199,94	-0,005	415,6563	1200,03	0,003
2400	103,1563	2400,24	0,010	207,3438	2399,88	-0,005
4800	51,09375	4799,04	-0,020	103,1563	4800,48	0,010
9600	25,03125	9603,842	0,040	51,09375	9598,08	-0,020
14400	16,375	14388,49	-0,080	33,71875	14401,44	0,010
19200	12,03125	19184,65	-0,080	25,03125	19207,68	0,040
28800	7,6875	28776,98	-0,080	16,375	28776,98	-0,080
38400	5,5	38461,54	0,160	12,03125	38369,3	-0,080
57600	3,34375	57553,96	-0,080	7,6875	57553,96	-0,080
76800	2,25	76923,08	0,160	5,5	76923,08	0,160
115200	1,15625	115942	0,644	3,34375	115107,9	-0,080
230400	0,09375	228571,4	-0,794	1,15625	231884,1	0,644

1 In addition to error introduced by oscillator frequency variation

Table 21.8 EUSART0 Baud Rates in LF mode @ 32.768 kHz Peripheral Clock with 20 bit CLKDIV on page 642 shows a set of desired baud rates and how accurately the EUSART0 is able to generate these baud rates when running from a 32.768 kHz peripheral clock in LF mode.

Table 21.8. EUSART0 Baud Rates in LF mode @ 32.768 kHz Peripheral Clock with 20 bit CLKDIV

Desired baud rate [baud/s]	EUSART0_CLKDIV/256	Actual baud rate [baud/s]	Error ¹ [%]
300	108,21875	300,0217	0.01
600	53,625	599,8719	-0.02
1200	26,3125	1199,744	-0.02
2400	12,65625	2399,487	-0.02
4800	5,8125	4809,982	0.21
9600	2,40625	9619,963	0.21

1 In addition to error introduced by oscillator frequency variation

21.3.2.4 Auto Baud Detection (HF clock only)

Setting AUTOBAUDEN in EUSARTn_CFG0 uses the first frame received to automatically set the baud rate provided that it contains 0x55 (IrDA uses 0x00) and is sent out as LSB first and there is no break in the frame. The receiver will measure the number of local clock cycles between the beginning of the START bit and the beginning of the 8th data bit. The DIV field in EUSARTn_CLKDIV will be overwritten with the new value. The OVS in EUSARTn_CFG0 and the +1 count of the Baud Rate equation are already factored into the result that gets written into the DIV field. To restart autobaud detection, clear AUTOBAUDEN and set it high again. Since the auto baud rate detection is done over 8 baud times, only the upper 3 bits of the fractional part of the clock divider are populated.

Auto baud detection has associated status bit EUSARTn_STATUS_AUTOBAUDDONE and interrupt flag EUSARTn_IF_AUTOBAUD-DONE. Both the status and the interrupt flag get set after auto baud detection is complete and DIV field in EUSARTn_CLKDIV is overwritten with the new value.

Note:

- If autobaud detection is enabled, software must wait for autobaud detection to complete before transmitting any data.
- Autobaud should be used only during times when it is known that the transmitter will be sending the required data word.
- Autobaud detection is not available when operating with LF clock source.
- For autobaud to work with IrDA, there should be odd parity or no parity in the received data frame.

21.3.2.5 Data Transmission

Asynchronous data transmission is initiated by writing data to the transmit FIFO using one of the methods described in [21.3.2.5.1 Transmit FIFO Operation](#). When the transmission shift register is empty and if the transmitter is enabled, a frame from the transmit FIFO is loaded into the shift register and transmission begins. Note that the frame loading in to the shift register can also be blocked if CTSEN is set in EUSARTn_CFG0 but the CTS input is inactive. When the frame has been transmitted, a new frame is loaded into the shift register if available, and transmission continues. If the transmit FIFO is empty, the transmitter goes to an idle state, waiting for a new frame to become available.

Transmission is enabled through the command register EUSARTn_CMD by setting TXEN, and disabled by setting TXDIS in the same command register. When the transmitter is disabled using TXDIS, any ongoing transmission is aborted, and any frame currently being transmitted is discarded. When disabled, the TX output goes to an idle state, which by default is a high value. Whether or not the transmitter is enabled at a given time can be read from TXENS in EUSARTn_STATUS.

When the EUSART transmitter is enabled and there is no data in the transmit shift register or transmit FIFO, the TXC status flag in EUSARTn_STATUS and the TXC interrupt flag in EUSARTn_IF are set, signaling that the transmission is complete. The TXC status flag is cleared when a new frame becomes available for transmission, but the TXC interrupt flag must be cleared by software.

Note: (1) Condition for TX to send data out: TX is enabled and there is data available in the TX FIFO and CTS is either not enabled, or if it is enabled, then it is active. (2) If TX output is tri-stated using TXDIS command or TXDISAT setting, then the TX module will still send out data (emptying the FIFO) if condition in point 1 is satisfied, even though the pad is tristated. Restriction: User should not set TXEN when the output is tristated.

21.3.2.5.1 Transmit FIFO Operation

The transmit FIFO is a 16 deep FIFO. A frame can be loaded into the FIFO by writing to EUSARTn_TXDATA. Using EUSARTn_TXDATA allows 9 bits to be written to the FIFO, as well as a set of control bits regarding the transmission of the written frame. Every frame in the FIFO is stored with 9 data bits and additional transmission control bits. A frame is loaded from the FIFO in to the shift register if the transmitter is enabled.

Figure 21.6 Transmit FIFO Operation on page 644 shows the basics of the transmit FIFO.

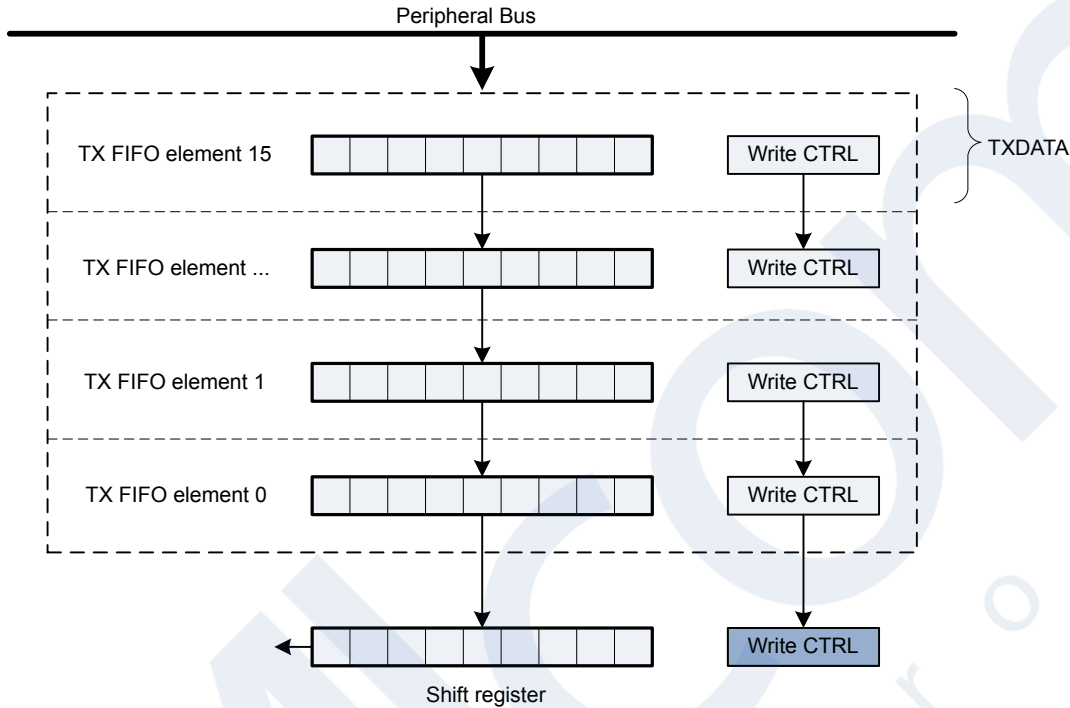

Figure 21.6. Transmit FIFO Operation

In addition to the interrupt flag TXC in EUSARTn_IF and status flag TXC in EUSARTn_STATUS which are set when the transmission is complete, TXFL in EUSARTn_STATUS and the TXFL interrupt flag in EUSARTn_IF are used to indicate the level of the transmit FIFO. TXFIW in EUSARTn_CFG1 controls the level at which these bits are set. The user can choose a transmit FIFO watermark level in TXFIW field of EUSARTn_CFG1 register in order to program when the TXFL interrupt should be triggered.

There is a TXIDLE status bit in EUSARTn_STATUS to provide an indication of when the transmitter is idle. The count of TX valid FIFO entries is called TXFCNT in EUSARTn_STATUS.

The transmit FIFO can be cleared by setting CLEARTX in EUSARTn_CMD. Since this is an Async FIFO, the user needs to first issue the CLEARTX command and then wait on the CLEARTXBUSY status flag until it goes low. EUSART must be enabled (EUSARTn_EN should be set) for the flush to work. EUSART should not be transmitting when CLEARTX command gets issued (can be achieved by disabling the transmitter). Any frame present in the transmit shift register currently being transmitted will not be aborted due to the flush. Transmission of this frame will be completed. Note that the transmit shift register is never used to store a transmit frame, i.e., if the transmitter is not enabled then the data stays in the transmit FIFO until the transmitter gets enabled. Whenever a frame is loaded in to the transmit shift register, the transmission starts immediately.

Transmit FIFO Status Flags

TX FIFO has two associated status flags: TXFL (set when there is space for data in the TX FIFO, depends on the setting in the TXFIW in CFG1 register) and TXFCNT (count of number of TX frames in the FIFO). These status flags remain set as long as the underlying condition is true, even if the EUSART is disabled (i.e., EUSARTn_EN is 0). It is possible to write to the TX FIFO while EUSART is disabled, this will impact the two flags mentioned above.

Transmit FIFO Interrupt Flags

TX FIFO has two associated interrupt flags: TXFL and TXOF. TXFL is set when space becomes available in the FIFO, depends on TXFIW in CFG1 register. Reset value for TXFIW is such that TXFL gets set as soon the chip comes out of reset (so the interrupt should

be cleared once TXFIW is updated). TXFL remains set as long as the underlying condition is true even if the EUSART is disabled. This means that if a software clear is done for TXFL, then the interrupt will get set again after the clear if the underlying condition is still true (this will happen even if the EUSART is disabled). Writing more data to the FIFO or disabling the TXFL will make the TXFL go away (even if the EUSART is disabled). When writing more frames to the transmit FIFO than there is free space for, the TXOF interrupt flag in EUSARTn_IF will be set, indicating the overflow. The data already in the transmit FIFO is preserved in this case, and no data is written. Note that TXOF can also trigger if DMA tries to write to the FIFO while a TX Flush operation is going on (Flush is activated by setting CMD.CLEAR_TX). No data will be written to the FIFO in this case. TXOF triggers only once every time an overflow occurs.

Note: (EUSART0 only) In LF clock mode, the TXFL interrupt flag and the TXFL wakeup flag differ slightly in their behavior. IF.TXFL is always set out of reset since there is space available in the FIFO. However, the TXFL wakeup flag is only set after a FIFO read happens and the space that becomes available in the FIFO is the same as programmed in TXFIW in EUSART0_CFG1.

21.3.2.5.2 Frame Transmission Control

The transmission control bits, which can be written using EUSARTn_TXDATA, affect the transmission of the written frame. The following options are available:

- **Generate break:** By setting TXBREAK, the output will be held low during the stop-bit period to generate a framing error. A receiver that supports break detection detects this state, allowing it to be used e.g. for framing of larger data packets. The line is driven high before the next frame is transmitted so the next start condition can be identified correctly by the recipient. Continuous breaks lasting longer than a EUSART frame are thus not supported. GPIO can be used for this.
- **Disable transmitter after transmission:** If TXDISAT is set, the transmitter is disabled after the frame has been fully transmitted.
- **Enable receiver after transmission:** If RXENAT is set, the receiver is enabled after the frame has been fully transmitted. It is enabled in time to detect a start-bit directly after the last stop-bit has been transmitted.
- **Unblock receiver after transmission:** If UBRXAT is set, the receiver is unblocked and RXBLOCK is cleared after the frame has been fully transmitted.
- **Tristate transmitter after transmission:** If TXTRIAT is set, TXTRI is set after the frame has been fully transmitted, tristating the transmitter output. Note that if there are more frames in the TX FIFO after the tristating has happened and the transmitter is enabled, then the transmitter will try to send them out but since the output is tristated, nothing will show up at the transmitter output. The FIFO however will get emptied because of the transmitter attempting to send these frames out. If the target is to automatically tristate the TX line whenever the transmitter is idle, then that can be done by setting AUTOTRI in EUSARTn_CFG0. If AUTOTRI is set TXTRI status flag is always read as 0.

21.3.2.5.3 TX Status Flags

The following status flags should be used with care keeping in mind the external sources that can impact these flags as well as the synchronization delay when the status signal crosses over from the EUSART Core clock domain to the APB clock domain. FIFO related status flags were already discussed in [21.3.2.5.1 Transmit FIFO Operation](#), the remaining flags are mentioned below:

- **TXENS:** Enable sources: (1) TXEN command from software, (2) PRS trigger (when TXTEN=1). Disable Sources: (1) TXDIS command from software, (2) PERR/FERR (when ERRSTX=1), (3) Software when TXDISAT is set to 1 for a frame.
- **TXTRI:** Enable sources: (1) TXTRIEN command from software, (2) Software when TXTRIAT is set to 1 for a frame. Disable sources: (1) TXTRIDIS command from software.
- **TXIDLE:** Set whenever the TX module is idle.
- **TXC:** Set whenever the TX module goes to idle and both the TX FIFO and the TX shift register are empty. Cleared when either TX FIFO or the TX shift register has data.

21.3.2.5.4 Transmission Delay

By configuring TXDELAY in EUSARTn_CFG1, the transmitter can be forced to wait a number of bit-periods from when it is ready to transmit data, to when it actually transmits the data. This delay is only applied to the first frame transmitted after the transmitter has been idle. When transmitting frames back-to-back the delay is not introduced between the transmitted frames.

This is useful on half duplex buses, because the receiver always returns received frames to software during the first stop-bit. The bus may still be driven for up to 3 bit periods, depending on the current frame format. Using the transmission delay, a transmission can be started when a frame is received, and it is possible to make sure that the transmitter does not begin driving the output before the frame on the bus is completely transmitted.

21.3.2.6 Data Reception

Data reception is enabled by setting RXEN in EUSARTn_CMD. When the receiver is enabled, it actively samples the input looking for a transition from high to low indicating the start baud of a new frame. When a start baud is found, reception of the new frame begins. When the frame has been received, it is pushed into the receive FIFO, making the shift register ready for another frame of data, and the receiver starts looking for another start baud. If a frame is received while the receive FIFO is full, the received frame is discarded and the RXOF interrupt flag in EUSARTn_IF is set to indicate the FIFO overflow.

The receiver can be disabled by setting the command bit RXDIS in EUSARTn_CMD. Any frame currently being received, when the receiver is disabled, is discarded. Whether or not the receiver is enabled at a given time can be read out from RXENS in EUSARTn_STATUS.

21.3.2.6.1 Receive FIFO Operation

The receive-FIFO is a 16 deep FIFO. Data can be read from the receive FIFO via EUSARTn_RXDATA. EUSARTn_RXDATA gives access to the received frame. This register also contains parity error and framing error information of the received frame. When a frame is read from the receive FIFO using EUSARTn_RXDATA, the frame is pulled out of the FIFO, making room for a new frame. If an attempt is done to read more frames from the FIFO than what is available, the RXUF interrupt flag in EUSARTn_IF is set to signal the underflow, and the data read from the FIFO is undefined.

Frames can be read from the receive FIFO without removing the data by using EUSARTn_RXDATAP. EUSARTn_RXDATAP gives access to the first frame in the FIFO with status bits. The data read from this register when the receive FIFO is empty is undefined. No underflow interrupt is generated by a read using this register, i.e. RXUF in EUSARTn_IF is never set as a result of reading from EUSARTn_RXDATAP.

The basic operation of the receive FIFO is shown in [Figure 21.7 EUSART Receive FIFO Operation on page 647](#).

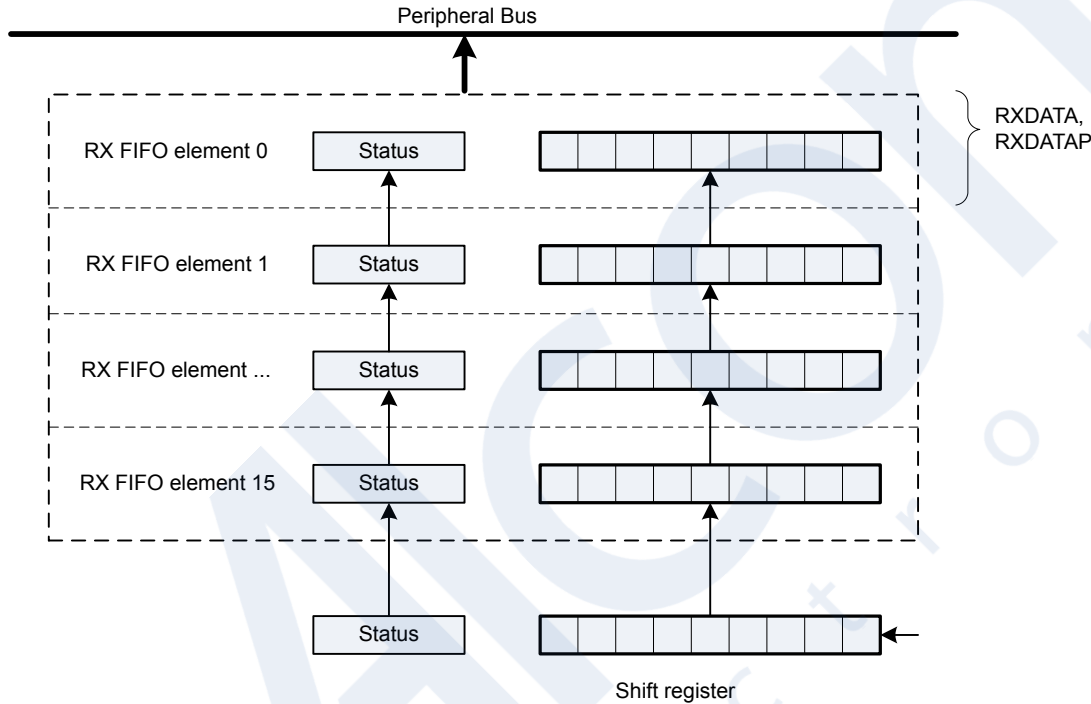

Figure 21.7. EUSART Receive FIFO Operation

Receive FIFO Status Flags

Receive FIFO has two associated status flags: RXFL (set when number of available frames in the receive FIFO is at least number of frames set by RXFIW in CFG1 register) and RXFULL (set when receive FIFO is full). These status flags remain set as long as the underlying condition is true, even if the EUSART is disabled (i.e., EUSARTn_EN is 0). It is possible to read from the receive FIFO while EUSART is disabled, this will impact the two status flags mentioned above. The status flags RXFL and RXFULL are automatically cleared by hardware when their condition is no longer true.

Receive FIFO Interrupt Flags

Receive FIFO has four associated interrupt flags: RXFL, RXFULL, RXOF and RXUF. RXFL is set when number of available frames in the receive FIFO is at least number of frames set by RXFIW in CFG1 register. RXFULL is set when receive FIFO is full. Both RXFL and RXFULL remains set as long as the underlying condition is true even if EUSART is disabled. This means that if a software clear is done for RXFL / RXFULL while the underlying condition of respective interrupt is still true, the corresponding interrupt will get set again after the clear (this will happen even if EUSART is disabled). Reading data from the FIFO or disabling the RXFL / RXFULL will block the respective interrupt to get set after a software clear (even if EUSART is disabled). RXOF is set when a new frame is received while the receive FIFO is full, indicating overflow. The new frame is discarded. RXOF triggers only once every time an overflow occurs. RXUF is set when an attempt (via RXDATA or DMA) is done to read more frames from the receive FIFO than what is available, indicating underflow. The data read from the FIFO is undefined. RXUF triggers every time an underflow occurs even if EUSART is disabled.

21.3.2.6.2 Blocking Incoming Data

When using hardware frame recognition, as detailed in [21.3.2.6.9 Multi-Processor Mode](#) and [21.3.2.8 Collision Detection](#), it is necessary to be able to let the receiver sample incoming frames without loading them into the receive FIFO. This is accomplished by blocking incoming data.

Incoming data is blocked as long as RXBLOCK in EUSARTn_STATUS is set. When blocked, frames received by the receiver will not be loaded into the receive FIFO, and software is not notified by the RXFL flag in EUSARTn_STATUS or the RXFL interrupt flag in EUSARTn_IF at their arrival. For data to be loaded into the receive FIFO, RXBLOCK must be cleared in the instant a frame is fully received by the receiver. RXBLOCK is set by setting RXBLOCKEN in EUSARTn_CMD and disabled by setting RXBLOCKDIS also in EUSARTn_CMD. There is one exception where data is loaded into the receive FIFO even when RXBLOCK is set. This is when an address frame is received while operating in multi-processor mode. See [21.3.2.6.9 Multi-Processor Mode](#) for more information.

Frames received containing framing or parity errors will not result in the FERR and PERR interrupt flags in EUSARTn_IF being set while RXBLOCK in EUSARTn_STATUS is set. Hardware recognition is not applied to these erroneous frames, and they are silently discarded.

The overflow interrupt flag RXOF in EUSARTn_IF will also not be set while RXBLOCK in EUSARTn_STATUS is set.

21.3.2.6.3 Data Sampling and Filtering

The receiver can sample incoming signal at a rate 16, 8, 6 or 4 times higher than the given baud rate, depending on the oversampling mode given by OVS in EUSARTn_CFG0. Lower oversampling rates make higher baud rates possible, but give less room for errors.

When a high-to-low transition is registered on the input while the receiver is idle, this is recognized as a start-bit, and the baud rate generator is synchronized with the incoming frame.

For oversampling modes 16, 8 and 6, every bit in the incoming frame is sampled three times to gain a level of noise immunity. These samples are aimed at the middle of the bit-periods, as visualized in [Figure 21.8 EUSART Sampling of Start and Data Bits](#) on page 649. With OVS=0 in EUSARTn_CFG0, the start and data bits are thus sampled at locations 8, 9 and 10 in the figure, locations 4, 5 and 6 for OVS=1 and locations 3, 4, and 5 for OVS=2.

Majority vote is used for all oversampling modes except 4X oversampling and when oversampling is disabled. In 4X oversampling mode, a single sample is taken at position 3 as shown in [Figure 21.8 EUSART Sampling of Start and Data Bits](#) on page 649.

When oversampling is disabled i.e. OVS = DISABLE, there is only one available location for sampling the start and data bits and so majority vote is not used.

Note: When operating in HF clock mode, oversampling must be set to 4, 6, 8, or 16x. When operating in LF clock mode, oversampling must be disabled.

Software can disable majority vote by setting MVDIS in EUSARTn_CFG0. When majority vote is disabled by software, a single sample is taken at location 9 in the figure for OVS=0, location 5 for OVS=1 and location 4 for OVS=2.

If the value of the start bit is found to be high, the reception of the frame is aborted, filtering out false start bits possibly generated by noise on the input.

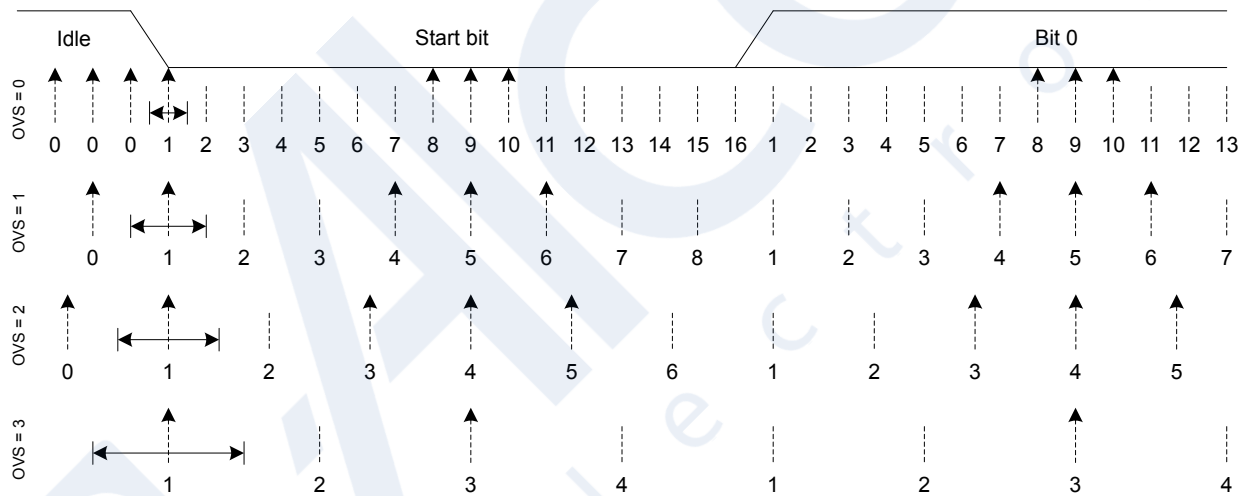

Figure 21.8. EUSART Sampling of Start and Data Bits

If the baud rate of the transmitter and receiver differ, the location each bit is sampled will be shifted towards the previous or next bit in the frame. This is acceptable for small errors in the baud rate, but for larger errors, it will result in transmission errors.

When the number of stop bits is 1 or more, stop bits are sampled like the start and data bits as seen in [Figure 21.9 EUSART Sampling of Stop Bits when Number of Stop Bits are 1 or More](#) on page 650. When a stop bit has been detected, EUSARTn is ready for a new start bit.

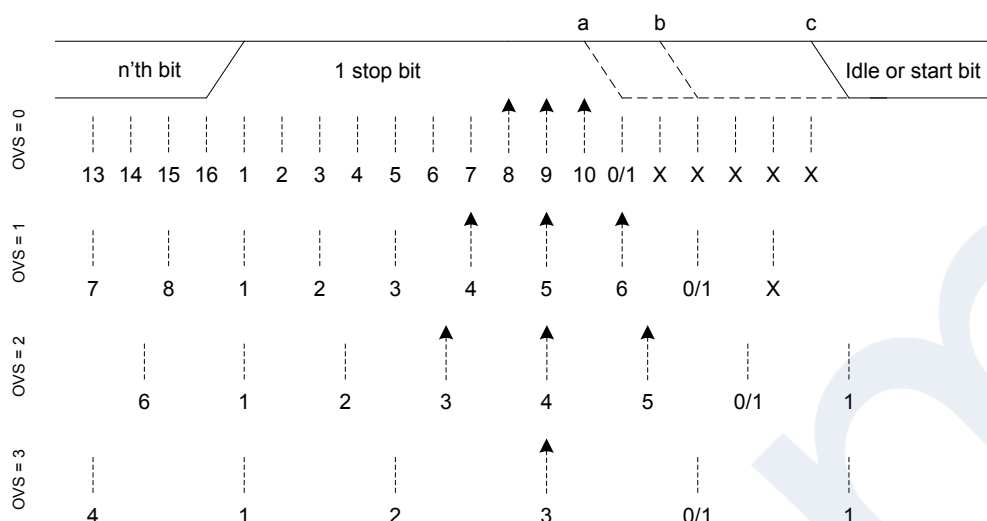

Figure 21.9. EUSART Sampling of Stop Bits when Number of Stop Bits are 1 or More

When working with stop bit lengths of half a baud period, the above sampling scheme no longer suffices. In this case, the stop-bit is not sampled, and no framing error is generated in the receiver if the stop-bit is not generated. However, the line must still be driven high before the next start bit for the EUSART to successfully identify the start bit.

21.3.2.6.4 RX Status Flags

The following status flags should be used with care keeping in mind the external sources that can impact these flags as well as the synchronization delay when the status signal crosses over from the EUSART Core clock domain to the APB clock domain. FIFO related status flags were already discussed in [21.3.2.6.1 Receive FIFO Operation](#), the remaining flags are mentioned below:

- **RXENS**: set when RX is enabled. Enable sources: (1) RXEN command from software, (2) PRS trigger (when RXTEN=1), (3) TX (when RXENAT=1). Disable Sources: (1) RXDIS command from software, (2) Parity / framing error (when ERRSRX=1).
- **RXBLOCK**: set when RX is blocked which means RX keeps receiving frames but does not push received frame to receive FIFO. Enable sources: (1) RXBLOCKEN command from software. Disable Sources: (1) RXBLOCKDIS command from software, (2) STARTFRAME match (when SFUBRX=1), (3) TX (when UBRXAT=1).
- **RXIDLE**: Set when RX module completes pushing the last received frame to receive FIFO (if receive FIFO has space) and is not receiving any new frame or when RX gets disabled.
- **AUTOBAUDDONE**: Set when auto baud detection is complete and DIV field in EUSARTn_CLKDIV is overwritten with the detected value.

21.3.2.6.5 Parity Error

When parity bits are enabled, a parity check is automatically performed on incoming frames. When a parity error is detected in an incoming frame, the data parity error bit PERR in the frame is set, as well as the interrupt flag PERR in EUSARTn_IF. Frames with parity errors are loaded into the receive FIFO like regular frames.

PERR can be accessed by reading the frame from the receive FIFO using the EUSARTn_RXDATA, or EUSARTn_RXDATAP registers.

If ERRSTX in EUSARTn_CFG0 is set, the transmitter is disabled on received parity errors. If ERRSRX in EUSARTn_CFG0 is set, the receiver is disabled on parity errors.

21.3.2.6.6 Framing Error and Break Detection

A framing error is the result of an asynchronous frame where the stop bit was sampled to a value of 0. This can be the result of noise and baud rate errors, but can also be the result of a break generated by the transmitter on purpose.

When a framing error is detected in an incoming frame, the framing error bit FERR in the frame is set. The interrupt flag FERR in EUSARTn_IF is also set. Frames with framing errors are loaded into the receive FIFO like regular frames.

If ERRSTX in EUSARTn_CFG0 is set, the transmitter is disabled on received framing errors. If ERRSRX in EUSARTn_CFG0 is set, the receiver is disabled on framing errors.

21.3.2.6.7 Programmable Start Frame

The EUSART can be configured to start receiving data when a special start frame is detected on the input. This can be useful when operating in low energy modes, allowing other devices to gain the attention of the EUSART by transmitting a given frame.

When SFUBRX in EUSARTn_CFG1 is set, an incoming frame matching the frame defined in EUSARTn_STARTFRAME will result in RXBLOCK in EUSARTn_STATUS being cleared. This can be used to enable reception when a specified start frame is detected. If the receiver is enabled and blocked, i.e. RXENS and RXBLOCK in EUSARTn_STATUS are set, the receiver will receive all incoming frames, but unless an incoming frame is a start frame it will be discarded and not loaded into the receive FIFO. When a start frame is detected, the block is cleared, and frames received from that point, including the start frame, are loaded into the receive FIFO.

An incoming start frame results in the STARTFIF interrupt flag in EUSARTn_IF being set, regardless of the value of SFUBRX in EUSARTn_CFG1. This allows an interrupt to be made when the start frame is detected. The interrupt will be set even if the receiver is blocked i.e. EUSARTn_STATUS_RXBLOCK = 1.

Note: The receiver must be enabled for start frames to be detected. Please note that, if another UART device sends a start frame but a parity and/or framing error occurs during the reception, the received frame is not detected as a start frame.

21.3.2.6.8 Programmable Signal Frame

As well as the configurable start frame, a special signal frame can be specified. When a frame matching the frame defined in EUSARTn_SIGFRAME is detected by the receiver, the SIGF interrupt flag in EUSARTn_IF is set. As like start frame detection, the interrupt will be set even if the receiver is blocked i.e. EUSARTn_STATUS_RXBLOCK = 1.

One use of the programmable signal frame is to signal the end of a multi-frame message transmitted to the EUSART. An interrupt will then be triggered when the packet has been completely received, allowing software to process it. Used in conjunction with the programmable start frame and DMA, this makes it possible for the EUSART to automatically begin the reception of a packet on a specified start frame, load the entire packet into memory, and give an interrupt when reception of a packet has completed. When one of the low frequency oscillators (LFXO, LFRCO) is used as EUSART0 peripheral clock source, the device can thus wait for data packets in EM2, and only be woken up when a packet has been completely received.

Note: The receiver must be enabled for a signal frame to be detected. If a parity and/or framing error occurs during the reception of a signal frame, the received frame is not detected as a signal frame.

21.3.2.6.9 Multi-Processor Mode

To simplify communication between multiple processors, the EUSART supports a special multi-processor mode. In this mode the 9th data bit in each frame is used to indicate whether the content of the remaining 8 bits is data or an address.

When multi-processor mode is enabled, an incoming 9-bit frame with the 9th bit equal to the value of MPAB in EUSARTn_CFG0 is identified as an address frame. When an address frame is detected, the MPAF interrupt flag in EUSARTn_IF is set, and the address frame is loaded into the receive register. This happens regardless of the value of RXBLOCK in EUSARTn_STATUS.

Multi-processor mode is enabled by setting MPM in EUSARTn_CFG0, and the value of the 9th bit in address frames can be configured in EUSARTn_CFG0_MPAB. Note that the receiver must be enabled for address frames to be detected. The receiver can be blocked however, preventing data from being loaded into the receive FIFO while looking for address frames.

The following section explains basic usage of the multi-processor mode:

EUSART Multi-processor Mode Example

1. All devices on the bus enable multi-processor mode and enable and block the receiver. They will now not receive data unless it is an address frame. MPAB in EUSARTn_CFG0 is set to desired value to identify frames with the 9th bit value equal to MPAB as address frames.
2. A transmitting device sends a frame containing the address of a different device and with the 9th bit set to value of MPAB.
3. All devices receive the address frame and get an interrupt. They can read the address from the receive FIFO. The selected device unblocks the receiver to start receiving data from the transmitter.
4. The transmitter sends data with the 9th bit set to opposite value of MPAB.
5. Only the addressed device with RX enabled and unblocked receives the data. When transmission is complete, the device blocks the receiver and waits for a new address frame.

When a device has received an address frame and wants to receive the following data, it must make sure the receiver is unblocked before the next frame has been completely received in order to prevent data loss. One option is to set SFUBRX in EUSARTn_CFG1 and set the address frame as start frame in EUSARTn_STARTFRAME. This will handle automatic unblocking of RX when address frame is received.

21.3.2.6.10 RX Timeout

A RX timeout function can be enabled by setting EUSART_CFG1_RXTIMEOUT to desired value. When enabled, a timer gets started after every successful frame reception. If timeout occurs before the next RX start bit is received, EUSART_IF_RXTO gets set which can be used to wake-up the system to handle received data. This is shown in [Figure 21.10 RX Timeout on page 652](#). If the next RX start bit is received before timeout occurs, no interrupt gets generated, the timer is reset and will only be started again after the on-going frame reception is complete.

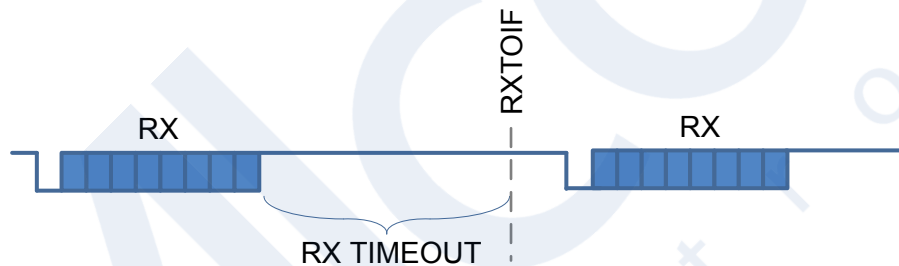

Figure 21.10. RX Timeout

Please note that the timer does not get started in following scenarios:

- If auto baud rate detection is enabled and auto baud rate has not been found, the timer does not get started after the first frame which is used to detect the baud rate automatically.
- If a frame is received while RX is blocked, the timer does not get started.
- If EUSART_CFG0_SKIPPERF is set to '1' and a frame is received with a parity error, the timer does not get started.

Please also note that the UART RX input line must be in idle state after frame reception for the timer to start.

Note: When EUSARTn_FRAMECFG_STOPBITS is set to a fractional value i.e. 'HALF' or 'ONEANDHALF', the fractional value is rounded to nearest value and so RX timeout is extended by 0.5 baud width per frame.

21.3.2.7 Local Loopback

The EUSARTn receiver samples RX by default, and the transmitter drives TX by default. This is not the only option however. When LOOPBK in EUSARTn_CFG0 is set, the RX pin is connected to the TX pin as shown in [Figure 21.11 EUSART Local Loopback on page 653](#). This is useful for debugging, as the EUSARTn can receive the data it transmits, but it is also used to allow the EUSARTn to read and write to the same pin, which is required for some half duplex communication modes. In this mode, the TX pin must be enabled as an output in the GPIO.

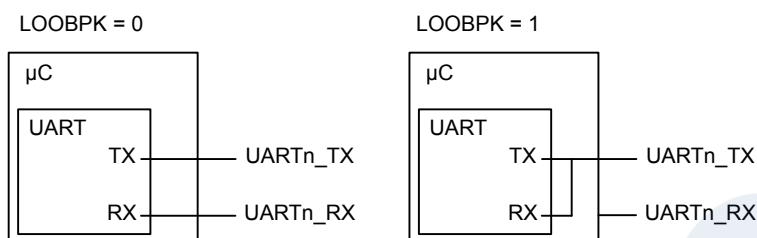

Figure 21.11. EUSART Local Loopback

21.3.2.8 Collision Detection

EUSARTn supports a basic form of collision detection. When the receiver is connected to the output of the transmitter, either by using the LOOPBK bit in EUSARTn_CFG0 or through an external connection, this feature can be used to detect whether data transmitted on the bus by the EUSARTn did get corrupted by a simultaneous transmission by another device on the bus.

For collision detection to be enabled, CCEN in EUSARTn_CFG0 must be set, and the receiver enabled. The data sampled by the receiver is then continuously compared with the data output by the transmitter. If they differ, the CCF interrupt flag in EUSARTn_IF is set. The collision check includes all bits of the transmitted frames. The CCF interrupt flag is set once for each bit sampled by the receiver that differs from the bit output by the transmitter. When the transmitter output is disabled, i.e. the transmitter is tristated, collisions are not registered.

Note: Please note that collision detection supports only baudrates up to 1Mbps.

21.3.2.9 Half Duplex Communication

When doing full duplex communication, two data links are provided, making it possible for data to be sent and received at the same time. In half duplex mode, data is only sent in one direction at a time. There are several possible half duplex setups, as described in the following sections.

21.3.2.9.1 Single Data-link

In this setup, the EUSART both receives and transmits data on the same pin. This is enabled by setting LOOPBK in EUSARTn_CFG0, which connects the receiver to the transmitter output. Because they are both connected to the same line, it is important that the EUSART transmitter does not drive the line when receiving data, as this would corrupt the data on the line.

When communicating over a single data-link, the transmitter must thus be tristated whenever not transmitting data. This is done by setting the command bit TXTRIE in EUSARTn_CMD, which tristates the transmitter. Before transmitting data, the command bit TXTRIDIS, also in EUSARTn_CMD, must be set to enable transmitter output again. Whether or not the output is tristated at a given time can be read from TXTRI in EUSARTn_STATUS. If TXTRI is set when transmitting data, the data is shifted out of the shift register, but is not put out on TX line.

When operating a half duplex data bus, it is common to have a main bus controller, which first transmits a request to one of the secondary devices on the bus, then receives a reply. In this case, the frame transmission control bits, which can be set by writing to EUSARTn_TXDATA, can be used to make the EUSART automatically disable transmission, tristate the transmitter and enable reception when the request has been transmitted, making it ready to receive a response from the secondary device.

Tristating the transmitter can also be performed automatically by the EUSART by using AUTOTRI in EUSARTn_CFG0. When AUTOTRI is set, the EUSART automatically tristates TX line whenever the transmitter is idle, and enables transmitter output when the transmitter goes active. If AUTOTRI is set TXTRI is always read as 0.

Note: Another way to tristate the transmitter is to enable wired-and or wired-or mode in GPIO. For wired-and mode, outputting a 1 will be the same as tristating the output, and for wired-or mode, outputting a 0 will be the same as tristating the output. This can only be done on buses with a pull-up or pull-down resistor respectively.

21.3.2.9.2 Single Data-link with External Driver

Some communication schemes, such as RS-485 rely on an external driver. Here, the driver has an extra input which enables it, and instead of tristating the transmitter when receiving data, the external driver must be disabled.

This can be done manually by assigning a GPIO to turn the driver on or off.

Figure 21.12 EUSART Half Duplex Communication with External Driver on page 654 shows an example configuration using an external driver.

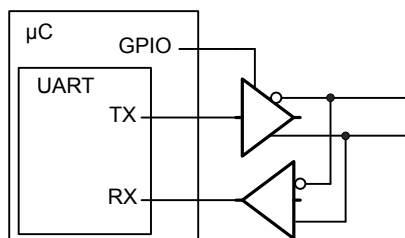

Figure 21.12. EUSART Half Duplex Communication with External Driver

21.3.2.9.3 Two Data-links

Some limited devices only support half duplex communication even though two data links are available. In this case software is responsible for making sure data is not transmitted when incoming data is expected.

21.3.2.10 Hardware Flow Control

Hardware flow control can be used to hold off the link partner's transmission until receive FIFO space is available. Use `RTSPEN` in `GPIO_DBUSEUSARTn_ROUTEEN` to enable RTS pin (CTS is an input so its pin is enabled by default). Port and Pin selection for RTS and CTS can be done in `GPIO_DBUSEUSARTn_RTROUTE/CTSROUTE`. RTS is an out going signal which indicates that receive FIFO space is available to receive a frame. The link partner is being requested to send its data when RTS is active. RTS activation can be made dependent on how much space is available in the receive FIFO using `RTSRXFW` in `EUSARTn_CFG1`. For debug use set `DBGHALT` in `EUSARTn_CFG1` which will force the RTS to request one frame from the link partner when the CPU core single steps. RTS is deactivated when RX is disabled.

CTS is an incoming signal to stop the next TX data from going out. CTS indicates that the link partner has receive FIFO space available, and the local transmitter is clear to send. When CTS deactivates in the middle of a frame, the frame currently being transmitted is completed before stopping. CTS operation needs to be enabled using `CFG1.CTSEN`.

The RTS and CTS are active low by default, but their polarity can be changed with `RTSINV` and `CTSINV` in `EUSARTn_CFG1` respectively.

21.3.2.11 Debug Halt

During single stepping, debug halt feature allows halting EUSART frame reception by deactivating RTS when the core is halted and continuing frame reception by activating RTS when the core is unhalted. EUSART debug halt can be enabled by setting `DBGHALT` in `EUSART_CFG1` to '1'. EUSART receiver must be enabled for debug halting.

When `EUSART_CFG1_DBGHALT` is not set or `EUSART_CFG1_DBGHALT` is set but chip halt is low, RTS is only dependent on the receive FIFO having space available to receive at least number of frames given by `EUSART_CFG1_RTSRXFW` settings.

When `EUSART_CFG1_DBGHALT` is set, RTS will remain deactivated as long as chip halt is high. When a low pulse is detected on chip halt while `DBGHALT` is set, RTS will be activated if receive FIFO has space available to receive at least number of frames given by `EUSART_CFG1_RTSRXFW` settings and no frame is being received. RTS will be deactivated again if chip halt goes back to high and receiver starts receiving a new frame or if receive FIFO does not have space available to receive at least number of frames given by `EUSART_CFG1_RTSRXFW` settings. This behavior allows single stepping to pulse the chip halt low for a cycle, and receive the next frame.

Please note that, if chip halt remains low for a short duration after RX is enabled while `DBGHALT` is set, initial low value of chip halt will be treated the same as a low pulse on chip halt.

As incoming frame is always received until receive FIFO is full regardless of the state of `DBGHALT` or chip halt, the link partner must stop transmitting when RTS is deactivated, or the receive FIFO could overflow.

All data in the transmit FIFO is sent out even when chip halt is asserted; therefore, DMA will need to be set to stop sending EUSART TX data during chip halt.

21.3.2.12 PRS-triggered Transmissions

If a transmission must be started on an event with very little delay, the PRS system can be used to trigger the transmission. The PRS channel to use as a trigger can be selected using `EUSARTn_TRIGGER.PRSSEL` in PRS. When a positive edge is detected on PRS signal, the receiver is enabled if `RXTEN` in `EUSARTn_TRIGCTRL` is set, and the transmitter is enabled if `TXTEN` in `EUSARTn_TRIGCTRL` is set. Only one signal input is supported by the EUSART.

21.3.2.13 PRS RX Input

The EUSART can be configured to receive data directly from a PRS channel by setting `RXPRSEN` in `EUSARTn_CFG1`. The PRS channel used is selected using `EUSARTn_RX.PRSSEL` in PRS.

21.3.2.14 DMA Support

The EUSART has full DMA support. The DMA controller can write to the transmit FIFO using the register `EUSARTn_TXDATA`, and it can read from the receive FIFO using the register `EUSARTn_RXDATA`. This enables 9 bit data + control/status bits transfers both to and from the EUSART.

A request for the DMA controller to read from the EUSART receive buffer can come from the following source:

- Receive FIFO is loaded with at least number of frames set by `RXFIW`.

A write request can come from the following source:

- Transmit FIFO has space for at least number of frames set by `TXFIW`

In some cases, it may be sensible to temporarily stop DMA read access to the EUSART when an error such as parity or framing error has occurred. This is enabled by setting `ERRSDMA` in `EUSARTn_CFG0`.

EUSART0 (EM2 Capable instance only) can also work with the DMA in low power mode so that the system does not have to wake up to EM0 to consume data. This can happen if `TXDMAWU` or `RXDMAWU` in the `EUSARTn_CFG1` is set. The DMA will be triggered when `TXFIW/RXFIW` samples are in the corresponding FIFO. The chip will enter EM1, DMA will then pop/ push all the elements of the corresponding FIFO and then the system will be put back to EM2.

21.3.2.15 Interrupts

The interrupts generated by the EUSART are combined into two interrupt vectors. Interrupts related to reception are assigned to one interrupt vector, and interrupts related to transmission are assigned to the other. Separating the interrupts in this way allows different priorities to be set for transmission and reception interrupts.

The transmission interrupt vector groups the transmission-related interrupts generated by the following interrupt flags:

- TXC
- TXFL
- TXOF
- CCF
- TXIDLE

The reception interrupt on the other hand groups the reception-related interrupts, triggered by the following interrupt flags:

- RXFL
- RXFULL
- RXOF
- RXUF
- PERR
- FERR
- MPAF
- START
- SIGF
- AUTOBAUDDONE
- RXTO

If EUSARTn interrupts are enabled, an interrupt will be made if one or more of the interrupt flags in `EUSARTn_IF` and their corresponding bits in `EUSARTn_IEN` are set. All interrupts can serve as wake up interrupts if enabled (EM2 Capable instance only).

21.3.2.16 EM2 operation (EUSART0 Only)

EUSART0 can operate in EM2 when running from an LF oscillator source (LF mode). Note that sending and receiving data in EM2 requires that the EUSART be connected to GPIO that are capable of operating in EM2. This includes all pins on Port A and Port B. Pins on Port C and Port D are not available for digital peripheral signalling in EM2 or EM3.

EM2 operation allows the EUSART to wait for an incoming UART frame, or even wait on the programmable start or signal frames while the system is consuming very little energy. When a UART frame is completely received, or a start/signal frame is detected, the CPU can quickly be woken up. Alternatively, multiple frames can be transferred via the Direct Memory Access (DMA) module into RAM memory before waking up the CPU. Similarly, data can be transmitted in EM2 with data from the CPU or through use of the DMA.

All interrupts can be used as wake up interrupts if enabled. None of the interrupts are sticky, i.e., the interrupt triggers only once whenever the interrupt condition is reached.

Note: When RXDMAWU or TXDMAWU is set in EUSART0_CFG1, the system will not be able to go to EM2 before all related EUSART0 DMA requests have been processed. This means that if RXDMAWU is set and the EUSART receives a frame, the system will wait to go to EM2 before the frame has been read from the EUSART. In order for the system to go back to EM2 during or after the final transmission (i.e. when DMA will no add more data to the TX FIFO), the wake request to DMA must be removed. There are two methods for doing this:

1. If RX does not need to remain active, software can disable the peripheral and clear the TXDMAWU bit in the ISR to prevent further DMA requests. The peripheral may be re-enabled after TXDMAWU is cleared. Note that while the peripheral is disabled, the EUSART cannot receive any new data, so this option should only be used if no data is expected.
2. If RX must remain active, it is recommended to disable TX, and then write dummy information into the FIFO until the TXFL flag will no longer trigger a new wakeup. This will prevent new DMA requests.

21.3.2.17 PRS

All PRS inputs are synchronized to the peripheral clock (clk_per) for the EUSART instance.

- RX PRS: Input goes to RX module for data reception if RXPRSEN set to 1
- TRIGGER PRS: Can be used to Enable TX and/or RX if TXTEN/RXTEN are set to 1

All PRS outputs come from clk_per flops.

- PRS_TX: Same as TX output (tx_out) of EUSART
- PRS_TXC: Same as the TXC status flag
- PRS_IRDA_TX: Registered (clk_per) version of IRHF output
- PRS_RXFL: Set if (rxdata_fifo_cnt > RXFIW)
- PRS_RTS: Same as RTS output (rts_out) of EUSART

21.3.2.18 IrDA operation

The EUSART supports IrDA operation using both HF and LF clocks. For IrDA with HF clock, the controls are given in IRHF_CFG register. For IrDA with LF clock (32.768 kHz), only RX is supported and the controls are given in IRLF_CFG register. Note that OVS must be disabled for LF operation.

Note: Note that break generation/ detection feature is not supported while IrDA is enabled, i.e., either IRHFEN or IRLFEN is set.

21.3.2.18.1 IRHF

The IRHF modulator implements the physical layer of the IrDA specification, which is necessary for communication over IrDA. The modulator takes the signal output from the EUSART module, and modulates it before it leaves the EUSART. In the same way, the input signal is demodulated before it enters the actual EUSART module. The modulator implements the original Rev. 1.0 physical layer and one high speed extension which supports speeds from 2.4 kbps to 1.152 Mbps.

The data from and to the EUSART is represented in a NRZ (Non Return to Zero) format, where the signal value is at the same level through the entire bit period. For IrDA, the required format is RZI (Return to Zero Inverted), a format where a “1” is signalled by holding the line low, and a “0” is signalled by a short high pulse. An example is given in [Figure 21.13 EUSART Example RZI Signal for a given EUSART Frame on page 657](#).

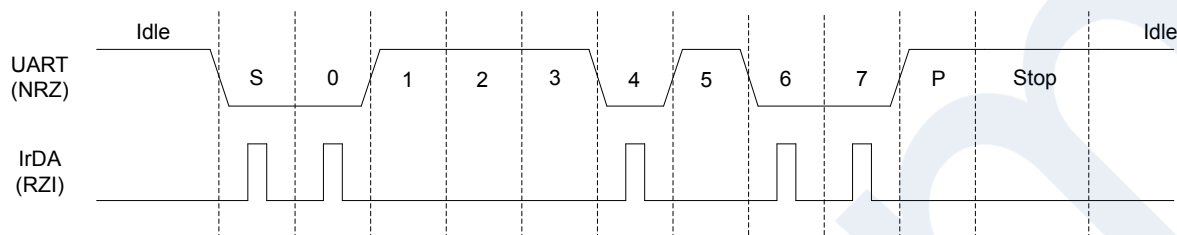

Figure 21.13. EUSART Example RZI Signal for a given EUSART Frame

The IrDA HF module is enabled by setting IRHFEN in IRHFCFG. The EUSART transmitter output and receiver input is then routed through the IrDA HF modulator.

The width of the pulses generated by the IrDA HF modulator is set by configuring IRHFPW in IRHFCFG register. Four pulse widths are available, each defined relative to the configured bit period as listed in [Table 21.9 EUSART IrDA Pulse Widths on page 657](#).

Table 21.9. EUSART IrDA Pulse Widths

IRHFPW	Pulse width OVS=0	Pulse width OVS=1	Pulse width OVS=2	Pulse width OVS=3
00	1/16	1/8	1/6	1/4
01	2/16	2/8	2/6	N/A
10	3/16	3/8	N/A	N/A
11	4/16	N/A	N/A	N/A

By default, no filter is enabled in the IrDA HF demodulator. A filter can be enabled by setting IRHFFILT in IRHFCFG. When the filter is enabled, an incoming pulse has to last for 5 consecutive clock cycles to be detected by the IrDA demodulator. When the filter is enabled, the minimum clock frequency required is based on the baud rate and OVS chosen. The frequency requirements are listed in [table Table 21.10 EUSART IrDA IRHFFILT=1, Min Clock Frequency Requirement \(MHz\) on page 657](#).

Table 21.10. EUSART IrDA IRHFFILT=1, Min Clock Frequency Requirement (MHz)

OVS	2.4 kb/s	9.6 kb/s	19.2 kb/s	38.4 kb/s	57.6 kb/s	115.2 kb/s	0.576 Mb/s	1.152 Mb/s
3 (x4)	1.0 MHz	1.0 MHz	1.0 MHz	1.0 MHz	1.4 MHz	2.8 MHz	13.8 MHz	27.6 MHz
2 (x6)	1.0 MHz	1.0 MHz	1.0 MHz	1.4 MHz	2.1 MHz	4.1 MHz	20.7 MHz	41.5 MHz
1 (x8)	1.0 MHz	1.0 MHz	1.0 MHz	1.0 MHz	1.4 MHz	2.8 MHz	13.8 MHz	27.6 MHz
0 (x16)	1.0 MHz	1.0 MHz	1.0 MHz	1.0 MHz	1.1 MHz	2.2 MHz	11.1 MHz	22.1 MHz

Note that by default, the idle value of the EUSART data signal is high. This means that the IrDA modulator generates negative pulses, and the IrDA demodulator expects negative pulses. To make the IrDA module use RZI signalling, both TXINV and RXINV in EUSARTn_CFG0 must be set.

Since the incoming signal is only sampled on positive clock edges, the width of the incoming pulses must be at least two clk_per periods wide for reliable detection by the receiver.

21.3.2.18.2 IRLF

IRLF only supports RX operation. This feature will stay operational even in EM2. It is possible to cause a wake up when a certain frame is received and then switch to IRHF if TX is required. IRLFEN in IRLFCFG must be set for this to work.

21.3.2.19 DALI operation

EUSART supports DALI (Digitally Addressable Lighting Interface) operation using both HF and LF clocks. DALICFG register holds the configuration for DALI operation. Once DALIEN is set to 1 in DALICFG, DALI mode gets enabled. DALI is available only in EUSART asynchronous mode, i.e., SYNC field in CFG0 register must be set to 0.

21.3.2.19.1 DALI Frame Format

DALI frames are Manchester encoded. Details:

- The TX/RX lines are high when idle.
- The Start bit is Manchester encoded to logic 1.
- Data bits are programmable (from 8-32) and are also Manchester encoded.
- Each DALI frame has two Stop bits, which are represented by a high on the line (same as idle status).
- DALI frame does not have parity bits.

DALI TX and RX data bits are independently programmable (each being from 8 to 32) using DALITXDATABITS and DALIRXDATABITS in the DALICFG register. The DALI bus is half-duplex so everything transmitted on the EUSART DALI TX pin will also show up on EUSART DALI RX pin. In order to ensure that whatever is sent out by EUSART TX is not sampled by EUSART RX, RX enable gets automatically masked to low during an active EUSART transmission. Once the transmission completes, the masking is removed (so if RX was enabled, removing the masking will result in RX getting enabled again and if RX was not enabled, RX enable will stay low even after removing the masking. This feature can be overridden for debugging by setting DALIRXENDT to 1 in DALICFG register. In that case, RX enable will not get masked during EUSART TX (i.e., if EUSART RX was already enabled, it will stay enabled during EUSART TX operation) and whatever is sent out will also be received by EUSART itself. In this case, it is important to set DALIRXDATABITS the same as DALITXDATABITS.

If LOOPBK in CFG0 is set to 1 in order to do loopback testing for DALI, then in this case DALIRXENDT should be set to 1 and DALIRXDATABITS should be set the same as DALITXDATABITS. Advantage of DALI loopback testing is that it can be done without connecting to an actual DALI bus since the data is looped back in from the TX pad.

21.3.2.19.2 DALI Baud Rate Formula

The EUSART clock defines DALI transmission and reception data rate. DALI mode supports any data rate from 300 baud up to 115.2 kbaud. DALI has a baudrate formula that differs from the standard EUSART UART mode baud rate formula. Whenever DALIEN in DALICFG is set to 1, then the DALI mode is enabled and the baud rate is given by [Figure 21.14 DALI Baud Rate on page 658](#):

$$br = f_{EUSARTn} / (\text{oversample} \times 2 \times (1 + EUSARTn_CLKDIV/256))$$

Figure 21.14. DALI Baud Rate

where $f_{EUSARTn}$ is the peripheral clock frequency and oversample is the oversampling rate as defined by OVS in EUSARTn_CFG0.

Given a desired baud rate $br_{desired}$, the clock divider EUSARTn_CLKDIV can be calculated by using [Figure 21.15 DALI Desired Baud Rate DIV on page 658](#):

$$EUSARTn_CLKDIV = 256 \times (f_{EUSARTn} / (\text{oversample} \times 2 \times br_{desired}) - 1)$$

Figure 21.15. DALI Desired Baud Rate DIV

The EUSART DALI mode can tolerate a 10% variation in baud rate as required in the DALI standard.

21.3.2.19.3 DALI Features

DALI mode is enabled by setting DALIEN to 1 in DALICFG register. A limited set of UART mode features are supported in DALI mode. Details below capture the feature set in DALI mode:

- A framing error interrupt (FERRIF) is generated if 2 stop bits are not received at the end of the frame. The received frame is still loaded into the RXDATA register.
- RXDATA and RXDATAP registers serve as RX FIFO. All 16 bits in these registers are treated as data in DALI mode. When DALI is disabled (DALIEN=0) while CFG0.SYNC=0, then these registers contain both data (max 9 bits) and also control information (PERR, FERR).
- When DALIEN is set to 1, then all 16 bits in TXDATA are treated as data. When DALIEN is 0 (DALI mode disabled) and CFG0.SYNC=0, then TXDATA contains both data bits and control bits.
- TXDATA and RXDATA registers are 16 bits wide but the DALI TX and RX data bits can be programmed to be anywhere between 8 and 32. In order to support data bits greater than 16 bits, special programming model applies. Please see the programming model section for details.
- DALI mode is not supported in EM2. TXDMAWU and RXDMAWU in CFG1 register are not supported in DALI mode.
- SKIPERRF feature in CFG0 register is not supported in DALI mode.
- ERRSDMA, ERRSRX and ERRSTX features in CFG0 register are not supported in DALI mode.
- Multiprocessor mode is not supported in DALI mode.
- TX-tristating is not supported in DALI mode. The TX pin is driven high when idle.
- Collision detection is not supported in DALI mode.
- Autobaud detection is not supported in DALI mode.
- Hardware flow control and DBGHALT are not supported in DALI mode.
- RXTIMEOUT and TXDELAY features are not supported in DALI mode.
- Start frame feature is not supported in DALI mode.
- All settings in FRAMECFG are not used in DALI mode. DALICFG register settings are used instead.
- RX blocking feature is not supported in DALI mode.
- IrDA feature (IRLFCFG, IRHFCFG) cannot be enabled while DALI mode is enabled.

21.3.3 Synchronous Operation

Synchronous mode shares some common features with asynchronous mode such as: Loopback, inversion of RX/TX, MSBF, TX/RX Interrupt watermarks. They both share the EUSARTn_TRIGCTRL, CMD, TXDATA, RXDATA, STATUS and Interrupt registers.

In synchronous mode, EUSART can be configured to work either as a main (clock driver) or secondary (clock receiver) interface through EUSARTn_CFG2.MASTER.

21.3.3.1 Frame Format

The frames used in synchronous mode need no start and stop bits since a single clock is available to all parts participating in the communication. Parity bits cannot be used in synchronous mode.

The EUSART supports frame lengths of 8 to 16 bits per frame. Larger frames can be simulated by transmitting multiple smaller frames, i.e. a 22 bit frame can be sent using two 11-bit frames, and a 24 bit frame can be generated by transmitting three 8-bit frames. The number of bits in a frame is set using DATABITS in EUSARTn_FRAMECFG.

The frames in synchronous mode are by default transmitted with the least significant bit first like in asynchronous mode. The bit-order can be reversed by setting MSBF in EUSARTn_CFG0.

The frame format used by the transmitter can be inverted by setting TXINV in EUSARTn_CFG0, and the format expected by the receiver can be inverted by setting RXINV, also in EUSARTn_CFG0.

21.3.3.2 Clock Generation

The bit-rate in synchronous mode is given by [Figure 21.16 EUSART Synchronous Mode Bit Rate on page 660](#). The clock division is derived from EUSARTn_CFG2.SDIV, which is applicable when acting as a Main interface only.

$$br = f_{HFPERCLK} / (1 + EUSARTn_CFG2.SDIV)$$

Figure 21.16. EUSART Synchronous Mode Bit Rate

Given a desired baud rate $br_{desired}$, the clock divider EUSARTn_CFG2.SDIV can be calculated using [Figure 21.17 EUSART Synchronous Mode Clock Division Factor on page 660](#)

$$EUSARTn_CFG2.SDIV = (f_{HFPERCLK} / br_{desired} - 1)$$

Figure 21.17. EUSART Synchronous Mode Clock Division Factor

On every clock edge data on the data lines, MOSI and MISO, is either set up or sampled. When CLKPHA in EUSARTn_CTRL is cleared, data is sampled on the leading clock edge and set-up is done on the trailing edge. If CLKPHA is set however, data is set-up on the leading clock edge, and sampled on the trailing edge. In addition to this, the polarity of the clock signal can be changed by setting CLKPOL in EUSARTn_CTRL, which also defines the idle state of the clock. This results in four different modes which are summarized in [Table 21.11 EUSART SPI Modes on page 660](#). [Figure 21.18 EUSART SPI Timing on page 660](#) shows the resulting timing of data set-up and sampling relative to the bus clock.

Table 21.11. EUSART SPI Modes

SPI mode	CLKPOL	CLKPHA	Leading edge	Trailing edge
0	0	0	Rising, sample	Falling, set-up
1	0	1	Rising, set-up	Falling, sample
2	1	0	Falling, sample	Rising, set-up
3	1	1	Falling, set-up	Rising, sample

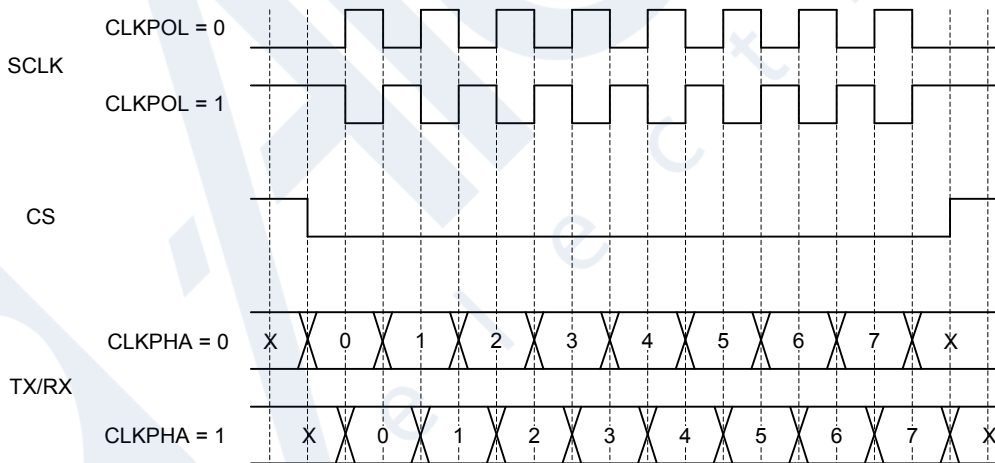

Figure 21.18. EUSART SPI Timing

The RX overflow interrupt flag, RXOF, is set at the end of the overflow frame if the receive FIFO is full. When a transfer has been performed, interrupt flags TXC are updated on the first setup clock edge of the succeeding frame, or when CS is deasserted.

21.3.3.3 Main SPI Interface Mode (Clock Driver)

EUSART operating as a main SPI interface is available only in EM0/EM1 with an HF clock source selected. When configured as a main interface, the EUSART is in full control of the data flow on the synchronous bus. When operating in full duplex mode, the secondary devices cannot transmit data to the main device without the main device transmitting to the secondary. The main device outputs the bus clock on SCLK.

Communication starts whenever there is data in the transmit FIFO and the transmitter is enabled. The EUSART clock then starts, and the main device shifts bits out from the transmit shift register using the internal clock.

When there are no more frames in the transmit FIFO and the transmit shift register is empty, the clock stops, and communication ends. When the receiver is enabled, it samples incoming data when the transmitter transmits data. Operation of the RX and TX FIFOs is as in asynchronous mode.

EUSARTn_CFG2.RXBLOCK can be used to block incoming RX data from pushing into RX FIFO.

21.3.3.4 Operation of CS Pin

When operating as a main interface, the CS pin can have one of two functions, or it can be disabled by clearing CSPEN in GPIO_EUSARn_ROUTEEN register.

If CS is disabled and there is a need to disable TX during the operation, then TX should be disabled at the end of transaction only indicated by the trigger of TXC interrupt to maintain synchronicity between TX and RX and avoid causing sudden stop to secondary devices.

If CS is configured as an output, it can be used to automatically generate a chip select for a single secondary device by setting AUTOCS in EUSARTn_CTRL. If AUTOCS is set, CS is activated before a transmission begins, and deactivated after the last bit has been transmitted and there is no more data in the transmit FIFO.

The time duration between assertion of CS and the start of transmission can be controlled using CSSETUP in EUSARTn_TIMINGCFG. If new data is ready for transmission before CS is deasserted, the data is sent without deasserting CS in between. CSHOLD in EUSARTn_TIMINGCFG keeps CS asserted after the end of frame for the number of baud-times specified.

By default, CS is active low, but its polarity can be inverted by setting CSINV in EUSARTn_CFG2.

21.3.3.5 AUTOTX

The main device on a synchronous bus is required to transmit data (send a clock) to a secondary device in order to receive data from that device. In some cases, only a few words are transmitted and a lot of data is then received from the secondary device. In that case, one solution is to keep feeding the TX with data to transmit, but that consumes system bandwidth. Instead AUTOTX can be used.

When AUTOTX in EUSARTn_CFG2 is set and TX FIFO is filled with initial data, EUSART will fully transmit the loaded data and then continue transmitting the last sent bit as long as there is available space in the RX FIFO for the chosen frame size. This happens even though there is no more data in the TX FIFO. The TX underflow interrupt flag TXUF in EUSARTn_IF is set on the first word that is transmitted which does not contain valid data.

During AUTOTX the EUSART will always send the previous sent bit, thus reducing the number of transitions on the TX output. So if the last bit sent was a 0, 0's will be sent during AUTOTX and if the last bit sent was a 1, 1's will be sent during AUTOTX.

21.3.3.6 Secondary SPI Interface Mode (Clock Receiver)

When the EUSART is in secondary interface mode, data transmission is not controlled by the EUSART, but by an external main SPI device. The EUSART is therefore not able to initiate a transmission, and has no control over the number of bytes written to the external main device.

The output and input to the EUSART are also swapped when in secondary mode, making the receiver take its input from TX (MOSI) and the transmitter drive RX (MISO).

To transmit data when in secondary mode, the device must load data into the transmit FIFO and enable the transmitter. The data will remain in the EUSART until the main device starts a transmission by pulling the CS input low and transmitting data. For every frame transmitted from main to secondary device, a frame is transferred from secondary to main as well.

If the transmitter is enabled in synchronous secondary mode and the main device starts transmission of a frame, the underflow interrupt flag TXUF in EUSARTn_IF will be set if no data is available for transmission. At the same time, the secondary device will transmit the default TX data, which can be set through EUSARTn_DTXDATCFG for the current and subsequent frames until the FIFO is filled. Note that when TX is enabled (with or without data in TXFIFO) in the middle of transaction, TXUF can be triggered if it's transmitting default TX data.

Similar to when operating as a synchronous main interface, EUSARTn_CFG2.RXBLOCK can be used to block incoming RX data from pushing into RX FIFO.

If the secondary device needs to control its own chip select signal, this can be achieved by clearing CSPEN in the GPIO_EUSARTn_ROUTEEN register. The internal chip select signal can then be controlled through CSINV in the CTRL register. The chip select signal will be CSINV inverted, i.e. if CSINV is cleared, the chip select is active and vice versa. In such cases, SCLK could arrive any-time that the device doesn't have prior notification from CS. Hence, EUSARTn_CFG2.FORCELOAD bit can be used to control how the device transmits the first dataword. If this bit is not set, the next outgoing dataword will be a DEFAULT TX data even if the FIFO had been loaded before SCLK arrives, followed by the loaded TX data. EUSARTn_IF.LOADERRIF Interrupt will never be triggered when EUSARTn_CFG2.FORCELOAD is not set. If this bit is set, as soon as the transmitter becomes ready the shift register will be loaded immediately and send data once SCLK arrives. The transmitter becomes ready when TX is enabled and TXFIFO is filled. On top of that, at word-boundary it will automatically trigger setup window check against the programmed EUSARTn_TIMINGCFG.SETUPWINDOW, which specifies the minimum duration (in APB bus clock cycles) between transmitter becoming ready and the incoming SCLK. If the measured duration is less than SETUPWINDOW bus clock cycles, an EUSARTn_IF.LOADERRIF Interrupt will be triggered. Besides, if the transmitter is enabled or disabled or the empty TXFIFO is loaded not at word-boundary during a transaction (SCLK is toggling), LOADERRIF will also be triggered immediately without checking for SETUPWINDOW. It's recommended that the transmitter should be ready while SCLK is idling or at word-boundary and at sufficient margin before SCLK toggles. Once LOADERRIF Interrupt is set, it may require to reset the secondary interface by disabling the module and re-enabling it because the transmitted data could be undeterministic.

21.3.4 Debug Halt

When DBGHALT in EUSART_CTRLX is clear, RTS is only dependent on the RX FIFO having space available to receive data. Incoming data is always received until both the RX FIFO is full and the RX shift register is full regardless of the state of DBGHALT or chip halt. Additional incoming data is discarded. When DBGHALT is set, RTS deasserts on RX FIFO full or when chip halt is high. However, a low pulse detected on chip halt will keep RTS asserted when no frame is being received. At the start of frame reception, RTS will deassert if chip halt is high and DBGHALT is set. This behavior allows single stepping to pulse the chip halt low for a cycle, and receive the next frame. The link partner must stop transmitting when RTS is deasserted, or the RX FIFO could overflow. All data in the transmit FIFO is sent out even when chip halt is asserted; therefore, the DMA will need to be set to stop sending the EUSART TX data during chip halt.

21.3.5 PRS-triggered Transmissions

If a transmission must be started on an event with very little delay, the PRS system can be used to trigger the transmission. The PRS channel to use as a trigger can be selected using TSEL in EUSARTn_TRIGCTRL. When a positive edge is detected on this signal, the receiver is enabled if RXTEN in EUSARTn_TRIGCTRL is set, and the transmitter is enabled if TXTEN in EUSARTn_TRIGCTRL is set. Only one signal input is supported by the EUSART.

AUTOTXTEN can also be combined with TXTEN to make the EUSART transmit a command to the external device prior to clocking out data. To do this, disable TX using the TXDIS command, load the TX FIFO with the command and enable AUTOTXTEN and TXTEN. When the selected PRS input goes high, the EUSART will now transmit the loaded command, and then continue clocking out while both the PRS input is high and there is room in the RX FIFO

21.3.6 PRS RX Input

The EUSART can be configured to receive data directly from a PRS channel by setting RXPRS in EUSARTn_INPUT. The PRS channel used is selected using RXPRSEL in EUSARTn_INPUT. This way, for example, a differential RX signal can be input to the ACMP and the output routed via PRS to the EUSART.

21.3.7 PRS CLK Input

The EUSART can be configured to receive clock directly from a PRS channel by setting CLKPRS in EUSARTn_INPUT. The PRS channel used is selected using CLKPRSEL in EUSARTn_INPUT. This is useful in secondary synchronous mode and can together with RX PRS input be used to input data from PRS.

21.3.8 DMA Support

The EUSART has full DMA support. The DMA controller can write to the transmit FIFO using the registers EUSARTn_TXDATA and it can read from the receive FIFO using the registers EUSARTn_RXDATA. This enables single byte transfers, 9 bit data + control/status bits, double byte and double byte + control/status transfers both to and from the EUSART.

A request for the DMA controller to read from the EUSART receive FIFO can come from the following source:

- Receive FIFO level satisfying EUSARTn_CFG1.RXFIW setting

A write request can come from one of the following sources:

- Transmit FIFO level satisfying EUSARTn_CFG1.TXFIW setting.

Even though there are two sources for write requests to the DMA, only one should be used at a time, since the requests from both sources are cleared even though only one of the requests are used.

In some cases, it may be sensible to temporarily stop DMA access to the EUSART when an error such as a framing error has occurred. This is enabled by setting ERRSDMA in EUSARTn_CTRL.

Note: For Synchronous mode full duplex operation, if both receive FIFO and transmit FIFO are served by DMA, to make sure receive FIFO is not overflowed the settings below should be followed.

- The DMA channel that serves receive FIFO should have higher priority than the DMA channel that serves transmit FIFO.
- IGNORESREQ should be set for both DMA channel.

21.4 EUSART Register Map

The offset register address is relative to the registers base address.

Offset	Name	Type	Description
0x000	EUSART_IPVERSION	R	IP Version ID
0x004	EUSART_EN	RW ENABLE	Enable Register
0x008	EUSART_CFG0	RW CONFIG	Configuration 0 Register
0x00C	EUSART_CFG1	RW CONFIG	Configuration 1 Register
0x010	EUSART_CFG2	RW CONFIG	Configuration 2 Register
0x014	EUSART_FRAMECFG	RW CONFIG	Frame Format Register
0x018	EUSART_DTXDATCFG	RW CONFIG	Default TX DATA Register
0x01C	EUSART_IRHFCFG	RW CONFIG	HF IrDA Mod Config Register
0x020	EUSART_IRLFCFG	RW CONFIG	LF IrDA Pulse Config Register
0x024	EUSART_TIMINGCFG	RW CONFIG	Timing Register
0x028	EUSART_STARTFRAMECFG	RW CONFIG	Start Frame Register
0x02C	EUSART_SIGFRAMECFG	RW CONFIG	Signal Frame Register
0x030	EUSART_CLKDIV	RWH LFSYNC	Clock Divider Register
0x034	EUSART_TRIGCTRL	RW LFSYNC	Trigger Control Register
0x038	EUSART_CMD	W LFSYNC	Command Register
0x03C	EUSART_RXDATA	RH	RX Data Register
0x040	EUSART_RXDATAP	RH	RX Data Peek Register
0x044	EUSART_TXDATA	W	TX Data Register
0x048	EUSART_STATUS	RH	Status Register
0x04C	EUSART_IF	RWH INTFLAG	Interrupt Flag Register
0x050	EUSART_IEN	RW	Interrupt Enable Register
0x054	EUSART_SYNCBUSY	RH	Synchronization Busy Register
0x058	EUSART_DALICFG	RW CONFIG	DALI Config Register
0x1000	EUSART_IPVERSION_SET	R	IP Version ID
0x1004	EUSART_EN_SET	RW ENABLE	Enable Register
0x1008	EUSART_CFG0_SET	RW CONFIG	Configuration 0 Register
0x100C	EUSART_CFG1_SET	RW CONFIG	Configuration 1 Register
0x1010	EUSART_CFG2_SET	RW CONFIG	Configuration 2 Register
0x1014	EUSART_FRAMECFG_SET	RW CONFIG	Frame Format Register
0x1018	EUSART_DTXDATCFG_SET	RW CONFIG	Default TX DATA Register
0x101C	EUSART_IRHFCFG_SET	RW CONFIG	HF IrDA Mod Config Register
0x1020	EUSART_IRLFCFG_SET	RW CONFIG	LF IrDA Pulse Config Register
0x1024	EUSART_TIMINGCFG_SET	RW CONFIG	Timing Register
0x1028	EUSART_STARTFRAMECFG_SET	RW CONFIG	Start Frame Register

Offset	Name	Type	Description
0x102C	EUSART_SIGFRAMECFG_SET	RW CONFIG	Signal Frame Register
0x1030	EUSART_CLKDIV_SET	RWH LFSYNC	Clock Divider Register
0x1034	EUSART_TRIGCTRL_SET	RW LFSYNC	Trigger Control Register
0x1038	EUSART_CMD_SET	W LFSYNC	Command Register
0x103C	EUSART_RXDATA_SET	RH	RX Data Register
0x1040	EUSART_RXDATAP_SET	RH	RX Data Peek Register
0x1044	EUSART_TXDATA_SET	W	TX Data Register
0x1048	EUSART_STATUS_SET	RH	Status Register
0x104C	EUSART_IF_SET	RWH INTFLAG	Interrupt Flag Register
0x1050	EUSART_IEN_SET	RW	Interrupt Enable Register
0x1054	EUSART_SYNCBUSY_SET	RH	Synchronization Busy Register
0x1058	EUSART_DALICFG_SET	RW CONFIG	DALI Config Register
0x2000	EUSART_IPVERSION_CLR	R	IP Version ID
0x2004	EUSART_EN_CLR	RW ENABLE	Enable Register
0x2008	EUSART_CFG0_CLR	RW CONFIG	Configuration 0 Register
0x200C	EUSART_CFG1_CLR	RW CONFIG	Configuration 1 Register
0x2010	EUSART_CFG2_CLR	RW CONFIG	Configuration 2 Register
0x2014	EUSART_FRAMECFG_CLR	RW CONFIG	Frame Format Register
0x2018	EUSART_DTXDATCFG_CLR	RW CONFIG	Default TX DATA Register
0x201C	EUSART_IRHFCFG_CLR	RW CONFIG	HF IrDA Mod Config Register
0x2020	EUSART_IRLFCFG_CLR	RW CONFIG	LF IrDA Pulse Config Register
0x2024	EUSART_TIMINGCFG_CLR	RW CONFIG	Timing Register
0x2028	EUSART_STARTFRAMECFG_CLR	RW CONFIG	Start Frame Register
0x202C	EUSART_SIGFRAMECFG_CLR	RW CONFIG	Signal Frame Register
0x2030	EUSART_CLKDIV_CLR	RWH LFSYNC	Clock Divider Register
0x2034	EUSART_TRIGCTRL_CLR	RW LFSYNC	Trigger Control Register
0x2038	EUSART_CMD_CLR	W LFSYNC	Command Register
0x203C	EUSART_RXDATA_CLR	RH	RX Data Register
0x2040	EUSART_RXDATAP_CLR	RH	RX Data Peek Register
0x2044	EUSART_TXDATA_CLR	W	TX Data Register
0x2048	EUSART_STATUS_CLR	RH	Status Register
0x204C	EUSART_IF_CLR	RWH INTFLAG	Interrupt Flag Register
0x2050	EUSART_IEN_CLR	RW	Interrupt Enable Register
0x2054	EUSART_SYNCBUSY_CLR	RH	Synchronization Busy Register
0x2058	EUSART_DALICFG_CLR	RW CONFIG	DALI Config Register
0x3000	EUSART_IPVERSION_TGL	R	IP Version ID

Offset	Name	Type	Description
0x3004	EUSART_EN_TGL	RW ENABLE	Enable Register
0x3008	EUSART_CFG0_TGL	RW CONFIG	Configuration 0 Register
0x300C	EUSART_CFG1_TGL	RW CONFIG	Configuration 1 Register
0x3010	EUSART_CFG2_TGL	RW CONFIG	Configuration 2 Register
0x3014	EUSART_FRAMECFG_TGL	RW CONFIG	Frame Format Register
0x3018	EUSART_DTXDATCFG_TGL	RW CONFIG	Default TX DATA Register
0x301C	EUSART_IRHFCFG_TGL	RW CONFIG	HF IrDA Mod Config Register
0x3020	EUSART_IRLFCFG_TGL	RW CONFIG	LF IrDA Pulse Config Register
0x3024	EUSART_TIMINGCFG_TGL	RW CONFIG	Timing Register
0x3028	EUSART_STARTFRAMECFG_TGL	RW CONFIG	Start Frame Register
0x302C	EUSART_SIGFRAMECFG_TGL	RW CONFIG	Signal Frame Register
0x3030	EUSART_CLKDIV_TGL	RWH LFSYNC	Clock Divider Register
0x3034	EUSART_TRIGCTRL_TGL	RW LFSYNC	Trigger Control Register
0x3038	EUSART_CMD_TGL	W LFSYNC	Command Register
0x303C	EUSART_RXDATA_TGL	RH	RX Data Register
0x3040	EUSART_RXDATAP_TGL	RH	RX Data Peek Register
0x3044	EUSART_TXDATA_TGL	W	TX Data Register
0x3048	EUSART_STATUS_TGL	RH	Status Register
0x304C	EUSART_IF_TGL	RWH INTFLAG	Interrupt Flag Register
0x3050	EUSART_IEN_TGL	RW	Interrupt Enable Register
0x3054	EUSART_SYNCBUSY_TGL	RH	Synchronization Busy Register
0x3058	EUSART_DALICFG_TGL	RW CONFIG	DALI Config Register

21.5 EUSART Register Description

21.5.1 EUSART_IPVERSION - IP Version ID

Offset	Bit Position																															
0x000	31	30	29	28	27	26	25	24	23	22	21	20	19	18	17	16	15	14	13	12	11	10	9	8	7	6	5	4	3	2	1	0
Reset	0x2																															
Access	R																															
Name	IPVERSION																															

Bit	Name	Reset	Access	Description
31:0	IPVERSION	0x2	R	IP version ID
The read only IPVERSION field gives the version for this module. There may be minor software changes required for modules with different values of IPVERSION.				

21.5.2 EUSART_EN - Enable Register

Offset	Bit Position																															
0x004	31	30	29	28	27	26	25	24	23	22	21	20	19	18	17	16	15	14	13	12	11	10	9	8	7	6	5	4	3	2	1	0
Reset																															0x0	0x0
Access																															R	RW
Name																															DISABLING	EN

Bit	Name	Reset	Access	Description
31:2	<i>Reserved</i>	<i>To ensure compatibility with future devices, always write Reserved bits to their reset value, unless otherwise stated. More information in 1.2 Conventions</i>		
1	DISABLING	0x0	R	Disablement busy status Disablement status when the module is disabled.
0	EN	0x0	RW	Module enable Set to enable the module.

21.5.3 EUSART_CFG0 - Configuration 0 Register

Offset	Bit Position																																	
0x008	31	30	29	28	27	26	25	24	23	22	21	20	19	18	17	16	15	14	13	12	11	10	9	8	7	6	5	4	3	2	1	0		
Reset	0x0	0x0						0x0	0x0	0x0		0x0			0x0			0x0	0x0			0x0				0x0			0x0	0x0	0x0	0x0	0x0	0x0
Access	RW	RW						RW	RW	RW		RW			RW			RW	RW			RW				RW			RW	RW	RW	RW	RW	RW
Name	AUTOBAUDEN	MVDIS						ERRSTX	ERRSRX	ERRSDMA		SKIPPERRF			AUTOTRI			TXINV	RXINV			MSBF				OVS			MPAB	MPM	CCEN	LOOPBK	SYNC	

Bit	Name	Reset	Access	Description									
31	AUTOBAUDEN	0x0	RW	AUTOBAUD detection enable Detects the baud rate based on receiving a 0x55 frame (0x00 for IrDA). Only applicable when CFG0.SYNC bit is set to 'ASYNC'.									
30	MVDIS	0x0	RW	Majority Vote Disable Disable majority vote for 16x, 8x and 6x oversampling modes. Only applicable when CFG0.SYNC bit is set to 'ASYNC'.									
29:25	<i>Reserved</i>	<i>To ensure compatibility with future devices, always write Reserved bits to their reset value, unless otherwise stated. More information in 1.2 Conventions</i>											
24	ERRSTX	0x0	RW	Disable TX On Error When set, the transmitter is disabled on framing and parity errors in the receiver. Only applicable when CFG0.SYNC bit is set to 'ASYNC'. <table border="1" style="width: 100%; border-collapse: collapse;"> <thead> <tr> <th>Value</th> <th>Mode</th> <th>Description</th> </tr> </thead> <tbody> <tr> <td>0</td> <td>DISABLE</td> <td>Received framing and parity errors have no effect on transmitter</td> </tr> <tr> <td>1</td> <td>ENABLE</td> <td>Received framing and parity errors disable the transmitter</td> </tr> </tbody> </table>	Value	Mode	Description	0	DISABLE	Received framing and parity errors have no effect on transmitter	1	ENABLE	Received framing and parity errors disable the transmitter
Value	Mode	Description											
0	DISABLE	Received framing and parity errors have no effect on transmitter											
1	ENABLE	Received framing and parity errors disable the transmitter											
23	ERRSRX	0x0	RW	Disable RX On Error When set, the receiver is disabled on framing and parity errors. Only applicable when CFG0.SYNC bit is set to 'ASYNC'. <table border="1" style="width: 100%; border-collapse: collapse;"> <thead> <tr> <th>Value</th> <th>Mode</th> <th>Description</th> </tr> </thead> <tbody> <tr> <td>0</td> <td>DISABLE</td> <td>Framing and parity errors have no effect on receiver</td> </tr> <tr> <td>1</td> <td>ENABLE</td> <td>Framing and parity errors disable the receiver</td> </tr> </tbody> </table>	Value	Mode	Description	0	DISABLE	Framing and parity errors have no effect on receiver	1	ENABLE	Framing and parity errors disable the receiver
Value	Mode	Description											
0	DISABLE	Framing and parity errors have no effect on receiver											
1	ENABLE	Framing and parity errors disable the receiver											
22	ERRSDMA	0x0	RW	Halt DMA Read On Error When set, DMA read requests will be cleared on framing and parity errors. Only applicable when CFG0.SYNC bit is set to 'ASYNC'. <table border="1" style="width: 100%; border-collapse: collapse;"> <thead> <tr> <th>Value</th> <th>Mode</th> <th>Description</th> </tr> </thead> <tbody> <tr> <td>0</td> <td>DISABLE</td> <td>Framing and parity errors have no effect on DMA requests from the EUSART</td> </tr> <tr> <td>1</td> <td>ENABLE</td> <td>DMA requests from the EUSART are blocked while the PERR or FERR interrupt flags are set</td> </tr> </tbody> </table>	Value	Mode	Description	0	DISABLE	Framing and parity errors have no effect on DMA requests from the EUSART	1	ENABLE	DMA requests from the EUSART are blocked while the PERR or FERR interrupt flags are set
Value	Mode	Description											
0	DISABLE	Framing and parity errors have no effect on DMA requests from the EUSART											
1	ENABLE	DMA requests from the EUSART are blocked while the PERR or FERR interrupt flags are set											
21	<i>Reserved</i>	<i>To ensure compatibility with future devices, always write Reserved bits to their reset value, unless otherwise stated. More information in 1.2 Conventions</i>											

Bit	Name	Reset	Access	Description
20	SKIPPERRF	0x0	RW	Skip Parity Error Frames When set, the receiver discards frames with parity errors. The PERR interrupt flag is still set. Only applicable when CFG0.SYNC bit is set to 'ASYNC'.
19:18	<i>Reserved</i>	<i>To ensure compatibility with future devices, always write Reserved bits to their reset value, unless otherwise stated. More information in 1.2 Conventions</i>		
17	AUTOTRI	0x0	RW	Automatic TX Tristate When enabled, TXTRI is set by hardware whenever the transmitter is idle, and TXTRI is cleared by hardware when transmission starts. Only applicable when CFG0.SYNC bit is set to 'ASYNC'.
	Value	Mode	Description	
	0	DISABLE	The output on UARTn_TX when the transmitter is idle is defined by TXINV	
	1	ENABLE	UARTn_TX is tristated whenever the transmitter is idle	
16:15	<i>Reserved</i>	<i>To ensure compatibility with future devices, always write Reserved bits to their reset value, unless otherwise stated. More information in 1.2 Conventions</i>		
14	TXINV	0x0	RW	Transmitter output Invert The output from the EUSART transmitter can optionally be inverted by setting this bit.
	Value	Mode	Description	
	0	DISABLE	Output from the transmitter is passed unchanged to UARTn_TX	
	1	ENABLE	Output from the transmitter is inverted before it is passed to UARTn_TX	
13	RXINV	0x0	RW	Receiver Input Invert Setting this bit will invert the input to the EUSART receiver.
	Value	Mode	Description	
	0	DISABLE	Input is passed directly to the receiver	
	1	ENABLE	Input is inverted before it is passed to the receiver	
12:11	<i>Reserved</i>	<i>To ensure compatibility with future devices, always write Reserved bits to their reset value, unless otherwise stated. More information in 1.2 Conventions</i>		
10	MSBF	0x0	RW	Most Significant Bit First Decides whether data is sent with the least significant bit first, or the most significant bit first.
	Value	Mode	Description	
	0	DISABLE	Data is sent with the least significant bit first	
	1	ENABLE	Data is sent with the most significant bit first	
9:8	<i>Reserved</i>	<i>To ensure compatibility with future devices, always write Reserved bits to their reset value, unless otherwise stated. More information in 1.2 Conventions</i>		
7:5	OVS	0x0	RW	Oversampling Sets the number of clock periods in a EUSART bit-period. More clock cycles gives better robustness, while less clock cycles gives better performance. Only applicable when CFG0.SYNC bit is set to 'ASYNC'.
	Value	Mode	Description	

Bit	Name	Reset	Access	Description
	0	X16		16X oversampling
	1	X8		8X oversampling
	2	X6		6X oversampling
	3	X4		4X oversampling
	4	DISABLE		Disable oversampling (for LF operation)
4	MPAB	0x0	RW	Multi-Processor Address-Bit Defines the value of the multi-processor address bit. An incoming frame with its 9th bit equal to the value of this bit marks the frame as a multi-processor address frame. Only applicable when CFG0.SYNC bit is set to 'ASYNC'.
3	MPM	0x0	RW	Multi-Processor Mode Multi-processor mode uses the 9th bit of the EUSART frames to tell whether the frame is an address frame or a data frame. Only applicable when CFG0.SYNC bit is set to 'ASYNC'.
	Value	Mode		Description
	0	DISABLE		The 9th bit of incoming frames has no special function
	1	ENABLE		An incoming frame with the 9th bit equal to MPAB will be loaded into the RX FIFO regardless of RXBLOCK and will result in the MPAB interrupt flag being set
2	CCEN	0x0	RW	Collision Check Enable Enables collision checking on data when operating in half duplex modus. Only applicable when CFG0.SYNC bit is set to 'ASYNC'.
	Value	Mode		Description
	0	DISABLE		Collision check is disabled
	1	ENABLE		Collision check is enabled. The receiver must be enabled for the check to be performed
1	LOOPBK	0x0	RW	Loopback Enable Allows the receiver to be connected directly to the EUSART transmitter for loopback and half duplex communication.
	Value	Mode		Description
	0	DISABLE		The receiver is connected to and receives data from UARTn_RX
	1	ENABLE		The receiver is connected to and receives data from UARTn_TX
0	SYNC	0x0	RW	Synchronous Mode Determines whether the EUSART is operating in asynchronous or synchronous mode. When switching between SYNC and ASYNC mode, module Disablement is required.
	Value	Mode		Description
	0	ASYNC		The EUSART operates in asynchronous mode
	1	SYNC		The EUSART operates in synchronous mode

21.5.4 EUSART_CFG1 - Configuration 1 Register

Offset	Bit Position																																	
0x00C	31	30	29	28	27	26	25	24	23	22	21	20	19	18	17	16	15	14	13	12	11	10	9	8	7	6	5	4	3	2	1	0		
Reset			0x0					0x0						0x0			0x0					0x0					0x0			0x0			0x0	
Access			RW					RW						RW			RW					RW	RW	RW				RW			RW	RW	RW	RW
Name			RXFIW					RTSRXFW						TXFIW			RXPRSEN					SFUBRX	RXDMAWU	TXDMAWU				RXTIMEOUT			RTSINV	CTSEN	CTSINV	DBGHALT

Bit	Name	Reset	Access	Description
31	<i>Reserved</i>			<i>To ensure compatibility with future devices, always write Reserved bits to their reset value, unless otherwise stated. More information in 1.2 Conventions</i>
30:27	RXFIW	0x0	RW	RX FIFO Interrupt Watermark Determines the interrupt and status level of the Receive FIFO. Also impacts RX DMA request.
	Value	Mode		Description
	0	ONEFRAME		RXFL status flag and IF are set when the RX FIFO has at least one frame in it.
	1	TWOFRAMES		RXFL status flag and IF are set when the RX FIFO has at least two frames in it.
	2	THREEFRAMES		RXFL status flag and IF are set when the RX FIFO has at least three frames in it.
	3	FOURFRAMES		RXFL status flag and IF are set when the RX FIFO has at least four frames in it.
	4	FIVEFRAMES		RXFL status flag and IF are set when the RX FIFO has at least five frames in it.
	5	SIXFRAMES		RXFL status flag and IF are set when the RX FIFO has at least six frames in it.
	6	SEVENFRAMES		RXFL status flag and IF are set when the RX FIFO has at least seven frames in it.
	7	EIGHTFRAMES		RXFL status flag and IF are set when the RX FIFO has at least eight frames in it.
	8	NINEFRAMES		RXFL status flag and IF are set when the RX FIFO has at least nine frames in it.
	9	TENFRAMES		RXFL status flag and IF are set when the RX FIFO has at least ten frames in it.
	10	ELEVENFRAMES		RXFL status flag and IF are set when the RX FIFO has at least eleven frames in it.
	11	TWELVEFRAMES		RXFL status flag and IF are set when the RX FIFO has at least twelve frames in it.
	12	THIRTEENFRAMES		RXFL status flag and IF are set when the RX FIFO has at least thirteen frames in it.
	13	FOURTEENFRAMES		RXFL status flag and IF are set when the RX FIFO has at least fourteen frames in it.

Bit	Name	Reset	Access	Description
14		FIFTEENFRAMES		RXFL status flag and IF are set when the RX FIFO has at least fifteen frames in it.
15		SIXTEENFRAMES		RXFL status flag and IF are set when the RX FIFO has at least sixteen frames in it.
26	<i>Reserved</i>	<i>To ensure compatibility with future devices, always write Reserved bits to their reset value, unless otherwise stated. More information in 1.2 Conventions</i>		
25:22	RTSRXFW	0x0	RW	Request-to-send RX FIFO Watermark Set Request-to-send watermark level. Only applicable when CFG0.SYNC bit is set to 'ASYNC'.
	Value	Mode	Description	
	0	ONEFRAME	RTS is set if there is space for at least one more frame in the RX FIFO.	
	1	TWOFRAMES	RTS is set if there is space for at least two more frames in the RX FIFO.	
	2	THREEFRAMES	RTS is set if there is space for at least three more frames in the RX FIFO.	
	3	FOURFRAMES	RTS is set if there is space for four more frames in the RX FIFO.	
	4	FIVEFRAMES	RTS is set if there is space for five more frames in the RX FIFO.	
	5	SIXFRAMES	RTS is set if there is space for six more frames in the RX FIFO.	
	6	SEVENFRAMES	RTS is set if there is space for seven more frames in the RX FIFO.	
	7	EIGHTFRAMES	RTS is set if there is space for eight more frames in the RX FIFO.	
	8	NINEFRAMES	RTS is set if there is space for nine more frames in the RX FIFO.	
	9	TENFRAMES	RTS is set if there is space for ten more frames in the RX FIFO.	
	10	ELEVENFRAMES	RTS is set if there is space for eleven more frames in the RX FIFO.	
	11	TWELVEFRAMES	RTS is set if there is space for twelve more frames in the RX FIFO.	
	12	THIRTEENFRAMES	RTS is set if there is space for thirteen more frames in the RX FIFO.	
	13	FOURTEENFRAMES	RTS is set if there is space for fourteen more frames in the RX FIFO.	
	14	FIFTEENFRAMES	RTS is set if there is space for fifteen more frames in the RX FIFO.	
	15	SIXTEENFRAMES	RTS is set if there is space for sixteen more frames in the RX FIFO.	
21:20	<i>Reserved</i>	<i>To ensure compatibility with future devices, always write Reserved bits to their reset value, unless otherwise stated. More information in 1.2 Conventions</i>		
19:16	TXFIW	0x0	RW	TX FIFO Interrupt Watermark Determines the interrupt and status level of the transmit FIFO. Also impacts TX DMA request.
	Value	Mode	Description	

Bit	Name	Reset	Access	Description
0		ONEFRAME		TXFL status flag and IF are set when the TX FIFO has space for at least one more frame.
1		TWOFRAMES		TXFL status flag and IF are set when the TX FIFO has space for at least two more frames.
2		THREEFRAMES		TXFL status flag and IF are set when the TX FIFO has space for at least three more frames.
3		FOURFRAMES		TXFL status flag and IF are set when the TX FIFO has space for at least four more frames.
4		FIVEFRAMES		TXFL status flag and IF are set when the TX FIFO has space for at least five more frames.
5		SIXFRAMES		TXFL status flag and IF are set when the TX FIFO has space for at least six more frames.
6		SEVENFRAMES		TXFL status flag and IF are set when the TX FIFO has space for at least seven more frames.
7		EIGHTFRAMES		TXFL status flag and IF are set when the TX FIFO has space for at least eight more frames.
8		NINEFRAMES		TXFL status flag and IF are set when the TX FIFO has space for at least nine more frames.
9		TENFRAMES		TXFL status flag and IF are set when the TX FIFO has space for at least ten more frames.
10		ELEVENFRAMES		TXFL status flag and IF are set when the TX FIFO has space for at least eleven more frames.
11		TWELVEFRAMES		TXFL status flag and IF are set when the TX FIFO has space for at least twelve more frames.
12		THIRTEENFRAMES		TXFL status flag and IF are set when the TX FIFO has space for at least thirteen more frames.
13		FOURTEENFRAMES		TXFL status flag and IF are set when the TX FIFO has space for at least fourteen more frames.
14		FIFTEENFRAMES		TXFL status flag and IF are set when the TX FIFO has space for at least fifteen more frames.
15		SIXTEENFRAMES		TXFL status flag and IF are set when the TX FIFO has space for at least sixteen more frames.
15	RXPRSEN	0x0	RW	PRS RX Enable When set, the PRS channel selected as input to RX.
14:12	<i>Reserved</i>	<i>To ensure compatibility with future devices, always write Reserved bits to their reset value, unless otherwise stated. More information in 1.2 Conventions</i>		
11	SFUBRX	0x0	RW	Start Frame Unblock Receiver Set to unblock RX on Start frame reception. Only applicable when CFG0.SYNC bit is set to 'ASYNC'.
10	RXDMAWU	0x0	RW	Receiver DMA Wakeup Set to enable wakeup from EM2 to EM1 for DMA/ RX interaction. Only applicable when CFG0.SYNC bit is set to 'ASYNC'.
9	TXDMAWU	0x0	RW	Transmitter DMA Wakeup Set to enable wakeup from EM2 to EM1 for DMA/ TX interaction. Only applicable when CFG0.SYNC bit is set to 'ASYNC'.

Bit	Name	Reset	Access	Description
8:7	<i>Reserved</i>	<i>To ensure compatibility with future devices, always write Reserved bits to their reset value, unless otherwise stated. More information in 1.2 Conventions</i>		
6:4	RXTIMEOUT	0x0	RW	RX Timeout When enabled, determines how long, in units of frame, RX needs to remain idle after a frame reception before RXTOIF gets set. Only applicable when CFG0.SYNC bit is set to 'ASYNC'.
	Value	Mode	Description	
	0	DISABLED		
	1	ONEFRAME		
	2	TWOFRAMES		
	3	THREEFRAMES		
	4	FOURFRAMES		
	5	FIVEFRAMES		
	6	SIXFRAMES		
	7	SEVENFRAMES		
3	RTSINV	0x0	RW	Request-to-send Invert Enable When set, the RTS pin polarity is inverted. Only applicable when CFG0.SYNC bit is set to 'ASYNC'.
	Value	Mode	Description	
	0	DISABLE	The RTS pin is active low	
	1	ENABLE	The RTS pin is active high	
2	CTSEN	0x0	RW	Clear-to-send Enable When set, frames in the TX FIFO will not be sent until link partner asserts CTS. Any data in the TX shift register will continue transmitting, the next TX FIFO data will not load into the TX shift register. Only applicable when CFG0.SYNC bit is set to 'ASYNC'.
	Value	Mode	Description	
	0	DISABLE	Ignore CTS	
	1	ENABLE	Stop transmitting when CTS is inactive	
1	CTSINV	0x0	RW	Clear-to-send Invert Enable When set, the CTS pin polarity is inverted. Only applicable when CFG0.SYNC bit is set to 'ASYNC'.
	Value	Mode	Description	
	0	DISABLE	The CTS pin is active low	
	1	ENABLE	The CTS pin is active high	
0	DBGHALT	0x0	RW	Debug halt Set to halt operation when core is halted. Only applicable when CFG0.SYNC bit is set to 'ASYNC'.
	Value	Mode	Description	
	0	DISABLE	Continue normal EUSART operation even if core is halted	

Bit	Name	Reset	Access	Description
	1	ENABLE		If core is halted, receive one frame and then halt reception by deactivating RTS. Next frame reception happens when the core is unhalted during single stepping.

21.5.5 EUSART_CFG2 - Configuration 2 Register

Offset	Bit Position																															
0x010	31	30	29	28	27	26	25	24	23	22	21	20	19	18	17	16	15	14	13	12	11	10	9	8	7	6	5	4	3	2	1	0
Reset	0x0												0x0	0x0	0x1	0x0	0x0	0x0	0x0	0x0	0x0	0x0	0x0									
Access	RW												RW	RW	RW	RW	RW	RW	RW	RW	RW											
Name	SDIV												FORCELOAD	CLKPRSEN	AUTOCS	AUTOTX	CSINV	CLKPHA	CLKPOL	MASTER												

Bit	Name	Reset	Access	Description
31:24	SDIV	0x0	RW	Sync Clock Div Sets the clock rate for synchronous main mode operation only (To set the clock rate for asynchronous operation, see the CLKDIV field). Clock division value = SDIV + 1. Only applicable when CFG0.SYNC bit is set to 'SYNC' and CFG2.MASTER is set to 'MASTER'.
23:8	Reserved	To ensure compatibility with future devices, always write Reserved bits to their reset value, unless otherwise stated. More information in 1.2 Conventions		
7	FORCELOAD	0x0	RW	Force Load to Shift Register When this bit is set, if TXEN is already enabled, any loading of an empty FIFO will immediately load the data into the shift register. This bit is recommended to be used in 3-wire setting where CS is not used, or in a custom 4-wire mode where SCLK is in long idle state between two transactions with CS always in active mode (this typically happens between 2 transactions where the main interface holds SCLK idling to give additional time for the secondary interface to load data). If FORCELOAD bit is not set, the next out-going frame will be a DEFAULT TX data, followed by the loaded TX data in TX FIFO. When FORCELOAD is set, it will automatically trigger setup window check against the programmed EUSARTn_TLMINGCFG.SETUPWINDOW, which specifies the minimum duration between empty fifo loading event and first encountered edge of SCLK. If the measured duration is less than SETUPWINDOW bus clock cycles, a EUSARTn_IF.LOADERIF Interrupt will be triggered. Only applicable when CFG0.SYNC bit is set to 'SYNC' and CFG2.MASTER is set to 'SLAVE'.
6	CLKPRSEN	0x0	RW	PRS CLK Enable When set, the PRS channel selected as input to CLK. Only applicable when CFG0.SYNC bit is set to 'SYNC' and CFG2.MASTER is set to 'SLAVE'.
5	AUTOCS	0x1	RW	Automatic Chip Select When enabled, the output on CS will be activated one baud-period before transmission starts, and deactivated when transmission ends. Only applicable when CFG0.SYNC bit is set to 'SYNC' and CFG2.MASTER is set to 'MASTER'.
4	AUTOTX	0x0	RW	Always Transmit When RXFIFO Not Full Transmits as long as RXFIFO is not full. If TX is empty, underflows are generated. Only applicable when CFG0.SYNC bit is set to 'SYNC' and CFG2.MASTER is set to 'MASTER'.
3	CSINV	0x0	RW	Chip Select Invert Default value is active low. This affects both the selection of external secondary devices, as well as the selection of the microcontroller in secondary mode. Only applicable when CFG0.SYNC bit is set to 'SYNC'.
Value		Mode	Description	
0		AL	Chip select is active low	
1		AH	Chip select is active high	
2	CLKPHA	0x0	RW	Clock Edge for Setup/Sample

Bit	Name	Reset	Access	Description
				Determines where data is set-up and sampled according to the bus clock when in synchronous mode. Only applicable when CFG0.SYNC bit is set to 'SYNC'.
	Value	Mode		Description
	0	SAMPLELEADING		Data is sampled on the leading edge and set-up on the trailing edge of the bus clock in synchronous mode
	1	SAMPLETRAILING		Data is set-up on the leading edge and sampled on the trailing edge of the bus clock in synchronous mode
1	CLKPOL	0x0	RW	Clock Polarity
				Determines the clock polarity of the bus clock used in synchronous mode. Only applicable when CFG0.SYNC bit is set to 'SYNC'.
	Value	Mode		Description
	0	IDLELOW		The bus clock used in synchronous mode has a low base value
	1	IDLEHIGH		The bus clock used in synchronous mode has a high base value
0	MASTER	0x0	RW	Main mode
				Set this bit to put EUSART to main interface mode. When unset, EUSART operates in secondary interface mode. When changing between Main and Secondary mode, module Disablement is required. Only applicable when CFG0.SYNC bit is set to 'SYNC'.
	Value	Mode		Description
	0	SLAVE		Secondary mode
	1	MASTER		Main mode

21.5.6 EUSART_FRAMECFG - Frame Format Register

Offset	Bit Position																															
0x014	31	30	29	28	27	26	25	24	23	22	21	20	19	18	17	16	15	14	13	12	11	10	9	8	7	6	5	4	3	2	1	0
Reset																	0x1		0x0			0x2										
Access																	RW		RW			RW										
Name																	STOPBITS		PARITY			DATABITS										

Bit	Name	Reset	Access	Description
31:14	<i>Reserved</i>	<i>To ensure compatibility with future devices, always write Reserved bits to their reset value, unless otherwise stated. More information in 1.2 Conventions</i>		
13:12	STOPBITS	0x1	RW	Stop-Bit Mode Determines the number of stop-bits used. Only applicable when CFG0.SYNC bit is set to 'ASYNC'.
	Value	Mode	Description	
	0	HALF	The transmitter generates a half stop bit. Stop-bits are not verified by receiver	
	1	ONE	One stop bit is generated and verified	
	2	ONEANDAHALF	The transmitter generates one and a half stop bit. The receiver verifies the first stop bit	
	3	TWO	The transmitter generates two stop bits. The receiver checks the first stop-bit only	
11:10	<i>Reserved</i>	<i>To ensure compatibility with future devices, always write Reserved bits to their reset value, unless otherwise stated. More information in 1.2 Conventions</i>		
9:8	PARITY	0x0	RW	Parity-Bit Mode Determines whether parity bits are enabled, and whether even or odd parity should be used. Only applicable when CFG0.SYNC bit is set to 'ASYNC'.
	Value	Mode	Description	
	0	NONE	Parity bits are not used	
	2	EVEN	Even parity are used. Parity bits are automatically generated and checked by hardware.	
	3	ODD	Odd parity is used. Parity bits are automatically generated and checked by hardware.	
7:4	<i>Reserved</i>	<i>To ensure compatibility with future devices, always write Reserved bits to their reset value, unless otherwise stated. More information in 1.2 Conventions</i>		
3:0	DATABITS	0x2	RW	Data-Bit Mode Sets the number of data bits in a EUSART frame.
	Value	Mode	Description	
	1	SEVEN	Each frame contains 7 data bits	
	2	EIGHT	Each frame contains 8 data bits	

Bit	Name	Reset	Access	Description
3		NINE		Each frame contains 9 data bits
4		TEN		Each frame contains 10 data bits
5		ELEVEN		Each frame contains 11 data bits
6		TWELVE		Each frame contains 12 data bits
7		THIRTEEN		Each frame contains 13 data bits
8		FOURTEEN		Each frame contains 14 data bits
9		FIFTEEN		Each frame contains 15 data bits
10		SIXTEEN		Each frame contains 16 data bits

21.5.7 EUSART_DTXDATCFG - Default TX DATA Register

Offset	Bit Position																															
0x018	31	30	29	28	27	26	25	24	23	22	21	20	19	18	17	16	15	14	13	12	11	10	9	8	7	6	5	4	3	2	1	0
Reset																																
Access																																
Name																	DTXDAT															

Bit	Name	Reset	Access	Description
31:16	<i>Reserved</i>	<i>To ensure compatibility with future devices, always write Reserved bits to their reset value, unless otherwise stated. More information in 1.2 Conventions</i>		
15:0	DTXDAT	0x0	RW	Default TX DATA This is the default transmitted data when the TXFIFO is empty. Only applicable when CFG0.SYNC bit is set to 'SYNC' and CFG2.MASTER is set to 'SLAVE'.

21.5.8 EUSART_IRHFCFG - HF IrDA Mod Config Register

Offset	Bit Position																															
0x01C	31	30	29	28	27	26	25	24	23	22	21	20	19	18	17	16	15	14	13	12	11	10	9	8	7	6	5	4	3	2	1	0
Reset																											0x0	0x0	0x0			
Access																											RW	RW	RW			
Name																											IRHFFILT	IRHFPW	IRHFEN			

Bit	Name	Reset	Access	Description															
31:4	<i>Reserved</i>	<i>To ensure compatibility with future devices, always write Reserved bits to their reset value, unless otherwise stated. More information in 1.2 Conventions</i>																	
3	IRHFFILT	0x0	RW	IrDA RX Filter Set to enable filter on demodulator. <table border="1"> <thead> <tr> <th>Value</th> <th>Mode</th> <th>Description</th> </tr> </thead> <tbody> <tr> <td>0</td> <td>DISABLE</td> <td>No filter enabled</td> </tr> <tr> <td>1</td> <td>ENABLE</td> <td>Filter enabled. IrDA pulse must be high for at least 5 consecutive clock cycles to be detected</td> </tr> </tbody> </table>	Value	Mode	Description	0	DISABLE	No filter enabled	1	ENABLE	Filter enabled. IrDA pulse must be high for at least 5 consecutive clock cycles to be detected						
Value	Mode	Description																	
0	DISABLE	No filter enabled																	
1	ENABLE	Filter enabled. IrDA pulse must be high for at least 5 consecutive clock cycles to be detected																	
2:1	IRHFPW	0x0	RW	IrDA TX Pulse Width Configure the pulse width generated by the modulator as a fraction of the configured EUSART bit period. <table border="1"> <thead> <tr> <th>Value</th> <th>Mode</th> <th>Description</th> </tr> </thead> <tbody> <tr> <td>0</td> <td>ONE</td> <td>IrDA pulse width is 1/16 for OVS=0 and 1/8 for OVS=1</td> </tr> <tr> <td>1</td> <td>TWO</td> <td>IrDA pulse width is 2/16 for OVS=0 and 2/8 for OVS=1</td> </tr> <tr> <td>2</td> <td>THREE</td> <td>IrDA pulse width is 3/16 for OVS=0 and 3/8 for OVS=1</td> </tr> <tr> <td>3</td> <td>FOUR</td> <td>IrDA pulse width is 4/16 for OVS=0 and 4/8 for OVS=1</td> </tr> </tbody> </table>	Value	Mode	Description	0	ONE	IrDA pulse width is 1/16 for OVS=0 and 1/8 for OVS=1	1	TWO	IrDA pulse width is 2/16 for OVS=0 and 2/8 for OVS=1	2	THREE	IrDA pulse width is 3/16 for OVS=0 and 3/8 for OVS=1	3	FOUR	IrDA pulse width is 4/16 for OVS=0 and 4/8 for OVS=1
Value	Mode	Description																	
0	ONE	IrDA pulse width is 1/16 for OVS=0 and 1/8 for OVS=1																	
1	TWO	IrDA pulse width is 2/16 for OVS=0 and 2/8 for OVS=1																	
2	THREE	IrDA pulse width is 3/16 for OVS=0 and 3/8 for OVS=1																	
3	FOUR	IrDA pulse width is 4/16 for OVS=0 and 4/8 for OVS=1																	
0	IRHFEN	0x0	RW	Enable IrDA Module Enable IrDA module and route EUSART signals through it. Used when EUSART has HF clock. Only applicable when CFG0.SYNC bit is set to 'ASYNC'															

21.5.9 EUSART_IRLFCFG - LF IrDA Pulse Config Register

Offset	Bit Position																															
0x020	31	30	29	28	27	26	25	24	23	22	21	20	19	18	17	16	15	14	13	12	11	10	9	8	7	6	5	4	3	2	1	0
Reset																																0x0
Access																																RW
Name																																IRLFEN

Bit	Name	Reset	Access	Description
31:1	<i>Reserved</i>	<i>To ensure compatibility with future devices, always write Reserved bits to their reset value, unless otherwise stated. More information in 1.2 Conventions</i>		
0	IRLFEN	0x0	RW	Pulse Generator/Extender Enable Filter EUSART output through pulse generator and the EUSART input through the pulse extender. Used for LF operation. Only applicable when CFG0.SYNC bit is set to 'ASYNC'

21.5.10 EUSART_TIMINGCFG - Timing Register

Offset	Bit Position																																	
0x024	31	30	29	28	27	26	25	24	23	22	21	20	19	18	17	16	15	14	13	12	11	10	9	8	7	6	5	4	3	2	1	0		
Reset																	0x5				0x0				0x0				0x0				0x0	
Access																	RW				RW				RW				RW				RW	
Name																	SETUPWINDOW				ICS				CSHOLD				CSSETUP				TXDELAY	

Bit	Name	Reset	Access	Description
31:20	<i>Reserved</i>	<i>To ensure compatibility with future devices, always write Reserved bits to their reset value, unless otherwise stated. More information in 1.2 Conventions</i>		
19:16	SETUPWINDOW	0x5	RW	Setup Window When CFG2.FORCELOAD is set, this defines the number of bus clock cycles that empty FIFO load or enabling of TX or disabling of TX must be performed before the sampling edge of SCLK at word-boundary to avoid load error. Word boundary is defined as followings: before the transaction starts, or between 2 transactions or the first bit between 2 datawords. If baud-rate is more than 5 MHz, a value of 4 is recommended, any values smaller than that can be tried out but avoid using 0. If baud-rate is less than 5 MHz, value of 5 is recommended, any values higher than 5 can be used but it may make the load error easy to occur. The recommended values for frequency bands should be sufficient to work all the time. Only applicable when CFG0.SYNC bit is set to 'SYNC' and CFG2.MASTER is set to 'SLAVE' and CFG2.FORCELOAD is set.
15	<i>Reserved</i>	<i>To ensure compatibility with future devices, always write Reserved bits to their reset value, unless otherwise stated. More information in 1.2 Conventions</i>		
14:12	ICS	0x0	RW	Inter-Character Spacing Inter-character spacing after each TX frame while the TX FIFO is not empty. Only applicable when CFG0.SYNC bit is set to 'SYNC' and CFG2.MASTER is set to 'MASTER'.
	Value	Mode	Description	
	0	ZERO	There is no space between charcters	
	1	ONE	Create a space of 1 baud-times between frames	
	2	TWO	Create a space of 2 baud-times between frames	
	3	THREE	Create a space of 3 baud-times between frames	
	4	FOUR	Create a space of 4 baud-times between frames	
	5	FIVE	Create a space of 5 baud-times between frames	
	6	SIX	Create a space of 6 baud-times between frames	
	7	SEVEN	Create a space of 7 baud-times between frames	
11	<i>Reserved</i>	<i>To ensure compatibility with future devices, always write Reserved bits to their reset value, unless otherwise stated. More information in 1.2 Conventions</i>		
10:8	CSHOLD	0x0	RW	Chip Select Hold Chip Select will be de-asserted after the end of frame transmission. Only applicable when CFG0.SYNC bit is set to 'SYNC' and CFG2.MASTER is set to 'MASTER'.
	Value	Mode	Description	

Bit	Name	Reset	Access	Description
0		ZERO		CS is de-asserted half or 1 baud-time after the end of transmission depending on CLKPHASE equal to 1 or 0 respectively
1		ONE		CS is de-asserted 1 additional baud-time after the end of transmission
2		TWO		CS is de-asserted 2 additional baud-times after the end of transmission
3		THREE		CS is de-asserted 3 additional baud-times after the end of transmission
4		FOUR		CS is de-asserted 4 additional baud-times after the end of transmission
5		FIVE		CS is de-asserted 5 additional baud-times after the end of transmission
6		SIX		CS is de-asserted 6 additional baud-times after the end of transmission
7		SEVEN		CS is de-asserted 7 additional baud-times after the end of transmission
7	<i>Reserved</i>	<i>To ensure compatibility with future devices, always write Reserved bits to their reset value, unless otherwise stated. More information in 1.2 Conventions</i>		
6:4	CSSETUP	0x0	RW	Chip Select Setup
	Chip Select will be asserted before the start of frame transmission. Only applicable when CFG0.SYNC bit is set to 'SYNC' and CFG2.MASTER is set to 'MASTER'.			
	Value	Mode	Description	
	0	ZERO	CS is asserted half or 1 baud-time before the start of transmission depending on CLKPHASE equal to 1 or 0 respectively	
	1	ONE	CS is asserted 1 additional baud-time before start of transmission	
	2	TWO	CS is asserted 2 additional baud-times before start of transmission	
	3	THREE	CS is asserted 3 additional baud-times before start of transmission	
	4	FOUR	CS is asserted 4 additional baud-times before start of transmission	
	5	FIVE	CS is asserted 5 additional baud-times before start of transmission	
	6	SIX	CS is asserted 6 additional baud-times before start of transmission	
	7	SEVEN	CS is asserted 7 additional baud-times before start of transmission	
3:2	<i>Reserved</i>	<i>To ensure compatibility with future devices, always write Reserved bits to their reset value, unless otherwise stated. More information in 1.2 Conventions</i>		
1:0	TXDELAY	0x0	RW	TX Delay Transmission
	Configurable delay before new transfers. Frames sent back-to-back are not delayed. Only applicable when CFG0.SYNC bit is set to 'ASYNCR'.			
	Value	Mode	Description	

Bit	Name	Reset	Access	Description
0		NONE		Frames are transmitted immediately.
1		SINGLE		Transmission of new frames is delayed by a single bit period.
2		DOUBLE		Transmission of new frames is delayed by a two bit periods.
3		TRIPPLE		Transmission of new frames is delayed by a three bit periods.

21.5.11 EUSART_STARTFRAMECFG - Start Frame Register

Offset	Bit Position																															
0x028	31	30	29	28	27	26	25	24	23	22	21	20	19	18	17	16	15	14	13	12	11	10	9	8	7	6	5	4	3	2	1	0
Reset																																0x0
Access																																RW
Name																																STARTFRAME

Bit	Name	Reset	Access	Description
31:9	<i>Reserved</i>	<i>To ensure compatibility with future devices, always write Reserved bits to their reset value, unless otherwise stated. More information in 1.2 Conventions</i>		
8:0	STARTFRAME	0x0	RW	Start Frame When a frame matching STARTFRAME is received, the receiver detects that and STARTF interrupt flag is set. If SFUBRX is set, RXBLOCK is cleared and the start frame is loaded in to the RX FIFO. Only applicable when CFG0.SYNC bit is set to 'ASYNc'.

21.5.12 EUSART_SIGFRAMECFG - Signal Frame Register

Offset	Bit Position																															
0x02C	31	30	29	28	27	26	25	24	23	22	21	20	19	18	17	16	15	14	13	12	11	10	9	8	7	6	5	4	3	2	1	0
Reset																																0x0
Access																																RW
Name																																SIGFRAME

Bit	Name	Reset	Access	Description
31:0	SIGFRAME	0x0	RW	Signal Frame Value When a frame matching SIGFRAME is detected by the receiver, SIGF interrupt flag is set. Only applicable when CFG0.SYNC bit is set to 'ASYNc'.

21.5.13 EUSART_CLKDIV - Clock Divider Register

Offset	Bit Position																															
0x030	31	30	29	28	27	26	25	24	23	22	21	20	19	18	17	16	15	14	13	12	11	10	9	8	7	6	5	4	3	2	1	0
Reset												0x0																				
Access												RW																				
Name												DIV																				

Bit	Name	Reset	Access	Description
31:23	Reserved	To ensure compatibility with future devices, always write Reserved bits to their reset value, unless otherwise stated. More information in 1.2 Conventions		
22:3	DIV	0x0	RW	Fractional Clock Divider Specifies the fractional clock divider. Setting AUTOBAUDEN in CFG1 register will overwrite the DIV field. Only applicable when CFG0.SYNC bit is set to 'ASYNC'.
2:0	Reserved	To ensure compatibility with future devices, always write Reserved bits to their reset value, unless otherwise stated. More information in 1.2 Conventions		

21.5.14 EUSART_TRIGCTRL - Trigger Control Register

Offset	Bit Position																															
0x034	31	30	29	28	27	26	25	24	23	22	21	20	19	18	17	16	15	14	13	12	11	10	9	8	7	6	5	4	3	2	1	0
Reset																										0x0	0x0	0x0				
Access																										RW	RW	RW				
Name																										AUTOTXTEN	TXTEN	RXTEN				

Bit	Name	Reset	Access	Description
31:3	Reserved	To ensure compatibility with future devices, always write Reserved bits to their reset value, unless otherwise stated. More information in 1.2 Conventions		
2	AUTOTXTEN	0x0	RW	AUTOTX Trigger Enable When set, AUTOTX is enabled as long as the selected PRS channel has a high value. Only applicable when CFG0.SYNC bit is set to 'SYNC' and CFG2.MASTER is set to 'MASTER'.
1	TXTEN	0x0	RW	Transmit Trigger Enable When set, the positive edge of the selected PRS channel sets TXEN, enabling the transmitter.
0	RXTEN	0x0	RW	Receive Trigger Enable When set, the positive edge of the selected PRS channel sets RXEN, enabling the receiver.

21.5.15 EUSART_CMD - Command Register

Offset	Bit Position																																																				
0x038	31	30	29	28	27	26	25	24	23	22	21	20	19	18	17	16	15	14	13	12	11	10	9	8	7	6	5	4	3	2	1	0																					
Reset																								0x0	0x0	0x0	0x0	0x0	0x0	0x0	0x0	0x0	0x0	0x0	0x0	0x0	0x0	0x0	0x0	0x0	0x0	0x0	0x0	0x0	0x0	0x0	0x0	0x0	0x0	0x0	0x0	0x0	0x0
Access																								W(nB)	W(nB)	W(nB)	W(nB)	W(nB)	W(nB)	W(nB)	W(nB)	W(nB)	W(nB)	W(nB)	W(nB)	W(nB)	W(nB)	W(nB)	W(nB)	W(nB)	W(nB)	W(nB)	W(nB)	W(nB)	W(nB)	W(nB)	W(nB)	W(nB)	W(nB)	W(nB)	W(nB)	W(nB)	W(nB)
Name																								CLEARTX	TXTRIDIS	TXTRIEN	RXBLOCKDIS	RXBLOCKEN	TXDIS	TXEN	RXDIS	RXEN																					

Bit	Name	Reset	Access	Description
31:9	<i>Reserved</i>	<i>To ensure compatibility with future devices, always write Reserved bits to their reset value, unless otherwise stated. More information in 1.2 Conventions</i>		
8	CLEARTX	0x0	W(nB)	Clear TX FIFO Set to clear TX FIFO. Only applicable when CFG0.SYNC bit is set to 'ASYNCR'. Note that before issuing this command, firmware should first set the transmitter disable bit (CMD.TXDIS) and then poll the transmitter enable status bit until cleared (STATUS.TXENS).
7	TXTRIDIS	0x0	W(nB)	Transmitter Tristate Disable Disables tristating of the transmitter output.
6	TXTRIEN	0x0	W(nB)	Transmitter Tristate Enable Tristates the transmitter output. Only applicable when CFG0.SYNC bit is set to 'ASYNCR'.
5	RXBLOCKDIS	0x0	W(nB)	Receiver Block Disable Set to clear RXBLOCK, resulting in all incoming frames being loaded into the RX FIFO.
4	RXBLOCKEN	0x0	W(nB)	Receiver Block Enable Set to set RXBLOCK, resulting in all incoming frames being discarded.
3	TXDIS	0x0	W(nB)	Transmitter Disable Set to disable transmission. STATUS.TXENS should be polled to ensure disabled status in Synchronous mode.
2	TXEN	0x0	W(nB)	Transmitter Enable Set to enable data transmission. STATUS.TXENS should be polled to ensure enabled status in Synchronous mode.
1	RXDIS	0x0	W(nB)	Receiver Disable Set to disable data reception. If a frame is under reception when the receiver is disabled, the incoming frame is discarded. STATUS.RXENS should be polled to ensure disabled status in Synchronous mode.
0	RXEN	0x0	W(nB)	Receiver Enable Set to activate data reception. STATUS.RXENS should be polled to ensure enabled status in Synchronous mode.

21.5.16 EUSART_RXDATA - RX Data Register

Offset	Bit Position																															
0x03C	31	30	29	28	27	26	25	24	23	22	21	20	19	18	17	16	15	14	13	12	11	10	9	8	7	6	5	4	3	2	1	0
Reset																	0x0															
Access																	R															
Name																	RXDATA															

Bit	Name	Reset	Access	Description
31:16	Reserved			To ensure compatibility with future devices, always write Reserved bits to their reset value, unless otherwise stated. More information in 1.2 Conventions
15:0	RXDATA	0x0	R	RX Data and Control bits

Use this register to access data read from the EUSART, cleared on read access. In Synchronous mode, Bit 15:0 is actual RXDATA. In Asynchronous mode, if DALICFG.DALIEN is 0, then Bit 8:0 is actual RXDATA, bit 9 is PERR (set if received data has a parity error.), bit 10 is FERR (set if received data has a framing error, can be result of a break condition). In Asynchronous mode, if DALICFG.DALIEN is set to 1, then all 16 bits represent received data. Note that FIFO is not retained in EM2.

21.5.17 EUSART_RXDATAP - RX Data Peek Register

Offset	Bit Position																															
0x040	31	30	29	28	27	26	25	24	23	22	21	20	19	18	17	16	15	14	13	12	11	10	9	8	7	6	5	4	3	2	1	0
Reset																	0x0															
Access																	R															
Name																	RXDATAP															

Bit	Name	Reset	Access	Description
31:16	Reserved			To ensure compatibility with future devices, always write Reserved bits to their reset value, unless otherwise stated. More information in 1.2 Conventions
15:0	RXDATAP	0x0	R	RX Data Peek

Use this register to access data read from the EUSART without popping the FIFO.

21.5.18 EUSART_TXDATA - TX Data Register

Offset	Bit Position																															
0x044	31	30	29	28	27	26	25	24	23	22	21	20	19	18	17	16	15	14	13	12	11	10	9	8	7	6	5	4	3	2	1	0
Reset																	0x0															
Access																	W															
Name																	TXDATA															

Bit	Name	Reset	Access	Description
31:16	Reserved	To ensure compatibility with future devices, always write Reserved bits to their reset value, unless otherwise stated. More information in 1.2 Conventions		

15:0	TXDATA	0x0	W	TX Data and Control bits
<p>Use this register to write data to the EUSART. If TXEN is set, a transfer will be initiated at the first opportunity. In Synchronous mode, 15:0 is TXDATA. In Asynchronous mode, if DALICFG.DALIEN is set to 1, then all 16 bits represent data. In Asynchronous mode, if DALICFG.DALIEN is set to 0 then 8:0 is TXDATA, bit 9 is UBRXAT (Set to clear RXBLOCK after transmission, unblocking the receiver), bit 10 is TXTRIAT (Set to tristate transmitter by setting TXTRI after transmission), bit 11 is TXBREAK (Set to send data as a break. Recipient will see a framing error or a break condition depending on its configuration and the value of TXDATA), bit 12 is TXDISAT (Set to disable transmitter and release data bus directly after transmission), bit 13 is RXENAT (Set to enable reception after transmission). Note that FIFO is not retained in EM2</p>				

21.5.19 EUSART_STATUS - Status Register

Offset	Bit Position																																	
0x048	31	30	29	28	27	26	25	24	23	22	21	20	19	18	17	16	15	14	13	12	11	10	9	8	7	6	5	4	3	2	1	0		
Reset							0x0	0x0						0x0					0x1	0x1					0x0	0x0	0x1	0x0	0x0			0x0	0x0	
Access							R	R						R	R				R	R					R	R	R	R	R	R			R	R
Name							CLEARTXBUSY	AUTOBAUDDONE						TXFCNT					TXIDLE	RXIDLE					RXFULL	RXFL	TXFL	TXC	TXTRI	RXBLOCK			TXENS	RXENS

Bit	Name	Reset	Access	Description
31:26	<i>Reserved</i>			<i>To ensure compatibility with future devices, always write Reserved bits to their reset value, unless otherwise stated. More information in 1.2 Conventions</i>
25	CLEARTXBUSY	0x0	R	TX FIFO Clear Busy After issuing CLEAR TX command, wait on this status flag until it goes low.
24	AUTOBAUDDONE	0x0	R	Auto Baud Rate Detection Completed Set when auto baud rate has been detected and CLKDIV has been updated with required value. If AUTOBAUDEN is not set in CFG0 register, this bit is always read as '0'. Only applicable when CFG0.SYNC bit is set to 'ASYNC'.
23:21	<i>Reserved</i>			<i>To ensure compatibility with future devices, always write Reserved bits to their reset value, unless otherwise stated. More information in 1.2 Conventions</i>
20:16	TXFCNT	0x0	R	Valid entries in TX FIFO Count of TX valid FIFO entries.
15:14	<i>Reserved</i>			<i>To ensure compatibility with future devices, always write Reserved bits to their reset value, unless otherwise stated. More information in 1.2 Conventions</i>
13	TXIDLE	0x1	R	TX Idle Set when TX idle. In Synchronous secondary mode, TX is not considered idle when transmitting Default TX data.
12	RXIDLE	0x1	R	RX Idle Set when RX is idle.
11:9	<i>Reserved</i>			<i>To ensure compatibility with future devices, always write Reserved bits to their reset value, unless otherwise stated. More information in 1.2 Conventions</i>
8	RXFULL	0x0	R	RX FIFO Full Set when the RX FIFO is full.
7	RXFL	0x0	R	RX FIFO Level Set when data is available in the RX FIFO. Depends on the RXFIW setting in the CFG1 register.
6	TXFL	0x1	R	TX FIFO Level Set when there is space for data in the TX FIFO. Depends on the TXFIW setting in CFG1 register.
5	TXC	0x0	R	TX Complete Set when a transmission has completed and no more data is available in the TX FIFO and shift register.
4	TXTRI	0x0	R	Transmitter Tristated

Bit	Name	Reset	Access	Description
				Set when the transmitter is tristated, and cleared when transmitter output is enabled. If AUTOTRI in UARTn_CFG is set, then this bit is always read as 0. Only applicable when CFG0.SYNC bit is set to 'ASYNC'.
3	RXBLOCK	0x0	R	Block Incoming Data When set, the receiver discards incoming frames. An incoming frame will not be loaded into the RX FIFO if this bit is set at the instant the frame has been completely received.
2	<i>Reserved</i>	<i>To ensure compatibility with future devices, always write Reserved bits to their reset value, unless otherwise stated. More information in 1.2 Conventions</i>		
1	TXENS	0x0	R	Transmitter Enable Status Set when the transmitter is enabled. In Synchronous secondary mode, default TX data will be transmitted when the transmitter is disabled.
0	RXENS	0x0	R	Receiver Enable Status Set when the receiver is enabled.

21.5.20 EUSART_IF - Interrupt Flag Register

Offset	Bit Position																															
0x04C	31	30	29	28	27	26	25	24	23	22	21	20	19	18	17	16	15	14	13	12	11	10	9	8	7	6	5	4	3	2	1	0
Reset							0x0	0x0					0x0	0x0		0x0			0x0	0x0	0x0	0x0	0x0	0x0	0x0	0x0	0x0	0x0	0x0	0x0	0x0	0x0
Access							RW	RW					RW	RW		RW			RW	RW	RW	RW	RW	RW	RW	RW	RW	RW	RW	RW	RW	
Name							RXTO	AUTOBAUDDONE					SIGF	STARTF		CSWU			TXIDLE	CCF	LOADERR	MPAF	FERR	PERR	TXUF	TXOF	RXUF	RXOF	RXFULL	RXFL	TXFL	TXC

Bit	Name	Reset	Access	Description
31:26	<i>Reserved</i>			<i>To ensure compatibility with future devices, always write Reserved bits to their reset value, unless otherwise stated. More information in 1.2 Conventions</i>
25	RXTO	0x0	RW	RX Timeout Interrupt Flag Set when RX timeout occurs. Only applicable when CFG0.SYNC bit is set to 'ASYN'.
24	AUTOBAUDDONE	0x0	RW	Auto Baud Complete Interrupt Flag Set when auto baud rate detection is complete. Only applicable when CFG0.SYNC bit is set to 'ASYN'.
23:20	<i>Reserved</i>			<i>To ensure compatibility with future devices, always write Reserved bits to their reset value, unless otherwise stated. More information in 1.2 Conventions</i>
19	SIGF	0x0	RW	Signal Frame Interrupt Flag Set when a signal frame is detected. Please note that when MPA, START, and SIGNAL are set to match the same frame, corresponding interrupts might get triggered in arbitrary sequence due to synchronization uncertainty. Only applicable when CFG0.SYNC bit is set to 'ASYN'.
18	STARTF	0x0	RW	Start Frame Interrupt Flag Set when a start frame is detected. Please note that when MPA, START, and SIGNAL are set to match the same frame, corresponding interrupts might get triggered in arbitrary sequence due to synchronization uncertainty. Only applicable when CFG0.SYNC bit is set to 'ASYN'.
17	<i>Reserved</i>			<i>To ensure compatibility with future devices, always write Reserved bits to their reset value, unless otherwise stated. More information in 1.2 Conventions</i>
16	CSWU	0x0	RW	CS Wake-up Interrupt Flag Set when the CS asserts. Only applicable when CFG0.SYNC bit is set to 'SYNC' and CFG2.MASTER is set to 'SLAVE'.
15:14	<i>Reserved</i>			<i>To ensure compatibility with future devices, always write Reserved bits to their reset value, unless otherwise stated. More information in 1.2 Conventions</i>
13	TXIDLE	0x0	RW	TX Idle Interrupt Flag Set when TX goes idle. In Synchronous mode, if TX is disabled during the middle of the transactions, TXIDLEIF won't be triggered when the engine becomes disabled.
12	CCF	0x0	RW	Collision Check Fail Interrupt Flag Set when a collision check notices an error in the transmitted data. Only applicable when CFG0.SYNC bit is set to 'ASYN'.
11	LOADERR	0x0	RW	Load Error Interrupt Flag

Bit	Name	Reset	Access	Description
				Set when the empty TX FIFO is loaded less than the required TIMINGCFG.SETUPWINDOW bus clock cycles before the first edge of the incoming SCLK. Only applicable when CFG0.SYNC bit is set to 'SYNC' and CFG2.MASTER is set to 'SLAVE' and CFG2.FORCELOAD is set.
10	MPAF	0x0	RW	Multi-Processor Address Frame Interrupt Set when a multi-processor address frame is detected. Only applicable when CFG0.SYNC bit is set to 'ASYNC'.
9	FERR	0x0	RW	Framing Error Interrupt Flag Set when a frame with a framing error is received while RXBLOCK is cleared. Only applicable when CFG0.SYNC bit is set to 'ASYNC'.
8	PERR	0x0	RW	Parity Error Interrupt Flag Set when a frame with a parity error is received while RXBLOCK is cleared. Only applicable when CFG0.SYNC bit is set to 'ASYNC'.
7	TXUF	0x0	RW	TX FIFO Underflow Interrupt Flag In Sync secondary mode, Set when reading an empty TX FIFO with TX enabled. In Synchronous main Mode with AUTOTX enabled, set when transmitting the word that does not contain valid data.
6	TXOF	0x0	RW	TX FIFO Overflow Interrupt Flag Set when a write is done to the TX FIFO while it is full. The data already in the TX FIFO is preserved.
5	RXUF	0x0	RW	RX FIFO Underflow Interrupt Flag Set when trying to read from the RX FIFO when it is empty.
4	RXOF	0x0	RW	RX FIFO Overflow Interrupt Flag Set when data is completely received in the receive shift register but the RX FIFO is full. RX FIFO is not overwritten by new data.
3	RXFULL	0x0	RW	RX FIFO Full Interrupt Flag Set when the RX FIFO becomes full.
2	RXFL	0x0	RW	RX FIFO Level Interrupt Flag Set when data becomes available in the RX FIFO. This field depends on the RXFIW field in the CFG1 register.
1	TXFL	0x0	RW	TX FIFO Level Interrupt Flag Set when space becomes available in the TX FIFO. This depends on the TXFIW field in the CFG1 register.
0	TXC	0x0	RW	TX Complete Interrupt Flag This interrupt is set after a transmission when both the TX FIFO and shift register are empty.

21.5.21 EUSART_IEN - Interrupt Enable Register

Offset	Bit Position																															
0x050	31	30	29	28	27	26	25	24	23	22	21	20	19	18	17	16	15	14	13	12	11	10	9	8	7	6	5	4	3	2	1	0
Reset							0x0	0x0					0x0	0x0		0x0			0x0	0x0	0x0	0x0	0x0	0x0	0x0	0x0	0x0	0x0	0x0	0x0	0x0	0x0
Access							RW	RW					RW	RW		RW			RW	RW	RW	RW	RW	RW	RW	RW	RW	RW	RW	RW	RW	RW
Name							RXTO	AUTOBAUDDONE					SIGF	STARTF		CSWU			TXIDLE	CCF	LOADERR	MPAF	FERR	PERR	TXUF	TXOF	RXUF	RXOF	RXFULL	RXFL	TXFL	TXC

Bit	Name	Reset	Access	Description
31:26	<i>Reserved</i>			<i>To ensure compatibility with future devices, always write Reserved bits to their reset value, unless otherwise stated. More information in 1.2 Conventions</i>
25	RXTO	0x0	RW	RX Timeout Enable Interrupt enable for RXTOIF.
24	AUTOBAUDDONE	0x0	RW	Auto Baud Complete Enable Interrupt enable for AUTOBAUDDONEIF.
23:20	<i>Reserved</i>			<i>To ensure compatibility with future devices, always write Reserved bits to their reset value, unless otherwise stated. More information in 1.2 Conventions</i>
19	SIGF	0x0	RW	Signal Frame Enable Interrupt enable for SIGFIF.
18	STARTF	0x0	RW	Start Frame Enable Interrupt enable for STARTFIF.
17	<i>Reserved</i>			<i>To ensure compatibility with future devices, always write Reserved bits to their reset value, unless otherwise stated. More information in 1.2 Conventions</i>
16	CSWU	0x0	RW	CS Wake-up Enable Interrupt enable for CSWUIF.
15:14	<i>Reserved</i>			<i>To ensure compatibility with future devices, always write Reserved bits to their reset value, unless otherwise stated. More information in 1.2 Conventions</i>
13	TXIDLE	0x0	RW	TX IDLE Enable Interrupt enable for TXIDLEIF.
12	CCF	0x0	RW	Collision Check Fail Enable Interrupt enable for CCFIF.
11	LOADERR	0x0	RW	Load Error Enable Interrupt enable for LOADERRIF.
10	MPAF	0x0	RW	Multi-Processor Addr Frame Enable Interrupt enable for MPAFIF.
9	FERR	0x0	RW	Framing Error Enable Interrupt enable for FERRIF.

Bit	Name	Reset	Access	Description
8	PERR	0x0	RW	Parity Error Enable Interrupt enable for PERRIF.
7	TXUF	0x0	RW	TX FIFO Underflow Enable Interrupt enable for TXUFIF.
6	TXOF	0x0	RW	TX FIFO Overflow Enable Interrupt enable for TXOFIF.
5	RXUF	0x0	RW	RX FIFO Underflow Enable Interrupt enable for RXUFIF.
4	RXOF	0x0	RW	RX FIFO Overflow Enable Interrupt enable for RXOFIF.
3	RXFULL	0x0	RW	RX FIFO Full Enable Interrupt enable for RXFULLIF.
2	RXFL	0x0	RW	RX FIFO Level Enable Interrupt enable for RXFLIF.
1	TXFL	0x0	RW	TX FIFO Level Enable Interrupt enable for TXFLIF.
0	TXC	0x0	RW	TX Complete Enable Interrupt enable for TXCIF.

21.5.22 EUSART_SYNCBUSY - Synchronization Busy Register

Offset	Bit Position																																																				
0x054	31	30	29	28	27	26	25	24	23	22	21	20	19	18	17	16	15	14	13	12	11	10	9	8	7	6	5	4	3	2	1	0																					
Reset																					0x0	0x0	0x0	0x0	0x0	0x0	0x0	0x0	0x0	0x0	0x0	0x0	0x0	0x0	0x0	0x0	0x0	0x0	0x0	0x0	0x0	0x0	0x0	0x0	0x0	0x0	0x0	0x0	0x0	0x0	0x0	0x0	
Access																					R	R	R	R	R	R	R	R	R	R	R	R	R	R	R	R	R	R	R	R	R	R	R	R	R	R	R	R	R	R	R	R	R
Name																					AUTOTXTEN	TXTRIDIS	TXTRIEN	RXBLOCKDIS	RXBLOCKEN	TXDIS	TXEN	RXDIS	RXEN	TXTEN	RXTEN	DIV																					

Bit	Name	Reset	Access	Description
31:12	<i>Reserved</i>	<i>To ensure compatibility with future devices, always write Reserved bits to their reset value, unless otherwise stated. More information in 1.2 Conventions</i>		
11	AUTOTXTEN	0x0	R	SYNCBUSY for AUTOTXTEN in TRIGCTRL This bit is set when there is an ongoing synchronization of AUTOTXTEN field. Do not do another write to the same field while this bit is set.
10	TXTRIDIS	0x0	R	SYNCBUSY in TXTRIDIS in CMD This bit is set when there is an ongoing synchronization of TXTRIDIS field. Do not do another write to the same field while this bit is set. Only applicable when CFG0.SYNC bit is set to 'ASYN'.
9	TXTRIEN	0x0	R	SYNCBUSY for TXTRIEN in CMD This bit is set when there is an ongoing synchronization of TXTRIEN field. Do not do another write to the same field while this bit is set.
8	RXBLOCKDIS	0x0	R	SYNCBUSY for RBLOCKDIS in CMD This bit is set when there is an ongoing synchronization of RBLOCKDIS field. Do not do another write to the same field while this bit is set.
7	RXBLOCKEN	0x0	R	SYNCBUSY for RBLOCKEN in CMD This bit is set when there is an ongoing synchronization of RBLOCKEN field. Do not do another write to the same field while this bit is set.
6	TXDIS	0x0	R	SYNCBUSY for TXDIS in CMD This bit is set when there is an ongoing synchronization of TXDIS field. Do not do another write to the same field while this bit is set.
5	TXEN	0x0	R	SYNCBUSY for TXEN in CMD This bit is set when there is an ongoing synchronization of TXEN field. Do not do another write to the same field while this bit is set.
4	RXDIS	0x0	R	SYNCBUSY for RXDIS in CMD This bit is set when there is an ongoing synchronization of RXDIS field. Do not do another write to the same field while this bit is set.
3	RXEN	0x0	R	SYNCBUSY for RXEN in CMD This bit is set when there is an ongoing synchronization of RXEN field. Do not do another write to the same field while this bit is set.
2	TXTEN	0x0	R	SYNCBUSY for TXTEN in TRIGCTRL This bit is set when there is an ongoing synchronization of TXTEN field. Do not do another write to the same field while this bit is set.

Bit	Name	Reset	Access	Description
1	RXTEN	0x0	R	SYNCBUSY for RXTEN in TRIGCTRL This bit is set when there is an ongoing synchronization of RXTEN field. Do not do another write to the same field while this bit is set.
0	DIV	0x0	R	SYNCBUSY for DIV in CLKDIV This bit is set when there is an ongoing synchronization of DIV field. Do not do another write to the same field while this bit is set.

21.5.23 EUSART_DALICFG - DALI Config Register

Offset	Bit Position																																			
0x058	31	30	29	28	27	26	25	24	23	22	21	20	19	18	17	16	15	14	13	12	11	10	9	8	7	6	5	4	3	2	1	0				
Reset																	0x0							0x0							0x0	0x0				
Access																	RW							RW							RW	RW				
Name																	DALIRXENDT							DALIRXDATABITS						DALITXDATABITS						DALIEN

Bit	Name	Reset	Access	Description
31:16	<i>Reserved</i>	<i>To ensure compatibility with future devices, always write Reserved bits to their reset value, unless otherwise stated. More information in 1.2 Conventions</i>		
15	DALIRXENDT	0x0	RW	DALI RX Enabled During Transmission If set, then EUSART RX will stay enabled during EUSART DALI TX. Should be set in loopback mode.
14:13	<i>Reserved</i>	<i>To ensure compatibility with future devices, always write Reserved bits to their reset value, unless otherwise stated. More information in 1.2 Conventions</i>		
12:8	DALIRXDATABITS	0x0	RW	DALI RX Databits DALI RX databits (8-32). Only used if DALIEN is set.
	Value	Mode		Description
	0	EIGHT		Each frame contains 8 data bits
	1	NINE		Each frame contains 9 data bits
	2	TEN		Each frame contains 10 data bits
	3	ELEVEN		Each frame contains 11 data bits
	4	TWELVE		Each frame contains 12 data bits
	5	THIRTEEN		Each frame contains 13 data bits
	6	FOURTEEN		Each frame contains 14 data bits
	7	FIFTEEN		Each frame contains 15 data bits
	8	SIXTEEN		Each frame contains 16 data bits
	9	SEVENTEEN		Each frame contains 17 data bits
	10	EIGHTEEN		Each frame contains 18 data bits
	11	NINETEEN		Each frame contains 19 data bits
	12	TWENTY		Each frame contains 20 data bits
	13	TWENTYONE		Each frame contains 21 data bits
	14	TWENTYTWO		Each frame contains 22 data bits
	15	TWENTYTHREE		Each frame contains 23 data bits
	16	TWENTYFOUR		Each frame contains 24 data bits
	17	TWENTYFIVE		Each frame contains 25 data bits

Bit	Name	Reset	Access	Description
	18	TWENTYSIX		Each frame contains 26 data bits
	19	TWENTYSEVEN		Each frame contains 27 data bits
	20	TWENTYEIGHT		Each frame contains 28 data bits
	21	TWENTYNINE		Each frame contains 29 data bits
	22	THIRTY		Each frame contains 30 data bits
	23	THIRTYONE		Each frame contains 31 data bits
	24	THIRTYTWO		Each frame contains 32 data bits
7:6	<i>Reserved</i>	<i>To ensure compatibility with future devices, always write Reserved bits to their reset value, unless otherwise stated. More information in 1.2 Conventions</i>		
5:1	DALITXDATABITS	0x0	RW	DALI TX Databits
	DALI TX databits (8-32). Only used if DALIEN is set.			
	Value	Mode		Description
	0	EIGHT		Each frame contains 8 data bits
	1	NINE		Each frame contains 9 data bits
	2	TEN		Each frame contains 10 data bits
	3	ELEVEN		Each frame contains 11 data bits
	4	TWELVE		Each frame contains 12 data bits
	5	THIRTEEN		Each frame contains 13 data bits
	6	FOURTEEN		Each frame contains 14 data bits
	7	FIFTEEN		Each frame contains 15 data bits
	8	SIXTEEN		Each frame contains 16 data bits
	9	SEVENTEEN		Each frame contains 17 data bits
	10	EIGHTEEN		Each frame contains 18 data bits
	11	NINETEEN		Each frame contains 19 data bits
	12	TWENTY		Each frame contains 20 data bits
	13	TWENTYONE		Each frame contains 21 data bits
	14	TWENTYTWO		Each frame contains 22 data bits
	15	TWENTYTHREE		Each frame contains 23 data bits
	16	TWENTYFOUR		Each frame contains 24 data bits
	17	TWENTYFIVE		Each frame contains 25 data bits
	18	TWENTYSIX		Each frame contains 26 data bits
	19	TWENTYSEVEN		Each frame contains 27 data bits
	20	TWENTYEIGHT		Each frame contains 28 data bits
	21	TWENTYNINE		Each frame contains 29 data bits
	22	THIRTY		Each frame contains 30 data bits
	23	THIRTYONE		Each frame contains 31 data bits
	24	THIRTYTWO		Each frame contains 32 data bits

Bit	Name	Reset	Access	Description
0	DALIEN	0x0	RW	DALI Enable Bit DALI EN bit.



22. I²C - Inter-Integrated Circuit Interface

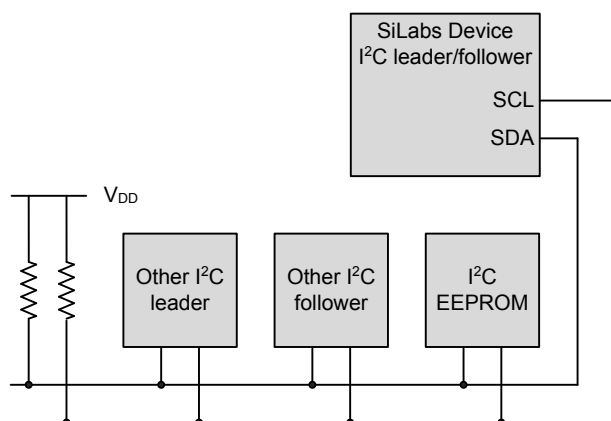
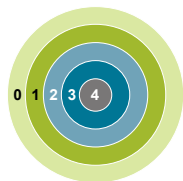

Quick Facts

What?

The I²C interface allows communication on I²C-buses with the lowest energy consumption possible.

Why?

I²C is a popular serial bus that enables communication with a number of external devices using only two I/O pins.

How?

With the help of DMA, the I²C interface allows I²C communication with minimal CPU intervention. Address recognition is available in all energy modes (except EM4), allowing the MCU to wait for data on the I²C-bus with sub- μ A current consumption.

22.1 Introduction

The I²C module provides an interface between the MCU and a serial I²C-bus. It is capable of acting as both a leader and a follower and supports multi-leader buses. Standard-mode, fast-mode and fast-mode plus speeds are supported, allowing transmission rates all the way from 10 kbit/s up to 1 Mbit/s. Follower arbitration and timeouts are also provided to allow implementation of an SMBus compliant system. The interface provided to software by the I²C module allows precise control of the transmission process and highly automated transfers. Automatic recognition of follower addresses is provided in all energy modes (except EM4).

22.2 Features

- True multi-leader capability
- Support for different bus speeds
 - Standard-mode (Sm) bit rate up to 100 kbit/s
 - Fast-mode (Fm) bit rate up to 400 kbit/s
 - Fast-mode Plus (Fm+) bit rate up to 1 Mbit/s
- Arbitration for both leader and follower (allows SMBus ARP)
- Clock synchronization and clock stretching
- Hardware address recognition
 - 7-bit masked address
 - General call address
 - Supported in EM2/3 (I2C0-only)
- 10-bit address support
- Error handling
 - Clock low timeout
 - Bus idle (clock high) timeout
 - Arbitration lost
 - Bus error detection
- Separate receive/ transmit 2-level buffers, with additional separate shift registers
- Full DMA support

22.3 Functional Description

An overview of the I2C module is shown in [Figure 22.1 I2C Overview on page 701](#).

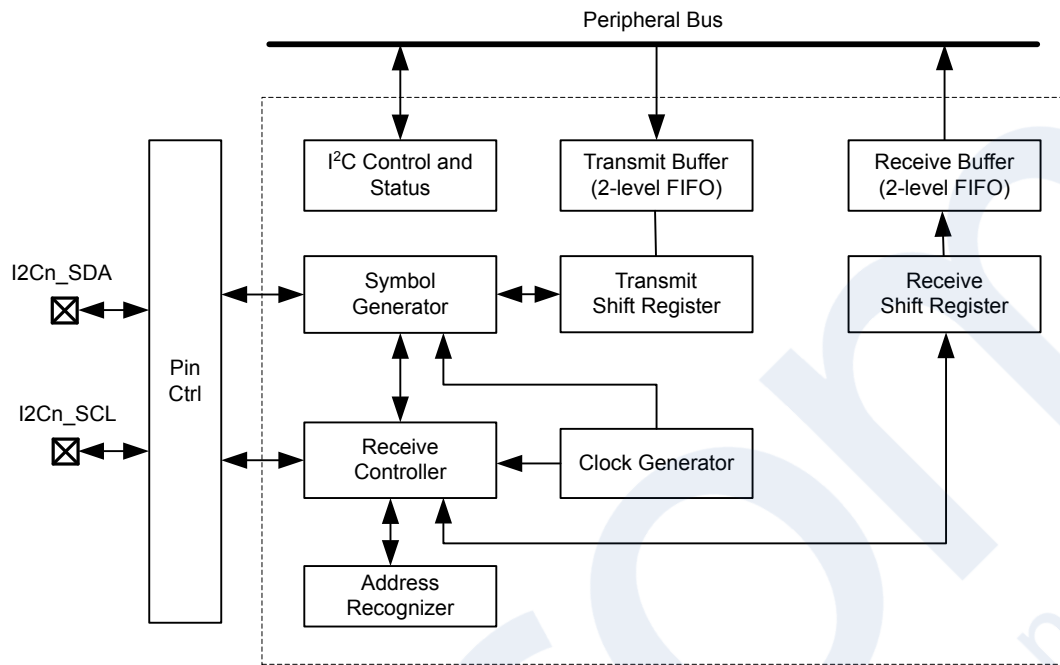

Figure 22.1. I2C Overview

22.3.1 I2C-Bus Overview

The I²C-bus uses two wires for communication; a serial data line (SDA) and a serial clock line (SCL) as shown in [Figure 22.2 I2C-Bus Example on page 702](#). As a true multi-leader bus it includes collision detection and arbitration to resolve situations where multiple leaders transmit data at the same time without data loss.

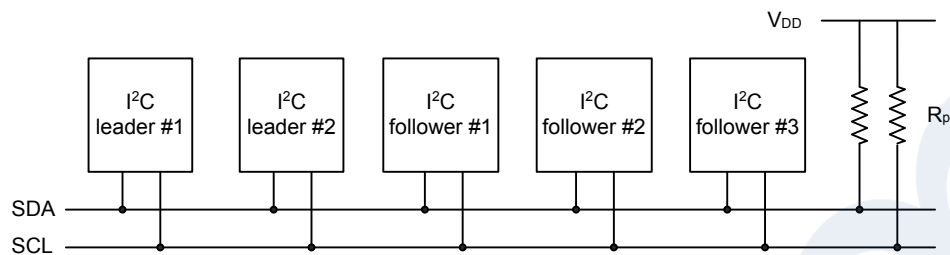

Figure 22.2. I2C-Bus Example

Each device on the bus is addressable by a unique address, and an I²C leader can address all the devices on the bus, including other leaders.

Both the bus lines are open-drain. The maximum value of the pull-up resistor can be calculated as a function of the maximal rise-time t_r for the given bus speed, and the estimated bus capacitance C_b as shown in [Figure 22.3 I2C Pull-up Resistor Equation on page 702](#).

$$R_{p(\max)} = t_r / (0.8473 \times C_b).$$

Figure 22.3. I2C Pull-up Resistor Equation

The maximal rise times for 100 kHz, 400 kHz and 1 MHz I²C are 1 μ s, 300 ns and 120 ns respectively.

Note: The GPIO slew rate control should be set for the desired slew rate..

Note: If V_{dd} drops below the voltage on SCL and SDA lines, the MCU could become back powered and pull the SCL and SDA lines low.

22.3.1.1 START and STOP Conditions

START and STOP conditions are used to initiate and stop transactions on the I²C-bus. All transactions on the bus begin with a START condition (S) and end with a STOP condition (P). As shown in [Figure 22.4 I²C START and STOP Conditions on page 703](#), a START condition is generated by pulling the SDA line low while SCL is high, and a STOP condition is generated by pulling the SDA line high while SCL is high.

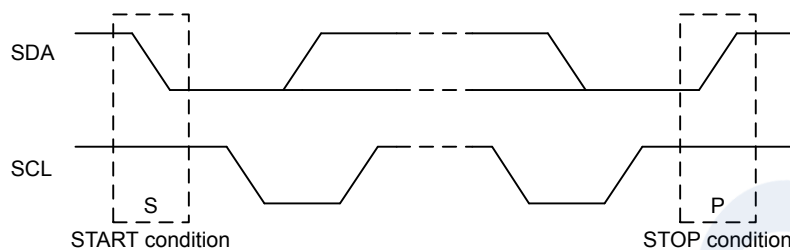

Figure 22.4. I²C START and STOP Conditions

The START and STOP conditions are easily identifiable bus events as they are the only conditions on the bus where a transition is allowed on SDA while SCL is high. During the actual data transmission, SDA is only allowed to change while SCL is low, and must be stable while SCL is high. One bit is transferred per clock pulse on the I²C-bus as shown in [Figure 22.5 I²C Bit Transfer on I²C-Bus on page 703](#).

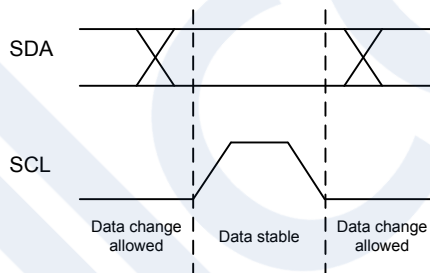

Figure 22.5. I²C Bit Transfer on I²C-Bus

22.3.1.2 Bus Transfer

When a leader wants to initiate a transfer on the bus, it waits until the bus is idle and transmits a START condition on the bus. The leader then transmits the address of the follower it wishes to interact with and a single R/W bit telling whether it wishes to read from the follower (R/W bit set to 1) or write to the follower (R/W bit set to 0).

After the 7-bit address and the R/W bit, the leader releases the bus, allowing the follower to acknowledge the request. During the next bit-period, the follower pulls SDA low (ACK) if it acknowledges the request, or keeps it high if it does not acknowledge it (NACK).

Following the address acknowledge, either the follower or leader transmits data, depending on the value of the R/W bit. After every 8 bits (one byte) transmitted on the SDA line, the transmitter releases the line to allow the receiver to transmit an ACK or a NACK. Both the data and the address are transmitted with the most significant bit first.

The number of bytes in a bus transfer is unrestricted. The leader ends the transmission after a (N)ACK by sending a STOP condition on the bus. After a STOP condition, any leader wishing to initiate a transfer on the bus can try to gain control of it. If the current leader wishes to make another transfer immediately after the current, it can start a new transfer directly by transmitting a repeated START condition (Sr) instead of a STOP followed by a START.

Examples of I²C transfers are shown in [Figure 22.6 I2C Single Byte Write to Follower on page 704](#), [Figure 22.7 I2C Double Byte Read from Follower on page 704](#), and [Figure 22.8 I2C Single Byte Write, then Repeated Start and Single Byte Read on page 704](#). The identifiers used are:

- ADDR - Address
- DATA - Data
- S - Start bit
- Sr - Repeated start bit
- P - Stop bit
- W/R - Read(1)/Write(0)
- A - ACK
- N - NACK



Figure 22.6. I2C Single Byte Write to Follower



Figure 22.7. I2C Double Byte Read from Follower

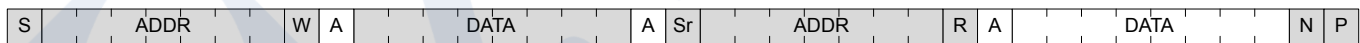

Figure 22.8. I2C Single Byte Write, then Repeated Start and Single Byte Read

22.3.1.3 Addresses

I²C supports both 7-bit and 10-bit addresses. When using 7-bit addresses, the first byte transmitted after the START-condition contains the address of the follower that the leader wants to contact. In the 7-bit address space, several addresses are reserved. These addresses are summarized in [Table 22.1 I2C Reserved I2C Addresses on page 705](#), and include a General Call address which can be used to broadcast a message to all followers on the I²C-bus.

Table 22.1. I2C Reserved I2C Addresses

I ² C Address	R/W	Description
0000-000	0	General Call address
0000-000	1	START byte
0000-001	X	Reserved for the C-Bus format
0000-010	X	Reserved for a different bus format
0000-011	X	Reserved for future purposes
0000-1XX	X	Reserved for future purposes
1111-1XX	X	Reserved for future purposes
1111-0XX	X	10 Bit follower addressing mode

22.3.1.4 10-bit Addressing

To address a follower using a 10-bit address, two bytes are required to specify the address instead of one. The seven first bits of the first byte must then be 1111 0XX, where XX are the two most significant bits of the 10-bit address. As with 7-bit addresses, the eighth bit of the first byte determines whether the leader wishes to read from or write to the follower. The second byte contains the eight least significant bits of the follower address.

When a follower receives a 10-bit address, it must acknowledge both the address bytes if they match the address of the follower.

When performing a leader transmitter operation, the leader transmits the two address bytes and then the remaining data, as shown in [Figure 22.9 I2C Leader Transmitter/Follower Receiver with 10-bit Address on page 705](#).

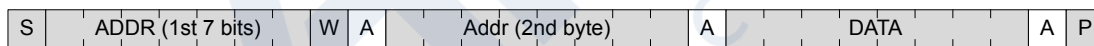

Figure 22.9. I2C Leader Transmitter/Follower Receiver with 10-bit Address

When performing a leader receiver operation however, the leader first transmits the two address bytes in a leader transmitter operation, then sends a repeated START followed by the first address byte and then receives data from the addressed follower. The follower addressed by the 10-bit address in the first two address bytes must remember that it was addressed, and respond with data if the address transmitted after the repeated start matches its own address. An example of this (with one byte transmitted) is shown in [Figure 22.10 I2C Leader Receiver/Follower Transmitter with 10-bit Address on page 705](#).

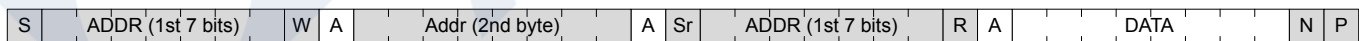

Figure 22.10. I2C Leader Receiver/Follower Transmitter with 10-bit Address

22.3.1.5 Arbitration, Clock Synchronization, Clock Stretching

Arbitration and clock synchronization are features aimed at allowing multi-leader buses. Arbitration occurs when two devices try to drive the bus at the same time. If one device drives it low, while the other drives it high, the one attempting to drive it high will not be able to do so due to the open-drain bus configuration. Both devices sample the bus, and the one that was unable to drive the bus in the desired direction detects the collision and backs off, letting the other device continue communication on the bus undisturbed.

Clock synchronization is a means of synchronizing the clock outputs from several leaders driving the bus at once, and is a requirement for effective arbitration.

Followers on the bus are allowed to force the clock output on the bus low in order to pause the communication on the bus and give themselves time to process data or perform any real-time tasks they might have. This is called clock stretching.

Arbitration is supported by the I²C module for both leaders and followers. Clock synchronization and clock stretching is also supported.

22.3.2 Enable and Reset

The I²C is enabled by setting the EN bit in the I2C_EN register.

To reset the internal state of the I²C module and terminate any ongoing transfers, set the CORERST bit in I2C_CTRL. After resetting, the CORERST bit must be cleared to resume I²C operation.

Note: When enabling the I²C, the ABORT command or the Bus Idle Timeout feature must be applied prior to use even if the BUSY flag is not set.

22.3.3 Pin Configuration

The I²C SDA and SCL pins are configured and enabled in the GPIO_I2Cn_ROUTEEN, GPIO_I2Cn_SCLROUTE, and GPIO_I2Cn_SDARROUTE registers.

The I²C module must be configured to use pins on either Port A or B if wakeup on address recognition from EM2/3 is desired. All other ports are available only in EM0/1. See GPIO chapter for more details on Port limitations.

If the I²C module is configured to use pins other than Port A or B, firmware should reset the module before entering EM2/3 by setting the CORERST bit in I2C_CTRL. After resuming EM0/1 operation, firmware should then clear CORERST.

22.3.4 Safely Disabling and Changing Follower Configuration

The I²C follower is partially asynchronous, and some precautions are necessary to always ensure a safe follower disable or follower configuration change. These measures should be taken, if (while the follower is enabled) the user cannot guarantee that an address match will not occur at the exact time of follower disable or follower configuration change.

Worst case consequences for an address match while disabling follower or changing configuration is that the follower may end up in an undefined state. To reset the follower back to a known state, the EN bit in I2C_EN must be cleared. This should be done regardless of whether the follower is going to be re-enabled or not.

22.3.5 Clock Generation

The I²C peripheral clock (I2CCLK) for I2C0 is derived from the LSPCLK, and for I2C1 is derived from the PCLK.

The SCL signal generated by the I²C leader determines the maximum transmission rate on the bus. The clock is generated as a division of the peripheral clock (I2CCLK), and is given by the following equation:

$$f_{SCL} = f_{I2CCLK} / (((N_{low} + N_{high}) \times (DIV + 1)) + 8 + N_{fall} + N_{rise})$$

Figure 22.11. I2C Maximum Transmission Rate

Where DIV is the clock divider value set in I2C_CLKDIV, the values of N_{low} and N_{high} (and thus the ratio between the high and low parts of the clock signal) are controlled by CLHR in the I2C_CTRL register, and N_{fall} and N_{rise} represent the number of I2CCLK cycles required for clock synchronization.

The values of N_{low} and N_{high} specify the number of prescaled clock cycles in the low and high periods of the clock signal respectively. The worst case low and high periods of the signal are:

$$t_{high} \geq (N_{high} \times (DIV + 1) + 4) / f_{I2CCLK}$$

$$t_{low} \geq (N_{low} \times (DIV + 1) + 4) / f_{I2CCLK}$$

Figure 22.12. I2C High and Low Cycles Equations

Clock synchronization is used to ensure that requested low and high times are met on the bus. The counters establishing high and low time are only active once the pin logic has reached the high or low logic levels, and so the rise and fall times will impact the maximum transmission rate on the bus. The clock logic level is sampled at a rate of f_{I2CCLK} , and will therefore be quantized to an integer number of I2CCLK clock cycles, as:

$$N_{rise} = \text{CEILING}(t_{rise} / t_{I2CCLK})$$

$$N_{fall} = \text{CEILING}(t_{fall} / t_{I2CCLK})$$

Figure 22.13. I2C Clock Synchronization Cycles

Note that there is an inherent propagation delay between driving SCL and sampling the signal, so the above equations can result in $N = 0$ for fast rise or fall times.

For example, a system with a weak pull-up on SCL may result in long t_{rise} , requiring several N_{rise} synchronization cycles, and subsequently impact the I2C transmission rate. In the same system, t_{fall} may be faster than the sampling delay, resulting in $N_{fall} = 0$.

Note: DIV must be set to 1 during follower mode operation.

22.3.6 Arbitration

Arbitration is enabled by default, but can be disabled by setting the ARBDIS bit in I2C_CTRL. When arbitration is enabled, the value on SDA is sensed every time the I²C module attempts to change its value. If the sensed value is different than the value the I²C module tried to output, it is interpreted as a simultaneous transmission by another device, and that the I²C module has lost arbitration.

Whenever arbitration is lost, the ARBLOST interrupt flag in I2C_IF is set, any lines held are released, and the I²C device goes idle. If an I²C leader loses arbitration during the transmission of an address, another leader may be trying to address it. The leader therefore receives the rest of the address, and if the address matches the follower address of the leader, the leader goes into either follower transmitter or follower receiver mode.

Note:

Arbitration can be lost both when operating as a leader and when operating as a follower.

22.3.7 Buffers

22.3.7.1 Transmit Buffer and Shift Register

The I²C transmitter has a 2-level FIFO transmit buffer and a transmit shift register as shown in [Figure 22.1 I2C Overview on page 701](#). A byte is loaded into the transmit buffer by writing to I2C_TXDATA or 2 bytes can be loaded simultaneously in the transmit buffer by writing to I2C_TXDOUBLE. [Figure 22.14 I2C Transmit Buffer Operation on page 708](#) shows the basics of the transmit buffer. When the transmit shift register is empty and ready for new data, the byte from the transmit buffer is then loaded into the shift register. The byte is then kept in the shift register until it is transmitted. When a byte has been transmitted, a new byte is loaded into the shift register (if available in the transmit buffer). If the transmit buffer is empty, then the shift register also remains empty. The TXC flag in I2C_STATUS and the TXC interrupt flags in I2C_IF are then set, signaling that the transmit shift register is out of data. TXC is cleared when new data becomes available, but the TXC interrupt flag must be cleared by software.

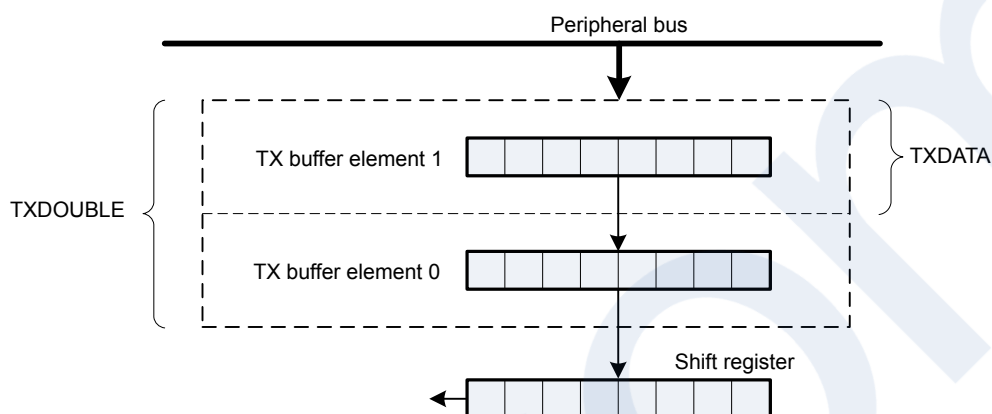

Figure 22.14. I2C Transmit Buffer Operation

The TXBL flags in I2C_STATUS and I2C_IF are used to indicate the level of the transmit buffer. The TXBIL bit in I2C_CTRL controls the level at which these flag bits are set:

- If TXBIL is cleared, the TXBL flags are set whenever the transmit buffer becomes empty (used when transmitting using I2C_TXDOUBLE).
- If TXBIL is set, the TXBL flags are set whenever the transmit buffer goes from full to half-empty or empty (used when transmitting with I2C_TXDATA).

The TXBL status flag in I2C_STATUS is cleared automatically when the condition becomes false. After the transmit FIFOs are filled, software needs to manually clear the TXBL interrupt flag. Note that the TXBL interrupt flag is 0 by default, but immediately after software sets I2C_EN.EN = 1, the TXBL interrupt flag will be set to indicate the transmit FIFO is empty. When the I²C module is disabled (I2C_EN.EN= 0), software needs to manually clear the TXBL interrupt flag (or ignore it).

Additionally, the TXBUFCNT bitfield in I2C_STATUS can be read to determine the exact number of transmit buffers filled with valid data. This is particularly useful for determining whether the transmit buffers are full. For example, if TXBUFCNT = '2', firmware can determine that both transmit buffers are filled, and that any additional data written to the transmit buffer would result in an overflow condition. Note that the TXBUFCNT count does not include the TX shift register.

If an attempt is made to write more bytes to the transmit buffer than the space available, the TXOF interrupt flag in I2C_IF is set, indicating the overflow. The data already in the buffer remains preserved, and no new data is written.

The transmit buffer and the transmit shift register can be cleared by setting command bit CLEAR_TX in I2C_CMD. This will prevent the I²C module from transmitting the data in the buffer and the shift register, and will make them available for new data. Any byte currently being transmitted will not be aborted. Transmission of this byte will be completed.

22.3.7.2 Receive Buffer and Shift Register

The I²C receiver uses a 2-level FIFO receive buffer and a receive shift register as shown in [Figure 22.15 I2C Receive Buffer Operation on page 709](#). When a byte has been fully received by the receive shift register, it is loaded into the receive buffer if there is room for it, making the shift register empty to receive another byte. Otherwise, the byte waits in the shift register until space becomes available in the buffer.

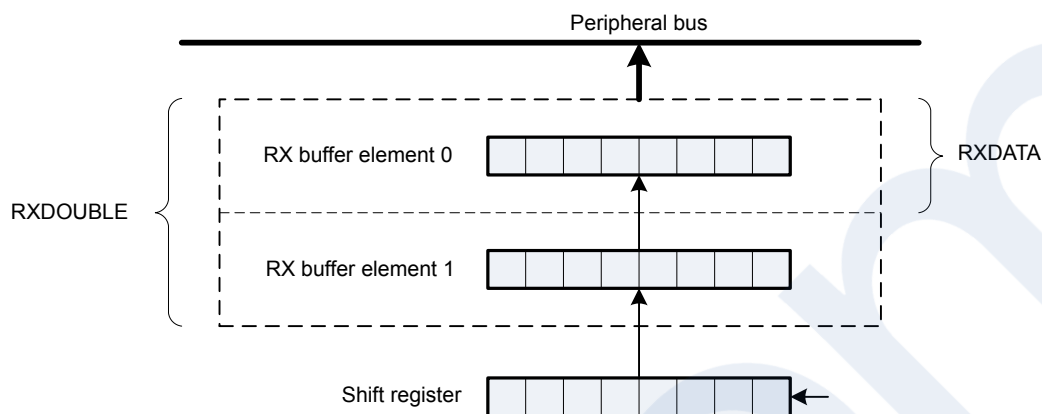

Figure 22.15. I2C Receive Buffer Operation

When a byte becomes available in the receive buffer, the RXDATAV flags in I2C_STATUS and I2C_IF are set. When the buffer becomes full, the RXFULL flags in I2C_STATUS and I2C_IF are set. The RXDATAV and RXFULL flags in I2C_STATUS are automatically cleared by hardware when their condition is no longer true. The RXDATAV and RXFULL flags in I2C_IF must be manually cleared by software after the receive FIFO is emptied. Note that when the RXFULL flag is set, indicating the buffer is full, space is still available in the receive shift register for one more byte.

The data can be fetched from the buffer in two ways. I2C_RXDATA gives access to the received byte (if two bytes are received then the one received first is fetched first). I2C_RXDOUBLE makes it possible to read the two received bytes simultaneously. If an attempt is made to read more bytes from the buffer than available, the RXUF interrupt flag in I2C_IF is set to signal the underflow, and the data read from the buffer is undefined.

When using I2C_RXDOUBLE to pick data, AUTOACK in I2C_CTRL should be set to 1. This ensures that an ACK is automatically sent out after the first byte is received so that the reception of the next byte can begin. In order to stop receiving data bytes, a NACK must be sent out through the I2C_CMD register.

I2C_RXDATAP and I2C_RXDOUBLEP can be used to read data from the receive buffer without removing it from the buffer. The RXUF interrupt flag in I2C_IF will never be set as a result of reading from I2C_RXDATAP and I2C_RXDOUBLEP, but the data read through I2C_RXDATAP when the receive buffer is empty is still undefined.

Once a transaction is complete (STOP sent or received), the receive buffer needs to be flushed (all received data must be read) before starting a new transaction.

22.3.8 Leader Operation

A bus transaction is initiated by transmitting a START condition (S) on the bus. This is done by setting the START bit in I2C_CMD. The command schedules a START condition, and makes the I²C module generate a start condition whenever the bus becomes free.

The I²C-bus is considered busy whenever another device on the bus transmits a START condition. Until a STOP condition is detected, the bus is owned by the leader issuing the START condition. The bus is considered free when a STOP condition is transmitted on the bus. After a STOP is detected, all leaders that have data to transmit send a START condition and begin transmitting data. Arbitration ensures that collisions are avoided.

When the START condition has been transmitted, the leader must transmit a follower address (ADDR) with an R/W bit on the bus. If this address is available in the transmit buffer, the leader transmits it immediately, but if the buffer is empty, the leader holds the I²C-bus while waiting for software to write the address to the transmit buffer.

After the address has been transmitted, a sequence of bytes can be read from or written to the follower, depending on the value of the R/W bit (bit 0 in the address byte). If the bit was cleared, the leader has entered a leader transmitter role, where it now transmits data to the follower. If the bit was set, it has entered a leader receiver role, where it now should receive data from the follower. In either case, an unlimited number of bytes can be transferred in one direction during the transmission.

At the end of the transmission, the leader either transmits a repeated START condition (Sr) if it wishes to continue with another transfer, or transmits a STOP condition (P) if it wishes to release the bus. When operating in the leader mode, I2CCLK frequency must be higher than 2 MHz for Standard-mode, 9 MHz for Fast-mode, and 20 MHz for Fast-mode Plus.

22.3.8.1 Leader State Machine

The leader state machine is shown in [Figure 22.16 I2C Leader State Machine on page 711](#). A leader operation starts in the far left of the state machine, and follows the solid lines through the state machine, ending the operation or continuing with a new operation when arriving at the right side of the state machine.

Branches in the path through the state machine are the results of bus events and choices made by software, either directly or indirectly. The dotted lines show where I²C-specific interrupt flags are set along the path and the full-drawn circles show places where interaction may be required by software to let the transmission proceed.

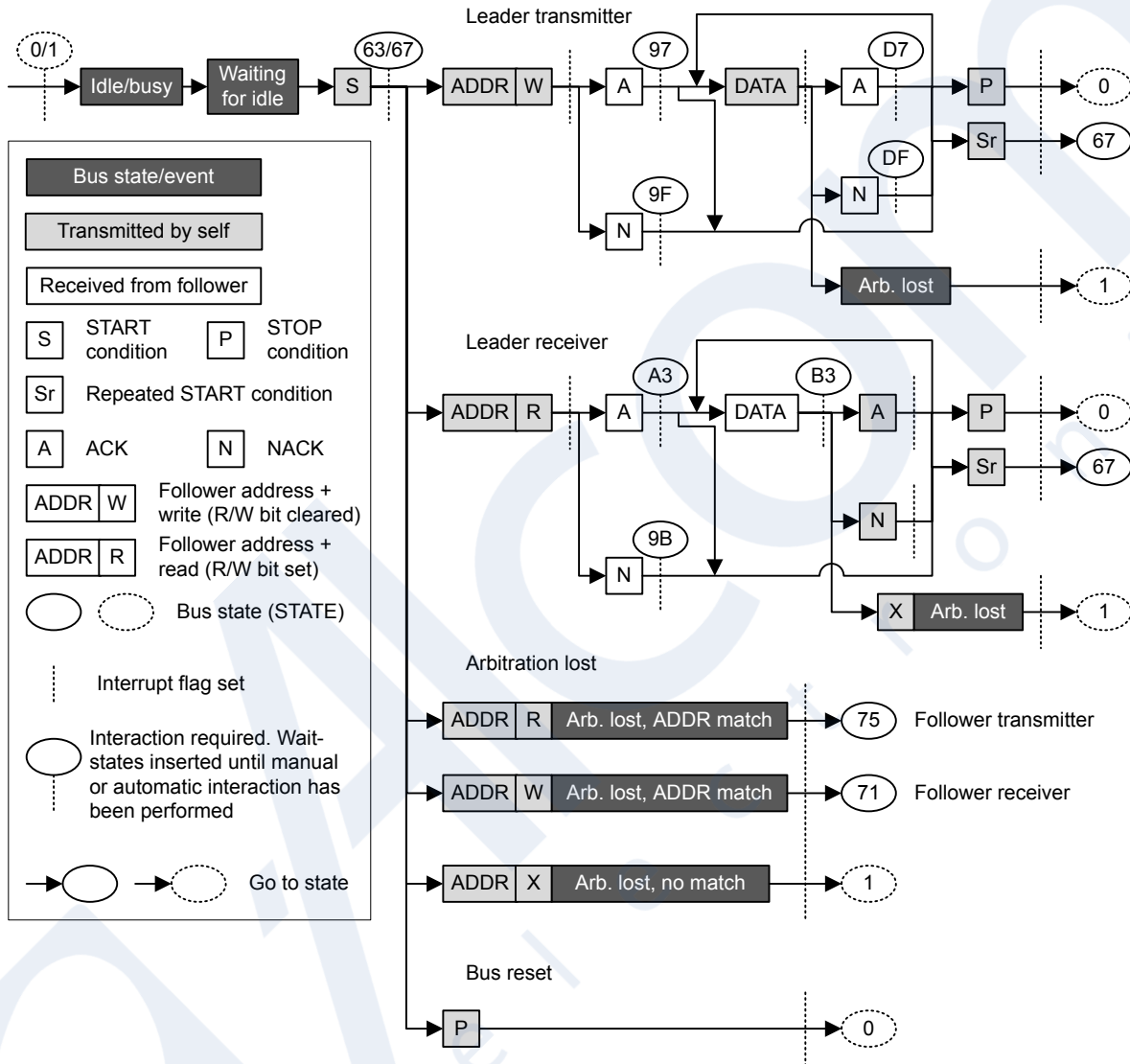

Figure 22.16. I2C Leader State Machine

22.3.8.2 Interactions

Whenever the I²C module is waiting for interaction from software, it holds the bus clock SCL low, freezing all bus activities, and the BUSHOLD interrupt flag in I2C_IF is set. The action(s) required by software depends on the current state the of the I²C module. This state can be read from the I2C_STATE register.

As an example, [Table 22.3 I2C Leader Transmitter on page 714](#) shows the different states the I²C goes through when operating as a Leader Transmitter, i.e., a leader that transmits data to a follower. As seen in the table, when a start condition has been transmitted, a requirement is that there is an address and an R/W bit in the transmit buffer. If the transmit buffer is empty, then the BUSHOLD interrupt flag is set, and the bus is held until data becomes available in the buffer. While waiting for the address, I2C_STATE has a value 0x67, which can be used to identify exactly what the I²C module is waiting for.

Note: The bus would never stop at state 0x67 if the address was available in the transmit buffer.

The BUSHOLD interrupt flag needs to be manually cleared by software after the appropriate action has been taken.

The different interactions used by the I²C module are listed in [Table 22.2 I2C Interactions in Prioritized Order on page 712](#) in a prioritized order. If the I²C module is in such a state that multiple courses of action are possible, then the action chosen is the one that has the highest priority. For example, after sending out a START, if an address is present in the buffer and a STOP is also pending, then the I²C will send out the STOP since it has the higher priority.

Table 22.2. I2C Interactions in Prioritized Order

Interaction	Priority	Software action	Automatically continues if
STOP*	1	Set the STOP command bit in I2C_CMD	PSTOP is set (STOP pending) in I2C_STATUS
ABORT	2	Set the ABORT command bit in I2C_CMD	Never, the transmission is aborted
CONT*	3	Set the CONT command bit in I2C_CMD	PCONT is set in I2C_STATUS (CONT pending)
NACK*	4	Set the NACK command bit in I2C_CMD	PNACK is set in I2C_STATUS (NACK pending)
ACK*	5	Set the ACK command bit in I2C_CMD	AUTOACK is set in I2C_CTRL or PACK is set in I2C_STATUS (ACK pending)
ADDR+W -> TXDATA	6	Write an address to the transmit buffer with the R/W bit set	Address is available in transmit buffer with R/W bit set
ADDR+R -> TXDATA	7	Write an address to the transmit buffer with the R/W bit cleared	Address is available in transmit buffer with R/W bit cleared
START*	8	Set the START command bit in I2C_CMD	PSTART is set in I2C_STATUS (START pending)
TXDATA/ TXDOUBLE	9	Write data to the transmit buffer	Data is available in transmit buffer
RXDATA/ RXDOUBLE	10	Read data from receive buffer	Space is available in receive buffer
None	11	No interaction is required	

The commands marked with a * in [Table 22.2 I2C Interactions in Prioritized Order on page 712](#) can be issued before an interaction is required. When such a command is issued before it can be used/consumed by the I²C module, the command is set in a pending state, which can be read from the STATUS register. A pending START command can for instance be identified by PSTART having a high value.

Whenever the I²C module requires an interaction, it checks the pending commands. If one or a combination of these can fulfill an interaction, they are consumed by the module and the transmission continues without setting the BUSHOLD interrupt flag in I2C_IF to get an interaction from software. The pending status of a command goes low when it is consumed.

When several interactions are possible from a set of pending commands, the interaction with the highest priority, i.e., the interaction closest to the top of [Table 22.2 I2C Interactions in Prioritized Order on page 712](#) is applied to the bus.

Pending commands can be cleared by setting the CLEARPC command bit in I2C_CMD.

22.3.8.3 Automatic ACK Interaction

When receiving addresses and data, an ACK command in I2C_CMD is normally required after each received byte. When AUTOACK is set in I2C_CTRL, an ACK is always pending, and the ACK-pending bit PACK in I2C_STATUS is thus always set, even after an ACK has been consumed. This is used when data is picked using I2C_RXDOUBLE and can also be used with I2C_RXDATA in order to reduce the amount of software interaction required during a transfer.

22.3.8.4 Reset State

After a reset, the state of the I²C-bus is unknown. To avoid interrupting transfers on the I²C-bus after a reset of the I²C module or the entire MCU, the I²C-bus is assumed to be busy when coming out of a reset, and the BUSY flag in I2C_STATUS is thus set. To be able to carry through leader operations on the I²C-bus, the bus must be idle.

The bus goes idle when a STOP condition is detected on the bus, but on buses with little activity, the time before the I²C module detects that the bus is idle can be significant. There are two ways of assuring that the I²C module gets out of the busy state.

- Use the ABORT command in I2C_CMD. When the ABORT command is issued, the I²C module is instructed that the bus is idle. The I²C module can then initiate leader operations.
- Use the Bus Idle Timeout. When SCL has been high for a long period of time, it is very likely that the bus is idle. Set BITO in I2C_CTRL to an appropriate timeout period and set GIBITO in I2C_CTRL. If activity has not been detected on the bus within the timeout period, the bus is then automatically assumed idle, and leader operations can be initiated.

Note: If operating in follower mode, the above approach is not necessary.

22.3.8.5 Leader Transmitter

To transmit data to a follower, the leader must operate as a leader transmitter. [Table 22.3 I2C Leader Transmitter on page 714](#) shows the states the I²C module goes through while acting as a leader transmitter. Every state where an interaction is required has the possible interactions listed, along with the result of the interactions. The table also shows which interrupt flags are set in the different states. The interrupt flags enclosed in parenthesis may be set. If the BUSHOLD interrupt in I2C_IF is set, the module is waiting for an interaction, and the bus is frozen. The value of I2C_STATE will be equal to the values given in the table when the BUSHOLD interrupt flag is set, and can be used to determine which interaction is required to make the transmission continue.

The interrupt flag START in I2C_IF is set when the I²C module transmits the START.

A leader operation is started by issuing a START command by setting START in I2C_CMD. ADDR+W, i.e., the address of the follower + the R/W bit is then required by the I²C module. If this is not available in the transmit buffer, then the bus is held and the BUSHOLD interrupt flag is set. The value of I2C_STATE will then be 0x67. As seen in the table, the I²C module also stops in this state if the address is not available after a repeated start condition.

To continue, write a byte to I2C_TXDATA with the address of the follower in the 7 most significant bits and the least significant bit cleared (ADDR+W). This address will then be transmitted, and the follower will reply with an ACK or a NACK. If no follower replies to the address, the response will also be NACK. If the address was acknowledged, the leader now has four choices. It can send data by placing it in I2C_TXDATA/ I2C_TXDOUBLE (the leader should check the TXBL interrupt flag before writing to the transmit buffer), this data is then transmitted. The leader can also stop the transmission by sending a STOP, it can send a repeated start by sending START, or it can send a STOP and then a START as soon as possible. If the leader wishes to make another transfer immediately after the current, the preferred way is to start a new transfer directly by transmitting a repeated START instead of a STOP followed by a START. This is so because if a STOP is sent out, then any leader wishing to initiate a transfer on the bus can try to gain control of it.

If a NACK was received, the leader has to issue a CONT command in addition to providing data in order to continue transmission. This is not standard I²C, but is provided for flexibility. The rest of the options are similar to when an ACK was received.

If a new byte was transmitted, an ACK or NACK is received after the transmission of the byte, and the leader has the same options as for when the address was sent.

The leader may lose arbitration at any time during transmission. In this case, the ARBLOST interrupt flag in I2C_IF is set. If the arbitration was lost during the transfer of an address, and SLAVE in I2C_CTRL is set, the leader then checks which address was transmitted. If it was the address of the leader, then the leader goes to follower mode.

After a leader has transmitted a START and won any arbitration, it owns the bus until it transmits a STOP. After a STOP, the bus is released, and arbitration decides which bus leader gains the bus next. The MSTOP interrupt flag in I2C_IF is set when a STOP condition is transmitted by the leader.

Table 22.3. I2C Leader Transmitter

I2C_STATE	Description	I2C_IF	Required interaction	Response
0x67	Start transmitted	START interrupt flag (BUSHOLD interrupt flag)	ADDR+W -> TXDATA	ADDR+W will be sent
			STOP	STOP will be sent and bus released.
			STOP + START	STOP will be sent and bus released. Then a START will be sent when bus becomes idle.
0x67	Repeated start transmitted	START interrupt flag (BUSHOLD interrupt flag)	ADDR+W -> TXDATA	ADDR+W will be sent
			STOP	STOP will be sent and bus released.
			STOP + START	STOP will be sent and bus released. Then a START will be sent when bus becomes idle.
-	ADDR+W transmitted	TXBL interrupt flag (TXC interrupt flag)	None	

I2C_STATE	Description	I2C_IF	Required interaction	Response
0x97	ADDR+W transmitted, ACK received	ACK interrupt flag (BUSHOLD interrupt flag)	TXDATA	DATA will be sent
			STOP	STOP will be sent. Bus will be released
			START	Repeated start condition will be sent
			STOP + START	STOP will be sent and the bus released. Then a START will be sent when the bus becomes idle
0x9F	ADDR+W transmitted, NACK received	NACK (BUSHOLD interrupt flag)	CONT + TXDATA	DATA will be sent
			STOP	STOP will be sent. Bus will be released
			START	Repeated start condition will be sent
			STOP + START	STOP will be sent and the bus released. Then a START will be sent when the bus becomes idle
-	Data transmitted	TXBL interrupt flag (TXC interrupt flag)	None	
0xD7	Data transmitted, ACK received	ACK interrupt flag (BUSHOLD interrupt flag)	TXDATA	DATA will be sent
			STOP	STOP will be sent. Bus will be released
			START	Repeated start condition will be sent
			STOP + START	STOP will be sent and the bus released. Then a START will be sent when the bus becomes idle
0xDF	Data transmitted, NACK received	NACK (BUSHOLD interrupt flag)	CONT + TXDATA	DATA will be sent
			STOP	STOP will be sent. Bus will be released
			START	Repeated start condition will be sent
			STOP + START	STOP will be sent and the bus released. Then a START will be sent when the bus becomes idle
-	Stop transmitted	MSTOP interrupt flag	None	
			START	START will be sent when bus becomes idle
-	Arbitration lost	ARBLOST interrupt flag	None	
			START	START will be sent when bus becomes idle

22.3.8.6 Leader Receiver

To receive data from a follower, the leader must operate as a leader receiver, see [Table 22.4 I2C Leader Receiver on page 716](#). This is done by transmitting ADDR+R as the address byte instead of ADDR+W, which is transmitted to become a leader transmitter. The address byte loaded into the data register thus has to contain the 7-bit follower address in the 7 most significant bits of the byte, and have the least significant bit set.

When the address has been transmitted, the leader receives an ACK or a NACK. If an ACK is received, the ACK interrupt flag in I2C_IF is set, and if space is available in the receive shift register, reception of a byte from the follower begins. If the receive buffer and shift register is full however, the bus is held until data is read from the receive buffer or another interaction is made. Note that the STOP and START interactions have a higher priority than the data-available interaction, so if a STOP or START command is pending, the highest priority interaction will be performed, and data will not be received from the follower.

If a NACK was received, the CONT command in I2C_CMD has to be issued in order to continue receiving data, even if there is space available in the receive buffer and/or shift register.

After a data byte has been received the leader must ACK or NACK the received byte. If an ACK is pending or AUTOACK in I2C_CTRL is set, an ACK is sent automatically and reception continues if space is available in the receive buffer.

If a NACK is sent, the CONT command must be used in order to continue transmission. If an ACK or NACK is issued along with a START or STOP or both, then the ACK/NACK is transmitted and the reception is ended. If START in I2C_CMD is set alone, a repeated start condition is transmitted after the ACK/NACK. If STOP in I2C_CMD is set, a stop condition is sent regardless of whether START is set. If START is set in this case, it is set as pending.

As when operating as a leader transmitter, arbitration can be lost as a leader receiver. When this happens the ARBLOST interrupt flag in I2C_IF is set, and the leader has a possibility of being selected as a follower given the correct conditions.

Table 22.4. I2C Leader Receiver

I2C_STATE	Description	I2C_IF	Required interaction	Response
0x63	START transmitted	START interrupt flag (BUSHOLD interrupt flag)	ADDR+R -> TXDATA	ADDR+R will be sent
			STOP	STOP will be sent and bus released.
			STOP + START	STOP will be sent and bus released. Then a START will be sent when bus becomes idle.
0x67	Repeated START transmitted	START interrupt flag(BUSHOLD interrupt flag)	ADDR+R -> TXDATA	ADDR+R will be sent
			STOP	STOP will be sent and bus released.
			STOP + START	STOP will be sent and bus released. Then a START will be sent when bus becomes idle.
-	ADDR+R transmitted	TXBL interrupt flag (TXC interrupt flag)	None	
0xA3	ADDR+R transmitted, ACK received	ACK interrupt flag(BUSHOLD)	RXDATA	Start receiving
			STOP	STOP will be sent and the bus released
			START	Repeated START will be sent
			STOP + START	STOP will be sent and the bus released. Then a START will be sent when the bus becomes idle
0x9B	ADDR+R transmitted, NACK received	NACK(BUSHOLD)	CONT + RXDATA	Continue, start receiving
			STOP	STOP will be sent and the bus released
			START	Repeated START will be sent
			STOP + START	STOP will be sent and the bus released. Then a START will be sent when the bus becomes idle

I2C_STATE	Description	I2C_IF	Required interaction	Response
0xB3	Data received	RXDATA interrupt flag(BUSHOLD interrupt flag)	ACK + RXDATA	ACK will be transmitted, reception continues
			NACK + CONT + RXDATA	NACK will be transmitted, reception continues
			ACK/NACK + STOP	ACK/NACK will be sent and the bus will be released.
			ACK/NACK + START	ACK/NACK will be sent, and then a repeated start condition.
			ACK/NACK + STOP + START	ACK/NACK will be sent and the bus will be released. Then a START will be sent when the bus becomes idle
-	Stop received	MSTOP interrupt flag	None	
			START	START will be sent when bus becomes idle
-	Arbitration lost	ARBLOST interrupt flag	None	
			START	START will be sent when bus becomes idle

22.3.8.7 SDA/SCL Status Monitor

The I²C module supports an SDA and SCL monitoring function. Note that this functionality is only supported when the I2C module is in single leader mode, and when the follower doesn't use clock stretching. Additionally, firmware should set the ARBDIS bit in I2C_CTRL when using the SDA/SCL monitoring to prevent the bus being released.

The SDA monitor is enabled by setting the SDAMONEN in I2C_CTRL. Once enabled, the SDA monitor will check the status of the SDA line at the following points:

- At a Start Condition, before SDA falls
- At Stop Condition, after SDA rises

After checking, the monitor will set the SDAERR flag in I2C_IF if it fails to read SDA==1. To allow the SDAERR flag to generate an IRQ, set the SDAERR bit in I2C_IEN.

Similarly, the SCL monitor is enabled by setting the SCLMONEN in I2C_CTRL. Once enabled, the SCL monitor will check the status of the SCL line at the following points:

- At a Start Condition, before SCL falls
- At every clock cycle, before SCL falls
- At Stop Condition, after SCL rises

After checking, the monitor will set the SCLERR flag in I2C_IF if it fails to read SCL==1. To allow the SCLERR flag to generate an IRQ, set the SCLERR bit in I2C_IEN.

22.3.9 Bus States

The I2C_STATE register can be used to determine which state the I²C module and the I²C bus are in at a given time. The register consists of the STATE bit-field, which shows which state the I²C module is at in any ongoing transmission, and a set of single-bits, which reveal the transmission mode, whether the bus is busy or idle, and whether the bus is held by this I²C module waiting for a software response.

The possible values of the STATE field are summarized in [Table 22.5 I2C STATE Values on page 718](#). When this field is cleared, the I²C module is not a part of any ongoing transmission. The remaining status bits in the I2C_STATE register are listed in [Table 22.6 I2C Transmission Status on page 718](#).

Table 22.5. I2C STATE Values

Mode	Value	Description
IDLE	0	No transmission is being performed by this module.
WAIT	1	Waiting for idle. Will send a start condition as soon as the bus is idle.
START	2	Start transmit phase
ADDR	3	Address transmit or receive phase
ADDRACK	4	Address ACK/NACK transmit or receive phase
DATA	5	Data transmit or receive phase
DATAACK	6	Data ACK/NACK transmit or receive phase

Table 22.6. I2C Transmission Status

Bit	Description
BUSY	Set whenever there is activity on the bus. Whether or not this module is responsible for the activity cannot be determined by this byte.
MASTER	Set when operating as a leader. Cleared at all other times.
TRANSMITTER	Set when operating as a transmitter; either a leader transmitter or a follower transmitter. Cleared at all other times
BUSHOLD	Set when the bus is held by this I ² C module because an action is required by software.
NACK	Only valid when bus is held and STATE is ADDRACK or DATAACK. In that case it is set if a NACK was received. In all other cases, the bit is cleared.

Note: I2C_STATE reflects the internal state of the I²C module, and therefore only held constant as long as the bus is held, i.e., as long as BUSHOLD in I2C_STATUS is set.

22.3.10 Follower Operation

The I²C module operates in leader mode by default. To enable follower operation, i.e., to allow the device to be addressed as an I²C follower, the SLAVE bit in I2C_CTRL must be set. In this case the I²C module operates in a mixed mode, both capable of starting transmissions as a leader, and being addressed as a follower. When operating in the follower mode, I2CCLK frequency must be higher than 2 MHz for Standard-mode, 5 MHz for Fast-mode, and 14 MHz for Fast-mode Plus.

22.3.10.1 Follower State Machine

The follower state machine is shown in [Figure 22.17 I²C Follower State Machine on page 719](#). The dotted lines show where I²C-specific interrupt flags are set. The full-drawn circles show places where interaction may be required by software to let the transmission proceed.

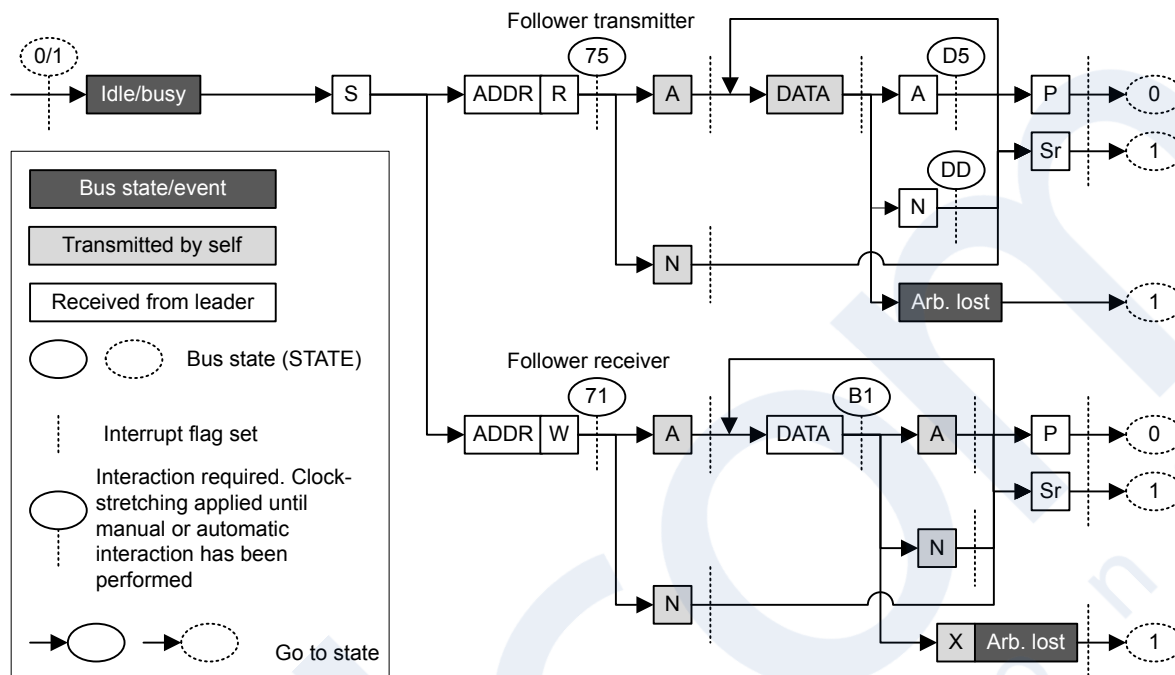

Figure 22.17. I²C Follower State Machine

22.3.10.2 Address Recognition

The I²C module provides automatic address recognition for 7-bit addresses. 10-bit address recognition is not fully automatic, but can be assisted by the 7-bit address comparator as shown in [22.3.12 Using 10-bit Addresses](#). Address recognition is supported in EM2/3 for I2C0 - however, the I2C0 module must be configured to use pins on either Port A or B if wakeup on address recognition from EM2/3 is desired. All other ports are available only in EM0/1. See GPIO chapter for more details.

The follower address, i.e., the address which the I²C module should be addressed with, is defined in the I2C_SADDR register. In addition to the address, a mask must be specified, telling the address comparator which bits of an incoming address to compare with the address defined in I2C_SADDR. The mask is defined in I2C_SADDRMASK, and for every zero in the mask, the corresponding bit in the follower address is treated as a don't-care, i.e., the 0-masked bits are ignored.

An incoming address that fails address recognition is automatically replied to with a NACK. Since only the bits defined by the mask are checked, a mask with a value 0x00 will result in all addresses being accepted. A mask with a value 0x7F will only match the exact address defined in I2C_SADDR, while a mask 0x70 will match all addresses where the three most significant bits in I2C_SADDR and the incoming address are equal.

If GCAMEN in I2C_CTRL is not set, the start-byte, i.e., the general call address with the R/W bit set is ignored unless it is included in the defined follower address and the address mask.

When an address is accepted by the address comparator, the decision of whether to ACK or NACK the address is passed to software.

22.3.10.3 Follower Transmitter

When SLAVE in I2C_CTRL is set, the RSTART interrupt flag in I2C_IF will be set when repeated START conditions are detected. After a START or repeated START condition, the bus leader will transmit an address along with an R/W bit. If there is no room in the receive shift register for the address, the bus will be held by the follower until room is available in the shift register. Transmission then continues and the address is loaded into the shift register. If this address does not pass address recognition, it is automatically NACK'ed by the follower, and the follower goes to an idle state. The address byte is in this case discarded, making the shift register ready for a new address. It is not loaded into the receive buffer.

If the address was accepted and the R/W bit was set (R), indicating that the leader wishes to read from the follower, the follower now goes into the follower transmitter mode. Software interaction is now required to decide whether the follower wants to acknowledge the request or not. The accepted address byte is loaded into the receive buffer like a regular data byte. If no valid interaction is pending, the bus is held until the follower responds with a command. The follower can reject the request with a single NACK command.

The follower will in that case go to an idle state, and wait for the next start condition. To continue the transmission, the follower must make sure data is loaded into the transmit buffer and send an ACK. The loaded data will then be transmitted to the leader, and an ACK or NACK will be received from the leader.

Data transmission can also continue after a NACK if a CONT command is issued along with the NACK. This is not standard I²C however.

If the leader responds with an ACK, it may expect another byte of data, and data should be made available in the transmit buffer. If data is not available, the bus is held until data is available.

If the response is a NACK however, this is an indication of that the leader has received enough bytes and wishes to end the transmission. The follower now automatically goes idle, unless CONT in I2C_CMD is set and data is available for transmission. The latter is not standard I²C.

The leader ends the transmission by sending a STOP or a repeated START. The SSTOP interrupt flag in I2C_IF is set when the leader transmits a STOP condition. If the transmission is ended with a repeated START, then the SSTOP interrupt flag is not set.

Note: The SSTOP interrupt flag in I2C_IF will be set regardless of whether the follower is participating in the transmission or not, as long as SLAVE in I2C_CTRL is set and a STOP condition is detected

If arbitration is lost at any time during transmission, the ARBLOST interrupt flag in I2C_IF is set, the bus is released and the follower goes idle.

See [Table 22.7 I2C Follower Transmitter on page 720](#) for more information.

Table 22.7. I2C Follower Transmitter

I2C_STATE	Description	I2C_IF	Required interaction	Response
0x01	Repeated START received	RSTART interrupt flag (BUSHOLD interrupt flag)	RXDATA	Receive and compare address
0x75	ADDR + R received	ADDR interrupt flag	ACK + TXDATA	ACK will be sent, then DATA
		RXDATA interrupt flag	NACK	NACK will be sent, follower goes idle
		(BUSHOLD interrupt flag)	NACK + CONT + TXDATA	NACK will be sent, then DATA.
-	Data transmitted	TXBL interrupt flag (TXC interrupt flag)	None	
0xD5	Data transmitted, ACK received	ACK interrupt flag (BUSHOLD interrupt flag)	TXDATA	DATA will be transmitted
0xDD	Data transmitted, NACK received	NACK interrupt flag	None	The follower goes idle
		(BUSHOLD interrupt flag)	CONT + TXDATA	DATA will be transmitted

I2C_STATE	Description	I2C_IF	Required interaction	Response
-	Stop received	SSTOP interrupt flag	None	The follower goes idle
			START	START will be sent when bus becomes idle
-	Arbitration lost	ARBLOST interrupt flag	None	The follower goes idle
			START	START will be sent when the bus becomes idle

22.3.10.4 Follower Receiver

A follower receiver operation is started in the same way as a follower transmitter operation, with the exception that the address transmitted by the leader has the R/W bit cleared (W), indicating that the leader wishes to write to the follower. The follower then goes into follower receiver mode.

To receive data from the leader, the follower should respond to the address with an ACK and make sure space is available in the receive buffer. Transmission will then continue, and the follower will receive a byte from the leader.

If a NACK is sent without a CONT, the transmission is ended for the follower, and it goes idle. If the follower issues both the NACK and CONT commands and has space available in the receive buffer, it will be open for continuing reception from the leader.

When a byte has been received from the leader, the follower must ACK or NACK the byte. The responses here are the same as for the reception of the address byte.

The leader ends the transmission by sending a STOP or a repeated START. The SSTOP interrupt flag is set when the leader transmits a STOP condition. If the transmission is ended with a repeated START, then the SSTOP interrupt flag in I2C_IF is not set.

Note: The SSTOP interrupt flag in I2C_IF will be set regardless of whether the follower is participating in the transmission or not, as long as SLAVE in I2C_CTRL is set and a STOP condition is detected

If arbitration is lost at any time during transmission, the ARBLOST interrupt flag in I2C_IF is set, the bus is released and the follower goes idle.

See [Table 22.8 I2C - Follower Receiver on page 722](#) for more information.

Table 22.8. I2C - Follower Receiver

I2C_STATE	Description	I2C_IF	Required interaction	Response
0x01	Repeated START received	RSTART interrupt flag (BUSHOLD interrupt flag)	RXDATA	Receive and compare address
0x71	ADDR + W received	ADDR interrupt flag RXDATA interrupt flag (BUSHOLD interrupt flag)	ACK + RXDATA	ACK will be sent and data will be received
			NACK	NACK will be sent, follower goes idle
			NACK + CONT + RXDATA	NACK will be sent and DATA will be received.
0xB1	Data received	RXDATA interrupt flag (BUSHOLD interrupt flag)	ACK + RXDATA	ACK will be sent and data will be received
			NACK	NACK will be sent and follower will go idle
			NACK + CONT + RXDATA	NACK will be sent and data will be received
-	Stop received	SSTOP interrupt flag	None	The follower goes idle
			START	START will be sent when bus becomes idle
-	Arbitration lost	ARBLOST interrupt flag	None	The follower goes idle
			START	START will be sent when the bus becomes idle

22.3.11 Transfer Automation

The I²C can be set up to complete transfers with a minimal amount of interaction.

22.3.11.1 DMA

DMA can be used to automatically load data into the transmit buffer and load data out from the receive buffer. When using DMA, software is thus relieved of moving data to and from memory after each transferred byte.

22.3.11.2 Automatic ACK

When AUTOACK in I2C_CTRL is set, an ACK is sent automatically whenever an ACK interaction is possible and no higher priority interactions are pending.

22.3.11.3 Automatic STOP

A STOP can be generated automatically on two conditions. These apply only to the leader transmitter.

If AUTOSN in I2C_CTRL is set, the I²C module ends a transmission by transmitting a STOP condition when operating as a leader transmitter and a NACK is received.

If AUTOSE in I2C_CTRL is set, the I²C module always ends a transmission when there is no more data in the transmit buffer. If data has been transmitted on the bus, the transmission is ended after the (N)ACK has been received by the follower. If a START is sent when no data is available in the transmit buffer and AUTOSE is set, then the STOP condition is sent immediately following the START. Software must thus make sure data is available in the transmit buffer before the START condition has been fully transmitted if data is to be transferred.

22.3.12 Using 10-bit Addresses

When using 10-bit addresses in follower mode, set the I2C_SADDR register to 1111 0XX where XX are the two most significant bits of the 10-bit address, and set I2C_SADDRMASK to 0xFF. Address matches will now be given on all 10-bit addresses where the two most significant bits are correct.

When receiving an address match, the follower must acknowledge the address and receive the first data byte. This byte contains the second part of the 10-bit address. If it matches the address of the follower, the follower should ACK the byte to continue the transmission, and if it does not match, the follower should NACK it.

When the leader is operating as a leader transmitter, the data bytes will follow after the second address byte. When the leader is operating as a leader receiver however, a repeated START condition is sent after the second address byte. The address sent after this repeated START is equal to the first of the address bytes transmitted previously, but now with the R/W byte set, and only the follower that found a match on the entire 10-bit address in the previous message should ACK this address. The repeated start should take the leader into a leader receiver mode, and after the single address byte sent this time around, the follower begins transmission to the leader.

22.3.13 Error Handling

Note: Some registers in the I²C module are considered static. This means that these need to be set before an I²C transaction starts and need to stay stable during the entire transaction.

Specifically:

- The GCAMEN and SLAVE fields in the I2C_CTRL register
- The I2C_SADDR register
- The GPIO_I2Cn_ROUTEEN, GPIO_I2Cn_SCLROUTE, and GPIO_I2Cn_SDARROUTE registers

22.3.13.1 ABORT Command

Some bus errors may require software intervention to be resolved. The I²C module provides an ABORT command, which can be set in I2C_CMD, to help resolve bus errors.

When the bus for some reason is locked up and the I²C module is in the middle of a transmission it cannot get out of, or for some other reason the I²C wants to abort a transmission, the ABORT command can be used.

Setting the ABORT command will make the I²C module discard any data currently being transmitted or received, release the SDA and SCL lines and go to an idle mode. ABORT effectively makes the I²C module forget about any ongoing transfers.

22.3.13.2 Bus Reset

A bus reset can be performed by setting the START and STOP commands in I2C_CMD while the transmit buffer is empty. A START condition will then be transmitted, immediately followed by a STOP condition. A bus reset can also be performed by transmitting a START command with the transmit buffer empty and AUTOSE set.

22.3.13.3 I²C-Bus Errors

An I²C-bus error occurs when a START or STOP condition is misplaced, which happens when the value on SDA changes while SCL is high during bit-transmission on the I²C-bus. If the I²C module is part of the current transmission when a bus error occurs, any data currently being transmitted or received is discarded, SDA and SCL are released, the BUSERR interrupt flag in I2C_IF is set to indicate the error, and the module automatically takes a course of action as defined in [Table 22.9 I²C Bus Error Response on page 724](#).

Table 22.9. I²C Bus Error Response

	Misplaced START	Misplaced STOP
In a leader/follower operation	Treated as START. Receive address.	Go idle. Perform any pending actions.

22.3.13.4 Bus Lockup

A lockup occurs when a leader or follower on the I²C-bus has locked the SDA or SCL at a low value, preventing other devices from putting high values on the bus, and thus making communication on the bus impossible.

Many follower-only devices operating on an I²C-bus are not capable of driving SCL low, but in the rare case that SCL is stuck LOW, the advice is to apply a hardware reset signal to the followers on the bus. If this does not work, cycle the power to the devices in order to make them release SCL.

When SDA is stuck low and SCL is free, a leader should send 9 clock pulses on SCL while tristating the SDA. This procedure is performed in the GPIO module after clearing the GPIO_I2Cn_ROUTEEN register and disabling the I2C module. The device that held the bus low should release it sometime within those 9 clocks. If not, use the same approach as for when SCL is stuck, resetting and possibly cycling power to the followers.

Lockup of SDA can be detected by keeping count of the number of continuous arbitration losses during address transmission. If arbitration is also lost during the transmission of a general call address, i.e., during the transmission of the STOP condition, which should never happen during normal operation, this is a good indication of SDA lockup.

Detection of SCL lockups can be done using the timeout functionality defined in [22.3.13.6 Clock Low Timeout](#)

22.3.13.5 Bus Idle Timeout

When SCL has been high for a significant amount of time, this is a good indication of that the bus is idle. On an SMBus system, the bus is only allowed to be in this state for a maximum of 50 μ s before the bus is considered idle.

The bus idle timeout BITO in I2C_CTRL can be used to detect situations where the bus goes idle in the middle of a transmission. The timeout can be configured in BITO, and when the bus has been idle for the given amount of time, the BITO interrupt flag in I2C_IF is set. The bus can also be set idle automatically on a bus idle timeout. This is enabled by setting GIBITO in I2C_CTRL.

When the bus idle timer times out, it wraps around and continues counting as long as its condition is true. If the bus is not set idle using GIBITO or the ABORT command in I2C_CMD, this will result in periodic timeouts.

Note: This timeout will be generated even if SDA is held low.

The bus idle timeout is active as long as the bus is busy, i.e., BUSY in I2C_STATUS is set. The timeout can be used to get the I²C module out of the busy-state it enters when reset, see [22.3.8.4 Reset State](#).

22.3.13.6 Clock Low Timeout

The clock timeout, which can be configured in CLTO in I2C_CTRL, starts counting whenever SCL goes low, and times out if SCL does not go high within the configured timeout. A clock low timeout results in CLTOIF in I2C_IF being set, allowing software to take action.

When the timer times out, it wraps around and continues counting as long as SCL is low. An SCL lockup will thus result in periodic clock low timeouts as long as SCL is low.

22.3.13.7 Clock Low Error

The I²C module can continue transmission in parallel with another device for the entire transaction, as long as the two communications are identical. A case may arise when (before an arbitration has been decided upon) the I²C module decides to send out a repeated START or a STOP condition while the other device is still sending data. In the I²C protocol specifications, such a combination results in an undefined condition. The I²C deals with this by generating a clock low error. This means that if the I²C is transmitting a repeated START or a STOP condition and another device (another leader or a misbehaving follower) pulls SCL low before the I²C sends out the START/STOP condition on SDA, a clock low error is generated. The CLERR interrupt flag is then set in the I2C_IF register, any held lines are released and the I²C device goes to idle.

22.3.14 DMA Support

The I²C module has full DMA support. A request for the DMA controller to write to the I²C transmit buffer can come from TXBL (transmit buffer has room for more data). The DMA controller can write to the transmit buffer using the I2C_TXDATA or the I2C_TXDOUBLE register. DMA must be configured to transfer one byte of data when writing to the I2C_TXDATA and configured for transferring two bytes of data when writing to the I2C_TXDOUBLE.

A request for the DMA controller to read from the I²C receive buffer can come from RXDATAV (data available in the receive buffer). DMA must be configured to transfer one byte of data when reading from I2C_RXDATA and configured for transferring two bytes of data when reading from I2C_RXDOUBLE.

22.3.15 Interrupts

The interrupts generated by the I²C module are combined into one interrupt vector, I2C_INT. If I²C interrupts are enabled, an interrupt will be made if one or more of the interrupt flags in I2C_IF and their corresponding bits in I2C_IEN are set.

22.3.16 Wake-up

The I²C receive section can be active all the way down to energy mode EM3 stop, and can wake up the CPU on address interrupt. All address match modes are supported.

22.4 I2C Register Map

The offset register address is relative to the registers base address.

Offset	Name	Type	Description
0x000	I2C_IPVERSION	R	IP VERSION Register
0x004	I2C_EN	RW	Enable Register
0x008	I2C_CTRL	RW	Control Register
0x00C	I2C_CMD	W	Command Register
0x010	I2C_STATE	RH	State Register
0x014	I2C_STATUS	RH	Status Register
0x018	I2C_CLKDIV	RW	Clock Division Register
0x01C	I2C_SADDR	RW	Follower Address Register
0x020	I2C_SADDRMASK	RW	Follower Address Mask Register
0x024	I2C_RXDATA	RH	Receive Buffer Data Register
0x028	I2C_RXDOUBLE	RH	Receive Buffer Double Data Register
0x02C	I2C_RXDATAP	RH	Receive Buffer Data Peek Register
0x030	I2C_RXDOUBLEP	RH	Receive Buffer Double Data Peek Register
0x034	I2C_TXDATA	W	Transmit Buffer Data Register
0x038	I2C_TXDOUBLE	W	Transmit Buffer Double Data Register
0x03C	I2C_IF	RWH INTFLAG	Interrupt Flag Register
0x040	I2C_IEN	RW	Interrupt Enable Register
0x1000	I2C_IPVERSION_SET	R	IP VERSION Register
0x1004	I2C_EN_SET	RW	Enable Register
0x1008	I2C_CTRL_SET	RW	Control Register
0x100C	I2C_CMD_SET	W	Command Register
0x1010	I2C_STATE_SET	RH	State Register
0x1014	I2C_STATUS_SET	RH	Status Register
0x1018	I2C_CLKDIV_SET	RW	Clock Division Register
0x101C	I2C_SADDR_SET	RW	Follower Address Register
0x1020	I2C_SADDRMASK_SET	RW	Follower Address Mask Register
0x1024	I2C_RXDATA_SET	RH	Receive Buffer Data Register
0x1028	I2C_RXDOUBLE_SET	RH	Receive Buffer Double Data Register
0x102C	I2C_RXDATAP_SET	RH	Receive Buffer Data Peek Register
0x1030	I2C_RXDOUBLEP_SET	RH	Receive Buffer Double Data Peek Register
0x1034	I2C_TXDATA_SET	W	Transmit Buffer Data Register
0x1038	I2C_TXDOUBLE_SET	W	Transmit Buffer Double Data Register
0x103C	I2C_IF_SET	RWH INTFLAG	Interrupt Flag Register
0x1040	I2C_IEN_SET	RW	Interrupt Enable Register
0x2000	I2C_IPVERSION_CLR	R	IP VERSION Register

Offset	Name	Type	Description
0x2004	I2C_EN_CLR	RW	Enable Register
0x2008	I2C_CTRL_CLR	RW	Control Register
0x200C	I2C_CMD_CLR	W	Command Register
0x2010	I2C_STATE_CLR	RH	State Register
0x2014	I2C_STATUS_CLR	RH	Status Register
0x2018	I2C_CLKDIV_CLR	RW	Clock Division Register
0x201C	I2C_SADDR_CLR	RW	Follower Address Register
0x2020	I2C_SADDRMASK_CLR	RW	Follower Address Mask Register
0x2024	I2C_RXDATA_CLR	RH	Receive Buffer Data Register
0x2028	I2C_RXDOUBLE_CLR	RH	Receive Buffer Double Data Register
0x202C	I2C_RXDATAP_CLR	RH	Receive Buffer Data Peek Register
0x2030	I2C_RXDOUBLEP_CLR	RH	Receive Buffer Double Data Peek Register
0x2034	I2C_TXDATA_CLR	W	Transmit Buffer Data Register
0x2038	I2C_TXDOUBLE_CLR	W	Transmit Buffer Double Data Register
0x203C	I2C_IF_CLR	RWH INTFLAG	Interrupt Flag Register
0x2040	I2C_IEN_CLR	RW	Interrupt Enable Register
0x3000	I2C_IPVERSION_TGL	R	IP VERSION Register
0x3004	I2C_EN_TGL	RW	Enable Register
0x3008	I2C_CTRL_TGL	RW	Control Register
0x300C	I2C_CMD_TGL	W	Command Register
0x3010	I2C_STATE_TGL	RH	State Register
0x3014	I2C_STATUS_TGL	RH	Status Register
0x3018	I2C_CLKDIV_TGL	RW	Clock Division Register
0x301C	I2C_SADDR_TGL	RW	Follower Address Register
0x3020	I2C_SADDRMASK_TGL	RW	Follower Address Mask Register
0x3024	I2C_RXDATA_TGL	RH	Receive Buffer Data Register
0x3028	I2C_RXDOUBLE_TGL	RH	Receive Buffer Double Data Register
0x302C	I2C_RXDATAP_TGL	RH	Receive Buffer Data Peek Register
0x3030	I2C_RXDOUBLEP_TGL	RH	Receive Buffer Double Data Peek Register
0x3034	I2C_TXDATA_TGL	W	Transmit Buffer Data Register
0x3038	I2C_TXDOUBLE_TGL	W	Transmit Buffer Double Data Register
0x303C	I2C_IF_TGL	RWH INTFLAG	Interrupt Flag Register
0x3040	I2C_IEN_TGL	RW	Interrupt Enable Register

22.5 I2C Register Description

22.5.1 I2C_IPVERSION - IP VERSION Register

Offset	Bit Position																															
0x000	31	30	29	28	27	26	25	24	23	22	21	20	19	18	17	16	15	14	13	12	11	10	9	8	7	6	5	4	3	2	1	0
Reset																																0x0
Access																																R
Name																																IPVERSION

Bit	Name	Reset	Access	Description
31:0	IPVERSION	0x0	R	IP version ID The read only IPVERSION field gives the version for this module. There may be minor software changes required for modules with different values of IPVERSION.

22.5.2 I2C_EN - Enable Register

Offset	Bit Position																															
0x004	31	30	29	28	27	26	25	24	23	22	21	20	19	18	17	16	15	14	13	12	11	10	9	8	7	6	5	4	3	2	1	0
Reset																																0x0
Access																																RW
Name																																EN

Bit	Name	Reset	Access	Description
31:1	<i>Reserved</i>	<i>To ensure compatibility with future devices, always write Reserved bits to their reset value, unless otherwise stated. More information in 1.2 Conventions</i>		
0	EN	0x0	RW	module enable The ENABLE bit enables the module. Software should write to CONFIG type registers before setting the ENABLE bit. Software should write to SYNC type registers only after setting the ENABLE bit.
	Value	Mode	Description	
	0	DISABLE	Disable Peripheral Clock	
	1	ENABLE	Enable Peripheral Clock	

22.5.3 I2C_CTRL - Control Register

Offset	Bit Position																																									
0x008	31	30	29	28	27	26	25	24	23	22	21	20	19	18	17	16	15	14	13	12	11	10	9	8	7	6	5	4	3	2	1	0										
Reset												0x0	0x0			0x0		0x0			0x0			0x0				0x0	0x0	0x0	0x0	0x0	0x0	0x0	0x0	0x0	0x0	0x0	0x0	0x0		
Access												RW	RW			RW		RW			RW			RW				RW	RW	RW	RW	RW	RW	RW	RW	RW	RW	RW	RW	RW	RW	RW
Name												SDAMONEN	SCLMONEN			CLTO		GIBITO			BITO							CLHR	TXBIL	GCAMEN	ARBDIS	AUTOSN	AUTOSE	AUTOACK	SLAVE	CORERST						

Bit	Name	Reset	Access	Description																		
31:22	<i>Reserved</i>	<i>To ensure compatibility with future devices, always write Reserved bits to their reset value, unless otherwise stated. More information in 1.2 Conventions</i>																				
21	SDAMONEN	0x0	RW	SDA Monitor Enable Set to enable SDA monitor feature. This will enable SDA rise check at loopback path. This monitor can not be enabled in Multi-Leader application <table border="1"> <thead> <tr> <th>Value</th> <th>Mode</th> <th>Description</th> </tr> </thead> <tbody> <tr> <td>0</td> <td>DISABLE</td> <td>Disable SDA Monitor</td> </tr> <tr> <td>1</td> <td>ENABLE</td> <td>Enable SDA Monitor</td> </tr> </tbody> </table>	Value	Mode	Description	0	DISABLE	Disable SDA Monitor	1	ENABLE	Enable SDA Monitor									
Value	Mode	Description																				
0	DISABLE	Disable SDA Monitor																				
1	ENABLE	Enable SDA Monitor																				
20	SCLMONEN	0x0	RW	SCL Monitor Enable Set to enable SCL monitor feature. This will enable SCL rise check at loopback path. This monitor can not be enabled in Multi-Leader application <table border="1"> <thead> <tr> <th>Value</th> <th>Mode</th> <th>Description</th> </tr> </thead> <tbody> <tr> <td>0</td> <td>DISABLE</td> <td>Disable SCL monitor</td> </tr> <tr> <td>1</td> <td>ENABLE</td> <td>Enable SCL monitor</td> </tr> </tbody> </table>	Value	Mode	Description	0	DISABLE	Disable SCL monitor	1	ENABLE	Enable SCL monitor									
Value	Mode	Description																				
0	DISABLE	Disable SCL monitor																				
1	ENABLE	Enable SCL monitor																				
19	<i>Reserved</i>	<i>To ensure compatibility with future devices, always write Reserved bits to their reset value, unless otherwise stated. More information in 1.2 Conventions</i>																				
18:16	CLTO	0x0	RW	Clock Low Timeout Use to generate a timeout when CLK has been low for the given amount of time. Wraps around and continues counting when the timeout is reached. The timeout value can be calculated by $timeout = PCC / (F_{scl} \times (N_{low} + N_{high}))$ <table border="1"> <thead> <tr> <th>Value</th> <th>Mode</th> <th>Description</th> </tr> </thead> <tbody> <tr> <td>0</td> <td>OFF</td> <td>Timeout disabled</td> </tr> <tr> <td>1</td> <td>I2C40PCC</td> <td>Timeout after 40 prescaled clock cycles. In standard mode at 100 kHz, this results in a 50us timeout.</td> </tr> <tr> <td>2</td> <td>I2C80PCC</td> <td>Timeout after 80 prescaled clock cycles. In standard mode at 100 kHz, this results in a 100us timeout.</td> </tr> <tr> <td>3</td> <td>I2C160PCC</td> <td>Timeout after 160 prescaled clock cycles. In standard mode at 100 kHz, this results in a 200us timeout.</td> </tr> <tr> <td>4</td> <td>I2C320PCC</td> <td>Timeout after 320 prescaled clock cycles. In standard mode at 100 kHz, this results in a 400us timeout.</td> </tr> </tbody> </table>	Value	Mode	Description	0	OFF	Timeout disabled	1	I2C40PCC	Timeout after 40 prescaled clock cycles. In standard mode at 100 kHz, this results in a 50us timeout.	2	I2C80PCC	Timeout after 80 prescaled clock cycles. In standard mode at 100 kHz, this results in a 100us timeout.	3	I2C160PCC	Timeout after 160 prescaled clock cycles. In standard mode at 100 kHz, this results in a 200us timeout.	4	I2C320PCC	Timeout after 320 prescaled clock cycles. In standard mode at 100 kHz, this results in a 400us timeout.
Value	Mode	Description																				
0	OFF	Timeout disabled																				
1	I2C40PCC	Timeout after 40 prescaled clock cycles. In standard mode at 100 kHz, this results in a 50us timeout.																				
2	I2C80PCC	Timeout after 80 prescaled clock cycles. In standard mode at 100 kHz, this results in a 100us timeout.																				
3	I2C160PCC	Timeout after 160 prescaled clock cycles. In standard mode at 100 kHz, this results in a 200us timeout.																				
4	I2C320PCC	Timeout after 320 prescaled clock cycles. In standard mode at 100 kHz, this results in a 400us timeout.																				

Bit	Name	Reset	Access	Description
	5	I2C1024PCC		Timeout after 1024 prescaled clock cycles. In standard mode at 100 kHz, this results in a 1280us timeout.
15	GIBITO	0x0	RW	Go Idle on Bus Idle Timeout When set, the bus automatically goes idle on a bus idle timeout, allowing new transfers to be initiated.
	Value	Mode		Description
	0	DISABLE		A bus idle timeout has no effect on the bus state.
	1	ENABLE		A bus idle timeout tells the I2C module that the bus is idle, allowing new transfers to be initiated.
14	<i>Reserved</i>	<i>To ensure compatibility with future devices, always write Reserved bits to their reset value, unless otherwise stated. More information in 1.2 Conventions</i>		
13:12	BITO	0x0	RW	Bus Idle Timeout Use to generate a timeout when SCL has been high for a given amount time between a START and STOP condition. When in a bus transaction, i.e. the BUSY flag is set, a timer is started whenever SCL goes high. When the timer reaches the value defined by BITO, it sets the BITO interrupt flag. The BITO interrupt flag will then be set periodically as long as SCL remains high. The bus idle timeout is active as long as BUSY is set. It is thus stopped automatically on a timeout if GIBITO is set. It is also stopped a STOP condition is detected and when the ABORT command is issued. The timeout is activated whenever the bus goes BUSY, i.e. a START condition is detected. The timeout value can be calculated by $timeout = PCC / (F_{scl} \times (N_{low} + N_{high}))$
	Value	Mode		Description
	0	OFF		Timeout disabled
	1	I2C40PCC		Timeout after 40 prescaled clock cycles. In standard mode at 100 kHz, this results in a 50us timeout.
	2	I2C80PCC		Timeout after 80 prescaled clock cycles. In standard mode at 100 kHz, this results in a 100us timeout.
	3	I2C160PCC		Timeout after 160 prescaled clock cycles. In standard mode at 100 kHz, this results in a 200us timeout.
11:10	<i>Reserved</i>	<i>To ensure compatibility with future devices, always write Reserved bits to their reset value, unless otherwise stated. More information in 1.2 Conventions</i>		
9:8	CLHR	0x0	RW	Clock Low High Ratio Determines the values of (and ratio between) the low and high parts of the clock signal generated on SCL as leader.
	Value	Mode		Description
	0	STANDARD		N _{low} =4 and N _{high} =4, and the N _{low} :N _{high} ratio is 4:4
	1	ASYMMETRIC		N _{low} =6 and N _{high} =3, and the N _{low} :N _{high} ratio is 6:3
	2	FAST		N _{low} =11 and N _{high} =6, and the N _{low} :N _{high} ratio is 11:6
7	TXBIL	0x0	RW	TX Buffer Interrupt Level Determines the interrupt and status level of the transmit buffer.
	Value	Mode		Description
	0	EMPTY		TXBL status and the TXBL interrupt flag are set when the transmit buffer becomes empty. TXBL is cleared when the buffer becomes nonempty.

Bit	Name	Reset	Access	Description
	1	HALF_FULL		TXBL status and the TXBL interrupt flag are set when the transmit buffer goes from full to half-full or empty. TXBL is cleared when the buffer becomes full
6	GCAMEN	0x0	RW	General Call Address Match Enable Set to enable address match on general call in addition to the programmed follower address.
	Value	Mode		Description
	0	DISABLE		General call address will be NACK'ed if it is not included by the follower address and address mask.
	1	ENABLE		When a general call address is received, a software response is required
5	ARBDIS	0x0	RW	Arbitration Disable A leader or follower will not release the bus upon losing arbitration.
	Value	Mode		Description
	0	DISABLE		When a device loses arbitration, the ARBIF interrupt flag is set and the bus is released.
	1	ENABLE		When a device loses arbitration, the ARBIF interrupt flag is set, but communication proceeds.
4	AUTOSN	0x0	RW	Automatic STOP on NACK Write to 1 to make a leader transmitter send a STOP when a NACK is received from a follower.
	Value	Mode		Description
	0	DISABLE		Stop is not automatically sent if a NACK is received from a follower.
	1	ENABLE		The leader automatically sends a STOP if a NACK is received from a follower.
3	AUTOSE	0x0	RW	Automatic STOP when Empty Write to 1 to make a leader transmitter send a STOP when no more data is available for transmission.
	Value	Mode		Description
	0	DISABLE		A stop must be sent manually when no more data is to be transmitted.
	1	ENABLE		The leader automatically sends a STOP when no more data is available for transmission.
2	AUTOACK	0x0	RW	Automatic Acknowledge Set to enable automatic acknowledges.
	Value	Mode		Description
	0	DISABLE		Software must give one ACK command for each ACK transmitted on the I2C bus.
	1	ENABLE		Addresses that are not automatically NACK'ed, and all data is automatically acknowledged.
1	SLAVE	0x0	RW	Addressable as Follower

Bit	Name	Reset	Access	Description
				Set this bit to allow the device to be selected as an I2C follower.
	Value	Mode		Description
	0	DISABLE		All addresses will be responded to with a NACK
	1	ENABLE		Addresses matching the programmed follower address or the general call address (if enabled) require a response from software. Other addresses are automatically responded to with a NACK.
0	CORERST	0x0	RW	Soft Reset the internal state registers
				Set to reset the I2C_STATE register, and return the I2C module to the IDLE state. Must clear this bit to resume normal operation condition
	Value	Mode		Description
	0	DISABLE		No change to internal state registers
	1	ENABLE		Reset the internal state registers

22.5.4 I2C_CMD - Command Register

Offset	Bit Position																																																						
0x00C	31	30	29	28	27	26	25	24	23	22	21	20	19	18	17	16	15	14	13	12	11	10	9	8	7	6	5	4	3	2	1	0																							
Reset																									0x0	0x0	0x0	0x0	0x0	0x0	0x0	0x0	0x0	0x0	0x0	0x0	0x0	0x0	0x0	0x0	0x0	0x0	0x0	0x0	0x0	0x0	0x0	0x0	0x0	0x0	0x0	0x0	0x0	0x0	0x0
Access																									W(nB)	W(nB)	W(nB)	W(nB)	W(nB)	W(nB)	W(nB)	W(nB)	W(nB)	W(nB)	W(nB)	W(nB)	W(nB)	W(nB)	W(nB)	W(nB)	W(nB)	W(nB)	W(nB)	W(nB)	W(nB)	W(nB)	W(nB)	W(nB)	W(nB)	W(nB)	W(nB)	W(nB)	W(nB)	W(nB)	W(nB)
Name																									CLEARPC	CLEARTX	ABORT	CONT	NACK	ACK	STOP	START																							

Bit	Name	Reset	Access	Description
31:8	<i>Reserved</i>	<i>To ensure compatibility with future devices, always write Reserved bits to their reset value, unless otherwise stated. More information in 1.2 Conventions</i>		
7	CLEARPC	0x0	W(nB)	Clear Pending Commands Set to clear pending commands.
6	CLEARTX	0x0	W(nB)	Clear TX Set to clear transmit buffer and shift register. Will not abort ongoing transfer.
5	ABORT	0x0	W(nB)	Abort transmission Abort the current transmission making the bus go idle. When used in combination with STOP, a STOP condition is sent as soon as possible before aborting the transmission. The stop condition is subject to clock synchronization.
4	CONT	0x0	W(nB)	Continue transmission Set to continue transmission after a NACK has been received.
3	NACK	0x0	W(nB)	Send NACK Set to transmit a NACK the next time an acknowledge is required.
2	ACK	0x0	W(nB)	Send ACK Set to transmit an ACK the next time an acknowledge is required.
1	STOP	0x0	W(nB)	Send stop condition Set to send stop condition as soon as possible.
0	START	0x0	W(nB)	Send start condition Set to send start condition as soon as possible. If a transmission is ongoing and not owned, the start condition will be sent as soon as the bus is idle. If the current transmission is owned by this module, a repeated start condition will be sent. Use in combination with a STOP command to automatically send a STOP, then a START when the bus becomes idle.

22.5.5 I2C_STATE - State Register

Offset	Bit Position																															
0x010	31	30	29	28	27	26	25	24	23	22	21	20	19	18	17	16	15	14	13	12	11	10	9	8	7	6	5	4	3	2	1	0
Reset																								0x0	0x0	0x0	0x0	0x0	0x1			
Access																								R	R	R	R	R	R			
Name																								STATE	BUSHOLD	NACKED	TRANSMITTER	MASTER	BUSY			

Bit	Name	Reset	Access	Description																								
31:8	<i>Reserved</i>	<i>To ensure compatibility with future devices, always write Reserved bits to their reset value, unless otherwise stated. More information in 1.2 Conventions</i>																										
7:5	STATE	0x0	R	<p>Transmission State</p> <p>The state of any current transmission. Cleared if the I2C module is idle.</p> <table border="1"> <thead> <tr> <th>Value</th> <th>Mode</th> <th>Description</th> </tr> </thead> <tbody> <tr> <td>0</td> <td>IDLE</td> <td>No transmission is being performed.</td> </tr> <tr> <td>1</td> <td>WAIT</td> <td>Waiting for idle. Will send a start condition as soon as the bus is idle.</td> </tr> <tr> <td>2</td> <td>START</td> <td>Start transmit phase</td> </tr> <tr> <td>3</td> <td>ADDR</td> <td>Address transmit or receive phase</td> </tr> <tr> <td>4</td> <td>ADDRACK</td> <td>Address ack/nack transmit or receive phase</td> </tr> <tr> <td>5</td> <td>DATA</td> <td>Data transmit or receive phase</td> </tr> <tr> <td>6</td> <td>DATAACK</td> <td>Data ack/nack transmit or receive phase</td> </tr> </tbody> </table>	Value	Mode	Description	0	IDLE	No transmission is being performed.	1	WAIT	Waiting for idle. Will send a start condition as soon as the bus is idle.	2	START	Start transmit phase	3	ADDR	Address transmit or receive phase	4	ADDRACK	Address ack/nack transmit or receive phase	5	DATA	Data transmit or receive phase	6	DATAACK	Data ack/nack transmit or receive phase
Value	Mode	Description																										
0	IDLE	No transmission is being performed.																										
1	WAIT	Waiting for idle. Will send a start condition as soon as the bus is idle.																										
2	START	Start transmit phase																										
3	ADDR	Address transmit or receive phase																										
4	ADDRACK	Address ack/nack transmit or receive phase																										
5	DATA	Data transmit or receive phase																										
6	DATAACK	Data ack/nack transmit or receive phase																										
4	BUSHOLD	0x0	R	<p>Bus Held</p> <p>Set if the bus is currently being held by this I2C module.</p>																								
3	NACKED	0x0	R	<p>Nack Received</p> <p>Set if a NACK was received and STATE is ADDRACK or DATAACK.</p>																								
2	TRANSMITTER	0x0	R	<p>Transmitter</p> <p>Set when operating as a leader transmitter or a follower transmitter. When cleared, the system may be operating as a leader receiver, a follower receiver or the current mode is not known.</p>																								
1	MASTER	0x0	R	<p>Leader</p> <p>Set when operating as an I2C leader. When cleared, the system may be operating as an I2C follower.</p>																								
0	BUSY	0x1	R	<p>Bus Busy</p> <p>Set when the bus is busy. Whether the I2C module is in control of the bus or not has no effect on the value of this bit. When the MCU comes out of reset, the state of the bus is not known, and thus BUSY is set. Use the ABORT command or a bus idle timeout to force the I2C module out of the BUSY state.</p>																								

22.5.6 I2C_STATUS - Status Register

Offset	Bit Position																																																				
0x014	31	30	29	28	27	26	25	24	23	22	21	20	19	18	17	16	15	14	13	12	11	10	9	8	7	6	5	4	3	2	1	0																					
Reset																					0x0	0x0	0x0	0x1	0x0	0x0	0x0	0x0	0x0	0x0	0x0	0x0	0x0	0x0	0x0	0x0	0x0	0x0	0x0	0x0	0x0	0x0	0x0	0x0	0x0	0x0	0x0	0x0	0x0	0x0	0x0	0x0	
Access																					R	R	R	R	R	R	R	R	R	R	R	R	R	R	R	R	R	R	R	R	R	R	R	R	R	R	R	R	R	R	R	R	R
Name																					TXBUFCNT	RXFULL	RXDATAV	TXBL	TXC	PABORT	PCONT	PNACK	PACK	PSTOP	PSTART																						

Bit	Name	Reset	Access	Description
31:12	<i>Reserved</i>	<i>To ensure compatibility with future devices, always write Reserved bits to their reset value, unless otherwise stated. More information in 1.2 Conventions</i>		
11:10	TXBUFCNT	0x0	R	TX Buffer Count Indicates the number of buffers filled with valid data and not transmit to tx shift register
9	RXFULL	0x0	R	RX FIFO Full Set when the receive buffer is full. Cleared when the receive buffer is no longer full. When this bit is set, there is still room for one more frame in the receive shift register.
8	RXDATAV	0x0	R	RX Data Valid Set when data is available in the receive buffer. Cleared when the receive buffer is empty.
7	TXBL	0x1	R	TX Buffer Level Indicates the level of the transmit buffer. if TXBIL==0, set when the transmit buffer is empty. if TXBIL==1, set when the transmit buffer is half full
6	TXC	0x0	R	TX Complete Set when a transmission has completed and no more data is available in the transmit buffer. Cleared when a new transmission starts.
5	PABORT	0x0	R	Pending abort An abort is pending and will be transmitted as soon as possible.
4	PCONT	0x0	R	Pending continue A continue is pending and will be transmitted as soon as possible.
3	PNACK	0x0	R	Pending NACK A not-acknowledge is pending and will be transmitted as soon as possible.
2	PACK	0x0	R	Pending ACK An acknowledge is pending and will be transmitted as soon as possible.
1	PSTOP	0x0	R	Pending STOP A stop condition is pending and will be transmitted as soon as possible.
0	PSTART	0x0	R	Pending START A start condition is pending and will be transmitted as soon as possible.

22.5.7 I2C_CLKDIV - Clock Division Register

Offset	Bit Position																															
0x018	31	30	29	28	27	26	25	24	23	22	21	20	19	18	17	16	15	14	13	12	11	10	9	8	7	6	5	4	3	2	1	0
Reset																									0x0							
Access																									RW							
Name																									DIV							

Bit	Name	Reset	Access	Description
31:9	Reserved	To ensure compatibility with future devices, always write Reserved bits to their reset value, unless otherwise stated. More information in 1.2 Conventions		
8:0	DIV	0x0	RW	Clock Divider Specifies the clock divider for the I2C. Note that DIV must be 1 or higher when follower is enabled.

22.5.8 I2C_SADDR - Follower Address Register

Offset	Bit Position																															
0x01C	31	30	29	28	27	26	25	24	23	22	21	20	19	18	17	16	15	14	13	12	11	10	9	8	7	6	5	4	3	2	1	0
Reset																									0x0							
Access																									RW							
Name																									ADDR							

Bit	Name	Reset	Access	Description
31:8	Reserved	To ensure compatibility with future devices, always write Reserved bits to their reset value, unless otherwise stated. More information in 1.2 Conventions		
7:1	ADDR	0x0	RW	Follower address Specifies the follower address of the device.
0	Reserved	To ensure compatibility with future devices, always write Reserved bits to their reset value, unless otherwise stated. More information in 1.2 Conventions		

22.5.9 I2C_SADDRMASK - Follower Address Mask Register

Offset	Bit Position																															
0x020	31	30	29	28	27	26	25	24	23	22	21	20	19	18	17	16	15	14	13	12	11	10	9	8	7	6	5	4	3	2	1	0
Reset																									0x0							
Access																									RW							
Name																									SADDRMASK							

Bit	Name	Reset	Access	Description
31:8	Reserved	To ensure compatibility with future devices, always write Reserved bits to their reset value, unless otherwise stated. More information in 1.2 Conventions		
7:1	SADDRMASK	0x0	RW	Follower Address Mask Specifies the significant bits of the follower address. Setting the mask to 0x00 will match all addresses, while setting it to 0x7F will only match the exact address specified by ADDR.
0	Reserved	To ensure compatibility with future devices, always write Reserved bits to their reset value, unless otherwise stated. More information in 1.2 Conventions		

22.5.10 I2C_RXDATA - Receive Buffer Data Register

Offset	Bit Position																															
0x024	31	30	29	28	27	26	25	24	23	22	21	20	19	18	17	16	15	14	13	12	11	10	9	8	7	6	5	4	3	2	1	0
Reset																									0x0							
Access																									R							
Name																									RXDATA							

Bit	Name	Reset	Access	Description
31:8	Reserved	To ensure compatibility with future devices, always write Reserved bits to their reset value, unless otherwise stated. More information in 1.2 Conventions		
7:0	RXDATA	0x0	R	RX Data Use this register to read from the receive buffer. Buffer is emptied on read access.

22.5.11 I2C_RXDOUBLE - Receive Buffer Double Data Register

Offset	Bit Position																															
0x028	31	30	29	28	27	26	25	24	23	22	21	20	19	18	17	16	15	14	13	12	11	10	9	8	7	6	5	4	3	2	1	0
Reset																	0x0								0x0							
Access																	R								R							
Name																	RXDATA1								RXDATA0							

Bit	Name	Reset	Access	Description
31:16	Reserved	<i>To ensure compatibility with future devices, always write Reserved bits to their reset value, unless otherwise stated. More information in 1.2 Conventions</i>		
15:8	RXDATA1	0x0	R	RX Data 1 Second byte read from buffer. Buffer is emptied on read access.
7:0	RXDATA0	0x0	R	RX Data 0 First byte read from buffer. Buffer is emptied on read access.

22.5.12 I2C_RXDATAP - Receive Buffer Data Peek Register

Offset	Bit Position																															
0x02C	31	30	29	28	27	26	25	24	23	22	21	20	19	18	17	16	15	14	13	12	11	10	9	8	7	6	5	4	3	2	1	0
Reset																									0x0							
Access																									R							
Name																									RXDATAP							

Bit	Name	Reset	Access	Description
31:8	Reserved	<i>To ensure compatibility with future devices, always write Reserved bits to their reset value, unless otherwise stated. More information in 1.2 Conventions</i>		
7:0	RXDATAP	0x0	R	RX Data Peek Use this register to read from the receive buffer. Buffer is not emptied on read access.

22.5.13 I2C_RXDOUBLEP - Receive Buffer Double Data Peek Register

Offset	Bit Position																															
0x030	31	30	29	28	27	26	25	24	23	22	21	20	19	18	17	16	15	14	13	12	11	10	9	8	7	6	5	4	3	2	1	0
Reset																	0x0								0x0							
Access																	R								R							
Name																	RXDATAP1								RXDATAPO							

Bit	Name	Reset	Access	Description
31:16	Reserved			To ensure compatibility with future devices, always write Reserved bits to their reset value, unless otherwise stated. More information in 1.2 Conventions
15:8	RXDATAP1	0x0	R	RX Data 1 Peek Second byte read from buffer. Buffer is not emptied on read access.
7:0	RXDATAPO	0x0	R	RX Data 0 Peek First byte read from buffer. Buffer is not emptied on read access.

22.5.14 I2C_TXDATA - Transmit Buffer Data Register

Offset	Bit Position																															
0x034	31	30	29	28	27	26	25	24	23	22	21	20	19	18	17	16	15	14	13	12	11	10	9	8	7	6	5	4	3	2	1	0
Reset																	0x0															
Access																	W(nB)															
Name																	TXDATA															

Bit	Name	Reset	Access	Description
31:8	Reserved			To ensure compatibility with future devices, always write Reserved bits to their reset value, unless otherwise stated. More information in 1.2 Conventions
7:0	TXDATA	0x0	W(nB)	TX Data Use this register to write a byte to the transmit buffer.

22.5.15 I2C_TXDOUBLE - Transmit Buffer Double Data Register

Offset	Bit Position																															
0x038	31	30	29	28	27	26	25	24	23	22	21	20	19	18	17	16	15	14	13	12	11	10	9	8	7	6	5	4	3	2	1	0
Reset																	0x0								0x0							
Access																	W(nB)								W(nB)							
Name																	TXDATA1								TXDATA0							

Bit	Name	Reset	Access	Description
31:16	<i>Reserved</i>	<i>To ensure compatibility with future devices, always write Reserved bits to their reset value, unless otherwise stated. More information in 1.2 Conventions</i>		
15:8	TXDATA1 Second byte to write to buffer.	0x0	W(nB)	TX Data
7:0	TXDATA0 First byte to write to buffer.	0x0	W(nB)	TX Data

22.5.16 I2C_IF - Interrupt Flag Register

Offset	Bit Position																																														
0x03C	31	30	29	28	27	26	25	24	23	22	21	20	19	18	17	16	15	14	13	12	11	10	9	8	7	6	5	4	3	2	1	0															
Reset												0x0	0x0	0x0	0x0	0x0	0x0	0x0	0x0	0x0	0x0	0x0	0x0	0x0	0x0	0x0	0x0	0x0	0x0	0x0	0x0	0x0	0x0	0x0	0x0	0x0	0x0	0x0	0x0	0x0	0x0	0x0	0x0				
Access												RW	RW	RW	RW	RW	RW	RW	RW	RW	RW	RW	RW	RW	RW	RW	RW	RW	RW	RW	RW	RW	RW	RW	RW	RW	RW	RW	RW	RW	RW	RW	RW	RW			
Name												SDAERR	SCLERR	CLERR	RXFULL	SSTOP	CLTO	BITO	RXUF	TXOF	BUSHOLD	BUSERR	ARBLOST	MSTOP	NACK	ACK	RXDATAV	TXBL	TXC	ADDR	RSTART	START															

Bit	Name	Reset	Access	Description
31:21	<i>Reserved</i>	<i>To ensure compatibility with future devices, always write Reserved bits to their reset value, unless otherwise stated. More information in 1.2 Conventions</i>		
20	SDAERR	0x0	RW	SDA Error Interrupt Flag Set when the SDA at loopback path is not equal to SDA output
19	SCLERR	0x0	RW	SCL Error Interrupt Flag Set when the SCL at loopback path is not equal to SCL output
18	CLERR	0x0	RW	Clock Low Error Interrupt Flag Set when the clock is pulled low before a START or a STOP condition could be transmitted.
17	RXFULL	0x0	RW	Receive Buffer Full Interrupt Flag Set when the receive buffer becomes full.
16	SSTOP	0x0	RW	Follower STOP condition Interrupt Flag Set when a STOP condition has been received. Will be set regardless of the follower being involved in the transaction or not.
15	CLTO	0x0	RW	Clock Low Timeout Interrupt Flag Set on each clock low timeout. The timeout value can be set in CLTO bit field in the I2Cn_CTRL register.
14	BITO	0x0	RW	Bus Idle Timeout Interrupt Flag Set on each bus idle timeout. The timeout value can be set in the BITO bit field in the I2Cn_CTRL register.
13	RXUF	0x0	RW	Receive Buffer Underflow Interrupt Flag Set when data is read from the receive buffer through the I2Cn_RXDATA register while the receive buffer is empty. It is also set when data is read through the I2Cn_RXDOUBLE while the buffer is not full.
12	TXOF	0x0	RW	Transmit Buffer Overflow Interrupt Flag Set when data is written to the transmit buffer while the transmit buffer is full.
11	BUSHOLD	0x0	RW	Bus Held Interrupt Flag Set when the bus becomes held by the I2C module.
10	BUSERR	0x0	RW	Bus Error Interrupt Flag Set when a bus error is detected. The bus error is resolved automatically, but the current transfer is aborted.
9	ARBLOST	0x0	RW	Arbitration Lost Interrupt Flag Set when arbitration is lost.
8	MSTOP	0x0	RW	Leader STOP Condition Interrupt Flag

Bit	Name	Reset	Access	Description
				Set when a STOP condition has been successfully transmitted. If arbitration is lost during the transmission of the STOP condition, then the MSTOP interrupt flag is not set.
7	NACK	0x0	RW	Not Acknowledge Received Interrupt Flag Set when a NACK has been received.
6	ACK	0x0	RW	Acknowledge Received Interrupt Flag Set when an ACK has been received.
5	RXDATAV	0x0	RW	Receive Data Valid Interrupt Flag Set when received data is half full
4	TXBL	0x0	RW	Transmit Buffer Level Interrupt Flag if TXBIL==0, set when the transmit buffer is empty. if TXBIL==1, set when the transmit is half full
3	TXC	0x0	RW	Transfer Completed Interrupt Flag Set when the transmit shift register becomes empty and there is no more data in the transmit buffer.
2	ADDR	0x0	RW	Address Interrupt Flag Set when incoming address is accepted, i.e. own address or general call address is received.
1	RSTART	0x0	RW	Repeated START condition Interrupt Flag Set when a repeated start condition is detected.
0	START	0x0	RW	START condition Interrupt Flag Set when a start condition is successfully transmitted.

22.5.17 I2C_IEN - Interrupt Enable Register

Offset	Bit Position																																														
0x040	31	30	29	28	27	26	25	24	23	22	21	20	19	18	17	16	15	14	13	12	11	10	9	8	7	6	5	4	3	2	1	0															
Reset												0x0	0x0	0x0	0x0	0x0	0x0	0x0	0x0	0x0	0x0	0x0	0x0	0x0	0x0	0x0	0x0	0x0	0x0	0x0	0x0	0x0	0x0	0x0	0x0	0x0	0x0	0x0	0x0	0x0	0x0	0x0	0x0				
Access												RW	RW	RW	RW	RW	RW	RW	RW	RW	RW	RW	RW	RW	RW	RW	RW	RW	RW	RW	RW	RW	RW	RW	RW	RW	RW	RW	RW	RW	RW	RW	RW	RW			
Name												SDAERR	SCLERR	CLERR	RXFULL	SSTOP	CLTO	BITO	RXUF	TXOF	BUSHOLD	BUSERR	ARBLOST	MSTOP	NACK	ACK	RXDATAV	TXBL	TXC	ADDR	RSTART	START															

Bit	Name	Reset	Access	Description
31:21	<i>Reserved</i>	<i>To ensure compatibility with future devices, always write Reserved bits to their reset value, unless otherwise stated. More information in 1.2 Conventions</i>		
20	SDAERR	0x0	RW	SDA Error Interrupt Flag Set when SDA at loopback path is not equal to SDA output
19	SCLERR	0x0	RW	SCL Error Interrupt Flag Set when SCL at loopback path is not equal to SCL output
18	CLERR	0x0	RW	Clock Low Error Interrupt Flag Set when the clock is pulled low before a START or a STOP condition could be transmitted.
17	RXFULL	0x0	RW	Receive Buffer Full Interrupt Flag Set when the receive buffer becomes full.
16	SSTOP	0x0	RW	Follower STOP condition Interrupt Flag Set when a STOP condition has been received. Will be set regardless of the follower being involved in the transaction or not.
15	CLTO	0x0	RW	Clock Low Timeout Interrupt Flag Set on each clock low timeout. The timeout value can be set in CLTO bit field in the I2Cn_CTRL register.
14	BITO	0x0	RW	Bus Idle Timeout Interrupt Flag Set on each bus idle timeout. The timeout value can be set in the BITO bit field in the I2Cn_CTRL register.
13	RXUF	0x0	RW	Receive Buffer Underflow Interrupt Flag Set when data is read from the receive buffer through the I2Cn_RXDATA register while the receive buffer is empty. It is also set when data is read through the I2Cn_RXDOUBLE while the buffer is not full.
12	TXOF	0x0	RW	Transmit Buffer Overflow Interrupt Flag Set when data is written to the transmit buffer while the transmit buffer is full.
11	BUSHOLD	0x0	RW	Bus Held Interrupt Flag Set when the bus becomes held by the I2C module.
10	BUSERR	0x0	RW	Bus Error Interrupt Flag Set when a bus error is detected. The bus error is resolved automatically, but the current transfer is aborted.
9	ARBLOST	0x0	RW	Arbitration Lost Interrupt Flag Set when arbitration is lost.
8	MSTOP	0x0	RW	Leader STOP Condition Interrupt Flag

Bit	Name	Reset	Access	Description
				Set when a STOP condition has been successfully transmitted. If arbitration is lost during the transmission of the STOP condition, then the MSTOP interrupt flag is not set.
7	NACK	0x0	RW	Not Acknowledge Received Interrupt Flag Set when a NACK has been received.
6	ACK	0x0	RW	Acknowledge Received Interrupt Flag Set when an ACK has been received.
5	RXDATAV	0x0	RW	Receive Data Valid Interrupt Flag Set when data is available in the receive buffer. Cleared automatically when the receive buffer is read.
4	TXBL	0x0	RW	Transmit Buffer Level Interrupt Flag Set when the transmit buffer becomes empty. Cleared automatically when new data is written to the transmit buffer.
3	TXC	0x0	RW	Transfer Completed Interrupt Flag Set when the transmit shift register becomes empty and there is no more data in the transmit buffer.
2	ADDR	0x0	RW	Address Interrupt Flag Set when incoming address is accepted, i.e. own address or general call address is received.
1	RSTART	0x0	RW	Repeated START condition Interrupt Flag Set when a repeated start condition is detected.
0	START	0x0	RW	START condition Interrupt Flag Set when a start condition is successfully transmitted.

23. IADC - Incremental Analog to Digital Converter

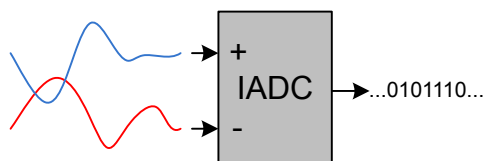
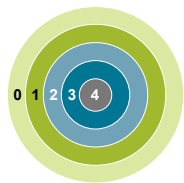

Quick Facts

What?

The IADC is used to convert analog voltages into a digital representation and features high-speed, low-power operation.

Why?

In many applications there is a need to measure analog signals and record them in a digital representation, without exhausting the energy source.

How?

The low power IADC samples one or more input channels in a programmable sequence. With the help of PRS and DMA, the IADC can operate without CPU intervention in EM2 and EM3, minimizing the number of powered up resources. The IADC can be automatically shut down between conversions to further reduce the energy consumption.

23.1 Introduction

The IADC uses an Incremental Successive Approximation Architecture, with a resolution of up to 12 bits when operating at two million samples per second (2 Msps). The flexible incremental architecture uses oversampling to allow applications to trade speed for higher resolution. A high-accuracy mode enables greater than 15 bits of noise-free resolution. An integrated input multiplexer can select from external I/Os and several internal signals.

23.2 Features

- Flexible oversampled architecture allows for tradeoffs between speed and resolution.
 - Normal Mode
 - 1 Msps with oversampling ratio = 2
 - 76.9 ksps with oversampling ratio = 32
 - High Speed Mode
 - 2 Msps with oversampling ratio = 2
 - 153.8 ksps with oversampling ratio = 32
 - High Accuracy Mode
 - 10.7 ksps with oversampling ratio = 92
 - 3.8 ksps with oversampling ratio = 256
- Digital post-averaging
- Internal and external conversion trigger sources
 - Immediate (software triggered)
 - Local IADC timer
 - External TIMER module (synchronous with output / PWM generation)
 - General PRS hardware signal
- Integrated prescaler for conversion clock generation
- Can be run during EM2 and EM3, waking up the system on interrupts as needed
- Selectable reference sources
 - 1.21 V internal reference
 - External precision reference
 - Analog supply
- Support for offset and gain calibration
- Programmable input gain: 0.5x, 1x, 2x, 3x, or 4x
- Flexible output formatting
 - Unipolar or 2's complement bipolar data
 - Results can be saved in 12 bit, 16 bit, or 20 bit format
 - Programmable left or right justification
 - Optional channel ID tag
- Digital window comparison function detects when results are inside/outside a programmable window
- Two independent groups of configuration registers for setting IADC mode, clock prescaler, reference selection, oversample rate, unipolar/bipolar output formatting, and analog gain
- Programmable single channel conversion
 - Can use either configuration group
 - Triggered by any conversion trigger source
 - Can be tailgated after a scan sequence
 - One shot or continuous mode
 - Local FIFO for immediate data storage
 - Programmable watermark level to generate interrupt or initiate DMA transfer
 - Supports overflow and underflow interrupt generation
 - Supports window compare function
- Autonomous multi-channel scan
 - Up to 16 configurable slots in scan sequence
 - Each slot allows independent selection of configuration group, channel selection, and window compare enable
 - Triggered by any conversion trigger source
 - One shot or continuous mode
 - Local FIFO for immediate data storage
 - Programmable watermark level to generate interrupt or initiate DMA transfer
 - Supports overflow and underflow interrupt generation
 - Conversion tailgating support for predictable periodic scans

- Available interrupt sources:
 - Single FIFO has DVL (data valid level) entries available (also generates DMA request)
 - Scan FIFO has DVL (data valid level) entries available (also generates DMA request)
 - Single FIFO result compared true for digital compare window
 - Scan FIFO result compared true for digital compare window
 - Single queue conversion has completed
 - Scan queue entry conversion has completed
 - Scan queue table conversion has completed
 - Single FIFO overflow or underflow
 - Scan FIFO overflow or underflow
 - Polarity Error interrupt
 - Port Allocation Error interrupt
 - EM23 clock configuration error

23.3 Functional Description

The incremental ADC module block diagram is shown in [Figure 23.1 IADC Overview on page 747](#).

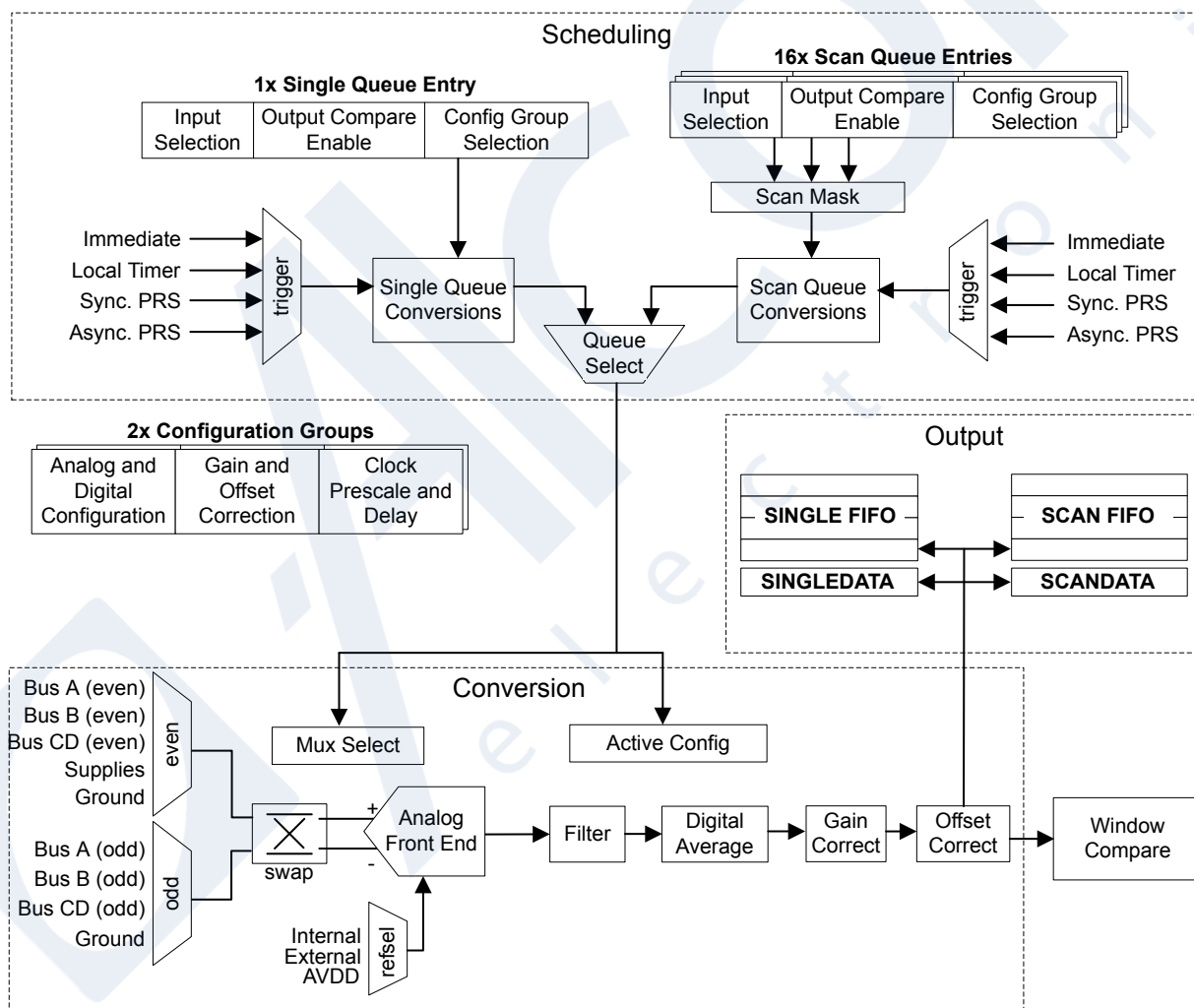

Figure 23.1. IADC Overview

23.3.1 Register Access

Many of the IADC module's configuration registers can only be written while the module is disabled ($IADC_EN_EN = 0$). These are $IADC_CTRL$, $IADC_TIMER$, $IADC_CMPTHR$, $IADC_TRIGGER$, $IADC_CFGx$, $IADC_SCALEx$, $IADC_SCHEDx$, and $IADC_SCANx$. A typical setup sequence for the IADC module is:

1. With the IADC disabled ($IADC_EN_EN = 0$), program all configuration registers listed above.
2. Enable the IADC by setting EN in $IADC_EN$ to 1.
3. Program the remaining configuration registers.
4. Enable the single or scan queue.
5. The IADC is ready for use.

23.3.2 Clocking

The IADC logic is partitioned into two clock domains: CLK_BUS (APBIF) and CLK_SRC_ADC (CORE). The APBIF domain contains the IADC registers and FIFO read logic. The rest of the IADC is clocked mainly by CLK_SRC_ADC and ADC_CLK, both of which are derived from CLK_CMU_ADC, as shown in .

CLK_CMU_ADC is the incoming clock routed to the ADC by the CMU, and may be up to 80 MHz. It is selected within the CMU module. If the ADC is to be used synchronously with an external TIMER module, the clock should be configured to derive from the group A clock. If configuring for operation in EM2 or EM3, a clock source available in EM2 and EM3 must be used directly, as the group A clock multiplexer will be shut down in EM2 and EM3.

CLK_SRC_ADC is derived from CLK_CMU_ADC, and must be no faster than 40 MHz. The HSCLKRATE field in IADC_CTRL sets the prescaler to divide CLK_CMU_ADC. If CLK_CMU_ADC is already 40 MHz or slower, HSCLKRATE can be set to 0x0 to pass the clock through to CLK_SRC_ADC without dividing it. CLK_SRC_ADC is the clock source used for the TIMEBASE prescaler as well as the local IADC timer.

ADC_CLK is used to drive the ADC front-end and state machine logic. Another prescaler is used to reduce CLK_SRC_ADC to a suitable frequency for the ADC operating mode. Different operational modes have different restrictions on the IADC clock speed. Because the operational mode may be different for single vs. scan conversions, or even for different conversions within a scan, each configuration group has a PRESCALE bit field in the IADC_SCHEx register.

When IADC_CFGx.ADCMODE is set to NORMAL, PRESCALE must be set to limit ADC_CLK to no faster than 10 MHz for 0.5x and 1x analog gain settings. For analog gain of 2x, 3x, and 4x, the maximum ADC_CLK is 5 MHz, 2.5 MHz, or 2.5 MHz respectively.

When IADC_CFGx.ADCMODE is set to HIGH SPEED, everything from NORMAL mode is scaled by a factor of 2. PRESCALE must be set to limit ADC_CLK to no faster than 20 MHz for 0.5x and 1x analog gain settings. For analog gain of 2x, 3x, and 4x, the maximum ADC_CLK is 10 MHz, 5 MHz, or 5 MHz respectively. It is recommended to run ADC_CLK no slower than 100 kHz.

When IADC_CFGx.ADCMODE is set to HIGH ACCURACY, PRESCALE must be set to limit ADC_CLK to no faster than 5 MHz, regardless of the analog gain setting.

These restrictions are summarized in [Table 23.1 Maximum ADC_CLK Speed vs Analog Gain and ADCMODE Settings on page 749](#).

Table 23.1. Maximum ADC_CLK Speed vs Analog Gain and ADCMODE Settings

Analog Gain	CFGx.ADCMODE = NORMAL	CFGx.ADCMODE = HIGH-SPEED	CFGx.ADCMODE = HIGH-ACCURACY
0.5 x	10 MHz	20 MHz	5 MHz
1 x	10 MHz	20 MHz	5 MHz
2 x	5 MHz	10 MHz	5 MHz
3 x	2.5 MHz	5 MHz	5 MHz
4 x	2.5 MHz	5 MHz	5 MHz

Note: If HSCLKRATE is configured to divide CLK_CMU_ADC by more than 1 (HSCLKRATE != 0), then PRESCALE must not be set to divide by 1 (PRESCALE = 0). When this condition is detected, a PRESCALE value of 1 (divide by 2) will be automatically be used instead of the programmed PRESCALE value.

The suspend mode fields IADC_CTRL_ADCCLKSUSPEND0 (for scan conversions) or IADC_CTRL_ADCCLKSUSPEND1 (for single conversions) can be used to shut down the clock between conversions and save power. The ADC logic will wake up the clock before starting IADC warmup and performing a conversion. If the suspend mode is set, the clock will shut down again once the conversion is complete.

When IADC_TRIGGER_SCANTRIGSEL or IADC_TRIGGER_SINGLETRIGSEL is set to IMMEDIATE, IADC_CTRL_ADCCLKSUSPENDn will force the clock to only be running when one of the queues is enabled.

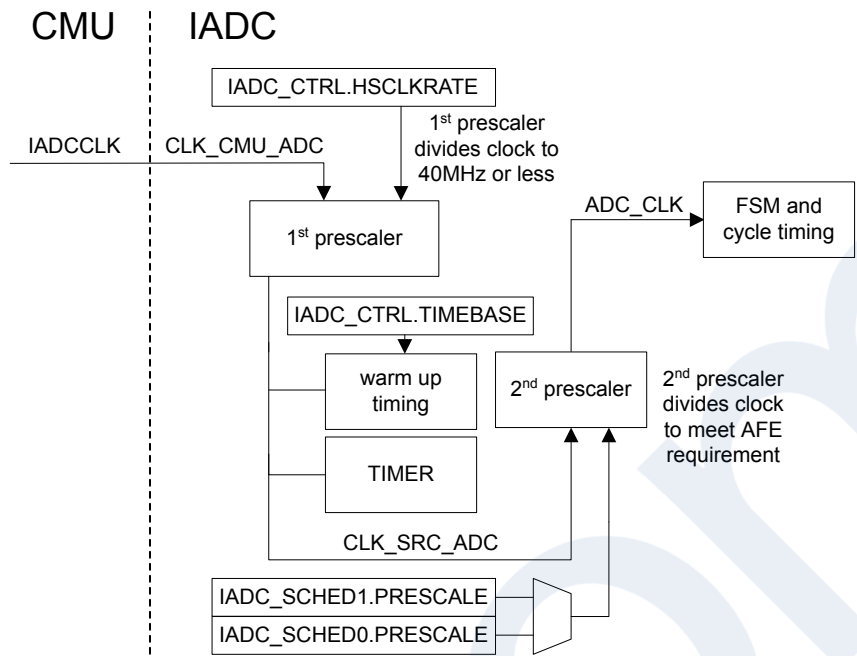

Figure 23.2. Clocking

23.3.3 Conversion Timing

The IADC takes multiple samples of the analog signal to produce each output. The number of input samples contributing to an output word is determined by the oversampling ratio (OSR). Higher OSR settings will improve the ADC's INL and DNL, and reduce system-level noise, but require more time for each conversion. Different OSRs may be specified for each configuration group. It is important to note that oversampling is an analog process which provides more input samples to the digital filter. For Normal and High-Speed modes, the OSR is configured with the OSRHS bit field in the IADC_CFGx register. The OSR options for High-Accuracy mode are different, and are configured with the OSRHA bit field in the IADC_CFGx register.

During a conversion, the effective front-end sampling frequency (F_{sample}) in Normal and High-Speed modes is equal to $ADC_CLK / 4$. In High-Accuracy mode, F_{sample} is $ADC_CLK / 5$.

23.3.3.1 Warmup Time

To save energy, the IADC can be configured to power down completely or enter a standby state between conversions, if full speed operation is not required for the application. The required ADC warm up time from a full powered-down state is 5 μ s. Warmup from a standby state requires 1 μ s. Warmup is automatically timed by the ADC logic when it is required, but software must configure the TIMEBASE field in IADC_CTRL for a minimum 1 μ s interval. Note that the TIMEBASE counter receives CLK_SRC_ADC, and should be programmed based on that frequency. For example, if CLK_SRC_ADC is 40 MHz, TIMEBASE should be set to at least 0x27 (39) to produce the minimum 1 μ s interval. When transitioning from a powered-down state, the IADC will use five TIMEBASE intervals. When in standby the IADC will use one TIMEBASE interval.

The WARMUPMODE field in the IADC_CTRL register defines whether the IADC is powered down between conversions (WARMUPMODE = NORMAL), in standby between conversions (WARMUPMODE = KEEPINSTANDBY), or remains powered up (WARMUPMODE = KEEPWARM). The resulting start-up time is shown in [Figure 23.3 Start-up Timing on page 751](#). Note that even in WARMUPMODE = KEEPWARM or KEEPINSTANDBY, the ADC will implement 5 TIMEBASE intervals of warmup on initial power up, or any configuration change affecting PRESCALE, ADCMODE, or REFSEL. IADC_STATUS_ADCWARM reflects the current warmup status of the IADC.

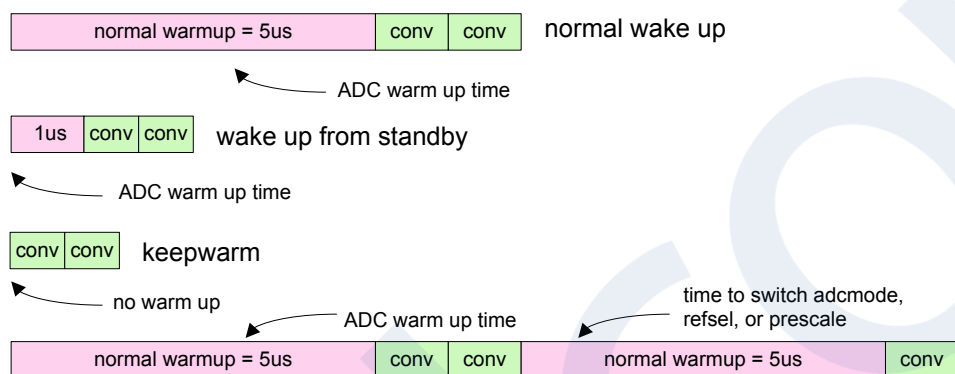

Each change in ADCMODE, REFSEL, or PRESCALE require a 5 μ s warm up period

Figure 23.3. Start-up Timing

23.3.3.2 Conversion Pipeline in Normal and High-Speed Modes

The IADC uses a pipelined architecture to perform different stages of the ADC conversion in parallel.

In Normal and High-Speed modes, the conversion time for a single sample can be determined from the OSR and the pre-scaled ADC_CLK frequency (f_{ADC_CLK}) as:

$$\text{Conversion Time} = ((4 * \text{OSR}) + 2) / f_{ADC_CLK}$$

The minimum OSR is 2, meaning that the fastest possible conversion lasts 10 ADC_CLK clock cycles.

In Normal or High Speed mode, the IADC will automatically insert 2 additional cycles in the pipeline when changing channels to a new input. This allows for hold timing on the previous conversion and allows for time to tristate the ABUS analog buses before connecting the next input to the analog bus. Therefore the maximum sampling rate while continuously sampling on one channel in Normal mode (with ADC_CLK = 10 MHz) is 1 Msps, and the maximum sampling rate while switching channels is 833 ksps.

In High-Speed mode the allowed ADC_CLK speed is doubled to 20 MHz. The maximum sampling rate while continuously converting a single channel is 2 Msps, and the maximum sampling rate while switching channels is 1.67 Msps.

Figure 23.4 Normal Mode ADC Pipeline on page 752 and Figure 23.5 High-Speed Mode ADC Pipeline on page 753 show both single-channel and channel-switching scenarios powering up from a shutdown state with WARMUPMODE = NORMAL. The 5 us warm-up is shown in pink, a first conversion pipeline in green, and a second conversion in orange. The blue area in the top diagram represents the extra time to tristate while changing channels.

Normal mode switching channel between conversions

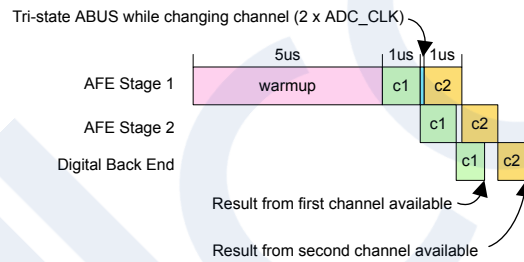

Normal mode converting same channel twice

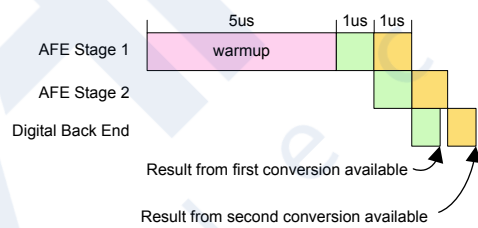
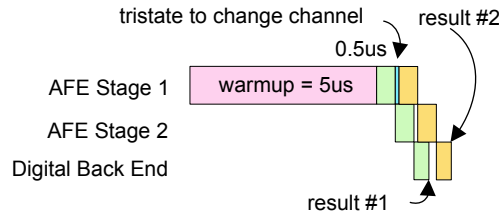

Figure 23.4. Normal Mode ADC Pipeline

High speed mode switching channel between conversions



High speed mode with same channel between conversions

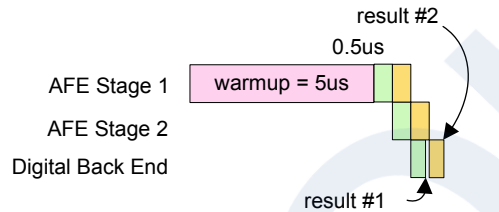

Figure 23.5. High-Speed Mode ADC Pipeline

23.3.3.3 Conversion Pipeline in High-Accuracy Mode

In High-Accuracy mode, the conversion time for a single sample can be determined from the OSR and the pre-scaled ADC_CLK frequency (f_{ADC_CLK}) as:

$$\text{Conversion Time} = ((5 * \text{OSR}) + 7) / f_{ADC_CLK}$$

The minimum OSR is 16, meaning that the fastest possible conversion in High-Accuracy mode lasts 87 ADC_CLK clock cycles.

In High-Accuracy mode, there are no additional cycles required to change channels to a new input. [Figure 23.6 High-Accuracy Mode ADC Pipeline on page 753](#) shows the pipeline timing when powering up from a shutdown state with WARMUPMODE = NORMAL. The 5 us warmup is shown in pink, a first conversion pipeline in green, and a second conversion in orange.

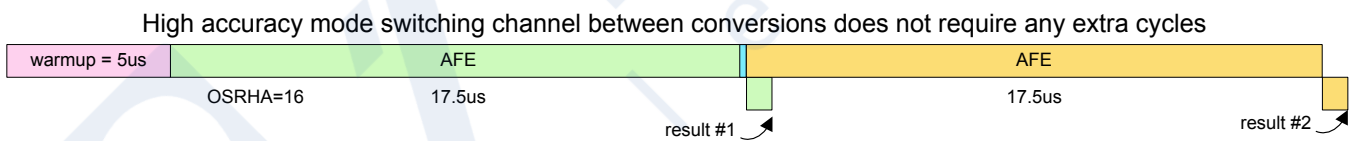

Figure 23.6. High-Accuracy Mode ADC Pipeline

23.3.3.4 Scheduling and Triggers

The IADC has several triggering options available for both the Single queue and the Scan queue. When a conversion trigger occurs and there are no other conversions active or pending, the request is serviced immediately. If both the single and scan queues are being used in an application, it is possible to serve the conversion requests as needed, and specify their priority.

Conversion triggering is configured using bit fields in the IADC_TRIGGER register. The SINGLETRIGSEL and SCANTRIGSEL fields specify the trigger source for Single and Scan conversion queues, respectively. The options for trigger source are:

- IMMEDIATE - Trigger from software. This is useful for triggering conversions on-demand from software with no specific sampling frequency requirements, or initiating continuous conversions at full speed.
- TIMER - Use the IADC local timer to trigger conversions. This is useful for triggering conversions at precise intervals.
- PRSCLKGRP - Use a synchronous PRS channel to trigger from an external peripheral in the same clock group domain (i.e. clock group A). This is useful for synchronizing conversions precisely with external TIMER events or PWM outputs.

Note: It is recommended to configure the PRS consumer registers prior to enabling synchronous PRS triggers to avoid false triggers.

- PRSPOS - Use a positive edge of an asynchronous PRS channel to trigger conversions. The trigger source will require 1-2 CLK_SRC_ADC cycles to synchronize. This is useful for triggering conversions as needed from asynchronous peripheral sources such as GPIO inputs, SYSRTC events, etc.
- PRSNEG - Use a negative edge of an asynchronous PRS channel to trigger conversions. This is the same as PRSPOS, but operates on negative edges of the selected input.

Both the single and scan trigger sources can be configured to generate one request per trigger, or begin continuous conversions. Setting SINGLETRIGACTION to ONCE will make one conversion request each time the selected single trigger occurs, and a single ADC output will be converted. Setting SINGLETRIGACTION to CONTINUOUS allows the single trigger to begin the first conversion, and when a conversion completes a new one will be requested immediately without requiring a new trigger. Channel selections and configuration should not be changed while SINGLETRIGACTION is set to CONTINUOUS. Doing so can produce conversion errors. The scan queue should be used if channel or configuration switching is required.

The SCANTRIGACTION field works to request conversion scans in a similar manner. Setting SCANTRIGACTION to ONCE will make one request each time the selected scan trigger occurs, and the IADC will perform all conversions specified in the scan once before stopping. Setting SCANTRIGACTION to CONTINUOUS allows the scan trigger to initiate continuous scans. When a scan cycle completes, a new one will be requested immediately without requiring a new trigger.

Conversion priority can be adjusted using the SINGLETAILGATE bit. By default, SINGLETAILGATE is set to TAILGATEOFF, meaning that conversion triggers are queued in the order they are received. Any conversion trigger for the Single queue or the Scan queue will initiate a conversion as soon as possible. If any conversion is already in progress or pending, the new conversion will be handled after the current operation.

Setting SINGLETAILGATE to TAILGATEON gives ultimate priority to the Scan queue. The IADC will only perform single conversions immediately after completion of a scan. This allows systems to use the scan queue for high-priority conversions with tight timing requirements, and the single queue for low-priority, on-demand conversion events. Note that this setting should only be used when scan conversions are guaranteed to trigger. If no scan sequence is triggered, any single conversion trigger will remain pending indefinitely. It is also important to note that if there is not enough time between scan conversions to service a single conversion, the next scan conversion will be delayed.

23.3.3.4.1 Conversion Triggering Examples

Scheduling a Single Sample

The simplest use case for the IADC is performing one conversion on-demand from the Single queue. [Figure 23.7 Immediate Single Conversion on page 755](#) shows the configuration and timing of this use case. The IADC warmup mode is configured for normal (shuts down between conversions). The single queue trigger is configured for immediate triggering of one conversion, and tailgating is turned off. When the conversion is requested (by setting IADC_CMD_SINGLESTART), the IADC block warms up and then begins converting. During the conversion, the CONVERTING bit in IADC_STATUS is set. When the conversion is complete, the queue is disabled, and SINGLEQEN returns low.

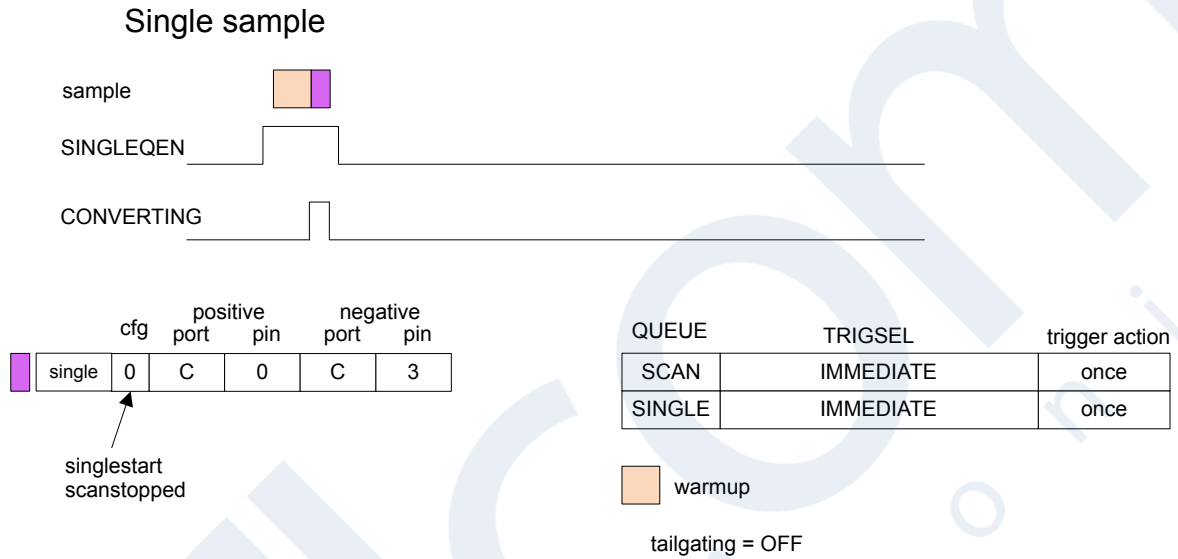

Figure 23.7. Immediate Single Conversion

Periodic Scans

Another common use case is to periodically trigger the IADC to perform a multi-channel scan. [Figure 23.8 Periodic Scan Example on page 756](#) shows the timing of a periodic scan triggered by the IADC's local timer. The scanner is configured to sample four different channels; two using configuration 0 and two using configuration 1. Note that a single TIMER trigger is used to initiate each scan, and all four samples are taken for each trigger. Note also that the IADC inserts another warmup time between conversions 1 and 2, when it switches from configuration 0 to configuration 1. The single queue is disabled and not used in this example.

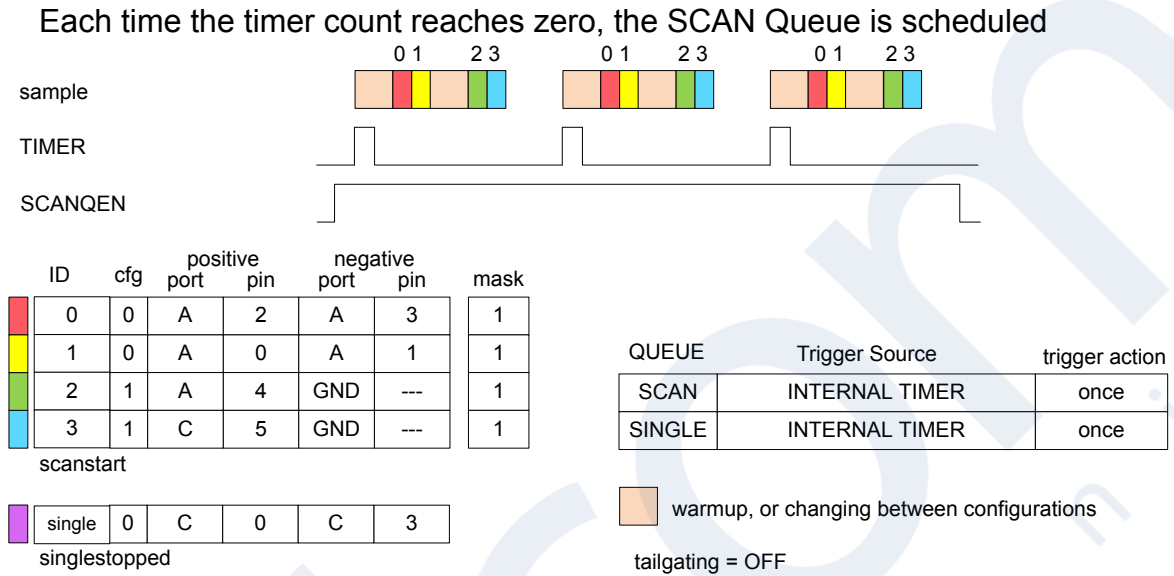

Figure 23.8. Periodic Scan Example

Tailgating Examples

An example using conversion tailgating is shown in [Figure 23.9 Simple Conversion with Tailgating Enabled on page 757](#). In the example, the Scan queue is configured to trigger a two-channel conversion periodically on the IADC local timer, while the Single queue is configured to trigger on-demand from software. When a single conversion is requested, it waits until after the scan sequence is complete, and then the single conversion is performed. The scan conversions are using configuration 0, and the single conversion is using configuration 1, so a warmup delay is inserted between the end of the scan and the beginning of the single conversion cycle. Note that this example provides plenty of time between IADC scan conversions for the single conversion to occur, and no scan conversions are delayed.

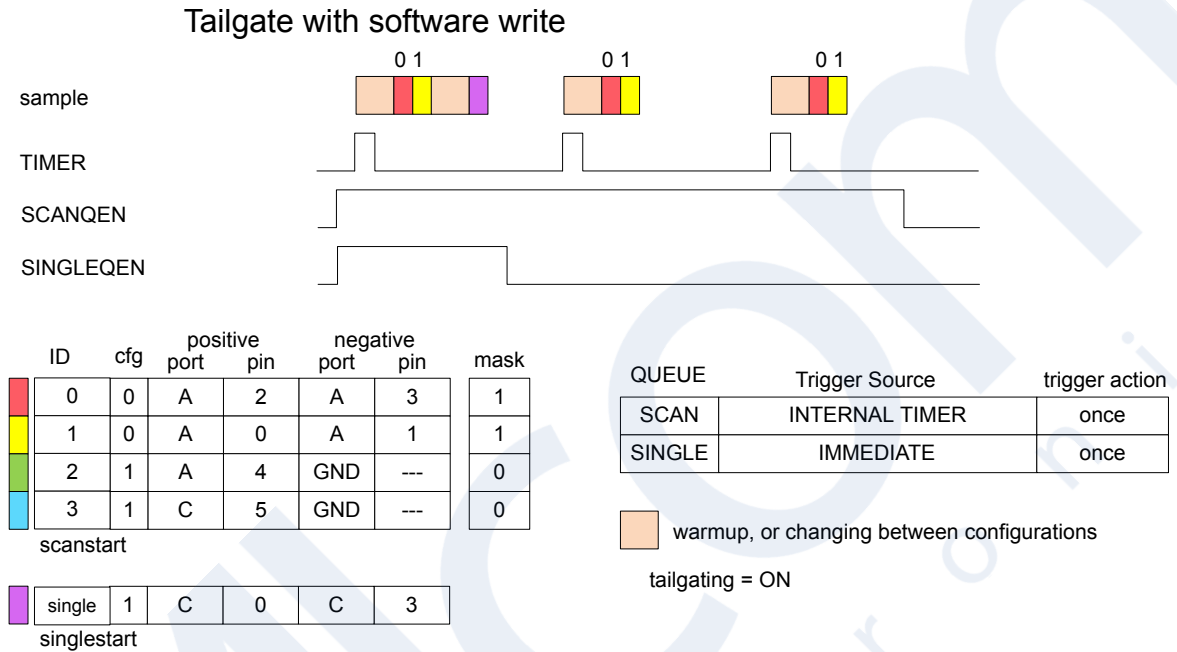

Figure 23.9. Simple Conversion with Tailgating Enabled

Another example, shown in [Figure 23.10 Conversions with Tailgating Disabled on page 758](#), demonstrates how requests are handled on the different conversion queues with tailgating disabled.

In this example, the scan queue is being triggered on the internal timer while the single queue is being triggered on a PRS positive edge. Since tailgating is not enabled, the queues will be serviced on a first come first served basis. The first single queue trigger falls between two scan queue triggers and does not interfere with scan queue timing. The second single queue trigger happens just before the scan queue trigger. The IADC will complete this single queue conversion and delay the next scan queue conversions.

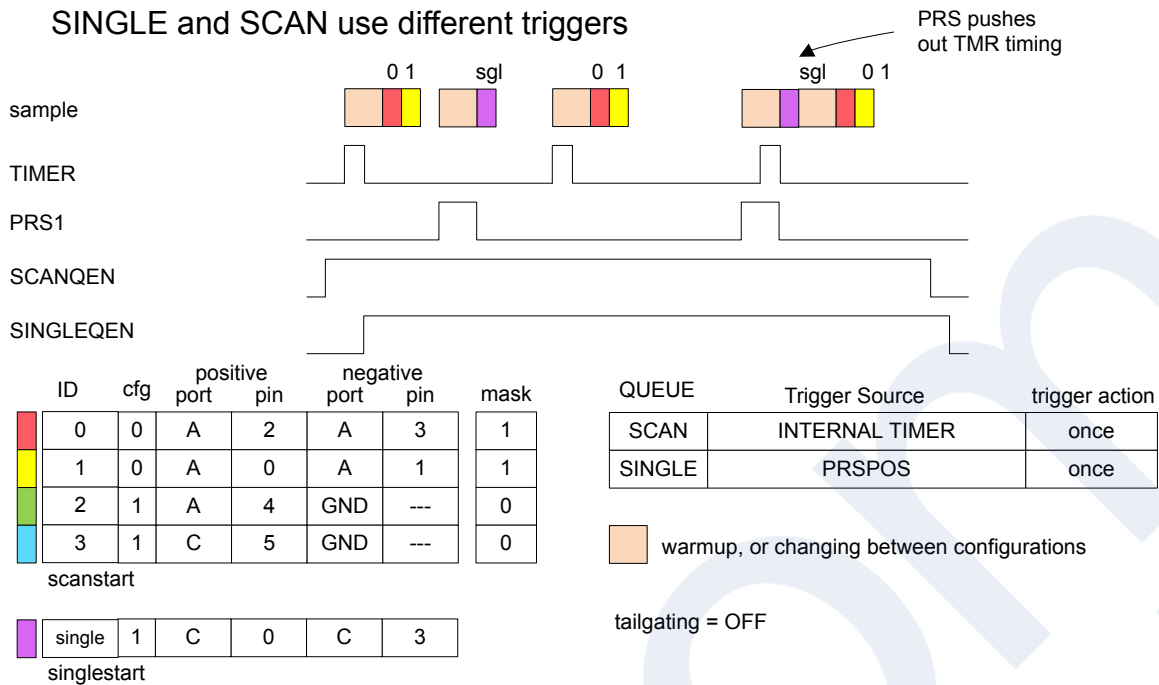

Figure 23.10. Conversions with Tailgating Disabled

Continuous Conversions

An example of continuous conversions triggered from the scan queue is shown in [Figure 23.11 Continuous Conversions on page 758](#). In this example the SCANTRIGACTION field in IADC_TRIGGER is set to CONTINUOUS, and the conversion trigger source is software (SCANTRIGSEL = IMMEDIATE). When the scan queue is enabled with IADC_CMD_SCANSTART, the ADC warms up and then performs repeated back-to-back scans until software disables the scan queue using IADC_CMD_SCANSTOP. While this example shows only one channel converted continuously, it is possible to enable multiple channels for the scan sequence.

Continuous

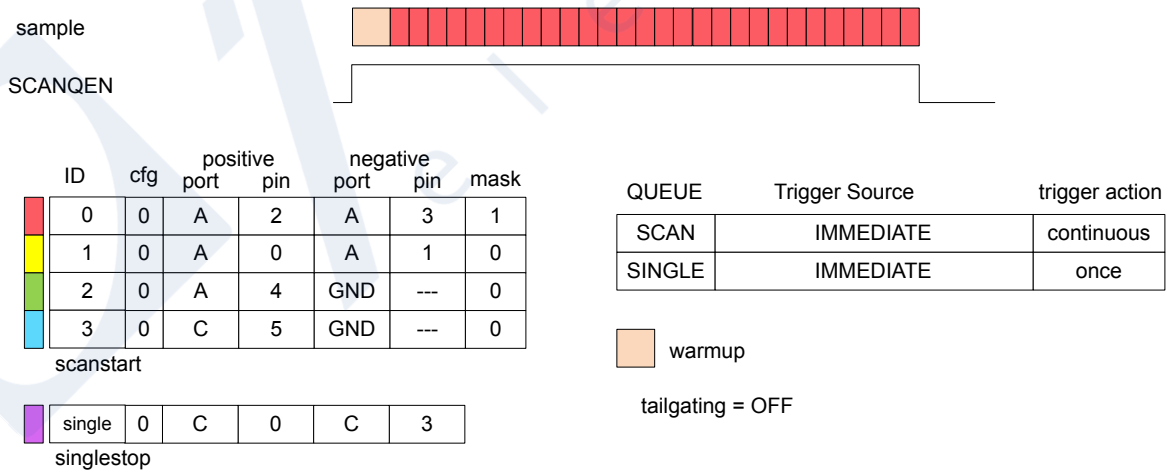

Figure 23.11. Continuous Conversions

23.3.4 Reference Selection and Analog Gain

The default IADC reference is to use the internal band gap circuit. The analog power supply voltage can also be used as a voltage reference. The reference voltage is selected using the REFSEL field in IADC_CFGx.

Table 23.2. Mode Settings

Reference	Description	Normal and High-Speed Mode Voltage Range	High-Accuracy Mode Voltage Range
VBGR	Internal	1.21V	1.21V
VDDX	Analog Power Supply	AVDD	AVDD
VREF	External	1.0V - AVDD (1.25V Nominal)	1.0V - 1.25V (1.25V Nominal)
VREF2P5	External	1.0V - AVDD (1.25V Nominal)	1.0V - 2.5V (2.5V Nominal)

Note:

- In high-accuracy mode with VREF2P5 selected, the AVDD supply must be at least 3V.

The IADC also has analog gain selection, controlled via the ANALOGGAIN field in IADC_CFGx. The analog gain can be set to 0.5x, 1x, 2x, 3x, or 4x. Note that 2x, 3x, and 4x gain modes may require slower ADC_CLK. The analog gain impacts where the full-scale input reading occurs. For example, with a 1.25 V external reference and ANALOGGAIN set to 2x, the analog input to the IADC is multiplied by a factor of 2, and a full-scale reading occurs at $1.25 \text{ V} / 2 = 0.625 \text{ V}$. If ANALOGGAIN is set to 0.5x, the full-scale reading of the ADC will not occur until the input reaches 2.5 V. Note that the ADC is only capable of measuring inputs within the supply rails of the device. If the full scale is configured to be greater than the supply voltage, the maximum input will be limited to the supply.

The sampling capacitance (C_{sample}) is changed according to the analog gain setting.

Table 23.3. Input Sampling Capacitance vs. Analog Gain

Analog Gain Setting	Input Sampling Capacitance
0.5x	1 pF
1x	2 pF
2x	4 pF
3x	6 pF
4x	8 pF

Given the sampling capacitance and the front-end sampling rate (F_{sample}), the input impedance of the converter can be calculated as:

$$Z_{\text{in}} = 1 / (C_{\text{sample}} * F_{\text{sample}})$$

Note that the input is not sampled when the converter is inactive between conversions and operating with WARMUPMODE = NORMAL or KEEPINSTANDBY with longer intervals between conversion triggers can increase the effective input impedance of the converter.

23.3.5 Input and Configuration Selection

The IADC supports measurement on a number of internal and external signals. External signals are routed to GPIO through shared ABUS resources on the device, or (on some devices) through dedicated analog inputs available to the IADC block.

The single queue and the scan queue have separate registers available to select inputs and configurations. The IADC_SINGLE register is used to select the input and configuration for the single queue. The IADC_SCANx registers are used to select the inputs and configurations for each of the scan table entries. In both cases, the register contents and setup are similar. The PORTPOS and PINPOS fields are used to select a signal for the positive ADC input, while PORTNEG and PINNEG are used to select a signal for the negative ADC input. The CFG field selects which of the two configuration sets will be used with the input (i.e. configuration options specified in IADC_CFGx, IADC_SCALEx, and IADC_SCHEx).

To perform single-ended conversions, the PORTNEG field should be set to GND. This indicates that the positive ADC input will be measured with reference to chip ground. PORTPOS and PINPOS should be used to select the desired input signal. The PINNEG field is not used for single-ended conversions.

To perform differential conversions, PORTPOS, PINPOS are used to select the positive input to the ADC, while PORTNEG and PINNEG are used to select the negative input. Note that there are two independent multiplexers in the ADC, and firmware cannot select two signals from the same multiplexer for a differential measurement. The "even" multiplexer consists of all EVEN ABUS selections, Supply voltage options, and GND. The "odd" multiplexer consists of all ODD ABUS selections and GND. One selection from each multiplexer is allowed on the positive and negative input. More detailed examples may be found in [23.3.5.3 ABUS Input Selection Examples](#).

The scan queue has one additional register, IADC_MASKREQ, to specify which of the 16 possible channel slots will be converted during a scan operation. Each channel in the scan queue is enabled by writing the corresponding bit in the IADC_MASKREQ register to 1. Enabled channels will be converted in sequence from lowest to highest, during a scan. See [23.3.5.4 Scan Queue](#) for more details on using the scan queue.

23.3.5.1 External GPIO Inputs

GPIO input selections are routed through shared ABUS resources. In order for the IADC to use any GPIO as an input, the IADC must be allocated appropriate analog bus resources in the GPIO_ABUSALLOC, GPIO_BBUSALLOC, or GPIO_CDBUSALLOC registers. For example, if IADC0 will be using both odd and even numbered pins on GPIO port PA, then AEVEN0 and AODD0 in GPIO_ABUSALLOC could both be set to IADC0. This gives IADC0 access to these two buses. Generally, bus access is set to specific peripherals at configuration time and left alone - it is not normally required to change the bus allocation on the fly. If the IADC requests a pin from a bus that has not been allocated to the IADC, an error will be generated, the PORTALLOCERRIF in IADC_IF will be set, and any conversion result will be 0. For more details on analog bus structure and capabilities, refer to the GPIO section.

When the appropriate analog buses have been configured to route to the IADC, GPIO selection is a simple matter of programming the desired port and pin into the PORTPOS, PINPOS, PORTNEG, and PINNEG fields. For example, to configure a channel to convert the differential voltage between pins PA5 and PA4, PORTPOS = PORTA, PINPOS = 5, PORTNEG = PORTA, PINNEG = 4. If an invalid selection is made, a polarity error will be generated. More specific examples are described in [23.3.5.3 ABUS Input Selection Examples](#).

23.3.5.2 Internal and Dedicated Inputs

Internal signals and dedicated inputs are not routed through the shared ABUS resources. In general, these resources are selected directly by the settings of PORTPOS and PORTNEG, while the PINPOS and PINNEG fields are not used. When PORTPOS is set to SUPPLY, PINPOS is used to select which of the power supplies is connected. To facilitate power supply measurements using internal reference options, higher voltage supplies are attenuated by a factor of 4.

Table 23.4. Supply Selection (PORTPOS = SUPPLY)

PINPOS	Supply Connection	Voltage at Positive Input
0	AVDD	AVDD / 4
1	IOVDD	IOVDD / 4
2	VSS	VSS
3	VSS	VSS
4	DVDD	DVDD / 4
7	DECOUPLE	DECOUPLE

If an internal signal is selected for PORTPOS or PORTNEG, selecting GND on the opposite input will instruct the converter to perform a single-ended conversion. In the case where PORTPOS = GND, the IADC logic will automatically swap the direct input selected by PORTNEG to the positive input of the ADC. Otherwise, a differential conversion is performed with PORTPOS selecting the positive and PORTNEG selecting the negative input.

23.3.5.3 ABUS Input Selection Examples

When configuring to measure a single-ended signal through the ABUS, the positive input selection should always point to the desired input, and PORTNEG should be programmed to GND.

Correct configuration examples for single-ended conversions are shown in [Figure 23.12 Single-Ended Port/Pin Selection Odd Channel on page 762](#) and [Figure 23.13 Single-Ended Port/Pin Selection Even Channel on page 762](#). Note that the IADC logic will automatically swap the appropriate multiplexer to the positive input of the ADC.

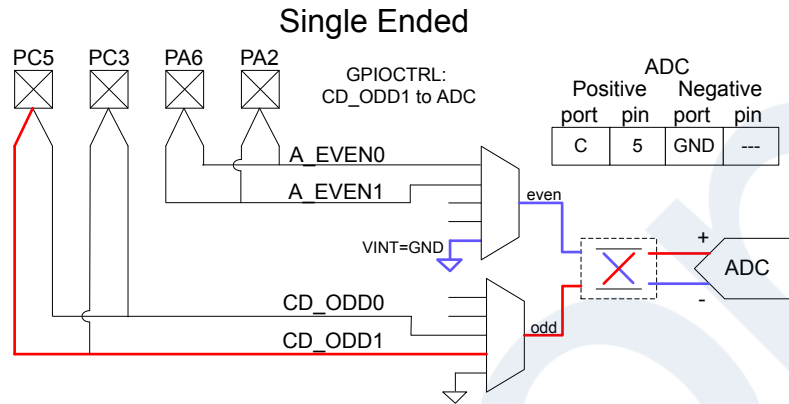

Figure 23.12. Single-Ended Port/Pin Selection Odd Channel

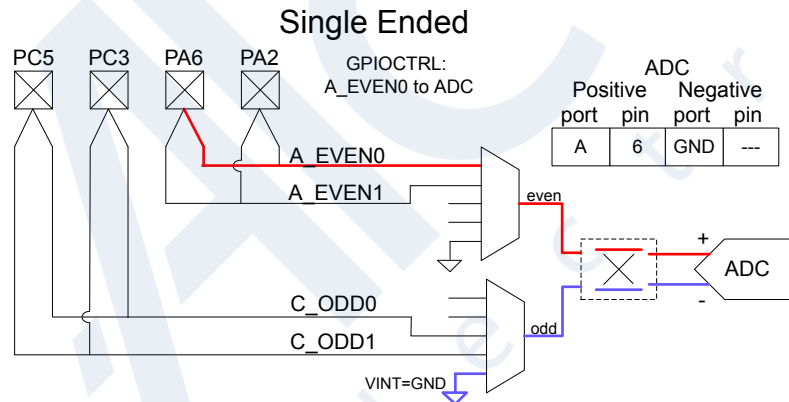

Figure 23.13. Single-Ended Port/Pin Selection Even Channel

[Figure 23.14 Single-Ended Port/Pin Selection Polarity Error on page 763](#) shows an example where the PORTPOS input has been configured to GND, with PORTNEG and PINNEG configured for a GPIO pin. This will result in a polarity error (POLARITYERRIF in IADC_IF will be set) and any conversion result will be 0.

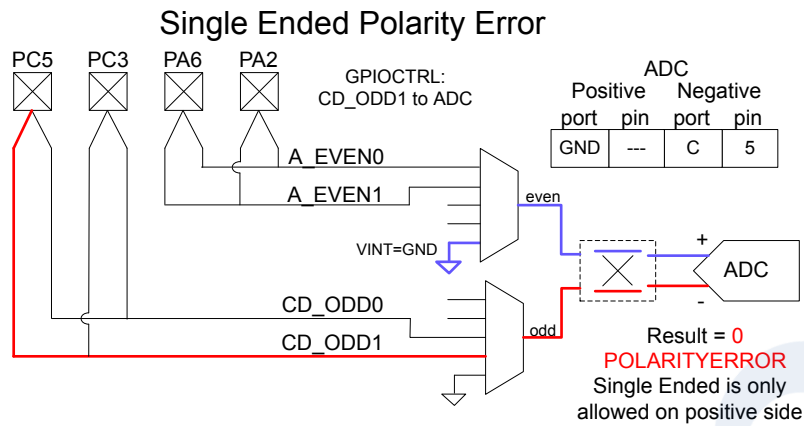

Figure 23.14. Single-Ended Port/Pin Selection Polarity Error

Correct configuration examples for differential conversions are shown in [Figure 23.15 Differential Port/Pin Selection without Swap on page 763](#) and [Figure 23.16 Differential Port/Pin Selection with Swap on page 764](#). In both these examples, the inputs were selected from one EVEN multiplexer channel and one ODD multiplexer channel. As with single-ended mode, the IADC logic will automatically swap the multiplexer connections to the IADC input if needed.

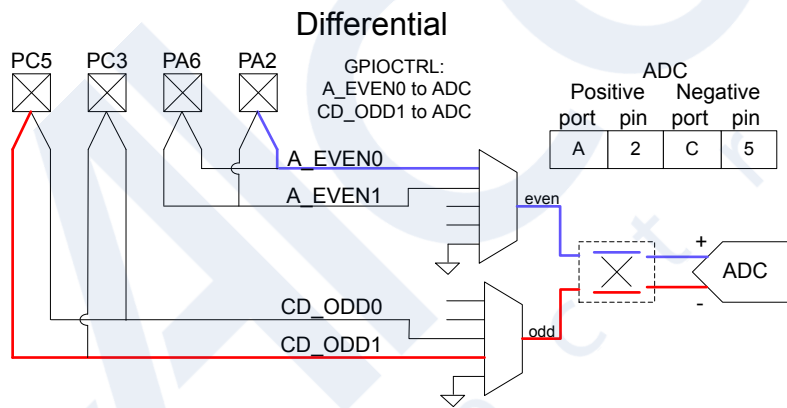

Figure 23.15. Differential Port/Pin Selection without Swap

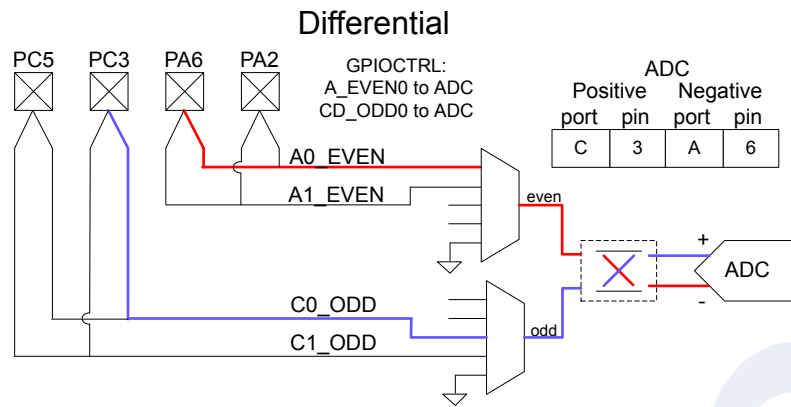

Figure 23.16. Differential Port/Pin Selection with Swap

Figure 23.17 Differential Port/Pin Selection Polarity Error on page 764 shows an example where the both the positive and the negative input selections point to ODD buses. Even though the IADC has been allocated both buses, they both route through the ODD input multiplexer and cannot be measured against one another. This will result in a polarity error (POLARITYERRIF in IADC_IF will be set) and any conversion result will be 0x7FFFF. Likewise, a polarity error will occur if both inputs are selected from EVEN buses.

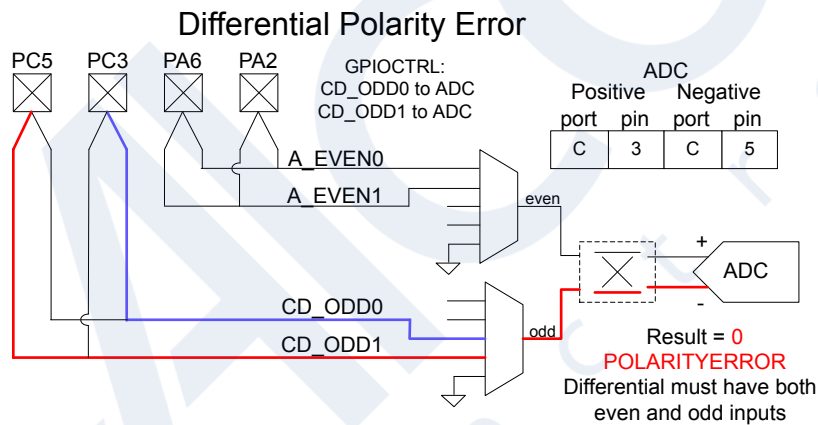

Figure 23.17. Differential Port/Pin Selection Polarity Error

23.3.5.4 Scan Queue

The scan queue allows the IADC to automatically convert up to 16 channels in sequence without CPU intervention. Input and configuration selection for each channel in the scan table is specified by the IADC_SCANx register for that channel (channel 0 is configured with IADC_SCAN0, channel 1 is configured with IADC_SCAN1, and so on). The IADC_MASKREQ register allows software to define which of the scan table entries (IADC_SCANx) to convert during a scan. For example, channels 0, 1, and 7 can be enabled by writing bits 0, 1, and 7 of IADC_MASKREQ to 1 (IADC_MASKREQ = 0x0083).

The IADC_SCANx registers must be configured when the IADC module is disabled (IADC_EN_EN = 0). IADC_MASKREQ can be written while IADC_EN_EN is set to 1. If a scan operation is in progress, MASKREQ will be synchronized and held until the current scan operation has completed. Then MASKREQ is copied into the STMASK register for the next scan operation. IADC_STMASK is the working copy of the MASKREQ used by the IADC during a scan. MASKREQ will only transfer to STMASK when the scan queue is not scanning and converting the scan table. IADC_STATUS_MASKWRITEPENDING can be used by software to see when the MASKREQ write has been transferred to STMASK. Writing a new MASKREQ in the middle of a scan will not corrupt the current scan. Software which writes to MASKREQ during a scan operation must ensure IADC_STATUS_MASKWRITEPENDING returns to 0 before updating IADC_MASKREQ again. Figure 23.18 MASKREQ Updates on page 765 shows a time line of when the MASKREQ write is updated.

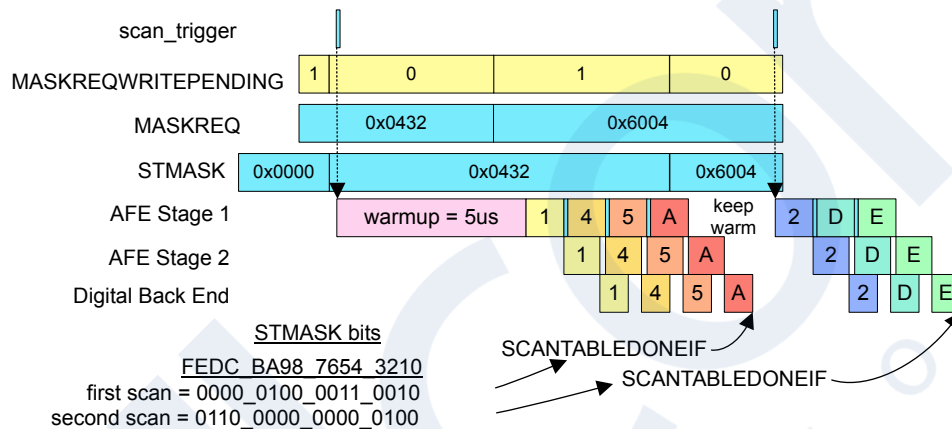

Figure 23.18. MASKREQ Updates

23.3.6 Gain and Offset Correction

The IADC has built in gain and offset correction capabilities. Each of the two configuration groups contains its own correction values stored in the IADC_SCALEx register, allowing the IADC to automatically apply the appropriate correction for the IADC configuration that is being used.

Gain correction is performed through a fixed-point 16-bit value with a range from 0.75x to 1.2499x. The 3 MSBs of the gain value are not directly writeable. The GAIN3MSB bit in IADC_SCALEx is used to select between 011 and 100 for the 3 MSBs, and the lower 13 bits are programmed directly into IADC_SCALEx_GAIN13LSB. Clearing GAIN3MSB to 0 selects the most significant bits of the gain as 011, representing a range from 0.75x to 0.9999x. Setting GAIN3MSB to 1 selects the most significant bits of the gain as 100, representing a range from 1.00x to 1.2499x.

Offset correction is controlled by the OFFSET field in IADC_SCALEx. It is important to note that the offset correction does not have a direct 1-to-1 relationship with the LSB of the IADC output, and depends on both the OSR and gain correction settings. The offset correction range is +/- 12.5% of full scale. OFFSET is encoded as a 2's complement, 18-bit number with the LSB representing 1 / 2²⁰ of full scale. Thus, bit 8 of OFFSET aligns with bit 0 of the 12-bit IADC output word.

23.3.6.1 Using Production Calibration Parameters

IADC calibration is performed on every device during Silicon Labs production test and production calibration parameters are stored in the flash DI page. The production calibration values are useful for a wide variety of possible IADC configurations, but do not map directly to the offset and gain correction fields in the IADC_SCALEx registers. Software must calculate the actual offset and gain correction values from the factory calibration values.

23.3.6.1.1 Gain Correction

Gain error is measured during production test at various settings of ANALOGGAIN, and stored in the DEVINFO_IADC0GAIN0 and DEVINFO_IADC0GAIN1 locations. The GAINCANA1 field is used for 0.5x and 1x ANALOGGAIN settings, while GAINCANA2, GAINCANA3, and GAINCANA4 are used for ANALOGGAIN settings of 2x, 3x, and 4x, respectively.

The GAINCANAn values are expressed as the full 16-bit fixed-point gain, and must be compressed before writing to the IADC_SCALEx register.

23.3.6.1.1.1 Gain Correction in Normal / High Speed Mode

When the IADC is operated in Normal / High Speed mode, a 1st order filter is employed in the decimation. The nominal gain value in these modes for all OSRHS settings is 1.0, or 0x8000 as expressed in the fixed-point 16-bit format. The IADC gain error is designed to be minimal with the digital gain correction set to 1.0 (GAIN3MSB = 1 and GAIN13LSB = 0). Tighter gain error is achieved by adjusting these values in IADC_SCALEx. Using this gain correction mechanism will result in a slight increase to the DNL of the converter, which is reduced by higher OSR settings.

To apply a factory-calibrated gain:

1. Read the appropriate GAINCANAn field from the DEVINFO locations for the selected ANALOGGAIN.
2. Write the MSB (bit 15) of GAINCANAn to GAIN3MSB in IADC_SCALEx.
3. Write the 13 LSBs (bits 12-0) of GAINCANAn to GAIN13LSB in IADC_SCALEx.

23.3.6.1.1.2 Gain Correction in High Accuracy Mode

When the IADC is operated in High Accuracy mode, a 2nd order filter is employed in the decimation. The nominal gain value of the filter is dependent on the OSRHA setting. The gain value stored in DEVINFO space must be adjusted before applying to the IADC_SCALEx register.

To apply a factory-calibrated gain:

1. Read the appropriate GAINCANAn field from the DEVINFO locations for the selected ANALOGGAIN.
2. Multiply the value by the OSR gain correction factor (ha_gain) found in [Table 23.5 Ideal High Accuracy Gain Correction on page 766](#).
3. Write the MSB (bit 15) of the result to GAIN3MSB in IADC_SCALEx.
4. Write the 13 LSBs (bits 12-0) of the result to GAIN13LSB in IADC_SCALEx.

Table 23.5. Ideal High Accuracy Gain Correction

OSRHA Setting	OSR	16-bit OSR Gain Correction (ha_gain)
HIACC16	16 x	0x7879
HIACC32	32 x	0x7C1F
HIACC64	64 x	0x7E08
HIACC92	92 x	0x7A8E
HIACC128	128 x	0x7F02
HIACC256	256 x	0x7F80

23.3.6.1.2 Offset Correction

Offset is impacted by the selected ANALOGGAIN and OSR settings in IADC_CFGx, the GAIN3MSB and GAIN13LSB values in IADC_SCALEx, and the voltage reference. Offset is production calibrated for any combination of possibilities, but the OFFSET register value must be calculated for the given situation before it can be effectively used.

23.3.6.1.2.1 Offset Correction in Normal Mode

The production offset calibration consists of four 16-bit terms written to the DEVINFO space: OFFSETANA1NORM, OFFSETANA2NORM, OFFSETANA3NORM, and OFFSETANABASE. The following procedures will determine the setting for the OFFSET register based on production calibration values.

Step 1: Determine the offset gain adjustment term (off_gain) based on ANALOGGAIN.

For ANALOGGAIN set to 0.5x or 1x:

$$off_gain = 0$$

For ANALOGGAIN set to 2x, 3x, or 4x, off_gain is calculated as:

$$off_gain = OFFSETANA2NORM * (gain - 1)$$

The following table summarizes these equations:

Table 23.6. Offset Gain Adjustment

ANALOGGAIN Setting	Analog front-end gain	Offset Gain Adjustment Term (off_gain)
ANAGAIN0P5	0.5 x	0
ANAGAIN1	1 x	0
ANAGAIN2	2 x	OFFSETANA2NORM * 1
ANAGAIN3	3 x	OFFSETANA2NORM * 2
ANAGAIN4	4 x	OFFSETANA2NORM * 3

Step 2: Calculate the analog offset adjustment term (off_ana) based on OSR and off_gain .

For an OSR of 2x (OSRHS = 0):

$$off_ana = OFFSETANA1NORM + off_gain$$

For all other OSR settings, 4x - 64x:

$$off_ana = OFFSETANABASE + 2 * (OFFSETANA3NORM - off_gain) / OSR$$

The following table expresses these equations:

Table 23.7. Analog Offset Adjustment

OSRHS Setting	OSR	Analog Offset Adjustment Term (off_ana)
HISPD2	2 x	OFFSETANA1NORM + off_gain
HISPD4	4 x	OFFSETANABASE + (OFFSETANA3NORM - off_gain)/2
HISPD8	8 x	OFFSETANABASE + (OFFSETANA3NORM - off_gain)/4
HISPD16	16 x	OFFSETANABASE + (OFFSETANA3NORM - off_gain)/8
HISPD32	32 x	OFFSETANABASE + (OFFSETANA3NORM - off_gain)/16
HISPD64	64 x	OFFSETANABASE + (OFFSETANA3NORM - off_gain)/32

Step 3: Compensate for reference voltage differences.

The off_ana term represents the offset at the input of the ADC, meaning that the reference voltage will have an impact on the magnitude of the offset at the output. Production calibration values are determined with a 1.25 V reference source. If a voltage significantly different than 1.25 V is used for V_{REF} , adjust the off_ana term by a factor of $1.25 / V_{REF}$.

$$off_ana = off_ana * (1.25 / V_{REF})$$

Step 4: Calculate total offset by adding the analog offset to the systematic offset.

Systematic offset is a fixed number dependent on OSR, and calculated according to the following equation:

$$\text{off_sys} = 640 * (256 / \text{OSR})$$

Total uncorrected offset (off_tot) is calculated by:

$$\text{off_tot} = (\text{off_ana} * 4 + \text{off_sys})$$

Step 5: Apply gain error correction, if needed.

Before writing the OFFSET field, the total uncorrected offset must be multiplied by the gain calibration factor. If the gain calibration factor is equal to 1.0 (0x8000 in 16-bit hex, or GAIN3MSB = 1 and GAIN13LSB = 0), this step may be skipped. Otherwise, adjust off_tot according to the following equation:

$$\text{off_tot} = \text{GAIN_FACTOR} * (\text{off_tot} + 0x80000) - 0x80000$$

where $\text{GAIN_FACTOR} = \text{GAINCANAn} / 32768$.

Step 6: Write the offset correction value to the OFFSET field.

The OFFSET field holds an 18-bit 2's complement number, which should be the negation of the total offset, or -(off_tot). Before writing to the SCALE register, any leading sign bits should be masked off to avoid corrupting the programmed gain settings.

$$\text{OFFSET} = 0x3FFFF \& (-\text{off_tot})$$

23.3.6.1.2.2 Offset Correction in High Speed Mode

Offset correction for High Speed mode is identical to the procedure for Normal mode, with the exception of the calibration terms used in the DEVINFO space. The same OFFSETANABASE term is used, but OFFSETANA1HISPD, OFFSETANA2HISPD and OFFSETANA3HISPD are used instead of the OFFSETANAxNORM values. Refer to [23.3.6.1.2.1 Offset Correction in Normal Mode](#) for the procedure, replacing OFFSETANAxNORM with OFFSETANAxHISPD.

23.3.6.1.2.3 Offset Correction in High Accuracy Mode

The production offset calibration for High Accuracy mode uses two 16-bit terms written to the DEVINFO space: OFFSETANA1HIACC and OFFSETANABASE. The following procedure will determine the setting for the OFFSET register based on production calibration values.

Step 1: Calculate the analog offset adjustment term (off_ana) based on the OSR setting (OSRHA in IADC_CFGn).

$$\text{off_ana} = \text{OFFSETANABASE} + \text{OFFSETANA1HIACC} / (2^{\text{OSRHA}})$$

The following table expresses this relationship:

Table 23.8. Analog Offset Adjustment

OSRHA Setting	OSR	Analog Offset Adjustment Term (off_ana)
HIACC16	16 x	OFFSETANABASE + OFFSETANA1HIACC
HIACC32	32 x	OFFSETANABASE + (OFFSETANA1HIACC / 2)
HIACC64	64 x	OFFSETANABASE + (OFFSETANA1HIACC / 4)
HIACC92	92 x	OFFSETANABASE + (OFFSETANA1HIACC / 8)
HIACC128	128 x	OFFSETANABASE + (OFFSETANA1HIACC / 16)
HIACC256	256 x	OFFSETANABASE + (OFFSETANA1HIACC / 32)

Step 2: Compensate for reference voltage differences.

The off_ana term represents the offset at the input of the ADC, meaning that the reference voltage will have an impact on the magnitude of the offset at the output. Production calibration values are determined with a 1.25 V reference source. If a voltage significantly different than 1.25 V is used for V_{REF}, adjust the off_ana term by a factor of 1.25 / V_{REF}.

$$\text{off_ana} = \text{off_ana} * (1.25 / V_{\text{REF}})$$

Step 3: Calculate total offset by adding the analog offset to the systematic offset.

Systematic offset is a fixed number dependent on OSR, and calculated according to the following equation:

$$\text{off_sys} = 0x40000 / (\text{OSR} / (\text{OSR}+1))$$

Total uncorrected offset (off_tot) is calculated by:

$$\text{off_tot} = (\text{off_ana} * 4 + \text{off_sys})$$

Step 4: Apply gain error correction.

Before writing the OFFSET field, the total uncorrected offset must be multiplied by the gain calibration factor according to the following equation:

$$\text{off_tot} = \text{GAIN_FACTOR} * (\text{off_tot} + 0x80000) - 0x80000$$

where GAIN_FACTOR = GAINCANn / 32768.

Step 5: Write the offset correction value to the OFFSET field.

The OFFSET field holds an 18-bit 2's complement number, which should be the negation of the total offset, or -(off_tot). Before writing to the SCALE register, any leading sign bits should be masked off to avoid corrupting the programmed gain settings.

$$\text{OFFSET} = 0x3FFFF \& (-\text{off_tot})$$

23.3.6.2 Calibration

Calibration can be performed in-system to correct for external errors and provide more accurate measurements. The general calibration procedure is as follows:

1. Configure the ADC to the desired mode, OSR, analog gain settings, reference source, etc.
2. Force the IADC to use bipolar output for the conversion: `IADC_CFGx_TWOSCOMPL = FORCEBIPOLAR`.
3. Set the initial offset to the maximum negative value (`IADC_SCALEx_OFFSET = 0x20000`), and the initial gain to 1.0 (`GAIN3MSB = 1`, `GAIN13LSB = 0x0000`). This will prevent output saturation when measuring full scale.
4. Apply a full-scale positive input to the IADC and perform a conversion (*result_fullscale*). Multiple conversions can be performed and averaged together to reduce any system-level noise.
5. Apply a zero input to the IADC and perform a conversion (*result_zero*). Multiple conversions can be performed and averaged together to reduce any system-level noise.
6. Calculate the gain correction factor: Divide the expected value by the difference in the measured values (*result_fullscale* - *result_zero*). Note that the offset adjustment in Step 3 will be canceled out by this calculation.
7. Write the gain correction factor to the IADC using the `GAIN3MSB` and `GAIN13LSB` fields in `IADC_SCALEx`.
8. Set `IADC_SCALEx_OFFSET` to `0x00000` in preparation for the offset calibration.
9. Apply the desired zero voltage to the IADC input and perform a conversion (*result_offset*). Multiple conversions can be performed and averaged together to reduce any system-level noise.
10. Multiply *result_offset* to convert to a 20-bit value (*result_offset_20*). For example, a 12-bit result should be multiplied by 256.
11. Negate *result_offset_20* and write the value to `IADC_SCALEx_OFFSET`.

Note that the `IADC_SCALEx_OFFSET` field is 18 bits. If the result is greater than $(2^{17} - 1)$ or less than (-2^{17}) , the offset is too large to be corrected.

23.3.7 Output Data FIFOs

The single and scan queues each have a eight-word data FIFO. Conversions results are written to the output data FIFO associated with the queue. Single queue results are written to the single FIFO and scan queue results are written to the scan data FIFO. The two queues are identical in operation, but independent.

Conversion results are read from the single FIFO using `IADC_SINGLEFIFODATA`. Reading `SINGLEFIFODATA` will pop the oldest result from the FIFO. It is also possible to read the most recent valid data word using `IADC_SINGLEDATA`. Reading `SINGLEDATA` does not pop a conversion from the FIFO. Similarly, the scan FIFO results are read with `IADC_SCANFIFODATA`, which reads the oldest result and pops the FIFO. The most recent scan result can be read using `IADC_SCANDATA`.

When the single FIFO has valid data, the `SINGLEFIFODV` flag in `IADC_STATUS` is set to 1. When the scan FIFO has valid data `SCANFIFODV` in `IADC_STATUS` is set to 1. These data valid status bits are cleared automatically whenever the associated FIFO is empty. For more granular FIFO status, the number of data words present in the FIFO is indicated in `IADC_SINGLEFIFOSTAT` (for single FIFO) or `IADC_SCANFIFOSTAT` (for scan FIFO).

A programmable data level watermark is also available for the FIFOs, allowing hardware to trigger interrupts or DMA operations when a specified number of conversion results are available. The `DVL` field in register `SINGLEFIFOCFG` or `SCANFIFOCFG` sets the watermark level, between 1 and 4 conversions. If the number of valid entries in the FIFO reaches or exceeds the level set in `DVL`, the `SINGLEFIFODVLIF` (for single FIFO) or `SCANFIFODVLIF` (for scan FIFO) flag in the `IADC_IF` register will be set to 1. If enabled, an interrupt or DMA request will be triggered when the flag is set.

By default, DMA requests are turned off for operation in EM2 or EM3. However, the `DMAWUFIFOSINGLE` or `DMAWUFIFOSCAN` bits in `SINGLEFIFOCFG` or `SCANFIFOCFG` may be used to enable DMA operations in these lower energy modes.

Overflow and underflow status flags are also available in `IADC_IF`. An overflow condition occurs when an IADC conversion completes, but the associated FIFO is already full. In an overflow case the `SINGLEFIFOOVFIF` or `SCANFIFOOVFIF` flag will be set. The most recent conversion will still be available in the `SINGLEDATA` or `SCANDATA` register, but the FIFO will not be updated with the new data. An underflow condition occurs when software or hardware attempts to read from an empty FIFO. In an underflow case the `SINGLEFIFOUFIF` or `SCANFIFOUFIF` flag will be set.

23.3.7.1 Data Alignment and Channel ID

The IADC has data alignment options and the ability to include a channel ID along with the conversion data. For the single queue, alignment and channel ID are configured in the IADC_SINGLEFIFOCFG register. For the scan queue, alignment and channel ID are configured in the IADC_SCANFIFOCFG register.

The ALIGNMENT bit field specifies the data justification and the number of data bits as shown in [Figure 23.19 Data Alignment on page 771](#). By default, the converter will produce 12-bit right-justified data, corresponding to ALIGNMENT = RIGHT12.

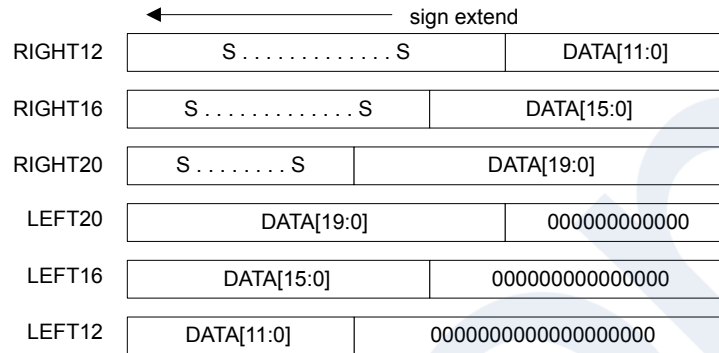
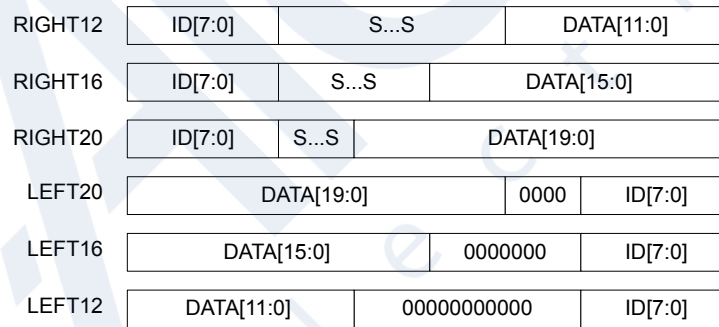

Figure 23.19. Data Alignment

The SHOWID bit controls whether the conversion channel ID is included in the output data word. This option is primarily used with the scan FIFO to help software determine which channel each conversion result came from. If SHOWID is enabled for single conversions, the ID will always be set to 0x20. [Figure 23.20 Data Alignment With ID on page 771](#) shows output data formatting including the ID, when SHOWID = 1.



ID for single queue result is 0x20

Figure 23.20. Data Alignment With ID

23.3.7.2 Output Polarity

The output polarity of the IADC is controlled by the TWOSCOMPL field in the IADC_CFGx register. The IADC supports unipolar and bipolar output formatting independent of the input configuration. By default, the TWOSCOMPL field is set to AUTO, meaning that single-ended conversions will produce unipolar output, and differential conversions will produce bipolar output. The polarity can be forced to unipolar or bipolar mode by setting TWOSCOMPL to FORCEUNIPOLAR or FORCEBIPOLAR, respectively.

Unipolar samples are unsigned integers representing zero to positive full-scale. Bipolar samples are two's-complement signed integers, representing negative full-scale to positive full-scale. Using unipolar mode on a differential input signal allows for more dynamic range when the signal is positive, but will saturate to zero when the signal is negative.

Note: If bipolar output is used with a single-ended input configuration, it is possible to see negative output values when the input is close to ground. However, the input voltage is still limited by the supply range of the device.

23.3.7.3 Digital Accumulation and Averaging

The IADC may optionally accumulate and average several conversion results before posting an output word to the FIFO. Digital averaging is controlled by the DIGAVG field in the IADC_CFGx register. It can be configured to average 1, 2, 4, 8, or 16 samples. The IADC will collect the number of samples specified by DIGAVG on the selected channel slot back-to-back, and produce only one averaged output word.

23.3.7.4 Output Resolution

The usable output resolution of the IADC is a minimum of 12 bits, when the oversampling ratio is set to 2 and no digital averaging is used (DIGAVG = AVG1). An extra bit of output resolution is produced for every power of 2 increase in either of these settings. In other words, the output resolution of the ADC can be determined as:

$$\text{Output Resolution} = 11 + \log_2(\text{OversamplingRatio} \times \text{DigitalAveraging})$$

The MSB is always left-aligned within the DATA field, and the output word will be truncated to 12, 16, or 20 bits, as shown in [Figure 23.19 Data Alignment on page 771](#) and [Figure 23.20 Data Alignment With ID on page 771](#). When using 16 or 20 bit alignment with lower oversampling ratio and digital averaging settings, LSBs of the output can contain residual effects of the offset and gain computation. These residual effects do not represent additional information about the input signal. Any extra LSBs can be masked to 0 by software.

Table 23.9. Output Resolution Masking Examples

Alignment Setting	Oversampling Ratio	Digital Averaging	Number of averaged samples	Output Resolution	Recommended Mask for DATA field
16-bit	2x	1x	2	12 bits	0xFFFF0
16-bit	8x	2x	16	15 bits	0xFFFFE
20-bit	2x	1x	2	12 bits	0xFFF00
20-bit	16x	4x	64	17 bits	0xFFFF8

23.3.7.5 Flushing the FIFOs

Each FIFO has a command bit in the IADC_CMD register that can be used to trigger a FIFO flush. The FIFO data may be flushed independently for each queue. To flush a FIFO:

1. The IADC must be enabled with the clock running.
2. Disable the queue associated with the FIFO using the SCANSTOP or SINGLESTOP bits in the IADC_CMD register.
3. Ensure the queue is disabled by reading the associated flag in the IADC_STATUS register (SINGLEQEN or SCANQEN).
4. Set the command bit to flush the desired FIFO (SINGLEFIFOFLUSH or SCANFIFOFLUSH) in the IADC_CMD register.
5. Wait for the corresponding status bit (SINGLEFIFOFLUSHING or SCANFIFOFLUSHING) in IADC_STATUS to go low.

23.3.8 Window Compare

The IADC has a window comparison unit that can trigger interrupts conditional on the output data of the converter. The window comparison unit has two thresholds - greater than or equal (ADGT), and less than or equal (ADLT), which are programmable through the IADC_CMPTHR register. The ADGT and ADLT thresholds always use a 16 bit, left-justified format, regardless of the format specified by the FIFO. The 12-bit conversion result will be compared against the upper 12 bits of the window comparator.

The window comparison unit is active on the ADC output on a conversion-by-conversion basis, and is shared between the two FIFOs. It is not possible to set different window comparison thresholds for different channels or for each FIFO. However, each channel specified in the IADC has a CMP bit field to enable the window comparison on results from that channel. For example, it is possible to only apply the window comparison and associated interrupt to scan channel #3 by setting the CMP field in IADC_SCAN3 to 1. When the CMP field associated with a channel is 0, the window comparator will not be active for results from that channel.

The window comparator supports conditional triggering on output results which are inside or outside a specified window. When ADLT is greater than or equal to ADGT, the comparator will trigger on an "inside" condition, or when $DATA \leq ADLT$ and $DATA \geq ADGT$. When ADLT is less than ADGT, the comparator will trigger on an "outside" condition, or when $DATA \leq ADLT$ or $DATA \geq ADGT$.

Figure 23.21 Window Comparison Examples on page 773 shows different configurations of the ADLT and ADGT values and the resulting windows. When the window comparator detects that the appropriate conditions are met (shown by the shaded region in the figure), it will generate an interrupt via the SINGLECMPIF flag for conversions on the single queue, or via the SCANCMPIF flag for conversions on the scan queue.

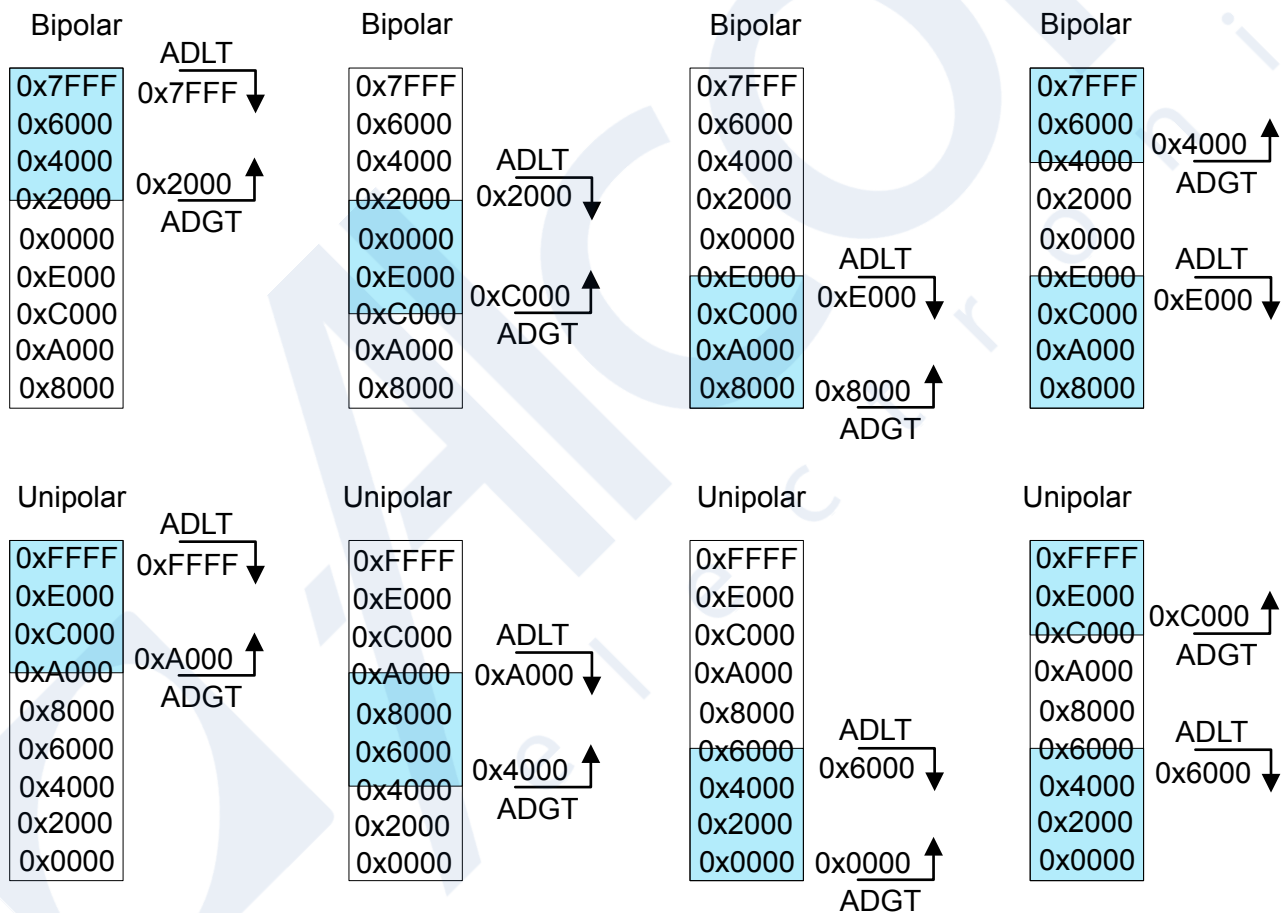

Figure 23.21. Window Comparison Examples

23.3.9 Interrupts

Interrupts are enabled in the IADC_IEN register, allowing interrupts to be generated on several different IADC conditions. Each of the flags in IADC_IF has a corresponding enable bit in the IADC_IEN register. A brief overview of the available interrupt sources is shown in the list below; more details can be found in the relevant sections of this chapter.

- SINGLEFIFODVLIF - The single FIFO watermark specified in SINGLEFIFOCFG_DVL has been reached or exceeded.
- SCANFIFODVLIF - The scan FIFO watermark specified in SCANFIFOCFG_DVL has been reached or exceeded.
- SINGLECMPIF - A conversion result from the single queue tripped the window comparator.
- SCANCMPIF - A conversion result from the scan queue tripped the window comparator.
- SCANENTRYDONEIF - A scan queue conversion has completed.
- SCANTABLEDONEIF - A scan queue operation has completed (all channels specified in the scan mask have been converted once).
- POLARITYERRIF - A channel polarity selection error has occurred (two channels from the EVEN multiplexer or two channels from the ODD multiplexer were selected for positive and negative inputs).
- PORTALLOCERRIF - A port allocation error has occurred (a pin not allocated to the IADC in the GPIO bus allocation registers was requested).
- SINGLEFIFOOFIF - A single FIFO overflow has occurred.
- SCANFIFOOFIF - A scan FIFO overflow has occurred.
- SINGLEFIFOUFIF - A single FIFO underflow has occurred.
- SCANFIFOUFIF - A scan FIFO underflow has occurred.
- EM23ABORTERRORIF - The system entered EM2 or EM3 while the IADC was converting and using a clock not supported in EM2 or EM3.

Hardware sets the interrupt flags in IADC_IF, and the flags remain set (sticky) until cleared by software. The interrupt flags should be cleared before enabling the IADC to remove any previous interrupt history. Clearing or setting interrupt bits can be done by writing to IADC_IF with a set or clear mask.

23.4 IADC Register Map

The offset register address is relative to the registers base address.

Offset	Name	Type	Description
0x000	IADC_IPVERSION	R	IPVERSION
0x004	IADC_EN	RW ENABLE	Enable
0x008	IADC_CTRL	RW CONFIG	Control
0x00C	IADC_CMD	W SYNC	Command
0x010	IADC_TIMER	RW CONFIG	Timer
0x014	IADC_STATUS	RH	Status
0x018	IADC_MASKREQ	RW SYNC	Mask Request
0x01C	IADC_STMASK	RH SYNC	Scan Table Mask
0x020	IADC_CMPTHR	RW CONFIG	Digital Window Comparator Threshold
0x024	IADC_IF	RWH INTFLAG	Interrupt Flags
0x028	IADC_IEN	RW	Interrupt Enable
0x02C	IADC_TRIGGER	RW CONFIG	Trigger
0x048	IADC_CFGx	RW CONFIG	Configuration
0x050	IADC_SCALEx	RW CONFIG	Scaling
0x054	IADC_SCHEx	RW CONFIG	Scheduling
0x070	IADC_SINGLEFIFOCFG	RW CONFIG	Single FIFO Configuration
0x074	IADC_SINGLEFIFODATA	RH(r)	Single FIFO DATA
0x078	IADC_SINGLEFIFOSTAT	RH	Single FIFO Status
0x07C	IADC_SINGLEDATA	RH SYNC	Single Data
0x080	IADC_SCANFIFOCFG	RW CONFIG	Scan FIFO Configuration
0x084	IADC_SCANFIFODATA	RH(r)	Scan FIFO Read Data
0x088	IADC_SCANFIFOSTAT	RH	Scan FIFO Status
0x08C	IADC_SCANDATA	RH SYNC	Scan Data
0x098	IADC_SINGLE	RW SYNC	Single Queue Port Selection
0x0A0	IADC_SCANx	RW CONFIG	SCAN Entry
0x1000	IADC_IPVERSION_SET	R	IPVERSION
0x1004	IADC_EN_SET	RW ENABLE	Enable
0x1008	IADC_CTRL_SET	RW CONFIG	Control
0x100C	IADC_CMD_SET	W SYNC	Command
0x1010	IADC_TIMER_SET	RW CONFIG	Timer
0x1014	IADC_STATUS_SET	RH	Status
0x1018	IADC_MASKREQ_SET	RW SYNC	Mask Request
0x101C	IADC_STMASK_SET	RH SYNC	Scan Table Mask
0x1020	IADC_CMPTHR_SET	RW CONFIG	Digital Window Comparator Threshold
0x1024	IADC_IF_SET	RWH INTFLAG	Interrupt Flags

Offset	Name	Type	Description
0x1028	IADC_IEN_SET	RW	Interrupt Enable
0x102C	IADC_TRIGGER_SET	RW CONFIG	Trigger
0x1048	IADC_CFGx_SET	RW CONFIG	Configuration
0x1050	IADC_SCALEx_SET	RW CONFIG	Scaling
0x1054	IADC_SCHEx_SET	RW CONFIG	Scheduling
0x1070	IADC_SINGLEFIFOCFG_SET	RW CONFIG	Single FIFO Configuration
0x1074	IADC_SINGLEFIFODATA_SET	RH(r)	Single FIFO DATA
0x1078	IADC_SINGLEFIFOSTAT_SET	RH	Single FIFO Status
0x107C	IADC_SINGLEDATA_SET	RH SYNC	Single Data
0x1080	IADC_SCANFIFOCFG_SET	RW CONFIG	Scan FIFO Configuration
0x1084	IADC_SCANFIFODATA_SET	RH(r)	Scan FIFO Read Data
0x1088	IADC_SCANFIFOSTAT_SET	RH	Scan FIFO Status
0x108C	IADC_SCANDATA_SET	RH SYNC	Scan Data
0x1098	IADC_SINGLE_SET	RW SYNC	Single Queue Port Selection
0x10A0	IADC_SCANx_SET	RW CONFIG	SCAN Entry
0x2000	IADC_IPVERSION_CLR	R	IPVERSION
0x2004	IADC_EN_CLR	RW ENABLE	Enable
0x2008	IADC_CTRL_CLR	RW CONFIG	Control
0x200C	IADC_CMD_CLR	W SYNC	Command
0x2010	IADC_TIMER_CLR	RW CONFIG	Timer
0x2014	IADC_STATUS_CLR	RH	Status
0x2018	IADC_MASKREQ_CLR	RW SYNC	Mask Request
0x201C	IADC_STMASK_CLR	RH SYNC	Scan Table Mask
0x2020	IADC_CMPTHR_CLR	RW CONFIG	Digital Window Comparator Threshold
0x2024	IADC_IF_CLR	RWH INTFLAG	Interrupt Flags
0x2028	IADC_IEN_CLR	RW	Interrupt Enable
0x202C	IADC_TRIGGER_CLR	RW CONFIG	Trigger
0x2048	IADC_CFGx_CLR	RW CONFIG	Configuration
0x2050	IADC_SCALEx_CLR	RW CONFIG	Scaling
0x2054	IADC_SCHEx_CLR	RW CONFIG	Scheduling
0x2070	IADC_SINGLEFIFOCFG_CLR	RW CONFIG	Single FIFO Configuration
0x2074	IADC_SINGLEFIFODATA_CLR	RH(r)	Single FIFO DATA
0x2078	IADC_SINGLEFIFOSTAT_CLR	RH	Single FIFO Status
0x207C	IADC_SINGLEDATA_CLR	RH SYNC	Single Data
0x2080	IADC_SCANFIFOCFG_CLR	RW CONFIG	Scan FIFO Configuration
0x2084	IADC_SCANFIFODATA_CLR	RH(r)	Scan FIFO Read Data
0x2088	IADC_SCANFIFOSTAT_CLR	RH	Scan FIFO Status

Offset	Name	Type	Description
0x208C	IADC_SCANDATA_CLR	RH SYNC	Scan Data
0x2098	IADC_SINGLE_CLR	RW SYNC	Single Queue Port Selection
0x20A0	IADC_SCANx_CLR	RW CONFIG	SCAN Entry
0x3000	IADC_IPVERSION_TGL	R	IPVERSION
0x3004	IADC_EN_TGL	RW ENABLE	Enable
0x3008	IADC_CTRL_TGL	RW CONFIG	Control
0x300C	IADC_CMD_TGL	W SYNC	Command
0x3010	IADC_TIMER_TGL	RW CONFIG	Timer
0x3014	IADC_STATUS_TGL	RH	Status
0x3018	IADC_MASKREQ_TGL	RW SYNC	Mask Request
0x301C	IADC_STMASK_TGL	RH SYNC	Scan Table Mask
0x3020	IADC_CMPTHR_TGL	RW CONFIG	Digital Window Comparator Threshold
0x3024	IADC_IF_TGL	RWH INTFLAG	Interrupt Flags
0x3028	IADC_IEN_TGL	RW	Interrupt Enable
0x302C	IADC_TRIGGER_TGL	RW CONFIG	Trigger
0x3048	IADC_CFGx_TGL	RW CONFIG	Configuration
0x3050	IADC_SCALEx_TGL	RW CONFIG	Scaling
0x3054	IADC_SCHEx_TGL	RW CONFIG	Scheduling
0x3070	IADC_SINGLEFIFOCFG_TGL	RW CONFIG	Single FIFO Configuration
0x3074	IADC_SINGLEFIFODATA_TGL	RH(r)	Single FIFO DATA
0x3078	IADC_SINGLEFIFOSTAT_TGL	RH	Single FIFO Status
0x307C	IADC_SINGLEDATA_TGL	RH SYNC	Single Data
0x3080	IADC_SCANFIFOCFG_TGL	RW CONFIG	Scan FIFO Configuration
0x3084	IADC_SCANFIFODATA_TGL	RH(r)	Scan FIFO Read Data
0x3088	IADC_SCANFIFOSTAT_TGL	RH	Scan FIFO Status
0x308C	IADC_SCANDATA_TGL	RH SYNC	Scan Data
0x3098	IADC_SINGLE_TGL	RW SYNC	Single Queue Port Selection
0x30A0	IADC_SCANx_TGL	RW CONFIG	SCAN Entry

23.5 IADC Register Description

23.5.1 IADC_IPVERSION - IPVERSION

Offset	Bit Position																															
0x000	31	30	29	28	27	26	25	24	23	22	21	20	19	18	17	16	15	14	13	12	11	10	9	8	7	6	5	4	3	2	1	0
Reset	0x3																															
Access	R																															
Name	IPVERSION																															

Bit	Name	Reset	Access	Description
31:0	IPVERSION	0x3	R	IP version ID
The read only IPVERSION field gives the version for this module. There may be minor software changes required for modules with different values of IPVERSION.				

23.5.2 IADC_EN - Enable

Offset	Bit Position																															
0x004	31	30	29	28	27	26	25	24	23	22	21	20	19	18	17	16	15	14	13	12	11	10	9	8	7	6	5	4	3	2	1	0
Reset																															0x0	0x0
Access																															R	RW
Name																															DISABLING	EN

Bit	Name	Reset	Access	Description
31:2	<i>Reserved</i>	<i>To ensure compatibility with future devices, always write Reserved bits to their reset value, unless otherwise stated. More information in 1.2 Conventions</i>		
1	DISABLING	0x0	R	Disablement busy status
When EN is cleared, DISABLING status is set immediately, and cleared when disablement finishes. Disablement resets peripheral cores and not APB registers except hardware updated registers such as INTFLAGS and FIFOs.				
0	EN	0x0	RW	Enable IADC Module
The EN bit enables the module. Software should write to CONFIG type registers before setting the EN bit. Software should write to SYNC type registers only after setting the EN bit.				
Value		Mode		Description
0		DISABLE		Disable
1		ENABLE		Enable

23.5.3 IADC_CTRL - Control

Offset	Bit Position																																				
0x008	31	30	29	28	27	26	25	24	23	22	21	20	19	18	17	16	15	14	13	12	11	10	9	8	7	6	5	4	3	2	1	0					
Reset			0x0										0x0															0x0		0x0		0x0		0x0			
Access			RW										RW																RW		RW		RW		RW		
Name			HSCLKRATE										TIMEBASE																WARMUPMODE		DBGHALT		ADCCCLKSUSPEND1		ADCCCLKSUSPEND0		EM23WU_CONVERT

Bit	Name	Reset	Access	Description															
31	<i>Reserved</i>	<i>To ensure compatibility with future devices, always write Reserved bits to their reset value, unless otherwise stated. More information in 1.2 Conventions</i>																	
30:28	HSCLKRATE	0x0	RW	High Speed Clock Rate Ratio to divide incoming CLK_CMU_ADC clock by. The resulting clock (CLK_SRC_ADC) must be 40 MHz or less. <table border="1"> <thead> <tr> <th>Value</th> <th>Mode</th> <th>Description</th> </tr> </thead> <tbody> <tr> <td>0</td> <td>DIV1</td> <td>Use CMU_CLK_ADC directly. The source clock must be 40 MHz or less.</td> </tr> <tr> <td>1</td> <td>DIV2</td> <td>Divide CMU_CLK_ADC by 2 before using it. The resulting CLK_SRC_ADC must be 40 MHz or less.</td> </tr> <tr> <td>2</td> <td>DIV3</td> <td>Divide CMU_CLK_ADC by 3 before using it. The resulting CLK_SRC_ADC must be 40 MHz or less.</td> </tr> <tr> <td>3</td> <td>DIV4</td> <td>Divide CMU_CLK_ADC by 4 before using it. The resulting CLK_SRC_ADC must be 40 MHz or less.</td> </tr> </tbody> </table>	Value	Mode	Description	0	DIV1	Use CMU_CLK_ADC directly. The source clock must be 40 MHz or less.	1	DIV2	Divide CMU_CLK_ADC by 2 before using it. The resulting CLK_SRC_ADC must be 40 MHz or less.	2	DIV3	Divide CMU_CLK_ADC by 3 before using it. The resulting CLK_SRC_ADC must be 40 MHz or less.	3	DIV4	Divide CMU_CLK_ADC by 4 before using it. The resulting CLK_SRC_ADC must be 40 MHz or less.
Value	Mode	Description																	
0	DIV1	Use CMU_CLK_ADC directly. The source clock must be 40 MHz or less.																	
1	DIV2	Divide CMU_CLK_ADC by 2 before using it. The resulting CLK_SRC_ADC must be 40 MHz or less.																	
2	DIV3	Divide CMU_CLK_ADC by 3 before using it. The resulting CLK_SRC_ADC must be 40 MHz or less.																	
3	DIV4	Divide CMU_CLK_ADC by 4 before using it. The resulting CLK_SRC_ADC must be 40 MHz or less.																	
27:23	<i>Reserved</i>	<i>To ensure compatibility with future devices, always write Reserved bits to their reset value, unless otherwise stated. More information in 1.2 Conventions</i>																	
22:16	TIMEBASE	0x0	RW	Time Base ADC clock cycles (TIMEBASE + 1) needed to generate a 1 us interval for warm up and start up timing. Does not allow less than 2 cycles. A setting of 0x0 (1 cycle) is replaced with 0x1 (2 cycles).															
15:6	<i>Reserved</i>	<i>To ensure compatibility with future devices, always write Reserved bits to their reset value, unless otherwise stated. More information in 1.2 Conventions</i>																	
5:4	WARMUPMODE	0x0	RW	Warmup Mode Select the warmup mode for the ADC. <table border="1"> <thead> <tr> <th>Value</th> <th>Mode</th> <th>Description</th> </tr> </thead> <tbody> <tr> <td>0</td> <td>NORMAL</td> <td>Shut down the IADC after conversions have completed.</td> </tr> <tr> <td>1</td> <td>KEEPINSTANDBY</td> <td>Switch to standby mode after conversions have completed. The next warmup time will require 1us.</td> </tr> <tr> <td>2</td> <td>KEEPWARM</td> <td>Keep IADC fully powered after conversions have completed.</td> </tr> </tbody> </table>	Value	Mode	Description	0	NORMAL	Shut down the IADC after conversions have completed.	1	KEEPINSTANDBY	Switch to standby mode after conversions have completed. The next warmup time will require 1us.	2	KEEPWARM	Keep IADC fully powered after conversions have completed.			
Value	Mode	Description																	
0	NORMAL	Shut down the IADC after conversions have completed.																	
1	KEEPINSTANDBY	Switch to standby mode after conversions have completed. The next warmup time will require 1us.																	
2	KEEPWARM	Keep IADC fully powered after conversions have completed.																	
3	DBGHALT	0x0	RW	Debug Halt															

Bit	Name	Reset	Access	Description
	ADC behavior when halted by debugger.			
	Value	Mode		Description
	0	NORMAL		Continue operation as normal during debug mode
	1	HALT		Complete the current conversion and then halt during debug mode
2	ADCCLKSUSPEND1	0x0	RW	ADC_CLK Suspend - PRS1
	This only functions with single trigger select set to PRSPOS or PRSNEG. In EM0 and EM1, this gates the local clock while clock source remains running. In EM2 and EM3, this disables the clock source until the PRSPOS or PRSNEG event is detected. This bit has no effect if the local IADC timer is running.			
	Value	Mode		Description
	0	PRSWUDIS		Normal mode which does not disable the ADC_CLK.
	1	PRSWUEN		ADCCLKWUEN will gate off ADC_CLK until the trigger is detected provided the internal timer is not selected as the trigger. Once the trigger is detected the ADC_CLK will be started, the band gap will be started, the ADC will be warmed up, and the SCAN Table and the Single entry will be converted. Once the conversions are done, the ADC_CLK will be gated off.
1	ADCCLKSUSPEND0	0x0	RW	ADC_CLK Suspend - PRS0
	This only functions with scan trigger select set to PRSPOS or PRSNEG. In EM0 and EM1, this gates the local clock while clock source remains running. In EM2 and EM3, this disables the clock source until the PRSPOS or PRSNEG event is detected. This bit has no effect if the local IADC timer is running.			
	Value	Mode		Description
	0	PRSWUDIS		Normal mode which does not disable the ADC_CLK.
	1	PRSWUEN		ADCCLKWUEN will gate off ADC_CLK until the trigger is detected provided the internal timer is not selected as the trigger. Once the trigger is detected the ADC_CLK will be started, the band gap will be started, the ADC will be warmed up, and the SCAN Table and the Single entry will be converted. Once the conversions are done, the ADC_CLK will be gated off.
0	EM23WUCONVERT	0x0	RW	EM23 Wakeup on Conversion
	EM23 wake up on conversion			
	Value	Mode		Description
	0	WUDVL		When using suspend mode, conversions performed in EM2 or EM3 should not wake up the DMA until the FIFO's DVL setting is reached. This saves more power for large OSR settings or infrequent sampling.
	1	WUCONVERT		When using suspend mode, conversions performed in EM2 or EM3 will wake up the DMA and keep it awake until the conversions are done, regardless of the DVL setting. This mode burns more power, but it is useful when the conversion rate is faster than the time for the DMA to cycle through wake up and going back to sleep as it converts more than 4 scan table entries. Without using the wake up on conversion mode, the FIFO may overflow while the DMA is going in and out of sleep.

23.5.4 IADC_CMD - Command

Offset	Bit Position																															
0x00C	31	30	29	28	27	26	25	24	23	22	21	20	19	18	17	16	15	14	13	12	11	10	9	8	7	6	5	4	3	2	1	0
Reset							0x0	0x0							0x0	0x0											0x0	0x0			0x0	0x0
Access							W(nB)	W(nB)							W(nB)	W(nB)											W(nB)	W(nB)			W(nB)	W(nB)
Name							SCANFIFOFLUSH	SINGLEFIFOFLUSH							TIMERDIS	TIMEREN											SCANSTOP	SCANSTART			SINGLESTOP	SINGLESTART

Bit	Name	Reset	Access	Description
31:26	<i>Reserved</i>	<i>To ensure compatibility with future devices, always write Reserved bits to their reset value, unless otherwise stated. More information in 1.2 Conventions</i>		
25	SCANFIFOFLUSH	0x0	W(nB)	Flush the Scan FIFO Flush the Scan FIFO. The IADC must be enabled, not suspended, and the IADC clock must be running. Operation has completed when STATUS.SCANFIFOFLUSHING has gone low. The scan queue should be disabled. Any incoming scan queue data will be discarded during the flush.
24	SINGLEFIFOFLUSH	0x0	W(nB)	Flush the Single FIFO Flush the Single FIFO. The IADC must be enabled, not suspended, and the IADC clock must be running. Operation has completed when STATUS.SINGLEFIFOFLUSHING has gone low. The Single queue should be disabled. Any incoming single queue data will be discarded during the flush.
23:18	<i>Reserved</i>	<i>To ensure compatibility with future devices, always write Reserved bits to their reset value, unless otherwise stated. More information in 1.2 Conventions</i>		
17	TIMERDIS	0x0	W(nB)	Timer Disable Disable the local timer and reset the counter to timer reload value.
16	TIMEREN	0x0	W(nB)	Timer Enable Enable the local timer.
15:5	<i>Reserved</i>	<i>To ensure compatibility with future devices, always write Reserved bits to their reset value, unless otherwise stated. More information in 1.2 Conventions</i>		
4	SCANSTOP	0x0	W(nB)	Scan Queue Stop Stop the Scan queue. Disables Scan triggers and clears pending conversions in the Scan queue. Any conversion that has already started will continue until it is complete. If the scan queue is stopped before all entries of the scan table have completed, the remaining entries will not be converted.
3	SCANSTART	0x0	W(nB)	Scan Queue Start Start the Scan queue. Enables triggering of the Scan queue.
2	<i>Reserved</i>	<i>To ensure compatibility with future devices, always write Reserved bits to their reset value, unless otherwise stated. More information in 1.2 Conventions</i>		
1	SINGLESTOP	0x0	W(nB)	Single Queue Stop Stop the Single queue. Disables Single queue triggers and clears pending conversions in the Single queue. Any conversion that has already started will continue until it is complete.
0	SINGLESTART	0x0	W(nB)	Single Queue Start

Bit	Name	Reset	Access	Description
				Start the Single queue. Enables triggering of the Single queue.

23.5.5 IADC_TIMER - Timer

Offset	Bit Position																															
0x010	31	30	29	28	27	26	25	24	23	22	21	20	19	18	17	16	15	14	13	12	11	10	9	8	7	6	5	4	3	2	1	0
Reset																																
Access																																
Name																	TIMER															
																	RW 0x0															

Bit	Name	Reset	Access	Description
31:16	<i>Reserved</i>	<i>To ensure compatibility with future devices, always write Reserved bits to their reset value, unless otherwise stated. More information in 1.2 Conventions</i>		
15:0	TIMER	0x0	RW	Timer Period Number of CLK_SRC_ADC cycles per timer event.

23.5.6 IADC_STATUS - Status

Offset	Bit Position																															
0x014	31	30	29	28	27	26	25	24	23	22	21	20	19	18	17	16	15	14	13	12	11	10	9	8	7	6	5	4	3	2	1	0
Reset		0x0						0x0			0x0	0x0				0x0	0x0	0x0					0x0	0x0		0x0		0x0	0x0		0x0	0x0
Access		R						R			R	R				R	R	R					R	R		R		R	R		R	R
Name		ADCWARM						SYNCBUSY			MASKREQWRITEPENDING	SINGLEWRITEPENDING				TIMERACTIVE	SCANFIFOFLUSHING	SINGLEFIFOFLUSHING					SCANFIFODV	SINGLEFIFODV		CONVERTING		SCANQUEUEPENDING	SCANQEN		SINGLEQUEUEPENDING	SINGLEQEN

Bit	Name	Reset	Access	Description
31	Reserved			To ensure compatibility with future devices, always write Reserved bits to their reset value, unless otherwise stated. More information in 1.2 Conventions
30	ADCWARM	0x0	R	ADCWARM The ADC analog front end and reference require a delay before converting when coming from a powered down or stand-by state. This status bit indicates that the analog front end and reference are ready.
29:25	Reserved			To ensure compatibility with future devices, always write Reserved bits to their reset value, unless otherwise stated. More information in 1.2 Conventions
24	SYNCBUSY	0x0	R	SYNCBUSY Indicates synchronization ongoing
23:22	Reserved			To ensure compatibility with future devices, always write Reserved bits to their reset value, unless otherwise stated. More information in 1.2 Conventions
21	MASKREQWRITE-PENDING	0x0	R	MASKREQ write pending A write to MASKREQ is pending. The ADC converts using a local working mask register, and only transfers MASKREQ to the local working version when the SCAN queue is not converting.
20	SINGLEWRITEPEND-ING	0x0	R	SINGLE write pending The SINGLE register write is pending. The ADC converts using a local working version of the SINGLE register, and only transfer SINGLE to the local working version when the SINGLE queue is not being converted.
19:17	Reserved			To ensure compatibility with future devices, always write Reserved bits to their reset value, unless otherwise stated. More information in 1.2 Conventions
16	TIMERACTIVE	0x0	R	Timer Active The local timer is running.
15	SCANFIFOFLUSHING	0x0	R	The Scan FIFO is flushing A scan data FIFO flush operation is in progress.
14	SINGLEFIFOFLUSHING	0x0	R	The Single FIFO is flushing A single data FIFO flush operation is in progress.

Bit	Name	Reset	Access	Description
13:10	<i>Reserved</i>	<i>To ensure compatibility with future devices, always write Reserved bits to their reset value, unless otherwise stated. More information in 1.2 Conventions</i>		
9	SCANFIFODV	0x0	R	SCANFIFO Data Valid At least one result in the scan FIFO is ready to read.
8	SINGLEFIFODV	0x0	R	SINGLEFIFO Data Valid At least one result in the single FIFO is ready to read.
7	<i>Reserved</i>	<i>To ensure compatibility with future devices, always write Reserved bits to their reset value, unless otherwise stated. More information in 1.2 Conventions</i>		
6	CONVERTING	0x0	R	Converting The ADC is warmed up and in the process of performing a conversion.
5	<i>Reserved</i>	<i>To ensure compatibility with future devices, always write Reserved bits to their reset value, unless otherwise stated. More information in 1.2 Conventions</i>		
4	SCANQUEUEPENDING	0x0	R	Scan Queue Pending The Scan queue has been triggered and is waiting to start conversion.
3	SCANQEN	0x0	R	Scan Queued Enabled The Scan queue is enabled.
2	<i>Reserved</i>	<i>To ensure compatibility with future devices, always write Reserved bits to their reset value, unless otherwise stated. More information in 1.2 Conventions</i>		
1	SINGLEQUEUEPEND- ING	0x0	R	Single Queue Pending The Single queue has been triggered and is waiting to start conversion. When tailgating is used, SINGLEQUEUEPEND-ING will remain high until the a scan operation has completed.
0	SINGLEQEN	0x0	R	Single Queue Enabled The Single queue is enabled.

23.5.7 IADC_MASKREQ - Mask Request

Offset	Bit Position																															
0x018	31	30	29	28	27	26	25	24	23	22	21	20	19	18	17	16	15	14	13	12	11	10	9	8	7	6	5	4	3	2	1	0
Reset																																0x0
Access																																RW
Name																																MASKREQ

Bit	Name	Reset	Access	Description
31:16	<i>Reserved</i>	<i>To ensure compatibility with future devices, always write Reserved bits to their reset value, unless otherwise stated. More information in 1.2 Conventions</i>		
15:0	MASKREQ	0x0	RW	Scan Queue Mask Request Allows software to specify which entries in the Scan table should be converted. For example MASKREQ = 0x8014 means that scan table entries 15, 4, and 2 will be converted. The other entries will not be converted.

23.5.8 IADC_STMASK - Scan Table Mask

Offset	Bit Position																															
0x01C	31	30	29	28	27	26	25	24	23	22	21	20	19	18	17	16	15	14	13	12	11	10	9	8	7	6	5	4	3	2	1	0
Reset																	0x0															
Access																	R															
Name																	STMASK															

Bit	Name	Reset	Access	Description
31:16	Reserved	To ensure compatibility with future devices, always write Reserved bits to their reset value, unless otherwise stated. More information in 1.2 Conventions		
15:0	STMASK	0x0	R	Scan Table Mask This is the active / working copy of the MASKREQ register that the ADC uses. It will only be updated at the end of a scan sequence or when no scan is in progress.

23.5.9 IADC_CMPTHR - Digital Window Comparator Threshold

Offset	Bit Position																															
0x020	31	30	29	28	27	26	25	24	23	22	21	20	19	18	17	16	15	14	13	12	11	10	9	8	7	6	5	4	3	2	1	0
Reset	0x0																0x0															
Access	RW																RW															
Name	ADGT																ADLT															

Bit	Name	Reset	Access	Description
31:16	ADGT	0x0	RW	ADC Greater Than or Equal to Threshold Compare threshold value for greater-than or equal to comparison. ADGT should be specified in a left-justified, 16-bit format regardless of the FIFO ALIGNMENT setting. Comparisons with 12-bit formats will ignore the 4 LSBs of the ADGT value. Comparisons with 20-bit formats will ignore the 4 LSBs of the 20-bit result. Unipolar or bipolar mode is considered in the comparison. When ADGT is greater than ADLT, the comparison is true if the result is either greater than ADGT or less than ADLT, but false if the result falls between the values.
15:0	ADLT	0x0	RW	ADC Less Than or Equal to Threshold Compare threshold value for less-than or equal to comparison. ADLT should be specified in a left-justified, 16-bit format regardless of the FIFO ALIGNMENT setting. Comparisons with 12-bit formats will ignore the 4 LSBs of the ADLT value. Comparisons with 20-bit formats will ignore the 4 LSBs of the 20-bit result. Unipolar or bipolar mode is considered in the comparison. When ADGT is greater than ADLT, the comparison is true if the result is either greater than ADGT or less than ADLT, but false if the result falls between the values.

23.5.10 IADC_IF - Interrupt Flags

Offset	Bit Position																															
0x024	31	30	29	28	27	26	25	24	23	22	21	20	19	18	17	16	15	14	13	12	11	10	9	8	7	6	5	4	3	2	1	0
Reset	0x0												0x0	0x0	0x0	0x0			0x0	0x0			0x0	0x0	0x0				0x0	0x0	0x0	0x0
Access	RW												RW	RW	RW	RW			RW	RW			RW	RW	RW				RW	RW	RW	RW
Name	EM23ABORTERROR												SCANFIFOUF	SINGLEFIFOUF	SCANFIFOOF	SINGLEFIFOOF			PORTALLOCERR	POLARITYERR			SINGLEDONE	SCANTABLEDONE	SCANENTRYDONE				SCANCMP	SINGLECMP	SCANFIFODVL	SINGLEFIFODVL

Bit	Name	Reset	Access	Description
31	EM23ABORTERROR	0x0	RW	EM2/3 Abort Error The system entered EM2 or EM3 during a conversion with an unsupported clock. Conversion results may be corrupted.
30:20	<i>Reserved</i>	<i>To ensure compatibility with future devices, always write Reserved bits to their reset value, unless otherwise stated. More information in 1.2 Conventions</i>		
19	SCANFIFOUF	0x0	RW	Scan FIFO Underflow A scan FIFO underflow has occurred.
18	SINGLEFIFOUF	0x0	RW	Single FIFO Underflow A single FIFO underflow has occurred.
17	SCANFIFOOF	0x0	RW	Scan FIFO Overflow A scan FIFO overflow has occurred.
16	SINGLEFIFOOF	0x0	RW	Single FIFO Overflow A single FIFO overflow has occurred.
15:14	<i>Reserved</i>	<i>To ensure compatibility with future devices, always write Reserved bits to their reset value, unless otherwise stated. More information in 1.2 Conventions</i>		
13	PORTALLOCERR	0x0	RW	Port Allocation Error A pin was selected on a port which has not been allocated to the IADC in GPIO control.
12	POLARITYERR	0x0	RW	Polarity Error Either two even channels or two odd channels were programmed into the channel mux selection. The ADC result will be set to 0xFFFF.
11:10	<i>Reserved</i>	<i>To ensure compatibility with future devices, always write Reserved bits to their reset value, unless otherwise stated. More information in 1.2 Conventions</i>		
9	SINGLEDONE	0x0	RW	Single Conversion Done A single conversion has completed.
8	SCANTABLEDONE	0x0	RW	Scan Table Done A scan sequence completed. Set at the end of a scan sequence after all valid entries of the scan table have completed.
7	SCANENTRYDONE	0x0	RW	Scan Entry Done A scan table conversion completed. Set at the completion of each valid entry of the scan table.

Bit	Name	Reset	Access	Description
6:4	<i>Reserved</i>	<i>To ensure compatibility with future devices, always write Reserved bits to their reset value, unless otherwise stated. More information in 1.2 Conventions</i>		
3	SCANCMP	0x0	RW	Scan Result Window Compare Scan digital compare window tripped.
2	SINGLECMP	0x0	RW	Single Result Window Compare Single digital compare window tripped.
1	SCANFIFODVL	0x0	RW	Scan FIFO Data Valid Level A minimum of (DVL+1) entries are ready to be read from the Scan FIFO.
0	SINGLEFIFODVL	0x0	RW	Single FIFO Data Valid Level A minimum of (DVL+1) entries are ready to be read from the Single FIFO.

23.5.11 IADC_IEN - Interrupt Enable

Offset	Bit Position																															
0x028	31	30	29	28	27	26	25	24	23	22	21	20	19	18	17	16	15	14	13	12	11	10	9	8	7	6	5	4	3	2	1	0
Reset	0x0												0x0	0x0	0x0	0x0			0x0	0x0			0x0	0x0	0x0				0x0	0x0	0x0	0x0
Access	RW												RW	RW	RW	RW			RW	RW			RW	RW	RW				RW	RW	RW	RW
Name	EM23ABORTERROR												SCANFIFOUF	SINGLEFIFOUF	SCANFIFOOF	SINGLEFIFOOF			PORTALLOCERR	POLARITYERR			SINGLEDONE	SCANTABLEDONE	SCANENTRYDONE				SCANCMP	SINGLECMP	SCANFIFODVL	SINGLEFIFODVL

Bit	Name	Reset	Access	Description
31	EM23ABORTERROR	0x0	RW	EM2/3 Abort Error Enable EM2/3 Abort Error Enable
30:20	<i>Reserved</i>	<i>To ensure compatibility with future devices, always write Reserved bits to their reset value, unless otherwise stated. More information in 1.2 Conventions</i>		
19	SCANFIFOUF	0x0	RW	Scan FIFO Underflow Enable Scan FIFO underflow interrupt enable
18	SINGLEFIFOUF	0x0	RW	Single FIFO Underflow Enable Single FIFO underflow interrupt enable
17	SCANFIFOOF	0x0	RW	Scan FIFO Overflow Enable Scan FIFO overflow interrupt enable
16	SINGLEFIFOOF	0x0	RW	Single FIFO Overflow Enable Single FIFO overflow interrupt enable
15:14	<i>Reserved</i>	<i>To ensure compatibility with future devices, always write Reserved bits to their reset value, unless otherwise stated. More information in 1.2 Conventions</i>		
13	PORTALLOCERR	0x0	RW	Port Allocation Error Enable Port Allocation Error Enable
12	POLARITYERR	0x0	RW	Polarity Error Enable Polarity Error Enable
11:10	<i>Reserved</i>	<i>To ensure compatibility with future devices, always write Reserved bits to their reset value, unless otherwise stated. More information in 1.2 Conventions</i>		
9	SINGLEDONE	0x0	RW	Single Conversion Done Enable Single Conversion Done interrupt enable
8	SCANTABLEDONE	0x0	RW	Scan Table Done Enable Scan Table Done interrupt enable
7	SCANENTRYDONE	0x0	RW	Scan Entry Done Enable Scan Entry Done interrupt enable

Bit	Name	Reset	Access	Description
6:4	<i>Reserved</i>	<i>To ensure compatibility with future devices, always write Reserved bits to their reset value, unless otherwise stated. More information in 1.2 Conventions</i>		
3	SCANCMP Scan Result Window Compare Enable	0x0	RW	Scan Result Window Compare Enable
2	SINGLECMP Single Result Window Compare Enable	0x0	RW	Single Result Window Compare Enable
1	SCANFIFODVL Scan FIFO Data Valid Level interrupt enable	0x0	RW	Scan FIFO Data Valid Level Enable
0	SINGLEFIFODVL Single FIFO Data Valid Level interrupt enable	0x0	RW	Single FIFO Data Valid Level Enable

23.5.12 IADC_TRIGGER - Trigger

Offset	Bit Position																																	
0x02C	31	30	29	28	27	26	25	24	23	22	21	20	19	18	17	16	15	14	13	12	11	10	9	8	7	6	5	4	3	2	1	0		
Reset																0x0				0x0					0x0					0x0				0x0
Access																RW				RW					RW					RW				RW
Name																SINGLETAILGATE				SINGLETRIGACTION					SINGLETRIGSEL					SCANTRIGACTION				SCANTRIGSEL

Bit	Name	Reset	Access	Description
31:17	<i>Reserved</i>	<i>To ensure compatibility with future devices, always write Reserved bits to their reset value, unless otherwise stated. More information in 1.2 Conventions</i>		
16	SINGLETAILGATE	0x0	RW	Single Tailgate Enable Enables tailgating.
	Value	Mode	Description	
	0	TAILGATEOFF	The single queue is ready to start warming up and converting once the trigger had been detected.	
	1	TAILGATEON	After the single queue's trigger is detected, it must wait until the end of a scan operation before the Single queue can be converted.	
15:13	<i>Reserved</i>	<i>To ensure compatibility with future devices, always write Reserved bits to their reset value, unless otherwise stated. More information in 1.2 Conventions</i>		
12	SINGLETRIGACTION	0x0	RW	Single Trigger Action Selects the trigger action for the single queue.
	Value	Mode	Description	
	0	ONCE	For TRIGSEL=IMMEDIATE, converts the single queue once and disables queue. For TRIGSEL = TIMER, PRSCLKGRP, PRSPOS, PRSNEG, converts the single queue once per trigger.	
	1	CONTINUOUS	Converts the single queue, then checks for a pending scan queue before converting the single queue again continuously. The queues are first come first serve. If both queues are continuous, the IADC alternates between them.	
11	<i>Reserved</i>	<i>To ensure compatibility with future devices, always write Reserved bits to their reset value, unless otherwise stated. More information in 1.2 Conventions</i>		
10:8	SINGLETRIGSEL	0x0	RW	Single Trigger Select Selects the trigger source for the single queue.
	Value	Mode	Description	

Bit	Name	Reset	Access	Description
0		IMMEDIATE		Immediate triggering. The single queue will be disabled once the conversion is complete, unless TRIGGERACTION is set to continuous.
1		TIMER		Triggers when the local timer count reaches zero.
2		PRCLKGRP		Triggers on PRS1 from a timer module that is using the same clock group as the ADC and has been programmed to use the same clock source as the ADC. The prescale may be different between the ADC and the timer module.
3		PRSPPOS		Triggers on asynchronous PRS1 positive edge. Requires PRS1 to go low for 3 ADC_CLKs before another positive edge can be detected. Generates an additional delay of 1 to 2 CLK_SRC_ADC cycles for synchronization.
4		PRSNNEG		Triggers on asynchronous PRS1 negative edge. Requires PRS1 to go high for 3 ADC_CLKs before another negative edge can be detected. Generates an additional delay of 1 to 2 CLK_SRC_ADC cycles for synchronization. PRSNNEG should only be used when the trigger source is from a module that remains powered during EM23. For modules (ie: TIMER) that power down during EM23, PRSPPOS should be used for an asynchronous trigger, and PRCLKGRP should be used for a synchronous trigger.
7:5	<i>Reserved</i>	<i>To ensure compatibility with future devices, always write Reserved bits to their reset value, unless otherwise stated. More information in 1.2 Conventions</i>		
4	SCANTRIGACTION	0x0	RW	Scan Trigger Action Selects the trigger action for the scan queue.
	Value	Mode		Description
	0	ONCE		For TRIGSEL=IMMEDIATE, goes through the scan table once and disables queue. For TRIGSEL = TIMER, PRCLKGRP, PRSPPOS, PRSNNEG, goes through the scan table once per trigger.
	1	CONTINUOUS		Goes through the scan table, converts each entry with a mask bit set, and puts it back into the scan queue to repeat again continuously. The queues are first come first serve. If both queues are triggered, the single queue will get to convert after each scan table completes. The scan queue will get to convert after each single conversion completes.
3	<i>Reserved</i>	<i>To ensure compatibility with future devices, always write Reserved bits to their reset value, unless otherwise stated. More information in 1.2 Conventions</i>		
2:0	SCANTRIGSEL	0x0	RW	Scan Trigger Select Selects the trigger source for the scan queue.
	Value	Mode		Description
	0	IMMEDIATE		Immediate triggering. The scan queue will be disabled once all conversions in the scan table are complete, unless TRIGGERACTION is set to continuous.
	1	TIMER		Triggers when the local timer count reaches zero.
	2	PRCLKGRP		Triggers on PRS0 from a timer module that is using the same clock group as the ADC and has been programmed to use the same clock source as the ADC. The prescale may be different between the ADC and the timer module.

Bit	Name	Reset	Access	Description
3		PRSPOS		Triggers on asynchronous PRS0 positive edge. Requires PRS0 to go low for 3 ADC_CLKs before another positive edge can be detected. Generates an additional delay of 1 to 2 CLK_SRC_ADC cycles for synchronization.
4		PRSNEG		Triggers on asynchronous PRS0 negative edge. Requires PRS0 to go high for 3 ADC_CLKs before another negative edge can be detected. Generates an additional delay of 1 to 2 CLK_SRC_ADC cycles for synchronization. PRSNEG should only be used when the trigger source is from a module that remains powered during EM23. For modules (ie: TIMER) that power down during EM23, PRSPOS should be used for an asynchronous trigger, and PRSCLKGRP should be used for a synchronous trigger.

23.5.13 IADC_CFGx - Configuration

Offset	Bit Position																																	
0x048	31	30	29	28	27	26	25	24	23	22	21	20	19	18	17	16	15	14	13	12	11	10	9	8	7	6	5	4	3	2	1	0		
Reset			0x0							0x0					0x0					0x2							0x3				0x0			0x0
Access			RW							RW					RW												RW				RW			RW
Name			TWOSCOMPL							DIGAVG					REFSEL						ANALOGGAIN							OSRHA			OSRHS			ADCMODE

Bit	Name	Reset	Access	Description
31:30	<i>Reserved</i>	<i>To ensure compatibility with future devices, always write Reserved bits to their reset value, unless otherwise stated. More information in 1.2 Conventions</i>		
29:28	TWOSCOMPL	0x0	RW	Two's Complement Selects output word polarity.
	Value	Mode	Description	
	0	AUTO	Automatic: Single ended measurements are reported as unipolar and differential measurements are reported as bipolar.	
	1	FORCEUNIPOLAR	Force all measurements to result in unipolar output. Negative differential numbers will saturate to 0.	
	2	FORCEBIPOLAR	Force all measurements to result in bipolar output. Single ended measurements are half the range, but allow for small negative measurements.	
27:24	<i>Reserved</i>	<i>To ensure compatibility with future devices, always write Reserved bits to their reset value, unless otherwise stated. More information in 1.2 Conventions</i>		
23:21	DIGAVG	0x0	RW	Digital Averaging Number of output words to convert and average.
	Value	Mode	Description	
	0	AVG1	Collect one output word (no digital averaging).	
	1	AVG2	Collect and average 2 digital output words.	
	2	AVG4	Collect and average 4 digital output words.	
	3	AVG8	Collect and average 8 digital output words.	
	4	AVG16	Collect and average 16 digital output words.	
20:19	<i>Reserved</i>	<i>To ensure compatibility with future devices, always write Reserved bits to their reset value, unless otherwise stated. More information in 1.2 Conventions</i>		
18:16	REFSEL	0x0	RW	Reference Select Selects voltage reference.
	Value	Mode	Description	
	0	VBGR	Internal 1.21 V reference.	

Bit	Name	Reset	Access	Description
	1	VREF		External Reference. (Calibrated for 1.25V nominal.)
	2	VREF2P5		External Reference. Supports 2.5V in high accuracy mode.
	3	VDDX		AVDD (unbuffered)
	4	VDDX0P8BUF		AVDD (buffered) * 0.8
15	<i>Reserved</i>	<i>To ensure compatibility with future devices, always write Reserved bits to their reset value, unless otherwise stated. More information in 1.2 Conventions</i>		
14:12	ANALOGGAIN	0x2	RW	Analog Gain Sets analog front end gain.
	Value	Mode	Description	
	1	ANAGAIN0P5	Analog gain of 0.5x.	
	2	ANAGAIN1	Analog gain of 1x.	
	3	ANAGAIN2	Analog gain of 2x.	
	4	ANAGAIN3	Analog gain of 3x.	
	5	ANAGAIN4	Analog gain of 4x.	
11:8	<i>Reserved</i>	<i>To ensure compatibility with future devices, always write Reserved bits to their reset value, unless otherwise stated. More information in 1.2 Conventions</i>		
7:5	OSRHA	0x3	RW	High Accuracy OSR Over sampling ratio for high accuracy conversions.
	Value	Mode	Description	
	0	HIACC16	High accuracy over sampling of 16x.	
	1	HIACC32	High accuracy over sampling of 32x.	
	2	HIACC64	High accuracy over sampling of 64x.	
	3	HIACC92	High accuracy over sampling of 92x.	
	4	HIACC128	High accuracy over sampling of 128x.	
	5	HIACC256	High accuracy over sampling of 256x.	
4:2	OSRHS	0x0	RW	High Speed OSR Over sampling ratio for high speed conversions.
	Value	Mode	Description	
	0	HISPD2	High speed over sampling of 2x.	
	1	HISPD4	High speed over sampling of 4x.	
	2	HISPD8	High speed over sampling of 8x.	
	3	HISPD16	High speed over sampling of 16x.	
	4	HISPD32	High speed over sampling of 32x.	
	5	HISPD64	High speed over sampling of 64x.	
1:0	ADCMODE	0x0	RW	ADC Mode Selects ADC conversion mode.

Bit	Name	Reset	Access	Description
	Value	Mode		Description
0		NORMAL		High speed mode with a maximum ADC_CLK of 10 MHz.
1		HIGHSPEED		Double high speed mode with a maximum ADC_CLK of 20 MHz. Power consumption is boosted to allow faster conversions.
2		HIGHACCURACY		High accuracy mode with maximum ADC_CLK of 5 MHz.

23.5.14 IADC_SCALEx - Scaling

Offset	Bit Position																															
0x050	31	30	29	28	27	26	25	24	23	22	21	20	19	18	17	16	15	14	13	12	11	10	9	8	7	6	5	4	3	2	1	0
Reset	0x1														0x0														0x2C000			
Access	RW														RW														RW			
Name	GAIN3MSB														GAIN13LSB														OFFSET			

Bit	Name	Reset	Access	Description
31	GAIN3MSB	0x1	RW	Gain 3 MSBs 3 MSBs of the 16-bit gain value (0=011 or 0.75; 1=1xx or 1.00). Example {GAIN3MSB, GAIN13LSB} = {100, 0_1001_0000_0000} = 1.07031x. Example {GAIN3MSB, GAIN13LSB} = {011, 0_0000_1010_0010} = 0.75494x.
	Value	Mode		Description
	0	GAIN011		Upper 3 bits of gain = 011 (0.75x)
	1	GAIN100		Upper 3 bits of gain = 100 (1.00x)
30:18	GAIN13LSB	0x0	RW	Gain 13 LSBs 13 LSBs of the 16-bit gain value.
17:0	OFFSET	0x2C000	RW	Offset Offset

23.5.15 IADC_SCHEx - Scheduling

Offset	Bit Position																															
0x054	31	30	29	28	27	26	25	24	23	22	21	20	19	18	17	16	15	14	13	12	11	10	9	8	7	6	5	4	3	2	1	0
Reset																	0x0															
Access																	RW															
Name																	PRESCALE															

Bit	Name	Reset	Access	Description
31:10	Reserved	To ensure compatibility with future devices, always write Reserved bits to their reset value, unless otherwise stated. More information in 1.2 Conventions		
9:0	PRESCALE	0x0	RW	Prescale Second level prescaler - divides the CLK_SRC_ADC by (PRESCALE + 1) to generate ADC_CLK. PRESCALE=0 should only be used with HSCLKRATE=0. (See text.)

23.5.16 IADC_SINGLEFIFOCFG - Single FIFO Configuration

Offset	Bit Position																																																						
0x070	31	30	29	28	27	26	25	24	23	22	21	20	19	18	17	16	15	14	13	12	11	10	9	8	7	6	5	4	3	2	1	0																							
Reset																								0x0			0x3		0x0		0x0																								
Access																								RW			RW		RW		RW																								
Name																								DMAWUFIFOSINGLE			DVL		SHOWID																										

Bit	Name	Reset	Access	Description																								
31:9	<i>Reserved</i>	<i>To ensure compatibility with future devices, always write Reserved bits to their reset value, unless otherwise stated. More information in 1.2 Conventions</i>																										
8	DMAWUFIFOSINGLE	0x0	RW	Single FIFO DMA wakeup. Enables single FIFO to wake DMA in EM2 or EM3. <table border="1"> <thead> <tr> <th>Value</th> <th>Mode</th> <th>Description</th> </tr> </thead> <tbody> <tr> <td>0</td> <td>DISABLED</td> <td>While in EM2 or EM3, the DMA controller will not be requested.</td> </tr> <tr> <td>1</td> <td>ENABLED</td> <td>While in EM2 or EM3, the DMA controller will be requested when the single FIFO reaches its Data Valid Level. [DVL must be set to 0 (VALID1).]</td> </tr> </tbody> </table>	Value	Mode	Description	0	DISABLED	While in EM2 or EM3, the DMA controller will not be requested.	1	ENABLED	While in EM2 or EM3, the DMA controller will be requested when the single FIFO reaches its Data Valid Level. [DVL must be set to 0 (VALID1).]															
Value	Mode	Description																										
0	DISABLED	While in EM2 or EM3, the DMA controller will not be requested.																										
1	ENABLED	While in EM2 or EM3, the DMA controller will be requested when the single FIFO reaches its Data Valid Level. [DVL must be set to 0 (VALID1).]																										
7	<i>Reserved</i>	<i>To ensure compatibility with future devices, always write Reserved bits to their reset value, unless otherwise stated. More information in 1.2 Conventions</i>																										
6:4	DVL	0x3	RW	Data Valid Level Data valid level before requesting DMA transfer. If the number of words in the FIFO reaches or exceeds DVL+1, DMA requests will be generated. <table border="1"> <thead> <tr> <th>Value</th> <th>Mode</th> <th>Description</th> </tr> </thead> <tbody> <tr> <td>0</td> <td>VALID1</td> <td>When 1 entry in the single FIFO is valid, set the SINGLEFI-FODVL interrupt and request DMA.</td> </tr> <tr> <td>1</td> <td>VALID2</td> <td>When 2 entries in the single FIFO are valid, set the SINGLEFI-FODVL interrupt and request DMA.</td> </tr> <tr> <td>2</td> <td>VALID3</td> <td>When 3 entries in the single FIFO are valid, set the SINGLEFI-FODVL interrupt and request DMA.</td> </tr> <tr> <td>3</td> <td>VALID4</td> <td>When 4 entries in the single FIFO are valid, set the SINGLEFI-FODVL interrupt and request DMA.</td> </tr> <tr> <td>4</td> <td>VALID5</td> <td>When 5 entries in the single FIFO are valid, set the SINGLEFI-FODVL interrupt and request DMA.</td> </tr> <tr> <td>5</td> <td>VALID6</td> <td>When 6 entries in the single FIFO are valid, set the SINGLEFI-FODVL interrupt and request DMA.</td> </tr> <tr> <td>6</td> <td>VALID7</td> <td>When 7 entries in the single FIFO are valid, set the SINGLEFI-FODVL interrupt and request DMA.</td> </tr> </tbody> </table>	Value	Mode	Description	0	VALID1	When 1 entry in the single FIFO is valid, set the SINGLEFI-FODVL interrupt and request DMA.	1	VALID2	When 2 entries in the single FIFO are valid, set the SINGLEFI-FODVL interrupt and request DMA.	2	VALID3	When 3 entries in the single FIFO are valid, set the SINGLEFI-FODVL interrupt and request DMA.	3	VALID4	When 4 entries in the single FIFO are valid, set the SINGLEFI-FODVL interrupt and request DMA.	4	VALID5	When 5 entries in the single FIFO are valid, set the SINGLEFI-FODVL interrupt and request DMA.	5	VALID6	When 6 entries in the single FIFO are valid, set the SINGLEFI-FODVL interrupt and request DMA.	6	VALID7	When 7 entries in the single FIFO are valid, set the SINGLEFI-FODVL interrupt and request DMA.
Value	Mode	Description																										
0	VALID1	When 1 entry in the single FIFO is valid, set the SINGLEFI-FODVL interrupt and request DMA.																										
1	VALID2	When 2 entries in the single FIFO are valid, set the SINGLEFI-FODVL interrupt and request DMA.																										
2	VALID3	When 3 entries in the single FIFO are valid, set the SINGLEFI-FODVL interrupt and request DMA.																										
3	VALID4	When 4 entries in the single FIFO are valid, set the SINGLEFI-FODVL interrupt and request DMA.																										
4	VALID5	When 5 entries in the single FIFO are valid, set the SINGLEFI-FODVL interrupt and request DMA.																										
5	VALID6	When 6 entries in the single FIFO are valid, set the SINGLEFI-FODVL interrupt and request DMA.																										
6	VALID7	When 7 entries in the single FIFO are valid, set the SINGLEFI-FODVL interrupt and request DMA.																										

Bit	Name	Reset	Access	Description
7		VALID8		When 8 entries in the single FIFO are valid, set the SINGLEFI-FODVL interrupt and request DMA.
3	SHOWID	0x0	RW	Show ID ID of 0x20 will be applied in the output words.
2:0	ALIGNMENT	0x0	RW	Alignment Alignment of output data written into FIFO.
	Value	Mode		Description
	0	RIGHT12		ID[7:0], SIGN_EXT, DATA[11:0]
	1	RIGHT16		ID[7:0], SIGN_EXT, DATA[15:0]
	2	RIGHT20		ID[7:0], SIGN_EXT, DATA[19:0]
	3	LEFT12		DATA[11:0], 000000000000, ID[7:0]
	4	LEFT16		DATA[15:0], 00000000, ID[7:0]
	5	LEFT20		DATA[19:0], 0000, ID[7:0]

23.5.17 IADC_SINGLEFIFODATA - Single FIFO DATA

Offset	Bit Position																															
0x074	31	30	29	28	27	26	25	24	23	22	21	20	19	18	17	16	15	14	13	12	11	10	9	8	7	6	5	4	3	2	1	0
Reset	0x0																															
Access	R(r)																															
Name	DATA																															

Bit	Name	Reset	Access	Description
31:0	DATA	0x0	R(r)	Single FIFO Read Data Reads and pops the oldest value from the single FIFO.

23.5.18 IADC_SINGLEFIFOSTAT - Single FIFO Status

Offset	Bit Position																															
0x078	31	30	29	28	27	26	25	24	23	22	21	20	19	18	17	16	15	14	13	12	11	10	9	8	7	6	5	4	3	2	1	0
Reset																												0x0				
Access																														R		
Name																														FIFOREADCNT		

Bit	Name	Reset	Access	Description
31:4	Reserved	To ensure compatibility with future devices, always write Reserved bits to their reset value, unless otherwise stated. More information in 1.2 Conventions		
3:0	FIFOREADCNT	0x0	R	FIFO Read Count Number of valid entries available to read.

23.5.19 IADC_SINGLEDATA - Single Data

Offset	Bit Position																															
0x07C	31	30	29	28	27	26	25	24	23	22	21	20	19	18	17	16	15	14	13	12	11	10	9	8	7	6	5	4	3	2	1	0
Reset																												0x0				
Access																														R		
Name																														DATA		

Bit	Name	Reset	Access	Description
31:0	DATA	0x0	R	Data Reads the most recent data word from the single FIFO, but does not pop a value. Even if the FIFO has overflowed and stopped updating, the most recent conversion will continue to overwrite SINGLEDATA.

23.5.20 IADC_SCANFIFOCFG - Scan FIFO Configuration

Offset	Bit Position																															
0x080	31	30	29	28	27	26	25	24	23	22	21	20	19	18	17	16	15	14	13	12	11	10	9	8	7	6	5	4	3	2	1	0
Reset																								0x0			0x3		0x0		0x0	
Access																								RW			RW		RW		RW	
Name																								DMAWUFIFOSCAN			DVL		SHOWID		ALIGNMENT	

Bit	Name	Reset	Access	Description
31:9	<i>Reserved</i>	<i>To ensure compatibility with future devices, always write Reserved bits to their reset value, unless otherwise stated. More information in 1.2 Conventions</i>		
8	DMAWUFIFOSCAN	0x0	RW	Scan FIFO DMA Wakeup Enables scan FIFO to wake DMA in EM2 or EM3.
	Value	Mode	Description	
	0	DISABLED	While in EM2 or EM3, the DMA controller will not be requested.	
	1	ENABLED	While in EM2 or EM3, the DMA controller will be requested when the scan FIFO reaches its Data Valid Level. [DVL must be set to 0 (VALID1).]	
7	<i>Reserved</i>	<i>To ensure compatibility with future devices, always write Reserved bits to their reset value, unless otherwise stated. More information in 1.2 Conventions</i>		
6:4	DVL	0x3	RW	Data Valid Level Data valid level before requesting DMA transfer. If the number of words in the FIFO reaches or exceeds DVL+1, DMA requests will be generated.
	Value	Mode	Description	
	0	VALID1	When 1 entry in the scan FIFO is valid, set the SCANFIFODVL interrupt and request DMA.	
	1	VALID2	When 2 entries in the scan FIFO are valid, set the SCANFIFODVL interrupt and request DMA.	
	2	VALID3	When 3 entries in the scan FIFO are valid, set the SCANFIFODVL interrupt and request DMA.	
	3	VALID4	When 4 entries in the scan FIFO are valid, set the SCANFIFODVL interrupt and request DMA.	
	4	VALID5	When 5 entries in the scan FIFO are valid, set the SCANFIFODVL interrupt and request DMA.	
	5	VALID6	When 6 entries in the scan FIFO are valid, set the SCANFIFODVL interrupt and request DMA.	
	6	VALID7	When 7 entries in the scan FIFO are valid, set the SCANFIFODVL interrupt and request DMA.	

Bit	Name	Reset	Access	Description
7		VALID8		When 8 entries in the scan FIFO are valid, set the SCANFI-FODVL interrupt and request DMA.
3	SHOWID	0x0	RW	Show ID Enable ID in output words.
2:0	ALIGNMENT	0x0	RW	Alignment Alignment of output data written into FIFO.
	Value	Mode		Description
	0	RIGHT12		ID[7:0], SIGN_EXT, DATA[11:0]
	1	RIGHT16		ID[7:0], SIGN_EXT, DATA[15:0]
	2	RIGHT20		ID[7:0], SIGN_EXT, DATA[19:0]
	3	LEFT12		DATA[11:0], 000000000000, ID[7:0]
	4	LEFT16		DATA[15:0], 00000000, ID[7:0]
	5	LEFT20		DATA[19:0], 0000, ID[7:0]

23.5.21 IADC_SCANFIFODATA - Scan FIFO Read Data

Offset	Bit Position																															
0x084	31	30	29	28	27	26	25	24	23	22	21	20	19	18	17	16	15	14	13	12	11	10	9	8	7	6	5	4	3	2	1	0
Reset	0x0																															
Access	R(r)																															
Name	DATA																															

Bit	Name	Reset	Access	Description
31:0	DATA	0x0	R(r)	Data Reads and pops the oldest value from the scan FIFO.

23.5.22 IADC_SCANFIFOSTAT - Scan FIFO Status

Offset	Bit Position																															
0x088	31	30	29	28	27	26	25	24	23	22	21	20	19	18	17	16	15	14	13	12	11	10	9	8	7	6	5	4	3	2	1	0
Reset																												0x0		0		
Access																												R				
Name																												FIFOREADCNT				

Bit	Name	Reset	Access	Description
31:4	Reserved	To ensure compatibility with future devices, always write Reserved bits to their reset value, unless otherwise stated. More information in 1.2 Conventions		
3:0	FIFOREADCNT	0x0	R	FIFO Read Count Number of valid entries available to read.

23.5.23 IADC_SCANDATA - Scan Data

Offset	Bit Position																															
0x08C	31	30	29	28	27	26	25	24	23	22	21	20	19	18	17	16	15	14	13	12	11	10	9	8	7	6	5	4	3	2	1	0
Reset																												0x0				
Access																												R				
Name																												DATA				

Bit	Name	Reset	Access	Description
31:0	DATA	0x0	R	Data Reads the most recent data word from the scan FIFO, but does not pop a value. Even if the FIFO has overflowed and stopped updating, the most recent conversion will continue to overwrite SCANDATA.

23.5.24 IADC_SINGLE - Single Queue Port Selection

Offset	Bit Position																															
0x098	31	30	29	28	27	26	25	24	23	22	21	20	19	18	17	16	15	14	13	12	11	10	9	8	7	6	5	4	3	2	1	0
Reset															0x0	0x0	0x0				0x0				0x0				0x0			
Access															RW	RW	RW				RW				RW				RW			
Name															CMP	CFG	PORTPOS				PINPOS				PORTNEG				PINNEG			

Bit	Name	Reset	Access	Description
31:18	<i>Reserved</i>	<i>To ensure compatibility with future devices, always write Reserved bits to their reset value, unless otherwise stated. More information in 1.2 Conventions</i>		
17	CMP	0x0	RW	Comparison Enable Enable digital window comparison for this entry.
16	CFG	0x0	RW	Configuration Group Select Select which configuration group (CFGx, SCALEx, SCHEDx registers) is used with this entry.
	Value	Mode	Description	
	0	CONFIG0	Use configuration group 0	
	1	CONFIG1	Use configuration group 1	
15:12	PORTPOS	0x0	RW	Positive Port Select Port (A, B, C, D) or special signal assigned to the positive input of the ADC
	Value	Mode	Description	
	0	GND	Ground	
	1	SUPPLY	Supply Pin - Select specific supply using PINPOS	
	2	DAC0	Direct connection to DAC0_CH0	
	4	PADANA0	Direct connection to AIN0 input pin	
	5	PADANA2	Direct connection to AIN2 input pin	
	8	PORTA	Port A - Select pin number using PINPOS	
	9	PORTB	Port B - Select pin number using PINPOS	
	10	PORTC	Port C - Select pin number using PINPOS	
	11	PORTD	Port D - Select pin number using PINPOS	
11:8	PINPOS	0x0	RW	Positive Pin Select Pin number for the positive input of the ADC.
7:4	PORTNEG	0x0	RW	Negative Port Select Port (A, B, C, D) or special signal assigned to the negative input of the ADC
	Value	Mode	Description	
	0	GND	Ground (single-ended)	

Bit	Name	Reset	Access	Description
2		DAC1		Direct connection to DAC0_CH1
4		PADANA1		Direct connection to AIN1 input pin
5		PADANA3		Direct connection to AIN3 input pin
8		PORTA		Port A - Select pin number using PINNEG
9		PORTB		Port B - Select pin number using PINNEG
10		PORTC		Port C - Select pin number using PINNEG
11		PORTD		Port D - Select pin number using PINNEG
3:0	PINNEG	0x0	RW	Negative Pin Select Pin number for the negative input of the ADC.

23.5.25 IADC_SCANx - SCAN Entry

Offset	Bit Position																															
0x0A0	31	30	29	28	27	26	25	24	23	22	21	20	19	18	17	16	15	14	13	12	11	10	9	8	7	6	5	4	3	2	1	0
Reset															0x0	0x0	0x0				0x0				0x0				0x0			
Access															RW	RW	RW				RW				RW				RW			
Name															CMP	CFG	PORTPOS				PINPOS				PORTNEG				PINNEG			

Bit	Name	Reset	Access	Description
31:18	<i>Reserved</i>	<i>To ensure compatibility with future devices, always write Reserved bits to their reset value, unless otherwise stated. More information in 1.2 Conventions</i>		
17	CMP	0x0	RW	Comparison Enable Enable digital window comparison for this entry.
16	CFG	0x0	RW	Configuration Group Select Select which configuration group (CFGx, SCALEx, SCHEDx registers) is used with this entry.
	Value	Mode	Description	
	0	CONFIG0	Use configuration group 0	
	1	CONFIG1	Use configuration group 1	
15:12	PORTPOS	0x0	RW	Positive Port Select Port (A, B, C, D) or special signal assigned to the positive input of the ADC
	Value	Mode	Description	
	0	GND	Ground	
	1	SUPPLY	Supply Pin - Select specific supply using PINPOS	
	2	DAC0	Direct connection to DAC0_CH0	
	4	PADANA0	Direct connection to AIN0 input pin	
	5	PADANA2	Direct connection to AIN2 input pin	
	8	PORTA	Port A - Select pin number using PINPOS	
	9	PORTB	Port B - Select pin number using PINPOS	
	10	PORTC	Port C - Select pin number using PINPOS	
	11	PORTD	Port D - Select pin number using PINPOS	
11:8	PINPOS	0x0	RW	Positive Pin Select Pin number for the positive input of the ADC.
7:4	PORTNEG	0x0	RW	Negative Port Select Port (A, B, C, D) or special signal assigned to the negative input of the ADC
	Value	Mode	Description	
	0	GND	Ground (single-ended)	

Bit	Name	Reset	Access	Description
2		DAC1		Direct connection to DAC0_CH1
4		PADANA1		Direct connection to AIN1 input pin
5		PADANA3		Direct connection to AIN3 input pin
8		PORTA		Port A - Select pin number using PINNEG
9		PORTB		Port B - Select pin number using PINNEG
10		PORTC		Port C - Select pin number using PINNEG
11		PORTD		Port D - Select pin number using PINNEG
3:0	PINNEG	0x0	RW	Negative Pin Select Pin number for the negative input of the ADC.

24. GPIO - General Purpose Input/Output

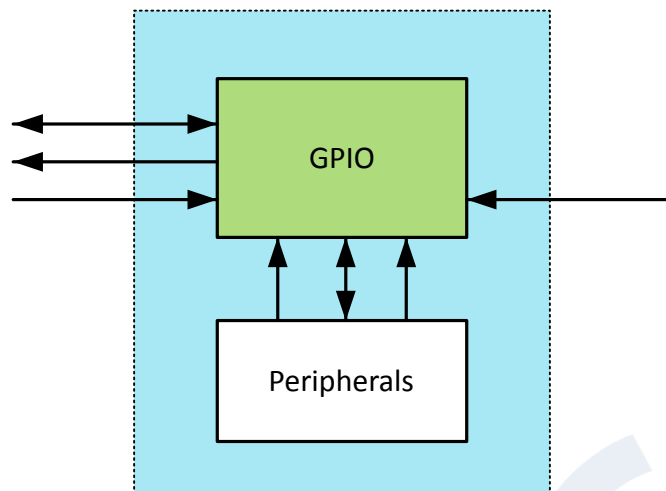
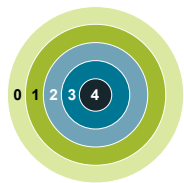

Quick Facts

What?

The General Purpose Input/Output (GPIO) is used for pin configurations as well as routing for peripheral pin connections.

Why?

Easy to use and highly configurable input/output pins are important to fit many communication protocols as well as minimizing software control overhead. Flexible routing of peripheral functions helps to ease PCB layout.

How?

Each pin on the device can be individually configured as either an input or an output with several different drive modes. Also, individual bit manipulation registers minimize control overhead. Peripheral connections to pins can be routed to pins as desired solving congestion and contention issues that may arise with limited routing flexibility. Fully asynchronous interrupts can also be generated from any pin.

24.1 Introduction

In the EFR32xG24 devices the General Purpose Input/Output (GPIO) pins are organized into ports with up to 16 pins each. These GPIO pins can be individually configured as either an output or input. More advanced configurations like open-drain, open-source, and glitch filtering can be configured for each individual GPIO pin. Peripheral resources, like Timer PWM outputs or USART RX/TX can be routed to the GPIO pins as desired by the user. Finally, the input value of a pin can be routed through the Peripheral Reflex System to other peripherals or used to trigger an external interrupt.

24.2 Features

- Individual configuration for each pin
 - Tristate (reset state)
 - Push-pull
 - Open-drain
 - Pull-up resistor
 - Pull-down resistor
 - Programmable Slewrate Control
- EM4 IO pin retention
 - Output enable
 - Output value
 - Pull enable
 - Pull direction
- EM4 wake-up on selected GPIO pins
- Glitch suppression input filter
- Extremely flexible analog and digital resource routing
- Toggle register for output data
- Dedicated data input register (read-only)
- Interrupts
 - Two independent interrupt vectors
 - All GPIO pins are selectable as interrupts in EM0 and EM1
 - All PA and PB GPIO pins are also selectable as interrupts down to EM2 and EM3
 - All EM4 wake-up pins are also available as interrupts in EM0/1/2/3
 - Separate enable, status, set and clear registers
 - Asynchronous sensing
 - Rising, falling or both edges
- Peripheral Reflex System producer
 - All GPIO pins are selectable

24.3 Functional Description

An overview of the GPIO module is shown in [Figure 24.1 Pin Configuration on page 809](#). The GPIO pins are grouped into 16-pin ports. Each individual GPIO pin is called P_{xn} where x indicates the port (A, B, C ...) and n indicates the pin number (0,1,...,15). Fewer than 16 pins may be available on some ports depending on the total number of I/O pins on the package. After a reset, both input and output are disabled for all pins on the device, except for the Serial Wire Debug pins.

To use a pin, the Mode Register (GPIO_P_x_MODEL/GPIO_P_x_MODEH) must be configured for the pin to make it an input or output. These registers can also do more advanced configuration, which is covered in [24.3.1 Pin Configuration](#). When the port is configured as an input or an output, the Data In Register (GPIO_P_x_DIN) can be used to read the level of each pin in the port (bit n in the register is connected to pin n on the port). When configured as an output, the value of the Data Out Register (GPIO_P_x_DOUT) will be driven to the pin.

The DOUT value can be changed in 4 different ways:

- Writing to the GPIO_P_x_DOUT register
- Writing the SET address of the GPIO_P_x_DOUT register sets the DOUT bits
- Writing the CLEAR address of the GPIO_P_x_DOUT register clears the DOUT bits
- Writing the GPIO_P_x_DOUTTGL register toggles the corresponding DOUT bits

Reading the GPIO_P_x_DOUT register will return its contents. Reading the GPIO_P_x_DOUTTGL register will return 0.

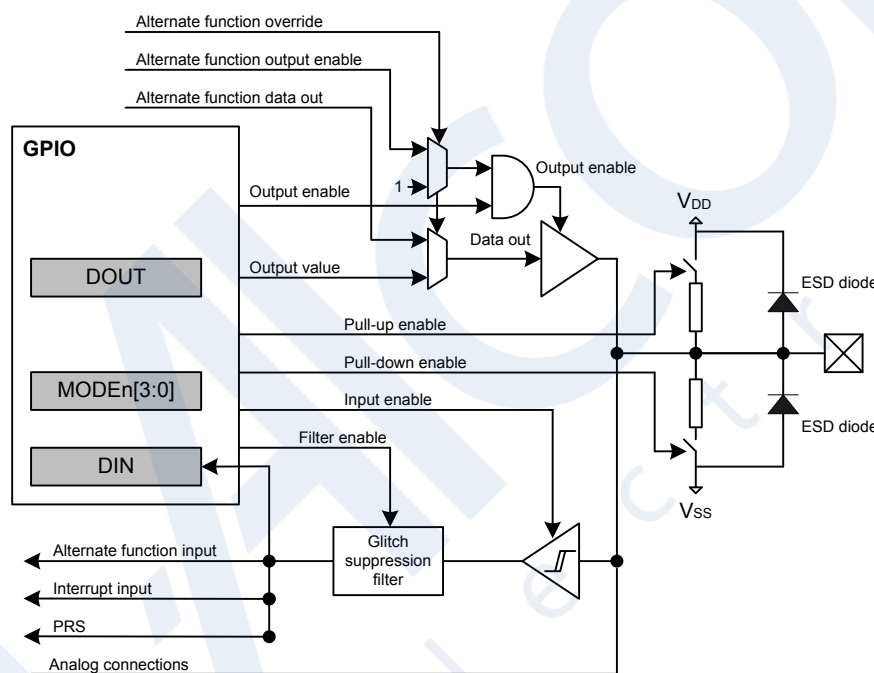

Figure 24.1. Pin Configuration

24.3.1 Pin Configuration

In addition to setting the pins as either outputs or inputs, the GPIO_Px_MODEL and GPIO_Px_MODEH registers can be used for more advanced configurations. GPIO_Px_MODEL contains 8 bit fields named MODEn (n=0,1,..7) which control pins 0-7, while GPIO_Px_MODEH contains 8 bit fields named MODEn (n=8,9,..15) which control pins 8-15. In some modes GPIO_Px_DOUT is also used for extra configurations like pull-up/down and glitch suppression filter enable. [Table 24.1 Pin Configuration on page 810](#) shows the available configurations.

Table 24.1. Pin Configuration

MODEn	Input	Output	DOUT	Pull-down	Pull-up	Alt Port Ctrl	Input Filter	Description
DISABLED	Disabled	Disabled	0					Input disabled
			1		On			Input disabled with pull-up
INPUT	Enabled if not DINDIS	Disabled	0					Input enabled
			1				On	Input enabled with filter
INPUTPULL		0	On					Input enabled with pull-down
		1		On				Input enabled with pull-up
INPUTPULLFILTER		0	On				On	Input enabled with pull-down and filter
		1		On			On	Input enabled with pull-up and filter
PUSHPULL		Push-pull	x					Push-pull
PUSHPULLALT			x			On		Push-pull with alternate port control values
WIREDOR		Open Source (Wired-OR)	x					Open-source
WIREDORPULLDOWN			x	On				Open-source with pull-down
WIREDAND	Open Drain (Wired-AND)	x					Open-drain	
WIREDANDFILTER		x				On	Open-drain with filter	
WIREDANDPULLUP		x		On			Open-drain with pull-up	
WIREDANDPULLUPFILTER		x		On		On	Open-drain with pull-up and filter	
WIREDANDALT		x				On	Open-drain with alternate port control values	
WIREDANDALTFILTER		x				On	On	Open-drain with alternate port control values and filter
WIREDANDALTPULLUP		x		On	On		Open-drain with alternate port control values and pull-up	
WIREDANDALTPULLUPFILTER		x		On	On	On	Open-drain with alternate port control values, pull-up and filter	

MODEn determines which mode the pin is in at a given time. Setting MODEn to DISABLED disables the pin, reducing power consumption to a minimum. When the output driver and input driver are disabled, the pin can be used as a connection for an analog module. An input is enabled by setting MODEn to any value other than DISABLED while DINDIS for the given port is cleared. Set DINDIS to disable

the input of a GPIO port. The pull-up, pull-down and glitch filter function can optionally be applied to the input, see [Figure 24.2 Tristated Output with Optional Pull-up or Pull-down on page 811](#).

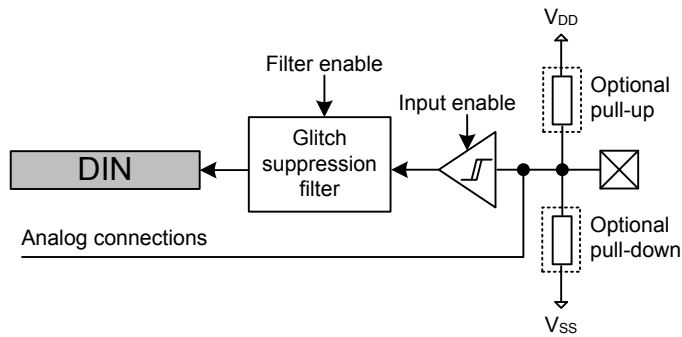

Figure 24.2. Tristated Output with Optional Pull-up or Pull-down

When $MODEn$ is $PUSHPULL$ or $PUSHPULLALT$, the pin operates in push-pull mode. In this mode, the pin can have alternate port control values and can be driven either high or low, dependent on the value of $GPIO_Px_DOUT$. The push-pull configuration is shown in [Figure 24.3 Push-Pull Configuration on page 811](#).

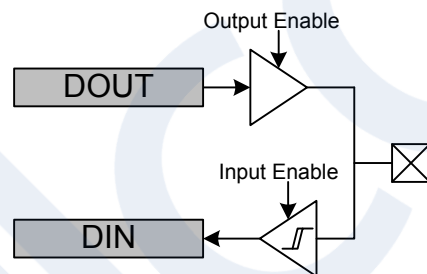

Figure 24.3. Push-Pull Configuration

When $MODEn$ is $WIREDOR$ or $WIREDORPULLDOWN$, the pin operates in open-source mode (with a pull-down resistor for $WIREDORPULLDOWN$). When driving a high value in open-source mode, the pull-down is disconnected to save power.

When the mode is prefixed with $WIREDAND$, the pin operates in open-drain mode as shown in [Figure 24.4 Open-drain on page 811](#). In open-drain mode, the pin can have an input filter, a pull-up, alternate port control values or any combination of these. When driving a low value in open-drain mode, the pull-up is disconnected to save power.

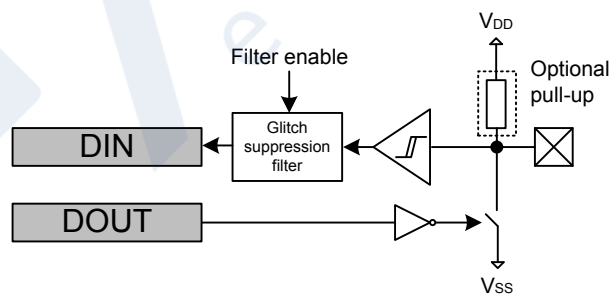

Figure 24.4. Open-drain

24.3.2 Alternate Port Control

The Alternate Port Control allows for additional flexibility of port level settings. A user may setup two different port configurations (normal and alternate modes) and select which is applied on a pin by pin bases. For example you may configure half of port A to use the slowest slew rate while the other half uses a faster slew rate.

Alternate port control is enabled when `MODEn` is set to any of the ALT enumerated modes (i.e., PUSH/PULL/ALT). When `MODEn` is an alternate mode, the pin uses the alternate port control values specified in the `DINDISALT` and `SLEWRATEALT` fields in `GPIO_Px_CTRL`. In all other modes, the port control values are used from the `DINDIS` and `SLEWRATE` fields in `GPIO_Px_CTRL`.

24.3.3 Slew Rate

The slewrate can be applied to pins on a port-by-port basis. The slew rate applied to pins configured using normal `MODEn` settings can be controlled using the `SLEWRATE` fields in `GPIO_Px_CTRL`. The slewrate applied to pins configured using the alternate `MODEn` settings can be controlled using the `SLEWRATEALT` field.

The lowest slew rate setting has limited drive strength. That is the current is limited to about 1 mA. This setting provides slow switching and limited drive. A slew rate setting of 1 provides the slowest switching with full drive capability. The maximum recommended setting for most digital I/O is 6. A slew rate setting of 7 should only be used for high-speed clock signals, above 10 MHz. A setting of 7 should not be used on more than one pin per port. Please refer to the datasheet for GPIO rise and fall times.

24.3.4 Input Disable

The pin inputs can be disabled on a port-by-port basis. The input of pins configured using the normal `MODEn` settings can be disabled by setting `DINDIS` in `GPIO_Px_CTRL`. The input of pins configured using the alternate `MODEn` settings can be disabled by setting `DINDISALT`.

24.3.5 Configuration Lock

The GPIO configuration registers (`GPIO_Px_CTRL`, `PIO_Px_MODEL`, `GPIO_xBUSALLOC`, `GPIO_EXTIPSELL`, `GPIO_EXTIPINSEL`, `GPIO_x_yROUTE`, and `GPIO_xROUTEEN`) can be locked by writing any value other than `0xA534` to `GPIO_LOCK`. Writing the value `0xA534` to the `GPIOx_LOCK` register unlocks the configuration registers.

24.3.6 EM2 Functionality

While all GPIO pins retain their state in EM2, only pins on port A and B remain fully functional in EM2. Digital peripherals which are active in EM2 must have their resources routed to pins on port A or B to function correctly in EM2. Analog peripherals may use any GPIO pin while in EM2 provided that the ABUS was configured prior to entering EM2. However, analog peripherals that are configured to scan multiple pins while in EM2 (such as the ADC) dynamically reconfigure the ABUS while in EM2 and thus must use only pins on port A and B.

24.3.7 EM4 Functionality

By default GPIO pins revert back to their reset state when EM4 is entered. The GPIO pins can be configured to retain the settings for output enable, output value, pull enable, and pull direction while in EM4.

EM4 GPIO retention is controlled with the `EM4IORETMODE` field in the `EMU_EM4CTRL` register:

- Setting `EM4IORETMODE` to `EM4EXIT` will cause GPIO retention to persist while in EM4. GPIO state will be reset during wakeup.
- Setting `EM4IORETMODE` to `SWUNLATCH` will cause the GPIO retention to persist through EM4 and wakeup, until the `EM4UNLATCH` bit is written by software. When using `SWUNLATCH`, the GPIO register values are still reset on wakeup. To ensure the GPIO state does not change, software must re-write the GPIO registers before setting `EM4UNLATCH` and ending EM4 GPIO retention. Note that the GPIO state cannot be retained through an EM4 wakeup due to a reset (e.g., pin reset or POR reset) - only non-reset methods of EM4 wakeup are supported (e.g., `EM4WU` IRQ or `BURTC` IRQ).

See the EMU chapter for additional documentation on `EM4IORETMODE` and the `EM4UNLATCH` bit.

24.3.8 EM4 Wakeup

It is possible to trigger a wake-up from EM4 using any of the selectable EM4WU GPIO pins. The wake-up request can be triggered through the pins by enabling the corresponding bit in the GPIO_EM4WUEN register. When EM4 wake-up is enabled for the pin, the input filter is enabled during EM4. This is done to avoid false wake-up caused by glitches. In addition, the polarity of the EM4 wake-up request can be selected using the GPIO_EM4WUPOL register.

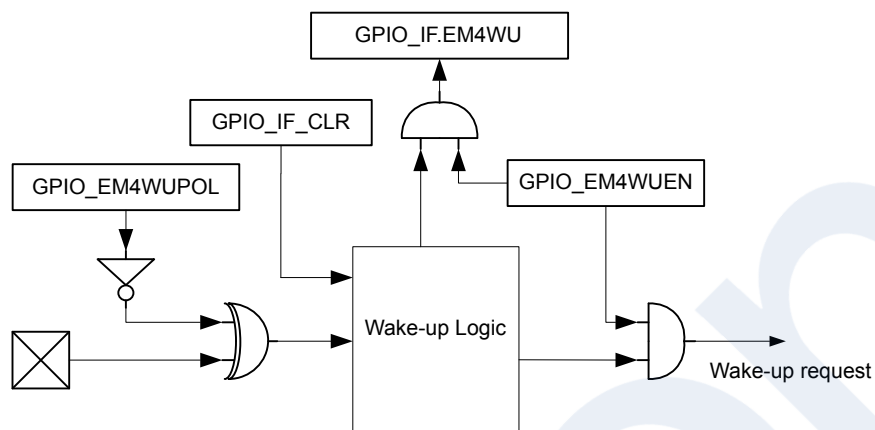

Figure 24.5. EM4 Wake-up Logic

The pins used for EM4 wake-up must be configured as inputs with glitch filters using the GPIO_Px_MODEL register. If the input is disabled and the wakeup polarity is low, a false wakeup will occur when entering EM4. If the input is enabled, the glitch filtered is disabled, and the polarity is set low, a glitch will occur when going into EM4 that will cause an immediate wake-up. Before going down to EM4, it is important to clear the wake-up logic by setting the GPIO_IF_CLR bits, which clear the wake-up logic, including the GPIO_IF register. It is possible to determine which pin caused the EM4WU by reading the GPIO_IF register.

Each EM4WU signal is connected to a fixed pin. Refer to the Alternate Function Table in the device Datasheet for the location of each EM4 wakeup signal.

24.3.9 Debug Connections

24.3.9.1 JTAG Debug Connection

The JTAG Debug Port is a fixed location resource connected directly to specific GPIO pins. Refer to the Alternate Function Table in the device Datasheet for the location of the JTAG signals. By default TMS, TCK, TDO, and TDI pin connections are enabled with internal pull up, pull down, no pull, and pull up resistors, respectively. It is possible to disable these pin connections (and disable the pull resistors) by setting the SWDIOTMSPEN, SWCLKTCKPEN, TDOPEN, and TDIPEN bits in GPIO_DEBUGROUTEPEN to 0.

24.3.9.2 Serial Wire Debug Connection

The SW Debug Port is a fixed location resource connected directly to specific GPIO pins. Refer to the Alternate Function Table in the device Datasheet for the location of the SW Debug port signals. The SWDIO and SWCLK pin connections are enabled by default with internal pull up and pull down resistors, respectively. It is possible to disable these pin connections (and disable the pull resistors) by setting the SWDIOTMSPEN and SWCLKTCKPEN bits in GPIO_DEBUGROUTEPEN to 0.

The Serial Wire Viewer pin, SWV, can be enabled by setting the SWVPEN bit in GPIO_TRACEROUTEPEN.

Note: The SWV pin is not affected by debug lock, so the SWV pin should not be enabled for production devices.

24.3.9.3 Disabling Debug Connections

When the debug pins are disabled, the device can no longer be accessed by a debugger. A reset will set the debug pins back to their enabled default state. The GPIO_DBGROUTEPEN register can only be updated when the debugger is disconnected from the system. Any attempts to modify GPIO_DBGROUTEPEN when the debugger is connected will not occur. If you do disable the debug pins, make sure you have at least a 3 second timeout at the start of your program code before you disable the debug pins. This way the debugger will have time to connect to the device after a reset and before the pins are disabled.

24.3.9.4 ETM Trace Connections

The device includes ETM trace pins. The trace clock can be enabled by setting the TRACECLKPEN bit-field in GPIO_TRACEROUTEPEN. The data pin(s) can be enabled individually by setting TRACEDATAxPEN in GPIO_TRACEROUTEPEN. The trace pins are fixed location resources connected to specific pins. Refer to the Alternate Function Table in the device Datasheet for the location of the ETM trace port signals.

24.3.10 Interrupt Generation

24.3.10.1 Standard Interrupt Generation

The GPIO can generate an interrupt from any edge of the input of any GPIO pin on the device. The standard interrupts have asynchronous sense capability, enabling wake-up from energy modes as low as EM3, see [Figure 24.6 Pin n Interrupt Generation on page 814](#).

Note: In EM2 and EM3, only signals on Port A and Port B are available as standard interrupts. Standard interrupts are available to all pins in EM0 and EM1.

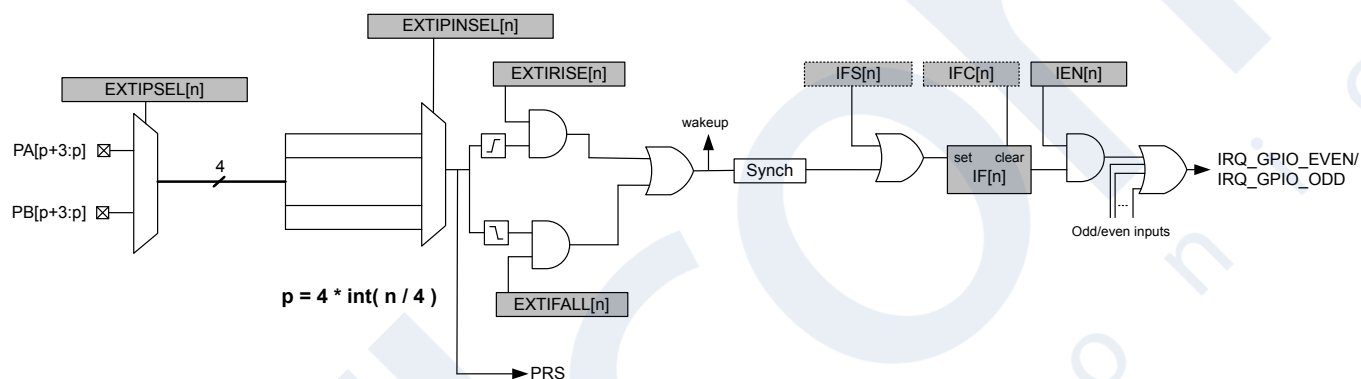

Figure 24.6. Pin n Interrupt Generation

The standard external pin interrupts are numbered starting with 0. Each interrupt has a corresponding enable bit in the GPIO_IEN register and an interrupt flag bit in the GPIO_IF register. Each interrupt may be used with one of four possible pins on any available port. First select the desired port for each interrupt using the corresponding EXTIPSELx field in the GPIO_EXTIPSELL register. (Some devices with many pins may also have a GPIO_EXTIPSELH register.)

Each interrupt can be mapped to one of four possible pins on the selected port. External interrupts EXTI0 through EXTI3 may be mapped to pins 0,1,2, or 3 on any available port. External interrupts EXTI4 through EXTI7 may be mapped to pins 4,5,6 or 7 on any available port.

Note: Note that while the EXTIEN field in the GPIO_IEN register has 15 bits, the number of useful bits is limited by the number of pins available in the widest port. If the widest port is 8 bits wide, only the first 8 external interrupts are useful.

The selected pin for each interrupt is the base plus the offset. The base for EXTI0 through EXTI3 is 0, while the base for interrupts EXTI4 through EXTI7 is 4. The base may be calculated by taking the interrupt number, dividing by four, then using only the integer portion of the quotient. (BASE = Integer(N/4)

The offset is selected using the corresponding field in the GPIO_EXTIPINSELL register, (Some devices with many pins may also have a GPIO_EXTIPINSELH register.) Subtract the base from the desired pin number to get the offset. For example, to map EXTI5 to pin 7 of PORTA, the base is 4 and the offset will be 3.

The GPIO_EXTIRISE[n] and GPIO_EXTIFALL[n] registers enable sensing of rising and falling edges. By setting the EXT[n] bit in GPIO_IEN, a high interrupt flag n, will trigger one of two interrupt lines. The even interrupt line is triggered by any enabled even numbered interrupt flag index, while the odd interrupt line is triggered by odd flag indexes. The interrupt flags can be set and cleared by software when writing the GPIO_IF_SET and GPIO_IF_CLR register locations. Since the external interrupts are asynchronous, they are sensitive to noise. To increase noise tolerance, the MODEx field(s) in the GPIO_Px_MODEL register, should be set to include glitch filtering for pins that have external interrupts enabled.

24.3.10.2 Interrupt Generation on EM4WU Pins

In addition to being an EM4 wake source, any of the dedicated EM4WU (EM4 wake-up) signals on PA, PB, PC or PD may be used to generate edge-sensitive interrupts in EM0, EM1, EM2, and EM3.

In order to enable an EM4WU pin as an interrupt, set the EM4WUIENn field in the GPIO_IEN register and the EM4WUENn field in the EM4WUEN register. The EM4WUPOLn field in the GPIO_EM4WUPOL register is used to set the desired polarity for the interrupt (0 for a falling edge, and 1 for a rising edge).

Upon an interrupt occurring, the corresponding EM4WU index in the GPIO_IF register will be set along with the odd or even interrupt line depending on the index inside of GPIO_IF. For example, by setting the EM4WU8 in GPIO_EM4WUPOL and EM4WU[8] in GPIO_IEN, the interrupt flag EM4WU[8] in GPIO_IF will be triggered by a rising edge on pin EM4WU8 and a interrupt request will be sent on IRQ_GPIO_EVEN.

The wake-up granularity of the EM4WU interrupts is based on the settings of the EM4WU field in the GPIO_IEN register and the EM4WUEN field in the GPIO_EM4WUEN register (see [Table 24.2 EM4WU Interrupt Energy Mode Wakeup on page 815](#)).

Table 24.2. EM4WU Interrupt Energy Mode Wakeup

EM4WUIENn in GPIO_IEN	EM4WUENn in GPIO_EM4WUEN	Energy Mode Wakeup	Interrupt
x	0	No Wake	No Interrupt
0	1	Wake from EM4	No Interrupt
1	1	Wake from EM1, EM2, EM3, or EM4	Interrupt from EM0, EM1, EM2, or EM3

For example, to configure the device to wake up and generate an interrupt when PD02 (EM4WU9) sees a falling edge:

1. Set bit 9 of EM4WUEN in the GPIO_EM4WUEN register to '1'. This enables the asynchronous wake logic.
2. Set bit 9 of EM4WUIEN in the GPIO_IEN register to '1'. This enables routing of the wake signal to the GPIO_ODD IRQ.
3. Clear bit 9 of EM4WUPOL in the GPIO_EM4WUPOL register to '0'. This indicates that the interrupt should occur when a falling edge is detected at the pin.
4. Enable the GPIO.ODD IRQ. The ODD interrupt is used because the bit index of EM4WUIF in GPIO_IF is odd.

24.3.11 Output to PRS

All pins within a group of four(0-3,4-7,8-11,12-15) from all ports are grouped together to form one PRS producer which outputs to the PRS. The pin from which the output should be taken is selected in the same fashion as the edge interrupts.

PRS output is not affected by the interrupt edge detection logic or gated by the IEN bits. See [24.3.10 Interrupt Generation](#) for an illustration of where the PRS output signal is generated.

24.3.12 Peripheral Resource Routing

Most peripherals have resources that need to be connected to GPIO pins to function. For example, the I2C has SDA and SCL which need to be connected to pins for the I2C to communicate with other ICs. Resources come in three types. Fixed resources are hard-wired to a pin and can only be accessed in that location. For example the LFXO LFX TAL_I and LFX TAL_O resources are only available on one pin each. Digital route-able resources are connected to pins through the [24.3.12.1 Digital Bus \(DBUS\)](#) which allows for extremely flexible resource placement. Analog route-able resources are connected to pins through the [24.3.12.2 Analog Bus \(ABUS\)](#) which provides extremely flexible resource placement.

The locations of fixed resources and the limitations of ABUS and DBUS on each device can be found in the device data sheet.

24.3.12.1 Digital Bus (DBUS)

The Digital Bus (DBUS) is an any-to-any switch matrix between peripheral resources and GPIO pins as shown in [Figure 24.7 Digital Bus Interconnect on page 816](#). There are two DBUSes on the EFR32xG24 - DBUSAB serves ports A and B, while DBUSCD serves ports C and D. Not all peripherals have access to both DBUSes.

To connect a resource to a pin, first select the desired PORT and PIN in the GPIO_x_yROUTE register, where x is the peripheral name and y is the resource name. The PORT field is encoded as PA = 0, PB = 1, PC = 2, etc. Once the pin is selected, the resource must be enabled by setting its enable bit in the appropriate GPIO_x_ROUTEEN register. For example, to route the SDA resource of I2C0 to PB03, set PORT to 0x1 and PIN to 0x3 in GPIO_I2C0_SDAROUTE. Then set the GPIO_I2C0_ROUTEN.SDAPEN bit.

Any pin connected to a digital resource should be properly configured for that resource (refer to [24.3.1 Pin Configuration](#)). For example, an I2C SDA should be configured as open-drain, a USART (or EUSART) TX should be configured as push-pull, and a USART (or EUSART) RX should be configured as an input.

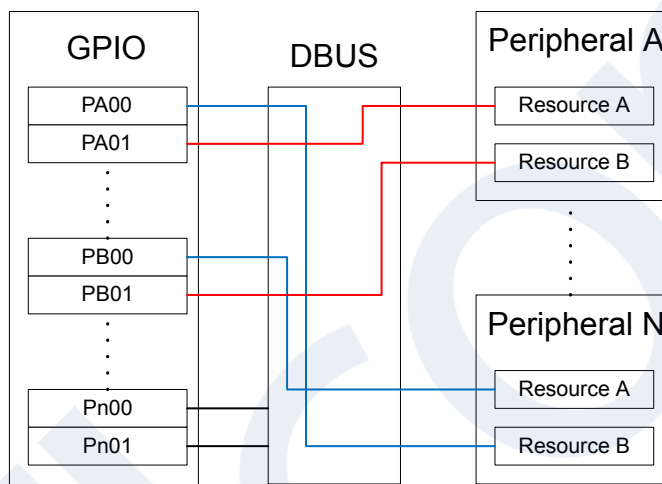

Figure 24.7. Digital Bus Interconnect

24.3.12.2 Analog Bus (ABUS)

Analog peripherals may be connected to any pins on port A, B, C, or D via the Analog Bus. There are three analog buses on the EFR32xG24: one dedicated to Port A (ABUSA), one dedicated to port B (ABUSB), and one that serves both ports C and D (ABUSCD). The specific pin and port selection for analog resources are configured in the analog peripherals. Refer to the respective analog peripheral chapter for this information. However, the GPIO block must be configured to grant the peripheral access to an ABUS before any connection can be made.

Note: The analog signals on ABUSes will be voltage limited by the lowest supply voltage of IOVDD and AVDD.

Up to two analog peripherals may be given access to an ABUS at any one time and the even/odd pins of each bus are configured independently. This means that a single bus may have up to four different analog peripherals connected to it: two on the even pins and two on the odd pins. The GPIO_ABUSxALLOC register, where x is the port, determines which peripherals have access to the bus. To grant a peripheral access to the bus even pins select it in either the EVEN0 or EVEN1 field. To grant a peripheral access to the bus odd pins select it in either the ODD0 or ODD1 fields.

When a differential connection is being used, positive inputs are restricted to the EVEN pins and negative inputs are restricted to the ODD pins. When a single ended connection is being used, the positive input is available on all pins.

Peripherals may be given access to as many buses as desired. For example the ADC may be given access to ABUSA, ABUSB, and ABUSCD allowing it to select any pin on ports A-D. If two peripherals select the same port and pin the ABUS will make both connections simultaneously, effectively connecting the two peripherals together.

Any pin connected to an analog resource should be configured to input DISABLED as described in [24.3.1 Pin Configuration](#)

The process for configuring an analog peripheral to access a pin through the ABUS is as follows:

- Configure the desired analog port pins to input DISABLED mode in the corresponding GPIO_PORTx_MODEL/H register.
- Configure the corresponding GPIO_xBUSALLOC field to grant access to the desired peripheral on the desired ABUS.
- Configure the analog peripheral to select the desired port and channel as described in the peripheral chapter.

24.3.12.3 Pin Function Tables

This section details the functions and GPIO pins available on the most fully-featured devices in the EFR32xG24 family. Availability of GPIO and signals varies. Refer to the device datasheet for specific peripheral and GPIO availability. Fixed-pin peripheral resources are shown in [Table 24.3 GPIO Alternate Function Table on page 818](#), ABUS routing options are listed in [Table 24.4 ABUS Routing Table on page 819](#), and DBUS routing options are listed in [Table 24.5 DBUS Routing Table on page 820](#)

Table 24.3. GPIO Alternate Function Table

GPIO	Alternate Functions	QFN48 / Standard Package	QFN48 / ADC Package	WLCSP42 Package	QFN40 / Standard Package	QFN40 / HFCLKOUT Package
PA00	IADC0.VREFP				Yes	Yes
PA01	GPIO.SWCLK	Yes	Yes	Yes	Yes	Yes
PA02	GPIO.SWDIO	Yes	Yes	Yes	Yes	Yes
PA03	GPIO.SWV	Yes	Yes	Yes	Yes	Yes
	GPIO.TDO	Yes	Yes	Yes	Yes	Yes
	GPIO.TRACEDATA0	Yes	Yes	Yes	Yes	Yes
PA04	GPIO.TDI	Yes	Yes	Yes	Yes	Yes
	GPIO.TRACECLK	Yes	Yes	Yes	Yes	Yes
PA05	GPIO.TRACEDATA1	Yes	Yes	Yes	Yes	Yes
	GPIO.EM4WU0	Yes	Yes	Yes	Yes	Yes
PA06	GPIO.TRACEDATA2	Yes	Yes	Yes	Yes	Yes
PA07	GPIO.TRACEDATA3	Yes	Yes	Yes	Yes	Yes
PB00	VDAC0.CH0_MAIN_OUT	Yes	Yes	Yes	Yes	Yes
PB01	GPIO.EM4WU3	Yes	Yes	Yes	Yes	Yes
	VDAC0.CH1_MAIN_OUT	Yes	Yes	Yes	Yes	Yes
PB02	VDAC1.CH0_MAIN_OUT	Yes	Yes		Yes	Yes
PB03	GPIO.EM4WU4	Yes	Yes	Yes	Yes	Yes
	VDAC1.CH1_MAIN_OUT	Yes	Yes	Yes	Yes	Yes
PC00	GPIO.EM4WU6	Yes	Yes		Yes	Yes
PC01	GPIO.EFP_TX_SDA	Yes	Yes	Yes	Yes	Yes
PC02	GPIO.EFP_TX_SCL	Yes	Yes	Yes	Yes	Yes
PC05	GPIO.EFP_INT	Yes	Yes	Yes	Yes	Yes
	GPIO.EM4WU7	Yes	Yes	Yes	Yes	Yes
PC06	GPIO.THMSW_EN					Yes
	GPIO.THMSW_HALFSWITCH					Yes
PC07	GPIO.EM4WU8	Yes	Yes		Yes	
	GPIO.THMSW_EN				Yes	
	GPIO.THMSW_HALFSWITCH				Yes	
PC09	GPIO.THMSW_EN	Yes	Yes	Yes		
	GPIO.THMSW_HALFSWITCH	Yes	Yes	Yes		

GPIO	Alternate Functions	QFN48 / Standard Package	QFN48 / ADC Package	WLCSP42 Package	QFN40 / Standard Package	QFN40 / HFCLKOUT Package
PD00	LFXO.LFXTAL_O	Yes	Yes	Yes	Yes	Yes
PD01	LFXO.LFXTAL_I	Yes	Yes	Yes	Yes	Yes
	LFXO.LF_EXTCLK	Yes	Yes	Yes	Yes	Yes
PD02	GPIO.EM4WU9	Yes	Yes		Yes	Yes
PD05	GPIO.EM4WU10	Yes	Yes	Yes		

Table 24.4. ABUS Routing Table

Peripheral	Signal	PA		PB		PC		PD	
		EVEN	ODD	EVEN	ODD	EVEN	ODD	EVEN	ODD
ACMP0	ana_neg	Yes	Yes	Yes	Yes	Yes	Yes	Yes	Yes
	ana_pos	Yes	Yes	Yes	Yes	Yes	Yes	Yes	Yes
ACMP1	ana_neg	Yes	Yes	Yes	Yes	Yes	Yes	Yes	Yes
	ana_pos	Yes	Yes	Yes	Yes	Yes	Yes	Yes	Yes
IADC0	ana_neg	Yes	Yes	Yes	Yes	Yes	Yes	Yes	Yes
	ana_pos	Yes	Yes	Yes	Yes	Yes	Yes	Yes	Yes
VDAC0	ch0_abus_out	Yes	Yes	Yes	Yes	Yes	Yes	Yes	Yes
	ch1_abus_out	Yes	Yes	Yes	Yes	Yes	Yes	Yes	Yes
VDAC1	ch0_abus_out	Yes	Yes	Yes	Yes	Yes	Yes	Yes	Yes
	ch1_abus_out	Yes	Yes	Yes	Yes	Yes	Yes	Yes	Yes

Table 24.5. DBUS Routing Table

Peripheral.Resource	PORT			
	PA	PB	PC	PD
ACMP0.DIGOUT	Available	Available	Available	Available
ACMP1.DIGOUT	Available	Available	Available	Available
CMU.CLKIN0			Available	Available
CMU.CLKOUT0			Available	Available
CMU.CLKOUT1			Available	Available
CMU.CLKOUT2	Available	Available		
EUSART0.CS	Available	Available		
EUSART0.CTS	Available	Available		
EUSART0.RTS	Available	Available		
EUSART0.RX	Available	Available		
EUSART0.SCLK	Available	Available		
EUSART0.TX	Available	Available		
EUSART1.CS	Available	Available	Available	Available
EUSART1.CTS	Available	Available	Available	Available
EUSART1.RTS	Available	Available	Available	Available
EUSART1.RX	Available	Available	Available	Available
EUSART1.SCLK	Available	Available	Available	Available
EUSART1.TX	Available	Available	Available	Available
FRC.DCLK			Available	Available
FRC.DFRAME			Available	Available
FRC.DOUT			Available	Available
HFXO0.BUFOUT_REQ_IN_ASYNC	Available	Available		
I2C0.SCL	Available	Available	Available	Available
I2C0.SDA	Available	Available	Available	Available
I2C1.SCL			Available	Available
I2C1.SDA			Available	Available
KEYSCAN.COL_OUT_0	Available	Available	Available	Available
KEYSCAN.COL_OUT_1	Available	Available	Available	Available
KEYSCAN.COL_OUT_2	Available	Available	Available	Available
KEYSCAN.COL_OUT_3	Available	Available	Available	Available
KEYSCAN.COL_OUT_4	Available	Available	Available	Available
KEYSCAN.COL_OUT_5	Available	Available	Available	Available
KEYSCAN.COL_OUT_6	Available	Available	Available	Available
KEYSCAN.COL_OUT_7	Available	Available	Available	Available

Peripheral.Resource	PORT			
	PA	PB	PC	PD
KEYSCAN.ROW_SENSE_0	Available	Available		
KEYSCAN.ROW_SENSE_1	Available	Available		
KEYSCAN.ROW_SENSE_2	Available	Available		
KEYSCAN.ROW_SENSE_3	Available	Available		
KEYSCAN.ROW_SENSE_4	Available	Available		
KEYSCAN.ROW_SENSE_5	Available	Available		
LETIMER0.OUT0	Available	Available		
LETIMER0.OUT1	Available	Available		
MODEM.ANT0	Available	Available	Available	Available
MODEM.ANT1	Available	Available	Available	Available
MODEM.ANT_ROLL_OVER			Available	Available
MODEM.ANT_RR0			Available	Available
MODEM.ANT_RR1			Available	Available
MODEM.ANT_RR2			Available	Available
MODEM.ANT_RR3			Available	Available
MODEM.ANT_RR4			Available	Available
MODEM.ANT_RR5			Available	Available
MODEM.ANT_SW_EN			Available	Available
MODEM.ANT_SW_US			Available	Available
MODEM.ANT_TRIG			Available	Available
MODEM.ANT_TRIG_STOP			Available	Available
MODEM.DCLK	Available	Available		
MODEM.DIN	Available	Available		
MODEM.DOUT	Available	Available		
PCNT0.S0IN	Available	Available		
PCNT0.S1IN	Available	Available		
PRS.ASYNCH0	Available	Available		
PRS.ASYNCH1	Available	Available		
PRS.ASYNCH10			Available	Available
PRS.ASYNCH11			Available	Available
PRS.ASYNCH12	Available	Available		
PRS.ASYNCH13	Available	Available		
PRS.ASYNCH14	Available	Available		
PRS.ASYNCH15	Available	Available		
PRS.ASYNCH2	Available	Available		
PRS.ASYNCH3	Available	Available		

Peripheral.Resource	PORT			
	PA	PB	PC	PD
PRS.ASYNCH4	Available	Available		
PRS.ASYNCH5	Available	Available		
PRS.ASYNCH6			Available	Available
PRS.ASYNCH7			Available	Available
PRS.ASYNCH8			Available	Available
PRS.ASYNCH9			Available	Available
PRS.SYNCH0	Available	Available	Available	Available
PRS.SYNCH1	Available	Available	Available	Available
PRS.SYNCH2	Available	Available	Available	Available
PRS.SYNCH3	Available	Available	Available	Available
RAC.LNAEN	Available	Available	Available	Available
RAC.PAEN	Available	Available	Available	Available
TIMER0.CC0	Available	Available	Available	Available
TIMER0.CC1	Available	Available	Available	Available
TIMER0.CC2	Available	Available	Available	Available
TIMER0.CDTI0	Available	Available	Available	Available
TIMER0.CDTI1	Available	Available	Available	Available
TIMER0.CDTI2	Available	Available	Available	Available
TIMER1.CC0	Available	Available	Available	Available
TIMER1.CC1	Available	Available	Available	Available
TIMER1.CC2	Available	Available	Available	Available
TIMER1.CDTI0	Available	Available	Available	Available
TIMER1.CDTI1	Available	Available	Available	Available
TIMER1.CDTI2	Available	Available	Available	Available
TIMER2.CC0	Available	Available		
TIMER2.CC1	Available	Available		
TIMER2.CC2	Available	Available		
TIMER2.CDTI0	Available	Available		
TIMER2.CDTI1	Available	Available		
TIMER2.CDTI2	Available	Available		
TIMER3.CC0			Available	Available
TIMER3.CC1			Available	Available
TIMER3.CC2			Available	Available
TIMER3.CDTI0			Available	Available
TIMER3.CDTI1			Available	Available
TIMER3.CDTI2			Available	Available

Peripheral.Resource	PORT			
	PA	PB	PC	PD
TIMER4.CC0	Available	Available		
TIMER4.CC1	Available	Available		
TIMER4.CC2	Available	Available		
TIMER4.CDTI0	Available	Available		
TIMER4.CDTI1	Available	Available		
TIMER4.CDTI2	Available	Available		
USART0.CLK	Available	Available	Available	Available
USART0.CS	Available	Available	Available	Available
USART0.CTS	Available	Available	Available	Available
USART0.RTS	Available	Available	Available	Available
USART0.RX	Available	Available	Available	Available
USART0.TX	Available	Available	Available	Available

24.4 Synchronization

To avoid metastability in synchronous logic connected to the pins, all inputs are synchronized with double flip-flops. The flip-flops for the input data run on the selected APB clock for the GPIO module (PCLK). Consequently, when a pin changes state, the change will propagate to GPIO_Px_DIN after two 2 PCLK cycles. Synchronization (also running on the PCLK) is also added for interrupt input. To save power when the external interrupts are not used, the synchronization flip-flops for these can be turned off by clearing the EXTINT field in the GPIO_IEN register.

24.5 GPIO Register Map

The offset register address is relative to the registers base address.

Offset	Name	Type	Description
0x000	GPIO_IPVERSION	R	Main
0x030	GPIO_PORTA_CTRL	RW	Port Control
0x034	GPIO_PORTA_MODEL	RW	Mode Low
0x03C	GPIO_PORTA_MODEH	RW	Mode High
0x040	GPIO_PORTA_DOUT	RW	Data Out
0x044	GPIO_PORTA_DIN	RH	Data in
0x060	GPIO_PORTB_CTRL	RW	Port Control
0x064	GPIO_PORTB_MODEL	RW	Mode Low
0x070	GPIO_PORTB_DOUT	RW	Data Out
0x074	GPIO_PORTB_DIN	RH	Data in
0x090	GPIO_PORTC_CTRL	RW	Port Control
0x094	GPIO_PORTC_MODEL	RW	Mode Low
0x09C	GPIO_PORTC_MODEH	RW	Mode High
0x0A0	GPIO_PORTC_DOUT	RW	Data Out
0x0A4	GPIO_PORTC_DIN	RH	Data in
0x0C0	GPIO_PORTD_CTRL	RW	Port Control
0x0C4	GPIO_PORTD_MODEL	RW	Mode Low
0x0D0	GPIO_PORTD_DOUT	RW	Data Out
0x0D4	GPIO_PORTD_DIN	RH	Data in
0x300	GPIO_LOCK	W	Lock Register
0x310	GPIO_GPIOLOCKSTATUS	RH	Lock Status
0x320	GPIO_ABUSALLOC	RW	A Bus Allocation
0x324	GPIO_BBUSALLOC	RW	B Bus Allocation
0x328	GPIO_CDBUSALLOC	RW	CD Bus Allocation
0x400	GPIO_EXTIPSELL	RW	External Interrupt Port Select Low
0x404	GPIO_EXTIPSELH	RW	External Interrupt Port Select High
0x408	GPIO_EXTIPINSELL	RW	External Interrupt Pin Select Low
0x40C	GPIO_EXTIPINSELH	RW	External Interrupt Pin Select High
0x410	GPIO_EXTIRISE	RW	External Interrupt Rising Edge Trigger
0x414	GPIO_EXTIFALL	RW	External Interrupt Falling Edge Trigger
0x420	GPIO_IF	RWH INTFLAG	Interrupt Flag
0x424	GPIO_IEN	RW	Interrupt Enable
0x42C	GPIO_EM4WUEN	RW	EM4 Wakeup Enable
0x430	GPIO_EM4WUPOL	RW	EM4 Wakeup Polarity
0x440	GPIO_DBGROUPEPEN	RW	Debugger Route Pin Enable

Offset	Name	Type	Description
0x444	GPIO_TRACEROUTEPEN	RW	Trace Route Pin Enable
0x450	GPIO_ACMP0_ROUTEEN	RW	ACMP0 Pin Enable
0x454	GPIO_ACMP0_ACMPOUT-ROUTE	RW	ACMPOUT Port/Pin Select
0x45C	GPIO_ACMP1_ROUTEEN	RW	ACMP1 Pin Enable
0x460	GPIO_ACMP1_ACMPOUT-ROUTE	RW	ACMPOUT Port/Pin Select
0x468	GPIO_CMU_ROUTEEN	RW	CMU Pin Enable
0x46C	GPIO_CMU_CLKIN0ROUTE	RW	CLKIN0 Port/Pin Select
0x470	GPIO_CMU_CLKOUT0ROUTE	RW	CLKOUT0 Port/Pin Select
0x474	GPIO_CMU_CLKOUT1ROUTE	RW	CLKOUT1 Port/Pin Select
0x478	GPIO_CMU_CLKOUT2ROUTE	RW	CLKOUT2 Port/Pin Select
0x494	GPIO_EUSART0_ROUTEEN	RW	EUSART0 Pin Enable
0x498	GPIO_EUSART0_CSROUTE	RW	CS Port/Pin Select
0x49C	GPIO_EUSART0_CTSROUTE	RW	CTS Port/Pin Select
0x4A0	GPIO_EUSART0_RTSMROUTE	RW	RTS Port/Pin Select
0x4A4	GPIO_EUSART0_RXROUTE	RW	RX Port/Pin Select
0x4A8	GPIO_EUSART0_SCLKROUTE	RW	SCLK Port/Pin Select
0x4AC	GPIO_EUSART0_TXROUTE	RW	TX Port/Pin Select
0x4B4	GPIO_EUSART1_ROUTEEN	RW	EUSART1 Pin Enable
0x4B8	GPIO_EUSART1_CSROUTE	RW	CS Port/Pin Select
0x4BC	GPIO_EUSART1_CTSROUTE	RW	CTS Port/Pin Select
0x4C0	GPIO_EUSART1_RTSMROUTE	RW	RTS Port/Pin Select
0x4C4	GPIO_EUSART1_RXROUTE	RW	RX Port/Pin Select
0x4C8	GPIO_EUSART1_SCLKROUTE	RW	SCLK Port/Pin Select
0x4CC	GPIO_EUSART1_TXROUTE	RW	TX Port/Pin Select
0x4D4	GPIO_FRC_ROUTEEN	RW	FRC Pin Enable
0x4D8	GPIO_FRC_DCLKROUTE	RW	DCLK Port/Pin Select
0x4DC	GPIO_FRC_DFRAMERROUTE	RW	DFRAME Port/Pin Select
0x4E0	GPIO_FRC_DOUTROUTE	RW	DOUT Port/Pin Select
0x4E8	GPIO_I2C0_ROUTEEN	RW	I2C0 Pin Enable
0x4EC	GPIO_I2C0_SCLROUTE	RW	SCL Port/Pin Select
0x4F0	GPIO_I2C0_SDARROUTE	RW	SDA Port/Pin Select
0x4F8	GPIO_I2C1_ROUTEEN	RW	I2C1 Pin Enable
0x4FC	GPIO_I2C1_SCLROUTE	RW	SCL Port/Pin Select
0x500	GPIO_I2C1_SDARROUTE	RW	SDA Port/Pin Select
0x508	GPIO_KEYSCAN_ROUTEEN	RW	KEYSCAN Pin Enable

Offset	Name	Type	Description
0x50C	GPIO_KEYSCAN_COL-OUT0ROUTE	RW	COLOUT0 Port/Pin Select
0x510	GPIO_KEYSCAN_COL-OUT1ROUTE	RW	COLOUT1 Port/Pin Select
0x514	GPIO_KEYSCAN_COL-OUT2ROUTE	RW	COLOUT2 Port/Pin Select
0x518	GPIO_KEYSCAN_COL-OUT3ROUTE	RW	COLOUT3 Port/Pin Select
0x51C	GPIO_KEYSCAN_COL-OUT4ROUTE	RW	COLOUT4 Port/Pin Select
0x520	GPIO_KEYSCAN_COL-OUT5ROUTE	RW	COLOUT5 Port/Pin Select
0x524	GPIO_KEYSCAN_COL-OUT6ROUTE	RW	COLOUT6 Port/Pin Select
0x528	GPIO_KEYSCAN_COL-OUT7ROUTE	RW	COLOUT7 Port/Pin Select
0x52C	GPIO_KEYSCAN_ROW-SENSE0ROUTE	RW	ROWSENSE0 Port/Pin Select
0x530	GPIO_KEYSCAN_ROW-SENSE1ROUTE	RW	ROWSENSE1 Port/Pin Select
0x534	GPIO_KEYSCAN_ROW-SENSE2ROUTE	RW	ROWSENSE2 Port/Pin Select
0x538	GPIO_KEYSCAN_ROW-SENSE3ROUTE	RW	ROWSENSE3 Port/Pin Select
0x53C	GPIO_KEYSCAN_ROW-SENSE4ROUTE	RW	ROWSENSE4 Port/Pin Select
0x540	GPIO_KEYSCAN_ROW-SENSE5ROUTE	RW	ROWSENSE5 Port/Pin Select
0x548	GPIO_LETIMER_ROUTEEN	RW	LETIMER Pin Enable
0x54C	GPIO_LETIMER_OUT0ROUTE	RW	OUT0 Port/Pin Select
0x550	GPIO_LETIMER_OUT1ROUTE	RW	OUT1 Port/Pin Select
0x558	GPIO_MODEM_ROUTEEN	RW	MODEM Pin Enable
0x55C	GPIO_MODEM_ANT0ROUTE	RW	ANT0 Port/Pin Select
0x560	GPIO_MODEM_ANT1ROUTE	RW	ANT1 Port/Pin Select
0x564	GPIO_MODEM_ANTROLLOVERROUTE	RW	ANTROLLOVER Port/Pin Select
0x568	GPIO_MODEM_ANTRR0ROUTE	RW	ANTRR0 Port/Pin Select
0x56C	GPIO_MODEM_ANTRR1ROUTE	RW	ANTRR1 Port/Pin Select
0x570	GPIO_MODEM_ANTRR2ROUTE	RW	ANTRR2 Port/Pin Select
0x574	GPIO_MODEM_ANTRR3ROUTE	RW	ANTRR3 Port/Pin Select

Offset	Name	Type	Description
0x578	GPIO_MO- DEM_ANTRR4ROUTE	RW	ANTRR4 Port/Pin Select
0x57C	GPIO_MO- DEM_ANTRR5ROUTE	RW	ANTRR5 Port/Pin Select
0x580	GPIO_MODEM_ANTSWEN- ROUTE	RW	ANTSWEN Port/Pin Select
0x584	GPIO_MODEM_ANTSWUS- ROUTE	RW	ANTSWUS Port/Pin Select
0x588	GPIO_MODEM_ANTTRIG- ROUTE	RW	ANTTRIG Port/Pin Select
0x58C	GPIO_MODEM_ANTTRIGSTOP- ROUTE	RW	ANTTRIGSTOP Port/Pin Select
0x590	GPIO_MODEM_DCLKROUTE	RW	DCLK Port/Pin Select
0x594	GPIO_MODEM_DINROUTE	RW	DIN Port/Pin Select
0x598	GPIO_MODEM_DOUTROUTE	RW	DOUT Port/Pin Select
0x5A4	GPIO_PCNT0_S0INROUTE	RW	S0IN Port/Pin Select
0x5A8	GPIO_PCNT0_S1INROUTE	RW	S1IN Port/Pin Select
0x5B0	GPIO_PRS0_ROUTEEN	RW	PRS0 Pin Enable
0x5B4	GPIO_PRS0_ASYNCH0ROUTE	RW	ASYNCH0 Port/Pin Select
0x5B8	GPIO_PRS0_ASYNCH1ROUTE	RW	ASYNCH1 Port/Pin Select
0x5BC	GPIO_PRS0_ASYNCH2ROUTE	RW	ASYNCH2 Port/Pin Select
0x5C0	GPIO_PRS0_ASYNCH3ROUTE	RW	ASYNCH3 Port/Pin Select
0x5C4	GPIO_PRS0_ASYNCH4ROUTE	RW	ASYNCH4 Port/Pin Select
0x5C8	GPIO_PRS0_ASYNCH5ROUTE	RW	ASYNCH5 Port/Pin Select
0x5CC	GPIO_PRS0_ASYNCH6ROUTE	RW	ASYNCH6 Port/Pin Select
0x5D0	GPIO_PRS0_ASYNCH7ROUTE	RW	ASYNCH7 Port/Pin Select
0x5D4	GPIO_PRS0_ASYNCH8ROUTE	RW	ASYNCH8 Port/Pin Select
0x5D8	GPIO_PRS0_ASYNCH9ROUTE	RW	ASYNCH9 Port/Pin Select
0x5DC	GPIO_PRS0_ASYNCH10ROUT E	RW	ASYNCH10 Port/Pin Select
0x5E0	GPIO_PRS0_ASYNCH11ROUT E	RW	ASYNCH11 Port/Pin Select
0x5E4	GPIO_PRS0_ASYNCH12ROUT E	RW	ASYNCH12 Port/Pin Select
0x5E8	GPIO_PRS0_ASYNCH13ROUT E	RW	ASYNCH13 Port/Pin Select
0x5EC	GPIO_PRS0_ASYNCH14ROUT E	RW	ASYNCH14 Port/Pin Select
0x5F0	GPIO_PRS0_ASYNCH15ROUT E	RW	ASYNCH15 Port/Pin Select
0x5F4	GPIO_PRS0_SYNCH0ROUTE	RW	SYNCH0 Port/Pin Select
0x5F8	GPIO_PRS0_SYNCH1ROUTE	RW	SYNCH1 Port/Pin Select

Offset	Name	Type	Description
0x5FC	GPIO_PRS0_SYNCH2ROUTE	RW	SYNCH2 Port/Pin Select
0x600	GPIO_PRS0_SYNCH3ROUTE	RW	SYNCH3 Port/Pin Select
0x608	GPIO_RAC_ROUTEEN	RW	RAC Pin Enable
0x60C	GPIO_RAC_LNAENROUTE	RW	LNAEN Port/Pin Select
0x610	GPIO_RAC_PAENROUTE	RW	PAEN Port/Pin Select
0x678	GPIO_SYXO0_BUFOUTREQUINASYNCROUTE	RW	BUFOUTREQUINASYNC Port/Pin Select
0x680	GPIO_TIMER0_ROUTEEN	RW	TIMER0 Pin Enable
0x684	GPIO_TIMER0_CC0ROUTE	RW	CC0 Port/Pin Select
0x688	GPIO_TIMER0_CC1ROUTE	RW	CC1 Port/Pin Select
0x68C	GPIO_TIMER0_CC2ROUTE	RW	CC2 Port/Pin Select
0x690	GPIO_TIMER0_CDTI0ROUTE	RW	CDTI0 Port/Pin Select
0x694	GPIO_TIMER0_CDTI1ROUTE	RW	CDTI1 Port/Pin Select
0x698	GPIO_TIMER0_CDTI2ROUTE	RW	CDTI2 Port/Pin Select
0x6A0	GPIO_TIMER1_ROUTEEN	RW	TIMER1 Pin Enable
0x6A4	GPIO_TIMER1_CC0ROUTE	RW	CC0 Port/Pin Select
0x6A8	GPIO_TIMER1_CC1ROUTE	RW	CC1 Port/Pin Select
0x6AC	GPIO_TIMER1_CC2ROUTE	RW	CC2 Port/Pin Select
0x6B0	GPIO_TIMER1_CDTI0ROUTE	RW	CDTI0 Port/Pin Select
0x6B4	GPIO_TIMER1_CDTI1ROUTE	RW	CDTI1 Port/Pin Select
0x6B8	GPIO_TIMER1_CDTI2ROUTE	RW	CDTI2 Port/Pin Select
0x6C0	GPIO_TIMER2_ROUTEEN	RW	TIMER2 Pin Enable
0x6C4	GPIO_TIMER2_CC0ROUTE	RW	CC0 Port/Pin Select
0x6C8	GPIO_TIMER2_CC1ROUTE	RW	CC1 Port/Pin Select
0x6CC	GPIO_TIMER2_CC2ROUTE	RW	CC2 Port/Pin Select
0x6D0	GPIO_TIMER2_CDTI0ROUTE	RW	CDTI0 Port/Pin Select
0x6D4	GPIO_TIMER2_CDTI1ROUTE	RW	CDTI1 Port/Pin Select
0x6D8	GPIO_TIMER2_CDTI2ROUTE	RW	CDTI2 Port/Pin Select
0x6E0	GPIO_TIMER3_ROUTEEN	RW	TIMER3 Pin Enable
0x6E4	GPIO_TIMER3_CC0ROUTE	RW	CC0 Port/Pin Select
0x6E8	GPIO_TIMER3_CC1ROUTE	RW	CC1 Port/Pin Select
0x6EC	GPIO_TIMER3_CC2ROUTE	RW	CC2 Port/Pin Select
0x6F0	GPIO_TIMER3_CDTI0ROUTE	RW	CDTI0 Port/Pin Select
0x6F4	GPIO_TIMER3_CDTI1ROUTE	RW	CDTI1 Port/Pin Select
0x6F8	GPIO_TIMER3_CDTI2ROUTE	RW	CDTI2 Port/Pin Select
0x700	GPIO_TIMER4_ROUTEEN	RW	TIMER4 Pin Enable
0x704	GPIO_TIMER4_CC0ROUTE	RW	CC0 Port/Pin Select

Offset	Name	Type	Description
0x708	GPIO_TIMER4_CC1ROUTE	RW	CC1 Port/Pin Select
0x70C	GPIO_TIMER4_CC2ROUTE	RW	CC2 Port/Pin Select
0x710	GPIO_TIMER4_CDTI0ROUTE	RW	CDTI0 Port/Pin Select
0x714	GPIO_TIMER4_CDTI1ROUTE	RW	CDTI1 Port/Pin Select
0x718	GPIO_TIMER4_CDTI2ROUTE	RW	CDTI2 Port/Pin Select
0x720	GPIO_USART0_ROUTEEN	RW	USART0 Pin Enable
0x724	GPIO_USART0_CSROUTE	RW	CS Port/Pin Select
0x728	GPIO_USART0_CTSROUTE	RW	CTS Port/Pin Select
0x72C	GPIO_USART0_RTSMROUTE	RW	RTS Port/Pin Select
0x730	GPIO_USART0_RXROUTE	RW	RX Port/Pin Select
0x734	GPIO_USART0_CLKROUTE	RW	SCLK Port/Pin Select
0x738	GPIO_USART0_TXROUTE	RW	TX Port/Pin Select
0x1000	GPIO_IPVERSION_SET	R	Main
0x1030	GPIO_PORTA_CTRL_SET	RW	Port Control
0x1034	GPIO_PORTA_MODEL_SET	RW	Mode Low
0x103C	GPIO_PORTA_MODEH_SET	RW	Mode High
0x1040	GPIO_PORTA_DOUT_SET	RW	Data Out
0x1044	GPIO_PORTA_DIN_SET	RH	Data in
0x1060	GPIO_PORTB_CTRL_SET	RW	Port Control
0x1064	GPIO_PORTB_MODEL_SET	RW	Mode Low
0x1070	GPIO_PORTB_DOUT_SET	RW	Data Out
0x1074	GPIO_PORTB_DIN_SET	RH	Data in
0x1090	GPIO_PORTC_CTRL_SET	RW	Port Control
0x1094	GPIO_PORTC_MODEL_SET	RW	Mode Low
0x109C	GPIO_PORTC_MODEH_SET	RW	Mode High
0x10A0	GPIO_PORTC_DOUT_SET	RW	Data Out
0x10A4	GPIO_PORTC_DIN_SET	RH	Data in
0x10C0	GPIO_PORTD_CTRL_SET	RW	Port Control
0x10C4	GPIO_PORTD_MODEL_SET	RW	Mode Low
0x10D0	GPIO_PORTD_DOUT_SET	RW	Data Out
0x10D4	GPIO_PORTD_DIN_SET	RH	Data in
0x1300	GPIO_LOCK_SET	W	Lock Register
0x1310	GPIO_GPIOLOCKSTATUS_SET	RH	Lock Status
0x1320	GPIO_ABUSALLOC_SET	RW	A Bus Allocation
0x1324	GPIO_BBUSALLOC_SET	RW	B Bus Allocation
0x1328	GPIO_CDBUSALLOC_SET	RW	CD Bus Allocation
0x1400	GPIO_EXTIPSELL_SET	RW	External Interrupt Port Select Low

Offset	Name	Type	Description
0x1404	GPIO_EXTIPSELH_SET	RW	External Interrupt Port Select High
0x1408	GPIO_EXTIPINSELL_SET	RW	External Interrupt Pin Select Low
0x140C	GPIO_EXTIPINSELH_SET	RW	External Interrupt Pin Select High
0x1410	GPIO_EXTIRISE_SET	RW	External Interrupt Rising Edge Trigger
0x1414	GPIO_EXTIFALL_SET	RW	External Interrupt Falling Edge Trigger
0x1420	GPIO_IF_SET	RWH INTFLAG	Interrupt Flag
0x1424	GPIO_IEN_SET	RW	Interrupt Enable
0x142C	GPIO_EM4WUEN_SET	RW	EM4 Wakeup Enable
0x1430	GPIO_EM4WUPOL_SET	RW	EM4 Wakeup Polarity
0x1440	GPIO_DBGROUTEPEPEN_SET	RW	Debugger Route Pin Enable
0x1444	GPIO_TRACERROUTEPEPEN_SET	RW	Trace Route Pin Enable
0x1450	GPIO_ACMP0_ROUTEEN_SET	RW	ACMP0 Pin Enable
0x1454	GPIO_ACMP0_ACMPOUT-ROUTE_SET	RW	ACMPOUT Port/Pin Select
0x145C	GPIO_ACMP1_ROUTEEN_SET	RW	ACMP1 Pin Enable
0x1460	GPIO_ACMP1_ACMPOUT-ROUTE_SET	RW	ACMPOUT Port/Pin Select
0x1468	GPIO_CMU_ROUTEEN_SET	RW	CMU Pin Enable
0x146C	GPIO_CMU_CLKIN0ROUTE_SET	RW	CLKIN0 Port/Pin Select
0x1470	GPIO_CMU_CLKOUT0ROUTE_SET	RW	CLKOUT0 Port/Pin Select
0x1474	GPIO_CMU_CLKOUT1ROUTE_SET	RW	CLKOUT1 Port/Pin Select
0x1478	GPIO_CMU_CLKOUT2ROUTE_SET	RW	CLKOUT2 Port/Pin Select
0x1494	GPIO_EUSART0_ROUTEEN_SET	RW	EUSART0 Pin Enable
0x1498	GPIO_EUSART0_CSROUTE_SET	RW	CS Port/Pin Select
0x149C	GPIO_EUSART0_CTSROUTE_SET	RW	CTS Port/Pin Select
0x14A0	GPIO_EUSART0_RTROUTE_SET	RW	RTS Port/Pin Select
0x14A4	GPIO_EUSART0_RXROUTE_SET	RW	RX Port/Pin Select
0x14A8	GPIO_EUSART0_SCLKROUTE_SET	RW	SCLK Port/Pin Select
0x14AC	GPIO_EUSART0_TXROUTE_SET	RW	TX Port/Pin Select
0x14B4	GPIO_EUSART1_ROUTEEN_SET	RW	EUSART1 Pin Enable

Offset	Name	Type	Description
0x14B8	GPIO_EU-SART1_CSROUTE_SET	RW	CS Port/Pin Select
0x14BC	GPIO_EU-SART1_CTSROUTE_SET	RW	CTS Port/Pin Select
0x14C0	GPIO_EU-SART1_RTROUTE_SET	RW	RTS Port/Pin Select
0x14C4	GPIO_EU-SART1_RXROUTE_SET	RW	RX Port/Pin Select
0x14C8	GPIO_EU-SART1_SCLKROUTE_SET	RW	SCLK Port/Pin Select
0x14CC	GPIO_EU-SART1_TXROUTE_SET	RW	TX Port/Pin Select
0x14D4	GPIO_FRC_ROUTEEN_SET	RW	FRC Pin Enable
0x14D8	GPIO_FRC_DCLKROUTE_SET	RW	DCLK Port/Pin Select
0x14DC	GPIO_FRC_DFRAME-ROUTE_SET	RW	DFRAME Port/Pin Select
0x14E0	GPIO_FRC_DOUTROUTE_SET	RW	DOUT Port/Pin Select
0x14E8	GPIO_I2C0_ROUTEEN_SET	RW	I2C0 Pin Enable
0x14EC	GPIO_I2C0_SCLROUTE_SET	RW	SCL Port/Pin Select
0x14F0	GPIO_I2C0_SDARROUTE_SET	RW	SDA Port/Pin Select
0x14F8	GPIO_I2C1_ROUTEEN_SET	RW	I2C1 Pin Enable
0x14FC	GPIO_I2C1_SCLROUTE_SET	RW	SCL Port/Pin Select
0x1500	GPIO_I2C1_SDARROUTE_SET	RW	SDA Port/Pin Select
0x1508	GPIO_KEYSCAN_ROU-TEEN_SET	RW	KEYSCAN Pin Enable
0x150C	GPIO_KEYSCAN_COL-OUT0ROUTE_SET	RW	COLOUT0 Port/Pin Select
0x1510	GPIO_KEYSCAN_COL-OUT1ROUTE_SET	RW	COLOUT1 Port/Pin Select
0x1514	GPIO_KEYSCAN_COL-OUT2ROUTE_SET	RW	COLOUT2 Port/Pin Select
0x1518	GPIO_KEYSCAN_COL-OUT3ROUTE_SET	RW	COLOUT3 Port/Pin Select
0x151C	GPIO_KEYSCAN_COL-OUT4ROUTE_SET	RW	COLOUT4 Port/Pin Select
0x1520	GPIO_KEYSCAN_COL-OUT5ROUTE_SET	RW	COLOUT5 Port/Pin Select
0x1524	GPIO_KEYSCAN_COL-OUT6ROUTE_SET	RW	COLOUT6 Port/Pin Select
0x1528	GPIO_KEYSCAN_COL-OUT7ROUTE_SET	RW	COLOUT7 Port/Pin Select
0x152C	GPIO_KEYSCAN_ROW-SENSE0ROUTE_SET	RW	ROWSENSE0 Port/Pin Select

Offset	Name	Type	Description
0x1530	GPIO_KEYSCAN_ROW-SENSE1ROUTE_SET	RW	ROWSENSE1 Port/Pin Select
0x1534	GPIO_KEYSCAN_ROW-SENSE2ROUTE_SET	RW	ROWSENSE2 Port/Pin Select
0x1538	GPIO_KEYSCAN_ROW-SENSE3ROUTE_SET	RW	ROWSENSE3 Port/Pin Select
0x153C	GPIO_KEYSCAN_ROW-SENSE4ROUTE_SET	RW	ROWSENSE4 Port/Pin Select
0x1540	GPIO_KEYSCAN_ROW-SENSE5ROUTE_SET	RW	ROWSENSE5 Port/Pin Select
0x1548	GPIO_LETIMER_ROU-TEEN_SET	RW	LETIMER Pin Enable
0x154C	GPIO_LETIM-ER_OUT0ROUTE_SET	RW	OUT0 Port/Pin Select
0x1550	GPIO_LETIM-ER_OUT1ROUTE_SET	RW	OUT1 Port/Pin Select
0x1558	GPIO_MODEM_ROUTEEN_SET	RW	MODEM Pin Enable
0x155C	GPIO_MO-DEM_ANT0ROUTE_SET	RW	ANT0 Port/Pin Select
0x1560	GPIO_MO-DEM_ANT1ROUTE_SET	RW	ANT1 Port/Pin Select
0x1564	GPIO_MODEM_ANTROLLO-VERROUTE_SET	RW	ANTROLLOVER Port/Pin Select
0x1568	GPIO_MO-DEM_ANTRR0ROUTE_SET	RW	ANTRR0 Port/Pin Select
0x156C	GPIO_MO-DEM_ANTRR1ROUTE_SET	RW	ANTRR1 Port/Pin Select
0x1570	GPIO_MO-DEM_ANTRR2ROUTE_SET	RW	ANTRR2 Port/Pin Select
0x1574	GPIO_MO-DEM_ANTRR3ROUTE_SET	RW	ANTRR3 Port/Pin Select
0x1578	GPIO_MO-DEM_ANTRR4ROUTE_SET	RW	ANTRR4 Port/Pin Select
0x157C	GPIO_MO-DEM_ANTRR5ROUTE_SET	RW	ANTRR5 Port/Pin Select
0x1580	GPIO_MODEM_ANTSWEN-ROUTE_SET	RW	ANTSWEN Port/Pin Select
0x1584	GPIO_MODEM_ANTSWUS-ROUTE_SET	RW	ANTSWUS Port/Pin Select
0x1588	GPIO_MODEM_ANTTRIG-ROUTE_SET	RW	ANTTRIG Port/Pin Select
0x158C	GPIO_MODEM_ANTTRIGSTOP-ROUTE_SET	RW	ANTTRIGSTOP Port/Pin Select
0x1590	GPIO_MO-DEM_DCLKROUTE_SET	RW	DCLK Port/Pin Select
0x1594	GPIO_MODEM_DIN-ROUTE_SET	RW	DIN Port/Pin Select

Offset	Name	Type	Description
0x1598	GPIO_MODEM_DOUT-ROUTE_SET	RW	DOUT Port/Pin Select
0x15A4	GPIO_PCNT0_S0IN-ROUTE_SET	RW	S0IN Port/Pin Select
0x15A8	GPIO_PCNT0_S1IN-ROUTE_SET	RW	S1IN Port/Pin Select
0x15B0	GPIO_PRS0_ROUTEEN_SET	RW	PRS0 Pin Enable
0x15B4	GPIO_PRS0_ASYNC0ROUTE_SET	RW	ASYNCH0 Port/Pin Select
0x15B8	GPIO_PRS0_ASYNC1ROUTE_SET	RW	ASYNCH1 Port/Pin Select
0x15BC	GPIO_PRS0_ASYNC2ROUTE_SET	RW	ASYNCH2 Port/Pin Select
0x15C0	GPIO_PRS0_ASYNC3ROUTE_SET	RW	ASYNCH3 Port/Pin Select
0x15C4	GPIO_PRS0_ASYNC4ROUTE_SET	RW	ASYNCH4 Port/Pin Select
0x15C8	GPIO_PRS0_ASYNC5ROUTE_SET	RW	ASYNCH5 Port/Pin Select
0x15CC	GPIO_PRS0_ASYNC6ROUTE_SET	RW	ASYNCH6 Port/Pin Select
0x15D0	GPIO_PRS0_ASYNC7ROUTE_SET	RW	ASYNCH7 Port/Pin Select
0x15D4	GPIO_PRS0_ASYNC8ROUTE_SET	RW	ASYNCH8 Port/Pin Select
0x15D8	GPIO_PRS0_ASYNC9ROUTE_SET	RW	ASYNCH9 Port/Pin Select
0x15DC	GPIO_PRS0_ASYNC10ROUTE_SET	RW	ASYNCH10 Port/Pin Select
0x15E0	GPIO_PRS0_ASYNC11ROUTE_SET	RW	ASYNCH11 Port/Pin Select
0x15E4	GPIO_PRS0_ASYNC12ROUTE_SET	RW	ASYNCH12 Port/Pin Select
0x15E8	GPIO_PRS0_ASYNC13ROUTE_SET	RW	ASYNCH13 Port/Pin Select
0x15EC	GPIO_PRS0_ASYNC14ROUTE_SET	RW	ASYNCH14 Port/Pin Select
0x15F0	GPIO_PRS0_ASYNC15ROUTE_SET	RW	ASYNCH15 Port/Pin Select
0x15F4	GPIO_PRS0_SYNC0ROUTE_SET	RW	SYNCH0 Port/Pin Select
0x15F8	GPIO_PRS0_SYNC1ROUTE_SET	RW	SYNCH1 Port/Pin Select
0x15FC	GPIO_PRS0_SYNC2ROUTE_SET	RW	SYNCH2 Port/Pin Select
0x1600	GPIO_PRS0_SYNC3ROUTE_SET	RW	SYNCH3 Port/Pin Select

Offset	Name	Type	Description
0x1608	GPIO_RAC_ROUTEEN_SET	RW	RAC Pin Enable
0x160C	GPIO_RAC_LNAEN-ROUTE_SET	RW	LNAEN Port/Pin Select
0x1610	GPIO_RAC_PAENROUTE_SET	RW	PAEN Port/Pin Select
0x1678	GPIO_SYX00_BUFOUTREQI-NASYNCROUTE_SET	RW	BUFOUTREQINASYNC Port/Pin Select
0x1680	GPIO_TIMER0_ROUTEEN_SET	RW	TIMER0 Pin Enable
0x1684	GPIO_TIMER0_CC0ROUTE_SET	RW	CC0 Port/Pin Select
0x1688	GPIO_TIMER0_CC1ROUTE_SET	RW	CC1 Port/Pin Select
0x168C	GPIO_TIMER0_CC2ROUTE_SET	RW	CC2 Port/Pin Select
0x1690	GPIO_TIMER0_CDTI0ROUTE_SET	RW	CDTI0 Port/Pin Select
0x1694	GPIO_TIMER0_CDTI1ROUTE_SET	RW	CDTI1 Port/Pin Select
0x1698	GPIO_TIMER0_CDTI2ROUTE_SET	RW	CDTI2 Port/Pin Select
0x16A0	GPIO_TIMER1_ROUTEEN_SET	RW	TIMER1 Pin Enable
0x16A4	GPIO_TIMER1_CC0ROUTE_SET	RW	CC0 Port/Pin Select
0x16A8	GPIO_TIMER1_CC1ROUTE_SET	RW	CC1 Port/Pin Select
0x16AC	GPIO_TIMER1_CC2ROUTE_SET	RW	CC2 Port/Pin Select
0x16B0	GPIO_TIMER1_CDTI0ROUTE_SET	RW	CDTI0 Port/Pin Select
0x16B4	GPIO_TIMER1_CDTI1ROUTE_SET	RW	CDTI1 Port/Pin Select
0x16B8	GPIO_TIMER1_CDTI2ROUTE_SET	RW	CDTI2 Port/Pin Select
0x16C0	GPIO_TIMER2_ROUTEEN_SET	RW	TIMER2 Pin Enable
0x16C4	GPIO_TIMER2_CC0ROUTE_SET	RW	CC0 Port/Pin Select
0x16C8	GPIO_TIMER2_CC1ROUTE_SET	RW	CC1 Port/Pin Select
0x16CC	GPIO_TIMER2_CC2ROUTE_SET	RW	CC2 Port/Pin Select
0x16D0	GPIO_TIMER2_CDTI0ROUTE_SET	RW	CDTI0 Port/Pin Select
0x16D4	GPIO_TIMER2_CDTI1ROUTE_SET	RW	CDTI1 Port/Pin Select
0x16D8	GPIO_TIMER2_CDTI2ROUTE_SET	RW	CDTI2 Port/Pin Select

Offset	Name	Type	Description
0x16E0	GPIO_TIMER3_ROUTEEN_SET	RW	TIMER3 Pin Enable
0x16E4	GPIO_TIMER3_CC0ROUTE_SET	RW	CC0 Port/Pin Select
0x16E8	GPIO_TIMER3_CC1ROUTE_SET	RW	CC1 Port/Pin Select
0x16EC	GPIO_TIMER3_CC2ROUTE_SET	RW	CC2 Port/Pin Select
0x16F0	GPIO_TIMER3_CDTI0ROUTE_SET	RW	CDTI0 Port/Pin Select
0x16F4	GPIO_TIMER3_CDTI1ROUTE_SET	RW	CDTI1 Port/Pin Select
0x16F8	GPIO_TIMER3_CDTI2ROUTE_SET	RW	CDTI2 Port/Pin Select
0x1700	GPIO_TIMER4_ROUTEEN_SET	RW	TIMER4 Pin Enable
0x1704	GPIO_TIMER4_CC0ROUTE_SET	RW	CC0 Port/Pin Select
0x1708	GPIO_TIMER4_CC1ROUTE_SET	RW	CC1 Port/Pin Select
0x170C	GPIO_TIMER4_CC2ROUTE_SET	RW	CC2 Port/Pin Select
0x1710	GPIO_TIMER4_CDTI0ROUTE_SET	RW	CDTI0 Port/Pin Select
0x1714	GPIO_TIMER4_CDTI1ROUTE_SET	RW	CDTI1 Port/Pin Select
0x1718	GPIO_TIMER4_CDTI2ROUTE_SET	RW	CDTI2 Port/Pin Select
0x1720	GPIO_USART0_ROUTEEN_SET	RW	USART0 Pin Enable
0x1724	GPIO_USART0_CSROUTE_SET	RW	CS Port/Pin Select
0x1728	GPIO_USART0_CTSROUTE_SET	RW	CTS Port/Pin Select
0x172C	GPIO_USART0_RTROUTE_SET	RW	RTS Port/Pin Select
0x1730	GPIO_USART0_RXROUTE_SET	RW	RX Port/Pin Select
0x1734	GPIO_USART0_CLKROUTE_SET	RW	SCLK Port/Pin Select
0x1738	GPIO_USART0_TXROUTE_SET	RW	TX Port/Pin Select
0x2000	GPIO_IPVERSION_CLR	R	Main
0x2030	GPIO_PORTA_CTRL_CLR	RW	Port Control
0x2034	GPIO_PORTA_MODEL_CLR	RW	Mode Low
0x203C	GPIO_PORTA_MODEH_CLR	RW	Mode High
0x2040	GPIO_PORTA_DOUT_CLR	RW	Data Out

Offset	Name	Type	Description
0x2044	GPIO_PORTA_DIN_CLR	RH	Data in
0x2060	GPIO_PORTB_CTRL_CLR	RW	Port Control
0x2064	GPIO_PORTB_MODEL_CLR	RW	Mode Low
0x2070	GPIO_PORTB_DOUT_CLR	RW	Data Out
0x2074	GPIO_PORTB_DIN_CLR	RH	Data in
0x2090	GPIO_PORTC_CTRL_CLR	RW	Port Control
0x2094	GPIO_PORTC_MODEL_CLR	RW	Mode Low
0x209C	GPIO_PORTC_MODEH_CLR	RW	Mode High
0x20A0	GPIO_PORTC_DOUT_CLR	RW	Data Out
0x20A4	GPIO_PORTC_DIN_CLR	RH	Data in
0x20C0	GPIO_PORTD_CTRL_CLR	RW	Port Control
0x20C4	GPIO_PORTD_MODEL_CLR	RW	Mode Low
0x20D0	GPIO_PORTD_DOUT_CLR	RW	Data Out
0x20D4	GPIO_PORTD_DIN_CLR	RH	Data in
0x2300	GPIO_LOCK_CLR	W	Lock Register
0x2310	GPIO_GPILOCKSTATUS_CLR	RH	Lock Status
0x2320	GPIO_ABUSALLOC_CLR	RW	A Bus Allocation
0x2324	GPIO_BBUSALLOC_CLR	RW	B Bus Allocation
0x2328	GPIO_CDBUSALLOC_CLR	RW	CD Bus Allocation
0x2400	GPIO_EXTIPSELL_CLR	RW	External Interrupt Port Select Low
0x2404	GPIO_EXTIPSELH_CLR	RW	External Interrupt Port Select High
0x2408	GPIO_EXTIPINSELL_CLR	RW	External Interrupt Pin Select Low
0x240C	GPIO_EXTIPINSELH_CLR	RW	External Interrupt Pin Select High
0x2410	GPIO_EXTIRISE_CLR	RW	External Interrupt Rising Edge Trigger
0x2414	GPIO_EXTIFALL_CLR	RW	External Interrupt Falling Edge Trigger
0x2420	GPIO_IF_CLR	RWH INTFLAG	Interrupt Flag
0x2424	GPIO_IEN_CLR	RW	Interrupt Enable
0x242C	GPIO_EM4WUEN_CLR	RW	EM4 Wakeup Enable
0x2430	GPIO_EM4WUPOL_CLR	RW	EM4 Wakeup Polarity
0x2440	GPIO_DBGROUTEPEEN_CLR	RW	Debugger Route Pin Enable
0x2444	GPIO_TRACROUTEPEEN_CLR	RW	Trace Route Pin Enable
0x2450	GPIO_ACOMP0_ROUTEEN_CLR	RW	ACMP0 Pin Enable
0x2454	GPIO_ACOMP0_ACMPOUT-ROUTE_CLR	RW	ACMPOUT Port/Pin Select
0x245C	GPIO_ACOMP1_ROUTEEN_CLR	RW	ACMP1 Pin Enable
0x2460	GPIO_ACOMP1_ACMPOUT-ROUTE_CLR	RW	ACMPOUT Port/Pin Select
0x2468	GPIO_CMU_ROUTEEN_CLR	RW	CMU Pin Enable

Offset	Name	Type	Description
0x246C	GPIO_CMU_CLKIN0ROUTE_CLR	RW	CLKIN0 Port/Pin Select
0x2470	GPIO_CMU_CLKOUT0ROUTE_CLR	RW	CLKOUT0 Port/Pin Select
0x2474	GPIO_CMU_CLKOUT1ROUTE_CLR	RW	CLKOUT1 Port/Pin Select
0x2478	GPIO_CMU_CLKOUT2ROUTE_CLR	RW	CLKOUT2 Port/Pin Select
0x2494	GPIO_EUSART0_ROUTEEN_CLR	RW	EUSART0 Pin Enable
0x2498	GPIO_EUSART0_CSROUTE_CLR	RW	CS Port/Pin Select
0x249C	GPIO_EUSART0_CTSROUTE_CLR	RW	CTS Port/Pin Select
0x24A0	GPIO_EUSART0_RTSMROUTE_CLR	RW	RTS Port/Pin Select
0x24A4	GPIO_EUSART0_RXROUTE_CLR	RW	RX Port/Pin Select
0x24A8	GPIO_EUSART0_SCLKROUTE_CLR	RW	SCLK Port/Pin Select
0x24AC	GPIO_EUSART0_TXROUTE_CLR	RW	TX Port/Pin Select
0x24B4	GPIO_EUSART1_ROUTEEN_CLR	RW	EUSART1 Pin Enable
0x24B8	GPIO_EUSART1_CSROUTE_CLR	RW	CS Port/Pin Select
0x24BC	GPIO_EUSART1_CTSROUTE_CLR	RW	CTS Port/Pin Select
0x24C0	GPIO_EUSART1_RTSMROUTE_CLR	RW	RTS Port/Pin Select
0x24C4	GPIO_EUSART1_RXROUTE_CLR	RW	RX Port/Pin Select
0x24C8	GPIO_EUSART1_SCLKROUTE_CLR	RW	SCLK Port/Pin Select
0x24CC	GPIO_EUSART1_TXROUTE_CLR	RW	TX Port/Pin Select
0x24D4	GPIO_FRC_ROUTEEN_CLR	RW	FRC Pin Enable
0x24D8	GPIO_FRC_DCLKROUTE_CLR	RW	DCLK Port/Pin Select
0x24DC	GPIO_FRC_DFRAMEROUTE_CLR	RW	DFRAME Port/Pin Select
0x24E0	GPIO_FRC_DOUTROUTE_CLR	RW	DOUT Port/Pin Select
0x24E8	GPIO_I2C0_ROUTEEN_CLR	RW	I2C0 Pin Enable
0x24EC	GPIO_I2C0_SCLROUTE_CLR	RW	SCL Port/Pin Select
0x24F0	GPIO_I2C0_SDARROUTE_CLR	RW	SDA Port/Pin Select
0x24F8	GPIO_I2C1_ROUTEEN_CLR	RW	I2C1 Pin Enable

Offset	Name	Type	Description
0x24FC	GPIO_I2C1_SCLROUTE_CLR	RW	SCL Port/Pin Select
0x2500	GPIO_I2C1_SDARROUTE_CLR	RW	SDA Port/Pin Select
0x2508	GPIO_KEYSCAN_ROU- TEEN_CLR	RW	KEYSCAN Pin Enable
0x250C	GPIO_KEYSCAN_COL- OUT0ROUTE_CLR	RW	COLOUT0 Port/Pin Select
0x2510	GPIO_KEYSCAN_COL- OUT1ROUTE_CLR	RW	COLOUT1 Port/Pin Select
0x2514	GPIO_KEYSCAN_COL- OUT2ROUTE_CLR	RW	COLOUT2 Port/Pin Select
0x2518	GPIO_KEYSCAN_COL- OUT3ROUTE_CLR	RW	COLOUT3 Port/Pin Select
0x251C	GPIO_KEYSCAN_COL- OUT4ROUTE_CLR	RW	COLOUT4 Port/Pin Select
0x2520	GPIO_KEYSCAN_COL- OUT5ROUTE_CLR	RW	COLOUT5 Port/Pin Select
0x2524	GPIO_KEYSCAN_COL- OUT6ROUTE_CLR	RW	COLOUT6 Port/Pin Select
0x2528	GPIO_KEYSCAN_COL- OUT7ROUTE_CLR	RW	COLOUT7 Port/Pin Select
0x252C	GPIO_KEYSCAN_ROW- SENSE0ROUTE_CLR	RW	ROWSENSE0 Port/Pin Select
0x2530	GPIO_KEYSCAN_ROW- SENSE1ROUTE_CLR	RW	ROWSENSE1 Port/Pin Select
0x2534	GPIO_KEYSCAN_ROW- SENSE2ROUTE_CLR	RW	ROWSENSE2 Port/Pin Select
0x2538	GPIO_KEYSCAN_ROW- SENSE3ROUTE_CLR	RW	ROWSENSE3 Port/Pin Select
0x253C	GPIO_KEYSCAN_ROW- SENSE4ROUTE_CLR	RW	ROWSENSE4 Port/Pin Select
0x2540	GPIO_KEYSCAN_ROW- SENSE5ROUTE_CLR	RW	ROWSENSE5 Port/Pin Select
0x2548	GPIO_LETIMER_ROU- TEEN_CLR	RW	LETIMER Pin Enable
0x254C	GPIO_LETIM- ER_OUT0ROUTE_CLR	RW	OUT0 Port/Pin Select
0x2550	GPIO_LETIM- ER_OUT1ROUTE_CLR	RW	OUT1 Port/Pin Select
0x2558	GPIO_MODEM_ROUTEEN_CLR	RW	MODEM Pin Enable
0x255C	GPIO_MO- DEM_ANT0ROUTE_CLR	RW	ANT0 Port/Pin Select
0x2560	GPIO_MO- DEM_ANT1ROUTE_CLR	RW	ANT1 Port/Pin Select
0x2564	GPIO_MODEM_ANTROLLO- VERROUTE_CLR	RW	ANTROLLOVER Port/Pin Select

Offset	Name	Type	Description
0x2568	GPIO_MO- DEM_ANTRR0ROUTE_CLR	RW	ANTRR0 Port/Pin Select
0x256C	GPIO_MO- DEM_ANTRR1ROUTE_CLR	RW	ANTRR1 Port/Pin Select
0x2570	GPIO_MO- DEM_ANTRR2ROUTE_CLR	RW	ANTRR2 Port/Pin Select
0x2574	GPIO_MO- DEM_ANTRR3ROUTE_CLR	RW	ANTRR3 Port/Pin Select
0x2578	GPIO_MO- DEM_ANTRR4ROUTE_CLR	RW	ANTRR4 Port/Pin Select
0x257C	GPIO_MO- DEM_ANTRR5ROUTE_CLR	RW	ANTRR5 Port/Pin Select
0x2580	GPIO_MODEM_ANTSWEN- ROUTE_CLR	RW	ANTSWEN Port/Pin Select
0x2584	GPIO_MODEM_ANTSWUS- ROUTE_CLR	RW	ANTSWUS Port/Pin Select
0x2588	GPIO_MODEM_ANTTRIG- ROUTE_CLR	RW	ANTTRIG Port/Pin Select
0x258C	GPIO_MODEM_ANTTRIGSTOP- ROUTE_CLR	RW	ANTTRIGSTOP Port/Pin Select
0x2590	GPIO_MO- DEM_DCLKROUTE_CLR	RW	DCLK Port/Pin Select
0x2594	GPIO_MODEM_DIN- ROUTE_CLR	RW	DIN Port/Pin Select
0x2598	GPIO_MODEM_DOUT- ROUTE_CLR	RW	DOUT Port/Pin Select
0x25A4	GPIO_PCNT0_S0IN- ROUTE_CLR	RW	S0IN Port/Pin Select
0x25A8	GPIO_PCNT0_S1IN- ROUTE_CLR	RW	S1IN Port/Pin Select
0x25B0	GPIO_PRS0_ROUTEEN_CLR	RW	PRS0 Pin Enable
0x25B4	GPIO_PRS0_ASYNCH0ROUTE _CLR	RW	ASYNCH0 Port/Pin Select
0x25B8	GPIO_PRS0_ASYNCH1ROUTE _CLR	RW	ASYNCH1 Port/Pin Select
0x25BC	GPIO_PRS0_ASYNCH2ROUTE _CLR	RW	ASYNCH2 Port/Pin Select
0x25C0	GPIO_PRS0_ASYNCH3ROUTE _CLR	RW	ASYNCH3 Port/Pin Select
0x25C4	GPIO_PRS0_ASYNCH4ROUTE _CLR	RW	ASYNCH4 Port/Pin Select
0x25C8	GPIO_PRS0_ASYNCH5ROUTE _CLR	RW	ASYNCH5 Port/Pin Select
0x25CC	GPIO_PRS0_ASYNCH6ROUTE _CLR	RW	ASYNCH6 Port/Pin Select
0x25D0	GPIO_PRS0_ASYNCH7ROUTE _CLR	RW	ASYNCH7 Port/Pin Select

Offset	Name	Type	Description
0x25D4	GPIO_PRS0_ASYNCH8ROUTE_CLR	RW	ASYNCH8 Port/Pin Select
0x25D8	GPIO_PRS0_ASYNCH9ROUTE_CLR	RW	ASYNCH9 Port/Pin Select
0x25DC	GPIO_PRS0_ASYNCH10ROUTE_CLR	RW	ASYNCH10 Port/Pin Select
0x25E0	GPIO_PRS0_ASYNCH11ROUTE_CLR	RW	ASYNCH11 Port/Pin Select
0x25E4	GPIO_PRS0_ASYNCH12ROUTE_CLR	RW	ASYNCH12 Port/Pin Select
0x25E8	GPIO_PRS0_ASYNCH13ROUTE_CLR	RW	ASYNCH13 Port/Pin Select
0x25EC	GPIO_PRS0_ASYNCH14ROUTE_CLR	RW	ASYNCH14 Port/Pin Select
0x25F0	GPIO_PRS0_ASYNCH15ROUTE_CLR	RW	ASYNCH15 Port/Pin Select
0x25F4	GPIO_PRS0_SYNCH0ROUTE_CLR	RW	SYNCH0 Port/Pin Select
0x25F8	GPIO_PRS0_SYNCH1ROUTE_CLR	RW	SYNCH1 Port/Pin Select
0x25FC	GPIO_PRS0_SYNCH2ROUTE_CLR	RW	SYNCH2 Port/Pin Select
0x2600	GPIO_PRS0_SYNCH3ROUTE_CLR	RW	SYNCH3 Port/Pin Select
0x2608	GPIO_RAC_ROUTEEN_CLR	RW	RAC Pin Enable
0x260C	GPIO_RAC_LNAEN_ROUTE_CLR	RW	LNAEN Port/Pin Select
0x2610	GPIO_RAC_PAENROUTE_CLR	RW	PAEN Port/Pin Select
0x2678	GPIO_SYXO0_BUFOUTREQUIRENASYNCROUTE_CLR	RW	BUFOUTREQUIRENASYNC Port/Pin Select
0x2680	GPIO_TIMER0_ROUTEEN_CLR	RW	TIMER0 Pin Enable
0x2684	GPIO_TIMER0_CC0ROUTE_CLR	RW	CC0 Port/Pin Select
0x2688	GPIO_TIMER0_CC1ROUTE_CLR	RW	CC1 Port/Pin Select
0x268C	GPIO_TIMER0_CC2ROUTE_CLR	RW	CC2 Port/Pin Select
0x2690	GPIO_TIMER0_CDTI0ROUTE_CLR	RW	CDTI0 Port/Pin Select
0x2694	GPIO_TIMER0_CDTI1ROUTE_CLR	RW	CDTI1 Port/Pin Select
0x2698	GPIO_TIMER0_CDTI2ROUTE_CLR	RW	CDTI2 Port/Pin Select
0x26A0	GPIO_TIMER1_ROUTEEN_CLR	RW	TIMER1 Pin Enable
0x26A4	GPIO_TIMER1_CC0ROUTE_CLR	RW	CC0 Port/Pin Select

Offset	Name	Type	Description
0x26A8	GPIO_TIMER1_CC1ROUTE_CLR	RW	CC1 Port/Pin Select
0x26AC	GPIO_TIMER1_CC2ROUTE_CLR	RW	CC2 Port/Pin Select
0x26B0	GPIO_TIMER1_CDTI0ROUTE_CLR	RW	CDTI0 Port/Pin Select
0x26B4	GPIO_TIMER1_CDTI1ROUTE_CLR	RW	CDTI1 Port/Pin Select
0x26B8	GPIO_TIMER1_CDTI2ROUTE_CLR	RW	CDTI2 Port/Pin Select
0x26C0	GPIO_TIMER2_ROUTEEN_CLR	RW	TIMER2 Pin Enable
0x26C4	GPIO_TIMER2_CC0ROUTE_CLR	RW	CC0 Port/Pin Select
0x26C8	GPIO_TIMER2_CC1ROUTE_CLR	RW	CC1 Port/Pin Select
0x26CC	GPIO_TIMER2_CC2ROUTE_CLR	RW	CC2 Port/Pin Select
0x26D0	GPIO_TIMER2_CDTI0ROUTE_CLR	RW	CDTI0 Port/Pin Select
0x26D4	GPIO_TIMER2_CDTI1ROUTE_CLR	RW	CDTI1 Port/Pin Select
0x26D8	GPIO_TIMER2_CDTI2ROUTE_CLR	RW	CDTI2 Port/Pin Select
0x26E0	GPIO_TIMER3_ROUTEEN_CLR	RW	TIMER3 Pin Enable
0x26E4	GPIO_TIMER3_CC0ROUTE_CLR	RW	CC0 Port/Pin Select
0x26E8	GPIO_TIMER3_CC1ROUTE_CLR	RW	CC1 Port/Pin Select
0x26EC	GPIO_TIMER3_CC2ROUTE_CLR	RW	CC2 Port/Pin Select
0x26F0	GPIO_TIMER3_CDTI0ROUTE_CLR	RW	CDTI0 Port/Pin Select
0x26F4	GPIO_TIMER3_CDTI1ROUTE_CLR	RW	CDTI1 Port/Pin Select
0x26F8	GPIO_TIMER3_CDTI2ROUTE_CLR	RW	CDTI2 Port/Pin Select
0x2700	GPIO_TIMER4_ROUTEEN_CLR	RW	TIMER4 Pin Enable
0x2704	GPIO_TIMER4_CC0ROUTE_CLR	RW	CC0 Port/Pin Select
0x2708	GPIO_TIMER4_CC1ROUTE_CLR	RW	CC1 Port/Pin Select
0x270C	GPIO_TIMER4_CC2ROUTE_CLR	RW	CC2 Port/Pin Select
0x2710	GPIO_TIMER4_CDTI0ROUTE_CLR	RW	CDTI0 Port/Pin Select

Offset	Name	Type	Description
0x2714	GPIO_TIMER4_CDTI1ROUTE_CLR	RW	CDTI1 Port/Pin Select
0x2718	GPIO_TIMER4_CDTI2ROUTE_CLR	RW	CDTI2 Port/Pin Select
0x2720	GPIO_USART0_ROUTEEN_CLR	RW	USART0 Pin Enable
0x2724	GPIO_USART0_CSROUTE_CLR	RW	CS Port/Pin Select
0x2728	GPIO_USART0_CTSROUTE_CLR	RW	CTS Port/Pin Select
0x272C	GPIO_USART0_RTROUTE_CLR	RW	RTS Port/Pin Select
0x2730	GPIO_USART0_RXROUTE_CLR	RW	RX Port/Pin Select
0x2734	GPIO_USART0_CLKROUTE_CLR	RW	SCLK Port/Pin Select
0x2738	GPIO_USART0_TXROUTE_CLR	RW	TX Port/Pin Select
0x3000	GPIO_IPVERSION_TGL	R	Main
0x3030	GPIO_PORTA_CTRL_TGL	RW	Port Control
0x3034	GPIO_PORTA_MODEL_TGL	RW	Mode Low
0x303C	GPIO_PORTA_MODEH_TGL	RW	Mode High
0x3040	GPIO_PORTA_DOUT_TGL	RW	Data Out
0x3044	GPIO_PORTA_DIN_TGL	RH	Data in
0x3060	GPIO_PORTB_CTRL_TGL	RW	Port Control
0x3064	GPIO_PORTB_MODEL_TGL	RW	Mode Low
0x3070	GPIO_PORTB_DOUT_TGL	RW	Data Out
0x3074	GPIO_PORTB_DIN_TGL	RH	Data in
0x3090	GPIO_PORTC_CTRL_TGL	RW	Port Control
0x3094	GPIO_PORTC_MODEL_TGL	RW	Mode Low
0x309C	GPIO_PORTC_MODEH_TGL	RW	Mode High
0x30A0	GPIO_PORTC_DOUT_TGL	RW	Data Out
0x30A4	GPIO_PORTC_DIN_TGL	RH	Data in
0x30C0	GPIO_PORTD_CTRL_TGL	RW	Port Control
0x30C4	GPIO_PORTD_MODEL_TGL	RW	Mode Low
0x30D0	GPIO_PORTD_DOUT_TGL	RW	Data Out
0x30D4	GPIO_PORTD_DIN_TGL	RH	Data in
0x3300	GPIO_LOCK_TGL	W	Lock Register
0x3310	GPIO_GPIOLOCKSTATUS_TGL	RH	Lock Status
0x3320	GPIO_ABUSALLOC_TGL	RW	A Bus Allocation
0x3324	GPIO_BBUSALLOC_TGL	RW	B Bus Allocation

Offset	Name	Type	Description
0x3328	GPIO_CDBUSALLOC_TGL	RW	CD Bus Allocation
0x3400	GPIO_EXTIPSELL_TGL	RW	External Interrupt Port Select Low
0x3404	GPIO_EXTIPSELH_TGL	RW	External Interrupt Port Select High
0x3408	GPIO_EXTIPINSELL_TGL	RW	External Interrupt Pin Select Low
0x340C	GPIO_EXTIPINSELH_TGL	RW	External Interrupt Pin Select High
0x3410	GPIO_EXTIRISE_TGL	RW	External Interrupt Rising Edge Trigger
0x3414	GPIO_EXTIFALL_TGL	RW	External Interrupt Falling Edge Trigger
0x3420	GPIO_IF_TGL	RWH INTFLAG	Interrupt Flag
0x3424	GPIO_IEN_TGL	RW	Interrupt Enable
0x342C	GPIO_EM4WUEN_TGL	RW	EM4 Wakeup Enable
0x3430	GPIO_EM4WUPOL_TGL	RW	EM4 Wakeup Polarity
0x3440	GPIO_DBGROUTEPEN_TGL	RW	Debugger Route Pin Enable
0x3444	GPIO_TRACROUTEPEN_TGL	RW	Trace Route Pin Enable
0x3450	GPIO_ACMP0_ROUTEEN_TGL	RW	ACMP0 Pin Enable
0x3454	GPIO_ACMP0_ACMPOUT-ROUTE_TGL	RW	ACMPOUT Port/Pin Select
0x345C	GPIO_ACMP1_ROUTEEN_TGL	RW	ACMP1 Pin Enable
0x3460	GPIO_ACMP1_ACMPOUT-ROUTE_TGL	RW	ACMPOUT Port/Pin Select
0x3468	GPIO_CMU_ROUTEEN_TGL	RW	CMU Pin Enable
0x346C	GPIO_CMU_CLKIN0ROUTE_TGL	RW	CLKIN0 Port/Pin Select
0x3470	GPIO_CMU_CLKOUT0ROUTE_TGL	RW	CLKOUT0 Port/Pin Select
0x3474	GPIO_CMU_CLKOUT1ROUTE_TGL	RW	CLKOUT1 Port/Pin Select
0x3478	GPIO_CMU_CLKOUT2ROUTE_TGL	RW	CLKOUT2 Port/Pin Select
0x3494	GPIO_EUSART0_ROUTEEN_TGL	RW	EUSART0 Pin Enable
0x3498	GPIO_EUSART0_CSROUTE_TGL	RW	CS Port/Pin Select
0x349C	GPIO_EUSART0_CTSROUTE_TGL	RW	CTS Port/Pin Select
0x34A0	GPIO_EUSART0_RTROUTE_TGL	RW	RTS Port/Pin Select
0x34A4	GPIO_EUSART0_RXROUTE_TGL	RW	RX Port/Pin Select
0x34A8	GPIO_EUSART0_SCLKROUTE_TGL	RW	SCLK Port/Pin Select
0x34AC	GPIO_EUSART0_TXROUTE_TGL	RW	TX Port/Pin Select

Offset	Name	Type	Description
0x34B4	GPIO_EUSART1_ROUTEEN_TGL	RW	EUSART1 Pin Enable
0x34B8	GPIO_EUSART1_CSROUTE_TGL	RW	CS Port/Pin Select
0x34BC	GPIO_EUSART1_CTSROUTE_TGL	RW	CTS Port/Pin Select
0x34C0	GPIO_EUSART1_RTROUTE_TGL	RW	RTS Port/Pin Select
0x34C4	GPIO_EUSART1_RXROUTE_TGL	RW	RX Port/Pin Select
0x34C8	GPIO_EUSART1_SCLKROUTE_TGL	RW	SCLK Port/Pin Select
0x34CC	GPIO_EUSART1_TXROUTE_TGL	RW	TX Port/Pin Select
0x34D4	GPIO_FRC_ROUTEEN_TGL	RW	FRC Pin Enable
0x34D8	GPIO_FRC_DCLKROUTE_TGL	RW	DCLK Port/Pin Select
0x34DC	GPIO_FRC_DFRAMEROUTE_TGL	RW	DFRAME Port/Pin Select
0x34E0	GPIO_FRC_DOUTROUTE_TGL	RW	DOUT Port/Pin Select
0x34E8	GPIO_I2C0_ROUTEEN_TGL	RW	I2C0 Pin Enable
0x34EC	GPIO_I2C0_SCLROUTE_TGL	RW	SCL Port/Pin Select
0x34F0	GPIO_I2C0_SDARROUTE_TGL	RW	SDA Port/Pin Select
0x34F8	GPIO_I2C1_ROUTEEN_TGL	RW	I2C1 Pin Enable
0x34FC	GPIO_I2C1_SCLROUTE_TGL	RW	SCL Port/Pin Select
0x3500	GPIO_I2C1_SDARROUTE_TGL	RW	SDA Port/Pin Select
0x3508	GPIO_KEYSCAN_ROUTEEN_TGL	RW	KEYSCAN Pin Enable
0x350C	GPIO_KEYSCAN_COLOUT0ROUTE_TGL	RW	COLOUT0 Port/Pin Select
0x3510	GPIO_KEYSCAN_COLOUT1ROUTE_TGL	RW	COLOUT1 Port/Pin Select
0x3514	GPIO_KEYSCAN_COLOUT2ROUTE_TGL	RW	COLOUT2 Port/Pin Select
0x3518	GPIO_KEYSCAN_COLOUT3ROUTE_TGL	RW	COLOUT3 Port/Pin Select
0x351C	GPIO_KEYSCAN_COLOUT4ROUTE_TGL	RW	COLOUT4 Port/Pin Select
0x3520	GPIO_KEYSCAN_COLOUT5ROUTE_TGL	RW	COLOUT5 Port/Pin Select
0x3524	GPIO_KEYSCAN_COLOUT6ROUTE_TGL	RW	COLOUT6 Port/Pin Select
0x3528	GPIO_KEYSCAN_COLOUT7ROUTE_TGL	RW	COLOUT7 Port/Pin Select

Offset	Name	Type	Description
0x352C	GPIO_KEYSCAN_ROW-SENSE0ROUTE_TGL	RW	ROWSENSE0 Port/Pin Select
0x3530	GPIO_KEYSCAN_ROW-SENSE1ROUTE_TGL	RW	ROWSENSE1 Port/Pin Select
0x3534	GPIO_KEYSCAN_ROW-SENSE2ROUTE_TGL	RW	ROWSENSE2 Port/Pin Select
0x3538	GPIO_KEYSCAN_ROW-SENSE3ROUTE_TGL	RW	ROWSENSE3 Port/Pin Select
0x353C	GPIO_KEYSCAN_ROW-SENSE4ROUTE_TGL	RW	ROWSENSE4 Port/Pin Select
0x3540	GPIO_KEYSCAN_ROW-SENSE5ROUTE_TGL	RW	ROWSENSE5 Port/Pin Select
0x3548	GPIO_LETIMER_ROU-TEEN_TGL	RW	LETIMER Pin Enable
0x354C	GPIO_LETIM-ER_OUT0ROUTE_TGL	RW	OUT0 Port/Pin Select
0x3550	GPIO_LETIM-ER_OUT1ROUTE_TGL	RW	OUT1 Port/Pin Select
0x3558	GPIO_MODEM_ROUTEEN_TGL	RW	MODEM Pin Enable
0x355C	GPIO_MO-DEM_ANT0ROUTE_TGL	RW	ANT0 Port/Pin Select
0x3560	GPIO_MO-DEM_ANT1ROUTE_TGL	RW	ANT1 Port/Pin Select
0x3564	GPIO_MODEM_ANTROLLO-VERROUTE_TGL	RW	ANTROLLOVER Port/Pin Select
0x3568	GPIO_MO-DEM_ANTRR0ROUTE_TGL	RW	ANTRR0 Port/Pin Select
0x356C	GPIO_MO-DEM_ANTRR1ROUTE_TGL	RW	ANTRR1 Port/Pin Select
0x3570	GPIO_MO-DEM_ANTRR2ROUTE_TGL	RW	ANTRR2 Port/Pin Select
0x3574	GPIO_MO-DEM_ANTRR3ROUTE_TGL	RW	ANTRR3 Port/Pin Select
0x3578	GPIO_MO-DEM_ANTRR4ROUTE_TGL	RW	ANTRR4 Port/Pin Select
0x357C	GPIO_MO-DEM_ANTRR5ROUTE_TGL	RW	ANTRR5 Port/Pin Select
0x3580	GPIO_MODEM_ANTSWEN-ROUTE_TGL	RW	ANTSWEN Port/Pin Select
0x3584	GPIO_MODEM_ANTSWUS-ROUTE_TGL	RW	ANTSWUS Port/Pin Select
0x3588	GPIO_MODEM_ANTTRIG-ROUTE_TGL	RW	ANTTRIG Port/Pin Select
0x358C	GPIO_MODEM_ANTTRIGSTOP-ROUTE_TGL	RW	ANTTRIGSTOP Port/Pin Select
0x3590	GPIO_MO-DEM_DCLKROUTE_TGL	RW	DCLK Port/Pin Select

Offset	Name	Type	Description
0x3594	GPIO_MODEM_DIN-ROUTE_TGL	RW	DIN Port/Pin Select
0x3598	GPIO_MODEM_DOUT-ROUTE_TGL	RW	DOUT Port/Pin Select
0x35A4	GPIO_PCNT0_S0IN-ROUTE_TGL	RW	S0IN Port/Pin Select
0x35A8	GPIO_PCNT0_S1IN-ROUTE_TGL	RW	S1IN Port/Pin Select
0x35B0	GPIO_PRS0_ROUTEEN_TGL	RW	PRS0 Pin Enable
0x35B4	GPIO_PRS0_ASYNC0ROUTE_TGL	RW	ASYNCH0 Port/Pin Select
0x35B8	GPIO_PRS0_ASYNC1ROUTE_TGL	RW	ASYNCH1 Port/Pin Select
0x35BC	GPIO_PRS0_ASYNC2ROUTE_TGL	RW	ASYNCH2 Port/Pin Select
0x35C0	GPIO_PRS0_ASYNC3ROUTE_TGL	RW	ASYNCH3 Port/Pin Select
0x35C4	GPIO_PRS0_ASYNC4ROUTE_TGL	RW	ASYNCH4 Port/Pin Select
0x35C8	GPIO_PRS0_ASYNC5ROUTE_TGL	RW	ASYNCH5 Port/Pin Select
0x35CC	GPIO_PRS0_ASYNC6ROUTE_TGL	RW	ASYNCH6 Port/Pin Select
0x35D0	GPIO_PRS0_ASYNC7ROUTE_TGL	RW	ASYNCH7 Port/Pin Select
0x35D4	GPIO_PRS0_ASYNC8ROUTE_TGL	RW	ASYNCH8 Port/Pin Select
0x35D8	GPIO_PRS0_ASYNC9ROUTE_TGL	RW	ASYNCH9 Port/Pin Select
0x35DC	GPIO_PRS0_ASYNC10ROUTE_TGL	RW	ASYNCH10 Port/Pin Select
0x35E0	GPIO_PRS0_ASYNC11ROUTE_TGL	RW	ASYNCH11 Port/Pin Select
0x35E4	GPIO_PRS0_ASYNC12ROUTE_TGL	RW	ASYNCH12 Port/Pin Select
0x35E8	GPIO_PRS0_ASYNC13ROUTE_TGL	RW	ASYNCH13 Port/Pin Select
0x35EC	GPIO_PRS0_ASYNC14ROUTE_TGL	RW	ASYNCH14 Port/Pin Select
0x35F0	GPIO_PRS0_ASYNC15ROUTE_TGL	RW	ASYNCH15 Port/Pin Select
0x35F4	GPIO_PRS0_SYNC0ROUTE_TGL	RW	SYNCH0 Port/Pin Select
0x35F8	GPIO_PRS0_SYNC1ROUTE_TGL	RW	SYNCH1 Port/Pin Select
0x35FC	GPIO_PRS0_SYNC2ROUTE_TGL	RW	SYNCH2 Port/Pin Select

Offset	Name	Type	Description
0x3600	GPIO_PRS0_SYNCH3ROUTE_TGL	RW	SYNCH3 Port/Pin Select
0x3608	GPIO_RAC_ROUTEEN_TGL	RW	RAC Pin Enable
0x360C	GPIO_RAC_LNAEN-ROUTE_TGL	RW	LNAEN Port/Pin Select
0x3610	GPIO_RAC_PAENROUTE_TGL	RW	PAEN Port/Pin Select
0x3678	GPIO_SYX00_BUFOUTREQINASYNCROUTE_TGL	RW	BUFOUTREQINASYNC Port/Pin Select
0x3680	GPIO_TIMER0_ROUTEEN_TGL	RW	TIMER0 Pin Enable
0x3684	GPIO_TIMER0_CC0ROUTE_TGL	RW	CC0 Port/Pin Select
0x3688	GPIO_TIMER0_CC1ROUTE_TGL	RW	CC1 Port/Pin Select
0x368C	GPIO_TIMER0_CC2ROUTE_TGL	RW	CC2 Port/Pin Select
0x3690	GPIO_TIMER0_CDTI0ROUTE_TGL	RW	CDTI0 Port/Pin Select
0x3694	GPIO_TIMER0_CDTI1ROUTE_TGL	RW	CDTI1 Port/Pin Select
0x3698	GPIO_TIMER0_CDTI2ROUTE_TGL	RW	CDTI2 Port/Pin Select
0x36A0	GPIO_TIMER1_ROUTEEN_TGL	RW	TIMER1 Pin Enable
0x36A4	GPIO_TIMER1_CC0ROUTE_TGL	RW	CC0 Port/Pin Select
0x36A8	GPIO_TIMER1_CC1ROUTE_TGL	RW	CC1 Port/Pin Select
0x36AC	GPIO_TIMER1_CC2ROUTE_TGL	RW	CC2 Port/Pin Select
0x36B0	GPIO_TIMER1_CDTI0ROUTE_TGL	RW	CDTI0 Port/Pin Select
0x36B4	GPIO_TIMER1_CDTI1ROUTE_TGL	RW	CDTI1 Port/Pin Select
0x36B8	GPIO_TIMER1_CDTI2ROUTE_TGL	RW	CDTI2 Port/Pin Select
0x36C0	GPIO_TIMER2_ROUTEEN_TGL	RW	TIMER2 Pin Enable
0x36C4	GPIO_TIMER2_CC0ROUTE_TGL	RW	CC0 Port/Pin Select
0x36C8	GPIO_TIMER2_CC1ROUTE_TGL	RW	CC1 Port/Pin Select
0x36CC	GPIO_TIMER2_CC2ROUTE_TGL	RW	CC2 Port/Pin Select
0x36D0	GPIO_TIMER2_CDTI0ROUTE_TGL	RW	CDTI0 Port/Pin Select
0x36D4	GPIO_TIMER2_CDTI1ROUTE_TGL	RW	CDTI1 Port/Pin Select

Offset	Name	Type	Description
0x36D8	GPIO_TIMER2_CDTI2ROUTE_TGL	RW	CDTI2 Port/Pin Select
0x36E0	GPIO_TIMER3_ROUTEEN_TGL	RW	TIMER3 Pin Enable
0x36E4	GPIO_TIMER3_CC0ROUTE_TGL	RW	CC0 Port/Pin Select
0x36E8	GPIO_TIMER3_CC1ROUTE_TGL	RW	CC1 Port/Pin Select
0x36EC	GPIO_TIMER3_CC2ROUTE_TGL	RW	CC2 Port/Pin Select
0x36F0	GPIO_TIMER3_CDTI0ROUTE_TGL	RW	CDTI0 Port/Pin Select
0x36F4	GPIO_TIMER3_CDTI1ROUTE_TGL	RW	CDTI1 Port/Pin Select
0x36F8	GPIO_TIMER3_CDTI2ROUTE_TGL	RW	CDTI2 Port/Pin Select
0x3700	GPIO_TIMER4_ROUTEEN_TGL	RW	TIMER4 Pin Enable
0x3704	GPIO_TIMER4_CC0ROUTE_TGL	RW	CC0 Port/Pin Select
0x3708	GPIO_TIMER4_CC1ROUTE_TGL	RW	CC1 Port/Pin Select
0x370C	GPIO_TIMER4_CC2ROUTE_TGL	RW	CC2 Port/Pin Select
0x3710	GPIO_TIMER4_CDTI0ROUTE_TGL	RW	CDTI0 Port/Pin Select
0x3714	GPIO_TIMER4_CDTI1ROUTE_TGL	RW	CDTI1 Port/Pin Select
0x3718	GPIO_TIMER4_CDTI2ROUTE_TGL	RW	CDTI2 Port/Pin Select
0x3720	GPIO_USART0_ROUTEEN_TGL	RW	USART0 Pin Enable
0x3724	GPIO_USART0_CSROUTE_TGL	RW	CS Port/Pin Select
0x3728	GPIO_USART0_CTSROUTE_TGL	RW	CTS Port/Pin Select
0x372C	GPIO_USART0_RTSROUTE_TGL	RW	RTS Port/Pin Select
0x3730	GPIO_USART0_RXROUTE_TGL	RW	RX Port/Pin Select
0x3734	GPIO_USART0_CLKROUTE_TGL	RW	SCLK Port/Pin Select
0x3738	GPIO_USART0_TXROUTE_TGL	RW	TX Port/Pin Select

24.6 GPIO Register Description

24.6.1 GPIO_IPVERSION - Main

Offset	Bit Position																															
0x000	31	30	29	28	27	26	25	24	23	22	21	20	19	18	17	16	15	14	13	12	11	10	9	8	7	6	5	4	3	2	1	0
Reset	0x3																															
Access	R																															
Name	IPVERSION																															

Bit	Name	Reset	Access	Description
31:0	IPVERSION IPVERSION ID	0x3	R	ip version id

24.6.2 GPIO_PORTA_CTRL - Port Control

Offset	Bit Position																																					
0x030	31	30	29	28	27	26	25	24	23	22	21	20	19	18	17	16	15	14	13	12	11	10	9	8	7	6	5	4	3	2	1	0						
Reset				0x0								0x4												0x0								0x4						
Access				RW								RW												RW								RW						
Name				DINDISALT								SLEWRATEALT												DINDIS								SLEWRATE						

Bit	Name	Reset	Access	Description
31:29	Reserved	To ensure compatibility with future devices, always write Reserved bits to their reset value, unless otherwise stated. More information in 1.2 Conventions		
28	DINDISALT	0x0	RW	Data In Disable Alt Data input disable for port pins using alternate modes.
27:23	Reserved	To ensure compatibility with future devices, always write Reserved bits to their reset value, unless otherwise stated. More information in 1.2 Conventions		
22:20	SLEWRATEALT	0x4	RW	Slew Rate Alt Slewrates limit for port pins using alternate modes. Higher values represent faster slewrates.
19:13	Reserved	To ensure compatibility with future devices, always write Reserved bits to their reset value, unless otherwise stated. More information in 1.2 Conventions		
12	DINDIS	0x0	RW	Data In Disable Data input disable for port pins not using alternate modes.
11:7	Reserved	To ensure compatibility with future devices, always write Reserved bits to their reset value, unless otherwise stated. More information in 1.2 Conventions		
6:4	SLEWRATE	0x4	RW	Slew Rate Slewrates limit for port pins using not alternate modes. Higher values represent faster slewrates.
3:0	Reserved	To ensure compatibility with future devices, always write Reserved bits to their reset value, unless otherwise stated. More information in 1.2 Conventions		

24.6.3 GPIO_PORTA_MODEL - Mode Low

Offset	Bit Position																															
0x034	31	30	29	28	27	26	25	24	23	22	21	20	19	18	17	16	15	14	13	12	11	10	9	8	7	6	5	4	3	2	1	0
Reset	0x0				0x0				0x0				0x0				0x0				0x0				0x0							
Access	RW				RW				RW				RW				RW				RW				RW							
Name	MODE7				MODE6				MODE5				MODE4				MODE3				MODE2				MODE1				MODE0			

Bit	Name	Reset	Access	Description
31:28	MODE7 MODE n	0x0	RW	MODE n
	Value	Mode		Description
	0	DISABLED		Input disabled. Pullup if DOUT is set.
	1	INPUT		Input enabled. Filter if DOUT is set.
	2	INPUTPULL		Input enabled. DOUT determines pull direction.
	3	INPUTPULLFILTER		Input enabled with filter. DOUT determines pull direction.
	4	PUSHPULL		Push-pull output.
	5	PUSHPULLALT		Push-pull using alternate control.
	6	WIREDOR		Wired-or output.
	7	WIREDORPULLDOWN		Wired-or output with pull-down.
	8	WIREDAND		Open-drain output.
	9	WIREDANDFILTER		Open-drain output with filter.
	10	WIREDANDPULLUP		Open-drain output with pullup.
	11	WIREDANDPULLUPFILTER		Open-drain output with filter and pullup.
	12	WIREDANDALT		Open-drain output using alternate control.
	13	WIREDANDALTFILTER		Open-drain output using alternate control with filter.
	14	WIREDANDALTPULLUP		Open-drain output using alternate control with pullup.
	15	WIREDANDALTPULLUPFILTER		Open-drain output using alternate control with filter and pullup.
27:24	MODE6 MODE n	0x0	RW	MODE n
	Value	Mode		Description
	0	DISABLED		Input disabled. Pullup if DOUT is set.
	1	INPUT		Input enabled. Filter if DOUT is set.
	2	INPUTPULL		Input enabled. DOUT determines pull direction.
	3	INPUTPULLFILTER		Input enabled with filter. DOUT determines pull direction.

Bit	Name	Reset	Access	Description
	4	PUSHPULL		Push-pull output.
	5	PUSHPULLALT		Push-pull using alternate control.
	6	WIREDOR		Wired-or output.
	7	WIREDORPULLDOWN		Wired-or output with pull-down.
	8	WIREDAND		Open-drain output.
	9	WIREDANDFILTER		Open-drain output with filter.
	10	WIREDANDPULLUP		Open-drain output with pullup.
	11	WIREDANDPULLUPFILTER		Open-drain output with filter and pullup.
	12	WIREDANDALT		Open-drain output using alternate control.
	13	WIREDANDALTFILTER		Open-drain output using alternate control with filter.
	14	WIREDANDALTPULLUP		Open-drain output using alternate control with pullup.
	15	WIREDANDALTPULLUPFILTER		Open-drain output using alternate control with filter and pullup.
23:20	MODE5 MODE n	0x0	RW	MODE n
	Value	Mode		Description
	0	DISABLED		Input disabled. Pullup if DOUT is set.
	1	INPUT		Input enabled. Filter if DOUT is set.
	2	INPUTPULL		Input enabled. DOUT determines pull direction.
	3	INPUTPULLFILTER		Input enabled with filter. DOUT determines pull direction.
	4	PUSHPULL		Push-pull output.
	5	PUSHPULLALT		Push-pull using alternate control.
	6	WIREDOR		Wired-or output.
	7	WIREDORPULLDOWN		Wired-or output with pull-down.
	8	WIREDAND		Open-drain output.
	9	WIREDANDFILTER		Open-drain output with filter.
	10	WIREDANDPULLUP		Open-drain output with pullup.
	11	WIREDANDPULLUPFILTER		Open-drain output with filter and pullup.
	12	WIREDANDALT		Open-drain output using alternate control.
	13	WIREDANDALTFILTER		Open-drain output using alternate control with filter.
	14	WIREDANDALTPULLUP		Open-drain output using alternate control with pullup.
	15	WIREDANDALTPULLUPFILTER		Open-drain output using alternate control with filter and pullup.
19:16	MODE4 MODE n	0x0	RW	MODE n

Bit	Name	Reset	Access	Description
	Value	Mode		Description
	0	DISABLED		Input disabled. Pullup if DOUT is set.
	1	INPUT		Input enabled. Filter if DOUT is set.
	2	INPUTPULL		Input enabled. DOUT determines pull direction.
	3	INPUTPULLFILTER		Input enabled with filter. DOUT determines pull direction.
	4	PUSHPULL		Push-pull output.
	5	PUSHPULLALT		Push-pull using alternate control.
	6	WIREDOR		Wired-or output.
	7	WIREDORPULLDOWN		Wired-or output with pull-down.
	8	WIREDAND		Open-drain output.
	9	WIREDANDFILTER		Open-drain output with filter.
	10	WIREDANDPULLUP		Open-drain output with pullup.
	11	WIREDANDPULLUPFILTER		Open-drain output with filter and pullup.
	12	WIREDANDALT		Open-drain output using alternate control.
	13	WIREDANDALTFILTER		Open-drain output using alternate control with filter.
	14	WIREDANDALTPULLUP		Open-drain output using alternate control with pullup.
	15	WIREDANDALTPULLUPFILTER		Open-drain output using alternate control with filter and pullup.
15:12	MODE3	0x0	RW	MODE n
	MODE n			
	Value	Mode		Description
	0	DISABLED		Input disabled. Pullup if DOUT is set.
	1	INPUT		Input enabled. Filter if DOUT is set.
	2	INPUTPULL		Input enabled. DOUT determines pull direction.
	3	INPUTPULLFILTER		Input enabled with filter. DOUT determines pull direction.
	4	PUSHPULL		Push-pull output.
	5	PUSHPULLALT		Push-pull using alternate control.
	6	WIREDOR		Wired-or output.
	7	WIREDORPULLDOWN		Wired-or output with pull-down.
	8	WIREDAND		Open-drain output.
	9	WIREDANDFILTER		Open-drain output with filter.
	10	WIREDANDPULLUP		Open-drain output with pullup.
	11	WIREDANDPULLUPFILTER		Open-drain output with filter and pullup.
	12	WIREDANDALT		Open-drain output using alternate control.
	13	WIREDANDALTFILTER		Open-drain output using alternate control with filter.
	14	WIREDANDALTPULLUP		Open-drain output using alternate control with pullup.

Bit	Name	Reset	Access	Description
	15	WIREDANDALTPULLUP-FILTER		Open-drain output using alternate control with filter and pullup.
11:8	MODE2 MODE n	0x0	RW	MODE n
	Value	Mode		Description
	0	DISABLED		Input disabled. Pullup if DOUT is set.
	1	INPUT		Input enabled. Filter if DOUT is set.
	2	INPUTPULL		Input enabled. DOUT determines pull direction.
	3	INPUTPULLFILTER		Input enabled with filter. DOUT determines pull direction.
	4	PUSHPULL		Push-pull output.
	5	PUSHPULLALT		Push-pull using alternate control.
	6	WIREDOR		Wired-or output.
	7	WIREDORPULLDOWN		Wired-or output with pull-down.
	8	WIREDAND		Open-drain output.
	9	WIREDANDFILTER		Open-drain output with filter.
	10	WIREDANDPULLUP		Open-drain output with pullup.
	11	WIREDANDPULLUPFILTER		Open-drain output with filter and pullup.
	12	WIREDANDALT		Open-drain output using alternate control.
	13	WIREDANDALTFILTER		Open-drain output using alternate control with filter.
	14	WIREDANDALTPULLUP		Open-drain output using alternate control with pullup.
	15	WIREDANDALTPULLUP-FILTER		Open-drain output using alternate control with filter and pullup.
7:4	MODE1 MODE n	0x0	RW	MODE n
	Value	Mode		Description
	0	DISABLED		Input disabled. Pullup if DOUT is set.
	1	INPUT		Input enabled. Filter if DOUT is set.
	2	INPUTPULL		Input enabled. DOUT determines pull direction.
	3	INPUTPULLFILTER		Input enabled with filter. DOUT determines pull direction.
	4	PUSHPULL		Push-pull output.
	5	PUSHPULLALT		Push-pull using alternate control.
	6	WIREDOR		Wired-or output.
	7	WIREDORPULLDOWN		Wired-or output with pull-down.
	8	WIREDAND		Open-drain output.
	9	WIREDANDFILTER		Open-drain output with filter.
	10	WIREDANDPULLUP		Open-drain output with pullup.

Bit	Name	Reset	Access	Description
11		WIREDANDPULLUPFILTER		Open-drain output with filter and pullup.
12		WIREDANDALT		Open-drain output using alternate control.
13		WIREDANDALTFILTER		Open-drain output using alternate control with filter.
14		WIREDANDALTPULLUP		Open-drain output using alternate control with pullup.
15		WIREDANDALTPULLUPFILTER		Open-drain output using alternate control with filter and pullup.
3:0	MODE0 MODE n	0x0	RW	MODE n
	Value	Mode		Description
	0	DISABLED		Input disabled. Pullup if DOUT is set.
	1	INPUT		Input enabled. Filter if DOUT is set.
	2	INPUTPULL		Input enabled. DOUT determines pull direction.
	3	INPUTPULLFILTER		Input enabled with filter. DOUT determines pull direction.
	4	PUSHPULL		Push-pull output.
	5	PUSHPULLALT		Push-pull using alternate control.
	6	WIREDOR		Wired-or output.
	7	WIREDORPULLDOWN		Wired-or output with pull-down.
	8	WIREDAND		Open-drain output.
	9	WIREDANDFILTER		Open-drain output with filter.
	10	WIREDANDPULLUP		Open-drain output with pullup.
	11	WIREDANDPULLUPFILTER		Open-drain output with filter and pullup.
	12	WIREDANDALT		Open-drain output using alternate control.
	13	WIREDANDALTFILTER		Open-drain output using alternate control with filter.
	14	WIREDANDALTPULLUP		Open-drain output using alternate control with pullup.
	15	WIREDANDALTPULLUPFILTER		Open-drain output using alternate control with filter and pullup.

24.6.4 GPIO_PORTA_MODEH - Mode High

Offset	Bit Position																															
0x03C	31	30	29	28	27	26	25	24	23	22	21	20	19	18	17	16	15	14	13	12	11	10	9	8	7	6	5	4	3	2	1	0
Reset																									0x0				0x0			
Access																									RW				RW			
Name																									MODE1				MODE0			

Bit	Name	Reset	Access	Description
31:8	<i>Reserved</i>	<i>To ensure compatibility with future devices, always write Reserved bits to their reset value, unless otherwise stated. More information in 1.2 Conventions</i>		
7:4	MODE1 MODE n	0x0	RW	MODE n
	Value	Mode		Description
	0	DISABLED		Input disabled. Pullup if DOUT is set.
	1	INPUT		Input enabled. Filter if DOUT is set.
	2	INPUTPULL		Input enabled. DOUT determines pull direction.
	3	INPUTPULLFILTER		Input enabled with filter. DOUT determines pull direction.
	4	PUSHPULL		Push-pull output.
	5	PUSHPULLALT		Push-pull using alternate control.
	6	WIREDOR		Wired-or output.
	7	WIREDORPULLDOWN		Wired-or output with pull-down.
	8	WIREDAND		Open-drain output.
	9	WIREDANDFILTER		Open-drain output with filter.
	10	WIREDANDPULLUP		Open-drain output with pullup.
	11	WIREDANDPULLUPFILTER		Open-drain output with filter and pullup.
	12	WIREDANDALT		Open-drain output using alternate control.
	13	WIREDANDALTFILTER		Open-drain output using alternate control with filter.
	14	WIREDANDALTPULLUP		Open-drain output using alternate control with pullup.
	15	WIREDANDALTPULLUPFILTER		Open-drain output using alternate control with filter and pullup.
3:0	MODE0 MODE n	0x0	RW	MODE n
	Value	Mode		Description
	0	DISABLED		Input disabled. Pullup if DOUT is set.
	1	INPUT		Input enabled. Filter if DOUT is set.
	2	INPUTPULL		Input enabled. DOUT determines pull direction.

Bit	Name	Reset	Access	Description
3		INPUTPULLFILTER		Input enabled with filter. DOUT determines pull direction.
4		PUSHPULL		Push-pull output.
5		PUSHPULLALT		Push-pull using alternate control.
6		WIREDOR		Wired-or output.
7		WIREDORPULLDOWN		Wired-or output with pull-down.
8		WIREDAND		Open-drain output.
9		WIREDANDFILTER		Open-drain output with filter.
10		WIREDANDPULLUP		Open-drain output with pullup.
11		WIREDANDPULLUPFILTER		Open-drain output with filter and pullup.
12		WIREDANDALT		Open-drain output using alternate control.
13		WIREDANDALTFILTER		Open-drain output using alternate control with filter.
14		WIREDANDALTPULLUP		Open-drain output using alternate control with pullup.
15		WIREDANDALTPULLUPFILTER		Open-drain output using alternate control with filter and pullup.

24.6.5 GPIO_PORTA_DOUT - Data Out

Offset	Bit Position																															
0x040	31	30	29	28	27	26	25	24	23	22	21	20	19	18	17	16	15	14	13	12	11	10	9	8	7	6	5	4	3	2	1	0
Reset																									0x0							
Access																									RW							
Name																									DOUT							

Bit	Name	Reset	Access	Description
31:10	Reserved	<i>To ensure compatibility with future devices, always write Reserved bits to their reset value, unless otherwise stated. More information in 1.2 Conventions</i>		
9:0	DOUT Data output	0x0	RW	Data output

24.6.6 GPIO_PORTA_DIN - Data in

Offset	Bit Position																															
0x044	31	30	29	28	27	26	25	24	23	22	21	20	19	18	17	16	15	14	13	12	11	10	9	8	7	6	5	4	3	2	1	0
Reset																	0x0															
Access																	R															
Name																	DIN															

Bit	Name	Reset	Access	Description
31:10	Reserved	To ensure compatibility with future devices, always write Reserved bits to their reset value, unless otherwise stated. More information in 1.2 Conventions		
9:0	DIN Data input	0x0	R	Data input

24.6.7 GPIO_PORTB_CTRL - Port Control

Offset	Bit Position																																
0x060	31	30	29	28	27	26	25	24	23	22	21	20	19	18	17	16	15	14	13	12	11	10	9	8	7	6	5	4	3	2	1	0	
Reset				0x0							0x4												0x0							0x4			
Access				RW							RW												RW							RW			
Name				DINDISALT							SLEWRATEALT												DINDIS							SLEWRATE			

Bit	Name	Reset	Access	Description
31:29	Reserved	To ensure compatibility with future devices, always write Reserved bits to their reset value, unless otherwise stated. More information in 1.2 Conventions		
28	DINDISALT	0x0	RW	Data In Disable Alt Data input disable for port pins using alternate modes.
27:23	Reserved	To ensure compatibility with future devices, always write Reserved bits to their reset value, unless otherwise stated. More information in 1.2 Conventions		
22:20	SLEWRATEALT	0x4	RW	Slew Rate Alt Slewrates limit for port pins using alternate modes. Higher values represent faster slewrates.
19:13	Reserved	To ensure compatibility with future devices, always write Reserved bits to their reset value, unless otherwise stated. More information in 1.2 Conventions		
12	DINDIS	0x0	RW	Data In Disable Data input disable for port pins not using alternate modes.
11:7	Reserved	To ensure compatibility with future devices, always write Reserved bits to their reset value, unless otherwise stated. More information in 1.2 Conventions		
6:4	SLEWRATE	0x4	RW	Slew Rate Slewrates limit for port pins using not alternate modes. Higher values represent faster slewrates.
3:0	Reserved	To ensure compatibility with future devices, always write Reserved bits to their reset value, unless otherwise stated. More information in 1.2 Conventions		

24.6.8 GPIO_PORTB_MODEL - Mode Low

Offset	Bit Position																															
0x064	31	30	29	28	27	26	25	24	23	22	21	20	19	18	17	16	15	14	13	12	11	10	9	8	7	6	5	4	3	2	1	0
Reset									0x0				0x0				0x0				0x0				0x0							
Access									RW				RW				RW				RW				RW							
Name									MODE5				MODE4				MODE3				MODE2				MODE1				MODE0			

Bit	Name	Reset	Access	Description
31:24	<i>Reserved</i>	<i>To ensure compatibility with future devices, always write Reserved bits to their reset value, unless otherwise stated. More information in 1.2 Conventions</i>		
23:20	MODE5 MODE n	0x0	RW	MODE n
	Value	Mode		Description
	0	DISABLED		Input disabled. Pullup if DOUT is set.
	1	INPUT		Input enabled. Filter if DOUT is set.
	2	INPUTPULL		Input enabled. DOUT determines pull direction.
	3	INPUTPULLFILTER		Input enabled with filter. DOUT determines pull direction.
	4	PUSHPULL		Push-pull output.
	5	PUSHPULLALT		Push-pull using alternate control.
	6	WIREDOR		Wired-or output.
	7	WIREDORPULLDOWN		Wired-or output with pull-down.
	8	WIREDAND		Open-drain output.
	9	WIREDANDFILTER		Open-drain output with filter.
	10	WIREDANDPULLUP		Open-drain output with pullup.
	11	WIREDANDPULLUPFILTER		Open-drain output with filter and pullup.
	12	WIREDANDALT		Open-drain output using alternate control.
	13	WIREDANDALTFILTER		Open-drain output using alternate control with filter.
	14	WIREDANDALTPULLUP		Open-drain output using alternate control with pullup.
	15	WIREDANDALTPULLUPFILTER		Open-drain output using alternate control with filter and pullup.
19:16	MODE4 MODE n	0x0	RW	MODE n
	Value	Mode		Description
	0	DISABLED		Input disabled. Pullup if DOUT is set.
	1	INPUT		Input enabled. Filter if DOUT is set.
	2	INPUTPULL		Input enabled. DOUT determines pull direction.

Bit	Name	Reset	Access	Description
	3	INPUTPULLFILTER		Input enabled with filter. DOUT determines pull direction.
	4	PUSHPULL		Push-pull output.
	5	PUSHPULLALT		Push-pull using alternate control.
	6	WIREDOR		Wired-or output.
	7	WIREDORPULLDOWN		Wired-or output with pull-down.
	8	WIREDAND		Open-drain output.
	9	WIREDANDFILTER		Open-drain output with filter.
	10	WIREDANDPULLUP		Open-drain output with pullup.
	11	WIREDANDPULLUPFILTER		Open-drain output with filter and pullup.
	12	WIREDANDALT		Open-drain output using alternate control.
	13	WIREDANDALTFILTER		Open-drain output using alternate control with filter.
	14	WIREDANDALTPULLUP		Open-drain output using alternate control with pullup.
	15	WIREDANDALTPULLUPFILTER		Open-drain output using alternate control with filter and pullup.
15:12	MODE3 MODE n	0x0	RW	MODE n
	Value	Mode		Description
	0	DISABLED		Input disabled. Pullup if DOUT is set.
	1	INPUT		Input enabled. Filter if DOUT is set.
	2	INPUTPULL		Input enabled. DOUT determines pull direction.
	3	INPUTPULLFILTER		Input enabled with filter. DOUT determines pull direction.
	4	PUSHPULL		Push-pull output.
	5	PUSHPULLALT		Push-pull using alternate control.
	6	WIREDOR		Wired-or output.
	7	WIREDORPULLDOWN		Wired-or output with pull-down.
	8	WIREDAND		Open-drain output.
	9	WIREDANDFILTER		Open-drain output with filter.
	10	WIREDANDPULLUP		Open-drain output with pullup.
	11	WIREDANDPULLUPFILTER		Open-drain output with filter and pullup.
	12	WIREDANDALT		Open-drain output using alternate control.
	13	WIREDANDALTFILTER		Open-drain output using alternate control with filter.
	14	WIREDANDALTPULLUP		Open-drain output using alternate control with pullup.
	15	WIREDANDALTPULLUPFILTER		Open-drain output using alternate control with filter and pullup.
11:8	MODE2 MODE n	0x0	RW	MODE n

Bit	Name	Reset	Access	Description
	Value	Mode		Description
	0	DISABLED		Input disabled. Pullup if DOUT is set.
	1	INPUT		Input enabled. Filter if DOUT is set.
	2	INPUTPULL		Input enabled. DOUT determines pull direction.
	3	INPUTPULLFILTER		Input enabled with filter. DOUT determines pull direction.
	4	PUSHPULL		Push-pull output.
	5	PUSHPULLALT		Push-pull using alternate control.
	6	WIREDOR		Wired-or output.
	7	WIREDORPULLDOWN		Wired-or output with pull-down.
	8	WIREDAND		Open-drain output.
	9	WIREDANDFILTER		Open-drain output with filter.
	10	WIREDANDPULLUP		Open-drain output with pullup.
	11	WIREDANDPULLUPFILTER		Open-drain output with filter and pullup.
	12	WIREDANDALT		Open-drain output using alternate control.
	13	WIREDANDALTFILTER		Open-drain output using alternate control with filter.
	14	WIREDANDALTPULLUP		Open-drain output using alternate control with pullup.
	15	WIREDANDALTPULLUPFILTER		Open-drain output using alternate control with filter and pullup.
7:4	MODE1 MODE n	0x0	RW	MODE n
	Value	Mode		Description
	0	DISABLED		Input disabled. Pullup if DOUT is set.
	1	INPUT		Input enabled. Filter if DOUT is set.
	2	INPUTPULL		Input enabled. DOUT determines pull direction.
	3	INPUTPULLFILTER		Input enabled with filter. DOUT determines pull direction.
	4	PUSHPULL		Push-pull output.
	5	PUSHPULLALT		Push-pull using alternate control.
	6	WIREDOR		Wired-or output.
	7	WIREDORPULLDOWN		Wired-or output with pull-down.
	8	WIREDAND		Open-drain output.
	9	WIREDANDFILTER		Open-drain output with filter.
	10	WIREDANDPULLUP		Open-drain output with pullup.
	11	WIREDANDPULLUPFILTER		Open-drain output with filter and pullup.
	12	WIREDANDALT		Open-drain output using alternate control.
	13	WIREDANDALTFILTER		Open-drain output using alternate control with filter.

Bit	Name	Reset	Access	Description
	14	WIREDANDALTPULLUP		Open-drain output using alternate control with pullup.
	15	WIREDANDALTPULLUP-FILTER		Open-drain output using alternate control with filter and pullup.
3:0	MODE0 MODE n	0x0	RW	MODE n
	Value	Mode		Description
	0	DISABLED		Input disabled. Pullup if DOUT is set.
	1	INPUT		Input enabled. Filter if DOUT is set.
	2	INPUTPULL		Input enabled. DOUT determines pull direction.
	3	INPUTPULLFILTER		Input enabled with filter. DOUT determines pull direction.
	4	PUSHPULL		Push-pull output.
	5	PUSHPULLALT		Push-pull using alternate control.
	6	WIREDOR		Wired-or output.
	7	WIREDORPULLDOWN		Wired-or output with pull-down.
	8	WIREDAND		Open-drain output.
	9	WIREDANDFILTER		Open-drain output with filter.
	10	WIREDANDPULLUP		Open-drain output with pullup.
	11	WIREDANDPULLUPFILTER		Open-drain output with filter and pullup.
	12	WIREDANDALT		Open-drain output using alternate control.
	13	WIREDANDALTFILTER		Open-drain output using alternate control with filter.
	14	WIREDANDALTPULLUP		Open-drain output using alternate control with pullup.
	15	WIREDANDALTPULLUP-FILTER		Open-drain output using alternate control with filter and pullup.

24.6.9 GPIO_PORTB_DOUT - Data Out

Offset	Bit Position																															
0x070	31	30	29	28	27	26	25	24	23	22	21	20	19	18	17	16	15	14	13	12	11	10	9	8	7	6	5	4	3	2	1	0
Reset																											0x0					
Access																											RW					
Name																											DOUT					

Bit	Name	Reset	Access	Description
31:6	<i>Reserved</i>	<i>To ensure compatibility with future devices, always write Reserved bits to their reset value, unless otherwise stated. More information in 1.2 Conventions</i>		
5:0	DOUT Data output	0x0	RW	Data output

24.6.10 GPIO_PORTB_DIN - Data in

Offset	Bit Position																															
0x074	31	30	29	28	27	26	25	24	23	22	21	20	19	18	17	16	15	14	13	12	11	10	9	8	7	6	5	4	3	2	1	0
Reset																											0x0					
Access																											R					
Name																											DIN					

Bit	Name	Reset	Access	Description
31:6	Reserved	<i>To ensure compatibility with future devices, always write Reserved bits to their reset value, unless otherwise stated. More information in 1.2 Conventions</i>		
5:0	DIN Data input	0x0	R	Data input

24.6.11 GPIO_PORTC_CTRL - Port Control

Offset	Bit Position																																		
0x090	31	30	29	28	27	26	25	24	23	22	21	20	19	18	17	16	15	14	13	12	11	10	9	8	7	6	5	4	3	2	1	0			
Reset				0x0								0x4												0x0								0x4			
Access				RW								RW												RW								RW			
Name				DINDISALT								SLEWRATEALT												DINDIS								SLEWRATE			

Bit	Name	Reset	Access	Description
31:29	Reserved			To ensure compatibility with future devices, always write Reserved bits to their reset value, unless otherwise stated. More information in 1.2 Conventions
28	DINDISALT	0x0	RW	Data In Disable Alt Data input disable for port pins using alternate modes.
27:23	Reserved			To ensure compatibility with future devices, always write Reserved bits to their reset value, unless otherwise stated. More information in 1.2 Conventions
22:20	SLEWRATEALT	0x4	RW	Slew Rate Alt Slewrates limit for port pins using alternate modes. Higher values represent faster slewrates.
19:13	Reserved			To ensure compatibility with future devices, always write Reserved bits to their reset value, unless otherwise stated. More information in 1.2 Conventions
12	DINDIS	0x0	RW	Data In Disable Data input disable for port pins not using alternate modes.
11:7	Reserved			To ensure compatibility with future devices, always write Reserved bits to their reset value, unless otherwise stated. More information in 1.2 Conventions
6:4	SLEWRATE	0x4	RW	Slew Rate Slewrates limit for port pins using not alternate modes. Higher values represent faster slewrates.
3:0	Reserved			To ensure compatibility with future devices, always write Reserved bits to their reset value, unless otherwise stated. More information in 1.2 Conventions

24.6.12 GPIO_PORTC_MODEL - Mode Low

Offset	Bit Position																															
0x094	31	30	29	28	27	26	25	24	23	22	21	20	19	18	17	16	15	14	13	12	11	10	9	8	7	6	5	4	3	2	1	0
Reset	0x0				0x0				0x0				0x0				0x0				0x0				0x0							
Access	RW				RW				RW				RW				RW				RW				RW							
Name	MODE7				MODE6				MODE5				MODE4				MODE3				MODE2				MODE1				MODE0			

Bit	Name	Reset	Access	Description
31:28	MODE7 MODE n	0x0	RW	MODE n
	Value	Mode		Description
	0	DISABLED		Input disabled. Pullup if DOUT is set.
	1	INPUT		Input enabled. Filter if DOUT is set.
	2	INPUTPULL		Input enabled. DOUT determines pull direction.
	3	INPUTPULLFILTER		Input enabled with filter. DOUT determines pull direction.
	4	PUSHPULL		Push-pull output.
	5	PUSHPULLALT		Push-pull using alternate control.
	6	WIREDOR		Wired-or output.
	7	WIREDORPULLDOWN		Wired-or output with pull-down.
	8	WIREDAND		Open-drain output.
	9	WIREDANDFILTER		Open-drain output with filter.
	10	WIREDANDPULLUP		Open-drain output with pullup.
	11	WIREDANDPULLUPFILTER		Open-drain output with filter and pullup.
	12	WIREDANDALT		Open-drain output using alternate control.
	13	WIREDANDALTFILTER		Open-drain output using alternate control with filter.
	14	WIREDANDALTPULLUP		Open-drain output using alternate control with pullup.
	15	WIREDANDALTPULLUPFILTER		Open-drain output using alternate control with filter and pullup.
27:24	MODE6 MODE n	0x0	RW	MODE n
	Value	Mode		Description
	0	DISABLED		Input disabled. Pullup if DOUT is set.
	1	INPUT		Input enabled. Filter if DOUT is set.
	2	INPUTPULL		Input enabled. DOUT determines pull direction.
	3	INPUTPULLFILTER		Input enabled with filter. DOUT determines pull direction.

Bit	Name	Reset	Access	Description
	4	PUSHPULL		Push-pull output.
	5	PUSHPULLALT		Push-pull using alternate control.
	6	WIREDOR		Wired-or output.
	7	WIREDORPULLDOWN		Wired-or output with pull-down.
	8	WIREDAND		Open-drain output.
	9	WIREDANDFILTER		Open-drain output with filter.
	10	WIREDANDPULLUP		Open-drain output with pullup.
	11	WIREDANDPULLUPFILTER		Open-drain output with filter and pullup.
	12	WIREDANDALT		Open-drain output using alternate control.
	13	WIREDANDALTFILTER		Open-drain output using alternate control with filter.
	14	WIREDANDALTPULLUP		Open-drain output using alternate control with pullup.
	15	WIREDANDALTPULLUPFILTER		Open-drain output using alternate control with filter and pullup.
23:20	MODE5 MODE n	0x0	RW	MODE n
	Value	Mode		Description
	0	DISABLED		Input disabled. Pullup if DOUT is set.
	1	INPUT		Input enabled. Filter if DOUT is set.
	2	INPUTPULL		Input enabled. DOUT determines pull direction.
	3	INPUTPULLFILTER		Input enabled with filter. DOUT determines pull direction.
	4	PUSHPULL		Push-pull output.
	5	PUSHPULLALT		Push-pull using alternate control.
	6	WIREDOR		Wired-or output.
	7	WIREDORPULLDOWN		Wired-or output with pull-down.
	8	WIREDAND		Open-drain output.
	9	WIREDANDFILTER		Open-drain output with filter.
	10	WIREDANDPULLUP		Open-drain output with pullup.
	11	WIREDANDPULLUPFILTER		Open-drain output with filter and pullup.
	12	WIREDANDALT		Open-drain output using alternate control.
	13	WIREDANDALTFILTER		Open-drain output using alternate control with filter.
	14	WIREDANDALTPULLUP		Open-drain output using alternate control with pullup.
	15	WIREDANDALTPULLUPFILTER		Open-drain output using alternate control with filter and pullup.
19:16	MODE4 MODE n	0x0	RW	MODE n

Bit	Name	Reset	Access	Description
	Value	Mode		Description
	0	DISABLED		Input disabled. Pullup if DOUT is set.
	1	INPUT		Input enabled. Filter if DOUT is set.
	2	INPUTPULL		Input enabled. DOUT determines pull direction.
	3	INPUTPULLFILTER		Input enabled with filter. DOUT determines pull direction.
	4	PUSHPULL		Push-pull output.
	5	PUSHPULLALT		Push-pull using alternate control.
	6	WIREDOR		Wired-or output.
	7	WIREDORPULLDOWN		Wired-or output with pull-down.
	8	WIREDAND		Open-drain output.
	9	WIREDANDFILTER		Open-drain output with filter.
	10	WIREDANDPULLUP		Open-drain output with pullup.
	11	WIREDANDPULLUPFILTER		Open-drain output with filter and pullup.
	12	WIREDANDALT		Open-drain output using alternate control.
	13	WIREDANDALTFILTER		Open-drain output using alternate control with filter.
	14	WIREDANDALTPULLUP		Open-drain output using alternate control with pullup.
	15	WIREDANDALTPULLUPFILTER		Open-drain output using alternate control with filter and pullup.
15:12	MODE3	0x0	RW	MODE n
	MODE n			
	Value	Mode		Description
	0	DISABLED		Input disabled. Pullup if DOUT is set.
	1	INPUT		Input enabled. Filter if DOUT is set.
	2	INPUTPULL		Input enabled. DOUT determines pull direction.
	3	INPUTPULLFILTER		Input enabled with filter. DOUT determines pull direction.
	4	PUSHPULL		Push-pull output.
	5	PUSHPULLALT		Push-pull using alternate control.
	6	WIREDOR		Wired-or output.
	7	WIREDORPULLDOWN		Wired-or output with pull-down.
	8	WIREDAND		Open-drain output.
	9	WIREDANDFILTER		Open-drain output with filter.
	10	WIREDANDPULLUP		Open-drain output with pullup.
	11	WIREDANDPULLUPFILTER		Open-drain output with filter and pullup.
	12	WIREDANDALT		Open-drain output using alternate control.
	13	WIREDANDALTFILTER		Open-drain output using alternate control with filter.
	14	WIREDANDALTPULLUP		Open-drain output using alternate control with pullup.

Bit	Name	Reset	Access	Description
	15	WIREDANDALTPULLUP-FILTER		Open-drain output using alternate control with filter and pullup.
11:8	MODE2 MODE n	0x0	RW	MODE n
	Value	Mode		Description
	0	DISABLED		Input disabled. Pullup if DOUT is set.
	1	INPUT		Input enabled. Filter if DOUT is set.
	2	INPUTPULL		Input enabled. DOUT determines pull direction.
	3	INPUTPULLFILTER		Input enabled with filter. DOUT determines pull direction.
	4	PUSHPULL		Push-pull output.
	5	PUSHPULLALT		Push-pull using alternate control.
	6	WIREDOR		Wired-or output.
	7	WIREDORPULLDOWN		Wired-or output with pull-down.
	8	WIREDAND		Open-drain output.
	9	WIREDANDFILTER		Open-drain output with filter.
	10	WIREDANDPULLUP		Open-drain output with pullup.
	11	WIREDANDPULLUPFILTER		Open-drain output with filter and pullup.
	12	WIREDANDALT		Open-drain output using alternate control.
	13	WIREDANDALTFILTER		Open-drain output using alternate control with filter.
	14	WIREDANDALTPULLUP		Open-drain output using alternate control with pullup.
	15	WIREDANDALTPULLUP-FILTER		Open-drain output using alternate control with filter and pullup.
7:4	MODE1 MODE n	0x0	RW	MODE n
	Value	Mode		Description
	0	DISABLED		Input disabled. Pullup if DOUT is set.
	1	INPUT		Input enabled. Filter if DOUT is set.
	2	INPUTPULL		Input enabled. DOUT determines pull direction.
	3	INPUTPULLFILTER		Input enabled with filter. DOUT determines pull direction.
	4	PUSHPULL		Push-pull output.
	5	PUSHPULLALT		Push-pull using alternate control.
	6	WIREDOR		Wired-or output.
	7	WIREDORPULLDOWN		Wired-or output with pull-down.
	8	WIREDAND		Open-drain output.
	9	WIREDANDFILTER		Open-drain output with filter.
	10	WIREDANDPULLUP		Open-drain output with pullup.

Bit	Name	Reset	Access	Description
11		WIREDANDPULLUPFILTER		Open-drain output with filter and pullup.
12		WIREDANDALT		Open-drain output using alternate control.
13		WIREDANDALTFILTER		Open-drain output using alternate control with filter.
14		WIREDANDALTPULLUP		Open-drain output using alternate control with pullup.
15		WIREDANDALTPULLUPFILTER		Open-drain output using alternate control with filter and pullup.
3:0	MODE0 MODE n	0x0	RW	MODE n
	Value	Mode		Description
	0	DISABLED		Input disabled. Pullup if DOUT is set.
	1	INPUT		Input enabled. Filter if DOUT is set.
	2	INPUTPULL		Input enabled. DOUT determines pull direction.
	3	INPUTPULLFILTER		Input enabled with filter. DOUT determines pull direction.
	4	PUSHPULL		Push-pull output.
	5	PUSHPULLALT		Push-pull using alternate control.
	6	WIREDOR		Wired-or output.
	7	WIREDORPULLDOWN		Wired-or output with pull-down.
	8	WIREDAND		Open-drain output.
	9	WIREDANDFILTER		Open-drain output with filter.
	10	WIREDANDPULLUP		Open-drain output with pullup.
	11	WIREDANDPULLUPFILTER		Open-drain output with filter and pullup.
	12	WIREDANDALT		Open-drain output using alternate control.
	13	WIREDANDALTFILTER		Open-drain output using alternate control with filter.
	14	WIREDANDALTPULLUP		Open-drain output using alternate control with pullup.
	15	WIREDANDALTPULLUPFILTER		Open-drain output using alternate control with filter and pullup.

24.6.13 GPIO_PORTC_MODEH - Mode High

Offset	Bit Position																															
0x09C	31	30	29	28	27	26	25	24	23	22	21	20	19	18	17	16	15	14	13	12	11	10	9	8	7	6	5	4	3	2	1	0
Reset																									0x0				0x0			
Access																									RW				RW			
Name																									MODE1				MODE0			

Bit	Name	Reset	Access	Description
31:8	<i>Reserved</i>	<i>To ensure compatibility with future devices, always write Reserved bits to their reset value, unless otherwise stated. More information in 1.2 Conventions</i>		
7:4	MODE1 MODE n	0x0	RW	MODE n
	Value	Mode		Description
	0	DISABLED		Input disabled. Pullup if DOUT is set.
	1	INPUT		Input enabled. Filter if DOUT is set.
	2	INPUTPULL		Input enabled. DOUT determines pull direction.
	3	INPUTPULLFILTER		Input enabled with filter. DOUT determines pull direction.
	4	PUSHPULL		Push-pull output.
	5	PUSHPULLALT		Push-pull using alternate control.
	6	WIREDOR		Wired-or output.
	7	WIREDORPULLDOWN		Wired-or output with pull-down.
	8	WIREDAND		Open-drain output.
	9	WIREDANDFILTER		Open-drain output with filter.
	10	WIREDANDPULLUP		Open-drain output with pullup.
	11	WIREDANDPULLUPFILTER		Open-drain output with filter and pullup.
	12	WIREDANDALT		Open-drain output using alternate control.
	13	WIREDANDALTFILTER		Open-drain output using alternate control with filter.
	14	WIREDANDALTPULLUP		Open-drain output using alternate control with pullup.
	15	WIREDANDALTPULLUPFILTER		Open-drain output using alternate control with filter and pullup.
3:0	MODE0 MODE n	0x0	RW	MODE n
	Value	Mode		Description
	0	DISABLED		Input disabled. Pullup if DOUT is set.
	1	INPUT		Input enabled. Filter if DOUT is set.
	2	INPUTPULL		Input enabled. DOUT determines pull direction.

Bit	Name	Reset	Access	Description
3		INPUTPULLFILTER		Input enabled with filter. DOUT determines pull direction.
4		PUSHPULL		Push-pull output.
5		PUSHPULLALT		Push-pull using alternate control.
6		WIREDOR		Wired-or output.
7		WIREDORPULLDOWN		Wired-or output with pull-down.
8		WIREDAND		Open-drain output.
9		WIREDANDFILTER		Open-drain output with filter.
10		WIREDANDPULLUP		Open-drain output with pullup.
11		WIREDANDPULLUPFILTER		Open-drain output with filter and pullup.
12		WIREDANDALT		Open-drain output using alternate control.
13		WIREDANDALTFILTER		Open-drain output using alternate control with filter.
14		WIREDANDALTPULLUP		Open-drain output using alternate control with pullup.
15		WIREDANDALTPULLUPFILTER		Open-drain output using alternate control with filter and pullup.

24.6.14 GPIO_PORTC_DOUT - Data Out

Offset	Bit Position																															
0x0A0	31	30	29	28	27	26	25	24	23	22	21	20	19	18	17	16	15	14	13	12	11	10	9	8	7	6	5	4	3	2	1	0
Reset																									0x0							
Access																									RW							
Name																									DOUT							

Bit	Name	Reset	Access	Description
31:10	Reserved	<i>To ensure compatibility with future devices, always write Reserved bits to their reset value, unless otherwise stated. More information in 1.2 Conventions</i>		
9:0	DOUT Data output	0x0	RW	Data output

24.6.15 GPIO_PORTC_DIN - Data in

Offset	Bit Position																															
0x0A4	31	30	29	28	27	26	25	24	23	22	21	20	19	18	17	16	15	14	13	12	11	10	9	8	7	6	5	4	3	2	1	0
Reset																	0x0															
Access																	R															
Name																	DIN															

Bit	Name	Reset	Access	Description
31:10	Reserved	To ensure compatibility with future devices, always write Reserved bits to their reset value, unless otherwise stated. More information in 1.2 Conventions		
9:0	DIN Data input	0x0	R	Data input

24.6.16 GPIO_PORTD_CTRL - Port Control

Offset	Bit Position																																	
0x0C0	31	30	29	28	27	26	25	24	23	22	21	20	19	18	17	16	15	14	13	12	11	10	9	8	7	6	5	4	3	2	1	0		
Reset				0x0								0x4												0x0							0x4			
Access				RW								RW												RW							RW			
Name				DINDISALT								SLEWRATEALT												DINDIS							SLEWRATE			

Bit	Name	Reset	Access	Description
31:29	Reserved			To ensure compatibility with future devices, always write Reserved bits to their reset value, unless otherwise stated. More information in 1.2 Conventions
28	DINDISALT	0x0	RW	Data In Disable Alt Data input disable for port pins using alternate modes.
27:23	Reserved			To ensure compatibility with future devices, always write Reserved bits to their reset value, unless otherwise stated. More information in 1.2 Conventions
22:20	SLEWRATEALT	0x4	RW	Slew Rate Alt Slewrates limit for port pins using alternate modes. Higher values represent faster slewrates.
19:13	Reserved			To ensure compatibility with future devices, always write Reserved bits to their reset value, unless otherwise stated. More information in 1.2 Conventions
12	DINDIS	0x0	RW	Data In Disable Data input disable for port pins not using alternate modes.
11:7	Reserved			To ensure compatibility with future devices, always write Reserved bits to their reset value, unless otherwise stated. More information in 1.2 Conventions
6:4	SLEWRATE	0x4	RW	Slew Rate Slewrates limit for port pins using not alternate modes. Higher values represent faster slewrates.
3:0	Reserved			To ensure compatibility with future devices, always write Reserved bits to their reset value, unless otherwise stated. More information in 1.2 Conventions

24.6.17 GPIO_PORTD_MODEL - Mode Low

Offset	Bit Position																															
0x0C4	31	30	29	28	27	26	25	24	23	22	21	20	19	18	17	16	15	14	13	12	11	10	9	8	7	6	5	4	3	2	1	0
Reset									0x0				0x0				0x0				0x0				0x0							
Access									RW				RW				RW				RW				RW							
Name									MODE5				MODE4				MODE3				MODE2				MODE1				MODE0			

Bit	Name	Reset	Access	Description
31:24	<i>Reserved</i>	<i>To ensure compatibility with future devices, always write Reserved bits to their reset value, unless otherwise stated. More information in 1.2 Conventions</i>		
23:20	MODE5 MODE n	0x0	RW	MODE n
	Value	Mode		Description
	0	DISABLED		Input disabled. Pullup if DOUT is set.
	1	INPUT		Input enabled. Filter if DOUT is set.
	2	INPUTPULL		Input enabled. DOUT determines pull direction.
	3	INPUTPULLFILTER		Input enabled with filter. DOUT determines pull direction.
	4	PUSHPULL		Push-pull output.
	5	PUSHPULLALT		Push-pull using alternate control.
	6	WIREDOR		Wired-or output.
	7	WIREDORPULLDOWN		Wired-or output with pull-down.
	8	WIREDAND		Open-drain output.
	9	WIREDANDFILTER		Open-drain output with filter.
	10	WIREDANDPULLUP		Open-drain output with pullup.
	11	WIREDANDPULLUPFILTER		Open-drain output with filter and pullup.
	12	WIREDANDALT		Open-drain output using alternate control.
	13	WIREDANDALTFILTER		Open-drain output using alternate control with filter.
	14	WIREDANDALTPULLUP		Open-drain output using alternate control with pullup.
	15	WIREDANDALTPULLUPFILTER		Open-drain output using alternate control with filter and pullup.
19:16	MODE4 MODE n	0x0	RW	MODE n
	Value	Mode		Description
	0	DISABLED		Input disabled. Pullup if DOUT is set.
	1	INPUT		Input enabled. Filter if DOUT is set.
	2	INPUTPULL		Input enabled. DOUT determines pull direction.

Bit	Name	Reset	Access	Description
	3	INPUTPULLFILTER		Input enabled with filter. DOUT determines pull direction.
	4	PUSHPULL		Push-pull output.
	5	PUSHPULLALT		Push-pull using alternate control.
	6	WIREDOR		Wired-or output.
	7	WIREDORPULLDOWN		Wired-or output with pull-down.
	8	WIREDAND		Open-drain output.
	9	WIREDANDFILTER		Open-drain output with filter.
	10	WIREDANDPULLUP		Open-drain output with pullup.
	11	WIREDANDPULLUPFILTER		Open-drain output with filter and pullup.
	12	WIREDANDALT		Open-drain output using alternate control.
	13	WIREDANDALTFILTER		Open-drain output using alternate control with filter.
	14	WIREDANDALTPULLUP		Open-drain output using alternate control with pullup.
	15	WIREDANDALTPULLUPFILTER		Open-drain output using alternate control with filter and pullup.
15:12	MODE3 MODE n	0x0	RW	MODE n
	Value	Mode		Description
	0	DISABLED		Input disabled. Pullup if DOUT is set.
	1	INPUT		Input enabled. Filter if DOUT is set.
	2	INPUTPULL		Input enabled. DOUT determines pull direction.
	3	INPUTPULLFILTER		Input enabled with filter. DOUT determines pull direction.
	4	PUSHPULL		Push-pull output.
	5	PUSHPULLALT		Push-pull using alternate control.
	6	WIREDOR		Wired-or output.
	7	WIREDORPULLDOWN		Wired-or output with pull-down.
	8	WIREDAND		Open-drain output.
	9	WIREDANDFILTER		Open-drain output with filter.
	10	WIREDANDPULLUP		Open-drain output with pullup.
	11	WIREDANDPULLUPFILTER		Open-drain output with filter and pullup.
	12	WIREDANDALT		Open-drain output using alternate control.
	13	WIREDANDALTFILTER		Open-drain output using alternate control with filter.
	14	WIREDANDALTPULLUP		Open-drain output using alternate control with pullup.
	15	WIREDANDALTPULLUPFILTER		Open-drain output using alternate control with filter and pullup.
11:8	MODE2 MODE n	0x0	RW	MODE n

Bit	Name	Reset	Access	Description
	Value	Mode		Description
	0	DISABLED		Input disabled. Pullup if DOUT is set.
	1	INPUT		Input enabled. Filter if DOUT is set.
	2	INPUTPULL		Input enabled. DOUT determines pull direction.
	3	INPUTPULLFILTER		Input enabled with filter. DOUT determines pull direction.
	4	PUSHPULL		Push-pull output.
	5	PUSHPULLALT		Push-pull using alternate control.
	6	WIREDOR		Wired-or output.
	7	WIREDORPULLDOWN		Wired-or output with pull-down.
	8	WIREDAND		Open-drain output.
	9	WIREDANDFILTER		Open-drain output with filter.
	10	WIREDANDPULLUP		Open-drain output with pullup.
	11	WIREDANDPULLUPFILTER		Open-drain output with filter and pullup.
	12	WIREDANDALT		Open-drain output using alternate control.
	13	WIREDANDALTFILTER		Open-drain output using alternate control with filter.
	14	WIREDANDALTPULLUP		Open-drain output using alternate control with pullup.
	15	WIREDANDALTPULLUPFILTER		Open-drain output using alternate control with filter and pullup.
7:4	MODE1 MODE n	0x0	RW	MODE n
	Value	Mode		Description
	0	DISABLED		Input disabled. Pullup if DOUT is set.
	1	INPUT		Input enabled. Filter if DOUT is set.
	2	INPUTPULL		Input enabled. DOUT determines pull direction.
	3	INPUTPULLFILTER		Input enabled with filter. DOUT determines pull direction.
	4	PUSHPULL		Push-pull output.
	5	PUSHPULLALT		Push-pull using alternate control.
	6	WIREDOR		Wired-or output.
	7	WIREDORPULLDOWN		Wired-or output with pull-down.
	8	WIREDAND		Open-drain output.
	9	WIREDANDFILTER		Open-drain output with filter.
	10	WIREDANDPULLUP		Open-drain output with pullup.
	11	WIREDANDPULLUPFILTER		Open-drain output with filter and pullup.
	12	WIREDANDALT		Open-drain output using alternate control.
	13	WIREDANDALTFILTER		Open-drain output using alternate control with filter.

Bit	Name	Reset	Access	Description
	14	WIREDANDALTPULLUP		Open-drain output using alternate control with pullup.
	15	WIREDANDALTPULLUP-FILTER		Open-drain output using alternate control with filter and pullup.
3:0	MODE0 MODE n	0x0	RW	MODE n
	Value	Mode		Description
	0	DISABLED		Input disabled. Pullup if DOUT is set.
	1	INPUT		Input enabled. Filter if DOUT is set.
	2	INPUTPULL		Input enabled. DOUT determines pull direction.
	3	INPUTPULLFILTER		Input enabled with filter. DOUT determines pull direction.
	4	PUSHPULL		Push-pull output.
	5	PUSHPULLALT		Push-pull using alternate control.
	6	WIREDOR		Wired-or output.
	7	WIREDORPULLDOWN		Wired-or output with pull-down.
	8	WIREDAND		Open-drain output.
	9	WIREDANDFILTER		Open-drain output with filter.
	10	WIREDANDPULLUP		Open-drain output with pullup.
	11	WIREDANDPULLUPFILTER		Open-drain output with filter and pullup.
	12	WIREDANDALT		Open-drain output using alternate control.
	13	WIREDANDALTFILTER		Open-drain output using alternate control with filter.
	14	WIREDANDALTPULLUP		Open-drain output using alternate control with pullup.
	15	WIREDANDALTPULLUP-FILTER		Open-drain output using alternate control with filter and pullup.

24.6.18 GPIO_PORTD_DOUT - Data Out

Offset	Bit Position																															
0x0D0	31	30	29	28	27	26	25	24	23	22	21	20	19	18	17	16	15	14	13	12	11	10	9	8	7	6	5	4	3	2	1	0
Reset																											0x0					
Access																											RW					
Name																											DOUT					

Bit	Name	Reset	Access	Description
31:6	<i>Reserved</i>	<i>To ensure compatibility with future devices, always write Reserved bits to their reset value, unless otherwise stated. More information in 1.2 Conventions</i>		
5:0	DOUT Data output	0x0	RW	Data output

24.6.19 GPIO_PORTD_DIN - Data in

Offset	Bit Position																															
0x0D4	31	30	29	28	27	26	25	24	23	22	21	20	19	18	17	16	15	14	13	12	11	10	9	8	7	6	5	4	3	2	1	0
Reset																													0x0			
Access																													R			
Name																													DIN			

Bit	Name	Reset	Access	Description
31:6	Reserved	To ensure compatibility with future devices, always write Reserved bits to their reset value, unless otherwise stated. More information in 1.2 Conventions		
5:0	DIN Data input	0x0	R	Data input

24.6.20 GPIO_LOCK - Lock Register

Offset	Bit Position																															
0x300	31	30	29	28	27	26	25	24	23	22	21	20	19	18	17	16	15	14	13	12	11	10	9	8	7	6	5	4	3	2	1	0
Reset																													0xA534			
Access																													W			
Name																													LOCKKEY			

Bit	Name	Reset	Access	Description
31:16	Reserved	To ensure compatibility with future devices, always write Reserved bits to their reset value, unless otherwise stated. More information in 1.2 Conventions		
15:0	LOCKKEY	0xA534	W	Configuration Lock Key Write any other value than the unlock code to lock configuration registers. Write the unlock code to unlock (See text for detailed list of configuration registers.)
	Value	Mode	Description	
	42292	UNLOCK	Unlock code	

24.6.21 GPIO_GPIOLockSTATUS - Lock Status

Offset	Bit Position																															
0x310	31	30	29	28	27	26	25	24	23	22	21	20	19	18	17	16	15	14	13	12	11	10	9	8	7	6	5	4	3	2	1	0
Reset																																0x0
Access																																R
Name																																LOCK

Bit	Name	Reset	Access	Description
31:1	<i>Reserved</i>	<i>To ensure compatibility with future devices, always write Reserved bits to their reset value, unless otherwise stated. More information in 1.2 Conventions</i>		
0	LOCK	0x0	R	GPIO LOCK status Indicates current lock status of GPIO registers
	Value	Mode		Description
	0	UNLOCKED		Registers are unlocked
	1	LOCKED		Registers are locked

24.6.22 GPIO_ABUSALLOC - A Bus Allocation

Offset	Bit Position																																	
0x320	31	30	29	28	27	26	25	24	23	22	21	20	19	18	17	16	15	14	13	12	11	10	9	8	7	6	5	4	3	2	1	0		
Reset						0x0										0x0										0x0								
Access						RW										RW										RW								
Name						AODD1										AODD0										AEVEN1							AEVEN0	

Bit	Name	Reset	Access	Description
31:28	<i>Reserved</i>	<i>To ensure compatibility with future devices, always write Reserved bits to their reset value, unless otherwise stated. More information in 1.2 Conventions</i>		
27:24	AODD1	0x0	RW	A Bus Odd 1 peripheral allocation to A Bus Odd 1
	Value	Mode	Description	
	0	TRISTATE	The bus is not allocated	
	1	ADC0	The bus is allocated to ADC0	
	2	ACMP0	The bus is allocated to ACMP0	
	3	ACMP1	The bus is allocated to ACMP1	
	4	VDAC0CH1	The bus is allocated to VDAC0 CH1	
	5	VDAC1CH1	The bus is allocated to VDAC1 CH1	
23:20	<i>Reserved</i>	<i>To ensure compatibility with future devices, always write Reserved bits to their reset value, unless otherwise stated. More information in 1.2 Conventions</i>		
19:16	AODD0	0x0	RW	A Bus Odd 0 peripheral allocation to A Bus Odd 0
	Value	Mode	Description	
	0	TRISTATE	The bus is not allocated	
	1	ADC0	The bus is allocated to ADC0	
	2	ACMP0	The bus is allocated to ACMP0	
	3	ACMP1	The bus is allocated to ACMP1	
	4	VDAC0CH0	The bus is allocated to VDAC0 CH0	
	5	VDAC1CH0	The bus is allocated to VDAC1 CH0	
15:12	<i>Reserved</i>	<i>To ensure compatibility with future devices, always write Reserved bits to their reset value, unless otherwise stated. More information in 1.2 Conventions</i>		
11:8	AEVEN1	0x0	RW	A Bus Even 1 peripheral allocation to A Bus Even 1
	Value	Mode	Description	
	0	TRISTATE	The bus is not allocated	

Bit	Name	Reset	Access	Description
1		ADC0		The bus is allocated to ADC0
2		ACMP0		The bus is allocated to ACMP0
3		ACMP1		The bus is allocated to ACMP1
4		VDAC0CH1		The bus is allocated to VDAC0 CH1
5		VDAC1CH1		The bus is allocated to VDAC1 CH1
7:4	<i>Reserved</i>	<i>To ensure compatibility with future devices, always write Reserved bits to their reset value, unless otherwise stated. More information in 1.2 Conventions</i>		
3:0	AEVEN0	0x0	RW	A Bus Even 0
	peripheral allocation to A Bus Even 0			
	Value	Mode	Description	
	0	TRISTATE	The bus is not allocated	
	1	ADC0	The bus is allocated to ADC0	
	2	ACMP0	The bus is allocated to ACMP0	
	3	ACMP1	The bus is allocated to ACMP1	
	4	VDAC0CH0	The bus is allocated to VDAC0 CH0	
	5	VDAC1CH0	The bus is allocated to VDAC1 CH0	

24.6.23 GPIO_BBUSALLOC - B Bus Allocation

Offset	Bit Position																															
0x324	31	30	29	28	27	26	25	24	23	22	21	20	19	18	17	16	15	14	13	12	11	10	9	8	7	6	5	4	3	2	1	0
Reset						0x0										0x0										0x0						
Access						RW										RW										RW						
Name						BODD1										BODD0										BEVEN1				BEVEN0		

Bit	Name	Reset	Access	Description
31:28	<i>Reserved</i>	<i>To ensure compatibility with future devices, always write Reserved bits to their reset value, unless otherwise stated. More information in 1.2 Conventions</i>		
27:24	BODD1	0x0	RW	B Bus Odd 1 peripheral allocation to B Bus Odd 1
	Value	Mode	Description	
	0	TRISTATE	The bus is not allocated	
	1	ADC0	The bus is allocated to ADC0	
	2	ACMP0	The bus is allocated to ACMP0	
	3	ACMP1	The bus is allocated to ACMP1	
	4	VDAC0CH1	The bus is allocated to VDAC0 CH1	
	5	VDAC1CH1	The bus is allocated to VDAC1 CH1	
23:20	<i>Reserved</i>	<i>To ensure compatibility with future devices, always write Reserved bits to their reset value, unless otherwise stated. More information in 1.2 Conventions</i>		
19:16	BODD0	0x0	RW	B Bus Odd 0 peripheral allocation to B Bus Odd 0
	Value	Mode	Description	
	0	TRISTATE	The bus is not allocated	
	1	ADC0	The bus is allocated to ADC0	
	2	ACMP0	The bus is allocated to ACMP0	
	3	ACMP1	The bus is allocated to ACMP1	
	4	VDAC0CH0	The bus is allocated to VDAC0 CH0	
	5	VDAC1CH0	The bus is allocated to VDAC1 CH0	
15:12	<i>Reserved</i>	<i>To ensure compatibility with future devices, always write Reserved bits to their reset value, unless otherwise stated. More information in 1.2 Conventions</i>		
11:8	BEVEN1	0x0	RW	B Bus Even 1 peripheral allocation to B Bus Even 1
	Value	Mode	Description	
	0	TRISTATE	The bus is not allocated	

Bit	Name	Reset	Access	Description
1		ADC0		The bus is allocated to ADC0
2		ACMP0		The bus is allocated to ACMP0
3		ACMP1		The bus is allocated to ACMP1
4		VDAC0CH1		The bus is allocated to VDAC0 CH1
5		VDAC1CH1		The bus is allocated to VDAC1 CH1
7:4	<i>Reserved</i>	<i>To ensure compatibility with future devices, always write Reserved bits to their reset value, unless otherwise stated. More information in 1.2 Conventions</i>		
3:0	BEVEN0	0x0	RW	B Bus Even 0
	peripheral allocation to B Bus Even 0			
	Value	Mode	Description	
	0	TRISTATE	The bus is not allocated	
	1	ADC0	The bus is allocated to ADC0	
	2	ACMP0	The bus is allocated to ACMP0	
	3	ACMP1	The bus is allocated to ACMP1	
	4	VDAC0CH0	The bus is allocated to VDAC0 CH0	
	5	VDAC1CH0	The bus is allocated to VDAC1 CH0	

24.6.24 GPIO_CDBUSALLOC - CD Bus Allocation

Offset	Bit Position																															
0x328	31	30	29	28	27	26	25	24	23	22	21	20	19	18	17	16	15	14	13	12	11	10	9	8	7	6	5	4	3	2	1	0
Reset						0x0										0x0										0x0						
Access						RW										RW										RW						
Name						CDODD1										CDODD0										CDEVEN1				CDEVEN0		

Bit	Name	Reset	Access	Description
31:28	<i>Reserved</i>	<i>To ensure compatibility with future devices, always write Reserved bits to their reset value, unless otherwise stated. More information in 1.2 Conventions</i>		
27:24	CDODD1	0x0	RW	CD Bus Odd 1 peripheral allocation to CD Bus Odd 1
	Value	Mode		Description
	0	TRISTATE		The bus is not allocated
	1	ADC0		The bus is allocated to ADC0
	2	ACMP0		The bus is allocated to ACMP0
	3	ACMP1		The bus is allocated to ACMP1
	4	VDAC0CH1		The bus is allocated to VDAC0 CH1
	5	VDAC1CH1		The bus is allocated to VDAC1 CH1
23:20	<i>Reserved</i>	<i>To ensure compatibility with future devices, always write Reserved bits to their reset value, unless otherwise stated. More information in 1.2 Conventions</i>		
19:16	CDODD0	0x0	RW	CD Bus Odd 0 peripheral allocation to CD Bus Odd 0
	Value	Mode		Description
	0	TRISTATE		The bus is not allocated
	1	ADC0		The bus is allocated to ADC0
	2	ACMP0		The bus is allocated to ACMP0
	3	ACMP1		The bus is allocated to ACMP1
	4	VDAC0CH0		The bus is allocated to VDAC0 CH0
	5	VDAC1CH0		The bus is allocated to VDAC1 CH0
15:12	<i>Reserved</i>	<i>To ensure compatibility with future devices, always write Reserved bits to their reset value, unless otherwise stated. More information in 1.2 Conventions</i>		
11:8	CDEVEN1	0x0	RW	CD Bus Even 1 peripheral allocation to CD Bus Even 1
	Value	Mode		Description
	0	TRISTATE		The bus is not allocated

Bit	Name	Reset	Access	Description
1		ADC0		The bus is allocated to ADC0
2		ACMP0		The bus is allocated to ACMP0
3		ACMP1		The bus is allocated to ACMP1
4		VDAC0CH1		The bus is allocated to VDAC0 CH1
5		VDAC1CH1		The bus is allocated to VDAC1 CH1
7:4	<i>Reserved</i>	<i>To ensure compatibility with future devices, always write Reserved bits to their reset value, unless otherwise stated. More information in 1.2 Conventions</i>		
3:0	CDEVEN0	0x0	RW	CD Bus Even 0
	peripheral allocation to CD Bus Even 0			
	Value	Mode	Description	
	0	TRISTATE	The bus is not allocated	
	1	ADC0	The bus is allocated to ADC0	
	2	ACMP0	The bus is allocated to ACMP0	
	3	ACMP1	The bus is allocated to ACMP1	
	4	VDAC0CH0	The bus is allocated to VDAC0 CH0	
	5	VDAC1CH0	The bus is allocated to VDAC1 CH0	

24.6.25 GPIO_EXTIPSELL - External Interrupt Port Select Low

Offset	Bit Position																															
0x400	31	30	29	28	27	26	25	24	23	22	21	20	19	18	17	16	15	14	13	12	11	10	9	8	7	6	5	4	3	2	1	0
Reset			0x0				0x0				0x0				0x0				0x0				0x0				0x0					0x0
Access			RW				RW				RW				RW				RW				RW				RW					RW
Name			EXTIPSEL7				EXTIPSEL6				EXTIPSEL5				EXTIPSEL4				EXTIPSEL3				EXTIPSEL2				EXTIPSEL1					EXTIPSEL0

Bit	Name	Reset	Access	Description
31:30	Reserved	To ensure compatibility with future devices, always write Reserved bits to their reset value, unless otherwise stated. More information in 1.2 Conventions		
29:28	EXTIPSEL7	0x0	RW	External Interrupt Port Select Port select for external interrupt 7 (EXTI7)
	Value	Mode	Description	
	0	PORTA	Port A group selected	
	1	PORTB	Port B group selected	
	2	PORTC	Port C group selected	
	3	PORTD	Port D group selected	
27:26	Reserved	To ensure compatibility with future devices, always write Reserved bits to their reset value, unless otherwise stated. More information in 1.2 Conventions		
25:24	EXTIPSEL6	0x0	RW	External Interrupt Port Select Port select for external interrupt 6 (EXTI6)
	Value	Mode	Description	
	0	PORTA	Port A group selected	
	1	PORTB	Port B group selected	
	2	PORTC	Port C group selected	
	3	PORTD	Port D group selected	
23:22	Reserved	To ensure compatibility with future devices, always write Reserved bits to their reset value, unless otherwise stated. More information in 1.2 Conventions		
21:20	EXTIPSEL5	0x0	RW	External Interrupt Port Select Port select for external interrupt 5 (EXTI5)
	Value	Mode	Description	
	0	PORTA	Port A group selected	
	1	PORTB	Port B group selected	
	2	PORTC	Port C group selected	
	3	PORTD	Port D group selected	

Bit	Name	Reset	Access	Description
19:18	<i>Reserved</i>	<i>To ensure compatibility with future devices, always write Reserved bits to their reset value, unless otherwise stated. More information in 1.2 Conventions</i>		
17:16	EXTIPSEL4	0x0	RW	External Interrupt Port Select Port select for external interrupt 4 (EXTI4)
	Value	Mode	Description	
	0	PORTA	Port A group selected	
	1	PORTB	Port B group selected	
	2	PORTC	Port C group selected	
	3	PORTD	Port D group selected	
15:14	<i>Reserved</i>	<i>To ensure compatibility with future devices, always write Reserved bits to their reset value, unless otherwise stated. More information in 1.2 Conventions</i>		
13:12	EXTIPSEL3	0x0	RW	External Interrupt Port Select Port select for external interrupt 3 (EXTI3)
	Value	Mode	Description	
	0	PORTA	Port A group selected	
	1	PORTB	Port B group selected	
	2	PORTC	Port C group selected	
	3	PORTD	Port D group selected	
11:10	<i>Reserved</i>	<i>To ensure compatibility with future devices, always write Reserved bits to their reset value, unless otherwise stated. More information in 1.2 Conventions</i>		
9:8	EXTIPSEL2	0x0	RW	External Interrupt Port Select Port select for external interrupt 2 (EXTI2)
	Value	Mode	Description	
	0	PORTA	Port A group selected	
	1	PORTB	Port B group selected	
	2	PORTC	Port C group selected	
	3	PORTD	Port D group selected	
7:6	<i>Reserved</i>	<i>To ensure compatibility with future devices, always write Reserved bits to their reset value, unless otherwise stated. More information in 1.2 Conventions</i>		
5:4	EXTIPSEL1	0x0	RW	External Interrupt Port Select Port select for external interrupt 1 (EXTI1)
	Value	Mode	Description	
	0	PORTA	Port A group selected	
	1	PORTB	Port B group selected	
	2	PORTC	Port C group selected	
	3	PORTD	Port D group selected	

Bit	Name	Reset	Access	Description
3:2	<i>Reserved</i>	<i>To ensure compatibility with future devices, always write Reserved bits to their reset value, unless otherwise stated. More information in 1.2 Conventions</i>		
1:0	EXTIPSEL0	0x0	RW	External Interrupt Port Select Port select for external interrupt 0 (EXTI0)
	Value	Mode	Description	
	0	PORTA	Port A group selected	
	1	PORTB	Port B group selected	
	2	PORTC	Port C group selected	
	3	PORTD	Port D group selected	

24.6.26 GPIO_EXTIPSELH - External Interrupt Port Select High

Offset	Bit Position																																										
0x404	31	30	29	28	27	26	25	24	23	22	21	20	19	18	17	16	15	14	13	12	11	10	9	8	7	6	5	4	3	2	1	0											
Reset																	0x0			0x0			0x0			0x0								0x0									
Access																	RW			RW			RW			RW													RW				
Name																	EXTIPSEL3			EXTIPSEL2			EXTIPSEL1																				EXTIPSELO

Bit	Name	Reset	Access	Description
31:14	<i>Reserved</i>	<i>To ensure compatibility with future devices, always write Reserved bits to their reset value, unless otherwise stated. More information in 1.2 Conventions</i>		
13:12	EXTIPSEL3	0x0	RW	External Interrupt Port Select Port select for external interrupt 3+8
	Value	Mode	Description	
	0	PORTA	Port A group selected	
	1	PORTB	Port B group selected	
	2	PORTC	Port C group selected	
	3	PORTD	Port D group selected	
11:10	<i>Reserved</i>	<i>To ensure compatibility with future devices, always write Reserved bits to their reset value, unless otherwise stated. More information in 1.2 Conventions</i>		
9:8	EXTIPSEL2	0x0	RW	External Interrupt Port Select Port select for external interrupt 2+8
	Value	Mode	Description	
	0	PORTA	Port A group selected	
	1	PORTB	Port B group selected	
	2	PORTC	Port C group selected	
	3	PORTD	Port D group selected	
7:6	<i>Reserved</i>	<i>To ensure compatibility with future devices, always write Reserved bits to their reset value, unless otherwise stated. More information in 1.2 Conventions</i>		
5:4	EXTIPSEL1	0x0	RW	External Interrupt Port Select Port select for external interrupt 1+8
	Value	Mode	Description	
	0	PORTA	Port A group selected	
	1	PORTB	Port B group selected	
	2	PORTC	Port C group selected	
	3	PORTD	Port D group selected	

Bit	Name	Reset	Access	Description
3:2	<i>Reserved</i>	<i>To ensure compatibility with future devices, always write Reserved bits to their reset value, unless otherwise stated. More information in 1.2 Conventions</i>		
1:0	EXTIPSEL0	0x0	RW	External Interrupt Port Select Port select for external interrupt 0+8
	Value	Mode	Description	
	0	PORTA	Port A group selected	
	1	PORTB	Port B group selected	
	2	PORTC	Port C group selected	
	3	PORTD	Port D group selected	

24.6.27 GPIO_EXTIPINSELL - External Interrupt Pin Select Low

Offset	Bit Position																																
0x408	31	30	29	28	27	26	25	24	23	22	21	20	19	18	17	16	15	14	13	12	11	10	9	8	7	6	5	4	3	2	1	0	
Reset			0x0				0x0				0x0				0x0					0x0				0x0				0x0					0x0
Access			RW				RW				RW				RW					RW				RW				RW					RW
Name			EXTIPINSEL7				EXTIPINSEL6				EXTIPINSEL5				EXTIPINSEL4					EXTIPINSEL3				EXTIPINSEL2				EXTIPINSEL1					EXTIPINSEL0

Bit	Name	Reset	Access	Description
31:30	<i>Reserved</i>	<i>To ensure compatibility with future devices, always write Reserved bits to their reset value, unless otherwise stated. More information in 1.2 Conventions</i>		
29:28	EXTIPINSEL7	0x0	RW	External Interrupt Pin select OFFSET select for External Interrupt 7 (EXTI7)
	Value	Mode	Description	
	0	PIN0	OFFSET=0	
	1	PIN1	OFFSET=1	
	2	PIN2	OFFSET=2	
	3	PIN3	OFFSET=3	
27:26	<i>Reserved</i>	<i>To ensure compatibility with future devices, always write Reserved bits to their reset value, unless otherwise stated. More information in 1.2 Conventions</i>		
25:24	EXTIPINSEL6	0x0	RW	External Interrupt Pin select OFFSET select for External Interrupt 6 (EXTI6)
	Value	Mode	Description	
	0	PIN0	OFFSET=0	
	1	PIN1	OFFSET=1	
	2	PIN2	OFFSET=2	
	3	PIN3	OFFSET=3	
23:22	<i>Reserved</i>	<i>To ensure compatibility with future devices, always write Reserved bits to their reset value, unless otherwise stated. More information in 1.2 Conventions</i>		
21:20	EXTIPINSEL5	0x0	RW	External Interrupt Pin select OFFSET select for External Interrupt 5 (EXTI5)
	Value	Mode	Description	
	0	PIN0	OFFSET=0	
	1	PIN1	OFFSET=1	
	2	PIN2	OFFSET=2	
	3	PIN3	OFFSET=3	

Bit	Name	Reset	Access	Description
19:18	<i>Reserved</i>	<i>To ensure compatibility with future devices, always write Reserved bits to their reset value, unless otherwise stated. More information in 1.2 Conventions</i>		
17:16	EXTIPINSEL4	0x0	RW	External Interrupt Pin select OFFSET select for External Interrupt 4 (EXTI4)
	Value	Mode	Description	
	0	PIN0	OFFSET=0	
	1	PIN1	OFFSET=1	
	2	PIN2	OFFSET=2	
	3	PIN3	OFFSET=3	
15:14	<i>Reserved</i>	<i>To ensure compatibility with future devices, always write Reserved bits to their reset value, unless otherwise stated. More information in 1.2 Conventions</i>		
13:12	EXTIPINSEL3	0x0	RW	External Interrupt Pin select OFFSET select for External Interrupt 3 (EXTI3)
	Value	Mode	Description	
	0	PIN0	OFFSET=0	
	1	PIN1	OFFSET=1	
	2	PIN2	OFFSET=2	
	3	PIN3	OFFSET=3	
11:10	<i>Reserved</i>	<i>To ensure compatibility with future devices, always write Reserved bits to their reset value, unless otherwise stated. More information in 1.2 Conventions</i>		
9:8	EXTIPINSEL2	0x0	RW	External Interrupt Pin select OFFSET select for External Interrupt 2 (EXTI2)
	Value	Mode	Description	
	0	PIN0	OFFSET=0	
	1	PIN1	OFFSET=1	
	2	PIN2	OFFSET=2	
	3	PIN3	OFFSET=3	
7:6	<i>Reserved</i>	<i>To ensure compatibility with future devices, always write Reserved bits to their reset value, unless otherwise stated. More information in 1.2 Conventions</i>		
5:4	EXTIPINSEL1	0x0	RW	External Interrupt Pin select OFFSET select for External Interrupt 1 (EXTI1)
	Value	Mode	Description	
	0	PIN0	OFFSET=0	
	1	PIN1	OFFSET=1	
	2	PIN2	OFFSET=2	
	3	PIN3	OFFSET=3	

Bit	Name	Reset	Access	Description
3:2	<i>Reserved</i>	<i>To ensure compatibility with future devices, always write Reserved bits to their reset value, unless otherwise stated. More information in 1.2 Conventions</i>		
1:0	EXTIPINSEL0	0x0	RW	External Interrupt Pin select OFFSET select for External Interrupt 0 (EXTI0)
	Value	Mode	Description	
	0	PIN0	OFFSET=0	
	1	PIN1	OFFSET=1	
	2	PIN2	OFFSET=2	
	3	PIN3	OFFSET=3	

24.6.28 GPIO_EXTIPINSELH - External Interrupt Pin Select High

Offset	Bit Position																																										
0x40C	31	30	29	28	27	26	25	24	23	22	21	20	19	18	17	16	15	14	13	12	11	10	9	8	7	6	5	4	3	2	1	0											
Reset																	0x0			0x0			0x0			0x0								0x0									
Access																	RW			RW			RW			RW															RW		
Name																	EXTIPINSEL3			EXTIPINSEL2			EXTIPINSEL1																				EXTIPINSELO

Bit	Name	Reset	Access	Description
31:14	<i>Reserved</i>	<i>To ensure compatibility with future devices, always write Reserved bits to their reset value, unless otherwise stated. More information in 1.2 Conventions</i>		
13:12	EXTIPINSEL3	0x0	RW	External Interrupt Pin select OFFSET select for External Interrupt {b+8} (EXTI{b+8})
	Value	Mode		Description
	0	PIN8		OFFSET=8
	1	PIN9		OFFSET=9
	2	PIN10		OFFSET=10
	3	PIN11		OFFSET=11
11:10	<i>Reserved</i>	<i>To ensure compatibility with future devices, always write Reserved bits to their reset value, unless otherwise stated. More information in 1.2 Conventions</i>		
9:8	EXTIPINSEL2	0x0	RW	External Interrupt Pin select OFFSET select for External Interrupt {b+8} (EXTI{b+8})
	Value	Mode		Description
	0	PIN8		OFFSET=8
	1	PIN9		OFFSET=9
	2	PIN10		OFFSET=10
	3	PIN11		OFFSET=11
7:6	<i>Reserved</i>	<i>To ensure compatibility with future devices, always write Reserved bits to their reset value, unless otherwise stated. More information in 1.2 Conventions</i>		
5:4	EXTIPINSEL1	0x0	RW	External Interrupt Pin select OFFSET select for External Interrupt {b+8} (EXTI{b+8})
	Value	Mode		Description
	0	PIN8		OFFSET=8
	1	PIN9		OFFSET=9
	2	PIN10		OFFSET=10
	3	PIN11		OFFSET=11

Bit	Name	Reset	Access	Description
3:2	<i>Reserved</i>	<i>To ensure compatibility with future devices, always write Reserved bits to their reset value, unless otherwise stated. More information in 1.2 Conventions</i>		
1:0	EXTIPINSEL0	0x0	RW	External Interrupt Pin select OFFSET select for External Interrupt {b+8} (EXTI{b+8})
	Value	Mode	Description	
	0	PIN8	OFFSET=8	
	1	PIN9	OFFSET=9	
	2	PIN10	OFFSET=10	
	3	PIN11	OFFSET=11	

24.6.29 GPIO_EXTIRISE - External Interrupt Rising Edge Trigger

Offset	Bit Position																															
0x410	31	30	29	28	27	26	25	24	23	22	21	20	19	18	17	16	15	14	13	12	11	10	9	8	7	6	5	4	3	2	1	0
Reset												0x0																				
Access												RW																				
Name												EXTIRISE																				

Bit	Name	Reset	Access	Description
31:12	<i>Reserved</i>	<i>To ensure compatibility with future devices, always write Reserved bits to their reset value, unless otherwise stated. More information in 1.2 Conventions</i>		
11:0	EXTIRISE	0x0	RW	EXT Int Rise External Interrupt n Rising Edge Trigger Enable

24.6.30 GPIO_EXTIFALL - External Interrupt Falling Edge Trigger

Offset	Bit Position																															
0x414	31	30	29	28	27	26	25	24	23	22	21	20	19	18	17	16	15	14	13	12	11	10	9	8	7	6	5	4	3	2	1	0
Reset																							0x0									
Access																							RW									
Name																							EXTIFALL									

Bit	Name	Reset	Access	Description
31:12	<i>Reserved</i>	<i>To ensure compatibility with future devices, always write Reserved bits to their reset value, unless otherwise stated. More information in 1.2 Conventions</i>		
11:0	EXTIFALL External Interrupt n Falling Edge Trigger Enable	0x0	RW	EXT Int FALL

24.6.31 GPIO_IF - Interrupt Flag

Offset	Bit Position																																													
0x420	31	30	29	28	27	26	25	24	23	22	21	20	19	18	17	16	15	14	13	12	11	10	9	8	7	6	5	4	3	2	1	0														
Reset												0x0																	0x0	0x0	0x0	0x0	0x0	0x0	0x0	0x0	0x0	0x0	0x0	0x0						
Access												RW																	RW	RW	RW	RW	RW	RW	RW	RW	RW	RW	RW	RW	RW	RW	RW	RW	RW	RW
Name												EM4WU																	EXTIF11	EXTIF10	EXTIF9	EXTIF8	EXTIF7	EXTIF6	EXTIF5	EXTIF4	EXTIF3	EXTIF2	EXTIF1	EXTIF0						

Bit	Name	Reset	Access	Description
31:28	<i>Reserved</i>	<i>To ensure compatibility with future devices, always write Reserved bits to their reset value, unless otherwise stated. More information in 1.2 Conventions</i>		
27:16	EM4WU	0x0	RW	EM4 wake up
15:12	<i>Reserved</i>	<i>To ensure compatibility with future devices, always write Reserved bits to their reset value, unless otherwise stated. More information in 1.2 Conventions</i>		
11	EXTIF11 External Pin interrupt flag	0x0	RW	External Pin Flag
10	EXTIF10 External Pin interrupt flag	0x0	RW	External Pin Flag
9	EXTIF9 External Pin interrupt flag	0x0	RW	External Pin Flag
8	EXTIF8 External Pin interrupt flag	0x0	RW	External Pin Flag
7	EXTIF7 External Pin interrupt flag	0x0	RW	External Pin Flag
6	EXTIF6 External Pin interrupt flag	0x0	RW	External Pin Flag
5	EXTIF5 External Pin interrupt flag	0x0	RW	External Pin Flag
4	EXTIF4 External Pin interrupt flag	0x0	RW	External Pin Flag
3	EXTIF3 External Pin interrupt flag	0x0	RW	External Pin Flag
2	EXTIF2 External Pin interrupt flag	0x0	RW	External Pin Flag
1	EXTIF1 External Pin interrupt flag	0x0	RW	External Pin Flag
0	EXTIF0	0x0	RW	External Pin Flag

Bit	Name	Reset	Access	Description
	External Pin interrupt flag			



24.6.32 GPIO_IEN - Interrupt Enable

Offset	Bit Position																															
0x424	31	30	29	28	27	26	25	24	23	22	21	20	19	18	17	16	15	14	13	12	11	10	9	8	7	6	5	4	3	2	1	0
Reset					0x0	0x0	0x0	0x0	0x0	0x0	0x0	0x0	0x0	0x0	0x0	0x0					0x0	0x0	0x0	0x0	0x0	0x0	0x0	0x0	0x0	0x0	0x0	0x0
Access					RW	RW	RW	RW	RW	RW	RW	RW	RW	RW	RW						RW	RW	RW	RW	RW	RW	RW	RW	RW	RW	RW	RW
Name					EM4WUIEN11	EM4WUIEN10	EM4WUIEN9	EM4WUIEN8	EM4WUIEN7	EM4WUIEN6	EM4WUIEN5	EM4WUIEN4	EM4WUIEN3	EM4WUIEN2	EM4WUIEN1	EM4WUIEN0					EXTIEN11	EXTIEN10	EXTIEN9	EXTIEN8	EXTIEN7	EXTIEN6	EXTIEN5	EXTIEN4	EXTIEN3	EXTIEN2	EXTIEN1	EXTIEN0

Bit	Name	Reset	Access	Description
31:28	<i>Reserved</i>	<i>To ensure compatibility with future devices, always write Reserved bits to their reset value, unless otherwise stated. More information in 1.2 Conventions</i>		
27	EM4WUIEN11 EM4 wakeup interrupt enable	0x0	RW	EM4 Wake Up Interrupt En
26	EM4WUIEN10 EM4 wakeup interrupt enable	0x0	RW	EM4 Wake Up Interrupt En
25	EM4WUIEN9 EM4 wakeup interrupt enable	0x0	RW	EM4 Wake Up Interrupt En
24	EM4WUIEN8 EM4 wakeup interrupt enable	0x0	RW	EM4 Wake Up Interrupt En
23	EM4WUIEN7 EM4 wakeup interrupt enable	0x0	RW	EM4 Wake Up Interrupt En
22	EM4WUIEN6 EM4 wakeup interrupt enable	0x0	RW	EM4 Wake Up Interrupt En
21	EM4WUIEN5 EM4 wakeup interrupt enable	0x0	RW	EM4 Wake Up Interrupt En
20	EM4WUIEN4 EM4 wakeup interrupt enable	0x0	RW	EM4 Wake Up Interrupt En
19	EM4WUIEN3 EM4 wakeup interrupt enable	0x0	RW	EM4 Wake Up Interrupt En
18	EM4WUIEN2 EM4 wakeup interrupt enable	0x0	RW	EM4 Wake Up Interrupt En
17	EM4WUIEN1 EM4 wakeup interrupt enable	0x0	RW	EM4 Wake Up Interrupt En
16	EM4WUIEN0 EM4 wakeup interrupt enable	0x0	RW	EM4 Wake Up Interrupt En
15:12	<i>Reserved</i>	<i>To ensure compatibility with future devices, always write Reserved bits to their reset value, unless otherwise stated. More information in 1.2 Conventions</i>		

Bit	Name	Reset	Access	Description
11	EXTIEN11	0x0	RW	External Pin Enable External Pin interrupt enable
10	EXTIEN10	0x0	RW	External Pin Enable External Pin interrupt enable
9	EXTIEN9	0x0	RW	External Pin Enable External Pin interrupt enable
8	EXTIEN8	0x0	RW	External Pin Enable External Pin interrupt enable
7	EXTIEN7	0x0	RW	External Pin Enable External Pin interrupt enable
6	EXTIEN6	0x0	RW	External Pin Enable External Pin interrupt enable
5	EXTIEN5	0x0	RW	External Pin Enable External Pin interrupt enable
4	EXTIEN4	0x0	RW	External Pin Enable External Pin interrupt enable
3	EXTIEN3	0x0	RW	External Pin Enable External Pin interrupt enable
2	EXTIEN2	0x0	RW	External Pin Enable External Pin interrupt enable
1	EXTIEN1	0x0	RW	External Pin Enable External Pin interrupt enable
0	EXTIEN0	0x0	RW	External Pin Enable External Pin interrupt enable

24.6.33 GPIO_EM4WUEN - EM4 Wakeup Enable

Offset	Bit Position																															
0x42C	31	30	29	28	27	26	25	24	23	22	21	20	19	18	17	16	15	14	13	12	11	10	9	8	7	6	5	4	3	2	1	0
Reset																	0x0															
Access																	RW															
Name																	EM4WUEN															

Bit	Name	Reset	Access	Description
31:28	Reserved			To ensure compatibility with future devices, always write Reserved bits to their reset value, unless otherwise stated. More information in 1.2 Conventions
27:16	EM4WUEN	0x0	RW	EM4 wake up enable Write 1 to enable EM4 wake up request, write 0 to disable EM4 wake up request
15:0	Reserved			To ensure compatibility with future devices, always write Reserved bits to their reset value, unless otherwise stated. More information in 1.2 Conventions

24.6.34 GPIO_EM4WUPOL - EM4 Wakeup Polarity

Offset	Bit Position																															
0x430	31	30	29	28	27	26	25	24	23	22	21	20	19	18	17	16	15	14	13	12	11	10	9	8	7	6	5	4	3	2	1	0
Reset																	0x0															
Access																	RW															
Name																	EM4WUPOL															

Bit	Name	Reset	Access	Description
31:28	Reserved			To ensure compatibility with future devices, always write Reserved bits to their reset value, unless otherwise stated. More information in 1.2 Conventions
27:16	EM4WUPOL EM4 Wakeup Polarity	0x0	RW	EM4 Wake-Up Polarity
15:0	Reserved			To ensure compatibility with future devices, always write Reserved bits to their reset value, unless otherwise stated. More information in 1.2 Conventions

24.6.35 GPIO_DBGROUPEPEN - Debugger Route Pin Enable

Offset	Bit Position																															
0x440	31	30	29	28	27	26	25	24	23	22	21	20	19	18	17	16	15	14	13	12	11	10	9	8	7	6	5	4	3	2	1	0
Reset																											0x1	0x1	0x1	0x1		
Access																											RW	RW	RW	RW		
Name																											TDIPEN	TDOPEN	SWDIOTMSPEN	SWCLKTCKPEN		

Bit	Name	Reset	Access	Description
31:4	<i>Reserved</i>	<i>To ensure compatibility with future devices, always write Reserved bits to their reset value, unless otherwise stated. More information in 1.2 Conventions</i>		
3	TDIPEN	0x1	RW	JTAG Test Debug Input Pin Enable Enable JTAG TDI connection to pin.
2	TDOPEN	0x1	RW	JTAG Test Debug Output Pin Enable Enable JTAG TDO connection to pin.
1	SWDIOTMSPEN	0x1	RW	Route Location 0 Enable Serial Wire Data and JTAG Test Mode Select connection to pin. WARNING: When the pin is disabled, the device can no longer be accessed by a debugger. A reset will set the pin back to a default state as enabled. If you disable this pin, make sure you have at least a 3 second timeout at the start of your program code before you disable the pin. This way, the debugger will have time to halt the device after a reset before the pin is disabled.
0	SWCLKTCKPEN	0x1	RW	Route Pin Enable Enable Serial Wire and JTAG CLock connection to pin. WARNING: When the pin is disabled, the device can no longer be accessed by a debugger. A reset will set the pin back to a default state as enabled. If you disable this pin, make sure you have at least a 3 second timeout at the start of your program code before you disable the pin. This way, the debugger will have time to halt the device after a reset before the pin is disabled.

24.6.36 GPIO_TRACEROUTEPEN - Trace Route Pin Enable

Offset	Bit Position																																																								
0x444	31	30	29	28	27	26	25	24	23	22	21	20	19	18	17	16	15	14	13	12	11	10	9	8	7	6	5	4	3	2	1	0																									
Reset																											0x0	0x0	0x0	0x0	0x0	0x0	0x0	0x0	0x0	0x0	0x0	0x0	0x0	0x0	0x0	0x0	0x0	0x0	0x0	0x0	0x0	0x0	0x0	0x0	0x0	0x0	0x0	0x0	0x0	0x0	
Access																											RW	RW	RW	RW	RW	RW	RW	RW	RW	RW	RW	RW	RW	RW	RW	RW	RW	RW	RW	RW	RW	RW	RW	RW	RW	RW	RW	RW	RW	RW	RW
Name																											TRACEDATA3PEN	TRACEDATA2PEN	TRACEDATA1PEN	TRACEDATA0PEN	TRACEDATA0PEN	TRACEDATA0PEN	TRACEDATA0PEN	TRACEDATA0PEN	TRACEDATA0PEN	TRACEDATA0PEN	TRACEDATA0PEN	TRACEDATA0PEN	TRACEDATA0PEN	TRACEDATA0PEN	TRACEDATA0PEN	TRACEDATA0PEN	TRACEDATA0PEN	TRACEDATA0PEN	TRACEDATA0PEN	TRACEDATA0PEN	TRACEDATA0PEN	TRACEDATA0PEN	TRACEDATA0PEN	TRACEDATA0PEN	TRACEDATA0PEN	TRACEDATA0PEN	TRACEDATA0PEN	TRACEDATA0PEN	TRACEDATA0PEN	TRACEDATA0PEN	TRACEDATA0PEN

Bit	Name	Reset	Access	Description
31:6	<i>Reserved</i>	<i>To ensure compatibility with future devices, always write Reserved bits to their reset value, unless otherwise stated. More information in 1.2 Conventions</i>		
5	TRACEDATA3PEN Trace Data3 Pin Enable	0x0	RW	Trace Data3 Pin Enable
4	TRACEDATA2PEN Trace Data2 Pin Enable	0x0	RW	Trace Data2 Pin Enable
3	TRACEDATA1PEN Trace Data1 Pin Enable	0x0	RW	Trace Data1 Pin Enable
2	TRACEDATA0PEN Trace Data0 Pin Enable	0x0	RW	Trace Data0 Pin Enable
1	TRACECLKPEN Trace Clk Pin Enable	0x0	RW	Trace Clk Pin Enable
0	SWVPEN Serial Wire Viewer Output Pin Enable	0x0	RW	Serial Wire Viewer Output Pin Enable

24.6.37 GPIO_ACMPO_ROUTEEN - ACMPO Pin Enable

Offset	Bit Position																															
0x450	31	30	29	28	27	26	25	24	23	22	21	20	19	18	17	16	15	14	13	12	11	10	9	8	7	6	5	4	3	2	1	0
Reset																																0x0
Access																																RW
Name																																ACMPOUTPEN

Bit	Name	Reset	Access	Description
31:1	Reserved			To ensure compatibility with future devices, always write Reserved bits to their reset value, unless otherwise stated. More information in 1.2 Conventions
0	ACMPOUTPEN	0x0	RW	ACMPOUT pin enable control bit ACMPOUT pin enable control bit

24.6.38 GPIO_ACMPO_ACMPOUTROUTE - ACMPOUT Port/Pin Select

Offset	Bit Position																																
0x454	31	30	29	28	27	26	25	24	23	22	21	20	19	18	17	16	15	14	13	12	11	10	9	8	7	6	5	4	3	2	1	0	
Reset																	0x0																0x0
Access																	RW																RW
Name																	PIN																PORT

Bit	Name	Reset	Access	Description
31:20	Reserved			To ensure compatibility with future devices, always write Reserved bits to their reset value, unless otherwise stated. More information in 1.2 Conventions
19:16	PIN	0x0	RW	ACMPOUT pin select register ACMPOUT pin select register
15:2	Reserved			To ensure compatibility with future devices, always write Reserved bits to their reset value, unless otherwise stated. More information in 1.2 Conventions
1:0	PORT	0x0	RW	ACMPOUT port select register ACMPOUT port select register

24.6.39 GPIO_ACMPI_ROUTEEN - ACMPI Pin Enable

Offset	Bit Position																															
0x45C	31	30	29	28	27	26	25	24	23	22	21	20	19	18	17	16	15	14	13	12	11	10	9	8	7	6	5	4	3	2	1	0
Reset																																0x0
Access																																RW
Name																																ACMPOUTPEN

Bit	Name	Reset	Access	Description
31:1	Reserved	To ensure compatibility with future devices, always write Reserved bits to their reset value, unless otherwise stated. More information in 1.2 Conventions		
0	ACMPOUTPEN	0x0	RW	ACMPOUT pin enable control bit ACMPOUT pin enable control bit

24.6.40 GPIO_ACMPI_ACMPOUTROUTE - ACMPOUT Port/Pin Select

Offset	Bit Position																																
0x460	31	30	29	28	27	26	25	24	23	22	21	20	19	18	17	16	15	14	13	12	11	10	9	8	7	6	5	4	3	2	1	0	
Reset																	0x0																0x0
Access																	RW																RW
Name																	PIN																PORT

Bit	Name	Reset	Access	Description
31:20	Reserved	To ensure compatibility with future devices, always write Reserved bits to their reset value, unless otherwise stated. More information in 1.2 Conventions		
19:16	PIN	0x0	RW	ACMPOUT pin select register ACMPOUT pin select register
15:2	Reserved	To ensure compatibility with future devices, always write Reserved bits to their reset value, unless otherwise stated. More information in 1.2 Conventions		
1:0	PORT	0x0	RW	ACMPOUT port select register ACMPOUT port select register

24.6.41 GPIO_CMU_ROUTEEN - CMU Pin Enable

Offset	Bit Position																															
0x468	31	30	29	28	27	26	25	24	23	22	21	20	19	18	17	16	15	14	13	12	11	10	9	8	7	6	5	4	3	2	1	0
Reset																	0x0	0x0	0x0													
Access																	RW	RW	RW													
Name																	CLKOUT2PEN	CLKOUT1PEN	CLKOUT0PEN													

Bit	Name	Reset	Access	Description
31:3	<i>Reserved</i>	<i>To ensure compatibility with future devices, always write Reserved bits to their reset value, unless otherwise stated. More information in 1.2 Conventions</i>		
2	CLKOUT2PEN CLKOUT2 pin enable control bit	0x0	RW	CLKOUT2 pin enable control bit
1	CLKOUT1PEN CLKOUT1 pin enable control bit	0x0	RW	CLKOUT1 pin enable control bit
0	CLKOUT0PEN CLKOUT0 pin enable control bit	0x0	RW	CLKOUT0 pin enable control bit

24.6.42 GPIO_CMU_CLKIN0ROUTE - CLKIN0 Port/Pin Select

Offset	Bit Position																															
0x46C	31	30	29	28	27	26	25	24	23	22	21	20	19	18	17	16	15	14	13	12	11	10	9	8	7	6	5	4	3	2	1	0
Reset																	0x0											0x0				
Access																	RW											RW				
Name																	PIN											PORT				

Bit	Name	Reset	Access	Description
31:20	<i>Reserved</i>	<i>To ensure compatibility with future devices, always write Reserved bits to their reset value, unless otherwise stated. More information in 1.2 Conventions</i>		
19:16	PIN CLKIN0 pin select register	0x0	RW	CLKIN0 pin select register
15:2	<i>Reserved</i>	<i>To ensure compatibility with future devices, always write Reserved bits to their reset value, unless otherwise stated. More information in 1.2 Conventions</i>		
1:0	PORT CLKIN0 port select register	0x0	RW	CLKIN0 port select register

24.6.43 GPIO_CMU_CLKOUT0ROUTE - CLKOUT0 Port/Pin Select

Offset	Bit Position																															
0x470	31	30	29	28	27	26	25	24	23	22	21	20	19	18	17	16	15	14	13	12	11	10	9	8	7	6	5	4	3	2	1	0
Reset														0x0																0x0		
Access														RW																RW		
Name														PIN																PORT		

Bit	Name	Reset	Access	Description
31:20	Reserved	To ensure compatibility with future devices, always write Reserved bits to their reset value, unless otherwise stated. More information in 1.2 Conventions		
19:16	PIN CLKOUT0 pin select register	0x0	RW	CLKOUT0 pin select register
15:2	Reserved	To ensure compatibility with future devices, always write Reserved bits to their reset value, unless otherwise stated. More information in 1.2 Conventions		
1:0	PORT CLKOUT0 port select register	0x0	RW	CLKOUT0 port select register

24.6.44 GPIO_CMU_CLKOUT1ROUTE - CLKOUT1 Port/Pin Select

Offset	Bit Position																															
0x474	31	30	29	28	27	26	25	24	23	22	21	20	19	18	17	16	15	14	13	12	11	10	9	8	7	6	5	4	3	2	1	0
Reset														0x0																0x0		
Access														RW																RW		
Name														PIN																PORT		

Bit	Name	Reset	Access	Description
31:20	Reserved	To ensure compatibility with future devices, always write Reserved bits to their reset value, unless otherwise stated. More information in 1.2 Conventions		
19:16	PIN CLKOUT1 pin select register	0x0	RW	CLKOUT1 pin select register
15:2	Reserved	To ensure compatibility with future devices, always write Reserved bits to their reset value, unless otherwise stated. More information in 1.2 Conventions		
1:0	PORT CLKOUT1 port select register	0x0	RW	CLKOUT1 port select register

24.6.45 GPIO_CMU_CLKOUT2ROUTE - CLKOUT2 Port/Pin Select

Offset	Bit Position																															
0x478	31	30	29	28	27	26	25	24	23	22	21	20	19	18	17	16	15	14	13	12	11	10	9	8	7	6	5	4	3	2	1	0
Reset													0x0																0x0			
Access													RW																RW			
Name													PIN																PORT			

Bit	Name	Reset	Access	Description
31:20	Reserved	To ensure compatibility with future devices, always write Reserved bits to their reset value, unless otherwise stated. More information in 1.2 Conventions		
19:16	PIN CLKOUT2 pin select register	0x0	RW	CLKOUT2 pin select register
15:2	Reserved	To ensure compatibility with future devices, always write Reserved bits to their reset value, unless otherwise stated. More information in 1.2 Conventions		
1:0	PORT CLKOUT2 port select register	0x0	RW	CLKOUT2 port select register

24.6.46 GPIO_EUSART0_ROUTEEN - EUSART0 Pin Enable

Offset	Bit Position																															
0x494	31	30	29	28	27	26	25	24	23	22	21	20	19	18	17	16	15	14	13	12	11	10	9	8	7	6	5	4	3	2	1	0
Reset																											0x0	0x0	0x0	0x0	0x0	
Access																											RW	RW	RW	RW	RW	
Name																											TXPEN	SCLKPEN	RXPEN	RTSPEN	CSPEN	

Bit	Name	Reset	Access	Description
31:5	<i>Reserved</i>	<i>To ensure compatibility with future devices, always write Reserved bits to their reset value, unless otherwise stated. More information in 1.2 Conventions</i>		
4	TXPEN TX pin enable control bit	0x0	RW	TX pin enable control bit
3	SCLKPEN SCLK pin enable control bit	0x0	RW	SCLK pin enable control bit
2	RXPEN RX pin enable control bit	0x0	RW	RX pin enable control bit
1	RTSPEN RTS pin enable control bit	0x0	RW	RTS pin enable control bit
0	CSPEN CS pin enable control bit	0x0	RW	CS pin enable control bit

24.6.47 GPIO_EUSART0_CSROUTE - CS Port/Pin Select

Offset	Bit Position																															
0x498	31	30	29	28	27	26	25	24	23	22	21	20	19	18	17	16	15	14	13	12	11	10	9	8	7	6	5	4	3	2	1	0
Reset													0x0												0x0							
Access													RW												RW							
Name													PIN												PORT							

Bit	Name	Reset	Access	Description
31:20	Reserved	To ensure compatibility with future devices, always write Reserved bits to their reset value, unless otherwise stated. More information in 1.2 Conventions		
19:16	PIN CS pin select register	0x0	RW	CS pin select register
15:2	Reserved	To ensure compatibility with future devices, always write Reserved bits to their reset value, unless otherwise stated. More information in 1.2 Conventions		
1:0	PORT CS port select register	0x0	RW	CS port select register

24.6.48 GPIO_EUSART0_CTSROUTE - CTS Port/Pin Select

Offset	Bit Position																															
0x49C	31	30	29	28	27	26	25	24	23	22	21	20	19	18	17	16	15	14	13	12	11	10	9	8	7	6	5	4	3	2	1	0
Reset													0x0												0x0							
Access													RW												RW							
Name													PIN												PORT							

Bit	Name	Reset	Access	Description
31:20	Reserved	To ensure compatibility with future devices, always write Reserved bits to their reset value, unless otherwise stated. More information in 1.2 Conventions		
19:16	PIN CTS pin select register	0x0	RW	CTS pin select register
15:2	Reserved	To ensure compatibility with future devices, always write Reserved bits to their reset value, unless otherwise stated. More information in 1.2 Conventions		
1:0	PORT CTS port select register	0x0	RW	CTS port select register

24.6.49 GPIO_EUSART0_RTROUTE - RTS Port/Pin Select

Offset	Bit Position																															
0x4A0	31	30	29	28	27	26	25	24	23	22	21	20	19	18	17	16	15	14	13	12	11	10	9	8	7	6	5	4	3	2	1	0
Reset														0x0																0x0		
Access														RW																RW		
Name														PIN																PORT		

Bit	Name	Reset	Access	Description
31:20	Reserved	To ensure compatibility with future devices, always write Reserved bits to their reset value, unless otherwise stated. More information in 1.2 Conventions		
19:16	PIN RTS pin select register	0x0	RW	RTS pin select register
15:2	Reserved	To ensure compatibility with future devices, always write Reserved bits to their reset value, unless otherwise stated. More information in 1.2 Conventions		
1:0	PORT RTS port select register	0x0	RW	RTS port select register

24.6.50 GPIO_EUSART0_RXROUTE - RX Port/Pin Select

Offset	Bit Position																															
0x4A4	31	30	29	28	27	26	25	24	23	22	21	20	19	18	17	16	15	14	13	12	11	10	9	8	7	6	5	4	3	2	1	0
Reset														0x0																0x0		
Access														RW																RW		
Name														PIN																PORT		

Bit	Name	Reset	Access	Description
31:20	Reserved	To ensure compatibility with future devices, always write Reserved bits to their reset value, unless otherwise stated. More information in 1.2 Conventions		
19:16	PIN RX pin select register	0x0	RW	RX pin select register
15:2	Reserved	To ensure compatibility with future devices, always write Reserved bits to their reset value, unless otherwise stated. More information in 1.2 Conventions		
1:0	PORT RX port select register	0x0	RW	RX port select register

24.6.51 GPIO_EUSART0_SCLKROUTE - SCLK Port/Pin Select

Offset	Bit Position																															
0x4A8	31	30	29	28	27	26	25	24	23	22	21	20	19	18	17	16	15	14	13	12	11	10	9	8	7	6	5	4	3	2	1	0
Reset														0x0																0x0		
Access														RW																RW		
Name														PIN																PORT		

Bit	Name	Reset	Access	Description
31:20	Reserved	To ensure compatibility with future devices, always write Reserved bits to their reset value, unless otherwise stated. More information in 1.2 Conventions		
19:16	PIN SCLK pin select register	0x0	RW	SCLK pin select register
15:2	Reserved	To ensure compatibility with future devices, always write Reserved bits to their reset value, unless otherwise stated. More information in 1.2 Conventions		
1:0	PORT SCLK port select register	0x0	RW	SCLK port select register

24.6.52 GPIO_EUSART0_TXROUTE - TX Port/Pin Select

Offset	Bit Position																															
0x4AC	31	30	29	28	27	26	25	24	23	22	21	20	19	18	17	16	15	14	13	12	11	10	9	8	7	6	5	4	3	2	1	0
Reset														0x0																0x0		
Access														RW																RW		
Name														PIN																PORT		

Bit	Name	Reset	Access	Description
31:20	Reserved	To ensure compatibility with future devices, always write Reserved bits to their reset value, unless otherwise stated. More information in 1.2 Conventions		
19:16	PIN TX pin select register	0x0	RW	TX pin select register
15:2	Reserved	To ensure compatibility with future devices, always write Reserved bits to their reset value, unless otherwise stated. More information in 1.2 Conventions		
1:0	PORT TX port select register	0x0	RW	TX port select register

24.6.53 GPIO_EUSART1_ROUTEEN - EUSART1 Pin Enable

Offset	Bit Position																																														
	31	30	29	28	27	26	25	24	23	22	21	20	19	18	17	16	15	14	13	12	11	10	9	8	7	6	5	4	3	2	1	0															
0x4B4																																															
Reset																																					0x0	0x0	0x0	0x0	0x0						
Access																																							RW	RW	RW	RW	RW	RW			
Name																																											TXPEN	SCLKPEN	RXPEN	RTSPEN	CSPEN

Bit	Name	Reset	Access	Description
31:5	<i>Reserved</i>			<i>To ensure compatibility with future devices, always write Reserved bits to their reset value, unless otherwise stated. More information in 1.2 Conventions</i>
4	TXPEN TX pin enable control bit	0x0	RW	TX pin enable control bit
3	SCLKPEN SCLK pin enable control bit	0x0	RW	SCLK pin enable control bit
2	RXPEN RX pin enable control bit	0x0	RW	RX pin enable control bit
1	RTSPEN RTS pin enable control bit	0x0	RW	RTS pin enable control bit
0	CSPEN CS pin enable control bit	0x0	RW	CS pin enable control bit

24.6.54 GPIO_EUSART1_CSROUTE - CS Port/Pin Select

Offset	Bit Position																															
0x4B8	31	30	29	28	27	26	25	24	23	22	21	20	19	18	17	16	15	14	13	12	11	10	9	8	7	6	5	4	3	2	1	0
Reset														0x0																0x0		
Access														RW																RW		
Name														PIN																PORT		

Bit	Name	Reset	Access	Description
31:20	Reserved	To ensure compatibility with future devices, always write Reserved bits to their reset value, unless otherwise stated. More information in 1.2 Conventions		
19:16	PIN CS pin select register	0x0	RW	CS pin select register
15:2	Reserved	To ensure compatibility with future devices, always write Reserved bits to their reset value, unless otherwise stated. More information in 1.2 Conventions		
1:0	PORT CS port select register	0x0	RW	CS port select register

24.6.55 GPIO_EUSART1_CTSROUTE - CTS Port/Pin Select

Offset	Bit Position																															
0x4BC	31	30	29	28	27	26	25	24	23	22	21	20	19	18	17	16	15	14	13	12	11	10	9	8	7	6	5	4	3	2	1	0
Reset														0x0																0x0		
Access														RW																RW		
Name														PIN																PORT		

Bit	Name	Reset	Access	Description
31:20	Reserved	To ensure compatibility with future devices, always write Reserved bits to their reset value, unless otherwise stated. More information in 1.2 Conventions		
19:16	PIN CTS pin select register	0x0	RW	CTS pin select register
15:2	Reserved	To ensure compatibility with future devices, always write Reserved bits to their reset value, unless otherwise stated. More information in 1.2 Conventions		
1:0	PORT CTS port select register	0x0	RW	CTS port select register

24.6.56 GPIO_EUSART1_RTROUTE - RTS Port/Pin Select

Offset	Bit Position																															
0x4C0	31	30	29	28	27	26	25	24	23	22	21	20	19	18	17	16	15	14	13	12	11	10	9	8	7	6	5	4	3	2	1	0
Reset														0x0													0x0					
Access														RW													RW					
Name														PIN													PORT					

Bit	Name	Reset	Access	Description
31:20	Reserved	To ensure compatibility with future devices, always write Reserved bits to their reset value, unless otherwise stated. More information in 1.2 Conventions		
19:16	PIN RTS pin select register	0x0	RW	RTS pin select register
15:2	Reserved	To ensure compatibility with future devices, always write Reserved bits to their reset value, unless otherwise stated. More information in 1.2 Conventions		
1:0	PORT RTS port select register	0x0	RW	RTS port select register

24.6.57 GPIO_EUSART1_RXROUTE - RX Port/Pin Select

Offset	Bit Position																															
0x4C4	31	30	29	28	27	26	25	24	23	22	21	20	19	18	17	16	15	14	13	12	11	10	9	8	7	6	5	4	3	2	1	0
Reset														0x0													0x0					
Access														RW													RW					
Name														PIN													PORT					

Bit	Name	Reset	Access	Description
31:20	Reserved	To ensure compatibility with future devices, always write Reserved bits to their reset value, unless otherwise stated. More information in 1.2 Conventions		
19:16	PIN RX pin select register	0x0	RW	RX pin select register
15:2	Reserved	To ensure compatibility with future devices, always write Reserved bits to their reset value, unless otherwise stated. More information in 1.2 Conventions		
1:0	PORT RX port select register	0x0	RW	RX port select register

24.6.58 GPIO_EUSART1_SCLKROUTE - SCLK Port/Pin Select

Offset	Bit Position																															
0x4C8	31	30	29	28	27	26	25	24	23	22	21	20	19	18	17	16	15	14	13	12	11	10	9	8	7	6	5	4	3	2	1	0
Reset													0x0																0x0			
Access													RW																RW			
Name													PIN																PORT			

Bit	Name	Reset	Access	Description
31:20	Reserved	To ensure compatibility with future devices, always write Reserved bits to their reset value, unless otherwise stated. More information in 1.2 Conventions		
19:16	PIN SCLK pin select register	0x0	RW	SCLK pin select register
15:2	Reserved	To ensure compatibility with future devices, always write Reserved bits to their reset value, unless otherwise stated. More information in 1.2 Conventions		
1:0	PORT SCLK port select register	0x0	RW	SCLK port select register

24.6.59 GPIO_EUSART1_TXROUTE - TX Port/Pin Select

Offset	Bit Position																															
0x4CC	31	30	29	28	27	26	25	24	23	22	21	20	19	18	17	16	15	14	13	12	11	10	9	8	7	6	5	4	3	2	1	0
Reset													0x0																0x0			
Access													RW																RW			
Name													PIN																PORT			

Bit	Name	Reset	Access	Description
31:20	Reserved	To ensure compatibility with future devices, always write Reserved bits to their reset value, unless otherwise stated. More information in 1.2 Conventions		
19:16	PIN TX pin select register	0x0	RW	TX pin select register
15:2	Reserved	To ensure compatibility with future devices, always write Reserved bits to their reset value, unless otherwise stated. More information in 1.2 Conventions		
1:0	PORT TX port select register	0x0	RW	TX port select register

24.6.60 GPIO_FRC_ROUTEEN - FRC Pin Enable

Offset	Bit Position																															
0x4D4	31	30	29	28	27	26	25	24	23	22	21	20	19	18	17	16	15	14	13	12	11	10	9	8	7	6	5	4	3	2	1	0
Reset																											0x0	0x0	0x0			
Access																											RW	RW	RW			
Name																											DOUTPEN	DFRAMEPEN	DCLKPEN			

Bit	Name	Reset	Access	Description
31:3	<i>Reserved</i>	<i>To ensure compatibility with future devices, always write Reserved bits to their reset value, unless otherwise stated. More information in 1.2 Conventions</i>		
2	DOUTPEN DOUT pin enable control bit	0x0	RW	DOUT pin enable control bit
1	DFRAMEPEN DFRAME pin enable control bit	0x0	RW	DFRAME pin enable control bit
0	DCLKPEN DCLK pin enable control bit	0x0	RW	DCLK pin enable control bit

24.6.61 GPIO_FRC_DCLKROUTE - DCLK Port/Pin Select

Offset	Bit Position																															
0x4D8	31	30	29	28	27	26	25	24	23	22	21	20	19	18	17	16	15	14	13	12	11	10	9	8	7	6	5	4	3	2	1	0
Reset																	0x0											0x0				
Access																	RW											RW				
Name																	PIN											PORT				

Bit	Name	Reset	Access	Description
31:20	<i>Reserved</i>	<i>To ensure compatibility with future devices, always write Reserved bits to their reset value, unless otherwise stated. More information in 1.2 Conventions</i>		
19:16	PIN DCLK pin select register	0x0	RW	DCLK pin select register
15:2	<i>Reserved</i>	<i>To ensure compatibility with future devices, always write Reserved bits to their reset value, unless otherwise stated. More information in 1.2 Conventions</i>		
1:0	PORT DCLK port select register	0x0	RW	DCLK port select register

24.6.62 GPIO_FRC_DFRAMEROUTE - DFRAME Port/Pin Select

Offset	Bit Position																															
0x4DC	31	30	29	28	27	26	25	24	23	22	21	20	19	18	17	16	15	14	13	12	11	10	9	8	7	6	5	4	3	2	1	0
Reset														0x0																0x0		
Access														RW																RW		
Name														PIN																PORT		

Bit	Name	Reset	Access	Description
31:20	Reserved	To ensure compatibility with future devices, always write Reserved bits to their reset value, unless otherwise stated. More information in 1.2 Conventions		
19:16	PIN	0x0	RW	DFRAME pin select register DFRAME pin select register
15:2	Reserved	To ensure compatibility with future devices, always write Reserved bits to their reset value, unless otherwise stated. More information in 1.2 Conventions		
1:0	PORT	0x0	RW	DFRAME port select register DFRAME port select register

24.6.63 GPIO_FRC_DOUTROUTE - DOUT Port/Pin Select

Offset	Bit Position																															
0x4E0	31	30	29	28	27	26	25	24	23	22	21	20	19	18	17	16	15	14	13	12	11	10	9	8	7	6	5	4	3	2	1	0
Reset														0x0																0x0		
Access														RW																RW		
Name														PIN																PORT		

Bit	Name	Reset	Access	Description
31:20	Reserved	To ensure compatibility with future devices, always write Reserved bits to their reset value, unless otherwise stated. More information in 1.2 Conventions		
19:16	PIN	0x0	RW	DOUT pin select register DOUT pin select register
15:2	Reserved	To ensure compatibility with future devices, always write Reserved bits to their reset value, unless otherwise stated. More information in 1.2 Conventions		
1:0	PORT	0x0	RW	DOUT port select register DOUT port select register

24.6.64 GPIO_I2C0_ROUTEEN - I2C0 Pin Enable

Offset	Bit Position																															
0x4E8	31	30	29	28	27	26	25	24	23	22	21	20	19	18	17	16	15	14	13	12	11	10	9	8	7	6	5	4	3	2	1	0
Reset																	0x0	0x0														
Access																	RW	RW														
Name																	SDAPEN	SCLPEN														

Bit	Name	Reset	Access	Description
31:2	Reserved	To ensure compatibility with future devices, always write Reserved bits to their reset value, unless otherwise stated. More information in 1.2 Conventions		
1	SDAPEN SDA pin enable control bit	0x0	RW	SDA pin enable control bit
0	SCLPEN SCL pin enable control bit	0x0	RW	SCL pin enable control bit

24.6.65 GPIO_I2C0_SCLROUTE - SCL Port/Pin Select

Offset	Bit Position																															
0x4EC	31	30	29	28	27	26	25	24	23	22	21	20	19	18	17	16	15	14	13	12	11	10	9	8	7	6	5	4	3	2	1	0
Reset													0x0															0x0				
Access													RW															RW				
Name													PIN															PORT				

Bit	Name	Reset	Access	Description
31:20	Reserved	To ensure compatibility with future devices, always write Reserved bits to their reset value, unless otherwise stated. More information in 1.2 Conventions		
19:16	PIN SCL pin select register	0x0	RW	SCL pin select register
15:2	Reserved	To ensure compatibility with future devices, always write Reserved bits to their reset value, unless otherwise stated. More information in 1.2 Conventions		
1:0	PORT SCL port select register	0x0	RW	SCL port select register

24.6.66 GPIO_I2C0_SDAROUTE - SDA Port/Pin Select

Offset	Bit Position																															
0x4F0	31	30	29	28	27	26	25	24	23	22	21	20	19	18	17	16	15	14	13	12	11	10	9	8	7	6	5	4	3	2	1	0
Reset														0x0													0x0					
Access														RW													RW					
Name														PIN													PORT					

Bit	Name	Reset	Access	Description
31:20	Reserved	To ensure compatibility with future devices, always write Reserved bits to their reset value, unless otherwise stated. More information in 1.2 Conventions		
19:16	PIN SDA pin select register	0x0	RW	SDA pin select register
15:2	Reserved	To ensure compatibility with future devices, always write Reserved bits to their reset value, unless otherwise stated. More information in 1.2 Conventions		
1:0	PORT SDA port select register	0x0	RW	SDA port select register

24.6.67 GPIO_I2C1_ROUTEEN - I2C1 Pin Enable

Offset	Bit Position																															
0x4F8	31	30	29	28	27	26	25	24	23	22	21	20	19	18	17	16	15	14	13	12	11	10	9	8	7	6	5	4	3	2	1	0
Reset																											0x0		0x0			
Access																											RW		RW			
Name																											SDAPEN		SCLPEN			

Bit	Name	Reset	Access	Description
31:2	Reserved	To ensure compatibility with future devices, always write Reserved bits to their reset value, unless otherwise stated. More information in 1.2 Conventions		
1	SDAPEN SDA pin enable control bit	0x0	RW	SDA pin enable control bit
0	SCLPEN SCL pin enable control bit	0x0	RW	SCL pin enable control bit

24.6.68 GPIO_I2C1_SCLROUTE - SCL Port/Pin Select

Offset	Bit Position																															
0x4FC	31	30	29	28	27	26	25	24	23	22	21	20	19	18	17	16	15	14	13	12	11	10	9	8	7	6	5	4	3	2	1	0
Reset													0x0																0x0			
Access													RW																RW			
Name													PIN																PORT			

Bit	Name	Reset	Access	Description
31:20	Reserved	To ensure compatibility with future devices, always write Reserved bits to their reset value, unless otherwise stated. More information in 1.2 Conventions		
19:16	PIN SCL pin select register	0x0	RW	SCL pin select register
15:2	Reserved	To ensure compatibility with future devices, always write Reserved bits to their reset value, unless otherwise stated. More information in 1.2 Conventions		
1:0	PORT SCL port select register	0x0	RW	SCL port select register

24.6.69 GPIO_I2C1_SDAROUTE - SDA Port/Pin Select

Offset	Bit Position																															
0x500	31	30	29	28	27	26	25	24	23	22	21	20	19	18	17	16	15	14	13	12	11	10	9	8	7	6	5	4	3	2	1	0
Reset													0x0																0x0			
Access													RW																RW			
Name													PIN																PORT			

Bit	Name	Reset	Access	Description
31:20	Reserved	To ensure compatibility with future devices, always write Reserved bits to their reset value, unless otherwise stated. More information in 1.2 Conventions		
19:16	PIN SDA pin select register	0x0	RW	SDA pin select register
15:2	Reserved	To ensure compatibility with future devices, always write Reserved bits to their reset value, unless otherwise stated. More information in 1.2 Conventions		
1:0	PORT SDA port select register	0x0	RW	SDA port select register

24.6.70 GPIO_KEYSCAN_ROUTEEN - KEYSKAN Pin Enable

Offset	Bit Position																																																					
0x508	31	30	29	28	27	26	25	24	23	22	21	20	19	18	17	16	15	14	13	12	11	10	9	8	7	6	5	4	3	2	1	0																						
Reset																								0x0	0x0	0x0	0x0	0x0	0x0	0x0	0x0	0x0	0x0	0x0	0x0	0x0	0x0	0x0	0x0	0x0	0x0	0x0	0x0	0x0	0x0	0x0	0x0	0x0	0x0	0x0	0x0	0x0	0x0	
Access																								RW	RW	RW	RW	RW	RW	RW	RW	RW	RW	RW	RW	RW	RW	RW	RW	RW	RW	RW	RW	RW	RW	RW	RW	RW	RW	RW	RW	RW	RW	RW
Name																								COLOUT7PEN	COLOUT6PEN	COLOUT5PEN	COLOUT4PEN	COLOUT3PEN	COLOUT2PEN	COLOUT1PEN	COLOUT0PEN																							

Bit	Name	Reset	Access	Description
31:8	<i>Reserved</i>	<i>To ensure compatibility with future devices, always write Reserved bits to their reset value, unless otherwise stated. More information in 1.2 Conventions</i>		
7	COLOUT7PEN COLOUT7 pin enable control bit	0x0	RW	COLOUT7 pin enable control bit
6	COLOUT6PEN COLOUT6 pin enable control bit	0x0	RW	COLOUT6 pin enable control bit
5	COLOUT5PEN COLOUT5 pin enable control bit	0x0	RW	COLOUT5 pin enable control bit
4	COLOUT4PEN COLOUT4 pin enable control bit	0x0	RW	COLOUT4 pin enable control bit
3	COLOUT3PEN COLOUT3 pin enable control bit	0x0	RW	COLOUT3 pin enable control bit
2	COLOUT2PEN COLOUT2 pin enable control bit	0x0	RW	COLOUT2 pin enable control bit
1	COLOUT1PEN COLOUT1 pin enable control bit	0x0	RW	COLOUT1 pin enable control bit
0	COLOUT0PEN COLOUT0 pin enable control bit	0x0	RW	COLOUT0 pin enable control bit

24.6.71 GPIO_KEYSCAN_COLOUT0ROUTE - COLOUT0 Port/Pin Select

Offset	Bit Position																															
0x50C	31	30	29	28	27	26	25	24	23	22	21	20	19	18	17	16	15	14	13	12	11	10	9	8	7	6	5	4	3	2	1	0
Reset													0x0																0x0			
Access													RW																RW			
Name													PIN																PORT			

Bit	Name	Reset	Access	Description
31:20	Reserved	To ensure compatibility with future devices, always write Reserved bits to their reset value, unless otherwise stated. More information in 1.2 Conventions		
19:16	PIN COLOUT0 pin select register	0x0	RW	COLOUT0 pin select register
15:2	Reserved	To ensure compatibility with future devices, always write Reserved bits to their reset value, unless otherwise stated. More information in 1.2 Conventions		
1:0	PORT COLOUT0 port select register	0x0	RW	COLOUT0 port select register

24.6.72 GPIO_KEYSCAN_COLOUT1ROUTE - COLOUT1 Port/Pin Select

Offset	Bit Position																															
0x510	31	30	29	28	27	26	25	24	23	22	21	20	19	18	17	16	15	14	13	12	11	10	9	8	7	6	5	4	3	2	1	0
Reset													0x0																0x0			
Access													RW																RW			
Name													PIN																PORT			

Bit	Name	Reset	Access	Description
31:20	Reserved	To ensure compatibility with future devices, always write Reserved bits to their reset value, unless otherwise stated. More information in 1.2 Conventions		
19:16	PIN COLOUT1 pin select register	0x0	RW	COLOUT1 pin select register
15:2	Reserved	To ensure compatibility with future devices, always write Reserved bits to their reset value, unless otherwise stated. More information in 1.2 Conventions		
1:0	PORT COLOUT1 port select register	0x0	RW	COLOUT1 port select register

24.6.73 GPIO_KEYSCAN_COLOUT2ROUTE - COLOUT2 Port/Pin Select

Offset	Bit Position																															
0x514	31	30	29	28	27	26	25	24	23	22	21	20	19	18	17	16	15	14	13	12	11	10	9	8	7	6	5	4	3	2	1	0
Reset													0x0																0x0			
Access													RW																RW			
Name													PIN																PORT			

Bit	Name	Reset	Access	Description
31:20	Reserved	<i>To ensure compatibility with future devices, always write Reserved bits to their reset value, unless otherwise stated. More information in 1.2 Conventions</i>		
19:16	PIN COLOUT2 pin select register	0x0	RW	COLOUT2 pin select register
15:2	Reserved	<i>To ensure compatibility with future devices, always write Reserved bits to their reset value, unless otherwise stated. More information in 1.2 Conventions</i>		
1:0	PORT COLOUT2 port select register	0x0	RW	COLOUT2 port select register

24.6.74 GPIO_KEYSCAN_COLOUT3ROUTE - COLOUT3 Port/Pin Select

Offset	Bit Position																															
0x518	31	30	29	28	27	26	25	24	23	22	21	20	19	18	17	16	15	14	13	12	11	10	9	8	7	6	5	4	3	2	1	0
Reset													0x0																0x0			
Access													RW																RW			
Name													PIN																PORT			

Bit	Name	Reset	Access	Description
31:20	Reserved	<i>To ensure compatibility with future devices, always write Reserved bits to their reset value, unless otherwise stated. More information in 1.2 Conventions</i>		
19:16	PIN COLOUT3 pin select register	0x0	RW	COLOUT3 pin select register
15:2	Reserved	<i>To ensure compatibility with future devices, always write Reserved bits to their reset value, unless otherwise stated. More information in 1.2 Conventions</i>		
1:0	PORT COLOUT3 port select register	0x0	RW	COLOUT3 port select register

24.6.75 GPIO_KEYSCAN_COLOUT4ROUTE - COLOUT4 Port/Pin Select

Offset	Bit Position																															
0x51C	31	30	29	28	27	26	25	24	23	22	21	20	19	18	17	16	15	14	13	12	11	10	9	8	7	6	5	4	3	2	1	0
Reset													0x0																0x0			
Access													RW																RW			
Name													PIN																PORT			

Bit	Name	Reset	Access	Description
31:20	Reserved	<i>To ensure compatibility with future devices, always write Reserved bits to their reset value, unless otherwise stated. More information in 1.2 Conventions</i>		
19:16	PIN COLOUT4 pin select register	0x0	RW	COLOUT4 pin select register
15:2	Reserved	<i>To ensure compatibility with future devices, always write Reserved bits to their reset value, unless otherwise stated. More information in 1.2 Conventions</i>		
1:0	PORT COLOUT4 port select register	0x0	RW	COLOUT4 port select register

24.6.76 GPIO_KEYSCAN_COLOUT5ROUTE - COLOUT5 Port/Pin Select

Offset	Bit Position																															
0x520	31	30	29	28	27	26	25	24	23	22	21	20	19	18	17	16	15	14	13	12	11	10	9	8	7	6	5	4	3	2	1	0
Reset													0x0																0x0			
Access													RW																RW			
Name													PIN																PORT			

Bit	Name	Reset	Access	Description
31:20	Reserved	<i>To ensure compatibility with future devices, always write Reserved bits to their reset value, unless otherwise stated. More information in 1.2 Conventions</i>		
19:16	PIN COLOUT5 pin select register	0x0	RW	COLOUT5 pin select register
15:2	Reserved	<i>To ensure compatibility with future devices, always write Reserved bits to their reset value, unless otherwise stated. More information in 1.2 Conventions</i>		
1:0	PORT COLOUT5 port select register	0x0	RW	COLOUT5 port select register

24.6.77 GPIO_KEYSCAN_COLOUT6ROUTE - COLOUT6 Port/Pin Select

Offset	Bit Position																															
0x524	31	30	29	28	27	26	25	24	23	22	21	20	19	18	17	16	15	14	13	12	11	10	9	8	7	6	5	4	3	2	1	0
Reset													0x0																0x0			
Access													RW																RW			
Name													PIN																PORT			

Bit	Name	Reset	Access	Description
31:20	Reserved	<i>To ensure compatibility with future devices, always write Reserved bits to their reset value, unless otherwise stated. More information in 1.2 Conventions</i>		
19:16	PIN COLOUT6 pin select register	0x0	RW	COLOUT6 pin select register
15:2	Reserved	<i>To ensure compatibility with future devices, always write Reserved bits to their reset value, unless otherwise stated. More information in 1.2 Conventions</i>		
1:0	PORT COLOUT6 port select register	0x0	RW	COLOUT6 port select register

24.6.78 GPIO_KEYSCAN_COLOUT7ROUTE - COLOUT7 Port/Pin Select

Offset	Bit Position																															
0x528	31	30	29	28	27	26	25	24	23	22	21	20	19	18	17	16	15	14	13	12	11	10	9	8	7	6	5	4	3	2	1	0
Reset													0x0																0x0			
Access													RW																RW			
Name													PIN																PORT			

Bit	Name	Reset	Access	Description
31:20	Reserved	<i>To ensure compatibility with future devices, always write Reserved bits to their reset value, unless otherwise stated. More information in 1.2 Conventions</i>		
19:16	PIN COLOUT7 pin select register	0x0	RW	COLOUT7 pin select register
15:2	Reserved	<i>To ensure compatibility with future devices, always write Reserved bits to their reset value, unless otherwise stated. More information in 1.2 Conventions</i>		
1:0	PORT COLOUT7 port select register	0x0	RW	COLOUT7 port select register

24.6.79 GPIO_KEYSCAN_ROWSENSE0ROUTE - ROWSENSE0 Port/Pin Select

Offset	Bit Position																															
0x52C	31	30	29	28	27	26	25	24	23	22	21	20	19	18	17	16	15	14	13	12	11	10	9	8	7	6	5	4	3	2	1	0
Reset														0x0																0x0		
Access														RW																RW		
Name														PIN																PORT		

Bit	Name	Reset	Access	Description
31:20	Reserved	To ensure compatibility with future devices, always write Reserved bits to their reset value, unless otherwise stated. More information in 1.2 Conventions		
19:16	PIN ROWSENSE0 pin select register	0x0	RW	ROWSENSE0 pin select register
15:2	Reserved	To ensure compatibility with future devices, always write Reserved bits to their reset value, unless otherwise stated. More information in 1.2 Conventions		
1:0	PORT ROWSENSE0 port select register	0x0	RW	ROWSENSE0 port select register

24.6.80 GPIO_KEYSCAN_ROWSENSE1ROUTE - ROWSENSE1 Port/Pin Select

Offset	Bit Position																															
0x530	31	30	29	28	27	26	25	24	23	22	21	20	19	18	17	16	15	14	13	12	11	10	9	8	7	6	5	4	3	2	1	0
Reset														0x0																0x0		
Access														RW																RW		
Name														PIN																PORT		

Bit	Name	Reset	Access	Description
31:20	Reserved	To ensure compatibility with future devices, always write Reserved bits to their reset value, unless otherwise stated. More information in 1.2 Conventions		
19:16	PIN ROWSENSE1 pin select register	0x0	RW	ROWSENSE1 pin select register
15:2	Reserved	To ensure compatibility with future devices, always write Reserved bits to their reset value, unless otherwise stated. More information in 1.2 Conventions		
1:0	PORT ROWSENSE1 port select register	0x0	RW	ROWSENSE1 port select register

24.6.81 GPIO_KEYSCAN_ROWSENSE2ROUTE - ROWSENSE2 Port/Pin Select

Offset	Bit Position																															
0x534	31	30	29	28	27	26	25	24	23	22	21	20	19	18	17	16	15	14	13	12	11	10	9	8	7	6	5	4	3	2	1	0
Reset													0x0																0x0			
Access													RW																RW			
Name													PIN																PORT			

Bit	Name	Reset	Access	Description
31:20	Reserved			To ensure compatibility with future devices, always write Reserved bits to their reset value, unless otherwise stated. More information in 1.2 Conventions
19:16	PIN	0x0	RW	ROWSENSE2 pin select register ROWSENSE2 pin select register
15:2	Reserved			To ensure compatibility with future devices, always write Reserved bits to their reset value, unless otherwise stated. More information in 1.2 Conventions
1:0	PORT	0x0	RW	ROWSENSE2 port select register ROWSENSE2 port select register

24.6.82 GPIO_KEYSCAN_ROWSENSE3ROUTE - ROWSENSE3 Port/Pin Select

Offset	Bit Position																															
0x538	31	30	29	28	27	26	25	24	23	22	21	20	19	18	17	16	15	14	13	12	11	10	9	8	7	6	5	4	3	2	1	0
Reset													0x0																0x0			
Access													RW																RW			
Name													PIN																PORT			

Bit	Name	Reset	Access	Description
31:20	Reserved			To ensure compatibility with future devices, always write Reserved bits to their reset value, unless otherwise stated. More information in 1.2 Conventions
19:16	PIN	0x0	RW	ROWSENSE3 pin select register ROWSENSE3 pin select register
15:2	Reserved			To ensure compatibility with future devices, always write Reserved bits to their reset value, unless otherwise stated. More information in 1.2 Conventions
1:0	PORT	0x0	RW	ROWSENSE3 port select register ROWSENSE3 port select register

24.6.83 GPIO_KEYSCAN_ROWSENSE4ROUTE - ROWSENSE4 Port/Pin Select

Offset	Bit Position																															
0x53C	31	30	29	28	27	26	25	24	23	22	21	20	19	18	17	16	15	14	13	12	11	10	9	8	7	6	5	4	3	2	1	0
Reset													0x0																0x0			
Access													RW																RW			
Name													PIN																PORT			

Bit	Name	Reset	Access	Description
31:20	Reserved	To ensure compatibility with future devices, always write Reserved bits to their reset value, unless otherwise stated. More information in 1.2 Conventions		
19:16	PIN ROWSENSE4 pin select register	0x0	RW	ROWSENSE4 pin select register
15:2	Reserved	To ensure compatibility with future devices, always write Reserved bits to their reset value, unless otherwise stated. More information in 1.2 Conventions		
1:0	PORT ROWSENSE4 port select register	0x0	RW	ROWSENSE4 port select register

24.6.84 GPIO_KEYSCAN_ROWSENSE5ROUTE - ROWSENSE5 Port/Pin Select

Offset	Bit Position																															
0x540	31	30	29	28	27	26	25	24	23	22	21	20	19	18	17	16	15	14	13	12	11	10	9	8	7	6	5	4	3	2	1	0
Reset													0x0																0x0			
Access													RW																RW			
Name													PIN																PORT			

Bit	Name	Reset	Access	Description
31:20	Reserved	To ensure compatibility with future devices, always write Reserved bits to their reset value, unless otherwise stated. More information in 1.2 Conventions		
19:16	PIN ROWSENSE5 pin select register	0x0	RW	ROWSENSE5 pin select register
15:2	Reserved	To ensure compatibility with future devices, always write Reserved bits to their reset value, unless otherwise stated. More information in 1.2 Conventions		
1:0	PORT ROWSENSE5 port select register	0x0	RW	ROWSENSE5 port select register

24.6.85 GPIO_LETIMER_ROUTEEN - LETIMER Pin Enable

Offset	Bit Position																															
0x548	31	30	29	28	27	26	25	24	23	22	21	20	19	18	17	16	15	14	13	12	11	10	9	8	7	6	5	4	3	2	1	0
Reset																													0x0	0x0		
Access																													RW	RW		
Name																													OUT1PEN	OUT0PEN		

Bit	Name	Reset	Access	Description
31:2	<i>Reserved</i>	<i>To ensure compatibility with future devices, always write Reserved bits to their reset value, unless otherwise stated. More information in 1.2 Conventions</i>		
1	OUT1PEN OUT1 pin enable control bit	0x0	RW	OUT1 pin enable control bit
0	OUT0PEN OUT0 pin enable control bit	0x0	RW	OUT0 pin enable control bit

24.6.86 GPIO_LETIMER_OUT0ROUTE - OUT0 Port/Pin Select

Offset	Bit Position																															
0x54C	31	30	29	28	27	26	25	24	23	22	21	20	19	18	17	16	15	14	13	12	11	10	9	8	7	6	5	4	3	2	1	0
Reset																	0x0											0x0				
Access																	RW											RW				
Name																	PIN											PORT				

Bit	Name	Reset	Access	Description
31:20	<i>Reserved</i>	<i>To ensure compatibility with future devices, always write Reserved bits to their reset value, unless otherwise stated. More information in 1.2 Conventions</i>		
19:16	PIN OUT0 pin select register	0x0	RW	OUT0 pin select register
15:2	<i>Reserved</i>	<i>To ensure compatibility with future devices, always write Reserved bits to their reset value, unless otherwise stated. More information in 1.2 Conventions</i>		
1:0	PORT OUT0 port select register	0x0	RW	OUT0 port select register

24.6.87 GPIO_LETIMER_OUT1ROUTE - OUT1 Port/Pin Select

Offset	Bit Position																															
0x550	31	30	29	28	27	26	25	24	23	22	21	20	19	18	17	16	15	14	13	12	11	10	9	8	7	6	5	4	3	2	1	0
Reset													0x0																0x0			
Access													RW																RW			
Name													PIN																PORT			

Bit	Name	Reset	Access	Description
31:20	Reserved	<i>To ensure compatibility with future devices, always write Reserved bits to their reset value, unless otherwise stated. More information in 1.2 Conventions</i>		
19:16	PIN OUT1 pin select register	0x0	RW	OUT1 pin select register
15:2	Reserved	<i>To ensure compatibility with future devices, always write Reserved bits to their reset value, unless otherwise stated. More information in 1.2 Conventions</i>		
1:0	PORT OUT1 port select register	0x0	RW	OUT1 port select register

24.6.88 GPIO_MODEM_ROUTEEN - MODEM Pin Enable

Offset	Bit Position																																																	
0x558	31	30	29	28	27	26	25	24	23	22	21	20	19	18	17	16	15	14	13	12	11	10	9	8	7	6	5	4	3	2	1	0																		
Reset																		0x0	0x0	0x0	0x0	0x0	0x0	0x0	0x0	0x0	0x0	0x0	0x0	0x0	0x0	0x0	0x0	0x0	0x0	0x0	0x0	0x0	0x0	0x0	0x0	0x0	0x0	0x0	0x0	0x0	0x0	0x0		
Access																		RW	RW	RW	RW	RW	RW	RW	RW	RW	RW	RW	RW	RW	RW	RW	RW	RW	RW	RW	RW	RW	RW	RW	RW	RW	RW	RW	RW	RW	RW	RW	RW	
Name																		DOUTPEN	DCLKPEN	ANTRRIGSTOPPEN	ANTRRIGPEN	ANTSWUSPEN	ANTSWENPEN	ANTRR5PEN	ANTRR4PEN	ANTRR3PEN	ANTRR2PEN	ANTRR1PEN	ANTRR0PEN	ANTRR0PEN	ANTRR0PEN	ANTRR0PEN	ANTRR0PEN	ANTRR0PEN	ANTRR0PEN	ANTRR0PEN	ANTRR0PEN	ANTRR0PEN	ANTRR0PEN	ANTRR0PEN	ANTRR0PEN	ANTRR0PEN	ANTRR0PEN	ANTRR0PEN	ANTRR0PEN	ANTRR0PEN	ANTRR0PEN	ANTRR0PEN	ANTRR0PEN	ANTRR0PEN

Bit	Name	Reset	Access	Description
31:15	<i>Reserved</i>	<i>To ensure compatibility with future devices, always write Reserved bits to their reset value, unless otherwise stated. More information in 1.2 Conventions</i>		
14	DOUTPEN DOUT pin enable control bit	0x0	RW	DOUT pin enable control bit
13	DCLKPEN DCLK pin enable control bit	0x0	RW	DCLK pin enable control bit
12	ANTRRIGSTOPPEN ANTRRIGSTOP pin enable control bit	0x0	RW	ANTRRIGSTOP pin enable control bit
11	ANTRRIGPEN ANTRRIG pin enable control bit	0x0	RW	ANTRRIG pin enable control bit
10	ANTSWUSPEN ANTSWUS pin enable control bit	0x0	RW	ANTSWUS pin enable control bit
9	ANTSWENPEN ANTSWEN pin enable control bit	0x0	RW	ANTSWEN pin enable control bit
8	ANTRR5PEN ANTRR5 pin enable control bit	0x0	RW	ANTRR5 pin enable control bit
7	ANTRR4PEN ANTRR4 pin enable control bit	0x0	RW	ANTRR4 pin enable control bit
6	ANTRR3PEN ANTRR3 pin enable control bit	0x0	RW	ANTRR3 pin enable control bit
5	ANTRR2PEN ANTRR2 pin enable control bit	0x0	RW	ANTRR2 pin enable control bit
4	ANTRR1PEN ANTRR1 pin enable control bit	0x0	RW	ANTRR1 pin enable control bit
3	ANTRR0PEN ANTRR0 pin enable control bit	0x0	RW	ANTRR0 pin enable control bit

Bit	Name	Reset	Access	Description
2	ANTROLLOVERPEN	0x0	RW	ANTROLLOVER pin enable control bit ANTROLLOVER pin enable control bit
1	ANT1PEN	0x0	RW	ANT1 pin enable control bit ANT1 pin enable control bit
0	ANT0PEN	0x0	RW	ANT0 pin enable control bit ANT0 pin enable control bit

24.6.89 GPIO_MODEM_ANT0ROUTE - ANT0 Port/Pin Select

Offset	Bit Position																															
0x55C	31	30	29	28	27	26	25	24	23	22	21	20	19	18	17	16	15	14	13	12	11	10	9	8	7	6	5	4	3	2	1	0
Reset													0x0																0x0			
Access													RW																RW			
Name													PIN																PORT			

Bit	Name	Reset	Access	Description
31:20	<i>Reserved</i>	<i>To ensure compatibility with future devices, always write Reserved bits to their reset value, unless otherwise stated. More information in 1.2 Conventions</i>		
19:16	PIN	0x0	RW	ANT0 pin select register ANT0 pin select register
15:2	<i>Reserved</i>	<i>To ensure compatibility with future devices, always write Reserved bits to their reset value, unless otherwise stated. More information in 1.2 Conventions</i>		
1:0	PORT	0x0	RW	ANT0 port select register ANT0 port select register

24.6.90 GPIO_MODEM_ANT1ROUTE - ANT1 Port/Pin Select

Offset	Bit Position																															
0x560	31	30	29	28	27	26	25	24	23	22	21	20	19	18	17	16	15	14	13	12	11	10	9	8	7	6	5	4	3	2	1	0
Reset													0x0																0x0			
Access													RW																RW			
Name													PIN																PORT			

Bit	Name	Reset	Access	Description
31:20	Reserved	To ensure compatibility with future devices, always write Reserved bits to their reset value, unless otherwise stated. More information in 1.2 Conventions		
19:16	PIN ANT1 pin select register	0x0	RW	ANT1 pin select register
15:2	Reserved	To ensure compatibility with future devices, always write Reserved bits to their reset value, unless otherwise stated. More information in 1.2 Conventions		
1:0	PORT ANT1 port select register	0x0	RW	ANT1 port select register

24.6.91 GPIO_MODEM_ANTROLLOVERROUTE - ANTROLLOVER Port/Pin Select

Offset	Bit Position																															
0x564	31	30	29	28	27	26	25	24	23	22	21	20	19	18	17	16	15	14	13	12	11	10	9	8	7	6	5	4	3	2	1	0
Reset													0x0																0x0			
Access													RW																RW			
Name													PIN																PORT			

Bit	Name	Reset	Access	Description
31:20	Reserved	To ensure compatibility with future devices, always write Reserved bits to their reset value, unless otherwise stated. More information in 1.2 Conventions		
19:16	PIN ANTROLLOVER pin select register	0x0	RW	ANTROLLOVER pin select register
15:2	Reserved	To ensure compatibility with future devices, always write Reserved bits to their reset value, unless otherwise stated. More information in 1.2 Conventions		
1:0	PORT ANTROLLOVER port select register	0x0	RW	ANTROLLOVER port select register

24.6.92 GPIO_MODEM_ANTRR0ROUTE - ANTRR0 Port/Pin Select

Offset	Bit Position																															
0x568	31	30	29	28	27	26	25	24	23	22	21	20	19	18	17	16	15	14	13	12	11	10	9	8	7	6	5	4	3	2	1	0
Reset														0x0																0x0		
Access														RW																RW		
Name														PIN																PORT		

Bit	Name	Reset	Access	Description
31:20	Reserved			To ensure compatibility with future devices, always write Reserved bits to their reset value, unless otherwise stated. More information in 1.2 Conventions
19:16	PIN	0x0	RW	ANTRR0 pin select register ANTRR0 pin select register
15:2	Reserved			To ensure compatibility with future devices, always write Reserved bits to their reset value, unless otherwise stated. More information in 1.2 Conventions
1:0	PORT	0x0	RW	ANTRR0 port select register ANTRR0 port select register

24.6.93 GPIO_MODEM_ANTRR1ROUTE - ANTRR1 Port/Pin Select

Offset	Bit Position																															
0x56C	31	30	29	28	27	26	25	24	23	22	21	20	19	18	17	16	15	14	13	12	11	10	9	8	7	6	5	4	3	2	1	0
Reset														0x0																0x0		
Access														RW																RW		
Name														PIN																PORT		

Bit	Name	Reset	Access	Description
31:20	Reserved			To ensure compatibility with future devices, always write Reserved bits to their reset value, unless otherwise stated. More information in 1.2 Conventions
19:16	PIN	0x0	RW	ANTRR1 pin select register ANTRR1 pin select register
15:2	Reserved			To ensure compatibility with future devices, always write Reserved bits to their reset value, unless otherwise stated. More information in 1.2 Conventions
1:0	PORT	0x0	RW	ANTRR1 port select register ANTRR1 port select register

24.6.94 GPIO_MODEM_ANTRR2ROUTE - ANTRR2 Port/Pin Select

Offset	Bit Position																															
0x570	31	30	29	28	27	26	25	24	23	22	21	20	19	18	17	16	15	14	13	12	11	10	9	8	7	6	5	4	3	2	1	0
Reset														0x0																0x0		
Access														RW																RW		
Name														PIN																PORT		

Bit	Name	Reset	Access	Description
31:20	Reserved			To ensure compatibility with future devices, always write Reserved bits to their reset value, unless otherwise stated. More information in 1.2 Conventions
19:16	PIN	0x0	RW	ANTRR2 pin select register ANTRR2 pin select register
15:2	Reserved			To ensure compatibility with future devices, always write Reserved bits to their reset value, unless otherwise stated. More information in 1.2 Conventions
1:0	PORT	0x0	RW	ANTRR2 port select register ANTRR2 port select register

24.6.95 GPIO_MODEM_ANTRR3ROUTE - ANTRR3 Port/Pin Select

Offset	Bit Position																															
0x574	31	30	29	28	27	26	25	24	23	22	21	20	19	18	17	16	15	14	13	12	11	10	9	8	7	6	5	4	3	2	1	0
Reset														0x0																0x0		
Access														RW																RW		
Name														PIN																PORT		

Bit	Name	Reset	Access	Description
31:20	Reserved			To ensure compatibility with future devices, always write Reserved bits to their reset value, unless otherwise stated. More information in 1.2 Conventions
19:16	PIN	0x0	RW	ANTRR3 pin select register ANTRR3 pin select register
15:2	Reserved			To ensure compatibility with future devices, always write Reserved bits to their reset value, unless otherwise stated. More information in 1.2 Conventions
1:0	PORT	0x0	RW	ANTRR3 port select register ANTRR3 port select register

24.6.96 GPIO_MODEM_ANTRR4ROUTE - ANTRR4 Port/Pin Select

Offset	Bit Position																															
0x578	31	30	29	28	27	26	25	24	23	22	21	20	19	18	17	16	15	14	13	12	11	10	9	8	7	6	5	4	3	2	1	0
Reset													0x0																0x0			
Access													RW																RW			
Name													PIN																PORT			

Bit	Name	Reset	Access	Description
31:20	Reserved			To ensure compatibility with future devices, always write Reserved bits to their reset value, unless otherwise stated. More information in 1.2 Conventions
19:16	PIN	0x0	RW	ANTRR4 pin select register ANTRR4 pin select register
15:2	Reserved			To ensure compatibility with future devices, always write Reserved bits to their reset value, unless otherwise stated. More information in 1.2 Conventions
1:0	PORT	0x0	RW	ANTRR4 port select register ANTRR4 port select register

24.6.97 GPIO_MODEM_ANTRR5ROUTE - ANTRR5 Port/Pin Select

Offset	Bit Position																															
0x57C	31	30	29	28	27	26	25	24	23	22	21	20	19	18	17	16	15	14	13	12	11	10	9	8	7	6	5	4	3	2	1	0
Reset													0x0																0x0			
Access													RW																RW			
Name													PIN																PORT			

Bit	Name	Reset	Access	Description
31:20	Reserved			To ensure compatibility with future devices, always write Reserved bits to their reset value, unless otherwise stated. More information in 1.2 Conventions
19:16	PIN	0x0	RW	ANTRR5 pin select register ANTRR5 pin select register
15:2	Reserved			To ensure compatibility with future devices, always write Reserved bits to their reset value, unless otherwise stated. More information in 1.2 Conventions
1:0	PORT	0x0	RW	ANTRR5 port select register ANTRR5 port select register

24.6.98 GPIO_MODEM_ANTSWENROUTE - ANTSWEN Port/Pin Select

Offset	Bit Position																															
0x580	31	30	29	28	27	26	25	24	23	22	21	20	19	18	17	16	15	14	13	12	11	10	9	8	7	6	5	4	3	2	1	0
Reset														0x0																0x0		
Access														RW																RW		
Name														PIN																PORT		

Bit	Name	Reset	Access	Description
31:20	Reserved	To ensure compatibility with future devices, always write Reserved bits to their reset value, unless otherwise stated. More information in 1.2 Conventions		
19:16	PIN	0x0	RW	ANTSWEN pin select register ANTSWEN pin select register
15:2	Reserved	To ensure compatibility with future devices, always write Reserved bits to their reset value, unless otherwise stated. More information in 1.2 Conventions		
1:0	PORT	0x0	RW	ANTSWEN port select register ANTSWEN port select register

24.6.99 GPIO_MODEM_ANTSWUSROUTE - ANTSWUS Port/Pin Select

Offset	Bit Position																															
0x584	31	30	29	28	27	26	25	24	23	22	21	20	19	18	17	16	15	14	13	12	11	10	9	8	7	6	5	4	3	2	1	0
Reset														0x0																0x0		
Access														RW																RW		
Name														PIN																PORT		

Bit	Name	Reset	Access	Description
31:20	Reserved	To ensure compatibility with future devices, always write Reserved bits to their reset value, unless otherwise stated. More information in 1.2 Conventions		
19:16	PIN	0x0	RW	ANTSWUS pin select register ANTSWUS pin select register
15:2	Reserved	To ensure compatibility with future devices, always write Reserved bits to their reset value, unless otherwise stated. More information in 1.2 Conventions		
1:0	PORT	0x0	RW	ANTSWUS port select register ANTSWUS port select register

24.6.100 GPIO_MODEM_ANTTRIGROUTE - ANTTRIG Port/Pin Select

Offset	Bit Position																																
0x588	31	30	29	28	27	26	25	24	23	22	21	20	19	18	17	16	15	14	13	12	11	10	9	8	7	6	5	4	3	2	1	0	
Reset														0x0																		0x0	
Access														RW																		RW	
Name														PIN																		PORT	

Bit	Name	Reset	Access	Description
31:20	Reserved	<i>To ensure compatibility with future devices, always write Reserved bits to their reset value, unless otherwise stated. More information in 1.2 Conventions</i>		
19:16	PIN	0x0	RW	ANTTRIG pin select register ANTTRIG pin select register
15:2	Reserved	<i>To ensure compatibility with future devices, always write Reserved bits to their reset value, unless otherwise stated. More information in 1.2 Conventions</i>		
1:0	PORT	0x0	RW	ANTTRIG port select register ANTTRIG port select register

24.6.101 GPIO_MODEM_ANTTRIGSTOPROUTE - ANTTRIGSTOP Port/Pin Select

Offset	Bit Position																																
0x58C	31	30	29	28	27	26	25	24	23	22	21	20	19	18	17	16	15	14	13	12	11	10	9	8	7	6	5	4	3	2	1	0	
Reset														0x0																		0x0	
Access														RW																		RW	
Name														PIN																		PORT	

Bit	Name	Reset	Access	Description
31:20	Reserved	<i>To ensure compatibility with future devices, always write Reserved bits to their reset value, unless otherwise stated. More information in 1.2 Conventions</i>		
19:16	PIN	0x0	RW	ANTTRIGSTOP pin select register ANTTRIGSTOP pin select register
15:2	Reserved	<i>To ensure compatibility with future devices, always write Reserved bits to their reset value, unless otherwise stated. More information in 1.2 Conventions</i>		
1:0	PORT	0x0	RW	ANTTRIGSTOP port select register ANTTRIGSTOP port select register

24.6.102 GPIO_MODEM_DCLKROUTE - DCLK Port/Pin Select

Offset	Bit Position																															
0x590	31	30	29	28	27	26	25	24	23	22	21	20	19	18	17	16	15	14	13	12	11	10	9	8	7	6	5	4	3	2	1	0
Reset													0x0																0x0			
Access													RW																RW			
Name													PIN																PORT			

Bit	Name	Reset	Access	Description
31:20	Reserved	To ensure compatibility with future devices, always write Reserved bits to their reset value, unless otherwise stated. More information in 1.2 Conventions		
19:16	PIN DCLK pin select register	0x0	RW	DCLK pin select register
15:2	Reserved	To ensure compatibility with future devices, always write Reserved bits to their reset value, unless otherwise stated. More information in 1.2 Conventions		
1:0	PORT DCLK port select register	0x0	RW	DCLK port select register

24.6.103 GPIO_MODEM_DINROUTE - DIN Port/Pin Select

Offset	Bit Position																															
0x594	31	30	29	28	27	26	25	24	23	22	21	20	19	18	17	16	15	14	13	12	11	10	9	8	7	6	5	4	3	2	1	0
Reset													0x0																0x0			
Access													RW																RW			
Name													PIN																PORT			

Bit	Name	Reset	Access	Description
31:20	Reserved	To ensure compatibility with future devices, always write Reserved bits to their reset value, unless otherwise stated. More information in 1.2 Conventions		
19:16	PIN DIN pin select register	0x0	RW	DIN pin select register
15:2	Reserved	To ensure compatibility with future devices, always write Reserved bits to their reset value, unless otherwise stated. More information in 1.2 Conventions		
1:0	PORT DIN port select register	0x0	RW	DIN port select register

24.6.104 GPIO_MODEM_DOUTROUTE - DOUT Port/Pin Select

Offset	Bit Position																															
0x598	31	30	29	28	27	26	25	24	23	22	21	20	19	18	17	16	15	14	13	12	11	10	9	8	7	6	5	4	3	2	1	0
Reset													0x0																0x0			
Access													RW																RW			
Name													PIN																PORT			

Bit	Name	Reset	Access	Description
31:20	Reserved	<i>To ensure compatibility with future devices, always write Reserved bits to their reset value, unless otherwise stated. More information in 1.2 Conventions</i>		
19:16	PIN DOUT pin select register	0x0	RW	DOUT pin select register
15:2	Reserved	<i>To ensure compatibility with future devices, always write Reserved bits to their reset value, unless otherwise stated. More information in 1.2 Conventions</i>		
1:0	PORT DOUT port select register	0x0	RW	DOUT port select register

24.6.105 GPIO_PCNT0_S0INROUTE - S0IN Port/Pin Select

Offset	Bit Position																															
0x5A4	31	30	29	28	27	26	25	24	23	22	21	20	19	18	17	16	15	14	13	12	11	10	9	8	7	6	5	4	3	2	1	0
Reset													0x0																0x0			
Access													RW																RW			
Name													PIN																PORT			

Bit	Name	Reset	Access	Description
31:20	Reserved	<i>To ensure compatibility with future devices, always write Reserved bits to their reset value, unless otherwise stated. More information in 1.2 Conventions</i>		
19:16	PIN S0IN pin select register	0x0	RW	S0IN pin select register
15:2	Reserved	<i>To ensure compatibility with future devices, always write Reserved bits to their reset value, unless otherwise stated. More information in 1.2 Conventions</i>		
1:0	PORT S0IN port select register	0x0	RW	S0IN port select register

24.6.106 GPIO_PCNT0_S1INROUTE - S1IN Port/Pin Select

Offset	Bit Position																															
0x5A8	31	30	29	28	27	26	25	24	23	22	21	20	19	18	17	16	15	14	13	12	11	10	9	8	7	6	5	4	3	2	1	0
Reset													0x0																0x0			
Access													RW																RW			
Name													PIN																PORT			

Bit	Name	Reset	Access	Description
31:20	Reserved	<i>To ensure compatibility with future devices, always write Reserved bits to their reset value, unless otherwise stated. More information in 1.2 Conventions</i>		
19:16	PIN S1IN pin select register	0x0	RW	S1IN pin select register
15:2	Reserved	<i>To ensure compatibility with future devices, always write Reserved bits to their reset value, unless otherwise stated. More information in 1.2 Conventions</i>		
1:0	PORT S1IN port select register	0x0	RW	S1IN port select register

24.6.107 GPIO_PRSD0_ROUTEEN - PRSD0 Pin Enable

Offset	Bit Position																																															
0x5B0	31	30	29	28	27	26	25	24	23	22	21	20	19	18	17	16	15	14	13	12	11	10	9	8	7	6	5	4	3	2	1	0																
Reset													0x0	0x0	0x0	0x0	0x0	0x0	0x0	0x0	0x0	0x0	0x0	0x0	0x0	0x0	0x0	0x0	0x0	0x0	0x0	0x0	0x0	0x0	0x0	0x0	0x0	0x0	0x0	0x0	0x0	0x0	0x0	0x0				
Access													RW	RW	RW	RW	RW	RW	RW	RW	RW	RW	RW	RW	RW	RW	RW	RW	RW	RW	RW	RW	RW	RW	RW	RW	RW	RW	RW	RW	RW	RW	RW	RW	RW			
Name													SYNCH3PEN	SYNCH2PEN	SYNCH1PEN	SYNCH0PEN	ASYNCH15PEN	ASYNCH14PEN	ASYNCH13PEN	ASYNCH12PEN	ASYNCH11PEN	ASYNCH10PEN	ASYNCH9PEN	ASYNCH8PEN	ASYNCH7PEN	ASYNCH6PEN	ASYNCH5PEN	ASYNCH4PEN	ASYNCH3PEN	ASYNCH2PEN	ASYNCH1PEN	ASYNCH0PEN																

Bit	Name	Reset	Access	Description
31:20	Reserved	To ensure compatibility with future devices, always write Reserved bits to their reset value, unless otherwise stated. More information in 1.2 Conventions		
19	SYNCH3PEN SYNCH3 pin enable control bit	0x0	RW	SYNCH3 pin enable control bit
18	SYNCH2PEN SYNCH2 pin enable control bit	0x0	RW	SYNCH2 pin enable control bit
17	SYNCH1PEN SYNCH1 pin enable control bit	0x0	RW	SYNCH1 pin enable control bit
16	SYNCH0PEN SYNCH0 pin enable control bit	0x0	RW	SYNCH0 pin enable control bit
15	ASYNCH15PEN ASYNCH15 pin enable control bit	0x0	RW	ASYNCH15 pin enable control bit
14	ASYNCH14PEN ASYNCH14 pin enable control bit	0x0	RW	ASYNCH14 pin enable control bit
13	ASYNCH13PEN ASYNCH13 pin enable control bit	0x0	RW	ASYNCH13 pin enable control bit
12	ASYNCH12PEN ASYNCH12 pin enable control bit	0x0	RW	ASYNCH12 pin enable control bit
11	ASYNCH11PEN ASYNCH11 pin enable control bit	0x0	RW	ASYNCH11 pin enable control bit
10	ASYNCH10PEN ASYNCH10 pin enable control bit	0x0	RW	ASYNCH10 pin enable control bit
9	ASYNCH9PEN ASYNCH9 pin enable control bit	0x0	RW	ASYNCH9 pin enable control bit
8	ASYNCH8PEN ASYNCH8 pin enable control bit	0x0	RW	ASYNCH8 pin enable control bit
7	ASYNCH7PEN	0x0	RW	ASYNCH7 pin enable control bit

Bit	Name	Reset	Access	Description
				ASYNCH7 pin enable control bit
6	ASYNCH6PEN	0x0	RW	ASYNCH6 pin enable control bit ASYNCH6 pin enable control bit
5	ASYNCH5PEN	0x0	RW	ASYNCH5 pin enable control bit ASYNCH5 pin enable control bit
4	ASYNCH4PEN	0x0	RW	ASYNCH4 pin enable control bit ASYNCH4 pin enable control bit
3	ASYNCH3PEN	0x0	RW	ASYNCH3 pin enable control bit ASYNCH3 pin enable control bit
2	ASYNCH2PEN	0x0	RW	ASYNCH2 pin enable control bit ASYNCH2 pin enable control bit
1	ASYNCH1PEN	0x0	RW	ASYNCH1 pin enable control bit ASYNCH1 pin enable control bit
0	ASYNCH0PEN	0x0	RW	ASYNCH0 pin enable control bit ASYNCH0 pin enable control bit

24.6.108 GPIO_PRSD0_ASYNCH0ROUTE - ASYNCH0 Port/Pin Select

Offset	Bit Position																															
0x5B4	31	30	29	28	27	26	25	24	23	22	21	20	19	18	17	16	15	14	13	12	11	10	9	8	7	6	5	4	3	2	1	0
Reset														0x0													0x0					
Access														RW													RW					
Name														PIN													PORT					

Bit	Name	Reset	Access	Description
31:20	Reserved			To ensure compatibility with future devices, always write Reserved bits to their reset value, unless otherwise stated. More information in 1.2 Conventions
19:16	PIN	0x0	RW	ASYNCH0 pin select register ASYNCH0 pin select register
15:2	Reserved			To ensure compatibility with future devices, always write Reserved bits to their reset value, unless otherwise stated. More information in 1.2 Conventions
1:0	PORT	0x0	RW	ASYNCH0 port select register ASYNCH0 port select register

24.6.109 GPIO_PRS0_ASYNCH1ROUTE - ASYNCH1 Port/Pin Select

Offset	Bit Position																															
0x5B8	31	30	29	28	27	26	25	24	23	22	21	20	19	18	17	16	15	14	13	12	11	10	9	8	7	6	5	4	3	2	1	0
Reset													0x0																0x0			
Access													RW																RW			
Name													PIN																PORT			

Bit	Name	Reset	Access	Description
31:20	Reserved	To ensure compatibility with future devices, always write Reserved bits to their reset value, unless otherwise stated. More information in 1.2 Conventions		
19:16	PIN	0x0	RW	ASYNCH1 pin select register ASYNCH1 pin select register
15:2	Reserved	To ensure compatibility with future devices, always write Reserved bits to their reset value, unless otherwise stated. More information in 1.2 Conventions		
1:0	PORT	0x0	RW	ASYNCH1 port select register ASYNCH1 port select register

24.6.110 GPIO_PRS0_ASYNCH2ROUTE - ASYNCH2 Port/Pin Select

Offset	Bit Position																															
0x5BC	31	30	29	28	27	26	25	24	23	22	21	20	19	18	17	16	15	14	13	12	11	10	9	8	7	6	5	4	3	2	1	0
Reset													0x0																0x0			
Access													RW																RW			
Name													PIN																PORT			

Bit	Name	Reset	Access	Description
31:20	Reserved	To ensure compatibility with future devices, always write Reserved bits to their reset value, unless otherwise stated. More information in 1.2 Conventions		
19:16	PIN	0x0	RW	ASYNCH2 pin select register ASYNCH2 pin select register
15:2	Reserved	To ensure compatibility with future devices, always write Reserved bits to their reset value, unless otherwise stated. More information in 1.2 Conventions		
1:0	PORT	0x0	RW	ASYNCH2 port select register ASYNCH2 port select register

24.6.111 GPIO_PRS0_ASYNCH3ROUTE - ASYNCH3 Port/Pin Select

Offset	Bit Position																															
0x5C0	31	30	29	28	27	26	25	24	23	22	21	20	19	18	17	16	15	14	13	12	11	10	9	8	7	6	5	4	3	2	1	0
Reset													0x0																0x0			
Access													RW																RW			
Name													PIN																PORT			

Bit	Name	Reset	Access	Description
31:20	Reserved	<i>To ensure compatibility with future devices, always write Reserved bits to their reset value, unless otherwise stated. More information in 1.2 Conventions</i>		
19:16	PIN	0x0	RW	ASYNCH3 pin select register ASYNCH3 pin select register
15:2	Reserved	<i>To ensure compatibility with future devices, always write Reserved bits to their reset value, unless otherwise stated. More information in 1.2 Conventions</i>		
1:0	PORT	0x0	RW	ASYNCH3 port select register ASYNCH3 port select register

24.6.112 GPIO_PRS0_ASYNCH4ROUTE - ASYNCH4 Port/Pin Select

Offset	Bit Position																															
0x5C4	31	30	29	28	27	26	25	24	23	22	21	20	19	18	17	16	15	14	13	12	11	10	9	8	7	6	5	4	3	2	1	0
Reset													0x0																0x0			
Access													RW																RW			
Name													PIN																PORT			

Bit	Name	Reset	Access	Description
31:20	Reserved	<i>To ensure compatibility with future devices, always write Reserved bits to their reset value, unless otherwise stated. More information in 1.2 Conventions</i>		
19:16	PIN	0x0	RW	ASYNCH4 pin select register ASYNCH4 pin select register
15:2	Reserved	<i>To ensure compatibility with future devices, always write Reserved bits to their reset value, unless otherwise stated. More information in 1.2 Conventions</i>		
1:0	PORT	0x0	RW	ASYNCH4 port select register ASYNCH4 port select register

24.6.113 GPIO_PRS0_ASYNCH5ROUTE - ASYNCH5 Port/Pin Select

Offset	Bit Position																															
0x5C8	31	30	29	28	27	26	25	24	23	22	21	20	19	18	17	16	15	14	13	12	11	10	9	8	7	6	5	4	3	2	1	0
Reset													0x0																0x0			
Access													RW																RW			
Name													PIN																PORT			

Bit	Name	Reset	Access	Description
31:20	Reserved	To ensure compatibility with future devices, always write Reserved bits to their reset value, unless otherwise stated. More information in 1.2 Conventions		
19:16	PIN	0x0	RW	ASYNCH5 pin select register ASYNCH5 pin select register
15:2	Reserved	To ensure compatibility with future devices, always write Reserved bits to their reset value, unless otherwise stated. More information in 1.2 Conventions		
1:0	PORT	0x0	RW	ASYNCH5 port select register ASYNCH5 port select register

24.6.114 GPIO_PRS0_ASYNCH6ROUTE - ASYNCH6 Port/Pin Select

Offset	Bit Position																															
0x5CC	31	30	29	28	27	26	25	24	23	22	21	20	19	18	17	16	15	14	13	12	11	10	9	8	7	6	5	4	3	2	1	0
Reset													0x0																0x0			
Access													RW																RW			
Name													PIN																PORT			

Bit	Name	Reset	Access	Description
31:20	Reserved	To ensure compatibility with future devices, always write Reserved bits to their reset value, unless otherwise stated. More information in 1.2 Conventions		
19:16	PIN	0x0	RW	ASYNCH6 pin select register ASYNCH6 pin select register
15:2	Reserved	To ensure compatibility with future devices, always write Reserved bits to their reset value, unless otherwise stated. More information in 1.2 Conventions		
1:0	PORT	0x0	RW	ASYNCH6 port select register ASYNCH6 port select register

24.6.115 GPIO_PRS0_ASYNCH7ROUTE - ASYNCH7 Port/Pin Select

Offset	Bit Position																															
0x5D0	31	30	29	28	27	26	25	24	23	22	21	20	19	18	17	16	15	14	13	12	11	10	9	8	7	6	5	4	3	2	1	0
Reset													0x0																0x0			
Access													RW																RW			
Name													PIN																PORT			

Bit	Name	Reset	Access	Description
31:20	Reserved	To ensure compatibility with future devices, always write Reserved bits to their reset value, unless otherwise stated. More information in 1.2 Conventions		
19:16	PIN	0x0	RW	ASYNCH7 pin select register ASYNCH7 pin select register
15:2	Reserved	To ensure compatibility with future devices, always write Reserved bits to their reset value, unless otherwise stated. More information in 1.2 Conventions		
1:0	PORT	0x0	RW	ASYNCH7 port select register ASYNCH7 port select register

24.6.116 GPIO_PRS0_ASYNCH8ROUTE - ASYNCH8 Port/Pin Select

Offset	Bit Position																															
0x5D4	31	30	29	28	27	26	25	24	23	22	21	20	19	18	17	16	15	14	13	12	11	10	9	8	7	6	5	4	3	2	1	0
Reset													0x0																0x0			
Access													RW																RW			
Name													PIN																PORT			

Bit	Name	Reset	Access	Description
31:20	Reserved	To ensure compatibility with future devices, always write Reserved bits to their reset value, unless otherwise stated. More information in 1.2 Conventions		
19:16	PIN	0x0	RW	ASYNCH8 pin select register ASYNCH8 pin select register
15:2	Reserved	To ensure compatibility with future devices, always write Reserved bits to their reset value, unless otherwise stated. More information in 1.2 Conventions		
1:0	PORT	0x0	RW	ASYNCH8 port select register ASYNCH8 port select register

24.6.117 GPIO_PRS0_ASYNCH9ROUTE - ASYNCH9 Port/Pin Select

Offset	Bit Position																															
0x5D8	31	30	29	28	27	26	25	24	23	22	21	20	19	18	17	16	15	14	13	12	11	10	9	8	7	6	5	4	3	2	1	0
Reset													0x0																0x0			
Access													RW																RW			
Name													PIN																PORT			

Bit	Name	Reset	Access	Description
31:20	Reserved	To ensure compatibility with future devices, always write Reserved bits to their reset value, unless otherwise stated. More information in 1.2 Conventions		
19:16	PIN	0x0	RW	ASYNCH9 pin select register ASYNCH9 pin select register
15:2	Reserved	To ensure compatibility with future devices, always write Reserved bits to their reset value, unless otherwise stated. More information in 1.2 Conventions		
1:0	PORT	0x0	RW	ASYNCH9 port select register ASYNCH9 port select register

24.6.118 GPIO_PRS0_ASYNCH10ROUTE - ASYNCH10 Port/Pin Select

Offset	Bit Position																															
0x5DC	31	30	29	28	27	26	25	24	23	22	21	20	19	18	17	16	15	14	13	12	11	10	9	8	7	6	5	4	3	2	1	0
Reset													0x0																0x0			
Access													RW																RW			
Name													PIN																PORT			

Bit	Name	Reset	Access	Description
31:20	Reserved	To ensure compatibility with future devices, always write Reserved bits to their reset value, unless otherwise stated. More information in 1.2 Conventions		
19:16	PIN	0x0	RW	ASYNCH10 pin select register ASYNCH10 pin select register
15:2	Reserved	To ensure compatibility with future devices, always write Reserved bits to their reset value, unless otherwise stated. More information in 1.2 Conventions		
1:0	PORT	0x0	RW	ASYNCH10 port select register ASYNCH10 port select register

24.6.119 GPIO_PRS0_ASYNCH11ROUTE - ASYNCH11 Port/Pin Select

Offset	Bit Position																															
0x5E0	31	30	29	28	27	26	25	24	23	22	21	20	19	18	17	16	15	14	13	12	11	10	9	8	7	6	5	4	3	2	1	0
Reset														0x0																0x0		
Access														RW																RW		
Name														PIN																PORT		

Bit	Name	Reset	Access	Description
31:20	Reserved	To ensure compatibility with future devices, always write Reserved bits to their reset value, unless otherwise stated. More information in 1.2 Conventions		
19:16	PIN	0x0	RW	ASYNCH11 pin select register ASYNCH11 pin select register
15:2	Reserved	To ensure compatibility with future devices, always write Reserved bits to their reset value, unless otherwise stated. More information in 1.2 Conventions		
1:0	PORT	0x0	RW	ASYNCH11 port select register ASYNCH11 port select register

24.6.120 GPIO_PRS0_ASYNCH12ROUTE - ASYNCH12 Port/Pin Select

Offset	Bit Position																															
0x5E4	31	30	29	28	27	26	25	24	23	22	21	20	19	18	17	16	15	14	13	12	11	10	9	8	7	6	5	4	3	2	1	0
Reset														0x0																0x0		
Access														RW																RW		
Name														PIN																PORT		

Bit	Name	Reset	Access	Description
31:20	Reserved	To ensure compatibility with future devices, always write Reserved bits to their reset value, unless otherwise stated. More information in 1.2 Conventions		
19:16	PIN	0x0	RW	ASYNCH12 pin select register ASYNCH12 pin select register
15:2	Reserved	To ensure compatibility with future devices, always write Reserved bits to their reset value, unless otherwise stated. More information in 1.2 Conventions		
1:0	PORT	0x0	RW	ASYNCH12 port select register ASYNCH12 port select register

24.6.121 GPIO_PRS0_ASYNCH13ROUTE - ASYNCH13 Port/Pin Select

Offset	Bit Position																															
0x5E8	31	30	29	28	27	26	25	24	23	22	21	20	19	18	17	16	15	14	13	12	11	10	9	8	7	6	5	4	3	2	1	0
Reset													0x0																0x0			
Access													RW																RW			
Name													PIN																PORT			

Bit	Name	Reset	Access	Description
31:20	Reserved	To ensure compatibility with future devices, always write Reserved bits to their reset value, unless otherwise stated. More information in 1.2 Conventions		
19:16	PIN	0x0	RW	ASYNCH13 pin select register ASYNCH13 pin select register
15:2	Reserved	To ensure compatibility with future devices, always write Reserved bits to their reset value, unless otherwise stated. More information in 1.2 Conventions		
1:0	PORT	0x0	RW	ASYNCH13 port select register ASYNCH13 port select register

24.6.122 GPIO_PRS0_ASYNCH14ROUTE - ASYNCH14 Port/Pin Select

Offset	Bit Position																															
0x5EC	31	30	29	28	27	26	25	24	23	22	21	20	19	18	17	16	15	14	13	12	11	10	9	8	7	6	5	4	3	2	1	0
Reset													0x0																0x0			
Access													RW																RW			
Name													PIN																PORT			

Bit	Name	Reset	Access	Description
31:20	Reserved	To ensure compatibility with future devices, always write Reserved bits to their reset value, unless otherwise stated. More information in 1.2 Conventions		
19:16	PIN	0x0	RW	ASYNCH14 pin select register ASYNCH14 pin select register
15:2	Reserved	To ensure compatibility with future devices, always write Reserved bits to their reset value, unless otherwise stated. More information in 1.2 Conventions		
1:0	PORT	0x0	RW	ASYNCH14 port select register ASYNCH14 port select register

24.6.123 GPIO_PRS0_ASYNCH15ROUTE - ASYNCH15 Port/Pin Select

Offset	Bit Position																															
0x5F0	31	30	29	28	27	26	25	24	23	22	21	20	19	18	17	16	15	14	13	12	11	10	9	8	7	6	5	4	3	2	1	0
Reset													0x0																0x0			
Access													RW																RW			
Name													PIN																PORT			

Bit	Name	Reset	Access	Description
31:20	Reserved	To ensure compatibility with future devices, always write Reserved bits to their reset value, unless otherwise stated. More information in 1.2 Conventions		
19:16	PIN	0x0	RW	ASYNCH15 pin select register ASYNCH15 pin select register
15:2	Reserved	To ensure compatibility with future devices, always write Reserved bits to their reset value, unless otherwise stated. More information in 1.2 Conventions		
1:0	PORT	0x0	RW	ASYNCH15 port select register ASYNCH15 port select register

24.6.124 GPIO_PRS0_SYNCH0ROUTE - SYNCH0 Port/Pin Select

Offset	Bit Position																															
0x5F4	31	30	29	28	27	26	25	24	23	22	21	20	19	18	17	16	15	14	13	12	11	10	9	8	7	6	5	4	3	2	1	0
Reset													0x0																0x0			
Access													RW																RW			
Name													PIN																PORT			

Bit	Name	Reset	Access	Description
31:20	Reserved	To ensure compatibility with future devices, always write Reserved bits to their reset value, unless otherwise stated. More information in 1.2 Conventions		
19:16	PIN	0x0	RW	SYNCH0 pin select register SYNCH0 pin select register
15:2	Reserved	To ensure compatibility with future devices, always write Reserved bits to their reset value, unless otherwise stated. More information in 1.2 Conventions		
1:0	PORT	0x0	RW	SYNCH0 port select register SYNCH0 port select register

24.6.125 GPIO_PRS0_SYNCH1ROUTE - SYNCH1 Port/Pin Select

Offset	Bit Position																															
0x5F8	31	30	29	28	27	26	25	24	23	22	21	20	19	18	17	16	15	14	13	12	11	10	9	8	7	6	5	4	3	2	1	0
Reset													0x0																0x0			
Access													RW																RW			
Name													PIN																PORT			

Bit	Name	Reset	Access	Description
31:20	Reserved	To ensure compatibility with future devices, always write Reserved bits to their reset value, unless otherwise stated. More information in 1.2 Conventions		
19:16	PIN SYNCH1 pin select register	0x0	RW	SYNCH1 pin select register
15:2	Reserved	To ensure compatibility with future devices, always write Reserved bits to their reset value, unless otherwise stated. More information in 1.2 Conventions		
1:0	PORT SYNCH1 port select register	0x0	RW	SYNCH1 port select register

24.6.126 GPIO_PRS0_SYNCH2ROUTE - SYNCH2 Port/Pin Select

Offset	Bit Position																															
0x5FC	31	30	29	28	27	26	25	24	23	22	21	20	19	18	17	16	15	14	13	12	11	10	9	8	7	6	5	4	3	2	1	0
Reset													0x0																0x0			
Access													RW																RW			
Name													PIN																PORT			

Bit	Name	Reset	Access	Description
31:20	Reserved	To ensure compatibility with future devices, always write Reserved bits to their reset value, unless otherwise stated. More information in 1.2 Conventions		
19:16	PIN SYNCH2 pin select register	0x0	RW	SYNCH2 pin select register
15:2	Reserved	To ensure compatibility with future devices, always write Reserved bits to their reset value, unless otherwise stated. More information in 1.2 Conventions		
1:0	PORT SYNCH2 port select register	0x0	RW	SYNCH2 port select register

24.6.127 GPIO_PR0_SYNCH3ROUTE - SYNCH3 Port/Pin Select

Offset	Bit Position																															
0x600	31	30	29	28	27	26	25	24	23	22	21	20	19	18	17	16	15	14	13	12	11	10	9	8	7	6	5	4	3	2	1	0
Reset														0x0												0x0						
Access														RW												RW						
Name														PIN												PORT						

Bit	Name	Reset	Access	Description
31:20	Reserved	To ensure compatibility with future devices, always write Reserved bits to their reset value, unless otherwise stated. More information in 1.2 Conventions		
19:16	PIN SYNCH3 pin select register	0x0	RW	SYNCH3 pin select register
15:2	Reserved	To ensure compatibility with future devices, always write Reserved bits to their reset value, unless otherwise stated. More information in 1.2 Conventions		
1:0	PORT SYNCH3 port select register	0x0	RW	SYNCH3 port select register

24.6.128 GPIO_RAC_ROUTEEN - RAC Pin Enable

Offset	Bit Position																															
0x608	31	30	29	28	27	26	25	24	23	22	21	20	19	18	17	16	15	14	13	12	11	10	9	8	7	6	5	4	3	2	1	0
Reset																											0x0	0x0				
Access																											RW	RW				
Name																											PAENPEN	LNAENPEN				

Bit	Name	Reset	Access	Description
31:2	Reserved	To ensure compatibility with future devices, always write Reserved bits to their reset value, unless otherwise stated. More information in 1.2 Conventions		
1	PAENPEN PAEN pin enable control bit	0x0	RW	PAEN pin enable control bit
0	LNAENPEN LNAEN pin enable control bit	0x0	RW	LNAEN pin enable control bit

24.6.129 GPIO_RAC_LNAENROUTE - LNAEN Port/Pin Select

Offset	Bit Position																															
0x60C	31	30	29	28	27	26	25	24	23	22	21	20	19	18	17	16	15	14	13	12	11	10	9	8	7	6	5	4	3	2	1	0
Reset													0x0																0x0			
Access													RW																RW			
Name													PIN																PORT			

Bit	Name	Reset	Access	Description
31:20	Reserved	<i>To ensure compatibility with future devices, always write Reserved bits to their reset value, unless otherwise stated. More information in 1.2 Conventions</i>		
19:16	PIN LNAEN pin select register	0x0	RW	LNAEN pin select register
15:2	Reserved	<i>To ensure compatibility with future devices, always write Reserved bits to their reset value, unless otherwise stated. More information in 1.2 Conventions</i>		
1:0	PORT LNAEN port select register	0x0	RW	LNAEN port select register

24.6.130 GPIO_RAC_PAENROUTE - PAEN Port/Pin Select

Offset	Bit Position																															
0x610	31	30	29	28	27	26	25	24	23	22	21	20	19	18	17	16	15	14	13	12	11	10	9	8	7	6	5	4	3	2	1	0
Reset													0x0																0x0			
Access													RW																RW			
Name													PIN																PORT			

Bit	Name	Reset	Access	Description
31:20	Reserved	<i>To ensure compatibility with future devices, always write Reserved bits to their reset value, unless otherwise stated. More information in 1.2 Conventions</i>		
19:16	PIN PAEN pin select register	0x0	RW	PAEN pin select register
15:2	Reserved	<i>To ensure compatibility with future devices, always write Reserved bits to their reset value, unless otherwise stated. More information in 1.2 Conventions</i>		
1:0	PORT PAEN port select register	0x0	RW	PAEN port select register

24.6.131 GPIO_SYX00_BUFOUTREQINASYNCROUTE - BUFOUTREQINASYNC Port/Pin Select

Offset	Bit Position																															
0x678	31	30	29	28	27	26	25	24	23	22	21	20	19	18	17	16	15	14	13	12	11	10	9	8	7	6	5	4	3	2	1	0
Reset													0x0																0x0			
Access													RW																RW			
Name													PIN																PORT			

Bit	Name	Reset	Access	Description
31:20	Reserved	<i>To ensure compatibility with future devices, always write Reserved bits to their reset value, unless otherwise stated. More information in 1.2 Conventions</i>		
19:16	PIN	0x0	RW	BUFOUTREQINASYNC pin select register BUFOUTREQINASYNC pin select register
15:2	Reserved	<i>To ensure compatibility with future devices, always write Reserved bits to their reset value, unless otherwise stated. More information in 1.2 Conventions</i>		
1:0	PORT	0x0	RW	BUFOUTREQINASYNC port select register BUFOUTREQINASYNC port select register

24.6.132 GPIO_TIMER0_ROUTEEN - TIMER0 Pin Enable

Offset	Bit Position																															
0x680	31	30	29	28	27	26	25	24	23	22	21	20	19	18	17	16	15	14	13	12	11	10	9	8	7	6	5	4	3	2	1	0
Reset																																
Access																																
Name																																
																											CCC2PEN	CCC1PEN	CCC0PEN	CC2PEN	CC1PEN	CC0PEN

Bit	Name	Reset	Access	Description
31:6	<i>Reserved</i>	<i>To ensure compatibility with future devices, always write Reserved bits to their reset value, unless otherwise stated. More information in 1.2 Conventions</i>		
5	CCC2PEN CDTI2 pin enable control bit	0x0	RW	CDTI2 pin enable control bit
4	CCC1PEN CDTI1 pin enable control bit	0x0	RW	CDTI1 pin enable control bit
3	CCC0PEN CDTI0 pin enable control bit	0x0	RW	CDTI0 pin enable control bit
2	CC2PEN CC2 pin enable control bit	0x0	RW	CC2 pin enable control bit
1	CC1PEN CC1 pin enable control bit	0x0	RW	CC1 pin enable control bit
0	CC0PEN CC0 pin enable control bit	0x0	RW	CC0 pin enable control bit

24.6.133 GPIO_TIMER0_CC0ROUTE - CC0 Port/Pin Select

Offset	Bit Position																															
0x684	31	30	29	28	27	26	25	24	23	22	21	20	19	18	17	16	15	14	13	12	11	10	9	8	7	6	5	4	3	2	1	0
Reset													0x0																0x0			
Access													RW																RW			
Name													PIN																PORT			

Bit	Name	Reset	Access	Description
31:20	Reserved	To ensure compatibility with future devices, always write Reserved bits to their reset value, unless otherwise stated. More information in 1.2 Conventions		
19:16	PIN CC0 pin select register	0x0	RW	CC0 pin select register
15:2	Reserved	To ensure compatibility with future devices, always write Reserved bits to their reset value, unless otherwise stated. More information in 1.2 Conventions		
1:0	PORT CC0 port select register	0x0	RW	CC0 port select register

24.6.134 GPIO_TIMER0_CC1ROUTE - CC1 Port/Pin Select

Offset	Bit Position																															
0x688	31	30	29	28	27	26	25	24	23	22	21	20	19	18	17	16	15	14	13	12	11	10	9	8	7	6	5	4	3	2	1	0
Reset													0x0																0x0			
Access													RW																RW			
Name													PIN																PORT			

Bit	Name	Reset	Access	Description
31:20	Reserved	To ensure compatibility with future devices, always write Reserved bits to their reset value, unless otherwise stated. More information in 1.2 Conventions		
19:16	PIN CC1 pin select register	0x0	RW	CC1 pin select register
15:2	Reserved	To ensure compatibility with future devices, always write Reserved bits to their reset value, unless otherwise stated. More information in 1.2 Conventions		
1:0	PORT CC1 port select register	0x0	RW	CC1 port select register

24.6.135 GPIO_TIMER0_CC2ROUTE - CC2 Port/Pin Select

Offset	Bit Position																															
0x68C	31	30	29	28	27	26	25	24	23	22	21	20	19	18	17	16	15	14	13	12	11	10	9	8	7	6	5	4	3	2	1	0
Reset													0x0												0x0							
Access													RW												RW							
Name													PIN												PORT							

Bit	Name	Reset	Access	Description
31:20	Reserved	<i>To ensure compatibility with future devices, always write Reserved bits to their reset value, unless otherwise stated. More information in 1.2 Conventions</i>		
19:16	PIN CC2 pin select register	0x0	RW	CC2 pin select register
15:2	Reserved	<i>To ensure compatibility with future devices, always write Reserved bits to their reset value, unless otherwise stated. More information in 1.2 Conventions</i>		
1:0	PORT CC2 port select register	0x0	RW	CC2 port select register

24.6.136 GPIO_TIMER0_CDTI0ROUTE - CDTI0 Port/Pin Select

Offset	Bit Position																															
0x690	31	30	29	28	27	26	25	24	23	22	21	20	19	18	17	16	15	14	13	12	11	10	9	8	7	6	5	4	3	2	1	0
Reset													0x0												0x0							
Access													RW												RW							
Name													PIN												PORT							

Bit	Name	Reset	Access	Description
31:20	Reserved	<i>To ensure compatibility with future devices, always write Reserved bits to their reset value, unless otherwise stated. More information in 1.2 Conventions</i>		
19:16	PIN CDTI0 pin select register	0x0	RW	CDTI0 pin select register
15:2	Reserved	<i>To ensure compatibility with future devices, always write Reserved bits to their reset value, unless otherwise stated. More information in 1.2 Conventions</i>		
1:0	PORT CDTI0 port select register	0x0	RW	CDTI0 port select register

24.6.137 GPIO_TIMER0_CDTI1ROUTE - CDTI1 Port/Pin Select

Offset	Bit Position																															
0x694	31	30	29	28	27	26	25	24	23	22	21	20	19	18	17	16	15	14	13	12	11	10	9	8	7	6	5	4	3	2	1	0
Reset													0x0																0x0			
Access													RW																RW			
Name													PIN																PORT			

Bit	Name	Reset	Access	Description
31:20	Reserved	<i>To ensure compatibility with future devices, always write Reserved bits to their reset value, unless otherwise stated. More information in 1.2 Conventions</i>		
19:16	PIN CDTI1 pin select register	0x0	RW	CDTI1 pin select register
15:2	Reserved	<i>To ensure compatibility with future devices, always write Reserved bits to their reset value, unless otherwise stated. More information in 1.2 Conventions</i>		
1:0	PORT CDTI1 port select register	0x0	RW	CDTI1 port select register

24.6.138 GPIO_TIMER0_CDTI2ROUTE - CDTI2 Port/Pin Select

Offset	Bit Position																															
0x698	31	30	29	28	27	26	25	24	23	22	21	20	19	18	17	16	15	14	13	12	11	10	9	8	7	6	5	4	3	2	1	0
Reset													0x0																0x0			
Access													RW																RW			
Name													PIN																PORT			

Bit	Name	Reset	Access	Description
31:20	Reserved	<i>To ensure compatibility with future devices, always write Reserved bits to their reset value, unless otherwise stated. More information in 1.2 Conventions</i>		
19:16	PIN CDTI2 pin select register	0x0	RW	CDTI2 pin select register
15:2	Reserved	<i>To ensure compatibility with future devices, always write Reserved bits to their reset value, unless otherwise stated. More information in 1.2 Conventions</i>		
1:0	PORT CDTI2 port select register	0x0	RW	CDTI2 port select register

24.6.139 GPIO_TIMER1_ROUTEEN - TIMER1 Pin Enable

Offset	Bit Position																																										
0x6A0	31	30	29	28	27	26	25	24	23	22	21	20	19	18	17	16	15	14	13	12	11	10	9	8	7	6	5	4	3	2	1	0											
Reset																											0x0	0x0	0x0	0x0	0x0	0x0											
Access																											RW	RW	RW	RW	RW												
Name																											CCC2PEN	CCC1PEN	CCC0PEN	CC2PEN	CC1PEN	CC0PEN											

Bit	Name	Reset	Access	Description
31:6	<i>Reserved</i>	<i>To ensure compatibility with future devices, always write Reserved bits to their reset value, unless otherwise stated. More information in 1.2 Conventions</i>		
5	CCC2PEN CDTI2 pin enable control bit	0x0	RW	CDTI2 pin enable control bit
4	CCC1PEN CDTI1 pin enable control bit	0x0	RW	CDTI1 pin enable control bit
3	CCC0PEN CDTI0 pin enable control bit	0x0	RW	CDTI0 pin enable control bit
2	CC2PEN CC2 pin enable control bit	0x0	RW	CC2 pin enable control bit
1	CC1PEN CC1 pin enable control bit	0x0	RW	CC1 pin enable control bit
0	CC0PEN CC0 pin enable control bit	0x0	RW	CC0 pin enable control bit

24.6.140 GPIO_TIMER1_CC0ROUTE - CC0 Port/Pin Select

Offset	Bit Position																															
0x6A4	31	30	29	28	27	26	25	24	23	22	21	20	19	18	17	16	15	14	13	12	11	10	9	8	7	6	5	4	3	2	1	0
Reset													0x0												0x0							
Access													RW												RW							
Name													PIN												PORT							

Bit	Name	Reset	Access	Description
31:20	Reserved	To ensure compatibility with future devices, always write Reserved bits to their reset value, unless otherwise stated. More information in 1.2 Conventions		
19:16	PIN CC0 pin select register	0x0	RW	CC0 pin select register
15:2	Reserved	To ensure compatibility with future devices, always write Reserved bits to their reset value, unless otherwise stated. More information in 1.2 Conventions		
1:0	PORT CC0 port select register	0x0	RW	CC0 port select register

24.6.141 GPIO_TIMER1_CC1ROUTE - CC1 Port/Pin Select

Offset	Bit Position																															
0x6A8	31	30	29	28	27	26	25	24	23	22	21	20	19	18	17	16	15	14	13	12	11	10	9	8	7	6	5	4	3	2	1	0
Reset													0x0												0x0							
Access													RW												RW							
Name													PIN												PORT							

Bit	Name	Reset	Access	Description
31:20	Reserved	To ensure compatibility with future devices, always write Reserved bits to their reset value, unless otherwise stated. More information in 1.2 Conventions		
19:16	PIN CC1 pin select register	0x0	RW	CC1 pin select register
15:2	Reserved	To ensure compatibility with future devices, always write Reserved bits to their reset value, unless otherwise stated. More information in 1.2 Conventions		
1:0	PORT CC1 port select register	0x0	RW	CC1 port select register

24.6.142 GPIO_TIMER1_CC2ROUTE - CC2 Port/Pin Select

Offset	Bit Position																															
0x6AC	31	30	29	28	27	26	25	24	23	22	21	20	19	18	17	16	15	14	13	12	11	10	9	8	7	6	5	4	3	2	1	0
Reset														0x0													0x0					
Access														RW													RW					
Name														PIN													PORT					

Bit	Name	Reset	Access	Description
31:20	Reserved	To ensure compatibility with future devices, always write Reserved bits to their reset value, unless otherwise stated. More information in 1.2 Conventions		
19:16	PIN CC2 pin select register	0x0	RW	CC2 pin select register
15:2	Reserved	To ensure compatibility with future devices, always write Reserved bits to their reset value, unless otherwise stated. More information in 1.2 Conventions		
1:0	PORT CC2 port select register	0x0	RW	CC2 port select register

24.6.143 GPIO_TIMER1_CDTI0ROUTE - CDTI0 Port/Pin Select

Offset	Bit Position																															
0x6B0	31	30	29	28	27	26	25	24	23	22	21	20	19	18	17	16	15	14	13	12	11	10	9	8	7	6	5	4	3	2	1	0
Reset														0x0													0x0					
Access														RW													RW					
Name														PIN													PORT					

Bit	Name	Reset	Access	Description
31:20	Reserved	To ensure compatibility with future devices, always write Reserved bits to their reset value, unless otherwise stated. More information in 1.2 Conventions		
19:16	PIN CDTI0 pin select register	0x0	RW	CDTI0 pin select register
15:2	Reserved	To ensure compatibility with future devices, always write Reserved bits to their reset value, unless otherwise stated. More information in 1.2 Conventions		
1:0	PORT CDTI0 port select register	0x0	RW	CDTI0 port select register

24.6.144 GPIO_TIMER1_CDTI1ROUTE - CDTI1 Port/Pin Select

Offset	Bit Position																																
0x6B4	31	30	29	28	27	26	25	24	23	22	21	20	19	18	17	16	15	14	13	12	11	10	9	8	7	6	5	4	3	2	1	0	
Reset														0x0																		0x0	
Access														RW																		RW	
Name														PIN																		PORT	

Bit	Name	Reset	Access	Description
31:20	Reserved	To ensure compatibility with future devices, always write Reserved bits to their reset value, unless otherwise stated. More information in 1.2 Conventions		
19:16	PIN CDTI1 pin select register	0x0	RW	CDTI1 pin select register
15:2	Reserved	To ensure compatibility with future devices, always write Reserved bits to their reset value, unless otherwise stated. More information in 1.2 Conventions		
1:0	PORT CDTI1 port select register	0x0	RW	CDTI1 port select register

24.6.145 GPIO_TIMER1_CDTI2ROUTE - CDTI2 Port/Pin Select

Offset	Bit Position																																
0x6B8	31	30	29	28	27	26	25	24	23	22	21	20	19	18	17	16	15	14	13	12	11	10	9	8	7	6	5	4	3	2	1	0	
Reset														0x0																		0x0	
Access														RW																		RW	
Name														PIN																		PORT	

Bit	Name	Reset	Access	Description
31:20	Reserved	To ensure compatibility with future devices, always write Reserved bits to their reset value, unless otherwise stated. More information in 1.2 Conventions		
19:16	PIN CDTI2 pin select register	0x0	RW	CDTI2 pin select register
15:2	Reserved	To ensure compatibility with future devices, always write Reserved bits to their reset value, unless otherwise stated. More information in 1.2 Conventions		
1:0	PORT CDTI2 port select register	0x0	RW	CDTI2 port select register

24.6.146 GPIO_TIMER2_ROUTEEN - TIMER2 Pin Enable

Offset	Bit Position																																																								
0x6C0	31	30	29	28	27	26	25	24	23	22	21	20	19	18	17	16	15	14	13	12	11	10	9	8	7	6	5	4	3	2	1	0																									
Reset																											0x0	0x0	0x0	0x0	0x0	0x0	0x0	0x0	0x0	0x0	0x0	0x0	0x0	0x0	0x0	0x0	0x0	0x0	0x0	0x0	0x0	0x0	0x0	0x0	0x0	0x0	0x0	0x0	0x0	0x0	0x0
Access																											RW	RW	RW	RW	RW	RW	RW	RW	RW	RW	RW	RW	RW	RW	RW	RW	RW	RW	RW	RW	RW	RW	RW	RW	RW	RW	RW	RW	RW	RW	RW
Name																											CCC2PEN	CCC1PEN	CCC0PEN	CC2PEN	CC1PEN	CC0PEN																									

Bit	Name	Reset	Access	Description
31:6	<i>Reserved</i>	<i>To ensure compatibility with future devices, always write Reserved bits to their reset value, unless otherwise stated. More information in 1.2 Conventions</i>		
5	CCC2PEN CDTI2 pin enable control bit	0x0	RW	CDTI2 pin enable control bit
4	CCC1PEN CDTI1 pin enable control bit	0x0	RW	CDTI1 pin enable control bit
3	CCC0PEN CDTI0 pin enable control bit	0x0	RW	CDTI0 pin enable control bit
2	CC2PEN CC2 pin enable control bit	0x0	RW	CC2 pin enable control bit
1	CC1PEN CC1 pin enable control bit	0x0	RW	CC1 pin enable control bit
0	CC0PEN CC0 pin enable control bit	0x0	RW	CC0 pin enable control bit

24.6.147 GPIO_TIMER2_CC0ROUTE - CC0 Port/Pin Select

Offset	Bit Position																															
0x6C4	31	30	29	28	27	26	25	24	23	22	21	20	19	18	17	16	15	14	13	12	11	10	9	8	7	6	5	4	3	2	1	0
Reset													0x0												0x0							
Access													RW												RW							
Name													PIN												PORT							

Bit	Name	Reset	Access	Description
31:20	Reserved	To ensure compatibility with future devices, always write Reserved bits to their reset value, unless otherwise stated. More information in 1.2 Conventions		
19:16	PIN CC0 pin select register	0x0	RW	CC0 pin select register
15:2	Reserved	To ensure compatibility with future devices, always write Reserved bits to their reset value, unless otherwise stated. More information in 1.2 Conventions		
1:0	PORT CC0 port select register	0x0	RW	CC0 port select register

24.6.148 GPIO_TIMER2_CC1ROUTE - CC1 Port/Pin Select

Offset	Bit Position																															
0x6C8	31	30	29	28	27	26	25	24	23	22	21	20	19	18	17	16	15	14	13	12	11	10	9	8	7	6	5	4	3	2	1	0
Reset													0x0												0x0							
Access													RW												RW							
Name													PIN												PORT							

Bit	Name	Reset	Access	Description
31:20	Reserved	To ensure compatibility with future devices, always write Reserved bits to their reset value, unless otherwise stated. More information in 1.2 Conventions		
19:16	PIN CC1 pin select register	0x0	RW	CC1 pin select register
15:2	Reserved	To ensure compatibility with future devices, always write Reserved bits to their reset value, unless otherwise stated. More information in 1.2 Conventions		
1:0	PORT CC1 port select register	0x0	RW	CC1 port select register

24.6.149 GPIO_TIMER2_CC2ROUTE - CC2 Port/Pin Select

Offset	Bit Position																															
0x6CC	31	30	29	28	27	26	25	24	23	22	21	20	19	18	17	16	15	14	13	12	11	10	9	8	7	6	5	4	3	2	1	0
Reset													0x0																0x0			
Access													RW																RW			
Name													PIN																PORT			

Bit	Name	Reset	Access	Description
31:20	Reserved	To ensure compatibility with future devices, always write Reserved bits to their reset value, unless otherwise stated. More information in 1.2 Conventions		
19:16	PIN CC2 pin select register	0x0	RW	CC2 pin select register
15:2	Reserved	To ensure compatibility with future devices, always write Reserved bits to their reset value, unless otherwise stated. More information in 1.2 Conventions		
1:0	PORT CC2 port select register	0x0	RW	CC2 port select register

24.6.150 GPIO_TIMER2_CDTI0ROUTE - CDTI0 Port/Pin Select

Offset	Bit Position																															
0x6D0	31	30	29	28	27	26	25	24	23	22	21	20	19	18	17	16	15	14	13	12	11	10	9	8	7	6	5	4	3	2	1	0
Reset													0x0																0x0			
Access													RW																RW			
Name													PIN																PORT			

Bit	Name	Reset	Access	Description
31:20	Reserved	To ensure compatibility with future devices, always write Reserved bits to their reset value, unless otherwise stated. More information in 1.2 Conventions		
19:16	PIN CDTI0 pin select register	0x0	RW	CDTI0 pin select register
15:2	Reserved	To ensure compatibility with future devices, always write Reserved bits to their reset value, unless otherwise stated. More information in 1.2 Conventions		
1:0	PORT CDTI0 port select register	0x0	RW	CDTI0 port select register

24.6.151 GPIO_TIMER2_CDTI1ROUTE - CDTI1 Port/Pin Select

Offset	Bit Position																															
0x6D4	31	30	29	28	27	26	25	24	23	22	21	20	19	18	17	16	15	14	13	12	11	10	9	8	7	6	5	4	3	2	1	0
Reset													0x0																0x0			
Access													RW																RW			
Name													PIN																PORT			

Bit	Name	Reset	Access	Description
31:20	Reserved	To ensure compatibility with future devices, always write Reserved bits to their reset value, unless otherwise stated. More information in 1.2 Conventions		
19:16	PIN CDTI1 pin select register	0x0	RW	CDTI1 pin select register
15:2	Reserved	To ensure compatibility with future devices, always write Reserved bits to their reset value, unless otherwise stated. More information in 1.2 Conventions		
1:0	PORT CDTI1 port select register	0x0	RW	CDTI1 port select register

24.6.152 GPIO_TIMER2_CDTI2ROUTE - CDTI2 Port/Pin Select

Offset	Bit Position																															
0x6D8	31	30	29	28	27	26	25	24	23	22	21	20	19	18	17	16	15	14	13	12	11	10	9	8	7	6	5	4	3	2	1	0
Reset													0x0																0x0			
Access													RW																RW			
Name													PIN																PORT			

Bit	Name	Reset	Access	Description
31:20	Reserved	To ensure compatibility with future devices, always write Reserved bits to their reset value, unless otherwise stated. More information in 1.2 Conventions		
19:16	PIN CDTI2 pin select register	0x0	RW	CDTI2 pin select register
15:2	Reserved	To ensure compatibility with future devices, always write Reserved bits to their reset value, unless otherwise stated. More information in 1.2 Conventions		
1:0	PORT CDTI2 port select register	0x0	RW	CDTI2 port select register

24.6.153 GPIO_TIMER3_ROUTEEN - TIMER3 Pin Enable

Offset	Bit Position																																																				
0x6E0	31	30	29	28	27	26	25	24	23	22	21	20	19	18	17	16	15	14	13	12	11	10	9	8	7	6	5	4	3	2	1	0																					
Reset																											0x0	0x0	0x0	0x0	0x0	0x0	0x0																				
Access																											RW	RW	RW	RW	RW	RW	RW																				
Name																											CCC2PEN	CCC1PEN	CCC0PEN	CC2PEN	CC1PEN	CC0PEN																					

Bit	Name	Reset	Access	Description
31:6	<i>Reserved</i>	<i>To ensure compatibility with future devices, always write Reserved bits to their reset value, unless otherwise stated. More information in 1.2 Conventions</i>		
5	CCC2PEN CDTI2 pin enable control bit	0x0	RW	CDTI2 pin enable control bit
4	CCC1PEN CDTI1 pin enable control bit	0x0	RW	CDTI1 pin enable control bit
3	CCC0PEN CDTI0 pin enable control bit	0x0	RW	CDTI0 pin enable control bit
2	CC2PEN CC2 pin enable control bit	0x0	RW	CC2 pin enable control bit
1	CC1PEN CC1 pin enable control bit	0x0	RW	CC1 pin enable control bit
0	CC0PEN CC0 pin enable control bit	0x0	RW	CC0 pin enable control bit

24.6.154 GPIO_TIMER3_CC0ROUTE - CC0 Port/Pin Select

Offset	Bit Position																															
0x6E4	31	30	29	28	27	26	25	24	23	22	21	20	19	18	17	16	15	14	13	12	11	10	9	8	7	6	5	4	3	2	1	0
Reset														0x0													0x0					
Access														RW													RW					
Name														PIN													PORT					

Bit	Name	Reset	Access	Description
31:20	Reserved	To ensure compatibility with future devices, always write Reserved bits to their reset value, unless otherwise stated. More information in 1.2 Conventions		
19:16	PIN CC0 pin select register	0x0	RW	CC0 pin select register
15:2	Reserved	To ensure compatibility with future devices, always write Reserved bits to their reset value, unless otherwise stated. More information in 1.2 Conventions		
1:0	PORT CC0 port select register	0x0	RW	CC0 port select register

24.6.155 GPIO_TIMER3_CC1ROUTE - CC1 Port/Pin Select

Offset	Bit Position																															
0x6E8	31	30	29	28	27	26	25	24	23	22	21	20	19	18	17	16	15	14	13	12	11	10	9	8	7	6	5	4	3	2	1	0
Reset														0x0													0x0					
Access														RW													RW					
Name														PIN													PORT					

Bit	Name	Reset	Access	Description
31:20	Reserved	To ensure compatibility with future devices, always write Reserved bits to their reset value, unless otherwise stated. More information in 1.2 Conventions		
19:16	PIN CC1 pin select register	0x0	RW	CC1 pin select register
15:2	Reserved	To ensure compatibility with future devices, always write Reserved bits to their reset value, unless otherwise stated. More information in 1.2 Conventions		
1:0	PORT CC1 port select register	0x0	RW	CC1 port select register

24.6.156 GPIO_TIMER3_CC2ROUTE - CC2 Port/Pin Select

Offset	Bit Position																															
0x6EC	31	30	29	28	27	26	25	24	23	22	21	20	19	18	17	16	15	14	13	12	11	10	9	8	7	6	5	4	3	2	1	0
Reset														0x0																0x0		
Access														RW																RW		
Name														PIN																PORT		

Bit	Name	Reset	Access	Description
31:20	Reserved	To ensure compatibility with future devices, always write Reserved bits to their reset value, unless otherwise stated. More information in 1.2 Conventions		
19:16	PIN CC2 pin select register	0x0	RW	CC2 pin select register
15:2	Reserved	To ensure compatibility with future devices, always write Reserved bits to their reset value, unless otherwise stated. More information in 1.2 Conventions		
1:0	PORT CC2 port select register	0x0	RW	CC2 port select register

24.6.157 GPIO_TIMER3_CDTI0ROUTE - CDTI0 Port/Pin Select

Offset	Bit Position																															
0x6F0	31	30	29	28	27	26	25	24	23	22	21	20	19	18	17	16	15	14	13	12	11	10	9	8	7	6	5	4	3	2	1	0
Reset														0x0																0x0		
Access														RW																RW		
Name														PIN																PORT		

Bit	Name	Reset	Access	Description
31:20	Reserved	To ensure compatibility with future devices, always write Reserved bits to their reset value, unless otherwise stated. More information in 1.2 Conventions		
19:16	PIN CDTI0 pin select register	0x0	RW	CDTI0 pin select register
15:2	Reserved	To ensure compatibility with future devices, always write Reserved bits to their reset value, unless otherwise stated. More information in 1.2 Conventions		
1:0	PORT CDTI0 port select register	0x0	RW	CDTI0 port select register

24.6.158 GPIO_TIMER3_CDTI1ROUTE - CDTI1 Port/Pin Select

Offset	Bit Position																															
0x6F4	31	30	29	28	27	26	25	24	23	22	21	20	19	18	17	16	15	14	13	12	11	10	9	8	7	6	5	4	3	2	1	0
Reset													0x0																0x0			
Access													RW																RW			
Name													PIN																PORT			

Bit	Name	Reset	Access	Description
31:20	Reserved	<i>To ensure compatibility with future devices, always write Reserved bits to their reset value, unless otherwise stated. More information in 1.2 Conventions</i>		
19:16	PIN CDTI1 pin select register	0x0	RW	CDTI1 pin select register
15:2	Reserved	<i>To ensure compatibility with future devices, always write Reserved bits to their reset value, unless otherwise stated. More information in 1.2 Conventions</i>		
1:0	PORT CDTI1 port select register	0x0	RW	CDTI1 port select register

24.6.159 GPIO_TIMER3_CDTI2ROUTE - CDTI2 Port/Pin Select

Offset	Bit Position																															
0x6F8	31	30	29	28	27	26	25	24	23	22	21	20	19	18	17	16	15	14	13	12	11	10	9	8	7	6	5	4	3	2	1	0
Reset													0x0																0x0			
Access													RW																RW			
Name													PIN																PORT			

Bit	Name	Reset	Access	Description
31:20	Reserved	<i>To ensure compatibility with future devices, always write Reserved bits to their reset value, unless otherwise stated. More information in 1.2 Conventions</i>		
19:16	PIN CDTI2 pin select register	0x0	RW	CDTI2 pin select register
15:2	Reserved	<i>To ensure compatibility with future devices, always write Reserved bits to their reset value, unless otherwise stated. More information in 1.2 Conventions</i>		
1:0	PORT CDTI2 port select register	0x0	RW	CDTI2 port select register

24.6.160 GPIO_TIMER4_ROUTEEN - TIMER4 Pin Enable

Offset	Bit Position																																																								
0x700	31	30	29	28	27	26	25	24	23	22	21	20	19	18	17	16	15	14	13	12	11	10	9	8	7	6	5	4	3	2	1	0																									
Reset																											0x0	0x0	0x0	0x0	0x0	0x0	0x0	0x0	0x0	0x0	0x0	0x0	0x0	0x0	0x0	0x0	0x0	0x0	0x0	0x0	0x0	0x0	0x0	0x0	0x0	0x0	0x0	0x0	0x0	0x0	
Access																											RW	RW	RW	RW	RW	RW	RW	RW	RW	RW	RW	RW	RW	RW	RW	RW	RW	RW	RW	RW	RW	RW	RW	RW	RW	RW	RW	RW	RW	RW	RW
Name																											CCC2PEN	CCC1PEN	CCC0PEN	CC2PEN	CC1PEN	CC0PEN																									

Bit	Name	Reset	Access	Description
31:6	<i>Reserved</i>	<i>To ensure compatibility with future devices, always write Reserved bits to their reset value, unless otherwise stated. More information in 1.2 Conventions</i>		
5	CCC2PEN CDTI2 pin enable control bit	0x0	RW	CDTI2 pin enable control bit
4	CCC1PEN CDTI1 pin enable control bit	0x0	RW	CDTI1 pin enable control bit
3	CCC0PEN CDTI0 pin enable control bit	0x0	RW	CDTI0 pin enable control bit
2	CC2PEN CC2 pin enable control bit	0x0	RW	CC2 pin enable control bit
1	CC1PEN CC1 pin enable control bit	0x0	RW	CC1 pin enable control bit
0	CC0PEN CC0 pin enable control bit	0x0	RW	CC0 pin enable control bit

24.6.161 GPIO_TIMER4_CC0ROUTE - CC0 Port/Pin Select

Offset	Bit Position																															
0x704	31	30	29	28	27	26	25	24	23	22	21	20	19	18	17	16	15	14	13	12	11	10	9	8	7	6	5	4	3	2	1	0
Reset														0x0													0x0					
Access														RW													RW					
Name														PIN													PORT					

Bit	Name	Reset	Access	Description
31:20	Reserved	To ensure compatibility with future devices, always write Reserved bits to their reset value, unless otherwise stated. More information in 1.2 Conventions		
19:16	PIN CC0 pin select register	0x0	RW	CC0 pin select register
15:2	Reserved	To ensure compatibility with future devices, always write Reserved bits to their reset value, unless otherwise stated. More information in 1.2 Conventions		
1:0	PORT CC0 port select register	0x0	RW	CC0 port select register

24.6.162 GPIO_TIMER4_CC1ROUTE - CC1 Port/Pin Select

Offset	Bit Position																															
0x708	31	30	29	28	27	26	25	24	23	22	21	20	19	18	17	16	15	14	13	12	11	10	9	8	7	6	5	4	3	2	1	0
Reset														0x0													0x0					
Access														RW													RW					
Name														PIN													PORT					

Bit	Name	Reset	Access	Description
31:20	Reserved	To ensure compatibility with future devices, always write Reserved bits to their reset value, unless otherwise stated. More information in 1.2 Conventions		
19:16	PIN CC1 pin select register	0x0	RW	CC1 pin select register
15:2	Reserved	To ensure compatibility with future devices, always write Reserved bits to their reset value, unless otherwise stated. More information in 1.2 Conventions		
1:0	PORT CC1 port select register	0x0	RW	CC1 port select register

24.6.163 GPIO_TIMER4_CC2ROUTE - CC2 Port/Pin Select

Offset	Bit Position																															
0x70C	31	30	29	28	27	26	25	24	23	22	21	20	19	18	17	16	15	14	13	12	11	10	9	8	7	6	5	4	3	2	1	0
Reset														0x0													0x0					
Access														RW													RW					
Name														PIN													PORT					

Bit	Name	Reset	Access	Description
31:20	Reserved	To ensure compatibility with future devices, always write Reserved bits to their reset value, unless otherwise stated. More information in 1.2 Conventions		
19:16	PIN CC2 pin select register	0x0	RW	CC2 pin select register
15:2	Reserved	To ensure compatibility with future devices, always write Reserved bits to their reset value, unless otherwise stated. More information in 1.2 Conventions		
1:0	PORT CC2 port select register	0x0	RW	CC2 port select register

24.6.164 GPIO_TIMER4_CDTI0ROUTE - CDTI0 Port/Pin Select

Offset	Bit Position																															
0x710	31	30	29	28	27	26	25	24	23	22	21	20	19	18	17	16	15	14	13	12	11	10	9	8	7	6	5	4	3	2	1	0
Reset														0x0													0x0					
Access														RW													RW					
Name														PIN													PORT					

Bit	Name	Reset	Access	Description
31:20	Reserved	To ensure compatibility with future devices, always write Reserved bits to their reset value, unless otherwise stated. More information in 1.2 Conventions		
19:16	PIN CDTI0 pin select register	0x0	RW	CDTI0 pin select register
15:2	Reserved	To ensure compatibility with future devices, always write Reserved bits to their reset value, unless otherwise stated. More information in 1.2 Conventions		
1:0	PORT CDTI0 port select register	0x0	RW	CDTI0 port select register

24.6.165 GPIO_TIMER4_CDTI1ROUTE - CDTI1 Port/Pin Select

Offset	Bit Position																															
0x714	31	30	29	28	27	26	25	24	23	22	21	20	19	18	17	16	15	14	13	12	11	10	9	8	7	6	5	4	3	2	1	0
Reset													0x0																0x0			
Access													RW																RW			
Name													PIN																PORT			

Bit	Name	Reset	Access	Description
31:20	Reserved	To ensure compatibility with future devices, always write Reserved bits to their reset value, unless otherwise stated. More information in 1.2 Conventions		
19:16	PIN CDTI1 pin select register	0x0	RW	CDTI1 pin select register
15:2	Reserved	To ensure compatibility with future devices, always write Reserved bits to their reset value, unless otherwise stated. More information in 1.2 Conventions		
1:0	PORT CDTI1 port select register	0x0	RW	CDTI1 port select register

24.6.166 GPIO_TIMER4_CDTI2ROUTE - CDTI2 Port/Pin Select

Offset	Bit Position																															
0x718	31	30	29	28	27	26	25	24	23	22	21	20	19	18	17	16	15	14	13	12	11	10	9	8	7	6	5	4	3	2	1	0
Reset													0x0																0x0			
Access													RW																RW			
Name													PIN																PORT			

Bit	Name	Reset	Access	Description
31:20	Reserved	To ensure compatibility with future devices, always write Reserved bits to their reset value, unless otherwise stated. More information in 1.2 Conventions		
19:16	PIN CDTI2 pin select register	0x0	RW	CDTI2 pin select register
15:2	Reserved	To ensure compatibility with future devices, always write Reserved bits to their reset value, unless otherwise stated. More information in 1.2 Conventions		
1:0	PORT CDTI2 port select register	0x0	RW	CDTI2 port select register

24.6.167 GPIO_USART0_ROUTEEN - USART0 Pin Enable

Offset	Bit Position																															
0x720	31	30	29	28	27	26	25	24	23	22	21	20	19	18	17	16	15	14	13	12	11	10	9	8	7	6	5	4	3	2	1	0
Reset																										0x0	0x0	0x0	0x0	0x0		
Access																										RW	RW	RW	RW	RW		
Name																										TXPEN	CLKPEN	RXPEN	RTSPEN	CSPEN		

Bit	Name	Reset	Access	Description
31:5	Reserved	<i>To ensure compatibility with future devices, always write Reserved bits to their reset value, unless otherwise stated. More information in 1.2 Conventions</i>		
4	TXPEN TX pin enable control bit	0x0	RW	TX pin enable control bit
3	CLKPEN SCLK pin enable control bit	0x0	RW	SCLK pin enable control bit
2	RXPEN RX pin enable control bit	0x0	RW	RX pin enable control bit
1	RTSPEN RTS pin enable control bit	0x0	RW	RTS pin enable control bit
0	CSPEN CS pin enable control bit	0x0	RW	CS pin enable control bit

24.6.168 GPIO_USART0_CSROUTE - CS Port/Pin Select

Offset	Bit Position																															
0x724	31	30	29	28	27	26	25	24	23	22	21	20	19	18	17	16	15	14	13	12	11	10	9	8	7	6	5	4	3	2	1	0
Reset													0x0																0x0			
Access													RW																RW			
Name													PIN																PORT			

Bit	Name	Reset	Access	Description
31:20	Reserved	To ensure compatibility with future devices, always write Reserved bits to their reset value, unless otherwise stated. More information in 1.2 Conventions		
19:16	PIN CS pin select register	0x0	RW	CS pin select register
15:2	Reserved	To ensure compatibility with future devices, always write Reserved bits to their reset value, unless otherwise stated. More information in 1.2 Conventions		
1:0	PORT CS port select register	0x0	RW	CS port select register

24.6.169 GPIO_USART0_CTSROUTE - CTS Port/Pin Select

Offset	Bit Position																															
0x728	31	30	29	28	27	26	25	24	23	22	21	20	19	18	17	16	15	14	13	12	11	10	9	8	7	6	5	4	3	2	1	0
Reset													0x0																0x0			
Access													RW																RW			
Name													PIN																PORT			

Bit	Name	Reset	Access	Description
31:20	Reserved	To ensure compatibility with future devices, always write Reserved bits to their reset value, unless otherwise stated. More information in 1.2 Conventions		
19:16	PIN CTS pin select register	0x0	RW	CTS pin select register
15:2	Reserved	To ensure compatibility with future devices, always write Reserved bits to their reset value, unless otherwise stated. More information in 1.2 Conventions		
1:0	PORT CTS port select register	0x0	RW	CTS port select register

24.6.170 GPIO_USART0_RTROUTE - RTS Port/Pin Select

Offset	Bit Position																															
0x72C	31	30	29	28	27	26	25	24	23	22	21	20	19	18	17	16	15	14	13	12	11	10	9	8	7	6	5	4	3	2	1	0
Reset													0x0																0x0			
Access													RW																RW			
Name													PIN																PORT			

Bit	Name	Reset	Access	Description
31:20	Reserved	To ensure compatibility with future devices, always write Reserved bits to their reset value, unless otherwise stated. More information in 1.2 Conventions		
19:16	PIN RTS pin select register	0x0	RW	RTS pin select register
15:2	Reserved	To ensure compatibility with future devices, always write Reserved bits to their reset value, unless otherwise stated. More information in 1.2 Conventions		
1:0	PORT RTS port select register	0x0	RW	RTS port select register

24.6.171 GPIO_USART0_RXROUTE - RX Port/Pin Select

Offset	Bit Position																															
0x730	31	30	29	28	27	26	25	24	23	22	21	20	19	18	17	16	15	14	13	12	11	10	9	8	7	6	5	4	3	2	1	0
Reset													0x0																0x0			
Access													RW																RW			
Name													PIN																PORT			

Bit	Name	Reset	Access	Description
31:20	Reserved	To ensure compatibility with future devices, always write Reserved bits to their reset value, unless otherwise stated. More information in 1.2 Conventions		
19:16	PIN RX pin select register	0x0	RW	RX pin select register
15:2	Reserved	To ensure compatibility with future devices, always write Reserved bits to their reset value, unless otherwise stated. More information in 1.2 Conventions		
1:0	PORT RX port select register	0x0	RW	RX port select register

24.6.172 GPIO_USART0_CLKROUTE - SCLK Port/Pin Select

Offset	Bit Position																															
0x734	31	30	29	28	27	26	25	24	23	22	21	20	19	18	17	16	15	14	13	12	11	10	9	8	7	6	5	4	3	2	1	0
Reset													0x0																0x0			
Access													RW																RW			
Name													PIN																PORT			

Bit	Name	Reset	Access	Description
31:20	Reserved	<i>To ensure compatibility with future devices, always write Reserved bits to their reset value, unless otherwise stated. More information in 1.2 Conventions</i>		
19:16	PIN SCLK pin select register	0x0	RW	SCLK pin select register
15:2	Reserved	<i>To ensure compatibility with future devices, always write Reserved bits to their reset value, unless otherwise stated. More information in 1.2 Conventions</i>		
1:0	PORT SCLK port select register	0x0	RW	SCLK port select register

24.6.173 GPIO_USART0_TXROUTE - TX Port/Pin Select

Offset	Bit Position																															
0x738	31	30	29	28	27	26	25	24	23	22	21	20	19	18	17	16	15	14	13	12	11	10	9	8	7	6	5	4	3	2	1	0
Reset													0x0																0x0			
Access													RW																RW			
Name													PIN																PORT			

Bit	Name	Reset	Access	Description
31:20	Reserved	<i>To ensure compatibility with future devices, always write Reserved bits to their reset value, unless otherwise stated. More information in 1.2 Conventions</i>		
19:16	PIN TX pin select register	0x0	RW	TX pin select register
15:2	Reserved	<i>To ensure compatibility with future devices, always write Reserved bits to their reset value, unless otherwise stated. More information in 1.2 Conventions</i>		
1:0	PORT TX port select register	0x0	RW	TX port select register

25. LDMA - Linked DMA

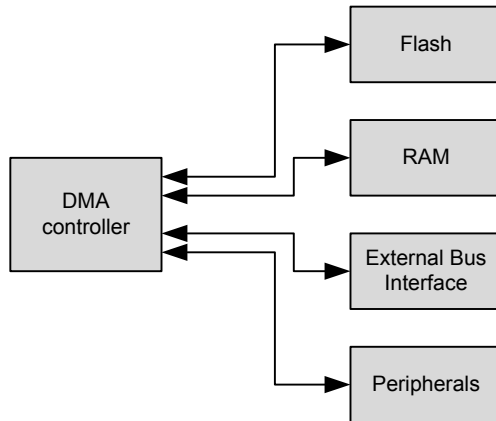
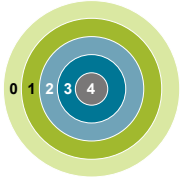

25.1 Introduction

The Linked Direct Memory Access (LDMA) controller performs memory transfer operations independently of the CPU. This has the benefit of reducing the energy consumption and the workload of the CPU, and enables the system to stay in low energy modes while still routing data to memory and peripherals. For example, moving data from the ADC to memory.

Quick Facts

What?

The LDMA controller can move data without CPU intervention, effectively reducing the energy consumption for a data transfer.

Why?

The LDMA can perform data transfers more energy efficiently than the CPU and allows autonomous operation in low energy modes.

How?

The LDMA controller has multiple highly configurable, prioritized DMA channels. A linked list of flexible descriptors makes it possible to tailor the controller to the specific needs of an application.

25.1.1 Features

- Flexible Source and Destination transfers
 - Memory-to-memory
 - Memory-to-peripheral
 - Peripheral-to-memory
 - Peripheral-to-peripheral
- DMA transfers triggered by peripherals, software, or linked list
- Single or multiple data transfers for each peripheral or software request
- Inter-channel and hardware event synchronization via trigger and wait functions
- Supports single or multiple descriptors
 - Single descriptor
 - Linked list of descriptors
 - Circular and ping-pong buffers
 - Scatter-Gather
 - Looping
 - Pause and restart triggered by other channels
 - Sophisticated flow control which can function without CPU interaction
- Channel arbitration includes:
 - Fixed priority
 - Simple round robin
 - Round robin with programmable multiple interleaved entries for higher priority requesters
- Programmable data size and source and destination address strides
- Programmable interrupt generation at the end of each DMA descriptor execution
- Little-endian/big-endian conversion
- DMA write-immediate function

25.2 Block Diagram

An overview of the LDMA and the modules it interacts with is shown in [Figure 25.1 LDMA Block Diagram on page 984](#).

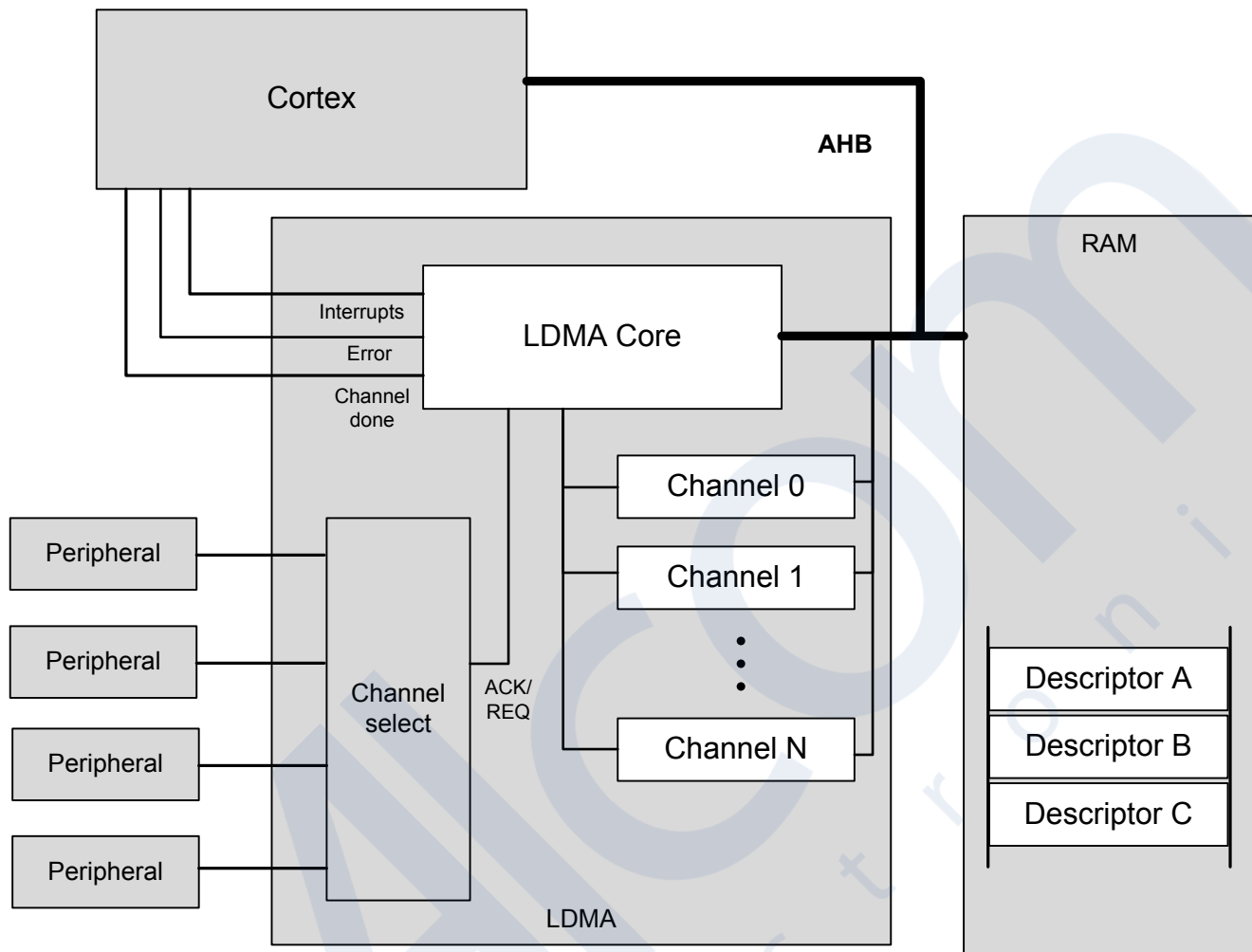

Figure 25.1. LDMA Block Diagram

The Linked DMA Controller consists of three main parts

- A DMA core that executes transfers and communicates status to the core
- A channel select block that routes peripheral DMA requests and acknowledge signals to the DMA
- A set of internal channel configuration registers for tracking the progress of each DMA channel

The DMA has access to all system memory through the AHB bus and the AHB->APB bridge. It can load channel descriptors from memory with no CPU intervention.

25.3 Functional Description

The Linked DMA Controller is highly flexible. It is capable of transferring data between peripherals and memory without involvement from the processor core. This can be used to increase system performance by off-loading the processor from copying large amounts of data or avoiding frequent interrupts to service peripherals needing more data or having available data. It can also be used to reduce the system energy consumption by making the LDMA work autonomously with some EM2/3 peripherals for data transfer without having to wake up the processor core from sleep.

The Linked DMA Controller has 8 independent channels. Each of these channels can be connected to any of the available peripheral DMA transfer request input sources by writing to the channel configuration registers, see [25.3.2 Channel Configuration](#). In addition, each channel can also be triggered directly by software, which is useful for memory-to-memory transfers.

The channel descriptors determine what the Linked DMA Controller will do when it receives DMA transfer request. The initial descriptor is written directly to the LDMA's channel registers. If desired, the initial descriptor can link to additional linked descriptors stored in memory (RAM or Flash). Alternatively, software may also load the initial descriptor by writing the descriptor address to the LDMA_CHx_LINK register and then setting the corresponding bit the LDMA_LINKLOAD register.

Before enabling a channel, the software must take care to properly configure the channel registers including the link address and any linked descriptors. When a channel is triggered, the Linked DMA Controller will perform the memory transfers as specified by the descriptors. A descriptor contains the memory address to read from, the memory address to write to, link address of the next descriptor, the number of bytes to be transferred, etc. The channel descriptor is described in detail in [25.3.7 Channel Descriptor Data Structure](#).

The Linked DMA Controller supports both fixed priority and round robin arbitration. The number of fixed and round robin channels is programmable. For round robin channels, the number of arbitration slots requested for each channel is programmable. Using this scheme, it is possible to ensure that timing-critical transfers are serviced on time.

DMA transfers take place by reading a block of data at a time from the source, storing it in the LDMA's local FIFO, then writing the block out to the destination from the FIFO. Interrupts may optionally be signaled to the CPU's interrupt controller at the end of any DMA transfer or at the completion of a descriptor if the DONEIFSEN bit is set. An AHB error will always generate an interrupt.

25.3.1 Channel Descriptor

Each DMA channel has descriptor registers. A transfer can be initialized by software writing to the registers or by the DMA itself copying a descriptor from RAM to memory. When using a linked list of descriptors the first descriptor should be initialized by the CPU. The DMA itself will then copy linked descriptors to its descriptor registers as required. In addition to manually initializing the first transfer, software may also cause the LDMA to load the initial descriptor by writing the descriptor address to the LDMA_CHx_LINK register and then setting the corresponding bit the LDMA_LINKLOAD register.

The contents of the descriptor registers are dynamically updated during the DMA transfer. The contents of descriptors in memory are not edited by the controller.

Some descriptor field values are only used for linked descriptors. For example, the SRCMODE and DSTMODE bits of the LDMA_CHx_CTRL registers determine if a linked descriptor is using relative or absolute addressing. Software writes to the address registers will always use absolute addressing and never set these bits. Therefore, these bits are read only.

25.3.1.1 DMA Transfer Size

A DMA transfer is the smallest unit of data that can be transferred by the LDMA. The LDMA supports byte, half-word and word sized transfers. The SIZE field in the LDMA_CHx_CTRL register specifies the data width of one DMA transfer.

25.3.1.2 Source/Destination Increments

The SRCINC and DSTINC in the LDMA_CHx_CTRL register determines the increment between DMA transfers. The increment is in units of DMA transfers and using an increment size of 1 will transfer contiguous bytes, half-words, or words depending on the value of the SIZE field. Multiple unit increments are useful for transferring or packing/unpacking aligned data. For example using an increment of 4 with a size of BYTE will transfer word aligned bytes. An increment of 2 units with a size of HALFWORD is suitable for the transfer of word aligned half-word data. The LDMA can also pack or unpack data by using a different increment size for source and destination. For example - to convert from word aligned byte data (unpacked) to contiguous byte data (packed), set the SIZE to BYTE, SRCINC to 4, and DSTINC to 1.

SIZE may also be set to NONE which will cause the LDMA to read or write the same location for every DMA transfer. This is useful for accessing peripheral FIFO or data registers.

25.3.1.3 Block Size

The block size defines the amount of data transferred in one arbitration. It consists of one or more DMA transfers. See [25.3.6.1 Arbitration Priority](#) for more details.

25.3.1.4 Transfer Count

The descriptor transfer count defines how many DMA transfers to perform. The number of bytes transferred by the descriptor will depend on both the transfer count XFERCNT and the SIZE field settings. $TOTAL_BYTES = XFERCNT * SIZE$

25.3.1.5 Descriptor List

A descriptor list consists of one or more descriptors which are executed serially. This list may be a simple sequence of descriptors, a loop of descriptors, or a combination of the two.

Each descriptor in the list can be one of several types.

- Single Transfer descriptor: Transfers TOTAL_BYTES of data and then stops.
- Linked Transfer descriptor: Transfers TOTAL_BYTES of data and then loads the next linked descriptor.
- Loop Transfer descriptor: Transfers TOTAL_BYTES of data and performs loop control (see [25.3.2.2 Loop Counter](#)).
- Sync descriptor: Handle synchronization of the list with other entities (see [25.3.7.2 SYNC Descriptor Structure](#)).
- WRI descriptor: Writes a value to a location in memory (see [25.3.7.3 WRI Descriptor Structure](#)).

25.3.1.6 Addresses

Before initiating a transfer, software should write the source address, destination address, and if applicable the link address to the descriptor registers. Alternatively, software may load a descriptor from memory by writing the descriptor address to the LDMA_CHx_LINK register and setting the corresponding bit in the LDMA_LINKLOAD register.

During a DMA transfer, the DMA source and destination address registers are pointers to the next transfer address. The LDMA will update the SRC and DST addresses after each transfer. If software halts a DMA transfer by clearing the enable bit, the SRC and DST addresses will indicate the next transfer address.

When a descriptor is finished the DMA will either halt or load the next (linked) descriptor depending on the value of the LINK field in the LDMA_Chx_LINK register. After loading a linked descriptor, the descriptor registers will reflect the content of the loaded descriptor. Note that the linked descriptor must be word aligned in memory. The two least significant bits of the LDMA_CHx_LINK register are used by the LINK and LINKMODE bits. The two least significant bits of the link address are always zero.

25.3.1.7 Addressing Modes

The DMA descriptors support absolute addressing or relative addressing. When using relative addressing, the offset is relative to the current contents of the respective address registers. Regardless of the descriptor addressing modes, the address registers always indicate the absolute address. For example, when loading a descriptor using relative SRC addressing, the LDMA will add the descriptor source address (offset) to the contents of the SRCADDR register (base address). After loading, the SRCADDR register will indicate the absolute address of the loaded descriptor.

The initial descriptor must use absolute addressing. The LDMA will ignore the DSTMODE, SRCMODE, and LINKMODE bits for the initial descriptor and interpret the addresses as an absolute addresses.

Relative addressing is most useful for the link address. The initial descriptor will indicate the absolute address of the linked descriptors in memory. The linked descriptors might be an array of structures. In this case the offset between descriptors is constant and is always 4 words or 16 bytes (each descriptor has 4 words). The LINK address is not incremented or decremented after each transfer. Thus, a relative offset of 0x10 may be used for all linked descriptors.

The source and destination addresses also support relative addressing. When using relative addressing with the source or destination address registers, the LDMA adds the relative offset to the current contents of the respective address register. Since the source and destination addresses are normally incremented after each transfer, the final address will point to one unit past the last transfer. Thus, an offset of zero will give the next sequential data address.

See the example [25.4.6 2D Copy](#) for an common use of relative addressing.

25.3.1.8 Byte Swap

Enabling byte swap reverses the endianness of the incoming source data read into the LDMA's FIFO. Byte swap is only valid for transfer sizes of word and half-word. Note that linked structure reads are not byte swapped.

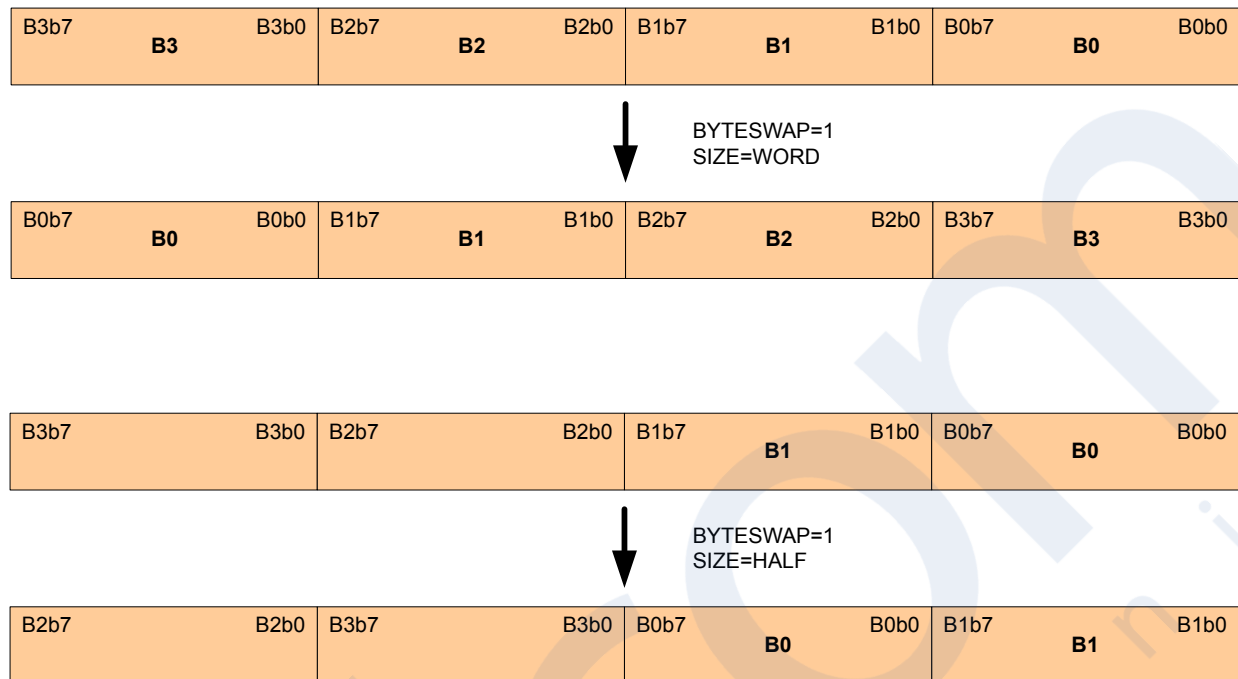

Figure 25.2. Word and Half-Word Endian Byte Swap Examples

25.3.1.9 DMA Size and Source/Destination Increment Programming

The DMA channels' SIZE, SRCINC, and DSTINC bit-fields are programmed to best utilize memory resources. They provide a means for memory packing and unpacking, as well as for matching the size of data being transmitted to or received from an IO peripheral. The following figure shows how 32-bit words of data are read from a memory source into the DMA's internal transfer FIFO, and then written out to the memory destination. The memory organization in bytes is shown as well as the first read to and write from the DMA's FIFO.

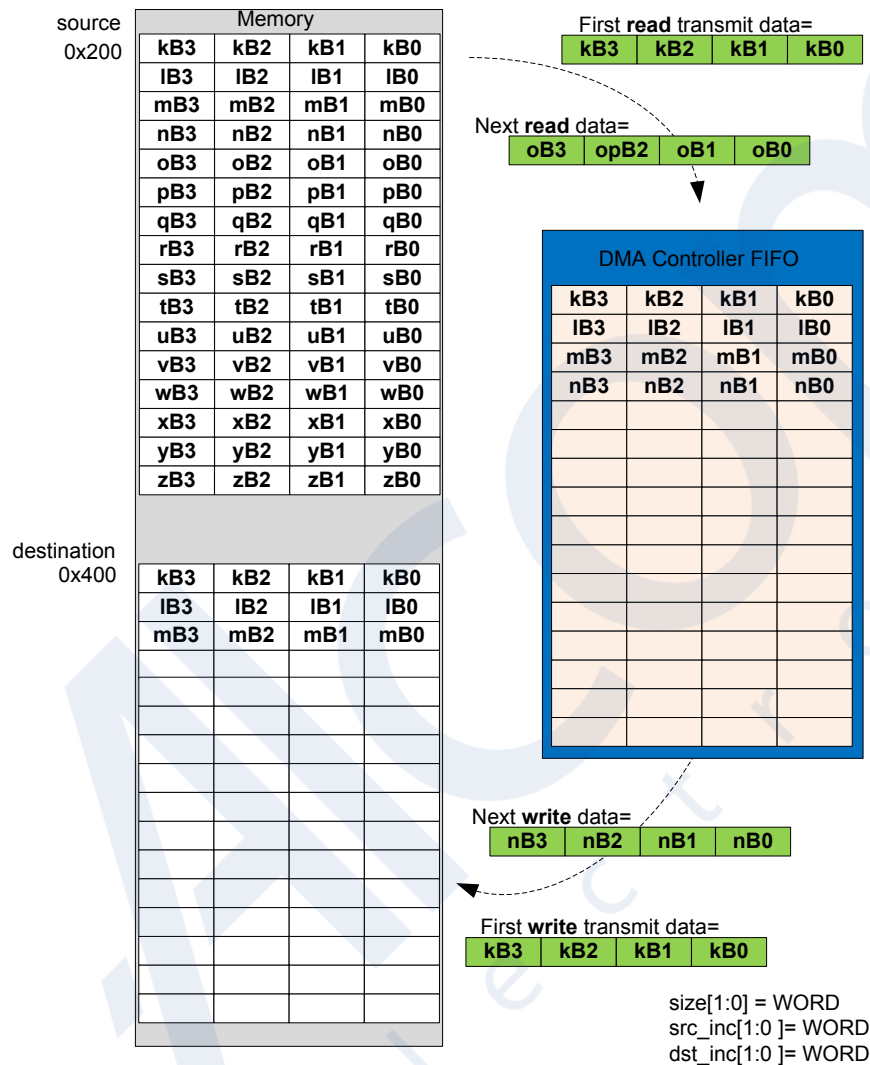

Figure 25.3. Memory-to-Memory Transfer WORD Size Example

The next example shows four variations of half-word sized transfers, with all possible combinations of half- and full-word source and destination increments. Note that when the size and source/destination increments are all configured for half-word, the resulting DMA transfer organization is equivalent to the full-word sized transfer in the previous example. The difference is that the half-word configuration requires twice as many DMA transfers.

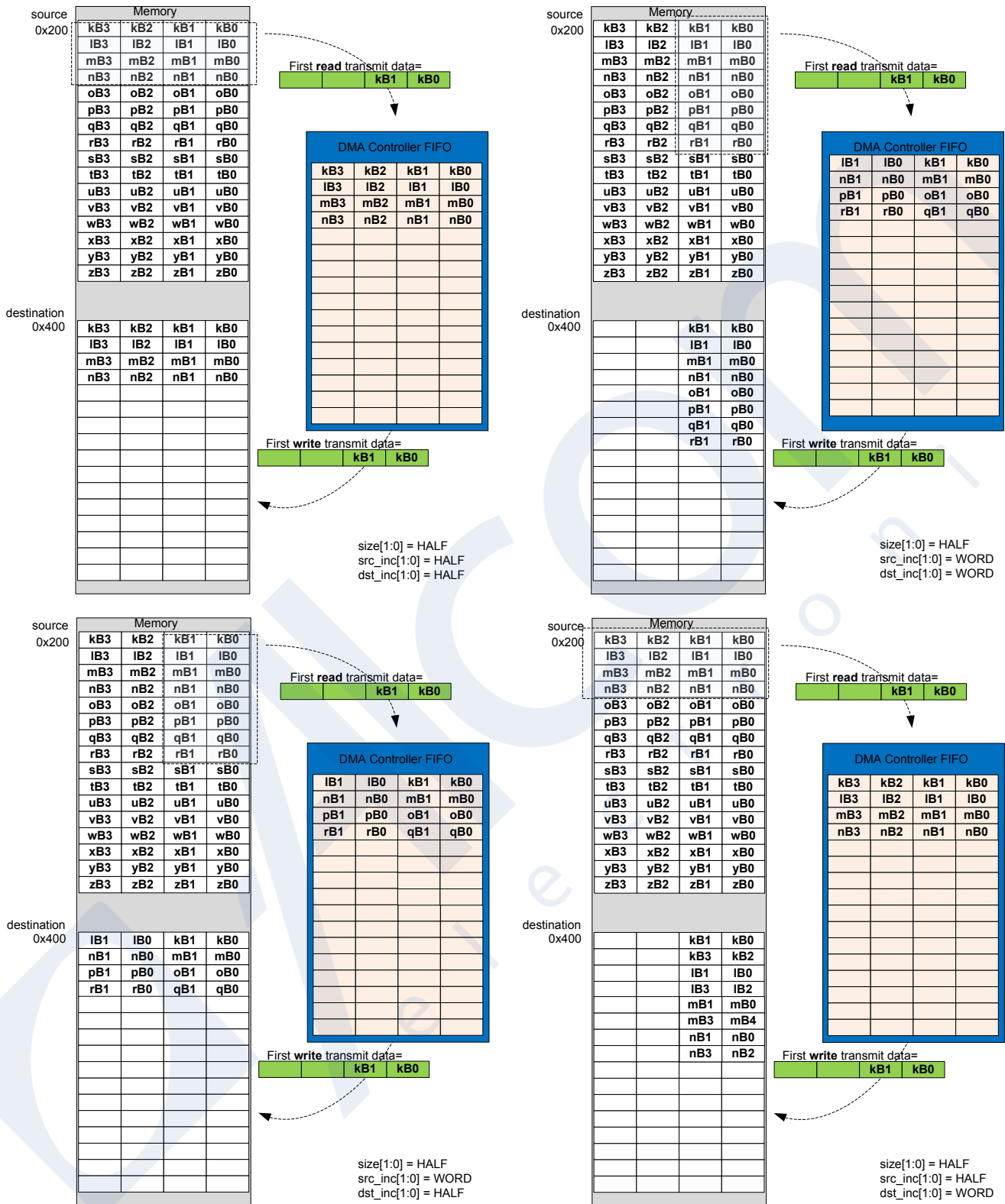

Figure 25.4. Memory-to-Memory Transfer HALF Size Examples

Fields SRCINCSIGN and DSTINCSIGN allow for address decrement. These can be used to mirror an image, for example, in the pixel copy application.

25.3.2 Channel Configuration

Each DMA channel has associated configuration and loop counter registers for controlling direction of address increment, arbitration slots, and descriptor looping.

25.3.2.1 Address Increment/Decrement

Normally DMA transfers increment the source and destination addresses after each DMA transfer. Each channel is also capable of decrementing the source and/or destination addresses after each DMA transfer. This may be useful for flipping an array or copying data from tail to head. For example, a data packet might be prepared as an array of data with increasing addresses and then transmitted from the highest address to the lowest address, from tail to head.

After reset the SRCINCSIGN and DSTINCSIGN bits in the LDMA_CHx_CFG register are cleared causing the source and destination addresses to increment after each transfer. If the SRCINCSIGN bit is set, the DMA will decrement the source address after each transfer. If the DSTINCSIGN bit in the LDMA_CHx_CFG register is set, the DMA will decrement the destination address after each transfer. Setting only one of these bits will flip the data. Setting both bits will copy from tail to head, but will not flip the data.

The SRCINCSIGN and DSTINCSIGN bits apply to all descriptors used by that channel. Software should take care to set the starting source and/or destination address to the highest data address when decrementing.

25.3.2.2 Loop Counter

Each channel has a LDMA_CHx_LOOP register that includes a loop counter field. To use looping, software should initialize the loop counter with the desired number of repetitions before enabling the transfer. A descriptor with the DECLOOPCNT bit set to TRUE will repeat the loop and decrement the loop counter until LOOPCNT = 0.

For a looping descriptor, with DECLOOPCNT=1, the LINK address in the LDMA_CHx_LINK register is used as the loop address. While LOOPCNT is greater than zero, the descriptor will execute and then the LDMA will load the next descriptor using the address specified in the LDMA_CHx_LINK register. This feature enables looping of multiple descriptors. To repeat a single descriptor, the LINK address of the descriptor should point to itself.

After LOOPCNT reaches zero, if the LINK bit in the descriptor LINK word is clear the transfer stops. If the LINK bit is set, the LDMA will load the next sequential descriptor located immediately following the looping descriptor. The behavior of the LINK bit is different for a looping descriptor. This is necessary because the LINK address is re-purposed as the loop address for a looping descriptor.

Note that LOOPCNT sets the number of repeats, not the number of iterations. The total number of loop iterations will be LOOPCNT plus 1. Normally, the LOOPCNT should be set to one or more repeats.

Also note that because there is only one LOOPCNT per channel, software intervention is required to update the LOOPCNT if a sequence of transfers contains multiple loops. It is also possible to use a write immediate DMA data transfer to update the LDMA_CHx_LOOP register.

25.3.3 Channel Select Configuration

The channel select block determines which peripheral request signal connects to each DMA channel.

This configuration is done by software through the SOURCESEL and SIGSEL fields of the LDMA_CHn_REQSEL register. SOURCESEL selects the peripheral and SIGSEL picks which DMA request signals to use from the selected peripheral. Please refer to [25.5 LDMA Source Selection Details](#) for more information.

25.3.4 Starting a Transfer

A transfer may be started by software, a peripheral request, or a descriptor load.

Software may initiate a transfer by setting the bit for the desired channel in the LDMA_SWREQ register. In this case the channel should set SOURCESEL to NONE to prevent unintentional triggering of the channel by a peripheral.

A peripheral may trigger the channel by configuring the peripheral source and signal as described in [25.3.3 Channel Select Configuration](#)

The LDMA may also be configured to begin a transfer immediately after a new descriptor is loaded by setting the STRUCTREQ field of the LDMA_CHx_CTRL register or descriptor word.

This configuration is done by software through the SOURCESEL and SIGSEL fields of the LDMA_CHn_REQSEL register. SOURCESEL selects the peripheral and SIGSEL picks which DMA request signals to use from the selected peripheral.

25.3.4.1 Peripheral Transfer Requests

By default peripherals issue a Single Request (SREQ) when any data is present. For peripherals with a data buffer or FIFO this occurs any time the FIFO is not empty. Upon receiving an SREQ the LDMA will perform one DMA transfer and stop till another request is made.

It is generally more efficient to wait for a peripheral to accumulate data and transfer in a burst. This both reduces overhead of the DMA engine and allows EM2 peripherals to save power by using the LDMA less often. To enable this, set the IGNORESREQ bit in the LDMA_CHx_CTRL register (or descriptor) which will cause the LDMA to ignore SREQs and wait for a full Request (REQ) signal before any data is transferred. For most peripherals with a FIFO the REQ signal is set when the FIFO is full, or a predetermined threshold has been reached. See the individual peripheral chapters for more information.

25.3.5 Managing Transfer Errors

LDMA transfer errors are normally managed using interrupts. Software should clear the ERROR flag in the bit in the LDMA_IF register and enable error interrupts by setting the ERROR bit in the LDMA_IEN register before initiating a DMA transfer.

The LDMA interrupt handler should check the ERROR flag bit in the LDMA_IF register. If the ERROR flag bit is set, it should then read the CHERROR field in the LDMA_STATUS register to determine the errant channel. The interrupt handler should reset the channel and clear the ERROR flag bit in the LDMA_IF register before returning.

25.3.6 Arbitration

While multiple channels are configured simultaneously the LDMA engine can only be actively copying data for one channel at a time. Arbitration determines which channel is being serviced at any point in time. The LDMA will choose a channel through arbitration, transfer BLOCK_SIZE elements of that channel and then arbitrate again choosing another channel to service. This allows high priority channels to be serviced while lower priority channels are in the middle of a transfer.

25.3.6.1 Arbitration Priority

There are two modes in determining priority when the controller arbitrates: fixed priority and round robin priority.

In fixed priority mode, channel 0 has the highest priority. As the channel number increases, the priority decreases. When the LDMA controller is idle or when a transfer completes, the highest priority channel with an active request is granted the transfer. This mode guarantees smallest latency for the highest priority requesters. It is best suited for systems where peak bandwidth is well below LDMA controller's maximum ability to serve. The drawback of this mode is the possibility of starvation for lowest priority requesters.

In the round robin priority mode, each active requesting channel is serviced in the order of priority. A late arriving request on a higher priority channel will not get serviced until the next round. This mode minimizes the risk of starving low-priority latency-tolerant requesters. The drawback of this mode is higher risk of starving low-latency requesters.

The NUMFIXED field in the LDMA_CTRL register determines which channels are fixed priority and which are round robin. Channels lower than NUMFIXED are fixed priority while those above it are round robin. A value of 0x0 implies all channels are round robin. A value of 0x4 implies channels 0 through 3 are fixed priority and 4 through 7 are round robin. A value of 7 implies that channels 0 through 6 are fixed and channel 7 is round robin. This is functionally equivalent to having 8 fixed priority channels.

Fixed priority channels always take priority over round robin. As long as NUMFIXED is greater than 0, there is a possibility that a higher priority channel can starve the remaining channels.

To address the drawbacks of using fixed priority or round robin priority the LDMA implements the concept of arbitration slots. This allows for channels to have high bandwidth and low latency while preventing starvation of latency tolerant low priority channels.

Each channel has a two bit ARBSLOT field in its LDM_CHx_CFG register. This field only applies to channels marked as round robin (determined by NUMFIXED). The channels in the same arbitration slot are treated equally with round robin scheduling. Channels marked with a higher arbitration slot will get serviced more frequently. By default all channels are placed in arbitration slot 1.

Every time the channels in slot 1 get serviced the channels in slot 2 get serviced twice, those in slot 4 get serviced 4 times, and those in slot 8 get serviced 7 times. The specific arbitration allocation can be seen by the following table. The highest arbitration slot is serviced every other arbitration cycle, allowing for low latency response. If there are no requests from channels in arbitration slot then that slot is immediately skipped.

Table 25.1. Arbitration Slot Order

Arbslot order	8	4	8	2	8	4	8	1	8	4	8	2	8	4
Arbslot1								1						
Arbslot2				1								1		
Arbslot4		1				1				1				1
Arbslot8	1		1		1		1		1		1		1	

The top row shows the order at which the arbitration slots are executed. The remaining part of the table shows a more visual interpretation of the arbitration order.

For example, if we have one low latency channel (CHNL0) and two latency tolerant channels (CHNL1 and CHNL2). We could use the following settings.

LDMA_CTRL.NUMFIXED = 0; set round robin for all channels.

CHNL0_CFG.ARBSLOTS = TWO;

CHNL1_CFG.ARBSLOTS = ONE;

CHNL2_CFG.ARBSLOTS = ONE;

If all channels are constantly requesting transfers, then the arbitration order is: CHNL0, CHNL1, CHNL0, CHNL2, CHNL0, CHNL1, CHNL0, CHNL2, CHNL0, etc

Note, there are no channels assigned to arbitration slot four or eight in this example, so those slots are skipped and the final sequence is ARBSLOT2, ARBSLOT1, ARBSLOT2, ARBSLOT1, etc...

Channel 1 and Channel 2 are selected in round robin order when arbitration slot 1 is executed.

If we replace the ARBSLOTS value for channel 0 with EIGHT, then the sequence would look like the following:

CHNL0, CHNL0, CHNL0, CHNL0, CHNL1, CHNL0, CHNL0, CHNL0, CHNL0, CHNL2, CHNL0, CHNL0, CHNL0, CHNL0, CHNL1, etc.

25.3.6.2 DMA Transfer Arbitration

In addition to the inter channel arbitration, software can configure when the controller arbitrates during a DMA transfer. This provides reduced latency to higher priority channels when configuring low priority transfers with more arbitration cycles.

The LDMA provides four bits that configure how many DMA transfers occur before it re-arbitrates. These bits are known as the BLOCKSIZE bits and they map to the arbitration rate as shown below. For example, if BLOCKSIZE = 4 then the arbitration rate is 6, that is, the controller arbitrates every 6 DMA transfers.

Table 25.2 AHB Bus Transfer Arbitration Interval on page 993 lists the arbitration rates.

Table 25.2. AHB Bus Transfer Arbitration Interval

BLOCKSIZE	Arbitrate After x DMA transfers
0	x = 1
1	x = 2
2	x = 3
3	x = 4
4	x = 6
5	x = 8
6	x = 12
7	x = 16
8	x = 24
9	x = 32
10	x = 64
11	x = 128
12	x = 256
13	x = 512
14	x = 1024
15	x = lock

Note: Software must take care not to assign a low-priority channel with a large BLOCKSIZE because this prevents the controller from servicing high-priority requests, until it re-arbitrates.

The number of DMA transfers that need to be done is specified by the user in XFERCNT. When XFERCNT > BLOCKSIZE and is not an integer multiple of BLOCKSIZE then the controller always performs sequences of BLOCKSIZE transfers until XFERCNT < BLOCKSIZE remain to be transferred. The controller performs the remaining XFERCNT transfers at the end of the DMA cycle.

Software must store the value of the BLOCKSIZE bits in the channel control data structure. See 25.3.7.1 XFER Descriptor Structure for more information about the location of the BLOCKSIZE bits in the data structure.

25.3.7 Channel Descriptor Data Structure

Each channel descriptor consists of four 32-bit words:

- CTRL - control word contains information like transfer count and block size.
- SRC - source address points to where to copy data from
- DST - destination address points to where to copy data to
- LINK - link address points to where to load the next linked descriptor

These words map directly to the LDMA_CHx_CTRL, LDMA_CHx_SRC, LDMA_CHx_DST, and LDMA_CHx_LINK registers. The usage of the SRC and DST fields may differ depending on the structure type

There are three different types of descriptor data structures: **XFER**, **SYNC**, and **WRI**

25.3.7.1 XFER Descriptor Structure

This descriptor defines a typical data transfer which may be a Normal, Link, or Loop transfer.

Only this structure type can be written directly into LDMA's registers by the CPU. All descriptors may be linked to. Please refer to the register descriptions for additional information.

For specifying XFER structure type, set STRUCTTYPE to 0. Please see the peripheral register descriptions for information on the fields in this structure.

Name		Bit Position																																		
		31	30	29	28	27	26	25	24	23	22	21	20	19	18	17	16	15	14	13	12	11	10	9	8	7	6	5	4	3	2	1	0			
CTRL	DSTMODE																																			
	SRCMODE																																			
	DSTINC																																			
	SIZE																																			
	SRCINC																																			
	IGNORESREQ																																			
	DECLOOPCNT																																			
	REQMODE																																			
	DONEIFSEN																																			
	BLOCKSIZE																																			
	BYTESWAP																																			
	XFERCNT																																			
	STRUCTREQ																																			
	STRUCTTYPE																																			
DST	SRC	SRCADDR																																		
DST	DST	DSTADDR																																		
LINK	LINK	LINKADDR																																		
	LINKMODE																																			

25.3.7.2 SYNC Descriptor Structure

This descriptor defines an intra-channel synchronizing structure. It allows the channel to wait for some external stimulus before continuing on to the next descriptor. This structure is also used to provide stimulus to another channel to indicate that it may continue.

For example channel 1 may be configured to transfer a header into a buffer while channel 2 is simultaneously transferring data into the same structure. When channel 1 has completed it can wait for a sync signal from channel 2 before transferring the now complete buffer to a peripheral.

Sync descriptors do nothing until a condition is met. The condition is formed by the SYNCTRIG field in the LDMA_SYNC register and the MATCHEN and MATCHVAL fields of the descriptor. When $(\text{SYNCTRIG} \& \text{MATCHEN}) == (\text{MATCHVAL} \& \text{MATCHEN})$ the next descriptor is loaded. In addition to waiting for the condition a Link descriptor can set or clear bits in SYNCTRIG to meet the conditions of another channel and cause it to continue. The CPU also has the ability to set and clear the SYNCTRIG bits from software.

This structure type can only be linked in from memory.

For specifying SYNC structure type, set STRUCTTYPE to 1.

Name	Bit Position																																										
	31	30	29	28	27	26	25	24	23	22	21	20	19	18	17	16	15	14	13	12	11	10	9	8	7	6	5	4	3	2	1	0											
CTRL												DONEIFSEN																	STRUCTTYPE														
													SYNCCLR								SYNCSET																						
DST SRC																												MATCHEN								MATCHVAL							
LINK												LINKADDR																LINK	LINKMODE														

Bit	Name	Description
1:0	STRUCTTYPE	Descriptor Type This field indicates which type of descriptor this is. It must be 1 for a SYNC descriptor.
20	DONEIFSEN	Done if Set indicator If set the interrupt flag will be set when descriptor completes.
15:8	SYNCCLR	Sync Trigger Clear This bit-field is used to clear corresponding bits within the SYNCTRIG field of the SYNC LDMA_SYNC register. To clear a given bit, a one should be loaded to the corresponding bit. Set is given priority over clear if both corresponding bits are loaded with a one. The sync trigger clear function can only be used when loaded from a linked structure. Alternately, the user can directly write the SYNCTRIG bit-field if required.
7:0	SYNCSET	Sync Trigger Set This bit-field is used to set corresponding bits within the SYNCTRIG bit-field. To set a given bit, a one should be loaded to the corresponding bit. Set is given priority over clear if both corresponding bits are loaded with a one. The sync trigger set function can only be used when loaded from a linked structure. Alternately, the user can directly write the SYNCTRIG bit-field if required.
15:8	MATCHEN	Sync Trigger Match Enable This bit-field serves as the SYNCTRIG match enable. A sync match triggers the load of the next linked DMA structure as specified by link_mode, when: $(\text{SYNCTRIG} \& \text{MATCHEN}) == (\text{MATCHVAL} \& \text{MATCHEN})$.
7:0	MATCHVAL	Sync Trigger Match Value

Bit	Name	Description
		This bit-field serves as the SYNCTRIG match value. A sync match triggers the load of the next linked DMA structure as specified by link_mode, when: (SYNCTRIG & MATCHEN) == (MATCHVAL & MATCHEN).

25.3.7.3 WRI Descriptor Structure

This descriptor defines a write-immediate structure. This allows a list of descriptors to write a value to a register or memory location. For example, if a channel wishes to perform two loops in a descriptor sequence a WRI may be used to program the loop count for the second loop.

This structure type can only be linked in from memory.

For specifying WRI structure type, set STRUCTTYPE to 2.

Name	Bit Position																															
	31	30	29	28	27	26	25	24	23	22	21	20	19	18	17	16	15	14	13	12	11	10	9	8	7	6	5	4	3	2	1	0
CTRL												DONEIFSEN																	STRUCTTYPE			
SRC	IMMVAL																															
DST	DSTADDR																															
LINK	LINKADDR																												LINK	LINKMODE		

Bit	Name	Description
1:0	STRUCTTYPE	Descriptor Type This field indicates which type of descriptor this is. It must be 2 for a WRI descriptor.
20	DONEIFSEN	Done if Set indicator If set the interrupt flag will be set when descriptor completes.
31:0	IMMVAL	Immediate Value for Write This bit-field specifies the immediate data value that is to be written to the address pointed to by DSTADDR. Only one write occurs for WRI structures.
31:0	DSTADDR	Address to write This bit-field specifies the address the immediate data should be written to.

25.3.8 Interaction with the EMU

The LDMA interacts with the Energy Management Unit (EMU) to allow transfers from a low energy peripheral while in EM2.

When using the ADC in EM2 or EM3 the EMU can wake up the LDMA as needed to allow data transfers to occur.

25.3.9 Interrupts

The LDMA_IF Interrupt flag register contains one DONE bit for each channel and one combined ERROR bit. When enabled, these interrupts are available as interrupts to the M33 core. They are combined into one interrupt vector, DMA_INT. If the interrupt for the DMA is enabled in the ARM M33 core, an interrupt will be made if one or more of the interrupt flags in LDMA_IF and their corresponding bits in LDMA_IEN are set.

When a descriptor finishes execution the interrupt flag for that channel will be set if the DONEIFSEN field of the LDMA_CHx_LOOP register is set. If LINK and DONEIFSEN are both set when the descriptor completes the interrupt and the linked descriptor will be immediately loaded. When the final descriptor in a linked list (LINK = 0) is finished the interrupt flag is always set regardless of the state of DONEIFSEN.

25.3.10 Debugging

For a peripheral request DMA transfer, if software sets a bit for a channel in the LDMA_DBGHALT register then the DMA will halt during a debug halt and the SRC and DST registers in the debug window will show the transfer in progress. Otherwise, during debug halt the DMA will continue to run and complete the entire transfer causing the descriptor registers to indicate the transfer has completed.

25.4 Examples

This section provides examples of common LDMA usage. All examples assume the LDMA is in the reset state with the channel being configured disabled and LDMA_CHx_CFG, LDMA_CHx_LOOP, and LDMA_CHx_LINK cleared.

25.4.1 Single Direct Register DMA Transfer

This simple example uses only the Channel Descriptor registers directly and does not use linking. Software writes directly to the LDMA channel registers. This example does not use a memory based descriptor list.

This example is suitable for most simple transfers that are limited to transferring one block of data. It supports anything that can be done using a single descriptor. This includes endian conversion and packing/unpacking data. Channel 0 is used for this example.

The LDMA will be used to copy 127 contiguous half words (254 bytes) from 0x0 to 0x1000. It will allow arbitration every 4 transfers and is triggered by a CPU write to the LDMA_SWREQ register. The CH0 interrupt flag will be set when the transfer completes since the descriptor does not link to another descriptor.

- Configure LDMA_CH0_CTRL
 - DSTMODE = 0 (absolute)
 - SRCMODE = 0 (absolute)
 - SIZE = HALFWORD (16 bits)
 - DSTINC = 0 (1 half-word)
 - SRCINC = 0 (1 half-word)
 - DECLOOPCNT=0 (unused)
 - REQMODE = 1 (one request transfers all data)
 - BLOCKSIZE = 3 (4 transfers)
 - BYTESWAP=0 (no byte swap)
 - XFERCNT=127 (transfer 127 half words)
 - STRUCTTYPE=0 (TRANSFER)
- Write source address to LDMA_CH0_SRC register
- Write destination address to LDMA_CH0_DST register
- Configure the LDMA_CH0REQSEL register for the desired peripheral or select none for a memory-to-memory transfer
- Clear and enable interrupts.
 - Write a 1 to bit 0 of the LDMA_IFC register to clear the CH0 DONE flag
 - Write a 1 to bit 0 of the LDMA_IEN register to enable the CH0 interrupt
- Write a 1 to bit 0 of the LDMA_CHEN register to enable CH0

The REQMODE field is normally cleared to zero for a peripheral request transfer and will transfer the specified block size for each peripheral request. The REQMODE may be set to 1 for a memory-to-memory transfer or any time it is desired for a single DMA request to initiate complete transfer.

25.4.2 Descriptor Linked List

This example shows how to use a Linked List of descriptors. Each descriptor has a link address which points to the next descriptor in the list. A descriptor may be removed from the Linked list by altering the Link address of the one before it to point to the one after it. Descriptor Linked lists are useful when handling an array of buffers for communication data. For example, a bad packet can be removed from a receiver queue by simply removing the descriptor from the linked list.

Software loads the first descriptor into the DMA by writing the descriptor address to LDMA_CHx_LINK and setting the bit for that channel in the LDMA_LINKLOAD register. This method is preferred when using a linked list in memory since it treats the first descriptor just like all the others. However, it is also allowed for software to write the first descriptor directly to the LDMA registers.

In this example 4 descriptors are executed in series. the interrupt flag is set after the 2nd and 4th (last) descriptors have completed.

- Prepare a list of descriptors using the XFER structure type in RAM
- Initialize the CTRL, SRC, and DST members as desired
 - Setting STRUCTREQ in the CTRL word for descriptors 2-4 will cause them to begin transferring data as soon as they are loaded.
- Write 0x00000013 to the LINK member of all but the last descriptor
 - LINKMODE = 1 (relative addressing)
 - LINK = 1 (Link to the next descriptor)
 - LINKADDR = 0x00000010 (size of descriptor)
- Set the DONEIFSEN bit in the CTRL member of the 2nd structure so that the interrupt flag will be set when it completes
- Write 0x00000000 to the LINK member of the last descriptor
 - LINK = 0 (Do not link to the next descriptor)
 - LINKMODE = 0 (don't care)
 - LINKADDR = 0x00000000 (don't care)

Each descriptor now points to the start of the next descriptor as shown on the left in [Figure 25.5 Descriptor Linked List on page 998](#). To remove a descriptor from the linked list modify the LINK address of the descriptor of the one before to point to the one after. For example to remove the third descriptor, add 0x00000010 to the LINK register of the second descriptor. The second descriptor will now point to the forth descriptor and skip over the third descriptor as shown on the right in [Figure 25.5 Descriptor Linked List on page 998](#).

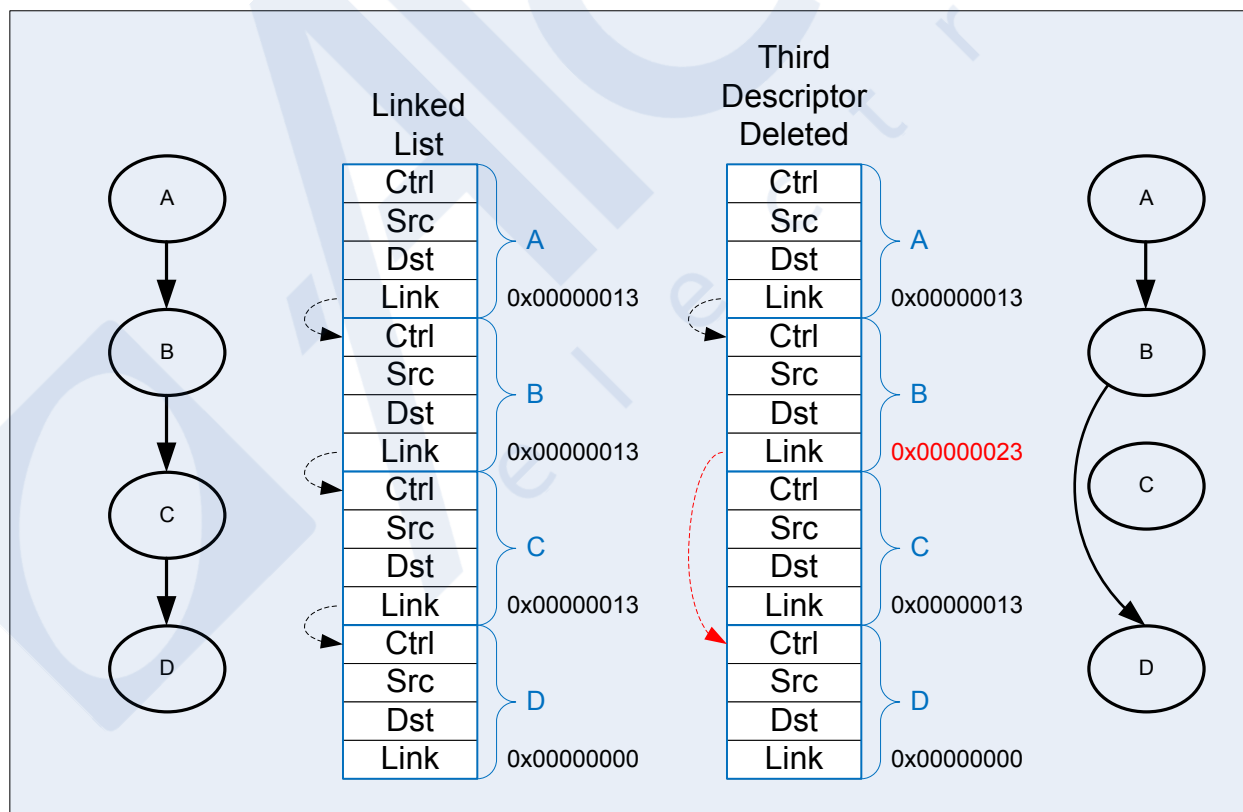

Figure 25.5. Descriptor Linked List

To start execution of the linked list of descriptors:

- Write the absolute address of the first descriptor to the LINKADR field of the LDMA_CH0_LINK register
- Set the LINK bit of LDMA_CH0_LINK register.
- Configure the LDMA_CH0REQSEL register for the desired peripheral or select none for memory-to-memory
- Clear and enable interrupts as desired
- Set bit 0 in the LDMA_LINKLOAD register to initiate loading and execution of the first descriptor

Alternatively, software can manually copy the first descriptor contents to the LDMA_CH0_CTRL, LDMA_CH0_SRC, LDMA_CH0_DST, and LDMA_CH0_LINK registers and then enable the channel in the LDMA_CHEN register.



25.4.3 Single Descriptor Looped Transfer

This example demonstrates how to use looping using a single descriptor. This method allows a single DMA transfer to be repeated a specified number of times. The looping descriptor is stored in memory and reloaded by hardware. After a specified number of iterations, the transfer stops.

CH0 is setup to copy 4 words from the ADC FIFO into a 15 word buffer at 0x1000. It repeats 4 times to fill the entire 16 word buffer. An interrupt will fire when the entire 16 words have been transferred.

Initialize the Linked descriptor in memory as follows:

- Configure CTRL member
 - DSTMODE = 0 (absolute)
 - SRCMODE = 0 (absolute)
 - SIZE = WORD
 - DSTINC = 0 (1 WORD)
 - SRCINC = 3 (0 WORDS)
 - DECLOOPCNT=1 (decrement loop count)
 - REQMODE=1 (Use XFERCNT)
 - BLOCKSIZE = 4 (4 words)
 - BYTESWAP=0 (no swap)
 - XFERCNT= 4 (4 words)
 - STRUCTTYPE=0 (TRANSFER)
 - IGNORESREQ=1 (ignore single requests)
- Write the address ADC0_SINGLEDATA register to the SRC member
- Write 0x1000 address to DST member
- Configure the LINK member
 - LINK = 0 (stop after loop)
 - MODE = 1 (relative link address)
 - LINKADDR = 0 (point to ourself)
- Configure the Channel
 - Write the desired number of repeats to the LDMA_CH0_LOOP register
 - SOURCESEL in LDMA_CH0REQSEL = ADC0 (select the ADC)
 - SIG in LDMA_CH0REQSEL = ADC0SCAN (select the scan conversion request)
- Clear and enable interrupts
- Load the descriptor using LINKLOAD as described in [25.4.2 Descriptor Linked List](#)

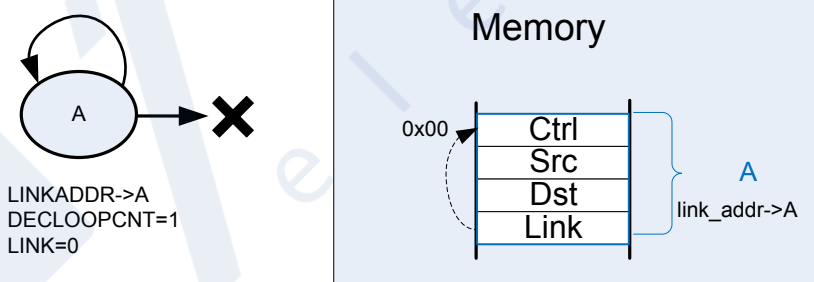

Figure 25.6. Single Descriptor Looped Transfer

Note that the looping descriptor must be stored in memory, because it must load itself from the link address in memory on each iteration.

25.4.4 Descriptor List with Looping

This example uses a descriptor list in memory with looping over multiple descriptors. This example also uses the looping feature and continues on with the next sequential descriptor after looping completes.

The descriptor list in memory is shown in figure [Figure 25.7 Descriptor List with Looping on page 1001](#). Descriptor A links to descriptor B. Descriptor B has the DECLOOPCNT bit enabled and loops back to the start of descriptor A. The LINK address of descriptor B is used for the loop address. The LINK bit is set to indicate that execution will continue after completion of looping. Once the LOOPCNT reaches zero, the LDMA will load descriptor C. Descriptor C must be located immediately following descriptor B.

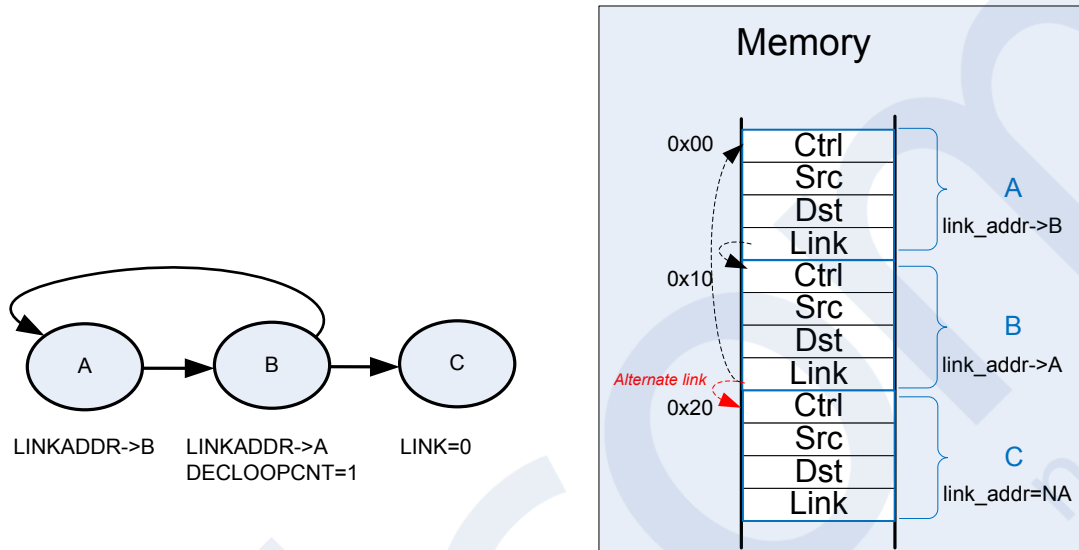

Figure 25.7. Descriptor List with Looping

Initialization is similar to the single looping descriptor with the following modifications.

- Set the LINK bit in descriptors A and B
- write the address of descriptor A into the LIKADDRESS of descriptor B
- write the address of descriptor B into the LIKADDRESS of descriptor A
- Descriptor C must be located immediately after descriptor B in memory

25.4.5 Simple Inter-Channel Synchronization

The LDMA controller features synchronization structures which allow differing channels and/or hardware events to pause a DMA sequence, and wait for a synchronizing event to restart it.

In this example DMA channel 0 and 1 are tasked with the transfer of different sets of data. Channel 0 has two transfer structures, and channel 1 just one, but channel 0 must wait until channel 1 has completed its transfer before it starts its second transfer structure.

Pausing channel 0 is accomplished by inserting a sync wait structure between the two transfer structures. This sync structure waits on SYNCTRIG[7] to be set by a sync set/clear structure which is controlled by channel 1. Sync structures do not transfer data, they can only set, clear, or wait to match the SYNCTRIG[7:0] bits. Note that sync structures cannot decrement loop counter.

```

LDMA_SYNC
  SYNCTRIG=0x0 (at time 0)

LDMA_CH0

  Structure A @ 0x00          Structure B @ 0x10          Structure C @ 0x20
  CTRL                      CTRL                      CTRL
  STRUCTTYPE=XFER          STRUCTTYPE=SYNC          STRUCTTYPE=XFER
  LINK                      LINK                      LINK
  LINKADDR[29:0]=0x00000004 LINKADDR[29:0]=0x00000008 LINKADDR[29:0]=NA
  LINK=1                   LINK=1                   LINK=0

                                DST
                                MATCHEN=0x80
                                MATCHVAL=0x80 (waits for SYNCTRIG[7]=1)

LDMA_CH1

  Structure Y @ 0x30          Structure Z @ 0x40
  CTRL                      CTRL
  STRUCTTYPE=XFER          STRUCTTYPE=SYNC
  LINK                      LINK
  LINKADDR[29:0]=0x00000010 LINKADDR=NA
  LINK=1                   LINK=0

                                SRC
                                SRCCLR=0x0
                                SRCSET=0x80 (sets SYNCTRIG[7])

```

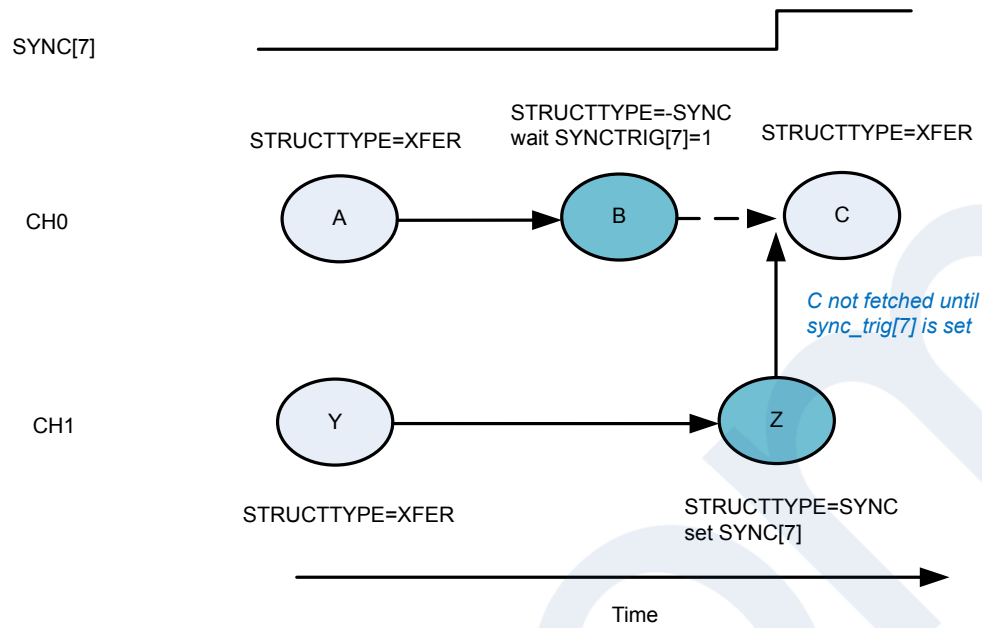

Figure 25.8. Simple Intra-channel Synchronization Example

Both A and Y effectively start at the same time. A finishes earlier, then it links to B, which waits for the SYNC[7] bit to be set before loading C. Y finishes after B is loaded, and it links to sync structure Z, which sets the SYNC[7] bit. Channel 0 responds to the trigger set by loading C for the final data transfer.

25.4.6 2D Copy

The LDMA can easily perform a 2D copy using a descriptor list with looping. This set up is visualized in [Figure 25.9 2D Copy on page 1004](#).

For an application working with graphics, this would mean the ability to copy a rectangle of a given width and height from one picture to another.

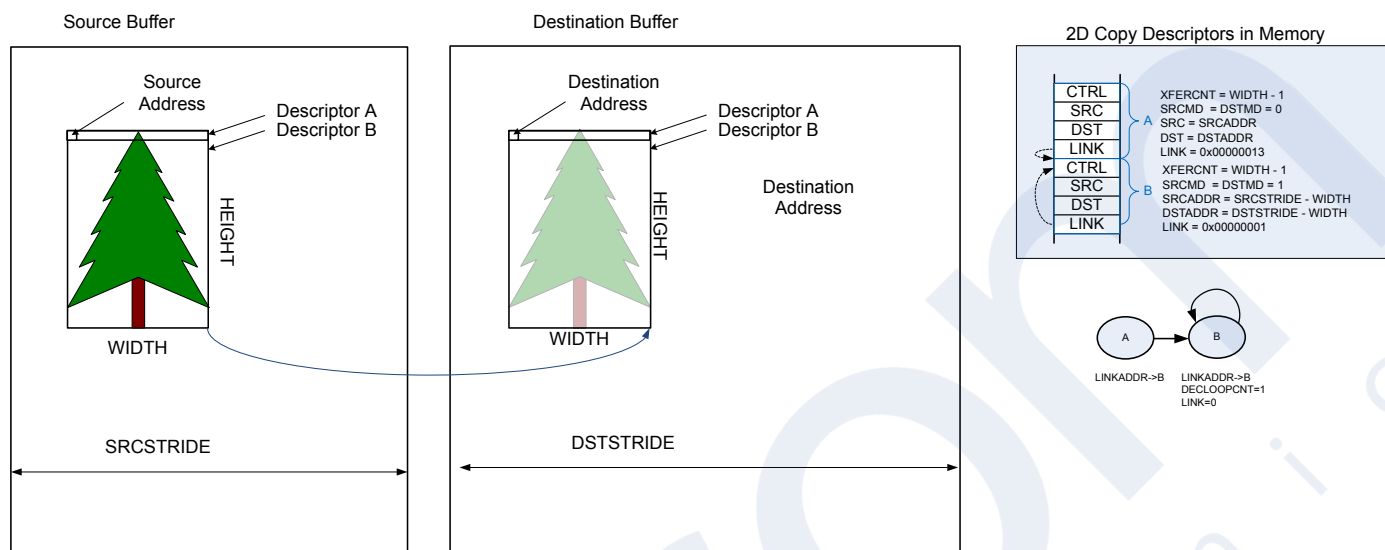

Figure 25.9. 2D Copy

The first descriptor will use absolute addressing mode and the source and destination addresses should point to the desired target addresses. The first descriptor will copy only the first row. The XFERCNT of the first descriptor is set to the desired width minus one.

- CTRL
 - XFERCNT = WIDTH - 1
 - SRCMD = 0 (absolute)
 - DSTMD = 0 (absolute)
- SRCADDR = target source address
- DSTADDR = target destination address
- LINK = 0x00000013
 - LINK=1
 - LINKMD=1
 - LINKADDR=0x00000010 (point to next descriptor)

The second descriptor will use relative addressing and the source and destination addresses are set to the desired offset. After the completion of the first descriptor, the address registers will point to the last address transferred. Thus, the width must be subtracted from the stride to get the offset. The second descriptor uses looping and the link register has not offset.

- CTRL
 - XFERCNT = WIDTH - 1
 - SRCMD = 1 (relative)
 - DSTMD = 1 (relative)
 - DECLOOPCNT = 1
- SRCADDR = desired source offset (SRCSTRIDE-WIDTH)
- DSTADDR = desired destination offset (DSTSTRIDE-WIDTH)
- LINK = 0x00000001
 - LINK=0
 - LINKMD=1 (relative)
 - LINKADDR=0x00000000 (no offset)

Because the first descriptor already transferred one row, the number of looping repeats should be the desired height minus two. Therefore, LOOPCNT should be set to HEIGHT minus two before initiating the transfer.

This same method is easily extended to copy multiple rectangles by linking descriptors together. To initialize the LDMA_CHx_LOOP register, precede each descriptor pair described above with a write immediate descriptor which writes the desired value to the LOOPCNT field of the LDMA_CHx_LOOP register.



25.4.7 Ping-Pong

Communication peripherals often use ping-pong buffers. Ping-pong buffers allow the CPU to process data in one buffer while a peripheral transmits or receives data in the other buffer.

Both transmit and receive ping-pong buffers are easily implemented using the LDMA. In either case, this requires two descriptors as shown in [Figure 25.10 Infinite Ping-Pong Example on page 1006](#). The LINKADDR field of the LINK member should point to the other descriptor. Using two adjacent descriptors and relative link addressing ensures the descriptors are easily reloadable.

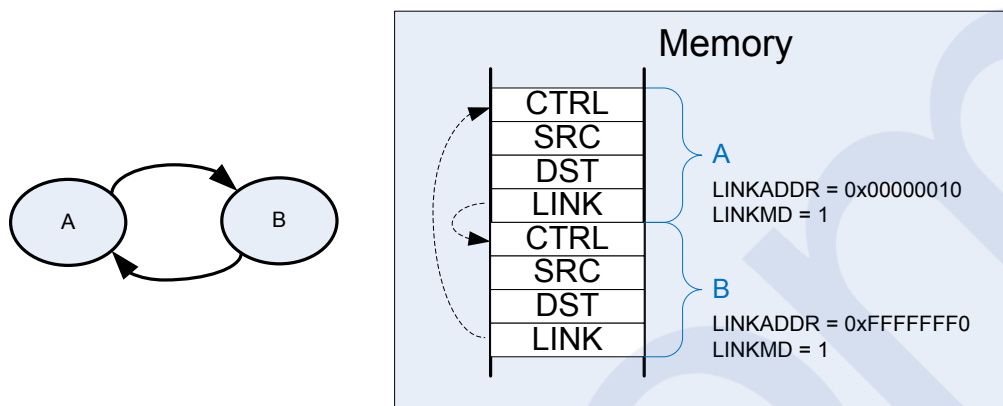

Figure 25.10. Infinite Ping-Pong Example

A **receiver** ping-pong buffer controller consists of two buffers and two descriptors stored in memory that point to the two buffers. Once initialized, as the peripheral receives data, it will fill the first buffer. Once the first buffer is full, it will link automatically to the second buffer and generate an interrupt. Software will then process the data in the first buffer while the LDMA is transferring data to the second buffer. For a receiver ping-pong buffer each descriptor should link to the other descriptor. The link bit should be set to provide infinite ping pong between the two buffers. The DONIFS bit in each descriptor should be set to generate an interrupt on the completion of each descriptor.

- Descriptor A
 - CTRL
 - DONEIFS = 1
 - other settings as desired
 - SRCADDR = peripheral source address
 - DSTADDR = memory destination address
 - LINK = 0x00000013
 - LINKADDR = 0x00000010 (next descriptor)
 - LINK = 1 (link to next descriptor)
 - LINKMD = 1 (relative addressing)
- Descriptor B
 - CTRL
 - DONEIFS = 1
 - other settings as desired
 - SRCADDR = peripheral source address
 - DSTADDR = memory destination address
 - LINK = 0xFFFFFFFF3
 - LINKADDR = 0xFFFFFFFF0 (previous descriptor)
 - LINK = 1 (link to previous descriptor)
 - LINKMD = 1 (relative addressing)

For **transmitter** ping-pong buffer, software will fill the first buffer and then initiate the DMA transfer. The LDMA will transmit the first buffer data while software is filling the second buffer. In this case, the two descriptors should point to each other, but not automatically

continue to the second buffer. The LINK bit should be cleared to zero. Once software has loaded the first buffer, it will use the LINK-LOAD bit to load the first descriptor and transmit the data. The DONIFS need not be set in each descriptor. The DMA will stop and then generate an interrupt at the completion of each descriptor.

- Descriptor A
 - CTRL
 - DONEIFS = 0
 - other settings as desired
 - SRCADDR = memory source address
 - DSTADDR = peripheral destination address
 - LINK = 0x00000013
 - LINKADDR = 0x00000010 (next descriptor)
 - LINK = 0 (link to next descriptor)
 - LINKMD = 1 (relative addressing)
- Descriptor B
 - CTRL
 - DONEIFS = 0
 - other settings as desired
 - SRCADDR = memory source address
 - DSTADDR = peripheral destination address
 - LINK = 0xFFFFFFFF3
 - LINKADDR = 0xFFFFFFFF0 (previous descriptor)
 - LINK = 0 (link to previous descriptor)
 - LINKMD = 1 (relative addressing)

25.4.8 Scatter-Gather

Scatter-Gather in general refers to a process that copies data from multiple locations scattered in memory and gathers the data to a single location in memory, or vice versa. A simple descriptor list allows data gathering. For example, data from a discontinuous list of buffers might be copied to a contiguous sequential array of buffers. The inverse is also possible when a sequential array of buffers is scattered to a discontinuous list of available buffers. See section [25.4.2 Descriptor Linked List](#).

Some DMAs which only have two descriptors implement scatter-gather by using one descriptor to modify the other descriptor. While it is possible to implement this same behavior using the LDMA, it is much more straight-forward to just use a simple descriptor list.

25.5 LDMA Source Selection Details

25.5.1 LDMA Source Selection Details

Table 25.3. LDMA Source Selection Details

SOURCESEL	Source Name	SIGSEL	Request Signal Name
0x1	LDMAXBAR	0x0	LDMAXBARPRSREQ0
		0x1	LDMAXBARPRSREQ1
0x2	TIMER0	0x0	TIMER0CC0
		0x1	TIMER0CC1
		0x2	TIMER0CC2
		0x3	TIMER0UFOF
0x3	TIMER1	0x0	TIMER1CC0
		0x1	TIMER1CC1
		0x2	TIMER1CC2
		0x3	TIMER1UFOF
0x4	USART0	0x0	USART0RXDATAV
		0x1	USART0RXDATAVRIGHT
		0x2	USART0TXBL
		0x3	USART0TXBLRIGHT
		0x4	USART0TXEMPTY
0x5	I2C0	0x0	I2C0RXDATAV
		0x1	I2C0TXBL
0x6	I2C1	0x0	I2C1RXDATAV
		0x1	I2C1TXBL
0xA	IADC0	0x0	IADC0IADC_SCAN
		0x1	IADC0IADC_SINGLE
0xB	MSC	0x0	MSCWDATA
0xC	TIMER2	0x0	TIMER2CC0
		0x1	TIMER2CC1
		0x2	TIMER2CC2
		0x3	TIMER2UFOF
0xD	TIMER3	0x0	TIMER3CC0
		0x1	TIMER3CC1
		0x2	TIMER3CC2
		0x3	TIMER3UFOF
0xE	TIMER4	0x0	TIMER4CC0
		0x1	TIMER4CC1
		0x2	TIMER4CC2
		0x3	TIMER4UFOF

SOURCESEL	Source Name	SIGSEL	Request Signal Name
0xF	EUSART0	0x0	EUSART0RXFL
		0x1	EUSART0TXFL
0x10	EUSART1	0x0	EUSART1RXFL
		0x1	EUSART1TXFL
0x11	VDAC0	0x0	VDAC0CH0_REQ
		0x1	VDAC0CH1_REQ
0x12	VDAC1	0x0	VDAC1CH0_REQ
		0x1	VDAC1CH1_REQ

25.6 LDMA Register Map

The offset register address is relative to the registers base address.

Offset	Name	Type	Description
0x000	LDMA_IPVERSION	R	IP Version
0x004	LDMA_EN	RW	DMA Module Enable Disable Register
0x008	LDMA_CTRL	RW	DMA Control Register
0x00C	LDMA_STATUS	RH	DMA Status Register
0x010	LDMA_SYNCSET	W	DMA Sync Trig Sw Set Register
0x014	LDMA_SYNCCLR	W	DMA Sync Trig Sw Clear Register
0x018	LDMA_SYNCWEN	RW	DMA Sync HW Trigger Enable Register
0x01C	LDMA_SYNCWSEL	RW	DMA Sync HW Trigger Selection Register
0x020	LDMA_SYNCSTATUS	RH	DMA Sync Trigger Status Register
0x024	LDMA_CHEN	W	DMA Channel Enable Register
0x028	LDMA_CHDIS	W	DMA Channel Disable Register
0x02C	LDMA_CHSTATUS	RH	DMA Channel Status Register
0x030	LDMA_CHBUSY	RH	DMA Channel Busy Register
0x034	LDMA_CHDONE	RWH INTFLAG	DMA Channel Linking Done Register
0x038	LDMA_DBGHALT	RW	DMA Channel Debug Halt Register
0x03C	LDMA_SWREQ	W	DMA Channel Software Transfer Request
0x040	LDMA_REQDIS	RW	DMA Channel Request Disable Register
0x044	LDMA_REQPEND	RH	DMA Channel Requests Pending Register
0x048	LDMA_LINKLOAD	W	DMA Channel Link Load Register
0x04C	LDMA_REQCLEAR	W	DMA Channel Request Clear Register
0x050	LDMA_IF	RWH INTFLAG	Interrupt Flag Register
0x054	LDMA_IEN	RW	Interrupt Enable Register
0x05C	LDMA_CHx_CFG	RW	Channel Configuration Register
0x060	LDMA_CHx_LOOP	RWH	Channel Loop Counter Register
0x064	LDMA_CHx_CTRL	RWH	Channel Descriptor Control Word Register
0x068	LDMA_CHx_SRC	RWH	Channel Descriptor Source Address
0x06C	LDMA_CHx_DST	RWH	Channel Descriptor Destination Address
0x070	LDMA_CHx_LINK	RWH	Channel Descriptor Link Address
0x1000	LDMA_IPVERSION_SET	R	IP Version
0x1004	LDMA_EN_SET	RW	DMA Module Enable Disable Register
0x1008	LDMA_CTRL_SET	RW	DMA Control Register
0x100C	LDMA_STATUS_SET	RH	DMA Status Register
0x1010	LDMA_SYNCSET_SET	W	DMA Sync Trig Sw Set Register
0x1014	LDMA_SYNCCLR_SET	W	DMA Sync Trig Sw Clear Register
0x1018	LDMA_SYNCWEN_SET	RW	DMA Sync HW Trigger Enable Register

Offset	Name	Type	Description
0x101C	LDMA_SYNCWSEL_SET	RW	DMA Sync HW Trigger Selection Register
0x1020	LDMA_SYNCSTATUS_SET	RH	DMA Sync Trigger Status Register
0x1024	LDMA_CHEN_SET	W	DMA Channel Enable Register
0x1028	LDMA_CHDIS_SET	W	DMA Channel Disable Register
0x102C	LDMA_CHSTATUS_SET	RH	DMA Channel Status Register
0x1030	LDMA_CHBUSY_SET	RH	DMA Channel Busy Register
0x1034	LDMA_CHDONE_SET	RWH INTFLAG	DMA Channel Linking Done Register
0x1038	LDMA_DBGHALT_SET	RW	DMA Channel Debug Halt Register
0x103C	LDMA_SWREQ_SET	W	DMA Channel Software Transfer Request
0x1040	LDMA_REQDIS_SET	RW	DMA Channel Request Disable Register
0x1044	LDMA_REQPEND_SET	RH	DMA Channel Requests Pending Register
0x1048	LDMA_LINKLOAD_SET	W	DMA Channel Link Load Register
0x104C	LDMA_REQCLEAR_SET	W	DMA Channel Request Clear Register
0x1050	LDMA_IF_SET	RWH INTFLAG	Interrupt Flag Register
0x1054	LDMA_IEN_SET	RW	Interrupt Enable Register
0x105C	LDMA_CHx_CFG_SET	RW	Channel Configuration Register
0x1060	LDMA_CHx_LOOP_SET	RWH	Channel Loop Counter Register
0x1064	LDMA_CHx_CTRL_SET	RWH	Channel Descriptor Control Word Register
0x1068	LDMA_CHx_SRC_SET	RWH	Channel Descriptor Source Address
0x106C	LDMA_CHx_DST_SET	RWH	Channel Descriptor Destination Address
0x1070	LDMA_CHx_LINK_SET	RWH	Channel Descriptor Link Address
0x2000	LDMA_IPVERSION_CLR	R	IP Version
0x2004	LDMA_EN_CLR	RW	DMA Module Enable Disable Register
0x2008	LDMA_CTRL_CLR	RW	DMA Control Register
0x200C	LDMA_STATUS_CLR	RH	DMA Status Register
0x2010	LDMA_SYNCWSEL_CLR	W	DMA Sync Trig Sw Set Register
0x2014	LDMA_SYNCWSEL_CLR	W	DMA Sync Trig Sw Clear Register
0x2018	LDMA_SYNCWEN_CLR	RW	DMA Sync HW Trigger Enable Register
0x201C	LDMA_SYNCWSEL_CLR	RW	DMA Sync HW Trigger Selection Register
0x2020	LDMA_SYNCSTATUS_CLR	RH	DMA Sync Trigger Status Register
0x2024	LDMA_CHEN_CLR	W	DMA Channel Enable Register
0x2028	LDMA_CHDIS_CLR	W	DMA Channel Disable Register
0x202C	LDMA_CHSTATUS_CLR	RH	DMA Channel Status Register
0x2030	LDMA_CHBUSY_CLR	RH	DMA Channel Busy Register
0x2034	LDMA_CHDONE_CLR	RWH INTFLAG	DMA Channel Linking Done Register
0x2038	LDMA_DBGHALT_CLR	RW	DMA Channel Debug Halt Register
0x203C	LDMA_SWREQ_CLR	W	DMA Channel Software Transfer Request

Offset	Name	Type	Description
0x2040	LDMA_REQDIS_CLR	RW	DMA Channel Request Disable Register
0x2044	LDMA_REQPEND_CLR	RH	DMA Channel Requests Pending Register
0x2048	LDMA_LINKLOAD_CLR	W	DMA Channel Link Load Register
0x204C	LDMA_REQCLEAR_CLR	W	DMA Channel Request Clear Register
0x2050	LDMA_IF_CLR	RWH INTFLAG	Interrupt Flag Register
0x2054	LDMA_IEN_CLR	RW	Interrupt Enable Register
0x205C	LDMA_CHx_CFG_CLR	RW	Channel Configuration Register
0x2060	LDMA_CHx_LOOP_CLR	RWH	Channel Loop Counter Register
0x2064	LDMA_CHx_CTRL_CLR	RWH	Channel Descriptor Control Word Register
0x2068	LDMA_CHx_SRC_CLR	RWH	Channel Descriptor Source Address
0x206C	LDMA_CHx_DST_CLR	RWH	Channel Descriptor Destination Address
0x2070	LDMA_CHx_LINK_CLR	RWH	Channel Descriptor Link Address
0x3000	LDMA_IPVERSION_TGL	R	IP Version
0x3004	LDMA_EN_TGL	RW	DMA Module Enable Disable Register
0x3008	LDMA_CTRL_TGL	RW	DMA Control Register
0x300C	LDMA_STATUS_TGL	RH	DMA Status Register
0x3010	LDMA_SYNCSET_TGL	W	DMA Sync Trig Sw Set Register
0x3014	LDMA_SYNCCLR_TGL	W	DMA Sync Trig Sw Clear Register
0x3018	LDMA_SYNCHWEN_TGL	RW	DMA Sync HW Trigger Enable Register
0x301C	LDMA_SYNCHWSEL_TGL	RW	DMA Sync HW Trigger Selection Register
0x3020	LDMA_SYNCSTATUS_TGL	RH	DMA Sync Trigger Status Register
0x3024	LDMA_CHEN_TGL	W	DMA Channel Enable Register
0x3028	LDMA_CHDIS_TGL	W	DMA Channel Disable Register
0x302C	LDMA_CHSTATUS_TGL	RH	DMA Channel Status Register
0x3030	LDMA_CHBUSY_TGL	RH	DMA Channel Busy Register
0x3034	LDMA_CHDONE_TGL	RWH INTFLAG	DMA Channel Linking Done Register
0x3038	LDMA_DBGHALT_TGL	RW	DMA Channel Debug Halt Register
0x303C	LDMA_SWREQ_TGL	W	DMA Channel Software Transfer Request
0x3040	LDMA_REQDIS_TGL	RW	DMA Channel Request Disable Register
0x3044	LDMA_REQPEND_TGL	RH	DMA Channel Requests Pending Register
0x3048	LDMA_LINKLOAD_TGL	W	DMA Channel Link Load Register
0x304C	LDMA_REQCLEAR_TGL	W	DMA Channel Request Clear Register
0x3050	LDMA_IF_TGL	RWH INTFLAG	Interrupt Flag Register
0x3054	LDMA_IEN_TGL	RW	Interrupt Enable Register
0x305C	LDMA_CHx_CFG_TGL	RW	Channel Configuration Register
0x3060	LDMA_CHx_LOOP_TGL	RWH	Channel Loop Counter Register
0x3064	LDMA_CHx_CTRL_TGL	RWH	Channel Descriptor Control Word Register

Offset	Name	Type	Description
0x3068	LDMA_CHx_SRC_TGL	RWH	Channel Descriptor Source Address
0x306C	LDMA_CHx_DST_TGL	RWH	Channel Descriptor Destination Address
0x3070	LDMA_CHx_LINK_TGL	RWH	Channel Descriptor Link Address

25.7 LDMA Register Description

25.7.1 LDMA_IPVERSION - IP Version

Offset	Bit Position																															
0x000	31	30	29	28	27	26	25	24	23	22	21	20	19	18	17	16	15	14	13	12	11	10	9	8	7	6	5	4	3	2	1	0
Reset																																0x0
Access																																R
Name																																IPVERSION

Bit	Name	Reset	Access	Description
31:8	Reserved	To ensure compatibility with future devices, always write Reserved bits to their reset value, unless otherwise stated. More information in 1.2 Conventions		
7:0	IPVERSION	0x0	R	IPVERSION The read only IPVERSION field gives the version for this module. There may be minor software changes required for modules with different values of IPVERSION.

25.7.2 LDMA_EN - DMA Module Enable Disable Register

Offset	Bit Position																															
0x004	31	30	29	28	27	26	25	24	23	22	21	20	19	18	17	16	15	14	13	12	11	10	9	8	7	6	5	4	3	2	1	0
Reset																																0x0
Access																																RW
Name																																EN

Bit	Name	Reset	Access	Description
31:1	Reserved	To ensure compatibility with future devices, always write Reserved bits to their reset value, unless otherwise stated. More information in 1.2 Conventions		
0	EN	0x0	RW	LDMA module enable and disable register The ENABLE bit enables the module. Software should write to CONFIG type registers before setting the ENABLE bit. Software should write to SYNC type registers only after setting the ENABLE bit.

25.7.3 LDMA_CTRL - DMA Control Register

Offset	Bit Position																																
0x008	31	30	29	28	27	26	25	24	23	22	21	20	19	18	17	16	15	14	13	12	11	10	9	8	7	6	5	4	3	2	1	0	
Reset	0x0					0x1E																											
Access	RW					RW																											
Name	CORERST					NUMFIXED																											

Bit	Name	Reset	Access	Description
31	CORERST	0x0	RW	Reset DMA controller Trigger a reset of the LDMA controller core without losing register configuration
30:29	<i>Reserved</i>	<i>To ensure compatibility with future devices, always write Reserved bits to their reset value, unless otherwise stated. More information in 1.2 Conventions</i>		
28:24	NUMFIXED	0x1E	RW	Number of Fixed Priority Channels This field defines the number of Fixed Priority Arbitration channels. Channels CH0 through CH(n-1) are fixed, and channels CH(n) through CH7 are round robin, where n is the field value. The reset value will give all fixed channels.
23:0	<i>Reserved</i>	<i>To ensure compatibility with future devices, always write Reserved bits to their reset value, unless otherwise stated. More information in 1.2 Conventions</i>		

25.7.4 LDMA_STATUS - DMA Status Register

Offset	Bit Position																																			
0x00C	31	30	29	28	27	26	25	24	23	22	21	20	19	18	17	16	15	14	13	12	11	10	9	8	7	6	5	4	3	2	1	0				
Reset	0x8								0x10								0x0								0x0											
Access	R								R								R								R											
Name	CHNUM								FIFOLEVEL								CHERROR								CHGRANT								ANYREQ		ANYBUSY	

Bit	Name	Reset	Access	Description
31:29	Reserved	To ensure compatibility with future devices, always write Reserved bits to their reset value, unless otherwise stated. More information in 1.2 Conventions		
28:24	CHNUM	0x8	R	<p>Number of Channels</p> <p>The value of CHNUM always reads the total number of channels present for this instance of the DMA controller module.</p>
23:21	Reserved	To ensure compatibility with future devices, always write Reserved bits to their reset value, unless otherwise stated. More information in 1.2 Conventions		
20:16	FIFOLEVEL	0x10	R	<p>FIFO Level</p> <p>The value of FIFOLEVEL indicates the number of entries currently in the FIFO. (Note when all channels are disabled, this register will read the total number of entries in the FIFO.)</p>
15:13	Reserved	To ensure compatibility with future devices, always write Reserved bits to their reset value, unless otherwise stated. More information in 1.2 Conventions		
12:8	CHERROR	0x0	R	<p>Errant Channel Number</p> <p>When the ERROR flag is set in the LDMA_IF register, the CHERROR field will indicate the most recent channel to have a transfer error.</p>
7:3	CHGRANT	0x0	R	<p>Granted Channel Number</p> <p>The value of this field indicates the currently active channel or last active channel. Note that the reset value for this field is zero.</p>
2	Reserved	To ensure compatibility with future devices, always write Reserved bits to their reset value, unless otherwise stated. More information in 1.2 Conventions		
1	ANYREQ	0x0	R	<p>Any DMA Channel Request Pending</p> <p>The value of this bit will be TRUE (1) if any requests are pending</p>
0	ANYBUSY	0x0	R	<p>Any DMA Channel Busy</p> <p>The value of this bit will be TRUE (1) if one or more DMA channels are actively transferring data</p>

25.7.5 LDMA_SYNCSET - DMA Sync Trig Sw Set Register

Offset	Bit Position																															
0x010	31	30	29	28	27	26	25	24	23	22	21	20	19	18	17	16	15	14	13	12	11	10	9	8	7	6	5	4	3	2	1	0
Reset																									0x0							
Access																									W							
Name																									SYNCSET							

Bit	Name	Reset	Access	Description
31:8	Reserved			To ensure compatibility with future devices, always write Reserved bits to their reset value, unless otherwise stated. More information in 1.2 Conventions
7:0	SYNCSET	0x0	W	DMA SYNC Software Trigger Set Sets the corresponding bit in the SYNCSTATUS.SYNCTRIG field to value 1.

25.7.6 LDMA_SYNCCLR - DMA Sync Trig Sw Clear Register

Offset	Bit Position																															
0x014	31	30	29	28	27	26	25	24	23	22	21	20	19	18	17	16	15	14	13	12	11	10	9	8	7	6	5	4	3	2	1	0
Reset																									0x0							
Access																									W							
Name																									SYNCCLR							

Bit	Name	Reset	Access	Description
31:8	Reserved			To ensure compatibility with future devices, always write Reserved bits to their reset value, unless otherwise stated. More information in 1.2 Conventions
7:0	SYNCCLR	0x0	W	DMA SYNC Software Trigger Clear Clears the corresponding bit in the SYNCSTATUS.SYNCTRIG field to value 0.

25.7.7 LDMA_SYNCWEN - DMA Sync HW Trigger Enable Register

Offset	Bit Position																															
0x018	31	30	29	28	27	26	25	24	23	22	21	20	19	18	17	16	15	14	13	12	11	10	9	8	7	6	5	4	3	2	1	0
Reset									0x0																0x0							
Access									RW																RW							
Name									SYNCCLREN																SYNCSETEN							

Bit	Name	Reset	Access	Description
31:24	Reserved	To ensure compatibility with future devices, always write Reserved bits to their reset value, unless otherwise stated. More information in 1.2 Conventions		
23:16	SYNCCLREN	0x0	RW	Hardware Sync Trigger Clear Enable Enables the corresponding bit in the SYNCSTATUS.SYNCTRIG field to be cleared by PRS channel 7-0, mapping to bits [23:16].
15:8	Reserved	To ensure compatibility with future devices, always write Reserved bits to their reset value, unless otherwise stated. More information in 1.2 Conventions		
7:0	SYNCSETEN	0x0	RW	Hardware Sync Trigger Set Enable Enables the corresponding bit in the SYNCSTATUS.SYNCTRIG field to be set by PRS channel 7-0, mapping to bits [7:0].

25.7.8 LDMA_SYNCHWSEL - DMA Sync HW Trigger Selection Register

Offset	Bit Position																															
0x01C	31	30	29	28	27	26	25	24	23	22	21	20	19	18	17	16	15	14	13	12	11	10	9	8	7	6	5	4	3	2	1	0
Reset									0x0																0x0							
Access									RW																RW							
Name									SYNCCLREGE																SYNCSETEGE							

Bit	Name	Reset	Access	Description
31:24	<i>Reserved</i>	<i>To ensure compatibility with future devices, always write Reserved bits to their reset value, unless otherwise stated. More information in 1.2 Conventions</i>		
23:16	SYNCCLREGE	0x0	RW	Hardware Sync Trigger Clear Edge Select Select rising or falling edge detection on PRS to clear trigger.
	Value	Mode	Description	
	0	RISE	Use rising edge detection	
	1	FALL	Use falling edge detection	
15:8	<i>Reserved</i>	<i>To ensure compatibility with future devices, always write Reserved bits to their reset value, unless otherwise stated. More information in 1.2 Conventions</i>		
7:0	SYNCSETEGE	0x0	RW	Hardware Sync Trigger Set Edge Select Select rising or falling edge detection on PRS to set trigger.
	Value	Mode	Description	
	0	RISE	Use rising edge detection	
	1	FALL	Use falling edge detection	

25.7.9 LDMA_SYNCSTATUS - DMA Sync Trigger Status Register

Offset	Bit Position																															
0x020	31	30	29	28	27	26	25	24	23	22	21	20	19	18	17	16	15	14	13	12	11	10	9	8	7	6	5	4	3	2	1	0
Reset																									0x0							
Access																									R							
Name																									SYNCTRIG							

Bit	Name	Reset	Access	Description
31:8	Reserved	To ensure compatibility with future devices, always write Reserved bits to their reset value, unless otherwise stated. More information in 1.2 Conventions		
7:0	SYNCTRIG	0x0	R	sync trig status Reflects the status of setting and clearing by software (SYNCSWSET/SYNCSWCLR), hardware (PRS), and loading SYNC structures. Setting a bit always takes precedence over clearing.

25.7.10 LDMA_CHEN - DMA Channel Enable Register

Offset	Bit Position																															
0x024	31	30	29	28	27	26	25	24	23	22	21	20	19	18	17	16	15	14	13	12	11	10	9	8	7	6	5	4	3	2	1	0
Reset																									0x0							
Access																									W							
Name																									CHEN							

Bit	Name	Reset	Access	Description
31:8	Reserved	To ensure compatibility with future devices, always write Reserved bits to their reset value, unless otherwise stated. More information in 1.2 Conventions		
7:0	CHEN	0x0	W	Channel Enables Setting one of these bits will enable the respective DMA channel, writing zeros has no effect

25.7.11 LDMA_CHDIS - DMA Channel Disable Register

Offset	Bit Position																															
0x028	31	30	29	28	27	26	25	24	23	22	21	20	19	18	17	16	15	14	13	12	11	10	9	8	7	6	5	4	3	2	1	0
Reset																									0x0							
Access																									W							
Name																									CHDIS							

Bit	Name	Reset	Access	Description
31:8	Reserved	To ensure compatibility with future devices, always write Reserved bits to their reset value, unless otherwise stated. More information in 1.2 Conventions		
7:0	CHDIS	0x0	W	DMA Channel disable Setting one of these bits will disable the respective DMA channel. Writing zeros has no effect. If set while a transfer is in progress, the current transfer block will complete. The remaining blocks will pause until resumed later by setting corresponding CHEN bit.

25.7.12 LDMA_CHSTATUS - DMA Channel Status Register

Offset	Bit Position																															
0x02C	31	30	29	28	27	26	25	24	23	22	21	20	19	18	17	16	15	14	13	12	11	10	9	8	7	6	5	4	3	2	1	0
Reset																									0x0							
Access																									R							
Name																									CHSTATUS							

Bit	Name	Reset	Access	Description
31:8	Reserved	To ensure compatibility with future devices, always write Reserved bits to their reset value, unless otherwise stated. More information in 1.2 Conventions		
7:0	CHSTATUS	0x0	R	DMA Channel Status The value of this bit will be TRUE (1) if one or more DMA channels are enabled

25.7.13 LDMA_CHBUSY - DMA Channel Busy Register

Offset	Bit Position																															
0x030	31	30	29	28	27	26	25	24	23	22	21	20	19	18	17	16	15	14	13	12	11	10	9	8	7	6	5	4	3	2	1	0
Reset																									0x0							
Access																									R							
Name																									BUSY							

Bit	Name	Reset	Access	Description
31:8	Reserved	To ensure compatibility with future devices, always write Reserved bits to their reset value, unless otherwise stated. More information in 1.2 Conventions		
7:0	BUSY	0x0	R	Channels Busy The bits of this field read 1 when the corresponding channel is busy.

25.7.14 LDMA_CHDONE - DMA Channel Linking Done Register

Offset	Bit Position																																																						
0x034	31	30	29	28	27	26	25	24	23	22	21	20	19	18	17	16	15	14	13	12	11	10	9	8	7	6	5	4	3	2	1	0																							
Reset																									0x0	0x0	0x0	0x0	0x0	0x0	0x0	0x0	0x0	0x0	0x0	0x0	0x0	0x0	0x0	0x0	0x0	0x0	0x0	0x0	0x0	0x0	0x0	0x0	0x0	0x0	0x0	0x0	0x0	0x0	
Access																									RW	RW	RW	RW	RW	RW	RW	RW	RW	RW	RW	RW	RW	RW	RW	RW	RW	RW	RW	RW	RW	RW	RW	RW	RW	RW	RW	RW	RW	RW	RW
Name																									CHDONE7	CHDONE6	CHDONE5	CHDONE4	CHDONE3	CHDONE2	CHDONE1	CHDONE0																							

Bit	Name	Reset	Access	Description
31:8	<i>Reserved</i>			<i>To ensure compatibility with future devices, always write Reserved bits to their reset value, unless otherwise stated. More information in 1.2 Conventions</i>
7	CHDONE7	0x0	RW	DMA Channel Link done intr flag Each DMA channel sets the corresponding bit in this register when the entire linked transfer is done. The interrupt service routine should clear these bits. For non-link structures this will be set once the structure is done.
6	CHDONE6	0x0	RW	DMA Channel Link done intr flag Each DMA channel sets the corresponding bit in this register when the entire linked transfer is done. The interrupt service routine should clear these bits. For non-link structures this will be set once the structure is done.
5	CHDONE5	0x0	RW	DMA Channel Link done intr flag Each DMA channel sets the corresponding bit in this register when the entire linked transfer is done. The interrupt service routine should clear these bits. For non-link structures this will be set once the structure is done.
4	CHDONE4	0x0	RW	DMA Channel Link done intr flag Each DMA channel sets the corresponding bit in this register when the entire linked transfer is done. The interrupt service routine should clear these bits. For non-link structures this will be set once the structure is done.
3	CHDONE3	0x0	RW	DMA Channel Link done intr flag Each DMA channel sets the corresponding bit in this register when the entire linked transfer is done. The interrupt service routine should clear these bits. For non-link structures this will be set once the structure is done.
2	CHDONE2	0x0	RW	DMA Channel Link done intr flag Each DMA channel sets the corresponding bit in this register when the entire linked transfer is done. The interrupt service routine should clear these bits. For non-link structures this will be set once the structure is done.
1	CHDONE1	0x0	RW	DMA Channel Link done intr flag Each DMA channel sets the corresponding bit in this register when the entire linked transfer is done. The interrupt service routine should clear these bits. For non-link structures this will be set once the structure is done.
0	CHDONE0	0x0	RW	DMA Channel Link done intr flag Each DMA channel sets the corresponding bit in this register when the entire linked transfer is done. The interrupt service routine should clear these bits. For non-link structures this will be set once the structure is done.

25.7.15 LDMA_DBGHALT - DMA Channel Debug Halt Register

Offset	Bit Position																															
0x038	31	30	29	28	27	26	25	24	23	22	21	20	19	18	17	16	15	14	13	12	11	10	9	8	7	6	5	4	3	2	1	0
Reset																									0x0							
Access																									RW							
Name																									DBGHALT							

Bit	Name	Reset	Access	Description
31:8	Reserved			To ensure compatibility with future devices, always write Reserved bits to their reset value, unless otherwise stated. More information in 1.2 Conventions
7:0	DBGHALT	0x0	RW	DMA Debug Halt Setting one of these bits will mask the corresponding DMA channel's peripheral request when debugging and the CPU is halted. This may be useful for debugging DMA software.

25.7.16 LDMA_SWREQ - DMA Channel Software Transfer Request

Offset	Bit Position																															
0x03C	31	30	29	28	27	26	25	24	23	22	21	20	19	18	17	16	15	14	13	12	11	10	9	8	7	6	5	4	3	2	1	0
Reset																									0x0							
Access																									W							
Name																									SWREQ							

Bit	Name	Reset	Access	Description
31:8	Reserved			To ensure compatibility with future devices, always write Reserved bits to their reset value, unless otherwise stated. More information in 1.2 Conventions
7:0	SWREQ	0x0	W	Software Transfer Requests Setting one of these bits will trigger a DMA transfer for the corresponding channel. Writing zeros has no effect.

25.7.17 LDMA_REQDIS - DMA Channel Request Disable Register

Offset	Bit Position																															
0x040	31	30	29	28	27	26	25	24	23	22	21	20	19	18	17	16	15	14	13	12	11	10	9	8	7	6	5	4	3	2	1	0
Reset																									0x0							
Access																									RW							
Name																									REQDIS							

Bit	Name	Reset	Access	Description
31:8	Reserved	To ensure compatibility with future devices, always write Reserved bits to their reset value, unless otherwise stated. More information in 1.2 Conventions		
7:0	REQDIS	0x0	RW	DMA Request Disables
Setting one of these bits will disable peripheral requests for the corresponding channel. When cleared any pending peripheral requests will be serviced.				

25.7.18 LDMA_REQPEND - DMA Channel Requests Pending Register

Offset	Bit Position																															
0x044	31	30	29	28	27	26	25	24	23	22	21	20	19	18	17	16	15	14	13	12	11	10	9	8	7	6	5	4	3	2	1	0
Reset																									0x0							
Access																									R							
Name																									REQPEND							

Bit	Name	Reset	Access	Description
31:8	Reserved	To ensure compatibility with future devices, always write Reserved bits to their reset value, unless otherwise stated. More information in 1.2 Conventions		
7:0	REQPEND	0x0	R	DMA Requests Pending
When a DMA channel has a pending peripheral request the corresponding REQPEND bit will read 1.				

25.7.19 LDMA_LINKLOAD - DMA Channel Link Load Register

Offset	Bit Position																															
0x048	31	30	29	28	27	26	25	24	23	22	21	20	19	18	17	16	15	14	13	12	11	10	9	8	7	6	5	4	3	2	1	0
Reset																									0x0							
Access																									W							
Name																									LINKLOAD							

Bit	Name	Reset	Access	Description
31:8	Reserved	To ensure compatibility with future devices, always write Reserved bits to their reset value, unless otherwise stated. More information in 1.2 Conventions		
7:0	LINKLOAD	0x0	W	DMA Link Loads Setting one of these bits will force the corresponding DMA channel to load the next DMA structure and enable the channel. This empowers software to step through a sequence of descriptors.

25.7.20 LDMA_REQCLEAR - DMA Channel Request Clear Register

Offset	Bit Position																															
0x04C	31	30	29	28	27	26	25	24	23	22	21	20	19	18	17	16	15	14	13	12	11	10	9	8	7	6	5	4	3	2	1	0
Reset																									0x0							
Access																									W							
Name																									REQCLEAR							

Bit	Name	Reset	Access	Description
31:8	Reserved	To ensure compatibility with future devices, always write Reserved bits to their reset value, unless otherwise stated. More information in 1.2 Conventions		
7:0	REQCLEAR	0x0	W	DMA Request Clear Setting one of these bits will clear any internally registered transfer requests for the corresponding channel.

25.7.21 LDMA_IF - Interrupt Flag Register

Offset	Bit Position																															
0x050	31	30	29	28	27	26	25	24	23	22	21	20	19	18	17	16	15	14	13	12	11	10	9	8	7	6	5	4	3	2	1	0
Reset	0x0																								0x0	0x0	0x0	0x0	0x0	0x0	0x0	0x0
Access	RW																								RW	RW	RW	RW	RW	RW	RW	RW
Name	ERROR																								DONE7	DONE6	DONE5	DONE4	DONE3	DONE2	DONE1	DONE0

Bit	Name	Reset	Access	Description
31	ERROR	0x0	RW	Error Flag Set to 1 on an Error
30:8	<i>Reserved</i>	<i>To ensure compatibility with future devices, always write Reserved bits to their reset value, unless otherwise stated. More information in 1.2 Conventions</i>		
7	DONE7	0x0	RW	DMA Structure Operation Done When a channel completes a transfer or sync operation, the corresponding DONE bit is set in the LDMA_IF register.
6	DONE6	0x0	RW	DMA Structure Operation Done When a channel completes a transfer or sync operation, the corresponding DONE bit is set in the LDMA_IF register.
5	DONE5	0x0	RW	DMA Structure Operation Done When a channel completes a transfer or sync operation, the corresponding DONE bit is set in the LDMA_IF register.
4	DONE4	0x0	RW	DMA Structure Operation Done When a channel completes a transfer or sync operation, the corresponding DONE bit is set in the LDMA_IF register.
3	DONE3	0x0	RW	DMA Structure Operation Done When a channel completes a transfer or sync operation, the corresponding DONE bit is set in the LDMA_IF register.
2	DONE2	0x0	RW	DMA Structure Operation Done When a channel completes a transfer or sync operation, the corresponding DONE bit is set in the LDMA_IF register.
1	DONE1	0x0	RW	DMA Structure Operation Done When a channel completes a transfer or sync operation, the corresponding DONE bit is set in the LDMA_IF register.
0	DONE0	0x0	RW	DMA Structure Operation Done When a channel completes a transfer or sync operation, the corresponding DONE bit is set in the LDMA_IF register.

25.7.22 LDMA_IEN - Interrupt Enable Register

Offset	Bit Position																																
0x054	31	30	29	28	27	26	25	24	23	22	21	20	19	18	17	16	15	14	13	12	11	10	9	8	7	6	5	4	3	2	1	0	
Reset	0x0																																0x0
Access	RW																																RW
Name	ERROR																																CHDONE

Bit	Name	Reset	Access	Description
31	ERROR	0x0	RW	Enable or disable the error interrupt Enables the AHB bus error interrupt
30:8	<i>Reserved</i>	<i>To ensure compatibility with future devices, always write Reserved bits to their reset value, unless otherwise stated. More information in 1.2 Conventions</i>		
7:0	CHDONE	0x0	RW	Enable or disable the done interrupt Enables done interrupts

25.7.23 LDMA_CHx_CFG - Channel Configuration Register

Offset	Bit Position																																	
0x05C	31	30	29	28	27	26	25	24	23	22	21	20	19	18	17	16	15	14	13	12	11	10	9	8	7	6	5	4	3	2	1	0		
Reset											0x0	0x0					0x0																	
Access											RW	RW					RW																	
Name											DSTINCSIGN	SRCINCSIGN					ARBSLOTS																	

Bit	Name	Reset	Access	Description
31:22	<i>Reserved</i>	<i>To ensure compatibility with future devices, always write Reserved bits to their reset value, unless otherwise stated. More information in 1.2 Conventions</i>		
21	DSTINCSIGN	0x0	RW	Destination Address Increment Sign 0: Increment destination address, 1: Decrement destination address
	Value	Mode	Description	
	0	POSITIVE	Increment destination address	
	1	NEGATIVE	Decrement destination address	
20	SRCINCSIGN	0x0	RW	Source Address Increment Sign 0: Increment source address, 1: Decrement source address
	Value	Mode	Description	
	0	POSITIVE	Increment source address	
	1	NEGATIVE	Decrement source address	
19:18	<i>Reserved</i>	<i>To ensure compatibility with future devices, always write Reserved bits to their reset value, unless otherwise stated. More information in 1.2 Conventions</i>		
17:16	ARBSLOTS	0x0	RW	Arbitration Slot Number Select For channels using round robin arbitration, this bit-field is used to select the number of slots in the round robin queue.
	Value	Mode	Description	
	0	ONE	One arbitration slot selected	
	1	TWO	Two arbitration slots selected	
	2	FOUR	Four arbitration slots selected	
	3	EIGHT	Eight arbitration slots selected	
15:0	<i>Reserved</i>	<i>To ensure compatibility with future devices, always write Reserved bits to their reset value, unless otherwise stated. More information in 1.2 Conventions</i>		

25.7.24 LDMA_CHx_LOOP - Channel Loop Counter Register

Offset	Bit Position																															
0x060	31	30	29	28	27	26	25	24	23	22	21	20	19	18	17	16	15	14	13	12	11	10	9	8	7	6	5	4	3	2	1	0
Reset																									0x0							
Access																									RW							
Name																									LOOPCNT							

Bit	Name	Reset	Access	Description
31:8	Reserved	To ensure compatibility with future devices, always write Reserved bits to their reset value, unless otherwise stated. More information in 1.2 Conventions		
7:0	LOOPCNT	0x0	RW	<p>Linked Structure Sequence Loop Counter</p> <p>This bit-field specifies the number of iterations when using looping descriptors. Software should write to LOOPCNT before using a looping descriptor.</p>

25.7.25 LDMA_CHx_CTRL - Channel Descriptor Control Word Register

Offset	Bit Position																															
0x064	31	30	29	28	27	26	25	24	23	22	21	20	19	18	17	16	15	14	13	12	11	10	9	8	7	6	5	4	3	2	1	0
Reset	0x0	0x0	0x0		0x0		0x0		0x0	0x0	0x0	0x0			0x0		0x0						0x0						0x0			0x0
Access	R	R	RW		RW		RW		RW	RW	RW	RW			RW		RW						RW						R			RW
Name	DSTMODE	SRCMODE	DSTINC		SIZE		SRCINC		IGNORESREQ	DECLOOPCNT	REQMODE	DONEIEN			BLOCKSIZE		BYTESWAP												STRUCTREQ			STRUCTTYPE

Bit	Name	Reset	Access	Description															
31	DSTMODE	0x0	R	Destination Addressing Mode This field specifies the destination addressing mode of linked descriptors. After loading a linked descriptor, reading this field will indicate the destination addressing mode of the linked descriptor. Note that the first descriptor always uses absolute addressing mode. <table border="1"> <thead> <tr> <th>Value</th> <th>Mode</th> <th>Description</th> </tr> </thead> <tbody> <tr> <td>0</td> <td>ABSOLUTE</td> <td>The DSTADDR field of LDMA_CHx_DST contains the absolute address of the destination data.</td> </tr> <tr> <td>1</td> <td>RELATIVE</td> <td>The DSTADDR field of LDMA_CHx_DST contains the relative offset of the destination data.</td> </tr> </tbody> </table>	Value	Mode	Description	0	ABSOLUTE	The DSTADDR field of LDMA_CHx_DST contains the absolute address of the destination data.	1	RELATIVE	The DSTADDR field of LDMA_CHx_DST contains the relative offset of the destination data.						
Value	Mode	Description																	
0	ABSOLUTE	The DSTADDR field of LDMA_CHx_DST contains the absolute address of the destination data.																	
1	RELATIVE	The DSTADDR field of LDMA_CHx_DST contains the relative offset of the destination data.																	
30	SRCMODE	0x0	R	Source Addressing Mode This field specifies the source addressing mode of linked descriptors. After loading a linked descriptor, reading this field will indicate the source addressing mode of the linked descriptor. Note that the first descriptor always uses absolute addressing mode. <table border="1"> <thead> <tr> <th>Value</th> <th>Mode</th> <th>Description</th> </tr> </thead> <tbody> <tr> <td>0</td> <td>ABSOLUTE</td> <td>The SRCADDR field of LDMA_CHx_SRC contains the absolute address of the source data.</td> </tr> <tr> <td>1</td> <td>RELATIVE</td> <td>The SRCADDR field of LDMA_CHx_SRC contains the relative offset of the source data.</td> </tr> </tbody> </table>	Value	Mode	Description	0	ABSOLUTE	The SRCADDR field of LDMA_CHx_SRC contains the absolute address of the source data.	1	RELATIVE	The SRCADDR field of LDMA_CHx_SRC contains the relative offset of the source data.						
Value	Mode	Description																	
0	ABSOLUTE	The SRCADDR field of LDMA_CHx_SRC contains the absolute address of the source data.																	
1	RELATIVE	The SRCADDR field of LDMA_CHx_SRC contains the relative offset of the source data.																	
29:28	DSTINC	0x0	RW	Destination Address Increment Size This bit-field specifies the stride or number of unit data addresses to increment the destination address after each unit of data is transferred. The unit data width is controlled by the SIZE bit-field and can be a byte, half-word or word. <table border="1"> <thead> <tr> <th>Value</th> <th>Mode</th> <th>Description</th> </tr> </thead> <tbody> <tr> <td>0</td> <td>ONE</td> <td>Increment destination address by one unit data size after each write</td> </tr> <tr> <td>1</td> <td>TWO</td> <td>Increment destination address by two unit data sizes after each write</td> </tr> <tr> <td>2</td> <td>FOUR</td> <td>Increment destination address by four unit data sizes after each write</td> </tr> <tr> <td>3</td> <td>NONE</td> <td>Do not increment the destination address. Writes are made to a fixed destination address, for example writing to a FIFO.</td> </tr> </tbody> </table>	Value	Mode	Description	0	ONE	Increment destination address by one unit data size after each write	1	TWO	Increment destination address by two unit data sizes after each write	2	FOUR	Increment destination address by four unit data sizes after each write	3	NONE	Do not increment the destination address. Writes are made to a fixed destination address, for example writing to a FIFO.
Value	Mode	Description																	
0	ONE	Increment destination address by one unit data size after each write																	
1	TWO	Increment destination address by two unit data sizes after each write																	
2	FOUR	Increment destination address by four unit data sizes after each write																	
3	NONE	Do not increment the destination address. Writes are made to a fixed destination address, for example writing to a FIFO.																	

Bit	Name	Reset	Access	Description
27:26	SIZE	0x0	RW	Unit Data Transfer Size This field specifies the size of data transferred.
	Value	Mode		Description
	0	BYTE		Each unit transfer is a byte
	1	HALFWORD		Each unit transfer is a half-word
	2	WORD		Each unit transfer is a word
25:24	SRCINC	0x0	RW	Source Address Increment Size This bit-field specifies the stride or number of unit data addresses to increment the source address after each unit of data is transferred. The unit data width is controlled by the SIZE bit-field and can be a byte, half-word or word.
	Value	Mode		Description
	0	ONE		Increment source address by one unit data size after each read
	1	TWO		Increment source address by two unit data sizes after each read
	2	FOUR		Increment source address by four unit data sizes after each read
	3	NONE		Do not increment the source address. In this mode reads are made from a fixed source address, for example reading FIFO.
23	IGNORESREQ	0x0	RW	Ignore Sreq The channel arbiter will ignore single requests (SREQ) and only respond to multiple requests (REQ) when this bit is set.
22	DECLOOPCNT	0x0	RW	Decrement Loop Count When using looping, setting this bit will decrement the LOOPCNT field in the LDMA_CHx_LOOP register after each descriptor execution.
21	REQMODE	0x0	RW	DMA Request Transfer Mode Select Selects the DMA Request Transfer mode.
	Value	Mode		Description
	0	BLOCK		The LDMA transfers one BLOCKSIZE per transfer request.
	1	ALL		One transfer request transfers all units as defined by the XFRCNT field.
20	DONEIEN	0x0	RW	DMA Operation Done Interrupt Flag Set En Setting this bit will set the interrupt flag when the transfer is done, or linked in the case where the LINK bit is set, or synchronized in the case of a SYNC transfer.
19:16	BLOCKSIZE	0x0	RW	Block Transfer Size This bit-field controls the number of unit data transfers per arbitration cycle
	Value	Mode		Description
	0	UNIT1		One unit transfer per arbitration
	1	UNIT2		Two unit transfers per arbitration
	2	UNIT3		Three unit transfers per arbitration
	3	UNIT4		Four unit transfers per arbitration

Bit	Name	Reset	Access	Description
4		UNIT6		Six unit transfers per arbitration
5		UNIT8		Eight unit transfers per arbitration
7		UNIT16		Sixteen unit transfers per arbitration
9		UNIT32		32 unit transfers per arbitration
10		UNIT64		64 unit transfers per arbitration
11		UNIT128		128 unit transfers per arbitration
12		UNIT256		256 unit transfers per arbitration
13		UNIT512		512 unit transfers per arbitration
14		UNIT1024		1024 unit transfers per arbitration
15		ALL		Transfer all units as specified by the XFRCNT field
15	BYTESWAP	0x0	RW	Endian Byte Swap For word and half-word transfers, setting this bit will swap all bytes of each word or half-word.
14:4	XFRCNT	0x0	RW	DMA Unit Data Transfer Count Specifies number of unit data (words, half-words, or bytes) to transfer, as determined by the SIZE field. The value written should be one less than the desired transfer count.
3	STRUCTREQ	0x0	R	Structure DMA Transfer Request Structure Transfer Request
2	<i>Reserved</i>	<i>To ensure compatibility with future devices, always write Reserved bits to their reset value, unless otherwise stated. More information in 1.2 Conventions</i>		
1:0	STRUCTTYPE	0x0	RW	DMA Structure Type DMA Structure type
	Value	Mode	Description	
	0	TRANSFER	DMA transfer structure type selected.	
	1	SYNCHRONIZE	Synchronization structure type selected.	
	2	WRITE	Write immediate value structure type selected.	

25.7.26 LDMA_CHx_SRC - Channel Descriptor Source Address

Offset	Bit Position																															
0x068	31	30	29	28	27	26	25	24	23	22	21	20	19	18	17	16	15	14	13	12	11	10	9	8	7	6	5	4	3	2	1	0
Reset	0x0																															
Access	RW																															
Name	SRCADDR																															

Bit	Name	Reset	Access	Description
31:0	SRCADDR	0x0	RW	Source Data Address
Writing to this register sets the source address. Reading from this register during a DMA transfer will indicate the next source read address. The value of this register is incremented or decremented with each source read.				

25.7.27 LDMA_CHx_DST - Channel Descriptor Destination Address

Offset	Bit Position																															
0x06C	31	30	29	28	27	26	25	24	23	22	21	20	19	18	17	16	15	14	13	12	11	10	9	8	7	6	5	4	3	2	1	0
Reset	0x0																															
Access	RW																															
Name	DSTADDR																															

Bit	Name	Reset	Access	Description
31:0	DSTADDR	0x0	RW	Destination Data Address
Writing to this register sets the destination address. Reading from this register during a DMA transfer will indicate the next destination write address. This value of this register is incremented or decremented with each destination write.				

25.7.28 LDMA_CHx_LINK - Channel Descriptor Link Address

Offset	Bit Position																															
0x070	31	30	29	28	27	26	25	24	23	22	21	20	19	18	17	16	15	14	13	12	11	10	9	8	7	6	5	4	3	2	1	0
Reset	0x0																												0x0	0x0		
Access	RW																												RW	R		
Name	LINKADDR																												LINK	LINKMODE		

Bit	Name	Reset	Access	Description
31:2	LINKADDR	0x0	RW	Link Structure Address To use linking, write the address of the the first linked descriptor to this register. When a linked descriptor is loaded, it may also be linked to another descriptor. Reading this register will reflect the address of the next linked descriptor.
1	LINK	0x0	RW	Link Next Structure After completing the initial transfer, if this bit is set, the DMA will load the next linked descriptor. If the next linked descriptor also has this bit set, the DMA will load the next linked descriptor.
0	LINKMODE	0x0	R	Link Structure Addressing Mode This field specifies the addressing mode of linked descriptors. After loading a linked descriptor, reading this field will indicate the addressing mode of the loaded linked descriptor. Note that the first descriptor always uses absolute addressing mode.
	Value	Mode	Description	
	0	ABSOLUTE	The LINKADDR field of LDMA_CHx_LINK contains the absolute address of the linked descriptor.	
	1	RELATIVE	The LINKADDR field of LDMA_CHx_LINK contains the relative offset of the linked descriptor.	

25.8 LDMAXBAR Register Map

The offset register address is relative to the registers base address.

Offset	Name	Type	Description
0x000	LDMAXBAR_IPVERSION	R	IP Veersion ID
0x004	LDMAXBAR_CHx_REQSEL	RW	Channel Peripheral Request Select Reg...
0x1000	LDMAXBAR_IPVERSION_SET	R	IP Veersion ID
0x1004	LDMAXBAR_CHx_REQSEL_SET	RW	Channel Peripheral Request Select Reg...
0x2000	LDMAXBAR_IPVERSION_CLR	R	IP Veersion ID
0x2004	LDMAXBAR_CHx_REQSEL_CLR	RW	Channel Peripheral Request Select Reg...
0x3000	LDMAXBAR_IPVERSION_TGL	R	IP Veersion ID
0x3004	LDMAXBAR_CHx_REQSEL_TGL	RW	Channel Peripheral Request Select Reg...

25.9 LDMAXBAR Register Description

25.9.1 LDMAXBAR_IPVERSION - IP Veersion ID

Offset	Bit Position																															
0x000	31	30	29	28	27	26	25	24	23	22	21	20	19	18	17	16	15	14	13	12	11	10	9	8	7	6	5	4	3	2	1	0
Reset																	0x3															
Access																	R															
Name																	IPVERSION															

Bit	Name	Reset	Access	Description
31:0	IPVERSION	0x3	R	IP Version ID ID indicating version of IP

25.9.2 LDMAXBAR_CHx_REQSEL - Channel Peripheral Request Select Reg...

Offset	Bit Position																																					
0x004	31	30	29	28	27	26	25	24	23	22	21	20	19	18	17	16	15	14	13	12	11	10	9	8	7	6	5	4	3	2	1	0						
Reset																	0x0																					
Access																	RW																					
Name																	SOURCESEL																			SIGSEL		

Bit	Name	Reset	Access	Description
31:22	<i>Reserved</i>	<i>To ensure compatibility with future devices, always write Reserved bits to their reset value, unless otherwise stated. More information in 1.2 Conventions</i>		
21:16	SOURCESEL	0x0	RW	Source Select Select input source to DMA channel.
15:4	<i>Reserved</i>	<i>To ensure compatibility with future devices, always write Reserved bits to their reset value, unless otherwise stated. More information in 1.2 Conventions</i>		
3:0	SIGSEL	0x0	RW	Signal Select Select input signal to DMA channel.

26. WDOG - Watch Dog Timer

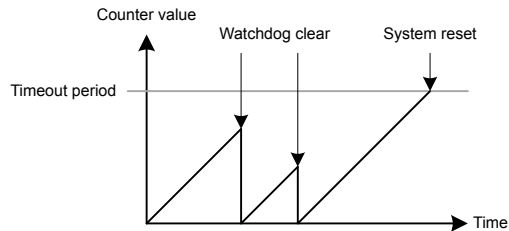
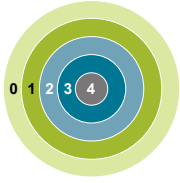

Quick Facts

What?

The WDOG (Watchdog Timer) resets the system in case of a fault condition, and can be enabled in all energy modes as long as the low frequency clock source is available.

Why?

If a software failure or external event renders the MCU unresponsive, a Watchdog timeout will reset the system to a known, safe state.

How?

An enabled Watchdog Timer implements a configurable timeout period. If the CPU fails to re-start the Watchdog Timer before it times out, a full system reset will be triggered. The Watchdog consumes insignificant power, and allows the device to remain safely in low energy modes for up to 256 seconds at a time.

26.1 Introduction

The purpose of the watchdog timer is to generate a reset in case of a system failure to increase application reliability. The failure can be caused by a variety of events, such as an ESD pulse or a software failure.

26.2 Features

- Clock input from selectable oscillators
 - Internal 32 kHz LFRCO oscillator
 - Internal 1 kHz ULFRCO oscillator
 - External 32.768 kHz LFXO XTAL oscillator
 - HCLK divided by 1024
- Configurable timeout period from 9 to 256k watchdog clock cycles
- Individual selection to keep running or freeze when entering EM1 Sleep, EM2 DeepSleep, or EM3 Stop
- Selection to keep running or freeze when entering debug mode
- Selection to block the CPU from entering Energy Mode 4
- Configurable warning interrupt at 25%, 50%, or 75% of the timeout period
- Configurable window interrupt at 12.5%, 25%, 37.5%, 50%, 62.5%, 75%, 87.5% of the timeout period
- Timeout interrupt
- PRS as a watchdog clear
- Interrupt for the event where a PRS rising edge is absent before a software reset

26.3 Functional Description

The watchdog is enabled by setting the EN bit in WDOGn_EN. When enabled, the watchdog counts up to the period value configured through the PERSEL field in WDOGn_CFG. If the watchdog timer is not cleared to 0 (by writing a 1 to the CLEAR bit in WDOGn_CMD) before the period is reached, the chip is reset. If a timely clear command is issued, the timer starts counting up from 0 again. The watchdog can optionally be locked by writing anything other than UNLOCK code in WDOGn_LOCK. Once locked, it cannot be disabled or reconfigured by software.

Note: If the WDOG is configured to halt during EM1, EM2, or EM3 and EM1/EM2/EM3 is entered on the clock cycle before the specified timeout, a timeout event will occur upon the EM1/EM2/EM3 wake event.

When the EN bit in WDOGn_EN is cleared to 0, the watchdog counter is reset. Any pending interrupt flags will remain active until cleared.

26.3.1 Clock Source

Four clock sources are available for use with the watchdog, through the CLKSEL field in CMU_WDOGn_CFG. The selected oscillator source automatically starts when the watchdog is enabled. To prevent accidental change of the clock selection, CMU_WDOGLOCK can be written anything other than UNLOCK code. Also, respective oscillator has locks to prevent accidental disabling of oscillators. The PERSEL field in WDOGn_CFG is used to divide the selected watchdog clock, and the timeout for the watchdog timer can be calculated with the formula:

$$T_{\text{TIMEOUT}} = [2^{(\text{PERSEL}+3)} + 1] / f$$

where f is the frequency of the selected clock.

Users must clear EM2RUN and EM3RUN when the selected clock source is HCLKDIV1024.

26.3.2 Debug Functionality

The watchdog timer can either keep running or be frozen when the device is halted by a debugger. This configuration is done through the DEBUGRUN bit in WDOGn_CFG. When code execution is resumed, the watchdog will continue counting where it left off.

26.3.3 Energy Mode Handling

The watchdog timer can be configured to either keep on running or freeze when entering EM1 Sleep, EM2 DeepSleep, or EM3 Stop. The configuration is done individually for each energy mode in the EM1RUN, EM2RUN, and EM3RUN bits in WDOGn_CFG. When the watchdog has been frozen and is re-entering an energy mode where it is running, the watchdog timer will continue counting where it left off. The watchdog does not run in EM4. If EM4BLOCK in WDOGn_CFG is set, the CPU will be prevented from entering EM4 by software request.

26.3.4 Warning Interrupt

The watchdog implements a warning interrupt which can be configured to occur at approximately 25%, 50%, or 75% of the timeout period through the WARNSEL field of the WDOGn_CFG register. This interrupt can be used to wake up the cpu for clearing the watchdog. The warning point for the watchdog timer can be calculated with the formula:

$$T_{\text{WARNING}} = [2^{(\text{PERSEL}+3)} + 1] * \text{WARNSEL} / 4 / f$$

where f is the frequency of the selected clock.

When the watchdog is enabled, it is recommended to clear the watchdog before changing WARNSEL.

26.3.5 Window Interrupt

This interrupt occurs when the watchdog is cleared below a certain threshold. This threshold is given by the formula:

$$T_{\text{WINDOW}} = [2^{(\text{PERSEL}+3)} + 1] * \text{WARNSEL} / 8 / f$$

where f is the frequency of the selected clock.

This value will be approximately 12.5%, 25%, 37.5%, 50%, 62.5%, 75%, or 87.5% of the timeout value based on the WINSEL field of the WDOGn_CFG. [Figure 26.1 WDOG Warning, Window, and Timeout on page 1038](#) illustrates the warning, the window, and the timeout interrupts. Also, it shows where the PRS rising edge needs to happen. The PRS edge detection feature is discussed later.

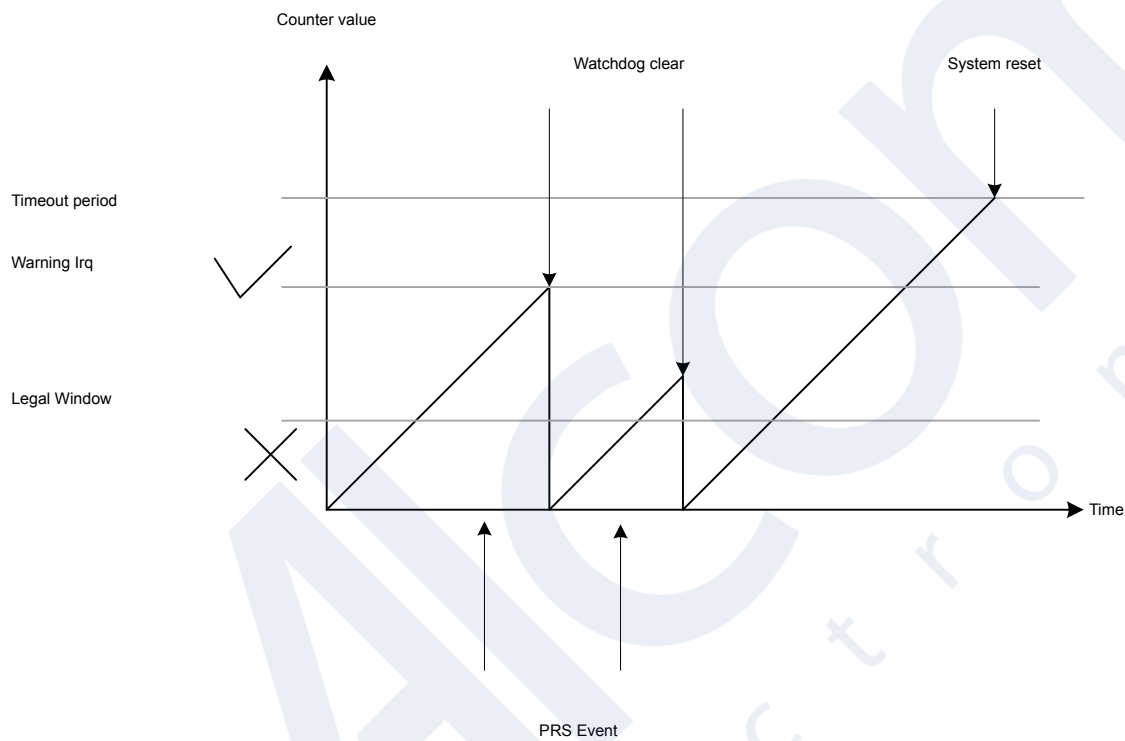

Figure 26.1. WDOG Warning, Window, and Timeout

26.3.6 PRS as Watchdog Clear

A PRS channel (selected by register PRS_CONSUMER_WDOGn_SRC0) can be used to clear the watchdog counter. To enable this feature, CLRSRC must be set to 1. [Figure 26.2 PRS Clearing WDOG on page 1039](#) shows how the PRS channel takes over the WDOG clear function. Clearing the WDOG with the PRS is mutually exclusive of clearing the WDT by software.

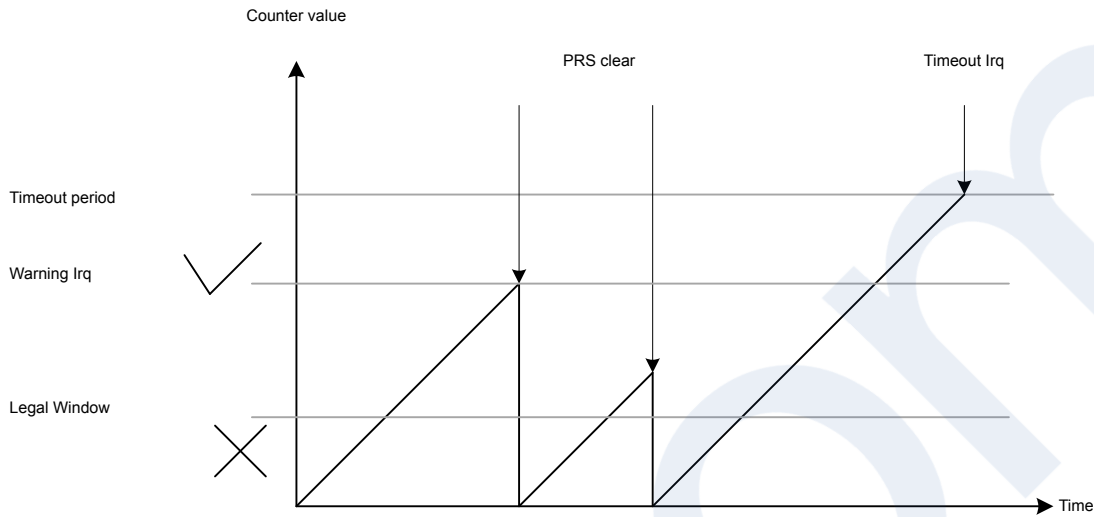

Figure 26.2. PRS Clearing WDOG

26.3.7 PRS Rising Edge Monitoring

PRS channels can be used to monitor multiple processes. The first and second channel are selected by PRS_CONSUMER_WDOGn_SRC0 and PRS_CONSUMER_WDOGn_SRC1, respectively. If enabled, every time the watch dog timer is cleared the PRS channels are checked and any channel which has not seen an event can trigger an interrupt.

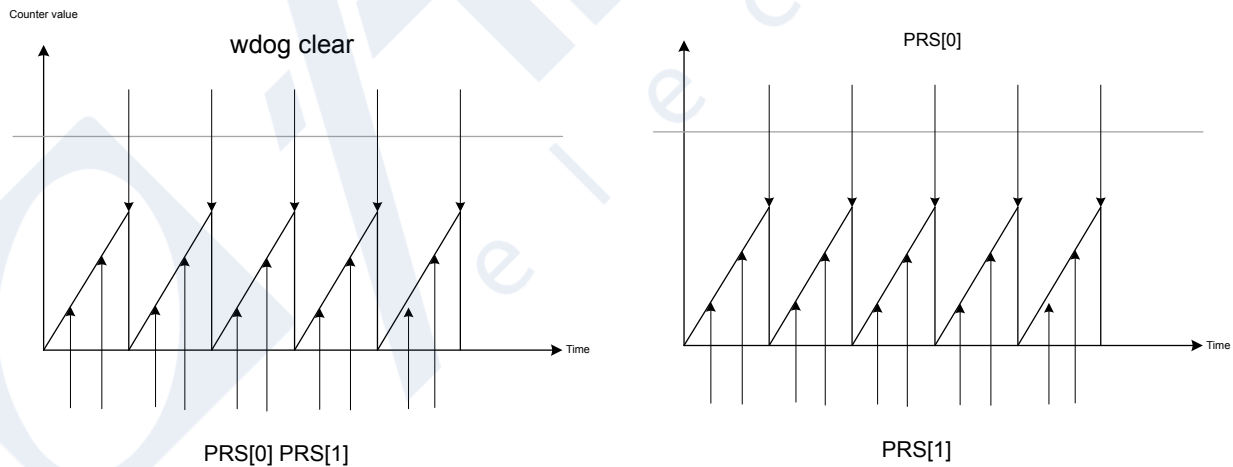

Figure 26.3. PRS Edge Monitoring in WDOG

26.4 WDOG Register Map

The offset register address is relative to the registers base address.

Offset	Name	Type	Description
0x000	WDOG_IPVERSION	R	IP Version Register
0x004	WDOG_EN	RW ENABLE	Enable Register
0x008	WDOG_CFG	RW CONFIG	Configuration Register
0x00C	WDOG_CMD	W LFSYNC	Command Register
0x014	WDOG_STATUS	RH	Status Register
0x018	WDOG_IF	RWH INTFLAG	Interrupt Flag Register
0x01C	WDOG_IEN	RW	Interrupt Enable Register
0x020	WDOG_LOCK	W	Lock Register
0x024	WDOG_SYNCBUSY	RH	Synchronization Busy Register
0x1000	WDOG_IPVERSION_SET	R	IP Version Register
0x1004	WDOG_EN_SET	RW ENABLE	Enable Register
0x1008	WDOG_CFG_SET	RW CONFIG	Configuration Register
0x100C	WDOG_CMD_SET	W LFSYNC	Command Register
0x1014	WDOG_STATUS_SET	RH	Status Register
0x1018	WDOG_IF_SET	RWH INTFLAG	Interrupt Flag Register
0x101C	WDOG_IEN_SET	RW	Interrupt Enable Register
0x1020	WDOG_LOCK_SET	W	Lock Register
0x1024	WDOG_SYNCBUSY_SET	RH	Synchronization Busy Register
0x2000	WDOG_IPVERSION_CLR	R	IP Version Register
0x2004	WDOG_EN_CLR	RW ENABLE	Enable Register
0x2008	WDOG_CFG_CLR	RW CONFIG	Configuration Register
0x200C	WDOG_CMD_CLR	W LFSYNC	Command Register
0x2014	WDOG_STATUS_CLR	RH	Status Register
0x2018	WDOG_IF_CLR	RWH INTFLAG	Interrupt Flag Register
0x201C	WDOG_IEN_CLR	RW	Interrupt Enable Register
0x2020	WDOG_LOCK_CLR	W	Lock Register
0x2024	WDOG_SYNCBUSY_CLR	RH	Synchronization Busy Register
0x3000	WDOG_IPVERSION_TGL	R	IP Version Register
0x3004	WDOG_EN_TGL	RW ENABLE	Enable Register
0x3008	WDOG_CFG_TGL	RW CONFIG	Configuration Register
0x300C	WDOG_CMD_TGL	W LFSYNC	Command Register
0x3014	WDOG_STATUS_TGL	RH	Status Register
0x3018	WDOG_IF_TGL	RWH INTFLAG	Interrupt Flag Register
0x301C	WDOG_IEN_TGL	RW	Interrupt Enable Register
0x3020	WDOG_LOCK_TGL	W	Lock Register

Offset	Name	Type	Description
0x3024	WDOG_SYNCBUSY_TGL	RH	Synchronization Busy Register

26.5 WDOG Register Description

26.5.1 WDOG_IPVERSION - IP Version Register

Offset	Bit Position																															
0x000	31	30	29	28	27	26	25	24	23	22	21	20	19	18	17	16	15	14	13	12	11	10	9	8	7	6	5	4	3	2	1	0
Reset	0x1																															
Access	R																															
Name	IPVERSION																															

Bit	Name	Reset	Access	Description
31:0	IPVERSION	0x1	R	IP Version
The read only IPVERSION field gives the version for this module. There may be minor software changes required for modules with different values of IPVERSION.				

26.5.2 WDOG_EN - Enable Register

Offset	Bit Position																															
0x004	31	30	29	28	27	26	25	24	23	22	21	20	19	18	17	16	15	14	13	12	11	10	9	8	7	6	5	4	3	2	1	0
Reset																															0x0	0x0
Access																															R	RW
Name																															DISABLING	EN

Bit	Name	Reset	Access	Description
31:2	Reserved	To ensure compatibility with future devices, always write Reserved bits to their reset value, unless otherwise stated. More information in 1.2 Conventions		
1	DISABLING	0x0	R	Disabling busy status
When EN is cleared, DISABLING status is set immediately, and cleared when disablement finishes. Disablement resets peripheral cores and not APB registers except hardware updated registers such as INTFLAGS and FIFO				
0	EN	0x0	RW	Module Enable
The ENABLE bit enables the module. Software should write to CONFIG type registers before setting the ENABLE bit. Software should write to SYNC type registers only after setting the ENABLE bit.				

26.5.3 WDOG_CFG - Configuration Register

Offset	Bit Position																																
0x008	31	30	29	28	27	26	25	24	23	22	21	20	19	18	17	16	15	14	13	12	11	10	9	8	7	6	5	4	3	2	1	0	
Reset			0x0				0x0							0xF									0x0	0x0	0x0			0x0	0x0	0x0	0x0	0x0	0x0
Access			RW				RW							RW									RW	RW	RW			RW	RW	RW	RW	RW	RW
Name			WINSEL				WARNSEL							PERSEL									PRSMISSRSTEN	PRSMISSRSTEN	WDOGRSTDIS			DEBUGRUN	EM4BLOCK	EM3RUN	EM2RUN	EM1RUN	CLRSRC

Bit	Name	Reset	Access	Description
31	<i>Reserved</i>			<i>To ensure compatibility with future devices, always write Reserved bits to their reset value, unless otherwise stated. More information in 1.2 Conventions</i>
30:28	WINSEL	0x0	RW	WDOG Illegal Window Select Select WDOG illegal limit.
	Value	Mode		Description
	0	DIS		Disabled.
	1	SEL1		Window timeout is 12.5% of the Timeout.
	2	SEL2		Window timeout is 25% of the Timeout.
	3	SEL3		Window timeout is 37.5% of the Timeout.
	4	SEL4		Window timeout is 50% of the Timeout.
	5	SEL5		Window timeout is 62.5% of the Timeout.
	6	SEL6		Window timeout is 75.5% of the Timeout.
	7	SEL7		Window timeout is 87.5% of the Timeout.
27:26	<i>Reserved</i>			<i>To ensure compatibility with future devices, always write Reserved bits to their reset value, unless otherwise stated. More information in 1.2 Conventions</i>
25:24	WARNSEL	0x0	RW	WDOG Warning Period Select Select WDOG warning timeout period.
	Value	Mode		Description
	0	DIS		Disable
	1	SEL1		Warning timeout is 25% of the Timeout.
	2	SEL2		Warning timeout is 50% of the Timeout.
	3	SEL3		Warning timeout is 75% of the Timeout.
23:20	<i>Reserved</i>			<i>To ensure compatibility with future devices, always write Reserved bits to their reset value, unless otherwise stated. More information in 1.2 Conventions</i>
19:16	PERSEL	0xF	RW	WDOG Timeout Period Select Select WDOG timeout period.

Bit	Name	Reset	Access	Description
	Value	Mode		Description
	0	SEL0		Timeout period of 9 wdog cycles
	1	SEL1		Timeout period of 17 wdog cycles
	2	SEL2		Timeout period of 33 wdog cycles
	3	SEL3		Timeout period of 65 wdog cycles
	4	SEL4		Timeout period of 129 wdog cycles
	5	SEL5		Timeout period of 257 wdog cycles
	6	SEL6		Timeout period of 513 wdog cycles
	7	SEL7		Timeout period of 1k wdog cycles
	8	SEL8		Timeout period of 2k wdog cycles
	9	SEL9		Timeout period of 4k wdog cycles
	10	SEL10		Timeout period of 8k wdog cycles
	11	SEL11		Timeout period of 16k wdog cycles
	12	SEL12		Timeout period of 32k wdog cycles
	13	SEL13		Timeout period of 64k wdog cycles
	14	SEL14		Timeout period of 128k wdog cycles
	15	SEL15		Timeout period of 256k wdog cycles
15:11	<i>Reserved</i>	<i>To ensure compatibility with future devices, always write Reserved bits to their reset value, unless otherwise stated. More information in 1.2 Conventions</i>		
10	PRS1MISSRSTEN	0x0	RW	PRS Src1 Missing Event WDOG Reset When set, a PRS Source 1 missing event will trigger a WDOG reset.
9	PRS0MISSRSTEN	0x0	RW	PRS Src0 Missing Event WDOG Reset When set, a PRS Source 0 missing event will trigger a WDOG reset.
8	WDOGRSTDIS	0x0	RW	WDOG Reset Disable Disable WDOG reset output.
	Value	Mode		Description
	0	EN		A timeout will cause a WDOG reset
	1	DIS		A timeout will not cause a WDOG reset
7:6	<i>Reserved</i>	<i>To ensure compatibility with future devices, always write Reserved bits to their reset value, unless otherwise stated. More information in 1.2 Conventions</i>		
5	DEBUGRUN	0x0	RW	Debug Mode Run Set to keep WDOG running in debug mode.
	Value	Mode		Description
	0	DISABLE		WDOG timer is frozen in debug mode
	1	ENABLE		WDOG timer is running in debug mode
4	EM4BLOCK	0x0	RW	EM4 Block

Bit	Name	Reset	Access	Description
	Set to disallow EM4 entry by software.			
	Value	Mode		Description
	0	DISABLE		EM4 can be entered by software. See EMU for detailed description.
	1	ENABLE		EM4 cannot be entered by software.
3	EM3RUN	0x0	RW	EM3 Run
	Set to keep WDOG running in EM3.			
	Value	Mode		Description
	0	DISABLE		WDOG timer is frozen in EM3.
	1	ENABLE		WDOG timer is running in EM3.
2	EM2RUN	0x0	RW	EM2 Run
	Set to keep WDOG running in EM2.			
	Value	Mode		Description
	0	DISABLE		WDOG timer is frozen in EM2.
	1	ENABLE		WDOG timer is running in EM2.
1	EM1RUN	0x0	RW	EM1 Run
	Set to keep WDOG running in EM1.			
	Value	Mode		Description
	0	DISABLE		WDOG timer is frozen in EM1.
	1	ENABLE		WDOG timer is running in EM1.
0	CLRSRC	0x0	RW	WDOG Clear Source
	Select WDOG clear source.			
	Value	Mode		Description
	0	SW		A write to the clear bit will clear the WDOG counter
	1	PRSSRC0		A rising edge on the PRS Source 0 will clear the WDOG counter

26.5.4 WDOG_CMD - Command Register

Offset	Bit Position																															
0x00C	31	30	29	28	27	26	25	24	23	22	21	20	19	18	17	16	15	14	13	12	11	10	9	8	7	6	5	4	3	2	1	0
Reset																																0x0
Access																																W(nB)
Name																																CLEAR

Bit	Name	Reset	Access	Description
31:1	Reserved	<i>To ensure compatibility with future devices, always write Reserved bits to their reset value, unless otherwise stated. More information in 1.2 Conventions</i>		
0	CLEAR	0x0	W(nB)	WDOG Timer Clear Clear WDOG timer. The bit must be written 4 WDOG cycles before the timeout.
	Value	Mode	Description	
	0	UNCHANGED	WDOG timer is unchanged.	
	1	CLEARED	WDOG timer is cleared to 0.	

26.5.5 WDOG_STATUS - Status Register

Offset	Bit Position																															
0x014	31	30	29	28	27	26	25	24	23	22	21	20	19	18	17	16	15	14	13	12	11	10	9	8	7	6	5	4	3	2	1	0
Reset	0x0																															
Access	R																															
Name	LOCK																															

Bit	Name	Reset	Access	Description
31	LOCK	0x0	R	WDOG Configuration Lock Status Status of all lockable WDOG registers.
	Value	Mode	Description	
	0	UNLOCKED	All WDOG lockable registers are unlocked.	
	1	LOCKED	All WDOG lockable registers are locked.	
30:0	Reserved	<i>To ensure compatibility with future devices, always write Reserved bits to their reset value, unless otherwise stated. More information in 1.2 Conventions</i>		

26.5.6 WDOG_IF - Interrupt Flag Register

Offset	Bit Position																															
0x018	31	30	29	28	27	26	25	24	23	22	21	20	19	18	17	16	15	14	13	12	11	10	9	8	7	6	5	4	3	2	1	0
Reset																											0x0	0x0	0x0	0x0	0x0	
Access																											RW	RW	RW	RW	RW	
Name																											PEM1	PEM0	WIN	WARN	TOUT	

Bit	Name	Reset	Access	Description
31:5	<i>Reserved</i>	<i>To ensure compatibility with future devices, always write Reserved bits to their reset value, unless otherwise stated. More information in 1.2 Conventions</i>		
4	PEM1	0x0	RW	PRS Src1 Event Missing Interrupt Flag Set when a WDOG clear happens before a prs event has been detected on PRS Source one.
3	PEM0	0x0	RW	PRS Src0 Event Missing Interrupt Flag Set when a WDOG clear happens before a prs event has been detected on PRS Source zero.
2	WIN	0x0	RW	WDOG Window Interrupt Flag Set when a WDOG clear happens below the window limit value.
1	WARN	0x0	RW	WDOG Warning Timeout Interrupt Flag Set when a WDOG warning timeout has occurred.
0	TOUT	0x0	RW	WDOG Timeout Interrupt Flag Set when a WDOG timeout has occurred.

26.5.7 WDOG_IEN - Interrupt Enable Register

Offset	Bit Position																															
0x01C	31	30	29	28	27	26	25	24	23	22	21	20	19	18	17	16	15	14	13	12	11	10	9	8	7	6	5	4	3	2	1	0
Reset																											0x0	0x0	0x0	0x0	0x0	
Access																											RW	RW	RW	RW	RW	
Name																											PEM1	PEM0	WIN	WARN	TOUT	

Bit	Name	Reset	Access	Description
31:5	<i>Reserved</i>	<i>To ensure compatibility with future devices, always write Reserved bits to their reset value, unless otherwise stated. More information in 1.2 Conventions</i>		
4	PEM1	0x0	RW	PRS Src1 Event Missing Interrupt Enable Enable/disable the PEM1 interrupt.
3	PEM0	0x0	RW	PRS Src0 Event Missing Interrupt Enable Enable/disable the PEM0 interrupt.
2	WIN	0x0	RW	WDOG Window Interrupt Enable Enable/disable the WIN interrupt.
1	WARN	0x0	RW	WDOG Warning Timeout Interrupt Enable Enable/disable the WARN interrupt.
0	TOUT	0x0	RW	WDOG Timeout Interrupt Enable Enable/disable the TOUT interrupt.

26.5.8 WDOG_LOCK - Lock Register

Offset	Bit Position																															
0x020	31	30	29	28	27	26	25	24	23	22	21	20	19	18	17	16	15	14	13	12	11	10	9	8	7	6	5	4	3	2	1	0
Reset																	0xABE8															
Access																	W															
Name																	LOCKKEY															

Bit	Name	Reset	Access	Description
31:16	Reserved	To ensure compatibility with future devices, always write Reserved bits to their reset value, unless otherwise stated. More information in 1.2 Conventions		
15:0	LOCKKEY	0xABE8	W	WDOG Configuration Lock Write any other value than the unlock code to lock WDOG_EN, WDOD_CFG registers from editing. Write the unlock code to unlock.
	Value	Mode	Description	
	0	LOCK	Lock WDOG lockable registers	
	44008	UNLOCK	Unlock WDOG lockable registers	

26.5.9 WDOG_SYNCBUSY - Synchronization Busy Register

Offset	Bit Position																															
0x024	31	30	29	28	27	26	25	24	23	22	21	20	19	18	17	16	15	14	13	12	11	10	9	8	7	6	5	4	3	2	1	0
Reset																																0x0
Access																																R
Name																																CMD

Bit	Name	Reset	Access	Description
31:1	Reserved	To ensure compatibility with future devices, always write Reserved bits to their reset value, unless otherwise stated. More information in 1.2 Conventions		
0	CMD	0x0	R	Sync Busy for Cmd Register CMD bitfield sync is busy when set.

27. PCNT - Pulse Counter

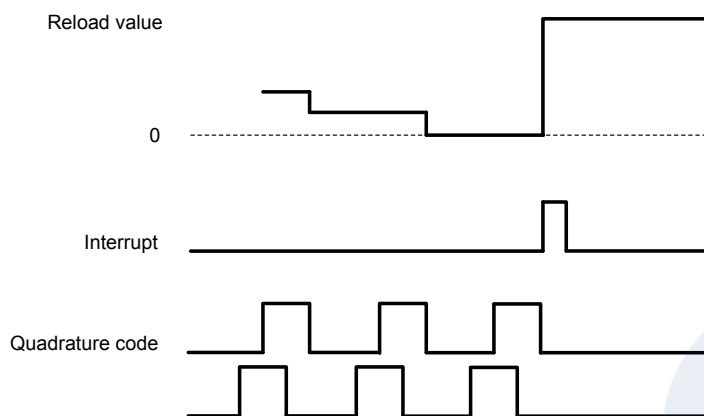
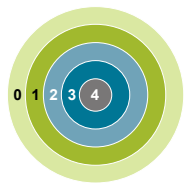

Quick Facts

What?

The Pulse Counter (PCNT) decodes incoming pulses. The module has a quadrature mode which may be used to decode the speed and direction of a mechanical shaft. PCNT can operate in EM0 down to EM3.

Why?

The PCNT generates an interrupt after a specific number of pulses (or rotations), eliminating the need for timing or I/O interrupts and CPU processing to measure pulse widths, etc.

How?

PCNT uses the EM23GRPACLK or may be externally clocked from a pin. The module incorporates a 16-bit up/down-counter to keep track of incoming pulses or rotations.

27.1 Introduction

The Pulse Counter (PCNT) can be used for counting incoming pulses on a single input or to decode quadrature encoded inputs in EM0 down to EM3. It can run from the internal EM23GRPACLK clock source while counting pulses on the PCNTn_S0IN pin. Alternatively, the PCNTn_S0IN pin or a PRS signal may be used as an external clock source that runs the PCNT counter and register access.

27.2 Features

- 16-bit counter with reload register
- Auxiliary counter for counting a single direction
- Single input oversampling up/down counter mode
- Externally clocked single input pulse up/down counter mode
- Quadrature decoder modes
 - Externally clocked quadrature decoder 1X mode
 - Oversampling quadrature decoder 1X, 2X and 4X modes
- Interrupt on counter underflow and overflow
- Interrupt when a direction change is detected (quadrature decoder mode only)
- Optional pulse width filter
- Optional input inversion/edge detect select
- Optional inputs from PRS

27.3 Functional Description

An overview of the PCNT module is shown in [Figure 27.1 PCNT Overview on page 1050](#).

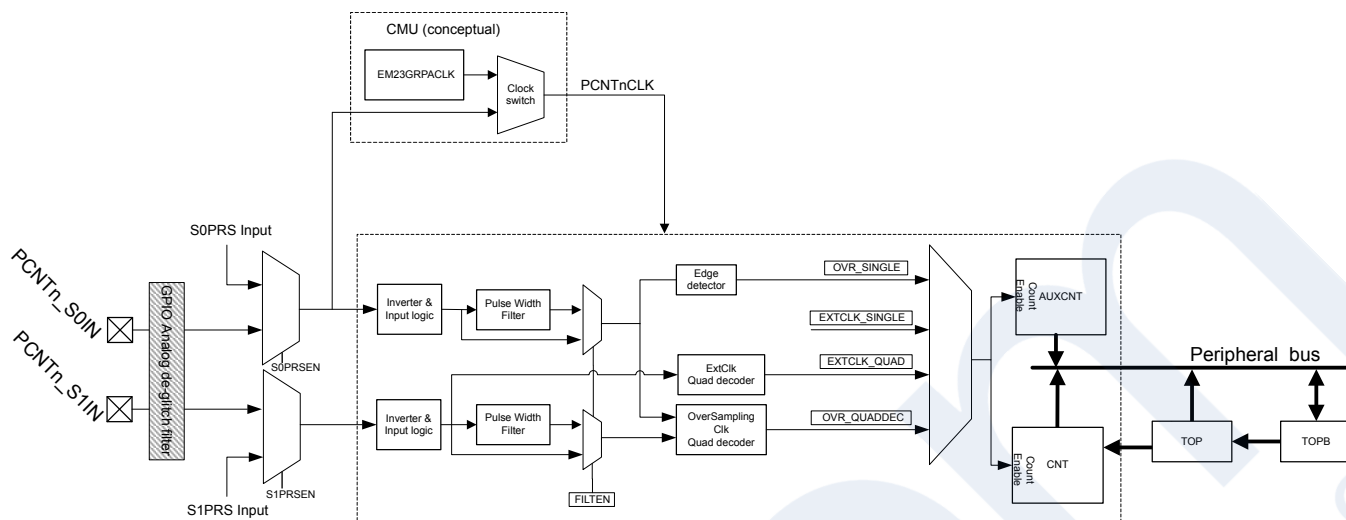

Figure 27.1. PCNT Overview

27.3.1 Pulse Counter Modes

The pulse counter can operate in single input oversampling mode (OVSSINGLE), externally clocked single input counter mode (EXTCLKSINGLE), externally clocked quadrature decoder mode (EXTCLKQUAD) and oversampling quadrature decoder modes (OVSQUAD1X, OVSQUAD2X and OVSQUAD4X). The following sections describe operation of each of these modes and how they are enabled.

27.3.1.1 Single Input Oversampling Mode

This mode is selected by writing OVSSINGLE to the MODE field in the PCNTn_CFG register. The STARTCNT bit in PCNTn_CMD is used to start the counter, and STOPCNT can be used to stop the counter. The EM23GRPACLK clock source to the pulse counter is selected by setting CLKSEL in the CMU_PCNT0CLKCTRL register to EM23GRPACLK. In this mode the maximum input toggle frequency should be 2 times slower than the frequency of the selected EM23GRPACLK clock source.

The optional pulse width filter is enabled by setting the FILTEN bit in the PCNTn_CFG register. Additionally, the PCNTn_S0IN input may be inverted, so that falling edges are counted, by setting the EDGE bit in the PCNTn_CTRL register.

If S1CDIR in the PCNTn_CTRL register is cleared, PCNTn_S0IN is the only observed input in this mode. The PCNTn_S0IN input is sampled by the PCNTnCLK and the number of detected positive or negative edges on PCNTn_S0IN appears in PCNTn_CNT. By default the counter will count up, but the counter may be configured to count down by setting the CNTDIR bit in PCNTn_CTRL.

The counting direction can also be controlled externally in this mode, by setting S1CDIR. This will make the input value on PCNTn_S1IN decide the direction counted for each PCNTn_S0IN edge. When PCNTn_S1IN is high, the count is done according to CNTDIR in PCNTn_CTRL. When PCNTn_S1IN is low, the count direction is opposite.

27.3.1.2 Externally Clocked Single Input Counter Mode

This mode is enabled by writing EXTCLKSINGLE to the MODE field in the PCNTn_CFG register. The STARTCNT bit in PCNTn_CMD is used to start the counter, and STOPCNT can be used to stop the counter. The external pin clock source is selected by setting CLKSEL in the CMU_PCNT0CLKCTRL register to PCNTS0.

Positive edges on PCNTn_S0IN are used to clock the counter. Similar to the oversampled mode, PCNTn_S1IN is used to determine the count direction if S1CDIR is set. If not, CNTDIR in PCNTn_CTRL solely defines count direction.

The digital pulse width filter is not available in this mode. The analog de-glitch filter in the GPIO pads is capable of removing some unwanted noise. However, this mode may be susceptible to spikes and unintended pulses from devices such as mechanical switches, and is therefore most suited to take input from electronic sensors etc. that generate single wire pulses.

27.3.1.3 Quadrature Decoder Modes

Two different types of quadrature decoding are supported in the pulse counter: the externally clocked (Asynchronous) quadrature decoding and the oversampling (Synchronous) quadrature decoding. The externally clocked mode supports 1X quadrature decoding whereas the oversampling mode supports 1X, 2X and 4X quadrature decoding. These modes are described in detail in [27.3.1.4 Externally Clocked Quadrature Decoder Mode](#) and [27.3.1.5 Oversampling Quadrature Decoder Mode](#) .



27.3.1.4 Externally Clocked Quadrature Decoder Mode

This mode is enabled by writing EXTCLKQUAD to the MODE field in PCNTn_CFG. The STARTCNT bit in PCNTn_CMD is used to start the counter, and STOPCNT can be used to stop the counter. The external pin clock source is selected by setting CLKSEL in the CMU_PCNT0CLKCTRL register to PCNTS0.

In this mode, both edges on PCNTn_S0IN pin are used to sample the PCNTn_S1IN pin, in order to decode the quadrature code. A quadrature coded signal contains information about the relative speed and direction of a rotating shaft as illustrated by [Figure 27.2 PCNT Quadrature Coding on page 1052](#), hence the direction of the counter register PCNTn_CNT is controlled automatically.

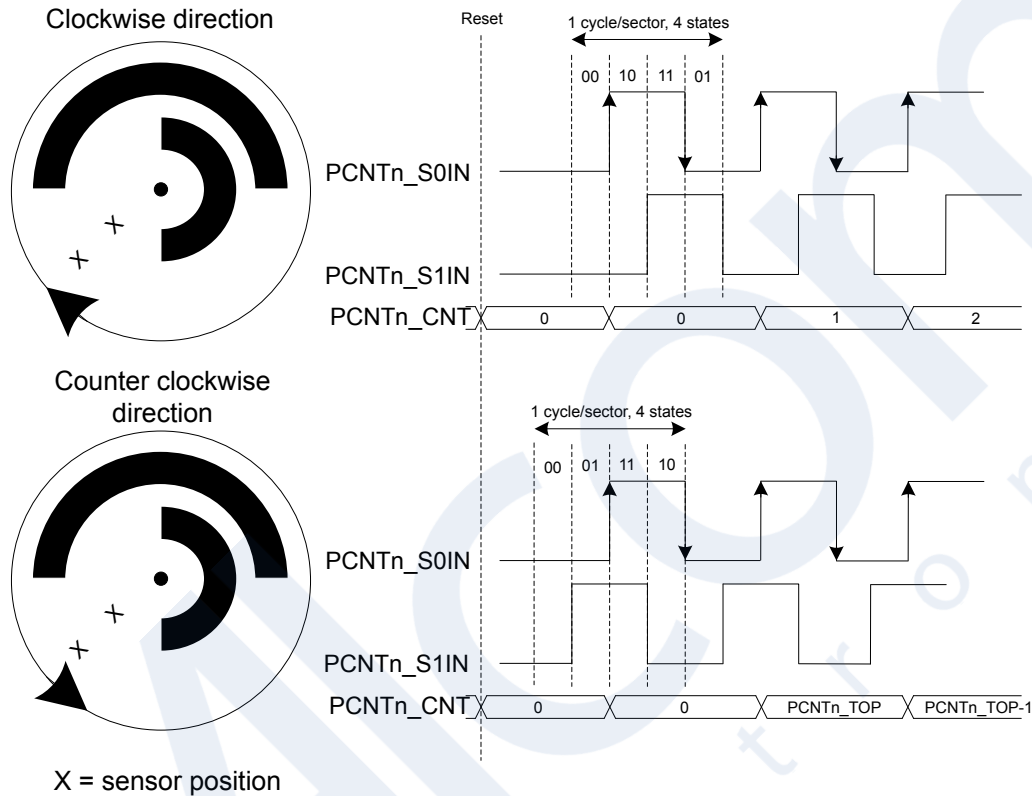

Figure 27.2. PCNT Quadrature Coding

If PCNTn_S0IN leads PCNTn_S1IN in phase, the direction is clockwise, and if it lags in phase the direction is counter-clockwise. Default behavior is illustrated by [Figure 27.2 PCNT Quadrature Coding on page 1052](#).

The counter direction may be read from the DIR bit in the PCNTn_STATUS register. Additionally, the DIRCNG interrupt in the PCNTn_IF register is generated when a direction change is detected. When a change is detected, the DIR bit in the PCNTn_STATUS register must be read to determine the current new direction.

Note: The sector disc illustrated in the figure may be finer grained in some systems. Typically, they may generate 2-4 PCNTn_S0IN wave periods per 360° rotation.

The direction of the quadrature code and control of the counter is generated by the simple binary function outlined by [Table 27.1 PCNT QUAD Mode Counter Control Function on page 1052](#). Note that this function also filters some invalid inputs that may occur when the shaft changes direction or temporarily toggles direction.

Table 27.1. PCNT QUAD Mode Counter Control Function

Inputs		Control/Status	
S1IN posedge	S1IN negedge	Count Enable	CNTDIR status bit
0	0	0	0

Inputs		Control/Status	
S1IN posedge	S1IN negedge	Count Enable	CNTDIR status bit
0	1	1	0
1	0	1	1
1	1	0	0

Note: PCNTn_S1IN is sampled on both edges of PCNTn_S0IN.

27.3.1.5 Oversampling Quadrature Decoder Mode

There are three Oversampling Quadrature Decoder Modes supported: 1X , 2X and 4X. These modes are enabled by writing OVSQUAD1X, OVSQUAD2X and OVSQUAD4X, respectively, to the MODE field in PCNTn_CFG. The STARTCNT bit in PCNTn_CMD is used to start the counter, and STOPCNT can be used to stop the counter. The EM23GRPACLK clock source to the pulse counter must be selected by setting CLKSEL in the CMU_PCNT0CLKCTRL register to EM23GRPACLK.

The optional pulse width filter is enabled by setting the FILTEN bit in the PCNTn_CFG register. The filter applies to both inputs PCNTn_S0IN and PCNTn_S1IN. The filter length is configured by FILTLEN in PCNTn_OVSCTRL register.

Based on the modes selected, the decoder updates the counter on different events. In the OVSQUAD1X mode, the counter is updated on the rising edge of the PCNTn_S0IN input when counting up, and on the negeedge of the PCNTn_S0IN input when counting down. In the OVSQUAD2X mode, the counter is updated on both edges of PCNTn_S0IN input. In the OVSQUAD4X mode the counter is updated on both edges of both inputs PCNTn_S0IN and PCNTn_S1IN. [Table 27.2 PCNT OVSQUAD 1X, 2X and 4X Mode Counter Control Function on page 1054](#) outlines the increment or decrement of the counter based on the Quadrature Mode selected.

Note: The decoding behavior of OVSQUAD1X mode is slightly different compared to EXTCLKQUAD mode(also 1X mode). In the EXTCLKQUAD mode, the counter is updated only on the posedge of S0IN input. However, in the OVSQUAD1X mode, the counter is updated on the posedge of S0IN when counting up and on the negeedge of S0IN when counting down.

Table 27.2. PCNT OVSQUAD 1X, 2X and 4X Mode Counter Control Function

Direction	Previous State		Next State		OVSQUAD MODE		
	S1IN	S0IN	S1IN	S0IN	1X	2X	4X
Clockwise	0	0	0	1	+1	+1	+1
	0	1	1	1			+1
	1	1	1	0		+1	+1
	1	0	0	0			+1
Counter Clockwise	1	0	1	1		-1	-1
	1	1	0	1			-1
	0	1	0	0	-1	-1	-1
	0	0	1	0			-1

[Figure 27.3 PCNT State Transitions for Different Oversampling Quadrature Decoder Modes on page 1055](#) illustrates the different states of the quadrature input and the state transitions that updates the counter for the different modes. Each cycle of the input states results in 1 update, 2 updates and 4 updates of the counter for OVSQUAD1X, OVSQUAD2X and OVSQUAD4X modes respectively.

Relationship between inputs and its state

STATE	S1IN	S0IN
S0	0	0
S1	0	1
S2	1	1
S3	1	0

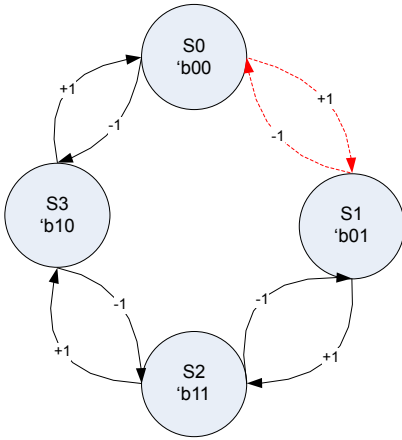

OVSQUAD1X mode
Transitions between States **S0**
and **S1** updates the counter

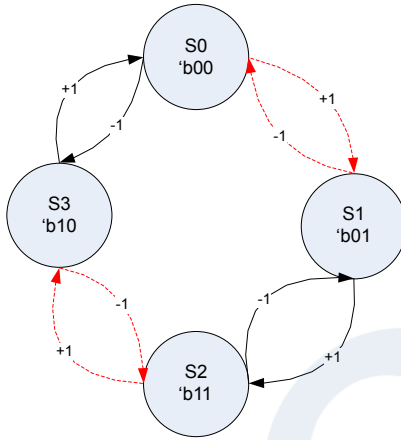

OVSQUAD2X mode
Transitions between States **S0**
and **S1** and between **S3** and **S2**
updates the counter

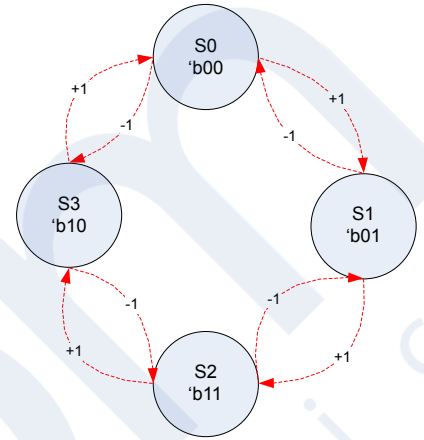

OVSQUAD4X mode
All state transitions updates the counter

Figure 27.3. PCNT State Transitions for Different Oversampling Quadrature Decoder Modes

The counter direction can be read from the DIR bit in PCNTn_STATUS register. Additionally, the DIRCNG interrupt in the PCNTn_IF is generated when the direction change is detected. When a change is detected, the DIR bit in the PCNTn_STATUS register must be read to determine the new direction.

In the oversampling quadrature decoder modes, the maximum input toggle frequency supported is PCNTnCLK / 4. For frequencies above PCNTnCLK / 4, incorrect decoding occurs. The different decoding modes and the counter updates are further illustrated by [Figure 27.4 PCNT Oversampling Quadrature Decoder 1X Mode on page 1055](#), [Figure 27.5 PCNT Oversampling Quadrature Decoder 2X Mode on page 1056](#) and [Figure 27.6 PCNT Oversampling Quadrature Decoder 4X Mode on page 1056](#).

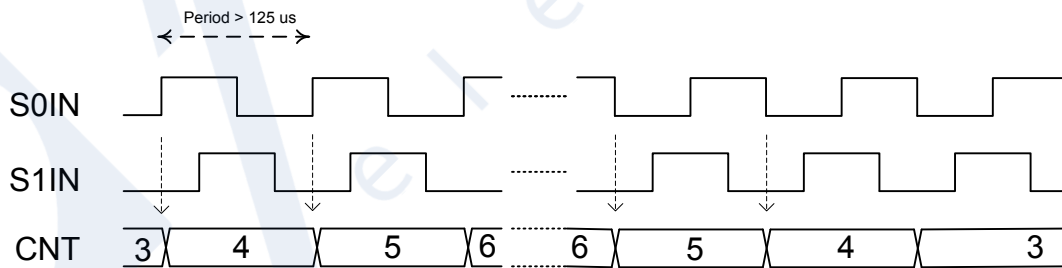

Figure 27.4. PCNT Oversampling Quadrature Decoder 1X Mode

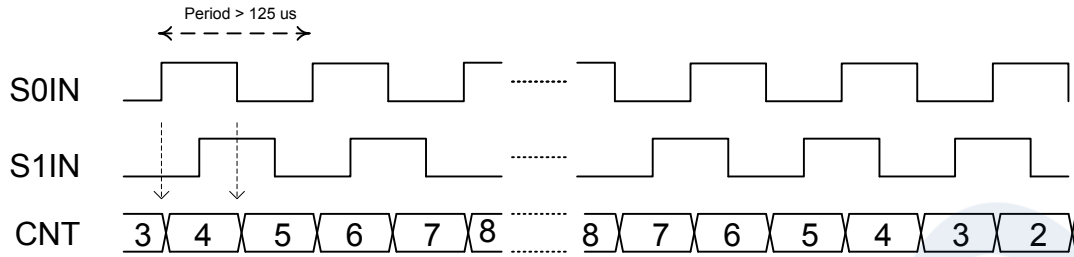

Figure 27.5. PCNT Oversampling Quadrature Decoder 2X Mode

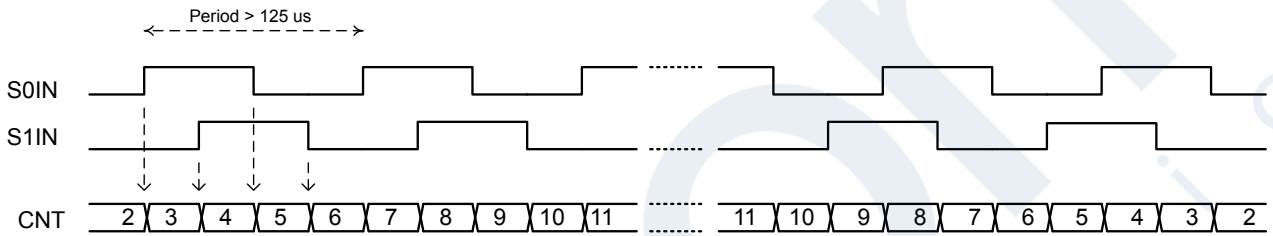

Figure 27.6. PCNT Oversampling Quadrature Decoder 4X Mode

The above modes, by default, are prone to flutter effects in the inputs PCNTn_S0IN and PCNTn_S1IN. When this occurs, the counter changes directions rapidly causing DIRCNG interrupts and unnecessarily waking the core. To prevent this, set FLUTTERM in the PCNTn_OVSCTRL register. When enabled, flutter is removed, thus preventing unnecessary wakeup of the core. The flutter removal logic works by preventing update of the counter value if the wheel keeps changing direction as a result of flutter. The counter is only updated if the current and previous state transition of the rotation are in the same direction. These state transitions are quadrature decoder mode specific. The highlighted state transitions in [Figure 27.3 PCNT State Transitions for Different Oversampling Quadrature Decoder Modes on page 1055](#) are the ones considered for the different quadrature decoder modes. [Figure 27.7 PCNT Oversampling Quadrature Decoder with Flutter Removal on page 1056](#) shows how the counter is updated for the different quadrature decoder modes with flutter removal FLUTTERM enabled in PCNTn_OVSCTRL.

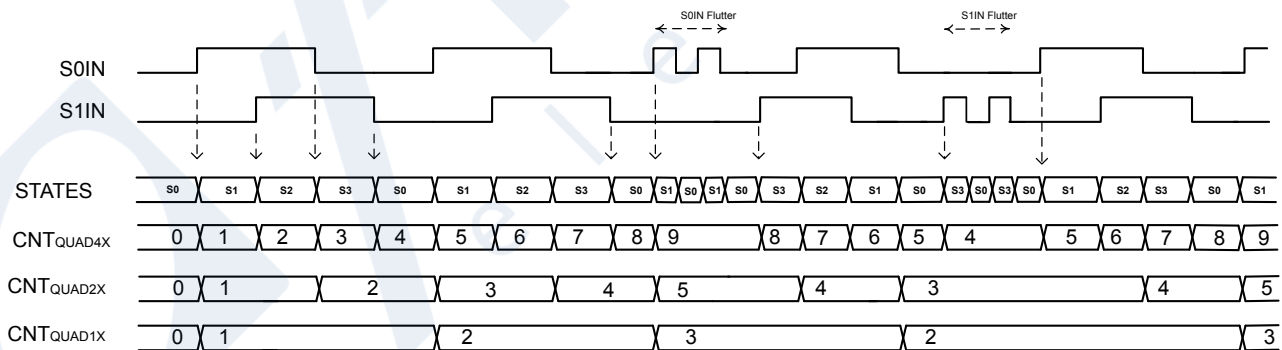

Figure 27.7. PCNT Oversampling Quadrature Decoder with Flutter Removal

27.3.2 Hysteresis

By default the pulse counter wraps to 0 when passing the configured top value, and wraps to the top value when counting down from 0. On these events, a system will likely want to wake up to store and track the overflow count. This is fine if the pulse counter is tracking a monotonic value or a value that does not change directions frequently. In the latter scenario, if the counter changes directions around the overflow/underflow point, the system will have to wake up frequently to keep track of the rotations, resulting in higher current consumption.

To solve this, the pulse counter has a way of introducing hysteresis to the counter. When HYST in PCNTn_CFG is set, the pulse counter will always wrap to TOP/2 on underflows and overflows. This takes the counter away from the area where it might overflow or underflow, removing the problem. [Figure 27.8 PCNT Hysteresis behavior of Counter on page 1057](#) illustrates the hysteresis behavior.

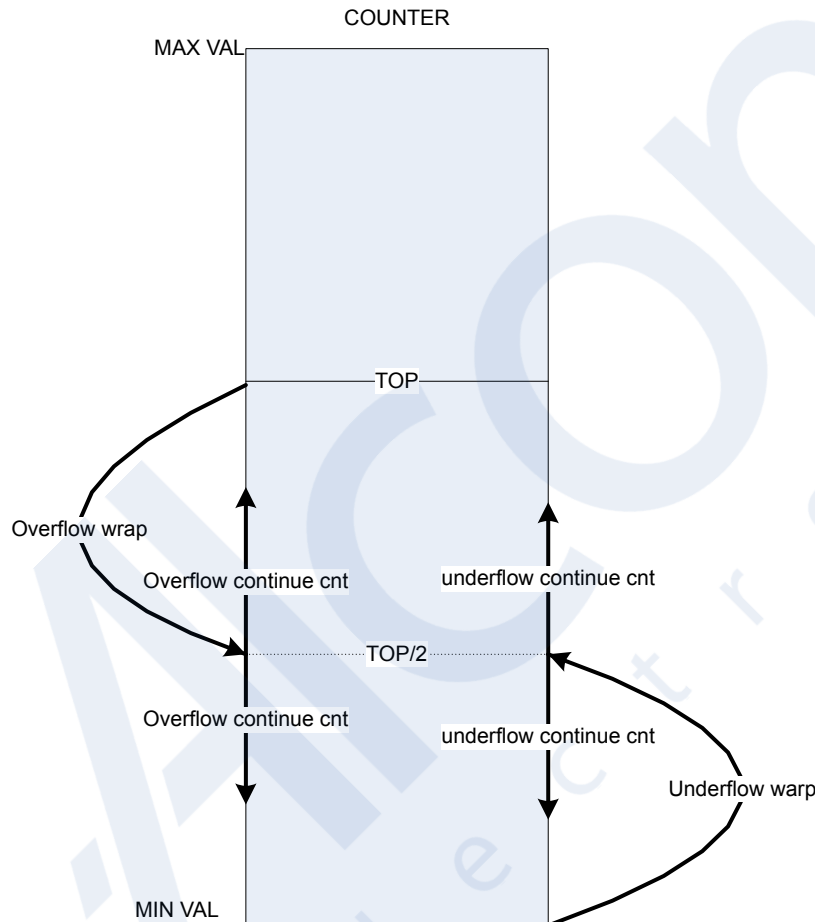

Figure 27.8. PCNT Hysteresis behavior of Counter

Given a starting value of 0 for the counter, the absolute count value when hysteresis is enabled can be calculated with the equations [Figure 27.9 Absolute Position With Hysteresis and Even TOP Value on page 1057](#) or [Figure 27.10 Absolute Position With Hysteresis and Odd TOP Value on page 1057](#), depending on whether the TOP value is even or odd.

$$CNT_{abs} = CNT - UF_{CNT} \times (TOP/2+1) + OF_{CNT} \times (TOP/2+1)$$

Figure 27.9. Absolute Position With Hysteresis and Even TOP Value

$$CNT_{abs} = CNT - UF_{CNT} \times (TOP/2+1) + OF_{CNT} \times (TOP/2+2)$$

Figure 27.10. Absolute Position With Hysteresis and Odd TOP Value

27.3.3 Auxiliary Counter

To be able to keep explicit track of counting in one direction in addition to the regular counter which counts both up and down, the auxiliary counter can be used. The pulse counter can, for instance, be configured to keep track of the absolute rotation of the wheel, while at the same time the auxiliary counter can keep track of how much the wheel has reversed.

The auxiliary counter is enabled by configuring AUXCNTEV in PCNTn_CTRL. It will always count up, but it can be configured whether it should count up on up-events, down-events or both, keeping track of rotation either way or general movement. The value of the auxiliary counter can be read from the PCNTn_AUXCNT register.

Overflows on the auxiliary counter happen when the auxiliary counter passes the top value of the pulse counter, configured in PCNTn_TOP. In that event, the AUXOF interrupt flag is set, and the auxiliary counter wraps to 0.

The auxiliary counter is started and stopped in a similar way to the main counter, using commands in the PCNTn_CMD register. The STARTAUXCNT bit in PCNTn_CMD is used to start the auxiliary counter, and STOPAUXCNT can be used to stop the auxiliary counter.

As the auxiliary counter, the main counter can be configured to count only on certain events. This is done through CNTEV in PCNTn_CTRL, and it is possible like for the auxiliary counter, to make the main counter count on only up and down events. The difference between the counters is that where the auxiliary counter will only count up, the main counter will count up or down depending on the direction of the count event.

27.3.4 Register Access

The counter-clock domain may be clocked externally. To update the counter-clock domain registers from software in this mode, 2-3 clock pulses on the external clock are needed to synchronize accesses to the externally clocked domain. Clock source switching is controlled from the registers in the CMU.

When the CORERST bit in the PCNTn_CMD register is set by software, the PCNT clock domain is synchronously reset and released two PCNT clock edges later. This synchronous reset restores the reset values in PCNTn_TOP, PCNTn_CNT and other core registers in the PCNT clock domain.

CNTRST works in a similar manner as CORERST, but only resets the counter, CNT. Note that the counter is also reset by CORERST.

AUXCNTRST works in a similar manner as CORERST, but only resets the auxiliary counter, PCNTn_AUXCNT. Note that the auxiliary counter is also reset by CORERST.

Note: PCNTn_CNT is a read-only register. When writing to PCNTn_TOP, make sure that the counter value, PCNTn_CNT, can not exceed the value written to PCNTn_TOP within two clock cycles.

Note: To ensure reset during SWRST, if the counter-clock domain is clocked externally, it is advisable to switch the counter-clock to the internal clock before performing the software reset. The clock pulses from an external source cannot be relied upon. By switching to an internal clock the software reset operation completion will be guaranteed.

27.3.5 Clock Sources

The pulse counter may be clocked from two possible clock sources: EM23GRPACLK or an external clock. The clock selection is configured by setting the CLKSEL field in the CMU_PCNTnCLKCTRL register. The default clock source is the EM23GRPACLK.

This PCNT module may also use PCNTn_S0IN as an external clock to clock the counter (EXTCLKSINGLE mode) and to sample PCNTn_S1IN (EXTCLKQUAD mode). Setup, hold and max frequency constraints for PCNTn_S0IN and PCNTn_S1IN for these modes are specified in the device data sheet.

Note: If changing PCNT to an external clock source, either through the PCNTn_S0IN or S0PRS input, the CMU clock switch will need at least 2 external clocks to sync over to that new clock source. Register will not load and counting will not begin until there are few external clocks.

Note: Switching external clock source to the S0PRS input can cause a clock glitch. So S0PRSEN in PCNTn_CFG should be configured before configuring the CLKSEL field in CMU_PCNTnCLKCTRL.

27.3.6 Input Filter

An optional pulse width filter is available in OVSSINGLE and OVSQUAD modes, when EM23GRPACLK is selected as a clock source for the Pulse Counter. The filter is enabled by writing 1 to the FILTEN bit in the PCNTn_CTRL register. When enabled, the high and low periods of PCNTn_S0IN and PCNTn_S1IN must be stable for a programmable number of consecutive clock cycles before the edge is passed to the edge detector. The filter length should be programmed in FILTEN field of the PCNTn_OVSCTRL register.

The filter length is given by [Figure 27.11 PCNT Input Filter Length Equation on page 1059](#):

$$\text{Filter length} = (\text{FILTEN} + 5) \text{ EM23GRPACLK cycles}$$

Figure 27.11. PCNT Input Filter Length Equation

The maximum filter length configured is 260 EM23GRPACLK cycles.

In EXTCLKSINGLE and EXTCLKQUAD mode, there is no digital pulse width filter available.

27.3.7 Edge Polarity

The edge polarity can be set by configuring the EDGE bit in the PCNTn_CTRL register. When this bit is cleared, the pulse counter counts positive edges of PCNTn_S0IN input. When this bit is set, the pulse counter counts negative edges in OVSSINGLE mode. Also, when the EDGE bit is set in the OVSSINGLE and EXTCLKSINGLE modes, the PCNTn_S1IN input is inverted. In OVSQUAD 1X-4X modes the EDGE bit inverts both inputs.

Note: The EDGE bit in PCNTn_CTRL has no effect in EXTCLKQUAD mode.

27.3.8 PRS and PCNTn_S0IN,PCNTn_S1IN Inputs

It is possible to receive input from a PRS signal on both PCNTn_S0IN (or PCNTn_S1IN) by setting S0PRSEN (or S1PRSEN) in PCNTn_CFG. Routing of PRS channels to the inputs is performed using the PRS_CONSUMER_PCNTn_S0IN and PRS_CONSUMER_PCNTn_S1IN registers.

In the Oversampling quadrature decoder modes, the input frequency should be less than 4 times slower than the sampling clock PCNTnCLK to ensure correct functionality.

In the Single Input Oversampling Mode, the input toggle frequency should be 2 times slower than the sampling clock PCNTnCLK to ensure correct functionality.

In the externally clocked modes (where S0IN or S0PRS is used as PCNTnCLK clock source), the input frequency should be less than 1 MHz to ensure correct functionality.

The PCNT module generates two PRS signals, the PCNTn UFOF signal and the PCNTn DIR signal. The PCNTn UFOF signal is generated when the counter overflows or underflows. The PCNTn DIR signal is a level, and indicates the current direction of count of counter CNT.

27.3.9 Interrupts

The interrupt generated by PCNT uses the PCNTn_INT interrupt vector. Software must read the PCNTn_IF register to determine which module interrupt that generated the vector invocation.

27.3.9.1 Underflow and Overflow Interrupts

The underflow interrupt flag (UF) is set when the counter counts down from 0 (i.e. when the value of the counter is 0 and a new pulse is received). The PCNTn_CNT register is loaded with the PCNTn_TOP value after this event.

The overflow interrupt flag (OF) is set when the counter counts up from the PCNTn_TOP (reload) value (i.e. if PCNTn_CNT = PCNTn_TOP and a new pulse is received). The PCNTn_CNT register is loaded with the value 0 after this event.

27.3.9.2 Direction Change Interrupt

The PCNTn_PCNT module sets the DIRCNG interrupt flag (PCNTn_IF register) for EXTCLKQUAD and OVSQUAD1X-4X modes when the direction of the quadrature code changes. The behavior of this interrupt in the EXTCLKQUAD mode is illustrated by [Figure 27.12 PCNT Direction Change Interrupt \(DIRCNG\) Generation](#) on page 1060.

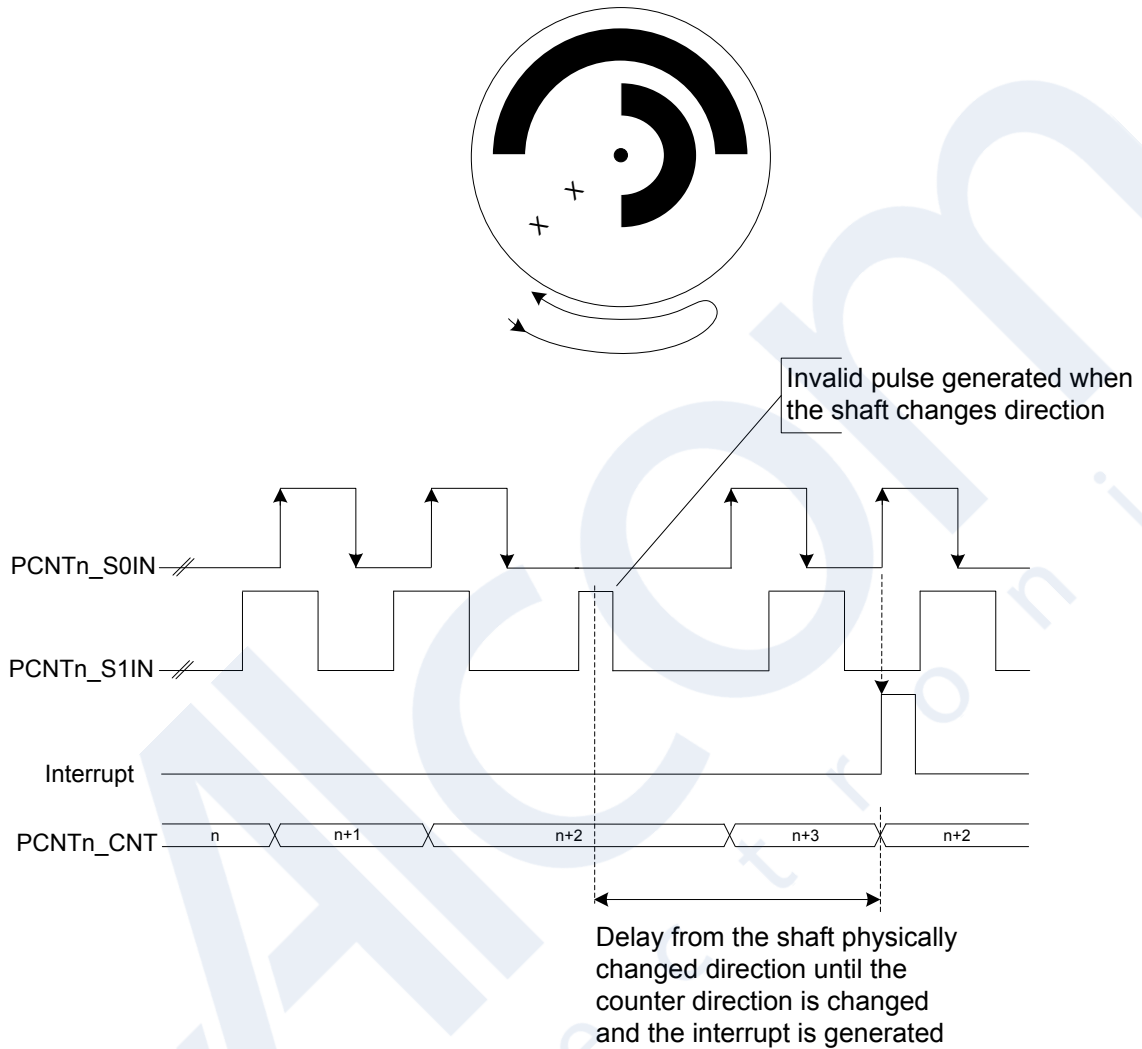

Figure 27.12. PCNT Direction Change Interrupt (DIRCNG) Generation

27.4 PCNT Register Map

The offset register address is relative to the registers base address.

Offset	Name	Type	Description
0x000	PCNT_IPVERSION	R	IP Version ID
0x004	PCNT_EN	RW ENABLE	Module Enable Register
0x008	PCNT_SWRST	RW SWRST	Software Reset Register
0x00C	PCNT_CFG	RW CONFIG	Configuration Register
0x010	PCNT_CTRL	RW LFSYNC	Control Register
0x014	PCNT_CMD	W LFSYNC	Command Register
0x018	PCNT_STATUS	RH	Status Register
0x01C	PCNT_IF	RWH INTFLAG	Interrupt Flag Register
0x020	PCNT_IEN	RW	Interrupt Enable Register
0x024	PCNT_CNT	RH	Counter Value Register
0x028	PCNT_AUXCNT	RH	Auxiliary Counter Value Register
0x02C	PCNT_TOP	RWH LFSYNC	Top Value Register
0x030	PCNT_TOPB	RW LFSYNC	Counter Top Value Buffer Register
0x034	PCNT_OVSCTRL	RW LFSYNC	Oversampling Control Register
0x038	PCNT_SYNCBUSY	RH	Synchronization Busy Register
0x03C	PCNT_LOCK	W	Configuration Lock Register
0x1000	PCNT_IPVERSION_SET	R	IP Version ID
0x1004	PCNT_EN_SET	RW ENABLE	Module Enable Register
0x1008	PCNT_SWRST_SET	RW SWRST	Software Reset Register
0x100C	PCNT_CFG_SET	RW CONFIG	Configuration Register
0x1010	PCNT_CTRL_SET	RW LFSYNC	Control Register
0x1014	PCNT_CMD_SET	W LFSYNC	Command Register
0x1018	PCNT_STATUS_SET	RH	Status Register
0x101C	PCNT_IF_SET	RWH INTFLAG	Interrupt Flag Register
0x1020	PCNT_IEN_SET	RW	Interrupt Enable Register
0x1024	PCNT_CNT_SET	RH	Counter Value Register
0x1028	PCNT_AUXCNT_SET	RH	Auxiliary Counter Value Register
0x102C	PCNT_TOP_SET	RWH LFSYNC	Top Value Register
0x1030	PCNT_TOPB_SET	RW LFSYNC	Counter Top Value Buffer Register
0x1034	PCNT_OVSCTRL_SET	RW LFSYNC	Oversampling Control Register
0x1038	PCNT_SYNCBUSY_SET	RH	Synchronization Busy Register
0x103C	PCNT_LOCK_SET	W	Configuration Lock Register
0x2000	PCNT_IPVERSION_CLR	R	IP Version ID
0x2004	PCNT_EN_CLR	RW ENABLE	Module Enable Register
0x2008	PCNT_SWRST_CLR	RW SWRST	Software Reset Register

Offset	Name	Type	Description
0x200C	PCNT_CFG_CLR	RW CONFIG	Configuration Register
0x2010	PCNT_CTRL_CLR	RW LFSYNC	Control Register
0x2014	PCNT_CMD_CLR	W LFSYNC	Command Register
0x2018	PCNT_STATUS_CLR	RH	Status Register
0x201C	PCNT_IF_CLR	RWH INTFLAG	Interrupt Flag Register
0x2020	PCNT_IEN_CLR	RW	Interrupt Enable Register
0x2024	PCNT_CNT_CLR	RH	Counter Value Register
0x2028	PCNT_AUXCNT_CLR	RH	Auxiliary Counter Value Register
0x202C	PCNT_TOP_CLR	RWH LFSYNC	Top Value Register
0x2030	PCNT_TOPB_CLR	RW LFSYNC	Counter Top Value Buffer Register
0x2034	PCNT_OVSCTRL_CLR	RW LFSYNC	Oversampling Control Register
0x2038	PCNT_SYNCBUSY_CLR	RH	Synchronization Busy Register
0x203C	PCNT_LOCK_CLR	W	Configuration Lock Register
0x3000	PCNT_IPVERSION_TGL	R	IP Version ID
0x3004	PCNT_EN_TGL	RW ENABLE	Module Enable Register
0x3008	PCNT_SWRST_TGL	RW SWRST	Software Reset Register
0x300C	PCNT_CFG_TGL	RW CONFIG	Configuration Register
0x3010	PCNT_CTRL_TGL	RW LFSYNC	Control Register
0x3014	PCNT_CMD_TGL	W LFSYNC	Command Register
0x3018	PCNT_STATUS_TGL	RH	Status Register
0x301C	PCNT_IF_TGL	RWH INTFLAG	Interrupt Flag Register
0x3020	PCNT_IEN_TGL	RW	Interrupt Enable Register
0x3024	PCNT_CNT_TGL	RH	Counter Value Register
0x3028	PCNT_AUXCNT_TGL	RH	Auxiliary Counter Value Register
0x302C	PCNT_TOP_TGL	RWH LFSYNC	Top Value Register
0x3030	PCNT_TOPB_TGL	RW LFSYNC	Counter Top Value Buffer Register
0x3034	PCNT_OVSCTRL_TGL	RW LFSYNC	Oversampling Control Register
0x3038	PCNT_SYNCBUSY_TGL	RH	Synchronization Busy Register
0x303C	PCNT_LOCK_TGL	W	Configuration Lock Register

27.5 PCNT Register Description

27.5.1 PCNT_IPVERSION - IP Version ID

Offset	Bit Position																															
0x000	31	30	29	28	27	26	25	24	23	22	21	20	19	18	17	16	15	14	13	12	11	10	9	8	7	6	5	4	3	2	1	0
Reset	0x1																															
Access	R																															
Name	IPVERSION																															

Bit	Name	Reset	Access	Description
31:0	IPVERSION	0x1	R	IP VERSION Gives access to the IP VERSION of PCNT

27.5.2 PCNT_EN - Module Enable Register

Offset	Bit Position																															
0x004	31	30	29	28	27	26	25	24	23	22	21	20	19	18	17	16	15	14	13	12	11	10	9	8	7	6	5	4	3	2	1	0
Reset																															0x0	0x0
Access																															R	RW
Name																															DISABLING	EN

Bit	Name	Reset	Access	Description
31:2	<i>Reserved</i>	<i>To ensure compatibility with future devices, always write Reserved bits to their reset value, unless otherwise stated. More information in 1.2 Conventions</i>		
1	DISABLING	0x0	R	Disablement busy status When EN is cleared, DISABLING status is set immediately, and cleared when disablement finishes. Disablement resets peripheral cores and not APB registers except the INTFLAG register.
0	EN	0x0	RW	PCNT Module Enable Enable the PCNT module. When EN is cleared(disablement), it halts module operation immediately, and initialize the core domain such that when the is re-enabled, it starts cleanly.

27.5.3 PCNT_SWRST - Software Reset Register

Offset	Bit Position																															
0x008	31	30	29	28	27	26	25	24	23	22	21	20	19	18	17	16	15	14	13	12	11	10	9	8	7	6	5	4	3	2	1	0
Reset																											0x0	0x0				
Access																											R	W				
Name																											RESETTING	SWRST				

Bit	Name	Reset	Access	Description
31:2	Reserved	To ensure compatibility with future devices, always write Reserved bits to their reset value, unless otherwise stated. More information in 1.2 Conventions		
1	RESETTING	0x0	R	Software reset busy status When SWRST command is issued, resetting logic sets RESETTING status immediately, and later it is cleared when reset process finishes.
0	SWRST	0x0	W	Software reset command A software reset command field resets the module back to the initial condition, similar to a power on reset condition

27.5.4 PCNT_CFG - Configuration Register

Offset	Bit Position																																																				
0x00C	31	30	29	28	27	26	25	24	23	22	21	20	19	18	17	16	15	14	13	12	11	10	9	8	7	6	5	4	3	2	1	0																					
Reset																							0x0	0x0		0x0	0x0	0x0																									0x0
Access																							RW	RW		RW	RW	RW																									RW
Name																							S1PRSEN	S0PRSEN																													MODE

Bit	Name	Reset	Access	Description
31:10	Reserved	To ensure compatibility with future devices, always write Reserved bits to their reset value, unless otherwise stated. More information in 1.2 Conventions		
9	S1PRSEN	0x0	RW	S1IN PRS Enable When set, the PRS channel is selected as input to S1IN.
8	S0PRSEN	0x0	RW	S0IN PRS Enable When set, the PRS channel is selected as input to S0IN.
7	Reserved	To ensure compatibility with future devices, always write Reserved bits to their reset value, unless otherwise stated. More information in 1.2 Conventions		
6	HYST	0x0	RW	Enable Hysteresis When hysteresis is enabled, the PCNT will always overflow and underflow to TOP/2.
5	FILTEN	0x0	RW	Enable Digital Pulse Width Filter The filter passes all high and low periods that are at least (FILTLN+5) clock cycles wide. This filter is only available in OVSSINGLE,OVSQUAD1X-4X modes.
4	DEBUGHALT	0x0	RW	Debug Mode Halt Enable Set to halt the PCNT in debug mode only in OVSSINGLE and OVSQUAD modes. When in EXTCLKSINGLE or EXTCLKQUAD modes, DEBUGHALT does not halt the Pulse Counter.
	Value	Mode		Description
	0	DISABLE		PCNT is running in debug mode.
	1	ENABLE		PCNT is frozen in debug mode.
3	Reserved	To ensure compatibility with future devices, always write Reserved bits to their reset value, unless otherwise stated. More information in 1.2 Conventions		
2:0	MODE	0x0	RW	Mode Select Selects the mode of operation. The corresponding clock source must be selected from the CMU.
	Value	Mode		Description
	0	OVSSINGLE		Single input EM23GRPACLK oversampling mode (available in EM0-EM3).
	1	EXTCLKSINGLE		Externally clocked single input counter mode (available in EM0-EM3).
	2	EXTCLKQUAD		Externally clocked quadrature decoder mode (available in EM0-EM3).

Bit	Name	Reset	Access	Description
3	OVSQUAD1X			EM23GRPACLK oversampling quadrature decoder 1X mode (available in EM0-EM3).
4	OVSQUAD2X			EM23GRPACLK oversampling quadrature decoder 2X mode (available in EM0-EM3).
5	OVSQUAD4X			EM23GRPACLK oversampling quadrature decoder 4X mode (available in EM0-EM3).

27.5.5 PCNT_CTRL - Control Register

Offset	Bit Position																															
0x010	31	30	29	28	27	26	25	24	23	22	21	20	19	18	17	16	15	14	13	12	11	10	9	8	7	6	5	4	3	2	1	0
Reset																	0x0	0x0		0x0	0x0	0x0										
Access																	RW	RW		RW	RW	RW										
Name																	AUXCNTEV	CNTEV		EDGE	CNTDIR	S1CDIR										

Bit	Name	Reset	Access	Description												
31:8	Reserved	To ensure compatibility with future devices, always write Reserved bits to their reset value, unless otherwise stated. More information in 1.2 Conventions														
7:6	AUXCNTEV	0x0	RW	<p>Controls When the Aux Counter Counts</p> <p>Selects whether the auxiliary counter responds to up-count events, down-count events or both</p> <table border="1"> <thead> <tr> <th>Value</th> <th>Mode</th> <th>Description</th> </tr> </thead> <tbody> <tr> <td>0</td> <td>BOTH</td> <td>Counts up on both up-count and down-count events.</td> </tr> <tr> <td>1</td> <td>UP</td> <td>Counts up on up-count events.</td> </tr> <tr> <td>2</td> <td>DOWN</td> <td>Counts up on down-count events.</td> </tr> </tbody> </table>	Value	Mode	Description	0	BOTH	Counts up on both up-count and down-count events.	1	UP	Counts up on up-count events.	2	DOWN	Counts up on down-count events.
Value	Mode	Description														
0	BOTH	Counts up on both up-count and down-count events.														
1	UP	Counts up on up-count events.														
2	DOWN	Counts up on down-count events.														
5:4	CNTEV	0x0	RW	<p>Controls When the Counter Counts</p> <p>Selects whether the regular counter responds to up-count events, down-count events or both</p> <table border="1"> <thead> <tr> <th>Value</th> <th>Mode</th> <th>Description</th> </tr> </thead> <tbody> <tr> <td>0</td> <td>BOTH</td> <td>Counts up on up-count and down on down-count events.</td> </tr> <tr> <td>1</td> <td>UP</td> <td>Only counts up on up-count events.</td> </tr> <tr> <td>2</td> <td>DOWN</td> <td>Only counts down on down-count events.</td> </tr> </tbody> </table>	Value	Mode	Description	0	BOTH	Counts up on up-count and down on down-count events.	1	UP	Only counts up on up-count events.	2	DOWN	Only counts down on down-count events.
Value	Mode	Description														
0	BOTH	Counts up on up-count and down on down-count events.														
1	UP	Only counts up on up-count events.														
2	DOWN	Only counts down on down-count events.														
3	Reserved	To ensure compatibility with future devices, always write Reserved bits to their reset value, unless otherwise stated. More information in 1.2 Conventions														
2	EDGE	0x0	RW	<p>Edge Select</p> <p>Determines the polarity of the incoming edges. This bit used only in OVSSINGLE, EXTCLKSINGLE and OVS-QUAD1X-4X modes.</p> <table border="1"> <thead> <tr> <th>Value</th> <th>Mode</th> <th>Description</th> </tr> </thead> <tbody> <tr> <td>0</td> <td>POS</td> <td>Positive edges on the PCNTn_S0IN inputs are counted in OVSSINGLE mode. Does not invert PCNTn_S1IN input in OVSSINGLE and EXTCLKSINGLE modes</td> </tr> <tr> <td>1</td> <td>NEG</td> <td>Negative edges on the PCNTn_S0IN inputs are counted in OVSSINGLE mode. Inverts the PCNTn_S1IN input in OVSSINGLE and EXTCLKSINGLE modes</td> </tr> </tbody> </table>	Value	Mode	Description	0	POS	Positive edges on the PCNTn_S0IN inputs are counted in OVSSINGLE mode. Does not invert PCNTn_S1IN input in OVSSINGLE and EXTCLKSINGLE modes	1	NEG	Negative edges on the PCNTn_S0IN inputs are counted in OVSSINGLE mode. Inverts the PCNTn_S1IN input in OVSSINGLE and EXTCLKSINGLE modes			
Value	Mode	Description														
0	POS	Positive edges on the PCNTn_S0IN inputs are counted in OVSSINGLE mode. Does not invert PCNTn_S1IN input in OVSSINGLE and EXTCLKSINGLE modes														
1	NEG	Negative edges on the PCNTn_S0IN inputs are counted in OVSSINGLE mode. Inverts the PCNTn_S1IN input in OVSSINGLE and EXTCLKSINGLE modes														
1	CNTDIR	0x0	RW	<p>Non-Quadrature Mode Counter Direction Co</p> <p>The direction of the counter must be set in the OVSSINGLE and EXTCLKSINGLE modes. This bit is ignored in EXTCLKQUAD mode as the direction is automatically detected.</p>												

Bit	Name	Reset	Access	Description
	Value	Mode		Description
	0	UP		Up counter mode.
	1	DOWN		Down counter mode.
0	S1CDIR	0x0	RW	Count Direction Determined By S1 Allows S1 give the direction of counting when in the OVSSINGLE or EXTCLKSINGLE modes. When S1 is high, the count direction is given by CNTDIR. When S1 is low, the count direction is the opposite given by CNTDIR

27.5.6 PCNT_CMD - Command Register

Offset	Bit Position																																										
0x014	31	30	29	28	27	26	25	24	23	22	21	20	19	18	17	16	15	14	13	12	11	10	9	8	7	6	5	4	3	2	1	0											
Reset																					0x0	0x0	0x0	0x0													0x0			0x0	0x0	0x0	0x0
Access																					W	W	W	W													W(nB)			W(nB)	W(nB)	W(nB)	W(nB)
Name																					STOPAUXCNT	STOPCNT	STARTAUXCNT	STARTCNT													LCNTIM			AUXCNTRST	CNTRST	CORERST	

Bit	Name	Reset	Access	Description
31:12	<i>Reserved</i>	<i>To ensure compatibility with future devices, always write Reserved bits to their reset value, unless otherwise stated. More information in 1.2 Conventions</i>		
11	STOPAUXCNT	0x0	W	Stop Aux Counter Write a 1 to stop the aux counter
10	STOPCNT	0x0	W	Stop Main Counter Write a 1 to stop the main counter
9	STARTAUXCNT	0x0	W	Start Aux Counter Write a 1 to start the aux counter
8	STARTCNT	0x0	W	Start Main Counter Write a 1 to start the main counter
7:5	<i>Reserved</i>	<i>To ensure compatibility with future devices, always write Reserved bits to their reset value, unless otherwise stated. More information in 1.2 Conventions</i>		
4	LCNTIM	0x0	W(nB)	Load CNT Immediately Load PCNTn_TOP into PCNTn_CNT on the next counter clock cycle.
3	<i>Reserved</i>	<i>To ensure compatibility with future devices, always write Reserved bits to their reset value, unless otherwise stated. More information in 1.2 Conventions</i>		
2	AUXCNTRST	0x0	W(nB)	AUXCNT Reset The auxiliary counter, AUXCNT, is synchronously reset when this bit is set. This action clears the auxiliary counter to its reset value
1	CNTRST	0x0	W(nB)	CNT Reset The counter, CNT, is synchronously reset when this bit is set. This action clears the counter to its reset value
0	CORERST	0x0	W(nB)	PCNT Clock Domain Reset The PCNT clock domain logic is synchronously reset when this bit is set. This action clears the all the PCNT logic and registers to their reset value

27.5.7 PCNT_STATUS - Status Register

Offset	Bit Position																															
0x018	31	30	29	28	27	26	25	24	23	22	21	20	19	18	17	16	15	14	13	12	11	10	9	8	7	6	5	4	3	2	1	0
Reset																											0x0	0x0	0x0	0x0	0x0	
Access																											R	R	R	R	R	
Name																											AUXCNTRUNNING	CNTRUNNING	PCNTLOCKSTATUS	TOPBV	DIR	

Bit	Name	Reset	Access	Description
31:5	<i>Reserved</i>	<i>To ensure compatibility with future devices, always write Reserved bits to their reset value, unless otherwise stated. More information in 1.2 Conventions</i>		
4	AUXCNTRUNNING	0x0	R	Aux Counter running status Indicates the current status of PCNT auxiliary counter running. The counter status will continue to indicate as Running even when it is halted during debug assertion.
3	CNTRUNNING	0x0	R	Main Counter running status Indicates the current status of PCNT main counter running. The counter status will continue to indicate as Running even when it is halted during debug assertion.
2	PCNTLOCKSTATUS	0x0	R	Lock Status Indicates the current status of PCNT Lock
	Value	Mode	Description	
	0	UNLOCKED	PCNT registers are unlocked	
	1	LOCKED	PCNT registers are locked	
1	TOPBV	0x0	R	TOP Buffer Valid This indicates that PCNTn_TOPB contains valid data that has not been written to PCNTn_TOP. This bit is also cleared when PCNTn_TOP is written.
0	DIR	0x0	R	Current Counter Direction Current direction status of the counter. This bit is valid in EXTCLKQUAD mode only.
	Value	Mode	Description	
	0	UP	Up counter mode (clockwise in EXTCLKQUAD mode with the EDGE bit in PCNTn_CTRL set to 0).	
	1	DOWN	Down counter mode.	

27.5.8 PCNT_IF - Interrupt Flag Register

Offset	Bit Position																															
0x01C	31	30	29	28	27	26	25	24	23	22	21	20	19	18	17	16	15	14	13	12	11	10	9	8	7	6	5	4	3	2	1	0
Reset																		0x0	0x0	0x0	0x0	0x0	0x0									
Access																		RW	RW	RW	RW	RW	RW									
Name																		OQSTERR	AUXOF	DIRCNG	OF	UF										

Bit	Name	Reset	Access	Description
31:5	<i>Reserved</i>	<i>To ensure compatibility with future devices, always write Reserved bits to their reset value, unless otherwise stated. More information in 1.2 Conventions</i>		
4	OQSTERR	0x0	RW	Oversampling Quad State Err Int Flag Set in the Oversampling Quadrature Mode when incorrect state transition occurs
3	AUXOF	0x0	RW	Auxiliary Overflow Interrupt Read Flag Set when an Auxiliary CNT overflow occurs
2	DIRCNG	0x0	RW	Direction Change Detect Interrupt Flag Set when the count direction changes. Set in EXTCLKQUAD mode only.
1	OF	0x0	RW	Overflow Interrupt Read Flag Set when a CNT overflow occurs
0	UF	0x0	RW	Underflow Interrupt Read Flag Set when a CNT underflow occurs

27.5.11 PCNT_AUXCNT - Auxiliary Counter Value Register

Offset	Bit Position																															
0x028	31	30	29	28	27	26	25	24	23	22	21	20	19	18	17	16	15	14	13	12	11	10	9	8	7	6	5	4	3	2	1	0
Reset																	0x0															
Access																	R															
Name																	AUXCNT															

Bit	Name	Reset	Access	Description
31:16	Reserved	To ensure compatibility with future devices, always write Reserved bits to their reset value, unless otherwise stated. More information in 1.2 Conventions		
15:0	AUXCNT	0x0	R	Auxiliary Counter Value Gives read access to the auxiliary counter.

27.5.12 PCNT_TOP - Top Value Register

Offset	Bit Position																															
0x02C	31	30	29	28	27	26	25	24	23	22	21	20	19	18	17	16	15	14	13	12	11	10	9	8	7	6	5	4	3	2	1	0
Reset																	0xFF															
Access																	RW															
Name																	TOP															

Bit	Name	Reset	Access	Description
31:16	Reserved	To ensure compatibility with future devices, always write Reserved bits to their reset value, unless otherwise stated. More information in 1.2 Conventions		
15:0	TOP	0xFF	RW	Counter Top Value When counting down, this value is reloaded into PCNTn_CNT when counting past 0. When counting up, 0 is written to the PCNTn_CNT register when counting past this value.

27.5.13 PCNT_TOPB - Counter Top Value Buffer Register

Offset	Bit Position																															
0x030	31	30	29	28	27	26	25	24	23	22	21	20	19	18	17	16	15	14	13	12	11	10	9	8	7	6	5	4	3	2	1	0
Reset																	0xFF															
Access																	RW															
Name																	TOPB															

Bit	Name	Reset	Access	Description
31:16	Reserved	To ensure compatibility with future devices, always write Reserved bits to their reset value, unless otherwise stated. More information in 1.2 Conventions		
15:0	TOPB	0xFF	RW	Counter Top Buffer Register These bits hold the TOP buffer value. Hardware updates the TOP value from TOPB whenever there is Underflow or Overflow event on main counter. The update to TOP wont happen for Overflow event if PCNTn_CTRL.CNTEV = BOTH

27.5.14 PCNT_OVSCTRL - Oversampling Control Register

Offset	Bit Position																															
0x034	31	30	29	28	27	26	25	24	23	22	21	20	19	18	17	16	15	14	13	12	11	10	9	8	7	6	5	4	3	2	1	0
Reset												0x0																				
Access												RW																				
Name												FLUTERRM											FILLEN									

Bit	Name	Reset	Access	Description
31:13	Reserved	To ensure compatibility with future devices, always write Reserved bits to their reset value, unless otherwise stated. More information in 1.2 Conventions		
12	FLUTERRM	0x0	RW	Flutter Remove When set, removes flutter from Quaddecoder inputs S0IN and S1IN. Available only in OVSQUAD1X-4X modes
11:8	Reserved	To ensure compatibility with future devices, always write Reserved bits to their reset value, unless otherwise stated. More information in 1.2 Conventions		
7:0	FILTLEN	0x0	RW	Configure Filter Length for Inputs S0IN Used only in OVSINGLE,OVSQUAD1X-4X modes. To use this first enable FILTEN in PCNTn_CFG register. Filter length = (FILLEN + 5) EM23GRPACLK cycles

27.5.15 PCNT_SYNCBUSY - Synchronization Busy Register

Offset	Bit Position																															
0x038	31	30	29	28	27	26	25	24	23	22	21	20	19	18	17	16	15	14	13	12	11	10	9	8	7	6	5	4	3	2	1	0
Reset																												0x0	0x0	0x0	0x0	0x0
Access																												R	R	R	R	R
Name																												OVCTRL	TOPB	TOP	CMD	CTRL

Bit	Name	Reset	Access	Description
31:5	Reserved	<i>To ensure compatibility with future devices, always write Reserved bits to their reset value, unless otherwise stated. More information in 1.2 Conventions</i>		
4	OVCTRL	0x0	R	OVCTRL Register Busy Set when the value written to OVCTRL register is being synchronized
3	TOPB	0x0	R	TOPB Register Busy Set when the value written to TOPB register is being synchronized
2	TOP	0x0	R	TOP Register Busy Set when the value written to TOP register is being synchronized
1	CMD	0x0	R	CMD Register Busy Set when the value written to CMD register being synchronized
0	CTRL	0x0	R	CTRL Register Busy Set when the value written to CTRL register being synchronized

27.5.16 PCNT_LOCK - Configuration Lock Register

Offset	Bit Position																															
0x03C	31	30	29	28	27	26	25	24	23	22	21	20	19	18	17	16	15	14	13	12	11	10	9	8	7	6	5	4	3	2	1	0
Reset																	0x0															
Access																	W															
Name																	PCNTLOCKKEY															

Bit	Name	Reset	Access	Description						
31:16	<i>Reserved</i>	<i>To ensure compatibility with future devices, always write Reserved bits to their reset value, unless otherwise stated. More information in 1.2 Conventions</i>								
15:0	PCNTLOCKKEY	0x0	W	<p>Configuration Lock Key</p> <p>Write any other value than the unlock code to lock PCNT_CFG, PCNT_EN, PCNT_SWRST, PCNT_CMD, PCNT_CTRL, PCNT_OVSCTRL, PCNT_CNT, PCNT_TOP and PCNT_TOPB registers from editing. Write the unlock code to unlock.</p> <table border="1"> <thead> <tr> <th>Value</th> <th>Mode</th> <th>Description</th> </tr> </thead> <tbody> <tr> <td>42976</td> <td>UNLOCK</td> <td>Write to unlock PCNT lockable registers</td> </tr> </tbody> </table>	Value	Mode	Description	42976	UNLOCK	Write to unlock PCNT lockable registers
Value	Mode	Description								
42976	UNLOCK	Write to unlock PCNT lockable registers								

28. VDAC - Digital to Analog Converter

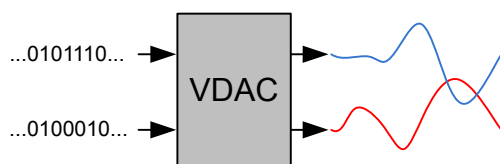
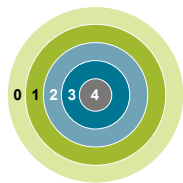

Quick Facts

What?

The VDAC is designed for low energy consumption, but can also provide very good performance. It can convert digital values to analog signals at up to 500 ksamples/second with 12-bit accuracy.

Why?

The VDAC can be used to generate accurate analog signals for sound, sensors and other applications, using only a limited amount of energy.

How?

The VDAC can generate high-resolution analog signals while the MCU is operating at low frequencies and with low total power consumption. Using the LDMA, the VDAC can be used to generate waveforms without any CPU intervention. The VDAC is available down to Energy Mode 3.

28.1 Introduction

The Voltage Digital to Analog Converter (VDAC) converts a digital value to an analog output voltage. It is useful in a number of different applications such as sensor excitation or low/medium frequency sound output. The VDAC has two rail-to-rail output channels that may act as independent DACs or be combined into a differential pair. The output buffers support high or low power operation as well as a high capacitance mode for driving loads up to 50 pF. Both channels have a 4-word FIFO for efficient throughput and minimum CPU intervention. Flexible conversion trigger sources allow for accurate AC and DC waveform timing, and a special sample-off mode can be used in conjunction with periodic output refresh to reduce energy consumption or act as a temporary excitation source.

28.2 Features

Each VDAC instance in a device supports the following features:

- Up to 500 ksps operation
- Two output channels
 - Can be combined into one differential output
- Integrated 7-bit clock prescaler with division factors ranging from 1 to 128
- Selectable voltage reference
 - Internal 2.5 V (effective full-scale)
 - Internal 1.25 V (effective full-scale)
 - AVDD supply
 - External VREFP pin
- Outputs available for internal and external use
 - Main low-impedance outputs to dedicated GPIO
 - Auxiliary outputs routable through ABUS to any ABUS-capable GPIO (higher impedance)
 - Internal routing of auxiliary outputs to other analog blocks
- Data conversion modes selectable per channel
 - Continuous Mode for high speed conversion or constant DC output
 - Sample-off Mode for per-sample conversion followed by channel disable
- Independent FIFO per channel
 - 4 word (12bit) depth for each channel
 - Programmable data valid level
 - Supports software flush
- Conversion trigger sources
 - Data write (software)
 - PRS input (synchronous and asynchronous)
 - Internal timer with power-of-2 selection from 2-64 prescaled clock cycles
- Refresh trigger sources
 - Refresh timer with power-of-2 selection from 2-256 low-frequency clock cycles
 - PRS input (synchronous or asynchronous)
- PRS Communication
 - Separate line for each channel
 - Sync and async PRS output pulse on finished conversion
 - PRS Level Output till channel is warmed
 - Async PRS Output Pulse on Refresh Timer Overflow and Internal Timer Overflow
- LDMA request on FIFO data valid level
 - Independent requests for each DAC channel
- Sine generation mode with differential support

28.3 Functional Description

An overview of the VDAC module is shown [Figure 28.1 VDAC Block Overview Diagram on page 1079](#)

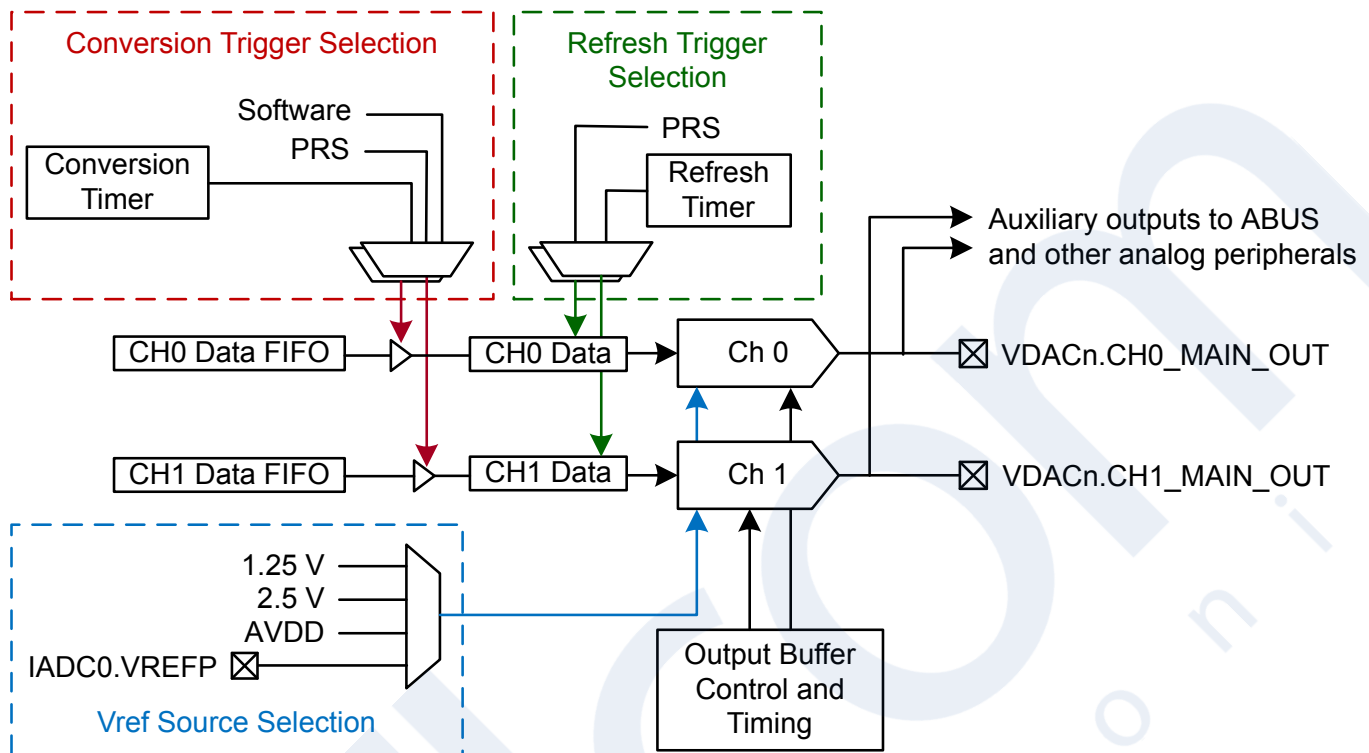

Figure 28.1. VDAC Block Overview Diagram

28.3.1 Power Supply

The VDAC module power (V_{VDAC}) is derived from the AVDD supply pin.

28.3.2 I/O Pin Considerations

The maximum usable analog signal that can be seen on external VDAC outputs depends on both the AVDD and IOVDD supplies. Specifically, the VDAC output will be limited to the lower of the two supply voltages on AVDD and IOVDD.

28.3.3 Enabling and Disabling a Channel

The VDAC module is enabled by writing 1 to EN in VDAC_EN.

A VDAC channel is enabled by writing 1 to the CHxEN and disabled by writing 1 to CHxDIS using in the CMD register. The channel status (enabled or disabled) can be read using the CHxENS bits in the STATUS register. The CHxENS bit will go high after a synchronization delay following a write to CHxEN. When disabling a channel the CHxENS bit will stay high until the VDAC channel is completely disabled.

Software should configure the VDAC before enabling a channel. The following registers are used to configure all the available features of the VDAC:

- VDAC_CFG
- VDAC_CH0CFG
- VDAC_CH1CFG
- VDAC_OUTTIMERCFG

A VDAC channel will not begin driving its output before it is enabled *and* has received a conversion trigger or refresh trigger. After a channel is enabled, it will listen for either conversion trigger sources specified in TRIGMODE in VDAC_CHxCFG or refresh trigger sources specified in REFRESHSOURCE in VDAC_CHxCFG. If TRIGMODE is set to SW and the CHx FIFO is not empty, a conversion will start immediately when the channel is enabled. When disabling a channel, any pending triggers are flushed.

When disabling the VDAC module, user code must poll the status bit VDAC_EN.DISABLING to ensure that the module is cleanly reset and back to its initial condition.

28.3.4 Clock Selection

The VDAC logic accepts three clock sources from the CMU: LSPCLK, VDACn_CLK, and VDACn_REFRESH_CLK. The APB register interface and FIFO write logic are clocked from the LSPCLK. The rest of the VDAC state machine is clocked mainly by a prescaled version of VDACn_CLK. VDACn_DAC from the CMU can be up to 80 MHz. The PRESC bit field in the CFG register should be set to scale VDACn_CLK to no more than 1 MHz. The VDACn_REFRESH_CLK is a low-frequency clock source which only clocks the dedicated refresh timer.

The clock request for VDACn_CLK to the CMU from VDAC is on-demand by default. This means the VDAC core clock is gated off most of the time except:

- New Conversion or Refresh Trigger
- Sine Generation Active Window
- VDAC_CHxCFG.TRIGMODE = SYNCPRS
- VDAC_CHxCFG.REFRESHSOURCE = SYNCPRS
- VDAC_CHxCFG.TRIGMODE = SW and the VDAC CHx FIFO is not empty
- VDAC_CHxCFG.TRIGMODE = INTTIMER

In some cases it is necessary or preferred to have the VDAC clock active all the time. To turn off on-demand clocking, the VDAC_CFG.ONDEMANDCLK bit can be set to '1', which always requests VDACn_CLK from the CMU. On-demand clocking should be disabled if EM23GRPACLK is selected for VDACn_CLK.

If the VDAC will only perform conversions in EM0 and EM1, any clock source for the VDAC may be used.

If the VDAC is to be operated in EM2 or EM3, VDACn_CLK must be configured to use either HFRCOEM23, EM23GRPACLK or FSRCO instead of the EM01GRPACLK clock. FSRCO is the fast start oscillator which starts quickly but is not as accurate as the other oscillators. HFRCOEM23 is generally recommended for EM2/EM3 operation. When using FSRCO or HFRCOEM23, the clock source can be selected to be "on demand" so as not to waste current when the DAC is not doing a conversion. On demand clocking is configured by setting VDAC_CFG.ONDEMANDCLK to 0.

EM23GRPACLK is recommended only when VDAC is expected to do very slow sample conversions/refresh. VDAC_CFG.ONDEMANDCLK should be set to 1 if EM23GRPACLK is selected as the VDAC clock source.

Note: When HFRCOEM23 is selected as a clock source to VDAC and clocking is on-demand (CFG.ONDEMANDCLK = 0), HFRCOEM23 on-demand clocking must be enabled. This allows the power domain which powers HFRCOEM23 to be ON during EM2 and the clock request to HFRCOEM23 can be honored.

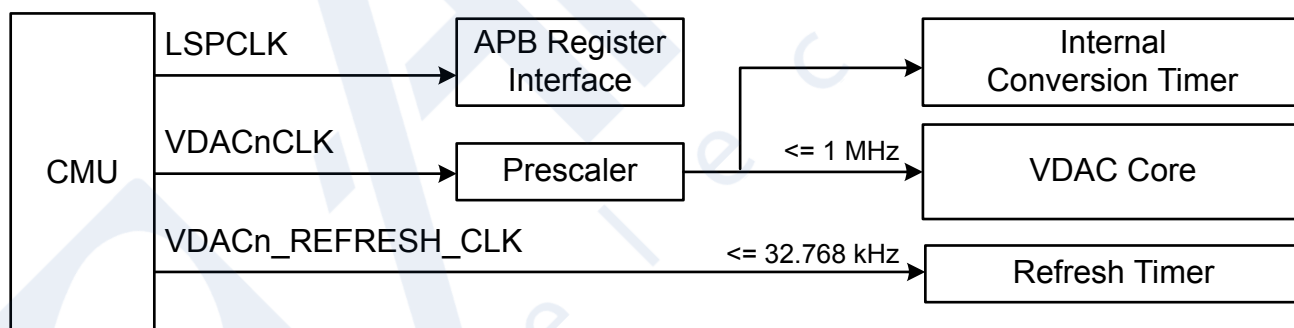

Figure 28.2. VDAC Block Clocks Diagram

28.3.4.1 Internal Clock Prescaler

The VDAC has an internal clock prescaler, which can divide the `VDACn_CLK` input clock by any factor between 1 and 128, by setting the `PRESC` field in the `CFG` register. The resulting prescaled clock is 50% duty cycle and is used by the converter core. The frequency is given by [Figure 28.3 VDAC Clock Prescaling on page 1082](#) :

$$f_{\text{CLK_DAC_PRESC}} = f_{\text{VDACn_CLK}} / (\text{PRESC} + 1)$$

Figure 28.3. VDAC Clock Prescaling

where $f_{\text{VDACn_CLK}}$ is the input clock frequency coming from the CMU. The $f_{\text{CLK_DAC_PRESC}}$ must be programmed to be at most 1 MHz.

The prescaler runs continuously when the VDAC is enabled or when `VDAC_SWRST.SWRST` is set. When running with a prescaler setting higher than 0, there can be an unpredictable delay from the time a conversion was triggered to the time the actual conversion takes place. This is because the conversions are controlled by the prescaled time base, and the conversion can arrive at any time during a prescaled clock (`CLK_DAC_PRESC`) period. A second reason for unpredictable delay between a trigger and the associated conversion is that the activity on one channel can impact whether the VDAC reference is warm or not - when two channels are used independently with warmup, it can impact whether a warmup is required on a trigger.

The uncertainty related to the clock prescaler can be addressed by using `CH0PRESCRST`. If the `CH0PRESCRST` bit in `VDAC_CFG` is set, the prescaler will be reset every time a conversion is triggered on channel 0. This leads to a predictable latency between channel 0 triggers and conversions (assuming the warmup sequence is deterministic as well). If channel *x* is used in continuous mode, the warm-up sequence will only apply once when the channel is enabled and software can use the `VDAC_STATUS.CHxWARM` bit to determine if the VDAC has warmed up.

28.3.4.2 VDACn_REFRESH_CLK

VDAC also has another clock coming in from the CMU, `VDACn_REFRESH_CLK`. This clock is asynchronous to the `VDACn_CLK` and is used to clock the internal refresh timer. `VDACn_REFRESH_CLK` is connected directly to the `EM23GRPACLK` source in the CMU and hence it is a low-frequency clock source with a maximum frequency of ~32 kHz. The refresh timer inside VDAC is a slow running, low power timer. When this refresh timer is used as a refresh trigger source and the timer overflows, it will trigger a `VDACn_CLK` on-demand request from the CMU.

28.3.5 Conversions

The VDAC consists of two channels (channel 0 and 1) with separate 4 deep FIFOs with 12-bits data elements (`VDAC_CHxF.DATA`). These can be used to produce two independent single ended outputs or the channel 0 register can be used to drive both outputs in a differential mode. The VDAC supports two conversion modes: **continuous** and **sample-off**.

Continuous Mode

In continuous mode the VDAC buffers will remain on, and channels will drive their outputs continuously till the channel is disabled with the data in the `VDAC_CHxF.DATA` register. A channel is configured in continuous mode by programming the `CONVMODE` bitfield in `VDAC_CHxCFG` to `CONTINUOUS`. This mode will maintain the output voltage from a conversion indefinitely, until a new output is triggered or until the channel is disabled.

In continuous mode the `CHxOUTHOLDTIME` field in `VDAC_OUTTIMERCFG` should be programmed to zero to achieve the maximum update rate. Both these settings need to be configured before VDAC module is enabled.

Sample-off Mode

In sample-off mode the VDAC will only drive the output for a limited time per conversion. A channel is configured in sample-off mode by programming the `CONVMODE` bitfield in `VDAC_CHxCFG` to `SAMPLEOFF`. The `CHxOUTHOLDTIME` field in the `VDAC_OUTTIMERCFG` register determines how long the output will be driven after a conversion or refresh trigger occurs. The VDAC will drive the output for `CHxOUTHOLDTIME` number of `CLK_DAC_PRESC` cycles before tri-stating the output again (and therefore if `CHxOUTHOLDTIME` is set to zero, the output will never be driven when using sample-off mode). Both these settings need to be configured before VDAC module is enabled.

28.3.6 Conversion Trigger

Conversions can only be performed while a channel is enabled and the CHx FIFO is not empty, see [28.3.3 Enabling and Disabling a Channel](#).

- If CHxCFG.TRIGMODE is programmed to SW, a conversion can be started automatically when the CHx.FIFO is not empty. Writing to the FIFO will trigger a conversion on the specified channel.
- If CHxCFG.TRIGMODE is programmed to SYNCPRS or ASYNCPRS, a conversion can be started by an incoming pulse on the selected PRS channel. VDAC expects a PRS pulse coming from both synchronous and asynchronous PRS producers. Depending on the TRIGMODE and channel enable, the VDAC will process the PRS pulse from the respective producer.
- If CHxCFG.TRIGMODE is programmed to INTERNALTIMER, the internal timer is used to start conversions, and a new conversion will start on any overflow of the internal timer. See [28.3.13 Internal Timers](#).

28.3.7 Refresh Trigger

The refresh mechanism can be used to periodically refresh the output with the most recent conversion result. A refresh trigger can only happen while a channel is enabled, see [28.3.3 Enabling and Disabling a Channel](#).

- If CHxCFG.REFRESHSOURCE is programmed to SYNCPRS or ASYNCPRS, a refresh can be started by an incoming pulse on the selected PRS channel. The VDAC refresh mechanism requires a PRS pulse for either configuration of CHxCFG.REFRESHSOURCE. Depending on the REFRESHSOURCE and channel enable, VDAC processes the PRS pulse from the respective producer.
- If CHxCFG.REFRESHSOURCE is programmed to REFRESHTIMER, a conversion will start on an overflow of the refresh timer. See [28.3.13 Internal Timers](#).

Note: The refresh mechanism never pops a new conversion from the FIFO. It just re-triggers the conversion based on the last data converted by the conversion trigger to generate the same voltage output at the load. A periodic refresh of the output voltage into a suitable RC filter (to reduce ripple) may be a way to establish a low-energy DC bias in some applications.

Conversion Trigger and Refresh Trigger co-existence

- Conversion triggers are given preference over refresh triggers. During a conversion trigger sample conversion, if a refresh trigger occurs it is ignored.
- Refresh triggers are served only when the conversion trigger sample conversion is completely finished.
- During a refresh trigger sample conversion, if a conversion trigger occurs, it is held by the VDAC and served once the refresh trigger conversion is finished. The VDAC never ignores conversion triggers.

28.3.8 PRS Communication

PRS triggers can be used to set a constant sample frequency, for instance by using a TIMER, or to synchronize conversion events with other hardware. In order to get a jitter-free sample rate from a PRS source, set CHxCFG.TRIGMODE to SYNCPRS and set the CFG.CH0PRESCRST bit to ensure the prescaler is reset on trigger. Note that because the prescaler is shared between channels, this is only possible for channel 0.

For CHxCFG.TRIGMODE / CHxCFG.REFRESHSOURCE of ASYNCPRS, the sample frequency cannot be guaranteed to be jitter-free with respect to the PRS pulses. The CH0PRESCRST bit in VDAC_CFG can still be set to reset the clock prescaler on every PRS trigger for better predictability. Note, this can be set only on channel 0.

The Input PRS frequency should never be higher than 0.5 MHz (the fastest possible sample rate). In addition, the input PRS frequency should not be higher than $f_{VDACn_CLK} / 4$ (in synchronous mode). If the PRS frequency is set too high, some PRS pulses may be dropped and the output can jitter.

VDAC also sends out the following list of output signals as a PRS producer:

- CHxDONEASYNC - CHx Conversion Done Asynchronous PRS Pulse Output
- CHxWARM - CHx Output Valid Async PRS Level Output
- CHxDONESYNC - CHx Conversion Done Sync PRS Pulse Output
- REFRESHTIMEROF - Refresh Timer Overflow Async PRS Pulse Output
- INTERNALTIMEROF - Internal Timer Overflow Async PRS Pulse Output

28.3.9 Reference Selection

The VDAC supports four voltage reference options:

- Internal 1.25 V Reference (effective full scale)
- Internal 2.5 V Reference (effective full scale)
- AVDD
- External IADC0.VREFP Pin

The voltage reference is selected by programming the REFRSEL field in VDAC_CFG, and is shared for both VDAC channels. The selected voltage reference sets the full scale output voltage of the VDAC. In the case of the internal 1.25 V and 2.5 V reference options, the VDAC uses a lower internal voltage as the reference, and scaling techniques to produce an effective full scale voltage of 1.25 V or 2.5 V respectively. The 2.5 V internal reference can still be used over the entire supply voltage range of the device without any dropout. However, the output will be limited by the supply rail(s) and VDAC will not be able to drive above the supply.

28.3.10 Power Modes

The VDAC supports independently-selectable high power and low power modes per channel. Each has a maximum load capacitance of 50 pF. The power mode for each channel is configured by setting VDAC_CHxCFG.POWERMODE. By default, the VDAC starts in HIGHPOWER mode.

VDAC also supports an additional high capacitance load mode in conjunction with the HIGHPOWER power mode. High capacitance mode is enabled by setting VDAC_CHxCFG.HIGHCAPLOADEN to 1. The minimum load capacitance on the pin is 25 nF for this mode.

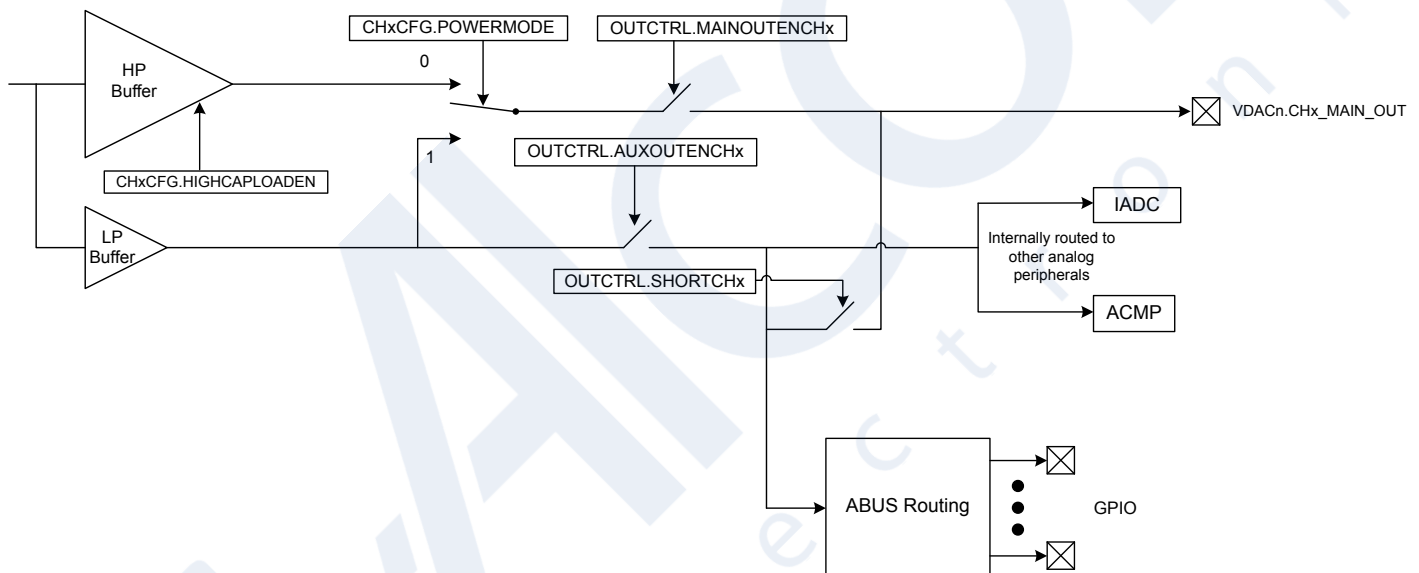

Figure 28.4. VDAC Block Power Modes Diagram

28.3.11 Warmup Time and Initial Conversion

When a channel is enabled, it needs to warm up. This is performed automatically when the channel is enabled if the CONVMODE in VDAC_CHxCFG is set to Continuous mode.

If the CONVMODE in VDAC_CHxCFG is set to Sample-off mode, then every sample conversion is preceded by warmup of the VDAC. Hence, the sample conversion time in case of sample-off mode includes the WARMUPTIME of the VDAC too.

The time allocated for warmup depends on the WARMUPTIME field in VDAC_CFG. WARMUPTIME is specified in prescaled VDACn_CLK cycles and should be set to a minimum of 3 us (3 clocks if CLK_DAC_PRESC = 1 MHz). Software is responsible for programming the correct value to WARMUPTIME before enabling a channel. If the time is programmed too short, an undefined voltage may be output until the analog portion of VDAC settles.

The CHxWARM bits in VDAC_STATUS are set when the warmup period has completed. A consequence of the warmup period is that in continuous mode, the recommended programming model is to either wait for CHxWARM status before starting conversions in order to make sure all samples have the same timing, or perform a dummy conversion to make the VDAC settle to a known voltage first.

28.3.12 Output Mode

The two VDAC channels can act as two separate single-ended channels or be combined into one differential channel. This is selected through the DIFF bit in VDAC_CFG.

■ Single Ended Output

When operating in single ended mode, the channel 0 output is on VDAC_OUT0 and the channel 1 output is on VDAC_OUT1. The output voltage can be calculated using [Figure 28.5 VDAC Single Ended Output Voltage on page 1085](#)

$$V_{OUT} = V_{VDACn_OUTx} - V_{SS} = V_{ref} \times CHxDATA/4096$$

Figure 28.5. VDAC Single Ended Output Voltage

where CHxDATA is a 12-bit unsigned integer.

■ Differential Output

When operating in differential mode, both VDAC outputs are used to produce a differential output. The conversion uses the VDAC_CH0DATA buffer as the data source. The data written to VDAC_CH0DATA is interpreted as a two's complement number, with the MSB of the 12-bit value being the sign bit. Conceptually, a 'positive' and 'negative' output, with a common-mode voltage of $V_{ref}/2$ are generated from this information.

The positive output appears on VDAC_CH1 and the negative output appears on VDAC_CH0. The output voltage can be calculated using [Figure 28.6 VDAC Differential Output Voltage on page 1085](#):

$$V_{OUT} = V_{VDACn_CH1} - V_{VDACn_CH0} = V_{ref} \times CH0DATA/2048$$

Figure 28.6. VDAC Differential Output Voltage

where CH0DATA is a 12-bit signed integer. The common mode voltage is $V_{ref}/2$.

When using differential mode, the user needs to program only CH0 settings to reflect to both channels. Any programmed settings in CH1 will be ignored in differential mode.

28.3.13 Internal Timers

VDAC has two internal timers that run independently of each other:

Conversion Timer

VDAC includes an internal conversion timer. This conversion timer is automatically started if a channel selects INTERNALTIMER as TRIGMODE in VDAC_CHxCFG register and the channel is enabled. The conversion timer will count the number of prescaled VDACn_CLK cycles programmed in VDAC_CFG.TIMEROVERFLOWPERIOD before wrapping and generating a conversion trigger. The timer overflow period is from 2-64 prescaled VDACn_CLK cycles. The conversion timer overflow automatically initiates the sample conversion if the CHxF FIFO is not empty.

INTERNALTIMEROF is also available as an asynchronous PRS signal, generating a pulse that lasts for 1 prescaled VDACn_CLK cycle. Note that since this timer runs off prescaled VDACn_CLK, the VDACn_CLK is always requested from the CMU when the internal conversion timer is used.

Refresh Timer

VDAC includes an internal low power refresh timer. This refresh timer is automatically started if a channel selects REFRESHTIMER as REFRESHSOURCE in VDAC_CHxCFG register and the channel is enabled. The refresh timer will count the number of VDACn_REFRESH_CLK cycles programmed in VDC_CFG.REFRESHPERIOD before wrapping and generating a refresh trigger. The refresh period is from 2-256 VDACn_REFRESH_CLK cycles. The refresh timer overflow automatically initiates the refresh.

REFRESHTIMEROF is also available as an asynchronous PRS signal, generating a pulse that lasts for 1 VDACn_REFRESH_CLK cycle. Note that since this timer runs off VDACn_REFRESH_CLK, which is asynchronous to VDACn_CLK, VDACn_CLK is only requested from the CMU when the refresh timer overflows. Also, as discussed in [28.3.4 Clock Selection](#), this timer always runs off a slow clock, hence this refresh conversion is low power.

28.3.14 FIFO

VDAC has two FIFOs, one for each channel. Each FIFO is 4 samples deep. Data is pushed into the FIFO by either the CPU or LDMA, and happens on the bus clock. Samples are popped from the FIFO on the VDACn_CLK domain by the VDAC core whenever there is a new conversion trigger. Both FIFOs support a data flush from the CPU.

CHxF FIFO Programming Model

Before enabling VDAC, set the low threshold Data Valid Level for each channel by programming VDAC_CHxCFG.FIFODVL Bit. If in DIFF Mode, the channel 1 DVL settings are ignored. Fill the VDAC_CHxF.DATA with the number of entries greater than programmed DVL to avoid triggering of DVL Interrupt. Details of the DVL Interrupt are explained in [28.3.18 Interrupts and Wakeup](#). The number of valid entries per channel can be read from VDAC_STATUS.CHxFIFOCNT (only if VDAC_CFG.ONDEMANDCLK is set to 1). The status of whether the FIFO is full or empty can be read from VDAC_STATUS.CHxFIFOFULL and VDAC_STATUS.CHxFIFOEMPTY respectively.

CHxF FIFO Flush Programming Model

In case there is incorrect data programmed in the FIFO or in the event of a FIFO overflow, the CPU can issue a flush by programming VDAC_CMD.CHxFIFOFLUSH. This flush bit resets both the write pointer (in the bus clock domain) and the read pointer (in the CLK_DAC domain) together. During a flush, new conversions should not be triggered on the channel whose FIFO contents are flushed. The flush status is reported with the VDAC_STATUS.CHxFIFOFLBUSY bit, which will remain high during the flush operation and return low when it is complete. Since the CPU issues flush to the CHx FIFO, there are several steps that should be followed in order to avoid any spurious voltage at VDAC Output:

- Disable the channel using VDAC_CMD.CHxDIS = 1
- Disable the VDAC channel in the LDMA to avoid any new CHxFIFO writes during flushing
- Issue the flush command and poll the VDAC_STATUS.CHxFIFOFLBUSY status bit
- After flushing is complete, re-enable the VDAC channel and optionally re-program the LDMA

28.3.15 Keepwarm Sub-modes

VDAC has two keepwarm modes that can be used with Sample-off Conversion Mode to define the behaviour of the analog portion of the VDAC between sample conversions. The keepwarm mode needs to be set along with Sample-off Conversion Mode before enabling the VDAC module. The two options are:

Bias Keepwarm

Bias Keepwarm Mode is primarily used to reduce kickback to the reference bias, in case it is shared with IADC. This mode can be activated by setting the VDAC_CFG.BIASKEEPWARM Bit to 1. During this mode, the VDAC Analog Bias remains ON in between sample conversions instead of shutting down after the hold time expires.

This mode is only relevant when using the internal 1.25 V or 2.5 V reference selections. This mode does not reduce the required warm-up time of the VDAC. Enabling this mode will typically cost about 4 uA of additional current when the VDAC is idle. The VDAC analog bias remains on irrespective of the channel enable/disable, until the VDAC module is disabled.

Channel Keepwarm

Channel Keepwarm Mode is primarily used to reduce kickback between the two channels, or to reduce the start-up time of the VDAC in-between sample conversions. This mode is activated per channel by setting the VDAC_CHxCFG.KEEPWARM bit to 1. During this mode, the VDAC remains warmed up in-between sample conversions and can convert new samples without incurring a warm up delay. This mode can only be used with Sample-off conversion mode. Setting this mode typically costs about 10-20 uA of additional current when the VDAC is idle.

28.3.16 LDMA Interface

The VDAC has two FIFOs (one per channel) which can be filled using the LDMA whenever there is space available in the FIFO. To facilitate this, the VDAC generates a DMA request per channel to the LDMA when the FIFO count reaches the lower threshold Data Valid Level (DVL). DVL is set by programming VDAC_CHxCFG.FIFODVL to set the watermark.

DMA REQ and SREQ

Both Channel 0 and 1 generate DMA requests in the bus clock domain only when the VDAC_CMD.CHxEN bit is set. In the case of DIFF mode, Channel 1 will not generate LDMA requests. The FIFOs are initially empty, hence as soon as the channels are enabled, each channel will send out a DMA REQ. The request is cleared when FIFO is filled beyond DVL+1.

If there is at least 1 valid space in the FIFO and the DMA channel is not active, each VDAC channel will also send a SREQ to LDMA. This SREQ is also gated with the channel enable.

EM2 Operation

When the system is in EM2, the VDAC can generate new DMA requests as well. This feature can be enabled by setting the VDAC_CFG.DMAWU bit to 1 before enabling VDAC. When enabled and the FIFO count in the read domain falls below the programmed DVL setting, the VDAC will generate a request to the EMU to enter an EM1 state. Once the EMU enters this state and the bus clock is available, VDAC generates the DMA REQ/SREQ per channel to request new data for conversion.

The VDAC keeps the request for data high until the FIFO count is above the programmed DVL setting. Once the condition is met, VDAC automatically pulls the request low and the system can return fully to EM2.

28.3.17 Sine Generation Mode

The VDAC contains an automatic sine-generation mode, which is enabled by setting the SINEMODE bit in VDAC_CFG. In this mode, the VDAC data from the FIFO is overridden with data from an internal hard-coded sine lookup table.

Sine mode is supported only for the fastest configuration of the VDAC in continuous mode. Therefore the CONVMODE bit in VDAC_CH0CFG needs to be set to CONTINUOUS and the CH0OUTHOLDTIME bit in VDAC_OUTTIMERCFG needs to be programmed to zero for channel 0 to use sine generation mode. The TRIGMODE and REFRESHSOURCE bitfields in VDAC_CHxCFG need to be programmed to NONE for channel 0 in order to avoid interference in sine output generation from other triggers. Other trigger modes are not supported. The SINE wave will always be output on channel 0 and therefore requires that this channel is enabled by writing 1 to CH0EN in the VDAC_CMD register. If DIFF is set in VDAC_CFG, the sine wave will additionally be output on channel 1, but inverted. Note that the first sample will only be available after the CHxWARMED bit is 1 in VDAC_STATUS register after setting CH0EN =1 in VDAC_CMD.

Each period, starting at 0 degrees, is made up of 16 samples and the frequency is given by [Figure 28.7 VDAC Sine Generation Frequency on page 1087](#).

$$f_{\text{sine}} = f_{\text{CLK_DAC_PRESC}} / 32$$

Figure 28.7. VDAC Sine Generation Frequency

When DIFF is 0 and SINEMODE is 1 in VDAC_CFG, a sine wave will be generated on channel 0 but channel 1 can still be used independently as a single-ended DAC output. Channel 1 settings are ignored if DIFF is 1.

To configure the VDAC for sine wave output:

- Set VDAC_CFG.SINEMODE to 1 to put the VDAC in sine wave mode
- Set VDAC_CH0CFG.CONVMODE to CONTINUOUS
- Set VDAC_CH0CFG.TRIGMODE to NONE
- Set VDAC_CH0CFG.REFRESHSOURCE to NONE
- Set VDAC_OUTTIMERCFG.CH0OUTHOLDTIME to 0
- Configure VDAC_CFG.DIFF for single-ended or differential output
 - 0 = Single ended output (only channel 0 is used)
 - 1 = Enable differential output (both channel 0 and channel 1 will be used)
- Configure VDAC_CFG.SINERESET for desired behavior when halted
 - 0 = Sine wave output is not reset when halted, and will continue at the next sample when re-started
 - 1 = Sine wave output is reset to 0 degrees when halted, and output will return to Vref / 2
- Set VDAC_CFG.CH0EN to 1 to enable the VDAC module

28.3.17.1 Sine Generation - Software Control

The sine signal generation may be controlled by software using the SINEMODESTART and SINEMODESTOP commands in VDAC_CMD. When SINEMODESTART is set to 1, sine wave generation will be started. Setting SINEMODESTOP to 1 will halt the sine wave generation. If SINERESET in VDAC_CFG is set to 1, the sine output will be reset to 0 degrees when the SINEMODESTOP bit is set to 1, resulting in a voltage of $V_{ref} / 2$ on the output channel(s). If SINERESET equals 0, a SINEMODESTOP command will stop progress of the sine wave at the sample currently being output. The sine will continue at the next sample when SINEMODESTART is issued again.

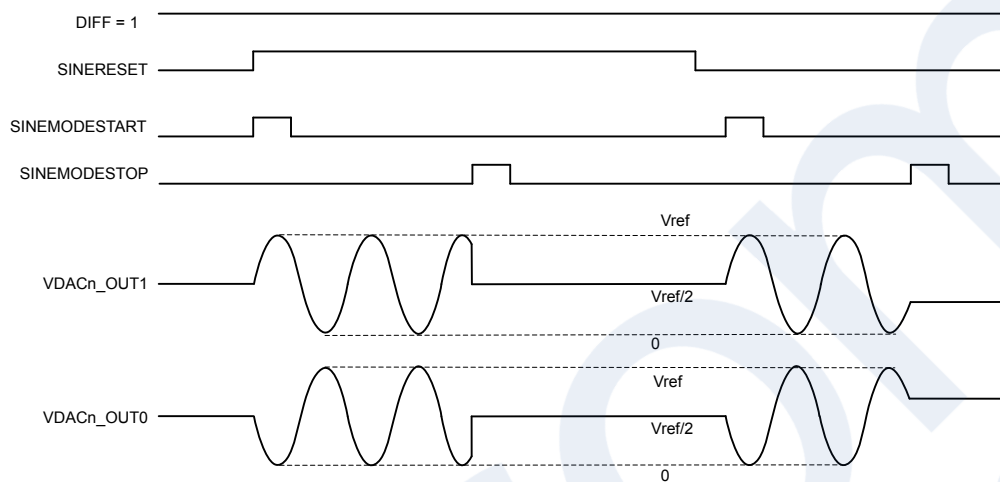

Figure 28.8. VDAC Sine Mode - Software Control

28.3.18 Interrupts and Wakeup

The VDAC has several interrupt flags in the VDAC_IF register, indicating various state and error conditions related to output, FIFO status, and conversions. Each channel has a separate set of interrupt flags.

- **Conversion Done**

The Conversion Done (CHxCD) interrupt flags are set when a conversion is complete. The flags are set after a channel has driven the output with the programmed code.

- **Data Valid Level (DVL)**

The Data Valid Level (CHxDVL) interrupt flags are set when the FIFO Count reaches below or equal to Data Valid Level (DVL). The DVL number is programmed in CHxCFG.DVL Register Bits. These flags are initially set, and gets cleared when CHxF FIFO is filled with new set of data, thereby making count \geq DVL. The FIFO Count can be read through VDAC_STATUS.CHxFIFOCNT Flag. Note that this fifo count is generated in the read domain, hence expect read synchronization delay for the count value.

- **Overflow/Underflow**

If a write is attempted in CHxF FIFO whilst it is full, the channel overflow flag (CHxOF) will be set. If a new conversion is triggered (e.g. via PRS) before whilst CHxF FIFO is empty, the channel underflow flag (CHxUF) will be set. The FIFO full and empty status can be read through VDAC_STATUS.CHxFIFOFULL and VDAC_STATUS.CHxFIFOEMPTY Flags.

- **ABUS Conflict/Allocation Error**

In case both channel 0 and channel 1 request the same Port and Pin for conversion output through ABUS, an ABUS Conflict Error IF (ABUSINPUTCONFLICT) will be set. In case the ABUS Allocation is not coherent with Programmed Port and Pin Setting for either channel, ABUS Allocation Error interrupt flag (ABUSALLOCERR) will be set.

Not all interrupt flags will wake up EMU to EM0 when the VDAC is operating in EM2. Only those interrupts that need interaction with the host will wakeup the CPU. For this, DVL, ABUSALLOCERR and/or ABUSINPUTCONFLICT are used as wakeup interrupt source too.

28.3.19 VDAC Output Configuration

The VDAC analog outputs can be routed either to specific fixed pins, to configurable GPIO through ABUS, or used internally by other blocks. These settings can be programmed in the VDAC_OUTCTRL register after VDAC is enabled but ideally before channels are enabled. The possible settings are as follows:

- VDAC_OUTCTRL.MAINOUTENCHx - Set this bit to route VDAC channel analog main output to the dedicated pin (CHx_MAIN_OUT). This is the preferred option for any DAC output.
- VDAC_OUTCTRL.AUXOUTENCHx - Set this bit to route VDAC channel analog auxiliary output to internal blocks such as IADC and ACMP, or to the ABUS interconnect matrix, where it can be routed to any port I/O supporting ABUS. Note that the ABUS multiplexer adds significant impedance, and this option may not be suitable for certain loads or dynamic conditions.
- VDAC_OUTCTRL.SHORTCHx - Set this bit when using the high-power buffer option with the auxiliary outputs. This will short the MAIN and AUX outputs together. The MAIN output is still driven in this configuration.
- VDAC_OUTCTRL.ABUSPORTSELCHx - Select a particular ABUS port for the channel. Choose values from PORTA, PORTB, PORTC, PORTD
- VDAC_OUTCTRL.ABUSPINSELCHx - Select a particular ABUS pin for the channel. Program the pin in conjunction with the port to route the analog output to a particular GPIO.

Note: Once the channel is enabled, the output control settings in VDAC and the ABUS configuration in both VDAC and GPIO should not be changed until the channel is disabled. Changing these settings while enabled may cause spurious voltage generation on random GPIO.

ABUS Allocation Rules to VDAC in GPIO

- AEVEN0/BEVEN0/CDEVEN0 can only be allocated to CH0
- AEVEN1/BEVEN1/CDEVEN1 can only be allocated to CH1
- AODD0/BODD0/CDODD0 can only be allocated to CH0
- AODD1/BODD1/CDODD1 can only be allocated to CH1
- The port and pin requested by ABUSPORTSELCHx/ABUSPINSELCHx must match a bus allocated to VDAC CHx.

For example, if AEVEN0 is the only bus allocated to CH0, the selected port must be port A, and the selected pin must be even.

More details on ABUS allocation can be found in GPIO chapter

28.4 VDAC Register Map

The offset register address is relative to the registers base address.

Offset	Name	Type	Description
0x000	VDAC_IPVERSION	R	IPVERSION
0x004	VDAC_EN	RW ENABLE	Module Enable
0x008	VDAC_SWRST	RW SWRST	Software Reset Register
0x00C	VDAC_CFG	RW CONFIG	Config Register
0x010	VDAC_STATUS	RH	Status Register
0x014	VDAC_CH0CFG	RW CONFIG	Channel 0 Config Register
0x018	VDAC_CH1CFG	RW CONFIG	Channel 1 Config Register
0x01C	VDAC_CMD	W SYNC	Command Register
0x020	VDAC_IF	RWH INTFLAG	Interrupt Flag Register
0x024	VDAC_IEN	RW	Interrupt Enable Register
0x028	VDAC_CH0F	W	Channel 0 Data Write Fifo
0x02C	VDAC_CH1F	W	Channel 1 Data Write Fifo
0x030	VDAC_OUTCTRL	RW SYNC	DAC Output Control
0x034	VDAC_OUTTIMERCFG	RW CONFIG	DAC Out Timer Config Register
0x1000	VDAC_IPVERSION_SET	R	IPVERSION
0x1004	VDAC_EN_SET	RW ENABLE	Module Enable
0x1008	VDAC_SWRST_SET	RW SWRST	Software Reset Register
0x100C	VDAC_CFG_SET	RW CONFIG	Config Register
0x1010	VDAC_STATUS_SET	RH	Status Register
0x1014	VDAC_CH0CFG_SET	RW CONFIG	Channel 0 Config Register
0x1018	VDAC_CH1CFG_SET	RW CONFIG	Channel 1 Config Register
0x101C	VDAC_CMD_SET	W SYNC	Command Register
0x1020	VDAC_IF_SET	RWH INTFLAG	Interrupt Flag Register
0x1024	VDAC_IEN_SET	RW	Interrupt Enable Register
0x1028	VDAC_CH0F_SET	W	Channel 0 Data Write Fifo
0x102C	VDAC_CH1F_SET	W	Channel 1 Data Write Fifo
0x1030	VDAC_OUTCTRL_SET	RW SYNC	DAC Output Control
0x1034	VDAC_OUTTIMERCFG_SET	RW CONFIG	DAC Out Timer Config Register
0x2000	VDAC_IPVERSION_CLR	R	IPVERSION
0x2004	VDAC_EN_CLR	RW ENABLE	Module Enable
0x2008	VDAC_SWRST_CLR	RW SWRST	Software Reset Register
0x200C	VDAC_CFG_CLR	RW CONFIG	Config Register
0x2010	VDAC_STATUS_CLR	RH	Status Register
0x2014	VDAC_CH0CFG_CLR	RW CONFIG	Channel 0 Config Register
0x2018	VDAC_CH1CFG_CLR	RW CONFIG	Channel 1 Config Register

Offset	Name	Type	Description
0x201C	VDAC_CMD_CLR	W SYNC	Command Register
0x2020	VDAC_IF_CLR	RWH INTFLAG	Interrupt Flag Register
0x2024	VDAC_IEN_CLR	RW	Interrupt Enable Register
0x2028	VDAC_CH0F_CLR	W	Channel 0 Data Write Fifo
0x202C	VDAC_CH1F_CLR	W	Channel 1 Data Write Fifo
0x2030	VDAC_OUTCTRL_CLR	RW SYNC	DAC Output Control
0x2034	VDAC_OUTTIMERCFG_CLR	RW CONFIG	DAC Out Timer Config Register
0x3000	VDAC_IPVERSION_TGL	R	IPVERSION
0x3004	VDAC_EN_TGL	RW ENABLE	Module Enable
0x3008	VDAC_SWRST_TGL	RW SWRST	Software Reset Register
0x300C	VDAC_CFG_TGL	RW CONFIG	Config Register
0x3010	VDAC_STATUS_TGL	RH	Status Register
0x3014	VDAC_CH0CFG_TGL	RW CONFIG	Channel 0 Config Register
0x3018	VDAC_CH1CFG_TGL	RW CONFIG	Channel 1 Config Register
0x301C	VDAC_CMD_TGL	W SYNC	Command Register
0x3020	VDAC_IF_TGL	RWH INTFLAG	Interrupt Flag Register
0x3024	VDAC_IEN_TGL	RW	Interrupt Enable Register
0x3028	VDAC_CH0F_TGL	W	Channel 0 Data Write Fifo
0x302C	VDAC_CH1F_TGL	W	Channel 1 Data Write Fifo
0x3030	VDAC_OUTCTRL_TGL	RW SYNC	DAC Output Control
0x3034	VDAC_OUTTIMERCFG_TGL	RW CONFIG	DAC Out Timer Config Register

28.5 VDAC Register Description

28.5.1 VDAC_IPVERSION - IPVERSION

Offset	Bit Position																															
0x000	31	30	29	28	27	26	25	24	23	22	21	20	19	18	17	16	15	14	13	12	11	10	9	8	7	6	5	4	3	2	1	0
Reset																0x2																
Access																R																
Name																IPVERSION																

Bit	Name	Reset	Access	Description
31:0	IPVERSION	0x2	R	IPVERSION

The read only IPVERSION field gives the version for this module. There may be minor software changes required for modules with different values of IPVERSION.

28.5.2 VDAC_EN - Module Enable

Offset	Bit Position																															
0x004	31	30	29	28	27	26	25	24	23	22	21	20	19	18	17	16	15	14	13	12	11	10	9	8	7	6	5	4	3	2	1	0
Reset																															0x0	0x0
Access																															R	RW
Name																															DISABLING	EN

Bit	Name	Reset	Access	Description
31:2	Reserved	To ensure compatibility with future devices, always write Reserved bits to their reset value, unless otherwise stated. More information in 1.2 Conventions		
1	DISABLING	0x0	R	Disablement busy status When EN is cleared, DISABLING is set immediately, and cleared when disablement finishes. Disablement resets peripheral cores and not APB registers except hardware updated registers such as INTFLAGs and FIFOs.
0	EN	0x0	RW	VDAC Module Enable Enable the VDAC module. When EN is cleared(disablement), it halts module operation immediately, and initialize the core domain such that when the is re-enabled, it starts cleanly.
	Value	Mode	Description	
	0	DISABLE	Disable	
	1	ENABLE	Enable	

28.5.3 VDAC_SWRST - Software Reset Register

Offset	Bit Position																															
0x008	31	30	29	28	27	26	25	24	23	22	21	20	19	18	17	16	15	14	13	12	11	10	9	8	7	6	5	4	3	2	1	0
Reset																															0x0	0x0
Access																															R	W
Name																															RESETTING	SWRST

Bit	Name	Reset	Access	Description
31:2	Reserved	To ensure compatibility with future devices, always write Reserved bits to their reset value, unless otherwise stated. More information in 1.2 Conventions		
1	RESETTING	0x0	R	Software reset busy status When SWRST command is issued, resetting logic sets RESETTING status immediately, and later it is cleared when reset process finishes.
0	SWRST	0x0	W	Software reset command A software reset command field resets the module back to the initial condition, similar to a power on reset condition

28.5.4 VDAC_CFG - Config Register

Offset	Bit Position																																
0x00C	31	30	29	28	27	26	25	24	23	22	21	20	19	18	17	16	15	14	13	12	11	10	9	8	7	6	5	4	3	2	1	0	
Reset			0x2		0x0	0x0	0x0	0x0			0x0				0x0							0x0						0x0	0x0	0x0	0x0	0x0	0x0
Access			RW		RW	RW	RW	RW			RW				RW								RW						RW	RW	RW	RW	RW
Name			WARMUPTIME		DBGHALT	ONDEMANDCLK	DMAWU	BIASKEEPWARM			REFRESHPERIOD				TIMEROVRFLOWPERIOD								PRESC					REFRSEL	CHOPRESCRST	SINERESET	SINEMODE	DIFF	

Bit	Name	Reset	Access	Description
31	Reserved			To ensure compatibility with future devices, always write Reserved bits to their reset value, unless otherwise stated. More information in 1.2 Conventions
30:28	WARMUPTIME	0x2	RW	DAC Warmup Time Number of prescaled CLK_DAC +1 cycles for the VDAC to Warmup. Default is (2+1) prescaled CLK_DAC cycles.
27	DBGHALT	0x0	RW	Debug Halt VDAC behavior when halted by debugger
	Value	Mode		Description
	0	NORMAL		Continue operation as normal during debug mode
	1	HALT		Complete the current conversion and then halt during debug mode
26	ONDEMANDCLK	0x0	RW	Always allow clk_dac Setting this bit to 1 always allows CLK_DAC from CMU
25	DMAWU	0x0	RW	VDAC DMA Wakeup Set to enable wakeup from EM2 to EM1 for DMA to fill CHx FIFO Data
24	BIASKEEPWARM	0x0	RW	Bias Keepwarm Mode Enable Set this bit to keep the Bias on for Analog portion of DAC in between conversions. Primary purpose, is to reduce kick-back to the reference shared with IADC. Relevant only for Sample-off Mode
23	Reserved			To ensure compatibility with future devices, always write Reserved bits to their reset value, unless otherwise stated. More information in 1.2 Conventions
22:20	REFRESHPERIOD	0x0	RW	Refresh Timer Overflow Period Select refresh counter period. A channel x will be refreshed with the period set in REFRESHPERIOD if the channel in VDACn_CHxCFG has its REFRESHSOURCE set to REFRESHTIMER
	Value	Mode		Description
	0	CYCLES2		All channels with enabled refresh are refreshed every 2 CLK_REFRESH cycles

Bit	Name	Reset	Access	Description
1		CYCLES4		All channels with enabled refresh are refreshed every 4 CLK_REFRESH cycles
2		CYCLES8		All channels with enabled refresh are refreshed every 8 CLK_REFRESH cycles
3		CYCLES16		All channels with enabled refresh are refreshed every 16 CLK_REFRESH cycles
4		CYCLES32		All channels with enabled refresh are refreshed every 32 CLK_REFRESH cycles
5		CYCLES64		All channels with enabled refresh are refreshed every 64 CLK_REFRESH cycles
6		CYCLES128		All channels with enabled refresh are refreshed every 128 CLK_REFRESH cycles
7		CYCLES256		All channels with enabled refresh are refreshed every 256 CLK_REFRESH cycles
19	<i>Reserved</i>	<i>To ensure compatibility with future devices, always write Reserved bits to their reset value, unless otherwise stated. More information in 1.2 Conventions</i>		
18:16	TIMEROVRFLOWPERIOD	0x0	RW	Internal Timer Overflow Period Select internal timer overflow period. A channel x will be provided with a conversion trigger after the period set in TIMEOVRFLOWPERIOD if the channel in VDACn_CHxCFG has its TRIGMODE set to INTERNALTIMER
	Value	Mode		Description
	0	CYCLES2		The Timer overflows every 2 Prescaled CLK_DAC cycles
	1	CYCLES4		The Timer overflows every 4 Prescaled CLK_DAC cycles
	2	CYCLES8		The Timer overflows every 8 Prescaled CLK_DAC cycles
	3	CYCLES16		The Timer overflows every 16 Prescaled CLK_DAC cycles
	4	CYCLES32		The Timer overflows every 32 Prescaled CLK_DAC cycles
	5	CYCLES64		The Timer overflows every 64 Prescaled CLK_DAC cycles
15:14	<i>Reserved</i>	<i>To ensure compatibility with future devices, always write Reserved bits to their reset value, unless otherwise stated. More information in 1.2 Conventions</i>		
13:7	PRESC	0x0	RW	Prescaler Setting for DAC clock Selected DAC clock source is prescaled by PRESC+1 to generate prescaled CLK_DAC with 50% duty cycle
6	<i>Reserved</i>	<i>To ensure compatibility with future devices, always write Reserved bits to their reset value, unless otherwise stated. More information in 1.2 Conventions</i>		
5:4	REFRSEL	0x0	RW	Reference Selection Select reference for analog portion of DAC
	Value	Mode		Description
	0	V125		Internal 1.25 V bandgap reference
	1	V25		Internal 2.5 V bandgap reference
	2	VDD		AVDD reference
	3	EXT		External pin reference

Bit	Name	Reset	Access	Description
3	CH0PRESCRST	0x0	RW	Channel 0 Start Reset Prescaler Select if prescaler (determining prescaled CLK_DAC rate) is reset on channel 0 start.
	Value	Mode		Description
	0	NORESETPRESC		Prescaler not reset on channel 0 start
	1	RESETPRESC		Prescaler reset on channel 0 start
2	SINERESSET	0x0	RW	Sine Wave Reset When inactive In case SINERESSET is 0, SINEMODESTOP will stop progress of the sine wave at the sample currently being output in sinemode. When Set to 1, the sine output will reset to 0 degrees when SINEMODESTOP
1	SINEMODE	0x0	RW	Sine Mode Enable/disable sine mode.
	Value	Mode		Description
	0	DISSINEMODE		Sine mode disabled. Sine reset to 0 degrees
	1	ENSINEMODE		Sine mode enabled
0	DIFF	0x0	RW	Differential Mode Select single ended or differential mode.
	Value	Mode		Description
	0	SINGLEENDED		Single ended output
	1	DIFFERENTIAL		Differential output

28.5.5 VDAC_STATUS - Status Register

Offset	Bit Position																															
0x010	31	30	29	28	27	26	25	24	23	22	21	20	19	18	17	16	15	14	13	12	11	10	9	8	7	6	5	4	3	2	1	0
Reset	0x0	0x0	0x0	0x0	0x0	0x0			0x0	0x0		0x0	0x0			0x0			0x0				0x0	0x0			0x0	0x0			0x0	0x0
Access	R	R	R	R	R	R			R	R		R	R			R			R				R	R			R	R			R	R
Name	SYNCBUSY	ABUSALLOCERR	SINEACTIVE	ABUSINPUTCONFLICT	CH1FIFOFLBUSY	CH0FIFOFLBUSY			CH1FIFOEMPTY	CH0FIFOEMPTY		CH1CURRENTSTATE	CH0CURRENTSTATE			CH1FIFOCNT			CH0FIFOCNT				CH1FIFOFULL	CH0FIFOFULL			CH1WARM	CH0WARM			CH1ENS	CH0ENS

Bit	Name	Reset	Access	Description
31	SYNCBUSY	0x0	R	Sync Busy Combined Indicates synchronization ongoing
30	ABUSALLOCERR	0x0	R	ABUS Allocation Error Status 1 if ABUS requested is not allocated
29	SINEACTIVE	0x0	R	Sine Wave Output Status on Channel 1 indicates that sine wave output is generated on CH0 and/or CH1(in diff mode)
28	ABUSINPUTCONFLICT	0x0	R	ABUS Input Conflict Status 1 if both CH0 and CH1 request the same ABUS
27	CH1FIFOFLBUSY	0x0	R	CH1 FIFO Flush Sync Busy Indicates CH1 FIFO Flush Sync Busy
26	CH0FIFOFLBUSY	0x0	R	CH0 FIFO Flush Sync Busy Indicates CH0 FIFO Flush Sync Busy
25:24	Reserved	To ensure compatibility with future devices, always write Reserved bits to their reset value, unless otherwise stated. More information in 1.2 Conventions		
23	CH1FIFOEMPTY	0x0	R	Channel 1 FIFO Empty Status 1 if FIFO for Channel 1 is empty
22	CH0FIFOEMPTY	0x0	R	Channel 0 FIFO Empty Status 1 if FIFO for Channel 0 is empty
21	Reserved	To ensure compatibility with future devices, always write Reserved bits to their reset value, unless otherwise stated. More information in 1.2 Conventions		
20	CH1CURRENTSTATE	0x0	R	Channel 1 Current Status 0 when CH1 is in IDLE State. Set when CH1 is converting data
19	CH0CURRENTSTATE	0x0	R	Channel 0 Current Status 0 when CH0 is in IDLE State. Set when CH0 is converting data
18	Reserved	To ensure compatibility with future devices, always write Reserved bits to their reset value, unless otherwise stated. More information in 1.2 Conventions		
17:15	CH1FIFOCNT	0x0	R	Channel 1 FIFO Valid Count

Bit	Name	Reset	Access	Description
				Number of Valid Entries in Channel 1. This FIFO entries Count is generated in Read Domain hence expect Synchronization Delay. Need to be used only when VDAC_CFG.ONDEMANDCLK is set to 1.
14:12	CH0FIFOCNT	0x0	R	Channel 0 FIFO Valid Count Number of Valid Entries in Channel 0. This FIFO entries Count is generated in Read Domain hence expect Synchronization Delay. Need to be used only when VDAC_CFG.ONDEMANDCLK is set to 1.
11:10	<i>Reserved</i>	<i>To ensure compatibility with future devices, always write Reserved bits to their reset value, unless otherwise stated. More information in 1.2 Conventions</i>		
9	CH1FIFOFULL	0x0	R	Channel 1 FIFO Full Status 1 if FIFO for Channel 1 is full
8	CH0FIFOFULL	0x0	R	Channel 0 FIFO Full Status 1 if FIFO for Channel 0 is full
7:6	<i>Reserved</i>	<i>To ensure compatibility with future devices, always write Reserved bits to their reset value, unless otherwise stated. More information in 1.2 Conventions</i>		
5	CH1WARM	0x0	R	Channel 1 Warmed Status This bit is set when channel 1 has warmed up
4	CH0WARM	0x0	R	Channel 0 Warmed Status This bit is set when channel 0 has warmed up
3:2	<i>Reserved</i>	<i>To ensure compatibility with future devices, always write Reserved bits to their reset value, unless otherwise stated. More information in 1.2 Conventions</i>		
1	CH1ENS	0x0	R	Channel 1 Enabled Status This bit is set when channel 1 is enabled.
0	CH0ENS	0x0	R	Channel 0 Enabled Status This bit is set when channel 0 is enabled.

28.5.6 VDACC_CH0CFG - Channel 0 Config Register

Offset	Bit Position																																																			
0x014	31	30	29	28	27	26	25	24	23	22	21	20	19	18	17	16	15	14	13	12	11	10	9	8	7	6	5	4	3	2	1	0																				
Reset																0x0		0x0			0x0				0x0					0x0									0x0					0x0				0x0				
Access																RW		RW			RW					RW					RW																	RW			RW	
Name																KEEPWARM		HIGHCAPLOADEN			FIFODVL					REFRESHSOURCE						TRIGMODE																	POWERMODE			CONVMODE

Bit	Name	Reset	Access	Description
31:17	Reserved	To ensure compatibility with future devices, always write Reserved bits to their reset value, unless otherwise stated. More information in 1.2 Conventions		
16	KEEPWARM	0x0	RW	Channel 0 Keepwarm Mode Enable Set this bit to keep the Channel 0 on in between conversion in sample-off mode. Primary purpose of this is to reduce kickback between Channel 0 and Channel 1 and to reduce startup time.
15	Reserved	To ensure compatibility with future devices, always write Reserved bits to their reset value, unless otherwise stated. More information in 1.2 Conventions		
14	HIGHCAPLOADEN	0x0	RW	Channel 0 High Cap Load Mode Enable Enables High Capacitance Load Mode for Channel 0. Should be enabled with VDACC_CH0CFG.POWERMODE=HIGH-POWER
13	Reserved	To ensure compatibility with future devices, always write Reserved bits to their reset value, unless otherwise stated. More information in 1.2 Conventions		
12:11	FIFODVL	0x0	RW	Channel 0 FIFO Low Watermark Set Channel 0 FIFO Low Threshold Data Valid Level (DVL)
10	Reserved	To ensure compatibility with future devices, always write Reserved bits to their reset value, unless otherwise stated. More information in 1.2 Conventions		
9:8	REFRESHSOURCE	0x0	RW	Channel 0 Refresh Source Select Channel 0 Refresh Trigger
	Value	Mode	Description	
	0	NONE	No Refresh Source Selected for Channel 0.	
	1	REFRESHTIMER	Channel 0 Refresh triggered by Refresh Timer Overflow	
	2	SYNCPRS	Channel 0 Refresh triggered by Sync PRS. PRS Trigger should have the same clock group as VDAC.	
	3	ASYNCPRS	Channel 0 Refresh triggered by Async PRS	
7	Reserved	To ensure compatibility with future devices, always write Reserved bits to their reset value, unless otherwise stated. More information in 1.2 Conventions		
6:4	TRIGMODE	0x0	RW	Channel 0 Trigger Mode Select Channel 0 Conversion Trigger

Bit	Name	Reset	Access	Description
	Value	Mode		Description
	0	NONE		No Conversion Trigger Source Selected for Channel 0
	1	SW		Channel 0 is triggered by Channel 0 FIFO (CH0F) write
	2	SYNCPRS		Channel 0 is triggered by Sync PRS input. PRS Trigger should have the same clock group as VDAC.
	4	INTERNALTIMER		Channel 0 is triggered by Internal Timer Overflow
	5	ASYNCPRS		Channel 0 is triggered by Async PRS input
3	<i>Reserved</i>	<i>To ensure compatibility with future devices, always write Reserved bits to their reset value, unless otherwise stated. More information in 1.2 Conventions</i>		
2	POWERMODE	0x0	RW	Channel 0 Power Mode Enable Power Mode for Channel 0
	Value	Mode		Description
	0	HIGHPOWER		Default is High Power Mode
	1	LOWPOWER		Set this bit for Low Power Mode
1	<i>Reserved</i>	<i>To ensure compatibility with future devices, always write Reserved bits to their reset value, unless otherwise stated. More information in 1.2 Conventions</i>		
0	CONVMODE	0x0	RW	Channel 0 Conversion Mode Configure conversion mode
	Value	Mode		Description
	0	CONTINUOUS		DAC channel 0 is set in continuous mode
	1	SAMPLEOFF		DAC channel 0 is set in sample/shut off mode

28.5.7 VDAC_CH1CFG - Channel 1 Config Register

Offset	Bit Position																																																							
0x018	31	30	29	28	27	26	25	24	23	22	21	20	19	18	17	16	15	14	13	12	11	10	9	8	7	6	5	4	3	2	1	0																								
Reset																0x0		0x0			0x0				0x0					0x0									0x0					0x0			0x0									
Access																RW		RW			RW					RW																						RW			RW					
Name																KEEPWARM		HIGHCAPLOADEN			FIFODVL					REFRESHSOURCE																								TRIGMODE			POWERMODE			CONVMODE

Bit	Name	Reset	Access	Description
31:17	Reserved	To ensure compatibility with future devices, always write Reserved bits to their reset value, unless otherwise stated. More information in 1.2 Conventions		
16	KEEPWARM	0x0	RW	Channel 1 Keepwarm Mode Enable Set this bit to keep the Channel 1 on in between conversion in sample-off mode. Primary purpose of this is to reduce kickback between Channel 0 and Channel 1 and to reduce startup time.
15	Reserved	To ensure compatibility with future devices, always write Reserved bits to their reset value, unless otherwise stated. More information in 1.2 Conventions		
14	HIGHCAPLOADEN	0x0	RW	Channel 1 High Cap Load Mode Enable Enables High Capacitance Load Mode for Channel 1. Should be enabled with VDAC_CH1CFG.POWERMODE=HIGH-POWER.
13	Reserved	To ensure compatibility with future devices, always write Reserved bits to their reset value, unless otherwise stated. More information in 1.2 Conventions		
12:11	FIFODVL	0x0	RW	Channel 1 FIFO Low Watermark Set Channel 1 Low threshold Data Valid Level (DVL)
10	Reserved	To ensure compatibility with future devices, always write Reserved bits to their reset value, unless otherwise stated. More information in 1.2 Conventions		
9:8	REFRESHSOURCE	0x0	RW	Channel 1 Refresh Source Select Channel 1 Refresh Trigger
	Value	Mode	Description	
	0	NONE	No Refresh Source Selected	
	1	REFRESHTIMER	CH1 Refresh Triggered by Refresh Timer Overflow	
	2	SYNCPRS	CH1 Refresh Triggered by Sync PRS. PRS Trigger should have the same clock group as VDAC.	
	3	ASYNCPRS	CH1 Refresh Triggered by Async PRS	
7	Reserved	To ensure compatibility with future devices, always write Reserved bits to their reset value, unless otherwise stated. More information in 1.2 Conventions		
6:4	TRIGMODE	0x0	RW	Channel 1 Trigger Mode Select Channel 1 Conversion Trigger

Bit	Name	Reset	Access	Description
	Value	Mode		Description
	0	NONE		No Conversion Trigger Source Selected for Channel 1
	1	SW		Channel 1 is triggered by Channel 1 FIFO (CH1F) write
	2	SYNCPRS		Channel 1 is triggered by Sync PRS input. PRS Trigger should have the same clock group as VDAC.
	4	INTERNALTIMER		Channel 1 is triggered by Internal Timer Overflow
	5	ASYNCPRS		Channel 1 is triggered by Async PRS input
3	<i>Reserved</i>	<i>To ensure compatibility with future devices, always write Reserved bits to their reset value, unless otherwise stated. More information in 1.2 Conventions</i>		
2	POWERMODE	0x0	RW	Channel 1 Power Mode Enable Low Power Mode for Channel 1
	Value	Mode		Description
	0	HIGHPOWER		Default is High Power Mode
	1	LOWPOWER		Set this bit for Low Power Mode
1	<i>Reserved</i>	<i>To ensure compatibility with future devices, always write Reserved bits to their reset value, unless otherwise stated. More information in 1.2 Conventions</i>		
0	CONVMODE	0x0	RW	Channel 1 Conversion Mode Configure conversion mode for Channel 1
	Value	Mode		Description
	0	CONTINUOUS		DAC channel 1 is set in continuous mode
	1	SAMPLEOFF		DAC channel 1 is set in sample/shut off mode

28.5.8 VDAC_CMD - Command Register

Offset	Bit Position																																																				
0x01C	31	30	29	28	27	26	25	24	23	22	21	20	19	18	17	16	15	14	13	12	11	10	9	8	7	6	5	4	3	2	1	0																					
Reset																					0x0	0x0	0x0	0x0			0x0	0x0																									
Access																					W(nB)	W(nB)	W(nB)	W(nB)			W(nB)	W(nB)																									
Name																					SINEMODESTOP	SINEMODESTART	CH1FIFOFLUSH	CH0FIFOFLUSH																													

Bit	Name	Reset	Access	Description
31:12	<i>Reserved</i>	<i>To ensure compatibility with future devices, always write Reserved bits to their reset value, unless otherwise stated. More information in 1.2 Conventions</i>		
11	SINEMODESTOP Stop Sine Wave Generation	0x0	W(nB)	Stop Sine Wave Generation
10	SINEMODESTART Start Sine Wave Generation	0x0	W(nB)	Start Sine Wave Generation
9	CH1FIFOFLUSH Flush Channel 1 WFIFO	0x0	W(nB)	CH1 WFIFO Flush
8	CH0FIFOFLUSH Flush Channel 0 WFIFO	0x0	W(nB)	CH0 WFIFO Flush
7:6	<i>Reserved</i>	<i>To ensure compatibility with future devices, always write Reserved bits to their reset value, unless otherwise stated. More information in 1.2 Conventions</i>		
5	CH1DIS Disables DAC Channel 1	0x0	W(nB)	DAC Channel 1 Disable
4	CH1EN Enables DAC Channel 1	0x0	W(nB)	DAC Channel 1 Enable
3:2	<i>Reserved</i>	<i>To ensure compatibility with future devices, always write Reserved bits to their reset value, unless otherwise stated. More information in 1.2 Conventions</i>		
1	CH0DIS Disables DAC Channel 0	0x0	W(nB)	DAC Channel 0 Disable
0	CH0EN Enables DAC Channel 0	0x0	W(nB)	DAC Channel 0 Enable

28.5.9 VDAC_IF - Interrupt Flag Register

Offset	Bit Position																																
0x020	31	30	29	28	27	26	25	24	23	22	21	20	19	18	17	16	15	14	13	12	11	10	9	8	7	6	5	4	3	2	1	0	
Reset						0x0					0x0	0x0		0x0									0x0	0x0			0x0	0x0				0x0	0x0
Access						RW					RW	RW		RW									RW	RW			RW	RW				RW	RW
Name						ABUSINPUTCONFLICT					CH1DVL	CH0DVL		ABUSALLOCERR									CH1UF	CH0UF			CH1OF	CH0OF				CH1CD	CH0CD

Bit	Name	Reset	Access	Description
31:27	Reserved			To ensure compatibility with future devices, always write Reserved bits to their reset value, unless otherwise stated. More information in 1.2 Conventions
26	ABUSINPUTCONFLICT	0x0	RW	ABUS Input Conflict Error Flag Set if both CH0 and CH1 request same ABUS. Should only be enabled when using ABUS for VDAC Output.
25:22	Reserved			To ensure compatibility with future devices, always write Reserved bits to their reset value, unless otherwise stated. More information in 1.2 Conventions
21	CH1DVL	0x0	RW	CH1 Data Valid Level Interrupt Flag Set when Channel 1 FIFO Count reaches Data Valid Level. Also used as Wakeup IRQ
20	CH0DVL	0x0	RW	CH0 Data Valid Level Interrupt Flag Set when Channel 0 FIFO Count reaches Data Valid Level. Also used as Wakeup IRQ
19	Reserved			To ensure compatibility with future devices, always write Reserved bits to their reset value, unless otherwise stated. More information in 1.2 Conventions
18	ABUSALLOCERR	0x0	RW	ABUS Port Allocation Error Flag Set if APORT requested is not allocated. Should only be enabled when using ABUS for VDAC Output.
17:10	Reserved			To ensure compatibility with future devices, always write Reserved bits to their reset value, unless otherwise stated. More information in 1.2 Conventions
9	CH1UF	0x0	RW	CH1 Data Underflow Interrupt Flag Indicates channel 1 data underflow.
8	CH0UF	0x0	RW	CH0 Data Underflow Interrupt Flag Indicates channel 0 data underflow.
7:6	Reserved			To ensure compatibility with future devices, always write Reserved bits to their reset value, unless otherwise stated. More information in 1.2 Conventions
5	CH1OF	0x0	RW	CH1 Data Overflow Interrupt Flag Indicates channel 1 data overflow.
4	CH0OF	0x0	RW	CH0 Data Overflow Interrupt Flag Indicates channel 0 data overflow.
3:2	Reserved			To ensure compatibility with future devices, always write Reserved bits to their reset value, unless otherwise stated. More information in 1.2 Conventions

Bit	Name	Reset	Access	Description
1	CH1CD	0x0	RW	CH1 Conversion Done Interrupt Flag Indicates channel 1 conversion complete.
0	CH0CD	0x0	RW	CH0 Conversion Done Interrupt Flag Indicates channel 0 conversion complete.

28.5.10 VDAC_IEN - Interrupt Enable Register

Offset	Bit Position																																	
0x024	31	30	29	28	27	26	25	24	23	22	21	20	19	18	17	16	15	14	13	12	11	10	9	8	7	6	5	4	3	2	1	0		
Reset						0x0						0x0	0x0		0x0						0x0	0x0			0x0	0x0					0x0	0x0		
Access						RW						RW	RW		RW						RW	RW			RW	RW							RW	RW
Name						ABUSINPUTCONFLICT						CH1DVL	CH0DVL		ABUSALLOCERR						CH1UF	CH0UF			CH1OF	CH0OF							CH1CD	CH0CD

Bit	Name	Reset	Access	Description
31:27	Reserved	To ensure compatibility with future devices, always write Reserved bits to their reset value, unless otherwise stated. More information in 1.2 Conventions		
26	ABUSINPUTCONFLICT	0x0	RW	ABUS Input Conflict Interrupt Flag Set to enable the ABUSINPUTCONFLICTIF Interrupt
25:22	Reserved	To ensure compatibility with future devices, always write Reserved bits to their reset value, unless otherwise stated. More information in 1.2 Conventions		
21	CH1DVL	0x0	RW	CH1 Data Valid Level Interrupt Flag Set to enable the CH1DVLIF Interrupt
20	CH0DVL	0x0	RW	CH0 Data Valid Level Interrupt Flag Set to enable the CH0DVLIF Interrupt
19	Reserved	To ensure compatibility with future devices, always write Reserved bits to their reset value, unless otherwise stated. More information in 1.2 Conventions		
18	ABUSALLOCERR	0x0	RW	ABUS Allocation Error Interrupt Flag Set to enable the ABUSALLOCERRIF Interrupt
17:10	Reserved	To ensure compatibility with future devices, always write Reserved bits to their reset value, unless otherwise stated. More information in 1.2 Conventions		
9	CH1UF	0x0	RW	CH1 Data Underflow Interrupt Flag Set to enable the CH1UFIF Interrupt
8	CH0UF	0x0	RW	CH0 Data Underflow Interrupt Flag Set to enable the CH0UFIF Interrupt
7:6	Reserved	To ensure compatibility with future devices, always write Reserved bits to their reset value, unless otherwise stated. More information in 1.2 Conventions		
5	CH1OF	0x0	RW	CH1 Data Overflow Interrupt Flag Set to enable the CH1OFIF Interrupt
4	CH0OF	0x0	RW	CH0 Data Overflow Interrupt Flag Set to enable the CH0OFIF Interrupt
3:2	Reserved	To ensure compatibility with future devices, always write Reserved bits to their reset value, unless otherwise stated. More information in 1.2 Conventions		

Bit	Name	Reset	Access	Description
1	CH1CD	0x0	RW	CH1 Conversion Done Interrupt Flag Set to enable the CH1CDIF Interrupt
0	CH0CD	0x0	RW	CH0 Conversion Done Interrupt Flag Set to enable the CH0CDIF Interrupt

28.5.11 VDAC_CH0F - Channel 0 Data Write Fifo

Offset	Bit Position																																							
0x028	31	30	29	28	27	26	25	24	23	22	21	20	19	18	17	16	15	14	13	12	11	10	9	8	7	6	5	4	3	2	1	0								
Reset																									DATA								0x0							
Access																									DATA								W							
Name																									DATA															

Bit	Name	Reset	Access	Description
31:12	<i>Reserved</i>			<i>To ensure compatibility with future devices, always write Reserved bits to their reset value, unless otherwise stated. More information in 1.2 Conventions</i>
11:0	DATA	0x0	W	Channel 0 Data This register writes the value which will be converted by DAC channel 0 in a FIFO.

28.5.12 VDAC_CH1F - Channel 1 Data Write Fifo

Offset	Bit Position																																							
0x02C	31	30	29	28	27	26	25	24	23	22	21	20	19	18	17	16	15	14	13	12	11	10	9	8	7	6	5	4	3	2	1	0								
Reset																									DATA								0x0							
Access																									DATA								W							
Name																									DATA															

Bit	Name	Reset	Access	Description
31:12	<i>Reserved</i>			<i>To ensure compatibility with future devices, always write Reserved bits to their reset value, unless otherwise stated. More information in 1.2 Conventions</i>
11:0	DATA	0x0	W	Channel 1 Data This register writes the value which will be converted by DAC channel 1 into a FIFO

28.5.13 VDAC_OUTCTRL - DAC Output Control

Offset	Bit Position																																
0x030	31	30	29	28	27	26	25	24	23	22	21	20	19	18	17	16	15	14	13	12	11	10	9	8	7	6	5	4	3	2	1	0	
Reset				0x0					0x0					0x0					0x0					0x0	0x0			0x0	0x0			0x0	0x0
Access				RW					RW					RW					RW					RW	RW			RW	RW			RW	RW
Name				ABUSPINSELCH1					ABUSPORTSELCH1					ABUSPINSELCH0					ABUSPORTSELCH0					SHORTCH1	SHORTCH0			AUXOUTENCH1	AUXOUTENCH0			MAINOUTENCH1	MAINOUTENCH0

Bit	Name	Reset	Access	Description
31	<i>Reserved</i>	<i>To ensure compatibility with future devices, always write Reserved bits to their reset value, unless otherwise stated. More information in 1.2 Conventions</i>		
30:25	ABUSPINSELCH1	0x0	RW	CH1 ABUS Pin Select Set this to Select a particular ABUS Pin for Channel 1
24:22	ABUSPORTSELCH1	0x0	RW	CH1 ABUS Port Select Set this to Select a particular ABUS Port for Channel 1
	Value	Mode		Description
	0	NONE		No GPIO Selected for CH1 ABUS Output
	1	PORTA		Port A Selected
	2	PORTB		Port B Selected
	3	PORTC		Port C Selected
	4	PORTD		Port D Selected
21	<i>Reserved</i>	<i>To ensure compatibility with future devices, always write Reserved bits to their reset value, unless otherwise stated. More information in 1.2 Conventions</i>		
20:15	ABUSPINSELCH0	0x0	RW	CH0 ABUS Pin Select Set this to Select a particular ABUS Pin for Channel 0
14:12	ABUSPORTSELCH0	0x0	RW	CH0 ABUS Port Select Set this to Select a particular ABUS Port for Channel 0
	Value	Mode		Description
	0	NONE		No GPIO Selected for CH0 ABUS Output
	1	PORTA		Port A Selected
	2	PORTB		Port B Selected
	3	PORTC		Port C Selected
	4	PORTD		Port D Selected
11:10	<i>Reserved</i>	<i>To ensure compatibility with future devices, always write Reserved bits to their reset value, unless otherwise stated. More information in 1.2 Conventions</i>		

Bit	Name	Reset	Access	Description
9	SHORTCH1	0x0	RW	CH0 Main and Alternative Output Short Set this to short circuit Main and alternative Output of Channel 0. Usefull to connect Main and Alternative outputs together when DAC is enabled but not warmed up yet.
8	SHORTCH0	0x0	RW	CH1 Main and Alternative Output Short Set this to short circuit Main and alternative Output of Channel 1. Usefull to connect Main and Alternative outputs together when DAC is enabled but not warmed up yet.
7:6	<i>Reserved</i>	<i>To ensure compatibility with future devices, always write Reserved bits to their reset value, unless otherwise stated. More information in 1.2 Conventions</i>		
5	AUXOUTENCH1	0x0	RW	CH1 Alternative Output Enable Set this to enable alternative output of Channel 1
4	AUXOUTENCH0	0x0	RW	CH0 Alternative Output Enable Set this to enable alternative output of Channel 0
3:2	<i>Reserved</i>	<i>To ensure compatibility with future devices, always write Reserved bits to their reset value, unless otherwise stated. More information in 1.2 Conventions</i>		
1	MAINOUTENCH1	0x0	RW	CH1 Main Output Enable Set this to enable main output of Channel 1
0	MAINOUTENCH0	0x0	RW	CH0 Main Output Enable Set this to enable main output of Channel 0

28.5.14 VDAC_OUTTIMERCFG - DAC Out Timer Config Register

Offset	Bit Position																																			
0x034	31	30	29	28	27	26	25	24	23	22	21	20	19	18	17	16	15	14	13	12	11	10	9	8	7	6	5	4	3	2	1	0				
Reset																	0x0																0x0			
Access																	RW																RW			
Name																	CH1OUTHOLDTIME																CH0OUTHOLDTIME			

Bit	Name	Reset	Access	Description
31:25	<i>Reserved</i>	<i>To ensure compatibility with future devices, always write Reserved bits to their reset value, unless otherwise stated. More information in 1.2 Conventions</i>		
24:15	CH1OUTHOLDTIME	0x0	RW	CH1 Output Hold Time Number of prescaled CLK_DAC cycles to drive the output of VDAC for Channel 1
14:10	<i>Reserved</i>	<i>To ensure compatibility with future devices, always write Reserved bits to their reset value, unless otherwise stated. More information in 1.2 Conventions</i>		
9:0	CH0OUTHOLDTIME	0x0	RW	CH0 Output Hold Time Number of prescaled CLK_DAC cycles to drive the output of VDAC for Channel 0

29. ACMP - Analog Comparator

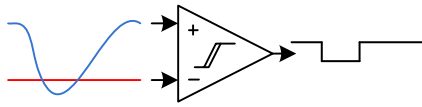
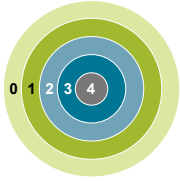

Quick Facts

What?

The ACMP (Analog Comparator) compares two analog signals and returns a digital value telling which is greater.

Why?

Applications often do not need to know the exact value of an analog signal, only if it has passed a certain threshold. Often the voltage must be monitored continuously, which requires extremely low power consumption.

How?

Available down to Energy Mode 3, the ACMP can wake up the system when input signals pass the threshold. The analog comparator can compare two analog signals or one analog signal and a highly configurable internal reference.

29.1 Introduction

The Analog Comparator compares the voltage of two analog inputs and outputs a digital signal indicating which input voltage is higher. Inputs can either be from internal references or from external pins. Response time, and thereby the current consumption, can be configured by altering the current supply to the comparator.

29.2 Features

- Internal and external input selections:
 - External port I/O routed via ABUS
 - Internal 1.25 V bandgap reference voltage with programmable divider
 - Internal 2.5 V bandgap reference voltage with programmable divider
 - AVDD supply voltage with programmable divider
 - VDAC auxiliary outputs
- Voltage supply monitoring
- Configurable hysteresis
- Selectable response time
- Operational in EM0 to EM3
- Asynchronous interrupt generation on selectable edges
- Configurable output state when inactive
- Output routing options:
 - Route to GPIO via DBUS
 - Route to most peripherals via PRS

29.3 Functional Description

An overview of the ACMP is shown in [Figure 29.1 ACMP Overview](#) on page 1110.

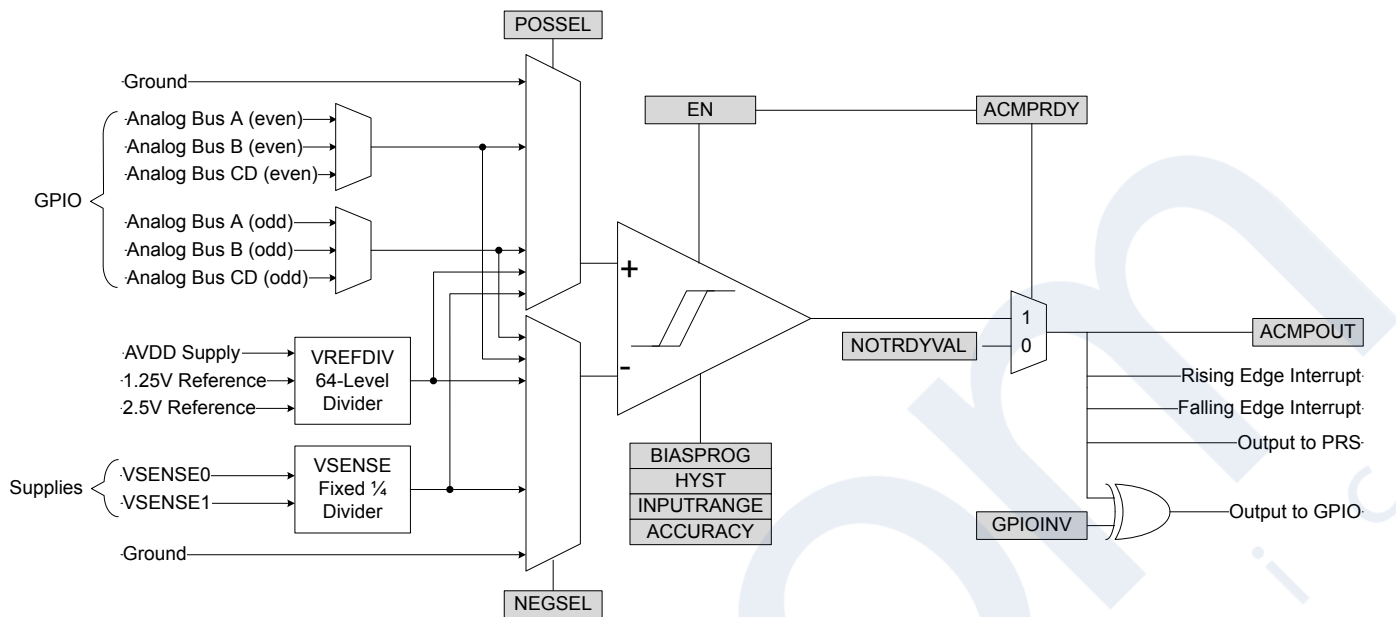

Figure 29.1. ACMP Overview

The comparator has two analog inputs: one positive and one negative. When the comparator is active, the output indicates which of the two input voltages is higher. When the voltage on the positive input is higher than the voltage on the negative input, the digital output is high and vice versa.

In addition to the comparator core, the ACMP front-end includes reference sources, voltage divider circuits, and input muxes to route signals to the positive and negative inputs. The output from the ACMP is available on both PRS and GPIO, in addition to being observable in the ACMP_STATUS register.

29.3.1 Configuration and Control

The ACMP is configured and controlled through three registers: ACMP_CFG, ACMP_CTRL, and ACMP_INPUTCTRL. Configuration through ACMP_CFG needs to happen before the ACMP is enabled. The control registers ACMP_CTRL and ACMP_INPUTCTRL can only be updated after the ACMP is enabled. The ACMP is enabled by setting the EN bit in ACMP_EN. If ACMP_CFG is updated when EN = 1, or ACMP_CTRL / ACMP_INPUTCTRL is updated while EN = 0, a bus fault is issued.

The input muxes are configured in the POSSEL / NEGSEL bitfields in ACMP_INPUTCTRL. All references and inputs are available in the modes defined for these two registers. The INPUTCTRL bit in ACMP_SYNCBUSY should be checked before writing to ACMP_INPUTCTRL. If the ACMP_SYNCBUSY_INPUTCTRL bit is 1, it means a previous write to the ACMP_INPUTCTRL register is pending, and software should wait until ACMP_SYNCBUSY_INPUTCTRL bit reads 0.

The POSSEL and NEGSEL muxes share several resources on the device, such as the VREFDIV and VSENSE divider circuits. Thus, there are some constraints on the POSSEL / NEGSEL configurations:

- POSSEL and NEGSEL cannot select an even numbered GPIO pin at the same time.
- POSSEL and NEGSEL cannot select an odd numbered GPIO pin at the same time.
- POSSEL and NEGSEL cannot both select a supply voltage via one of the VSENSE inputs.
- POSSEL and NEGSEL cannot both select an input using VREFDIV.
- If POSSEL = EXTPx, a low power reference (postfixed with LP) cannot be selected for NEGSEL.

If one of these constraints are violated, the INPUTCONFLICT status flag and INPUTCONFLICTIF interrupt flag will be set.

The ACMP also uses shared chip-level analog bus resources to connect to external GPIO pins. Which bus the ACMP is using depends on the configuration of POSSEL and NEGSEL. To allow the ACMP to control an analog bus, the bus must be allocated to ACMP in the GPIO module, using the GPIO_xBUSALLOC registers. For example, pin PB5 is an odd-numbered pin on port PB, and could connect via either analog bus BODD0 or BODD1. This is configured using the BODD0 or BODD1 field in GPIO_BBUSALLOC.

If the ACMP peripheral is trying to access a bus that has not been allocated to that instance of ACMP, the PORTALLOCERR status flag and PORTALLOCERRIF interrupt flag will be set.

29.3.2 Warmup Time

When the comparator is enabled or the input muxes are reconfigured, it requires some time to stabilize. On first enable (ACMP_EN_EN = 1), the comparator core requires 2.5 us to stabilize. In addition to this, any references selected may require some time to warm up. See [Table 29.1 Warmup Time on page 1111](#) for warmup times for the different references. When reconfiguring the ACMP (without disabling it), only the warmup times given in the table will be observed. When the comparator is ready for use, the ACMPRDY status flag and the ACMPRDY interrupt flag will be set.

Note: The hardware timeout is not sufficient to ensure glitch-free operation when using BIAS<=3. To avoid startup glitches, software should wait for 60 us after enabling the comparator to use the output.

During the warmup time and when the comparator is inactive, the comparator output will be set to the state defined by the NOTRDYVAL bit in ACMP_CTRL.

Table 29.1. Warmup Time

Reference	Warmup time
Low power reference: POSSEL / NEGSEL = *LP	10 us
VSENSE: POSSEL / NEGSEL = VSENSE*	5 us
VREF: POSSEL / NEGSEL = VREF*	2 us
None of the above	0.5 us

29.3.3 Response Time

There is a delay from when the input voltage changes polarity to when the output toggles. This delay is called the response time and can be altered by increasing or decreasing the bias current to the comparator through the BIASPROG bitfield in the ACMP_CFG register. The current and speed of the circuit increase as the value of BIASPROG is increased. See the part datasheet for specific current and response times related to setting of BIASPROG.

29.3.4 Hysteresis

When the hysteresis level is set to a non-zero value, the digital output will not toggle until the positive input voltage is at a voltage equal to the hysteresis level above or below the negative input voltage (see [Figure 29.2 Hysteresis on page 1112](#)). This feature can be used to avoid continual comparator output changes due to input noise when the positive and negative inputs are similar. Hysteresis requires the input difference to exceed the hysteresis threshold before the output can change and can reject limited amounts of noise. The hysteresis in ACMP can be configured to three different levels (10 mV, 20 mV, 30 mV), and can be enabled on positive (rising), negative (falling), or both edges. Hysteresis is configured in the HYST bitfield in ACMP_CFG.

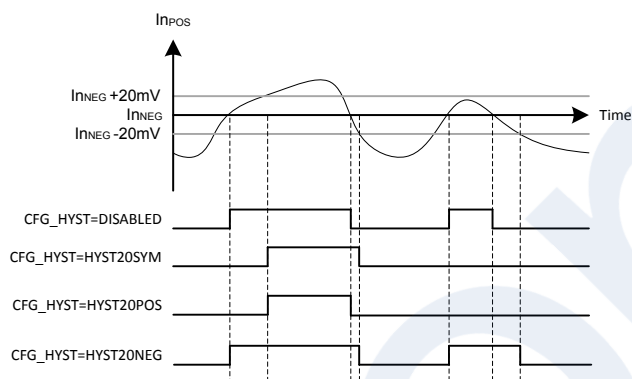

Figure 29.2. Hysteresis

29.3.5 Supply Voltage Monitoring (VSENSE)

The ACMP can be used to monitor supply voltages. This is done by selecting VSENSE01DIV4(LP) or VSENSE11DIV4(LP) for either POSSEL or NEGSEL. Note that the input to the comparator core will be divided by 4, as illustrated in [Figure 29.1 ACMP Overview on page 1110](#). To reduce energy consumption, a sample/hold circuit can be used to periodically sample the power supplies. To enable this, select VSENSE01DIV4LP or VSENSE11DIV4LP in POSSEL / NEGSEL. Because the sample/hold feature uses the comparator in a non-continuous fashion, enabling this will increase response times and reduce the accuracy of the comparator. The connections between VSENSE0 and VSENSE1 to power supplies are summarized in the table below.

Table 29.2. VSENSE connections

ACMP instance	VSENSE0	VSENSE1
ACMP0	AVDD	VDDIO0
ACMP1	DVDD	Not connected

29.3.6 VREFDIV Sources

The ACMP has two internal bandgap references: 2.5 V and 1.25 V. In addition, AVDD can be used as a reference. To select one of these references, configure POSSEL / NEGSEL to VREFDIVAVDD, VREFDIV1V25, or VREFDIV2V5. The ACMP also includes sample/hold functionality to reduce energy consumption. To enable the sample/hold feature, select VREFDIVAVDDL, VREFDIV1V25LP, or VREFDIV2V5LP. These references can be divided by configuring VREFDIV in ACMP_INPUTCTRL. This division factor will be VREFDIV / 63, such that VREFOUT = VREFIN * (VREFDIV / 63).

29.3.7 Input Range and Accuracy Settings

By default, the ACMP can accept external rail-to-rail inputs, from 0 to AVDD. If external voltages will never be higher than AVDD - 0.7 V, the INPUTRANGE bit in ACMP_CFG can be set to 1 to reduce the power consumption of the block.

The ACMP also has an adjustable accuracy setting (ACCURACY in ACMP_CFG). ACCURACY is set to LOW by default, which conserves power, but may have degraded performance for rapidly changing analog Port selections in either the ACMP or the GPIO. ACCURACY can be set to HIGH to insure ACMP accuracy (at the expense of extra power consumption), when configuration changes are expected at a high rate (more than once per ms, for example), such as when scanning through channels.

29.3.8 Interrupts and PRS Output

The analog comparator includes independent output flags for rising edge (RISEIF) and falling edge (FALLIF) events. These will be set when a rising or falling edge is detected, respectively.

Three other interrupt sources are also available. PORTALLOCERRIF and INPUTCONFLICTIF are input configuration error flags, detailed in [29.3.1 Configuration and Control](#). The ACMPRDYIF flag indicates comparator stability after the warmup period.

The comparator output is available as an asynchronous PRS producer, and can be routed to other peripherals in the system via PRS.

29.3.9 Output to GPIO

The output from the comparator is available as alternate functions to the GPIO pins. Each pin connection can be enabled/disabled separately using the GPIO module control registers. See the device data sheet for the available locations for each signal.

The GPIO pin must also be set as output. The output to the GPIO can be inverted by setting the GPIOINV bit in ACMP_CTRL.

29.4 ACMP Register Map

The offset register address is relative to the registers base address.

Offset	Name	Type	Description
0x000	ACMP_IPVERSION	R	IP Version ID
0x004	ACMP_EN	RW ENABLE	ACMP Enable
0x008	ACMP_SWRST	RW SWRST	Software Reset
0x00C	ACMP_CFG	RW CONFIG	Configuration Register
0x010	ACMP_CTRL	RW	Control Register
0x014	ACMP_INPUTCTRL	RW SYNC	Input Control Register
0x018	ACMP_STATUS	RH	Status Register
0x01C	ACMP_IF	RWH INTFLAG	Interrupt Flag Register
0x020	ACMP_IEN	RW	Interrupt Enable Register
0x024	ACMP_SYNCBUSY	RH	Syncbusy
0x1000	ACMP_IPVERSION_SET	R	IP Version ID
0x1004	ACMP_EN_SET	RW ENABLE	ACMP Enable
0x1008	ACMP_SWRST_SET	RW SWRST	Software Reset
0x100C	ACMP_CFG_SET	RW CONFIG	Configuration Register
0x1010	ACMP_CTRL_SET	RW	Control Register
0x1014	ACMP_INPUTCTRL_SET	RW SYNC	Input Control Register
0x1018	ACMP_STATUS_SET	RH	Status Register
0x101C	ACMP_IF_SET	RWH INTFLAG	Interrupt Flag Register
0x1020	ACMP_IEN_SET	RW	Interrupt Enable Register
0x1024	ACMP_SYNCBUSY_SET	RH	Syncbusy
0x2000	ACMP_IPVERSION_CLR	R	IP Version ID
0x2004	ACMP_EN_CLR	RW ENABLE	ACMP Enable
0x2008	ACMP_SWRST_CLR	RW SWRST	Software Reset
0x200C	ACMP_CFG_CLR	RW CONFIG	Configuration Register
0x2010	ACMP_CTRL_CLR	RW	Control Register
0x2014	ACMP_INPUTCTRL_CLR	RW SYNC	Input Control Register
0x2018	ACMP_STATUS_CLR	RH	Status Register
0x201C	ACMP_IF_CLR	RWH INTFLAG	Interrupt Flag Register
0x2020	ACMP_IEN_CLR	RW	Interrupt Enable Register
0x2024	ACMP_SYNCBUSY_CLR	RH	Syncbusy
0x3000	ACMP_IPVERSION_TGL	R	IP Version ID
0x3004	ACMP_EN_TGL	RW ENABLE	ACMP Enable
0x3008	ACMP_SWRST_TGL	RW SWRST	Software Reset
0x300C	ACMP_CFG_TGL	RW CONFIG	Configuration Register
0x3010	ACMP_CTRL_TGL	RW	Control Register

Offset	Name	Type	Description
0x3014	ACMP_INPUTCTRL_TGL	RW SYNC	Input Control Register
0x3018	ACMP_STATUS_TGL	RH	Status Register
0x301C	ACMP_IF_TGL	RWH INTFLAG	Interrupt Flag Register
0x3020	ACMP_IEN_TGL	RW	Interrupt Enable Register
0x3024	ACMP_SYNCBUSY_TGL	RH	Syncbusy

29.5 ACMP Register Description

29.5.1 ACMP_IPVERSION - IP Version ID

Offset	Bit Position																															
0x000	31	30	29	28	27	26	25	24	23	22	21	20	19	18	17	16	15	14	13	12	11	10	9	8	7	6	5	4	3	2	1	0
Reset																	0x2															
Access																	R															
Name																	IPVERSION															

Bit	Name	Reset	Access	Description
31:0	IPVERSION	0x2	R	IP version ID

29.5.2 ACMP_EN - ACMP Enable

Offset	Bit Position																															
0x004	31	30	29	28	27	26	25	24	23	22	21	20	19	18	17	16	15	14	13	12	11	10	9	8	7	6	5	4	3	2	1	0
Reset																															0x0	0x0
Access																															R	RW
Name																															DISABLING	EN

Bit	Name	Reset	Access	Description
31:2	Reserved	To ensure compatibility with future devices, always write Reserved bits to their reset value, unless otherwise stated. More information in 1.2 Conventions		
1	DISABLING	0x0	R	Disablement busy status When En is cleared, DISABLING is set immediately, and cleared when disablement finishes. Disablement resets peripheral cores and not APB registers except hardware updated registers such as INTFLAGS and FIFOs.
0	EN	0x0	RW	Module enable The ENABLE bit enables the module. Software should write to CONFIG type registers before setting the ENABLE bit. Software should write to SYNC type registers only after setting the ENABLE bit.

29.5.3 ACMP_SWRST - Software Reset

Offset	Bit Position																															
0x008	31	30	29	28	27	26	25	24	23	22	21	20	19	18	17	16	15	14	13	12	11	10	9	8	7	6	5	4	3	2	1	0
Reset																															0x0	0x0
Access																															R	W
Name																															RESETTING	SWRST

Bit	Name	Reset	Access	Description
31:2	Reserved	To ensure compatibility with future devices, always write Reserved bits to their reset value, unless otherwise stated. More information in 1.2 Conventions		
1	RESETTING	0x0	R	Software reset busy status
0	SWRST	0x0	W	Software reset

29.5.4 ACMP_CFG - Configuration Register

Offset	Bit Position																																
0x00C	31	30	29	28	27	26	25	24	23	22	21	20	19	18	17	16	15	14	13	12	11	10	9	8	7	6	5	4	3	2	1	0	
Reset																0x0	0x0							0x0								0x4	
Access																RW	RW							RW								RW	
Name																ACCURACY	INPUTRANGE							HYST								BIAS	

Bit	Name	Reset	Access	Description
31:18	<i>Reserved</i>	<i>To ensure compatibility with future devices, always write Reserved bits to their reset value, unless otherwise stated. More information in 1.2 Conventions</i>		
17	ACCURACY	0x0	RW	ACMP accuracy mode Setting ACCURACY to HIGH reduces the noise in the signal input path of the ACMP. Note, high frequency changes can cause the ACMP performance to degrade. For such uses, such as quickly scanning through multiple channels, this should be set to HIGH.
	Value	Mode	Description	
	0	LOW	ACMP operates in low-accuracy mode but consumes less current.	
	1	HIGH	ACMP operates in high-accuracy mode but consumes more current.	
16	INPUTRANGE	0x0	RW	Input Range Adjust performance of the comparator for a given input voltage range.
	Value	Mode	Description	
	0	FULL	Use this setting when the input to the comparator core can be from 0 to AVDD.	
	1	REDUCED	It is recommended to use this setting when the input to the comparator core will always be less than AVDD-0.7V.	
15:12	<i>Reserved</i>	<i>To ensure compatibility with future devices, always write Reserved bits to their reset value, unless otherwise stated. More information in 1.2 Conventions</i>		
11:8	HYST	0x0	RW	Hysteresis mode Set hysteresis mode and level.
	Value	Mode	Description	
	0	DISABLED	Hysteresis disabled	
	1	SYM10MV	10mV symmetrical hysteresis	
	2	SYM20MV	20mV symmetrical hysteresis	
	3	SYM30MV	30mV symmetrical hysteresis	
	4	POS10MV	10mV hysteresis on positive edge transitions	
	5	POS20MV	20mV hysteresis on positive edge transitions	

Bit	Name	Reset	Access	Description
6		POS30MV		30mV hysteresis on positive edge transitions
8		NEG10MV		10mV hysteresis on negative edge transitions
9		NEG20MV		20mV hysteresis on negative edge transitions
10		NEG30MV		30mV hysteresis on negative edge transitions
7:3	<i>Reserved</i>	<i>To ensure compatibility with future devices, always write Reserved bits to their reset value, unless otherwise stated. More information in 1.2 Conventions</i>		
2:0	BIAS	0x4	RW	Bias Configuration These bits control the bias current level. See the datasheet for details.

29.5.5 ACMP_CTRL - Control Register

Offset	Bit Position																															
0x010	31	30	29	28	27	26	25	24	23	22	21	20	19	18	17	16	15	14	13	12	11	10	9	8	7	6	5	4	3	2	1	0
Reset																											0x0	0x0				
Access																											RW	RW				
Name																											GPIOINV	NOTRDYVAL				

Bit	Name	Reset	Access	Description									
31:2	<i>Reserved</i>	<i>To ensure compatibility with future devices, always write Reserved bits to their reset value, unless otherwise stated. More information in 1.2 Conventions</i>											
1	GPIOINV	0x0	RW	Comparator GPIO Output Invert Set this bit to 1 to invert the comparator alternate function output to GPIO. <table border="1"> <thead> <tr> <th>Value</th> <th>Mode</th> <th>Description</th> </tr> </thead> <tbody> <tr> <td>0</td> <td>NOTINV</td> <td>The comparator output to GPIO is not inverted</td> </tr> <tr> <td>1</td> <td>INV</td> <td>The comparator output to GPIO is inverted</td> </tr> </tbody> </table>	Value	Mode	Description	0	NOTINV	The comparator output to GPIO is not inverted	1	INV	The comparator output to GPIO is inverted
Value	Mode	Description											
0	NOTINV	The comparator output to GPIO is not inverted											
1	INV	The comparator output to GPIO is inverted											
0	NOTRDYVAL	0x0	RW	Not Ready Value The value of this bit is used as the comparator output when the comparator is not ready. <table border="1"> <thead> <tr> <th>Value</th> <th>Mode</th> <th>Description</th> </tr> </thead> <tbody> <tr> <td>0</td> <td>LOW</td> <td>ACMP output is 0 when the ACMP is not ready.</td> </tr> <tr> <td>1</td> <td>HIGH</td> <td>ACMP output is 1 when the ACMP is not ready.</td> </tr> </tbody> </table>	Value	Mode	Description	0	LOW	ACMP output is 0 when the ACMP is not ready.	1	HIGH	ACMP output is 1 when the ACMP is not ready.
Value	Mode	Description											
0	LOW	ACMP output is 0 when the ACMP is not ready.											
1	HIGH	ACMP output is 1 when the ACMP is not ready.											

29.5.6 ACMP_INPUTCTRL - Input Control Register

Offset	Bit Position																																
0x014	31	30	29	28	27	26	25	24	23	22	21	20	19	18	17	16	15	14	13	12	11	10	9	8	7	6	5	4	3	2	1	0	
Reset			0x0										0x0							0x0									0x0				
Access			RW										RW							RW									RW				
Name			CSRESSEL										VREFDIV							NEGSEL									POSSEL				

Bit	Name	Reset	Access	Description
31	<i>Reserved</i>	<i>To ensure compatibility with future devices, always write Reserved bits to their reset value, unless otherwise stated. More information in 1.2 Conventions</i>		
30:28	CSRESSEL	0x0	RW	Capacitive Sense Mode Internal Resistor Deprecated capacitive sensing feature, not recommended for new designs
	Value	Mode	Description	
	0	RES0	Internal capacitive sense resistor value 0	
	1	RES1	Internal capacitive sense resistor value 1	
	2	RES2	Internal capacitive sense resistor value 2	
	3	RES3	Internal capacitive sense resistor value 3	
	4	RES4	Internal capacitive sense resistor value 4	
	5	RES5	Internal capacitive sense resistor value 5	
	6	RES6	Internal capacitive sense resistor value 6	
27:22	<i>Reserved</i>	<i>To ensure compatibility with future devices, always write Reserved bits to their reset value, unless otherwise stated. More information in 1.2 Conventions</i>		
21:16	VREFDIV	0x0	RW	VREF division Set division factor for VREFDIV. $VREFOUT = VREFIN * (VREFDIV / 63)$
15:8	NEGSEL	0x0	RW	Negative Input Select Select negative input.
	Value	Mode	Description	
	0	VSS	VSS	
	16	VREFDIVAVDD	Divided AVDD	
	17	VREFDIVAVDDL	Low-Power Divided AVDD	
	18	VREFDIV1V25	Divided 1V25 reference	
	19	VREFDIV1V25LP	Low-power Divided 1V25 reference	
	20	VREFDIV2V5	Divided 2V5 reference	
	21	VREFDIV2V5LP	Low-power Divided 2V5 reference	
	32	VSENSE0DIV4	VSENSE0 divided by 4	
	33	VSENSE0DIV4LP	Low-power VSENSE0 divided by 4	

Bit	Name	Reset	Access	Description
34		VSENSE11DIV4		VSENSE1 divided by 4
35		VSENSE11DIV4LP		Low-power VSENSE1 divided by 4
48		CAPSENSE		Deprecated capacitive sensing feature, not recommended for new designs
64		VDAC0OUT0		VDAC0 channel 0 output
66		VDAC1OUT0		VDAC1 channel 0 output
128		PA0		Port A, Pin0
129		PA1		Port A, Pin1
130		PA2		Port A, Pin2
131		PA3		Port A, Pin3
132		PA4		Port A, Pin4
133		PA5		Port A, Pin5
134		PA6		Port A, Pin6
135		PA7		Port A, Pin7
136		PA8		Port A, Pin8
137		PA9		Port A, Pin9
138		PA10		Port A, Pin10
139		PA11		Port A, Pin11
140		PA12		Port A, Pin12
141		PA13		Port A, Pin13
142		PA14		Port A, Pin14
143		PA15		Port A, Pin15
144		PB0		Port B, Pin0
145		PB1		Port B, Pin1
146		PB2		Port B, Pin2
147		PB3		Port B, Pin3
148		PB4		Port B, Pin4
149		PB5		Port B, Pin5
150		PB6		Port B, Pin6
151		PB7		Port B, Pin7
152		PB8		Port B, Pin8
153		PB9		Port B, Pin9
154		PB10		Port B, Pin10
155		PB11		Port B, Pin11
156		PB12		Port B, Pin12
157		PB13		Port B, Pin13
158		PB14		Port B, Pin14

Bit	Name	Reset	Access	Description
159		PB15		Port B, Pin15
160		PC0		Port C, Pin0
161		PC1		Port C, Pin1
162		PC2		Port C, Pin2
163		PC3		Port C, Pin3
164		PC4		Port C, Pin4
165		PC5		Port C, Pin5
166		PC6		Port C, Pin6
167		PC7		Port C, Pin7
168		PC8		Port C, Pin8
169		PC9		Port C, Pin9
170		PC10		Port C, Pin10
171		PC11		Port C, Pin11
172		PC12		Port C, Pin12
173		PC13		Port C, Pin13
174		PC14		Port C, Pin14
175		PC15		Port C, Pin15
176		PD0		Port D, Pin0
177		PD1		Port D, Pin1
178		PD2		Port D, Pin2
179		PD3		Port D, Pin3
180		PD4		Port D, Pin4
181		PD5		Port D, Pin5
182		PD6		Port D, Pin6
183		PD7		Port D, Pin7
184		PD8		Port D, Pin8
185		PD9		Port D, Pin9
186		PD10		Port D, Pin10
187		PD11		Port D, Pin11
188		PD12		Port D, Pin12
189		PD13		Port D, Pin13
190		PD14		Port D, Pin14
191		PD15		Port D, Pin15
7:0	POSSEL	0x0	RW	Positive Input Select Select positive input.
	Value	Mode		Description

Bit	Name	Reset	Access	Description
0		VSS		VSS
16		VREFDIVAVDD		Divided AVDD
17		VREFDIVAVDDL		Low-Power Divided AVDD
18		VREFDIV1V25		Divided 1V25 reference
19		VREFDIV1V25LP		Low-power Divided 1V25 reference
20		VREFDIV2V5		Divided 2V5 reference
21		VREFDIV2V5LP		Low-power Divided 2V5 reference
32		VSENSE0DIV4		VSENSE0 divided by 4
33		VSENSE0DIV4LP		Low-power VSENSE0 divided by 4
34		VSENSE1DIV4		VSENSE1 divided by 4
35		VSENSE1DIV4LP		Low-power VSENSE1 divided by 4
65		VDAC0OUT1		VDAC0 channel 1 output
67		VDAC1OUT1		VDAC1 channel 1 output
80		EXTPA		External interface, base is PA0.
81		EXTPB		External interface, base is PB0.
82		EXTPC		External interface, base is PC0.
83		EXTPD		External interface, base is PD0.
128		PA0		Port A, Pin0
129		PA1		Port A, Pin1
130		PA2		Port A, Pin2
131		PA3		Port A, Pin3
132		PA4		Port A, Pin4
133		PA5		Port A, Pin5
134		PA6		Port A, Pin6
135		PA7		Port A, Pin7
136		PA8		Port A, Pin8
137		PA9		Port A, Pin9
138		PA10		Port A, Pin10
139		PA11		Port A, Pin11
140		PA12		Port A, Pin12
141		PA13		Port A, Pin13
142		PA14		Port A, Pin14
143		PA15		Port A, Pin15
144		PB0		Port B, Pin0
145		PB1		Port B, Pin1
146		PB2		Port B, Pin2
147		PB3		Port B, Pin3

Bit	Name	Reset	Access	Description
148		PB4		Port B, Pin4
149		PB5		Port B, Pin5
150		PB6		Port B, Pin6
151		PB7		Port B, Pin7
152		PB8		Port B, Pin8
153		PB9		Port B, Pin9
154		PB10		Port B, Pin10
155		PB11		Port B, Pin11
156		PB12		Port B, Pin12
157		PB13		Port B, Pin13
158		PB14		Port B, Pin14
159		PB15		Port B, Pin15
160		PC0		Port C, Pin0
161		PC1		Port C, Pin1
162		PC2		Port C, Pin2
163		PC3		Port C, Pin3
164		PC4		Port C, Pin4
165		PC5		Port C, Pin5
166		PC6		Port C, Pin6
167		PC7		Port C, Pin7
168		PC8		Port C, Pin8
169		PC9		Port C, Pin9
170		PC10		Port C, Pin10
171		PC11		Port C, Pin11
172		PC12		Port C, Pin12
173		PC13		Port C, Pin13
174		PC14		Port C, Pin14
175		PC15		Port C, Pin15
176		PD0		Port D, Pin0
177		PD1		Port D, Pin1
178		PD2		Port D, Pin2
179		PD3		Port D, Pin3
180		PD4		Port D, Pin4
181		PD5		Port D, Pin5
182		PD6		Port D, Pin6
183		PD7		Port D, Pin7
184		PD8		Port D, Pin8

Bit	Name	Reset	Access	Description
185		PD9		Port D, Pin9
186		PD10		Port D, Pin10
187		PD11		Port D, Pin11
188		PD12		Port D, Pin12
189		PD13		Port D, Pin13
190		PD14		Port D, Pin14
191		PD15		Port D, Pin15

29.5.7 ACMP_STATUS - Status Register

Offset	Bit Position																																
0x018	31	30	29	28	27	26	25	24	23	22	21	20	19	18	17	16	15	14	13	12	11	10	9	8	7	6	5	4	3	2	1	0	
Reset																													0x0	0x0	0x0		0x0
Access																													R	R	R		R
Name																													PORTALLOCERR	INPUTCONFLICT	ACMPRDY		ACMPOUT

Bit	Name	Reset	Access	Description
31:5	<i>Reserved</i>	<i>To ensure compatibility with future devices, always write Reserved bits to their reset value, unless otherwise stated. More information in 1.2 Conventions</i>		
4	PORTALLOCERR	0x0	R	Port allocation error The port selected by INPUTCTRL_POSSEL or INPUTCTRL_NEGSEL is not allocated to this ACMP. Port allocation needs to be configured in the GPIO module.
3	INPUTCONFLICT	0x0	R	INPUT conflict INPUTCTRL_POSSEL and INPUTCTRL_NEGSEL is configured illegally.
2	ACMPRDY	0x0	R	Analog Comparator Ready Analog comparator ready status.
1	<i>Reserved</i>	<i>To ensure compatibility with future devices, always write Reserved bits to their reset value, unless otherwise stated. More information in 1.2 Conventions</i>		
0	ACMPOUT	0x0	R	Analog Comparator Output Analog comparator output value.

29.5.9 ACMP_IEN - Interrupt Enable Register

Offset	Bit Position																															
0x020	31	30	29	28	27	26	25	24	23	22	21	20	19	18	17	16	15	14	13	12	11	10	9	8	7	6	5	4	3	2	1	0
Reset																											0x0	0x0	0x0	0x0	0x0	0x0
Access																											RW	RW	RW	RW	RW	RW
Name																											PORTALLOCERR	INPUTCONFLICT	ACMPRDY	FALL	RISE	

Bit	Name	Reset	Access	Description
31:5	Reserved	<i>To ensure compatibility with future devices, always write Reserved bits to their reset value, unless otherwise stated. More information in 1.2 Conventions</i>		
4	PORTALLOCERR	0x0	RW	Port allocation error interrupt enable
3	INPUTCONFLICT	0x0	RW	Input conflict interrupt enable
2	ACMPRDY	0x0	RW	ACMP ready interrupt enable
1	FALL	0x0	RW	Falling edge interrupt enable
0	RISE	0x0	RW	Rising edge interrupt enable

29.5.10 ACMP_SYNCBUSY - Syncbusy

Offset	Bit Position																															
0x024	31	30	29	28	27	26	25	24	23	22	21	20	19	18	17	16	15	14	13	12	11	10	9	8	7	6	5	4	3	2	1	0
Reset																											0x0					
Access																											R					
Name																											INPUTCTRL					

Bit	Name	Reset	Access	Description
31:1	Reserved	<i>To ensure compatibility with future devices, always write Reserved bits to their reset value, unless otherwise stated. More information in 1.2 Conventions</i>		
0	INPUTCTRL	0x0	R	Syncbusy for INPUTCTRL Synchronization of INPUTCTRL ongoing

30. KEYSCAN - Keyboard Scan

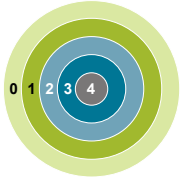

Quick Facts

What?

The keypad scanner autonomously scans through a matrix of keypad switches to detect key presses.

Why?

Operating independently from the main processor, the keypad scanner can save energy by interrupting the system only as needed. The KEYSCAN peripheral also saves energy by operating in a wake-on-press mode in EM2 and EM3.

How?

A traditional row/column matrix of switches is scanned using a finite state machine capable of debouncing and settling any key press prior to processor intervention.

30.1 Introduction

The KEYSCAN module connects through row and column GPIOs to an external mechanical keypad. The KEYSCAN supports up to 6 rows and up to 8 columns.

30.2 Features

- Performs scans in EM0 / EM1 to detect the row and column address of any key
- Wake up from sleep on key press in EM2 / EM3
- Supports up to a 6 x 8 matrix of keys in one or more keypads
- Interrupt sources for detected key press and non-press
- Multi-touch mode available for detecting multiple simultaneous keys

30.3 Functional Description

An overview of the KEYSCAN module is shown in [Figure 30.1 KEYSCAN Overview on page 1128](#). The KEYSCAN consists of rows and columns GPIOs connected to the KEYSCAN hardware. In EM0 and EM1, KEYSCAN can actively scan all switches in the matrix for active key presses. Any closed switches between rows and columns are detected, debounced, settled, and reported to the processor via the register interface. In EM2 and EM3, KEYSCAN simultaneously checks for any key press across the entire switch matrix. Any press will wake to an active state, allowing KEYSCAN to perform a scan and determine specific key location(s).

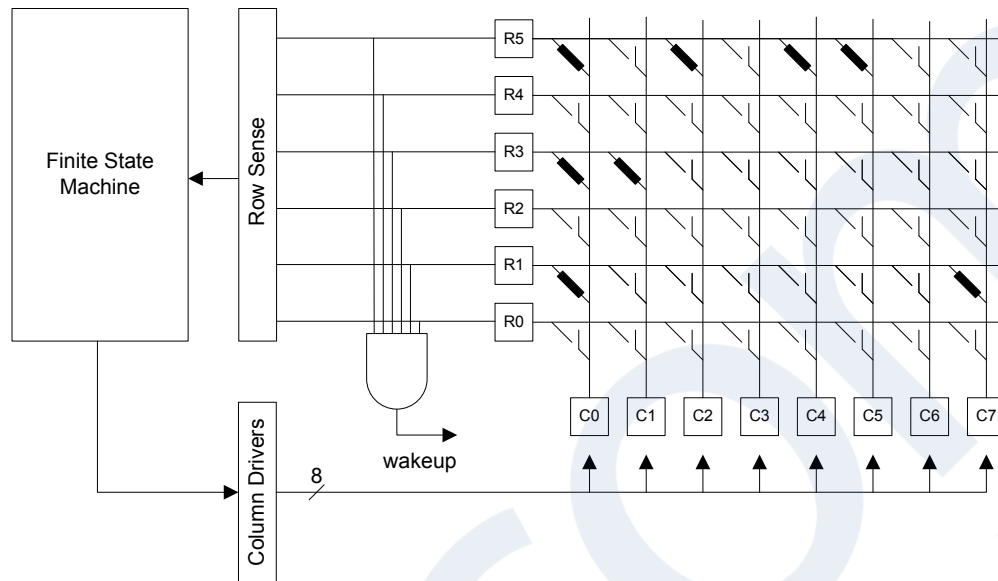

Figure 30.1. KEYSCAN Overview

30.3.1 Row and Column Configuration

Row and column signals are routed to physical pins using DBUS and set up in the GPIO configuration registers.

Columns are the output drivers and can be routed to any available port pin using the `GPIO_KEYSCAN_COLOUTxROUTE` register, where 'x' is the column number. Column outputs must also be individually enabled using the bits in `GPIO_KEYSCAN_ROUTEN`.

Rows are the input sense circuitry. They are routed via the `GPIO_KEYSCAN_ROWSENSExROUTE` registers, where 'x' is the row number. Row signals are only available on ports A and B.

Rows and columns should be routed starting at the lowest number. For example, a keypad requiring 3 rows and 2 columns should route `ROW0`, `ROW1`, `ROW2`, `COL0`, and `COL1`.

When the GPIO registers have been configured, the `KEYSCAN_CFG.NUMROWS` and `KEYSCAN_CFG.NUMCOLS` can then be configured to indicate the number of rows and columns to include in each scan.

30.3.2 Clocking and Timing

The timebase for the KEYSCAN peripheral is derived from `EM01GRPACLK`. The `CFG.CLKDIV` field should be used to divide `EM01GRPACLK` to produce a 500 Hz clock (2 ms ticks), which drives the timing of delays in the KEYSCAN state machine.

There are three timed delays used in the state machine, which are described in more detail in the following sections. Timing for these delays is configured by the `SCANDLY`, `DEBDLY`, and `STABDLY` fields in the `DELAY` register. Each of these fields specifies the number of 2 ms clock ticks for a different delay, with a range from 2 ms to 32 ms.

30.3.3 Scanning

Figure 30.2 [KEYSCAN State Machine on page 1129](#) shows the state machine sequence for key press scanning. When a scanning sequence begins, the scan logic grounds one column at a time, starting with column 0. The column pin is grounded for up to `DELAY.SCANDLY` clocks. If no rows are detected as low (indicating a key press) the scan logic will proceed to ground the next column in sequence.

If a row is read as logic low while a column is grounded, the scan logic will implement a debounce delay of `DELAY.DEBDLY` clocks. If any rows are still grounded at the end of the debounce delay, a stabilization delay of `DELAY.STABDLY` clocks will then be implemented.

If the row readings between the start and end of the stabilization delay match, the scan logic determines that a key has been pressed, the scanner halts, and the `IF.KEY` interrupt flag is set. The details of which column is tested are reported in `STATUS.COL`, and the reading from all rows is stored in `STATUS.ROW`. The state machine will continue once `IF.KEY` is cleared.

For single-press scanning (`CFG.SINGLEPRESS` set to `SINGLEPRESS`), the next step in the scan sequence is to wait until all keys are unpressed. The state machine grounds all columns and waits until all rows read back '1'. When all keys are detected as unpressed, the scan logic will then continue scanning with the next column in sequence.

For multi-press scanning (`CFG.SINGLEPRESS` set to `MULTIPRESS`), scanning will proceed with the next column immediately when the `IF.KEY` interrupt is cleared. In multi-press mode, the `IF.NOKEY` interrupt flag will set once after a full scan cycle is completed without detecting a new key press, to indicate that all keys have been released and allow for subsequent press detections. Scans without a key press will not set this flag again until one or more new key presses have been detected.

Finally, the `IF.SCANNED` interrupt flag is set every time the scan logic completes an entire column-by-column scan without detecting any key presses.

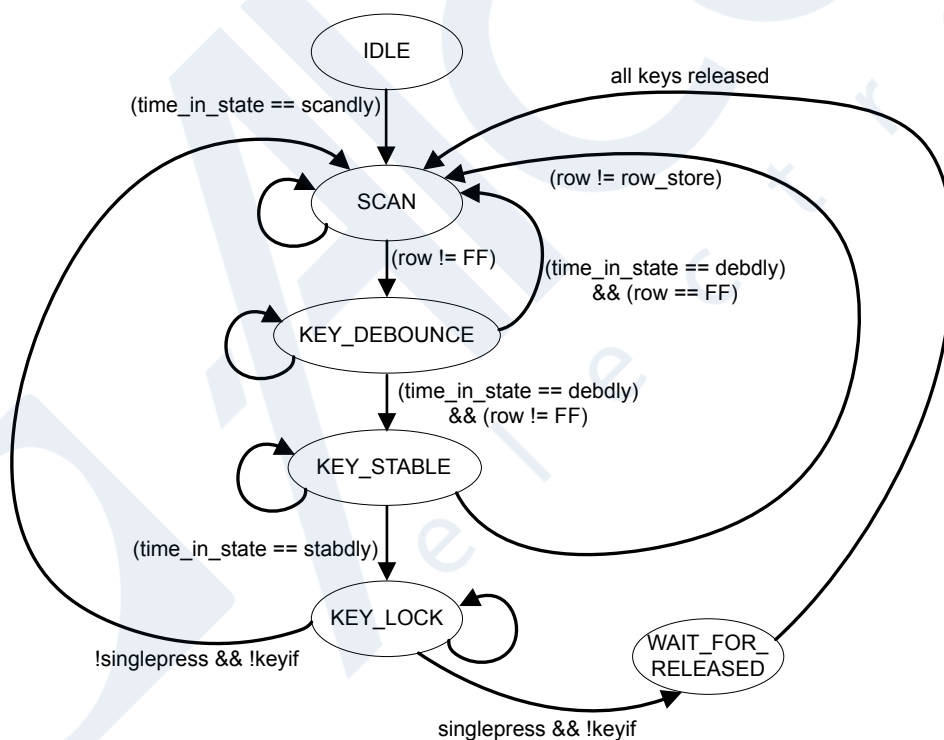

Figure 30.2. KEYSCAN State Machine

Figure 30.3 [Single Press Mode on page 1130](#) shows how the scanner operates in single-press mode. One interrupt is generated upon key press. The usage model is for a single key press at a time. If multiple keys are pressed at the same time, it stops scanning at the first column that has a key press and shows all the pressed rows for that column. Scanning does not resume until all pressed keys are released.

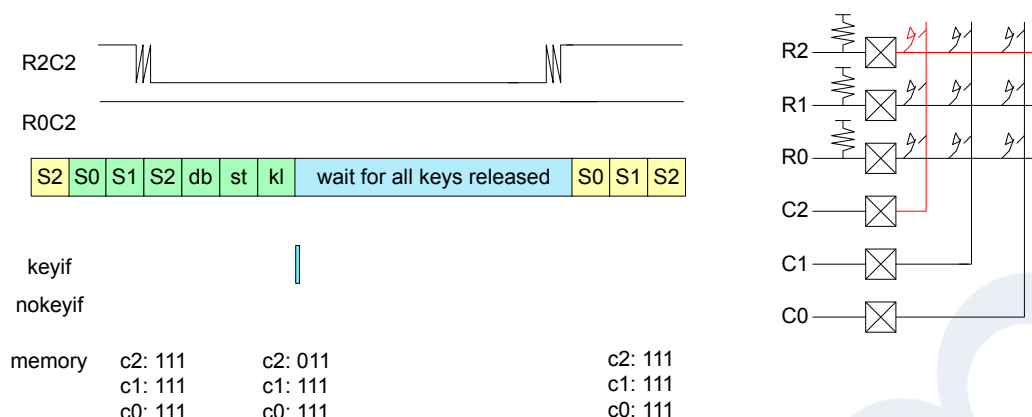

Figure 30.3. Single Press Mode

Figure 30.4 Multi-touch Mode with Multiple Key Presses on page 1130 shows two key presses that occur on the same column (R2C2 and R0C2). The first key press R2C2 was detected first and set the IF.KEY interrupt flag. The interrupt service routine read the status, updated an array in memory, and cleared the IF.KEY. Then the scanning continued until the IF.KEY was set again. Since both pressed keys are active on the same column, STATUS.ROW shows 010 for the low true key presses on R2C2 and R0C2. When both keys have been released and the scan cycles through without detecting any key presses, the IF.NOKEY flag is set.

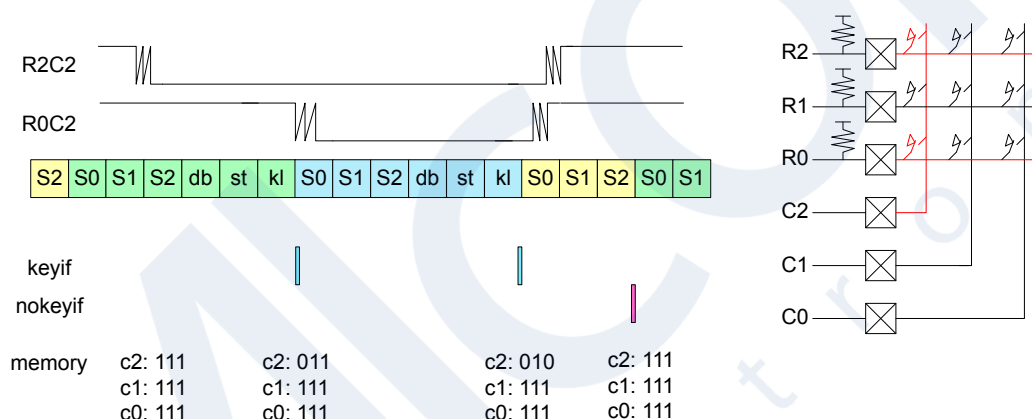

Figure 30.4. Multi-touch Mode with Multiple Key Presses

30.3.4 Wake on Key

The KEYSCAN module does not actively scan channels during EM2 or EM3, but it will operate in a wake-on-key mode when the IEN.WAKEUP interrupt is enabled. In this mode, all columns are driven low, and the logic waits for any of the row inputs to be pulled low. This event can wake the device from EM2 or EM3.

After waking up, the IF.WAKEUP flag will be set. Software may service this wakeup interrupt and start a new scan using the CMD.START command. Alternatively, if CMD.AUTOSTART has been used prior to sleeping, the keyscan will automatically be started each time the chip wakes up to EM0. Before going to sleep, software may use CMD.KEYSCANSTOP to turn off scanning if desired. If KEYSCANSTOP is not used, the keyscan module will still power down and stop scanning once the chip enters sleep. While most of the keyscan is powered down during EM2 and EM3, there is a small piece of logic that remains powered during EM2 and EM3 to allow a key press to wake the device.

A key press during sleep is unqualified, because no debouncing and settling are performed before waking the device. It is possible that noise in the mechanical keypad caused the wakeup without a real key press. In this case, after wakeup and scanning all columns, the IF.SCANNED interrupt comes in handy. IF.SCANNED would be set without IF.KEY or IF.NOKEY interrupts ever having been set. The IF.WAKEUP can be used to record to memory that the keypad has not yet completed any scans. Once IF.SCANNED fires without having seen any IF.KEY interrupts, this may indicate that the wakeup was due to noise instead of a key press, and the system can return to sleep.

30.4 KEYSKAN Register Map

The offset register address is relative to the registers base address.

Offset	Name	Type	Description
0x000	KEYSCAN_IPVERSION	R	IPVERSION
0x004	KEYSCAN_EN	RW ENABLE	Enable
0x008	KEYSCAN_SWRST	RW SWRST	Software Reset
0x00C	KEYSCAN_CFG	RW CONFIG	Config
0x010	KEYSCAN_CMD	W SYNC	Command
0x014	KEYSCAN_DELAY	RW CONFIG	Delay
0x018	KEYSCAN_STATUS	RH	Status
0x01C	KEYSCAN_IF	RWH INTFLAG	Interrupt Flags
0x020	KEYSCAN_IEN	RW	Interrupt Enables
0x1000	KEYSCAN_IPVERSION_SET	R	IPVERSION
0x1004	KEYSCAN_EN_SET	RW ENABLE	Enable
0x1008	KEYSCAN_SWRST_SET	RW SWRST	Software Reset
0x100C	KEYSCAN_CFG_SET	RW CONFIG	Config
0x1010	KEYSCAN_CMD_SET	W SYNC	Command
0x1014	KEYSCAN_DELAY_SET	RW CONFIG	Delay
0x1018	KEYSCAN_STATUS_SET	RH	Status
0x101C	KEYSCAN_IF_SET	RWH INTFLAG	Interrupt Flags
0x1020	KEYSCAN_IEN_SET	RW	Interrupt Enables
0x2000	KEYSCAN_IPVERSION_CLR	R	IPVERSION
0x2004	KEYSCAN_EN_CLR	RW ENABLE	Enable
0x2008	KEYSCAN_SWRST_CLR	RW SWRST	Software Reset
0x200C	KEYSCAN_CFG_CLR	RW CONFIG	Config
0x2010	KEYSCAN_CMD_CLR	W SYNC	Command
0x2014	KEYSCAN_DELAY_CLR	RW CONFIG	Delay
0x2018	KEYSCAN_STATUS_CLR	RH	Status
0x201C	KEYSCAN_IF_CLR	RWH INTFLAG	Interrupt Flags
0x2020	KEYSCAN_IEN_CLR	RW	Interrupt Enables
0x3000	KEYSCAN_IPVERSION_TGL	R	IPVERSION
0x3004	KEYSCAN_EN_TGL	RW ENABLE	Enable
0x3008	KEYSCAN_SWRST_TGL	RW SWRST	Software Reset
0x300C	KEYSCAN_CFG_TGL	RW CONFIG	Config
0x3010	KEYSCAN_CMD_TGL	W SYNC	Command
0x3014	KEYSCAN_DELAY_TGL	RW CONFIG	Delay
0x3018	KEYSCAN_STATUS_TGL	RH	Status
0x301C	KEYSCAN_IF_TGL	RWH INTFLAG	Interrupt Flags

Offset	Name	Type	Description
0x3020	KEYSCAN_IEN_TGL	RW	Interrupt Enables

30.5 KEYSKAN Register Description

30.5.1 KEYSKAN_IPVERSION - IPVERSION

Offset	Bit Position																															
0x000	31	30	29	28	27	26	25	24	23	22	21	20	19	18	17	16	15	14	13	12	11	10	9	8	7	6	5	4	3	2	1	0
Reset	0x1																															
Access	R																															
Name	IPVERSION																															

Bit	Name	Reset	Access	Description
31:0	IPVERSION	0x1	R	IPVERSION

30.5.2 KEYSKAN_EN - Enable

Offset	Bit Position																															
0x004	31	30	29	28	27	26	25	24	23	22	21	20	19	18	17	16	15	14	13	12	11	10	9	8	7	6	5	4	3	2	1	0
Reset																															0x0	0x0
Access																															R	RW
Name																															DISABLING	EN

Bit	Name	Reset	Access	Description
31:2	Reserved	<i>To ensure compatibility with future devices, always write Reserved bits to their reset value, unless otherwise stated. More information in 1.2 Conventions</i>		
1	DISABLING	0x0	R	Disablement busy status When EN is cleared, DISABLING status is set immediately, and cleared when disablement finishes. Disablement resets peripheral cores and bit fields or registers dependent on hardware state, such as INTFLAGS and FIFOs.
0	EN	0x0	RW	Enable
	Enable			
	Value	Mode		Description
	0	DISABLE		Stops clocking and resets peripheral core logic.
	1	ENABLE		Enables clocking, and begins scanning if CFG.AUTOSTART is 0x1.

30.5.3 KEYSCAN_SWRST - Software Reset

Offset	Bit Position																															
0x008	31	30	29	28	27	26	25	24	23	22	21	20	19	18	17	16	15	14	13	12	11	10	9	8	7	6	5	4	3	2	1	0
Reset																											0x0	0x0				
Access																											R	W				
Name																											RESETTING	SWRST				

Bit	Name	Reset	Access	Description
31:2	<i>Reserved</i>	<i>To ensure compatibility with future devices, always write Reserved bits to their reset value, unless otherwise stated. More information in 1.2 Conventions</i>		
1	RESETTING Software reset busy status	0x0	R	Software reset busy status
0	SWRST Software reset command	0x0	W	Software reset command

30.5.4 KEYSKAN_CFG - Config

Offset	Bit Position																																			
0x00C	31	30	29	28	27	26	25	24	23	22	21	20	19	18	17	16	15	14	13	12	11	10	9	8	7	6	5	4	3	2	1	0				
Reset			0x2			0x5			0x0		0x0																									0x1387F
Access			RW			RW			RW		RW																									RW
Name			NUMCOLS			NUMROWS			AUTOSTART		SINGLEPRESS																									CLKDIV

Bit	Name	Reset	Access	Description
31	<i>Reserved</i>	<i>To ensure compatibility with future devices, always write Reserved bits to their reset value, unless otherwise stated. More information in 1.2 Conventions</i>		
30:28	NUMCOLS	0x2	RW	Number of Columns Number of Columns minus one (0x2 indicates 3 columns)
27	<i>Reserved</i>	<i>To ensure compatibility with future devices, always write Reserved bits to their reset value, unless otherwise stated. More information in 1.2 Conventions</i>		
26:24	NUMROWS	0x5	RW	Number of Rows Number of Rows minus 1(5: represents 6 rows)
	Value	Mode		Description
	0	RSV1		1 Row is not supported; defaults to 3 instead
	1	RSV2		2 Rows are not supported; defaults to 3 instead
	2	ROW3		3 Rows
	3	ROW4		4 Rows
	4	ROW5		5 Rows
	5	ROW6		6 Rows
23	<i>Reserved</i>	<i>To ensure compatibility with future devices, always write Reserved bits to their reset value, unless otherwise stated. More information in 1.2 Conventions</i>		
22	AUTOSTART	0x0	RW	Automatically Start Automatically start when EN is set to 0x1.
	Value	Mode		Description
	0	AUTOSTARTDIS		Auto start is disabled
	1	AUTOSTARTEN		Auto start is enabled
21	<i>Reserved</i>	<i>To ensure compatibility with future devices, always write Reserved bits to their reset value, unless otherwise stated. More information in 1.2 Conventions</i>		
20	SINGLEPRESS	0x0	RW	Single Press

Generates one interrupt per keypress. Then waits for all keys to be released and IF.KEYIF=0x0 before it starts scanning again. When singlepress is not set, scanning continues once IF.KEYIF=0x0 which allows for multi-touch detection.

Bit	Name	Reset	Access	Description
	Value	Mode		Description
0		MULTIPRESS		After KEYIF is set and then cleared, scanning will continue. This can give multiple interrupts for the same key press, but allow multiple key presses to be detected. To use this mode for multi-key detection, the ISR should update a section of memory of COLNUM bytes on each interrupt, until key release is detected. After key release, the section of memory where key presses are recorded can be processed.
1		SINGLEPRESS		After KEYIF has been set and cleared, it will not set again until no key press is detected. This allows faster response since the ISR can start processing data as soon as the KEYIF is set.
19:18	<i>Reserved</i>	<i>To ensure compatibility with future devices, always write Reserved bits to their reset value, unless otherwise stated. More information in 1.2 Conventions</i>		
17:0	CLKDIV	0x1387F	RW	Clock Divider Divides the peripheral clock by (CLKDIV+1) to produce a timebase for the keyscan timers. The nominal target timebase is 2 ms.

30.5.5 KEYSKAN_CMD - Command

Offset	Bit Position																															
0x010	31	30	29	28	27	26	25	24	23	22	21	20	19	18	17	16	15	14	13	12	11	10	9	8	7	6	5	4	3	2	1	0
Reset																													0x0	0x0		
Access																													W(nB)	W(nB)		
Name																													KEYSCANSTOP	KEYSCANSTART		

Bit	Name	Reset	Access	Description
31:2	<i>Reserved</i>	<i>To ensure compatibility with future devices, always write Reserved bits to their reset value, unless otherwise stated. More information in 1.2 Conventions</i>		
1	KEYSCANSTOP Stop Keyscan	0x0	W(nB)	Keyscan Stop
0	KEYSCANSTART Start Keyscan	0x0	W(nB)	Keyscan Start

30.5.6 KEYSCAN_DELAY - Delay

Offset	Bit Position																															
0x014	31	30	29	28	27	26	25	24	23	22	21	20	19	18	17	16	15	14	13	12	11	10	9	8	7	6	5	4	3	2	1	0
Reset					0x0								0x0								0x0											
Access					RW								RW								RW											
Name					STABDLY								DEBDLY								SCANDLY											

Bit	Name	Reset	Access	Description
31:28	<i>Reserved</i>	<i>To ensure compatibility with future devices, always write Reserved bits to their reset value, unless otherwise stated. More information in 1.2 Conventions</i>		
27:24	STABDLY	0x0	RW	Row stable Delay
	Row stable delay			
	Value	Mode	Description	
	0	STABDLY2	2ms Row Stable Delay	
	1	STABDLY4	4ms Row Stable Delay	
	2	STABDLY6	6ms Row Stable Delay	
	3	STABDLY8	8ms Row Stable Delay	
	4	STABDLY10	10ms Row Stable Delay	
	5	STABDLY12	12ms Row Stable Delay	
	6	STABDLY14	14ms Row Stable Delay	
	7	STABDLY16	16ms Row Stable Delay	
	8	STABDLY18	18ms Row Stable Delay	
	9	STABDLY20	20ms Row Stable Delay	
	10	STABDLY22	22ms Row Stable Delay	
	11	STABDLY24	24ms Row Stable Delay	
	12	STABDLY26	26ms Row Stable Delay	
	13	STABDLY28	28ms Row Stable Delay	
	14	STABDLY30	30ms Row Stable Delay	
	15	STABDLY32	32ms Row Stable Delay	
23:20	<i>Reserved</i>	<i>To ensure compatibility with future devices, always write Reserved bits to their reset value, unless otherwise stated. More information in 1.2 Conventions</i>		
19:16	DEBDLY	0x0	RW	Debounce Delay
	Debounce Delay			
	Value	Mode	Description	
	0	DEBDLY2	2ms Debounce Delay	
	1	DEBDLY4	4ms Debounce Delay	

Bit	Name	Reset	Access	Description
2		DEBDLY6		6ms Debounce Delay
3		DEBDLY8		8ms Debounce Delay
4		DEBDLY10		10ms Debounce Delay
5		DEBDLY12		12ms Debounce Delay
6		DEBDLY14		14ms Debounce Delay
7		DEBDLY16		16ms Debounce Delay
8		DEBDLY18		18ms Debounce Delay
9		DEBDLY20		20ms Debounce Delay
10		DEBDLY22		22ms Debounce Delay
11		DEBDLY24		24ms Debounce Delay
12		DEBDLY26		26ms Debounce Delay
13		DEBDLY28		28ms Debounce Delay
14		DEBDLY30		30ms Debounce Delay
15		DEBDLY32		32ms Debounce Delay
15:12	<i>Reserved</i>	<i>To ensure compatibility with future devices, always write Reserved bits to their reset value, unless otherwise stated. More information in 1.2 Conventions</i>		
11:8	SCANDLY Scan Delay	0x0	RW	Scan Delay
	Value	Mode	Description	
	0	SCANDLY2	2ms Scan Delay	
	1	SCANDLY4	4ms Scan Delay	
	2	SCANDLY6	6ms Scan Delay	
	3	SCANDLY8	8ms Scan Delay	
	4	SCANDLY10	10ms Scan Delay	
	5	SCANDLY12	12ms Scan Delay	
	6	SCANDLY14	14ms Scan Delay	
	7	SCANDLY16	16ms Scan Delay	
	8	SCANDLY18	18ms Scan Delay	
	9	SCANDLY20	20ms Scan Delay	
	10	SCANDLY22	22ms Scan Delay	
	11	SCANDLY24	24ms Scan Delay	
	12	SCANDLY26	26ms Scan Delay	
	13	SCANDLY28	28ms Scan Delay	
	14	SCANDLY30	30ms Scan Delay	
	15	SCANDLY32	32ms Scan Delay	
7:0	<i>Reserved</i>	<i>To ensure compatibility with future devices, always write Reserved bits to their reset value, unless otherwise stated. More information in 1.2 Conventions</i>		

30.5.7 KEYSKAN_STATUS - Status

Offset	Bit Position																															
0x018	31	30	29	28	27	26	25	24	23	22	21	20	19	18	17	16	15	14	13	12	11	10	9	8	7	6	5	4	3	2	1	0
Reset	0x0	0x1				0x0										0x0															0x0	
Access	R	R				R										R															R	
Name	SYNCBUSY	NOKEY				COL									RUNNING															ROW		

Bit	Name	Reset	Access	Description
31	SYNCBUSY Sync Busy	0x0	R	Sync Busy
30	NOKEY No Key pressed status	0x1	R	No Key pressed status
29:27	<i>Reserved</i>	<i>To ensure compatibility with future devices, always write Reserved bits to their reset value, unless otherwise stated. More information in 1.2 Conventions</i>		
26:24	COL column that corresponds to key press	0x0	R	Column Latched
23:17	<i>Reserved</i>	<i>To ensure compatibility with future devices, always write Reserved bits to their reset value, unless otherwise stated. More information in 1.2 Conventions</i>		
16	RUNNING Running	0x0	R	Running
15:6	<i>Reserved</i>	<i>To ensure compatibility with future devices, always write Reserved bits to their reset value, unless otherwise stated. More information in 1.2 Conventions</i>		
5:0	ROW Rows (1: pull up for no key press, 0: key press)	0x0	R	Row detection

30.5.8 KEYSKAN_IF - Interrupt Flags

Offset	Bit Position																																		
	31	30	29	28	27	26	25	24	23	22	21	20	19	18	17	16	15	14	13	12	11	10	9	8	7	6	5	4	3	2	1	0			
0x01C																																			
Reset																											0x0	0x0	0x0	0x0					
Access																											RW	RW	RW	RW					
Name																											WAKEUP	SCANNED	KEY	NOKEY					

Bit	Name	Reset	Access	Description
31:4	<i>Reserved</i>	<i>To ensure compatibility with future devices, always write Reserved bits to their reset value, unless otherwise stated. More information in 1.2 Conventions</i>		
3	WAKEUP	0x0	RW	<p>Wake up</p> <p>During sleep all columns are grounded and any keypress on any row will cause a wakeup and set WAKEUP. During EM01 WAKEUP will not get set.</p>
2	SCANNED	0x0	RW	<p>Completed scan</p> <p>SCANNED sets each time all columns are scanned and no keypress is detected. The start of the scan is either from column 0 (after reset), or from the column of the last keypress.</p>
1	KEY	0x0	RW	<p>A key was pressed</p> <p>A key was pressed (This stops scan until the interrupt flag is cleared)</p>
0	NOKEY	0x0	RW	<p>No key was pressed</p> <p>After a keypress is detected and IF.KEY interrupt cleared, NOKEY will set one time, after all the columns have been checked without detecting a keypress.</p>

30.5.9 KEYSKAN_IEN - Interrupt Enables

Offset	Bit Position																															
0x020	31	30	29	28	27	26	25	24	23	22	21	20	19	18	17	16	15	14	13	12	11	10	9	8	7	6	5	4	3	2	1	0
Reset																										0x0	0x0	0x0	0x0			
Access																										RW	RW	RW	RW			
Name																										WAKEUP	SCANNED	KEY	NOKEY			

Bit	Name	Reset	Access	Description
31:4	Reserved			To ensure compatibility with future devices, always write Reserved bits to their reset value, unless otherwise stated. More information in 1.2 Conventions
3	WAKEUP	0x0	RW	Wake up A key press was detected during the first complete scan. This could be either after wake up from sleep or during the first complete scan after the first time the KEYSKAN module was enabled.
2	SCANNED	0x0	RW	Completed Scanning SCANNEDIF sets each time all columns are scanned and no keypress is detected. The start of the scan is either from column 0 (after reset), or from the column of the last keypress.
1	KEY	0x0	RW	A Key was pressed A Key was pressed (This stops scan until the interrupt flag is cleared)
0	NOKEY	0x0	RW	No Key was pressed After keypress is detected and keyif interrupt cleared, the NOKEYIF will set one time once all the columns are checked with no keypress.

31. MVP - Matrix Vector Processor

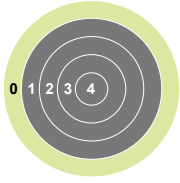

Quick Facts

What?

The Matrix Vector Processor accelerates floating point operations, particularly matrixed complex floating point multiplications and additions

Why?

The Matrix Vector Processor hardware can save energy by offloading heavily floating-point computational intensive operations, including the Angle-of-Arrival (AoA) MUSIC algorithm, Machine Learning (ML) and linear algebra

How?

The Matrix Vector Processor includes a dedicated hardware arithmetic logic unit (ALU), load/store unit (LSU), and sequencer.

31.1 Introduction

The Matrix Vector Processor (MVP) is designed to offload the major computationally intensive floating point operations, particularly matrixed complex floating point multiplications and additions. The MVP hardware supports the acceleration of the key Angle-of-Arrival (AoA) MUSIC (MUltiple Signal Classification) algorithm computations, as well as other heavily floating-point computational problems such as Machine Learning (ML) or linear algebra.

31.2 Features

- Instruction Set Architecture (ISA)
 - General purpose instruction set tailored towards algorithms built out of ALU, loop, and load/store instructions
 - Enables many high-level array functions, e.g.:
 - Matrix multiplication
 - Element-wise matrix multiplication
 - Matrix addition
 - Power series generation
 - Convolution
 - Program flexibility allows efficient iteration over N-dimensional array elements, including in-place processing of special matrix views:
 - Element-wise negate / conjugate
 - Transpose / adjoint / reverse
 - Matrix blocks (i.e., rectangular parts of matrix)
 - Matrix slices (i.e., taking rows, columns, or elements uniformly spaced within a matrix)
 - Row-major or column-major ordering
- Arithmetic Logic Unit (ALU)
 - Three 32-bit floating-point input operands, interpreted as real or complex numbers
 - Partial integer input support
 - One 32-bit floating-point output operands, interpreted as real or complex numbers
 - Register bank to hold all input/output operands
 - Includes 8 registers for temporary storage and/or accumulation
 - Hardware to support 1 complex floating point multiply-accumulate (MAC) per cycle
 - Four single-precision floating-point multipliers
 - Four single-precision floating-point adders
 - 6x performance of Cortex M33 FMAC operations
 - Operations supported at a rate of one operation per cycle:
 - Complex addition, multiplication, and MAC operations
 - Parallel real multiplication and MAC
 - Parallel real addition
 - Sum of 4 reals
 - Squared-magnitude of complex/real
 - Integer-to-float conversion
 - Conditional computation
 - Input transformations (per real/complex part of each input)
 - Negation (complex conjugate)
 - Zero-masking (real/imaginary part decomposition)
- Load/Store Unit (LSU)
 - Controls data streaming from memory-to-ALU and vice versa
 - Pipelined architecture to support two simultaneous 32-bit memory reads and one 32-bit memory write per cycle
 - Supports signed / unsigned 8-bit integer conversion for both load and store operations
 - First-party DMA ports
 - Used by load / store unit for handling accesses to external (system) memory addresses
 - Three independent 32-bit AHB manager ports for supporting 2 read channels and 1 write channel simultaneously
- Sequencer
 - Coordinates all MVP blocks to execute a sequence of instructions provided via the programming interface
 - Handles array iteration according to instruction sequence and static array configuration
 - Handles loop iteration according to instruction sequence and static loop configuration

- Programming interface
 - Control registers for starting / stopping engine
 - Status registers about ongoing and finished instruction sequences
 - Fault status
 - Useful information for debug
 - Breakpoint and stepping controls for debug
 - Interrupts and faults
 - Instruction sequence completion
 - Bus faults
 - Loop faults
 - Array faults
 - Array configuration registers
 - Loop configuration registers
 - Instruction queue registers
 - Array iteration
 - ALU operations
 - Looping

31.3 Functional Description

The Matrix Vector Processor (MVP) is a peripheral processor that can be used to accelerate the processing of floating point operations while offloading the primary CPU. At a high level, it consists of:

- A register interface for programming and controlling operations
- A sequencer (which includes the loop controllers) that manages execution of the program
- Array and bus controllers that manage addressing, loading, and storing of data in arrays stored in system memory
- The pipeline controller, ALU, and ALU register bank for processing data

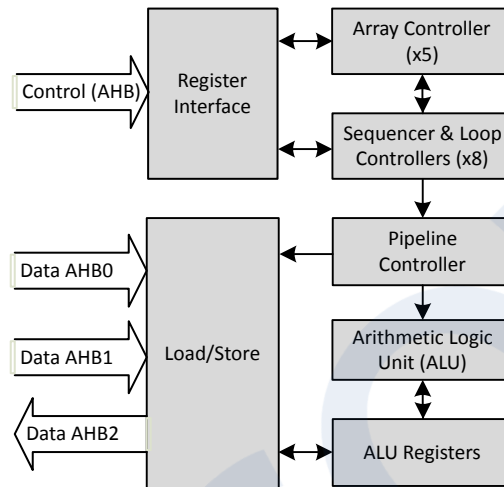

Figure 31.1. MVP Block Diagram

For most operations, software will program the MVP to address matrix (array) data in system memory and then process this data to perform a useful computation. The MVP provides three primary resources for controlling the operations that are fed through the ALU:

- Eight instructions, each of which encodes an ALU operation, load/store controls for the cycle, array increment controls, and loop controls
- Eight loop controllers, which can be used to form loops around a single or multiple instructions and can be nested to form complex sequences of ALU operations
- Five array controllers, each of which configure and control access to an independent matrix of data in system memory. The MVP supports arrays of up to 3 dimensions and each dimension can be independently incremented by the load/store streams, instruction, or loop controller on any given cycle

All of the MVP's control registers reside within its own register space, including the eight instructions (each of which is three 32-bit words). The MVP's register space has been organized such that DMA can be used to program all the configuration registers sequentially and initiate an operation with minimal CPU intervention. Once the program has successfully completed (by reaching an instruction with ENDPROG while completing all outstanding loops), the MVP interrupts the CPU with the PROGDONE interrupt. In the case of a fatal error (usually misprogramming), the MVP issues an error interrupt and terminate processing immediately.

32. Revision History

Revision 1.1

January, 2024

- [4.2.4.1 Peripheral Map](#): Removed non-essential entries
- [4.2.2 Flash](#): Removed flash erase cycle and data retention endurance. Flash characteristics are provided in device datasheet and data retention information is published in Quarterly Quality and Reliability Report.
- [6.3.5 Bootloader](#): Updated user guide reference from UG266 to UG489.
- [6.3.12 Erase and Write Operations](#): Removed flash write and erase operations clock source and configuration information. These settings should not be modified from default.
- [6.6.5 SYSCFG Register Map](#): Updated SYSCFG_CHIPRELVHW.FAMILY reset value and added SYSCFG_CHIPREV.CHIP values and register bit descriptions.
- [6.8.8 MSC_STATUS - Status Register](#): Fixed TIMEOUT, PENDING, and ERASEABORTED bit descriptions.
- [6.6.7 MPAHBRAM Register Map](#): Removed internal configuration registers from map.
- [Figure 8.2 High Frequency Peripheral Clocks on page 150](#): Added KEYSKAN peripheral in EM01GRPACLK branch.
- [9.4.3.2 Lock Modes](#): Updated language regarding DPLL phase lock mode.
- [12.7.5 DCDC_PFMXCTRL - PFMX Control Register](#): Added IPKVAL enumerations and descriptions for 90 mA through 120 mA Ipeak.
- [23. IADC - Incremental Analog to Digital Converter](#): Updated chapter content to include high-speed and high-accuracy mode information
- [24. GPIO - General Purpose Input/Output](#): Updated GPIO_IF clear and set register references throughout chapter to match register naming convention.
- [LDMA](#)
 - [25.3.7.2 SYNC Descriptor Structure](#): Added missing fields in SRC and DST words.
 - [25.3.7.3 WRI Descriptor Structure](#): Added missing field in SRC word.
 - Clarifications and corrections to LDMA_IPVERSION, LDMA_CHDONE, LDMA_CHDIS, and LDMA_CHx_LINK bitfield descriptions
- [29. ACMP - Analog Comparator](#): Deprecated capacitive sensing. Removed capacitive sense mode chapter, removed register description mentions of capacitive sensing, and removed other references of capacitive sensing throughout document. This feature is not recommended for new designs.
- [30. KEYSKAN - Keyboard Scan](#): Updated row configuration description to add clarification regarding available ports.

Revision 1.0

May, 2023

- FRONT PAGE: Updated Front Page block diagram [EFR32xG24 Wireless SoC](#) to indicate that the LFRCO is available down to EM4
- SYSTEM OVERVIEW: Corrected memory map diagram and text in [4.2 Functional Description](#)
- SE: Added Secure Element chapter [11. SE - Secure Engine Subsystem](#)
- EMU: General improvements and clarifications in [Table 12.2 Energy Modes on page 291](#) table
- EMU: Added BURAM to Power Domains table in [Table 12.4 Peripheral Power Subdomains on page 298](#)
- EMU: Added EMU.TAMPERRSTCAUSE register and removed EMU.SEQIF and EMU.SEQIEN registers in [12.5 EMU Register Description](#)
- EMU: Added EMU.CMD.TAMPERRCLR bit to [12.5.10 EMU_CMD - EMU Command Register](#)
- EMU: Added EMU.RSTCAUSE.SETAMPER bit to [12.5.16 EMU_RSTCAUSE - Reset Cause](#)
- DCDC: Corrected Buck Mode Recommended Settings for EM23CTRL0.DRVSPD and CTRL.IPKTMAXCTRL in [12.3.8.3 Buck DC-DC Recommended Configuration Settings](#)
- DCDC: Corrected EM23CTRL0.IPKVAL enums in [12.7.4 DCDC_EM23CTRL0 - EM23 Control](#)
- DCDC: Updated register enum descriptions for DRVSPD in [12.7.4 DCDC_EM23CTRL0 - EM23 Control](#) and [12.7.3 DCDC_EM01CTRL0 - EM01 Control](#) to clarify that only the default setting is recommended for use (no benefit to using other settings)
- DCDC: Corrected DCDC.PFXMCTRL.IPKVAL description equation in [12.7.5 DCDC_PFXMCTRL - PFMX Control Register](#)
- PRS: Corrected number of asynchronous PRS channels from 12 to 16 in [13. PRS - Peripheral Reflex System](#)
- EUSART: Updates to [EUSART](#) chapter to clarify operation differences when running from a low-frequency vs high-frequency clock source on EUSART0.
- GPIO: Added GPIO.RAC_ROUTEEN, GPIO.RAC_LNAENROUTE, and GPIO.RAC_PAENROUTE registers to [24. GPIO - General Purpose Input/Output](#)
- LDMA: Corrected [25.7.28 LDMA_CHx_LINK - Channel Descriptor Link Address](#) description to add a "NOT". Correct description reads: "After completing the initial transfer, if this bit is NOT set, the DMA will load the next linked descriptor. If the next linked descriptor also has this bit set, the DMA will load the next linked descriptor."
- VDAC: Updates to [28.3.17 Sine Generation Mode](#) section
- ACMP: Added note about additional warm-up time required when BIAS<=3 to [29.3.2 Warmup Time](#)
- MVP: Removed Registers and Definitions from MVP section - use of the MVP shouldn't require access to these registers

Revision 0.5

April, 2022

- Updated System Block Diagrams
- Many register bits access descriptions updated to add (nB) or (r) designators
- Acronym clarifications in [5. Radio Transceiver](#) section
- [System](#) Chapter:
 - Added M33CTI0/1 to Interrupt Request Lines table
- [6. MSC - Memory System Controller](#) Chapter:
 - Renamed MSC_PAGELOCKWORDx registers to MSC_PAGELOCKx
 - Added Write/Erase via "debug" for Information block in [Table 6.1 MSC Flash Memory Mapping on page 56](#)
- Removed Debug Chapter registers
- [8. CMU - Clock Management Unit](#) Chapter:
 - Updated clock tree showing EM01GRPACLK vs EM01GRPACLKRT
 - Corrected max PCLK and RHCLK frequencies from 50MHz to 40MHz throughout chapter
 - Clarifications on naming of EXPORTCLK throughout chapter and register descriptions
 - Clarifications to and [8.3.5 Clock Output](#) sections
 - Added HFRCODPLLRT and HFXORT enums to EM01GRPxCLKCTRL.CLKSEL bitfields
- [9. Oscillators](#) Chapter:
 - Corrected typical HF XO crystal frequency from 38.4 to 39 MHz
 - Improvements to [9.6.3.4.1 Reference Frequency](#) section
 - Added EM23ONDEMAND bit to HFRCO_CTRL register
 - Added HFRCOEM23 to HFRCO features
 - Updated text to clarify that ULFRCO is available in EM4 in [9.8 ULFRCO - Ultra Low Frequency RC Oscillator](#)
- [12. EMU - Energy Management Unit](#) Chapter:
 - Clarified that EM1P only supports RX radio usage (not TX)
 - Removed PPMODE bit from the DCDC_STATUS, DCDC_IEN, DCDC_IF registers
 - Corrections to section
 - Improvements to the Power Domains section
 - Added IADC, ACMP, and VDAC to the Low Energy Wakeup Triggers
 - Updated Temperature Sensor Polynomial Coefficients
- [13. PRS - Peripheral Reflex System](#) Chapter:
 - Clarified modules using synchronous channels
 - Added CORE CTIOUTx signals to [13.3.3 Producers](#) table
 - Corrections to [Table 13.3 List of Logic Functions on page 348](#)
- [20. USART - Universal Synchronous Asynchronous Receiver/Transmitter](#) Chapter: Inclusive language updates
- [21. EUSART - Universal Synchronous Asynchronous Receiver/Transmitter](#) Chapter:
 - Added CSWU bit to EUSART_IEN and EUSART_IF registers
 - Added IRLFCFG register
 - Added RXDMAWU and TXDMAWU bits to EUSART_CFG1 register
 - Inclusive language updates
- [22. I2C - Inter-Integrated Circuit Interface](#) Chapter:
 - Clarified DMA support
 - Inclusive language updates
- [23. IADC - Incremental Analog to Digital Converter](#) Chapter:
 - Removed VREF from odd / even mux inputs in Block Diagram and text
 - Removed SINGLEDATADV and SCANDATADV bits from IADC_STATUS
 - Added High Speed and High Accuracy register options in IADC_CFGx.ADCMODE
 - Added OSRHA bitfield in IADC_CFGx.ADCMODE
 - Added External VREF=2.5V option in IADC_CRFx.REFSEL

- [24. GPIO - General Purpose Input/Output](#) Chapter:
 - Renamed all "GPIO_TIMERx_CCCx" registers, bits, and signals to "GPIO_TIMERx_CDTIx"
 - Improvements in display of GPIO Alternate Function Table
 - Added note on SWV pin and debug lock in [24.3.9.2 Serial Wire Debug Connection](#)
 - Removed DCDC and RAC ROUTEEN registers
- Added additional notes on input frequency in [27.3.8 PRS and PCNTn_S0IN,PCNTn_S1IN Inputs](#)
- Clarified energy mode support in [26. WDOG - Watch Dog Timer](#) Chapter

Revision 0.2

October, 2021

- Removed references to non-applicable blocks

Revision 0.1

July, 2021

- Initial Release

Appendix 1. Abbreviations

This section lists abbreviations used in this document.

Table 1.1. Abbreviations

Abbreviation	Description
ADC	Analog to Digital Converter
AES	Advanced Encryption Standard
AFC	Automatic Frequency Control
AGC	Automatic Gain Control
AHB	AMBA Advanced High-performance Bus. AMBA is short for "Advanced Microcontroller Bus Architecture".
APB	AMBA Advanced Peripheral Bus. AMBA is short for "Advanced Microcontroller Bus Architecture".
APC	Automatic Power Control
ASK	Amplitude Shift Keying
BLE	Bluetooth Low Energy
BLE-LR	Bluetooth Low Energy Long Range
BR	Baud Rate
BT	Bandwidth Time product
BUFC	Buffer Controller
BW	Bandwidth
CBC	Cipher Block Chaining (AES mode of operation)
CBC-MAC	Cipher Block Chaining - Message Authentication Code (AES mode of operation)
CC	Compare / Capture
CCA	Clear Channel Assessment
CFB	Cipher Feedback (AES mode of operation)
CHF	Channel Filter
CLK	Clock
CM3	ARM Cortex-M3
CM4	ARM Cortex-M4
CMD	Command
CMU	Clock Management Unit
CRC	Cyclic Redundancy Check
CTR	Counter mode (AES mode of operation)
CTRL	Control
DBG	Debug
DC	Direct Current
DEC	Decimator
DEMOD	Demodulator

Abbreviation	Description
DSA	Detection of Signal Arrival
DSSS	Direct Sequence Spread Spectrum
ECB	Electronic Code Book (AES mode of operation)
EFM32	Energy Friendly Microcontroller
EFR32	Wireless Gecko
EM	Energy Mode
EMU	Energy Management Unit
FEC	Forward Error Correction
FIR	Finite Impulse Response
FRC	Frame Controller
FSK	Frequency Shift Keying
FSM	Finite State Machine
GFSK	Gaussian Frequency Shift Keying
GMSK	Gaussian Minimum Shift Keying
GPIO	General Purpose Input / Output
HFRCO	High Frequency RC Oscillator
HFXO	High Frequency Crystal Oscillator
HW	Hardware
Hz	Hertz
IF	Intermediate Frequency
IFADC	Intermediate Frequency Analog to Digital Converter
ISR	Interrupt Service Routine
LFRCO	Low Frequency RC Oscillator
LFXO	Low Frequency Crystal Oscillator
LNA	Low Noise Amplifier
LO	Local Oscillator
MOD	Modulator
MODEM	Modulator and Demodulator
MSK	Minimum Shift Keying
NRZ	Non Return to Zero
NVIC	Nested Vector Interrupt Controller
OFB	Output Feedback Mode (AES mode of operation)
OOK	On Off Keying
OQPSK	Offset Quadrature Phase Shift Keying
OSR	Over-Sampling Ratio
PA	Power Amplifier
PD	Power Down

Abbreviation	Description
PHY	Physical Layer
PROTIMER	Protocol Timer
PRS	Peripheral Reflex System
PWM	Pulse Width Modulation
RAC	Radio Controller
RAM	Random Access Memory
RF	Radio Frequency
RMU	Reset Management Unit
RSM	Radio State Machine
RSSI	Received Signal Strength Indicator
RTC	Real Time Counter
RX	Receive
SEQ	Radio Sequencer
SPI	Serial Peripheral Interface
SRC	Sample Rate Converter
STIMER	Sequencer Timer
SW	Software
SYNTH	Synthesizer
TX	Transmit
XTAL	Crystal