



Product image for illustration Purposes only

Introduction

The easyRadio eRIC-LoRa (Long Range) RF transceiver module uses Chirped Spread Spectrum (CSS) modulation together with DSP (Digital Signal Processing) to achieve greater range than traditional devices using OOK, FSK or GFSK modulation.

In addition, sensitivity and blocking performance are improved giving high interference immunity whilst still offering low power consumption.

The module is a complete sub-system that combines a high-performance low power RF transceiver, a microcontroller and a voltage regulator.

Key operating parameters can be changed and configured by sending simple 'text' (ASCII character) commands to the module.

Features

- Chirped Spread Spectrum Technology
- Pin compatible with eRIC series RF modules
- U.FL RF connector for remote antennas
- Multipoint communication
- Half duplex transparent Serial Data Input and Output
- Up to 180 bytes per packet
- Familiar easyRadio commands
- Built in temperature sensor
- 'Flash' firmware upgrades.
- New features and updates easily programmed using LPRS tools

Key Parameters

- Frequency Range: 860 – 1000MHz (Firmware dependant)
- Frequency Bands: EU/USA (Enquire for Rest of World)
- Receiver sensitivity: down to -137dBm
- Multi-channel operation
- RF Power output: up to +20dBm (100mW)
- Receive current consumption: 15mA
- RSSI dynamic range: 127dB
- Line of Sight (LoS) range – Up-to 10km+

User Programmable Options:

- Spreading factors 6 to 12
- Selectable Bandwidth: 125, 250, 500kHz
- Over air bit rates of up to 300 kbps offer effective 37.5 kbps data rate
- Host Data Rate: 2.4kbps – 115.2kbps
- The variable spreading factor in combination with bandwidth provide a balance between sensitivity (range) and data rate.

Applications

eRIC-LoRa is suitable for any device requiring long range low power operation. Popular in battery powered applications sensors and actuators high noise harsh environments, eRIC-LoRa provides a robust and reliable wireless engine for OEM's to take advantage of.

RAIL | SECURITY | FINANCE | ASSET TRACKING | INDUSTRIAL CONTROL | SENSORS | REMOTE MONITORING

AGRICULTURAL | DATA LOGGING | SMART HOME | INTERNET OF THINGS | MACHINE TO MACHINE |

INDUSTRIAL SENSING | ENERGY MONITORING | HVAC CONTROL AND MONITORING | FACILITIES MANAGEMENT

Table of Contents

1. eRIC-LoRa Transceiver overview	3
2. Pin/Pad Description	3
3. Mechanical & Production	4
3.1 PCB Layout Notes.....	4
3.2 Production - soldering & reflow	5
3.3 Conformal coating.....	5
3.4 eRA / eRIC Pin compatibility	6
4. Absolute Maximum Ratings.....	7
5. Logic Levels	8
6. Power Supply	8
7. Antennas.....	8
7.1 Antennas Approved for use with eRIC-LoRa.....	9
8. easyRadio eRIC/eRA Configuration Command Set.....	9
8.1 Reserved LoRa Group ID number assignments.....	12
8.2 Channel Frequencies.....	12
8.3 eRIC-LoRa Gateway Mode	12
9. Application & Operation of eRIC-LoRa Transceiver.....	13
9.1 SX1272 SPI Direct Mode.....	14
9.2 Transmission restrictions	14
9.3 eRIC-LoRa transmission guide	14
10. Product Order Code	14
10.1 Firmware.....	14
10.2 Programming Modules in Situ	15
10.3 MTBF.....	15
11. Regulatory Approvals	15
11.1 FCC Statement:	15
12. eRIC-LoRa Firmware Versions.....	15
13. Document History	15

1. eRIC-LoRa Transceiver overview

The easyRadio eRIC-LoRa RF transceiver module is a complete sub-system that combines a high performance low power RF transceiver, a microcontroller and a voltage regulator.

The Serial Data Input (SDI) and Serial Data Output (SDO) by default operate at the standard 19,200 Baud and two handshake lines provide optional flow control to and from the host. The easyRadio Transceiver can accept and transmit up to 180 bytes of data, which it buffers internally before transmitting in an efficient over-air code format.

Any other eRIC-LoRa transceiver, within range and on the same settings, that 'hears' the transmission will decode the message and place the recovered data within a receive buffer that can then be downloaded to the receiving host for processing and interpretation. Radio transmission and reception is bi-directional (half duplex) i.e. transmit OR receive but not simultaneously. Extra internal buffers however, allow the user to upload data while a download is in progress giving the appearance of fully duplex data flow.

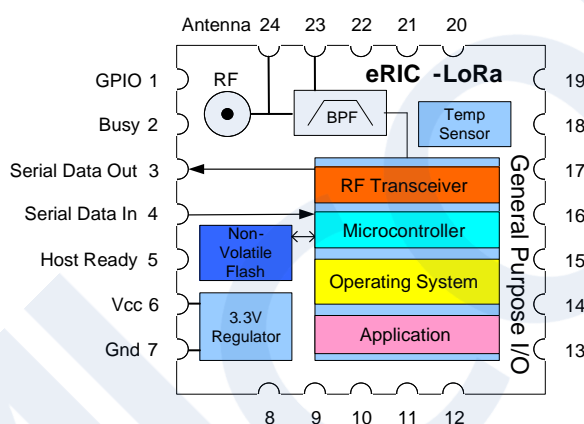

Figure 1 Block Diagram

2. Pin/Pad Description

Pad No	Name	Description	Notes
1	GPIO	General Purpose Digital I/O	Reserved for future use and customisation
2	Busy	Clear to Send (CTS) function Digital output	Indicates that transceiver is ready to receive serial data from the Host. Low – Transceiver Ready, High – Transceiver not Ready
3	SDO	Rx Serial Data Out (Default) Receive Data	Digital output - Connect to Host serial input
4	SDI	Tx Serial Data In (Default) Transmit Data	Digital input - Connect to Host serial output
5	Host Ready	Request to Send (RTS) function Digital input	Used to indicate that Host is ready to receive serial data from the Transceiver Low – Host Ready, High – Host Not Ready Wake up from Sleep Command (firmware dependant)
6	Vcc	Operating Supply Voltage	Internal 3.3V regulator operates from +2.4V to +6V Input.
7	Gnd	Power Ground	0V Ground
8 - 13	SX1272 IO 0 -5	SX1272 Digital IO Pins DIO-0 to DIO-5	Do not connect unless monitoring the SX1272 RFIC
14,15,16,18,19,20,21	Reserved		Reserved for future use and customisation
17	Sleep	Sleep Enable pin	Must be enabled in software: ER_CMD#a51 Set pin High to Sleep and set pin Low to re-enable the transceiver. From Firmware Version 4.1.16+
22	Reserved		VPP Programming Pin for PIC18F25K20 MCU
23	RF Gnd	RF Ground – 0V	Connect to antenna ground and local ground plane. Internally connected to Power Ground 0V
24	RF	50Ω RF Input/Output	Connect to suitable antenna via 50Ω PCB trace or use the alternative UFL connector

Notes

3.3V Regulator will continue to function (no regulation) below drop out voltage. Internal RF IC can operate down to 2.4V and still provide rated RF power output.

Pins/Pads 1-7 are physically (Pin/pad sequence) and electrically compatible with easyRadio eRA400/900 Transceivers. See drawing below.

3. Mechanical & Production

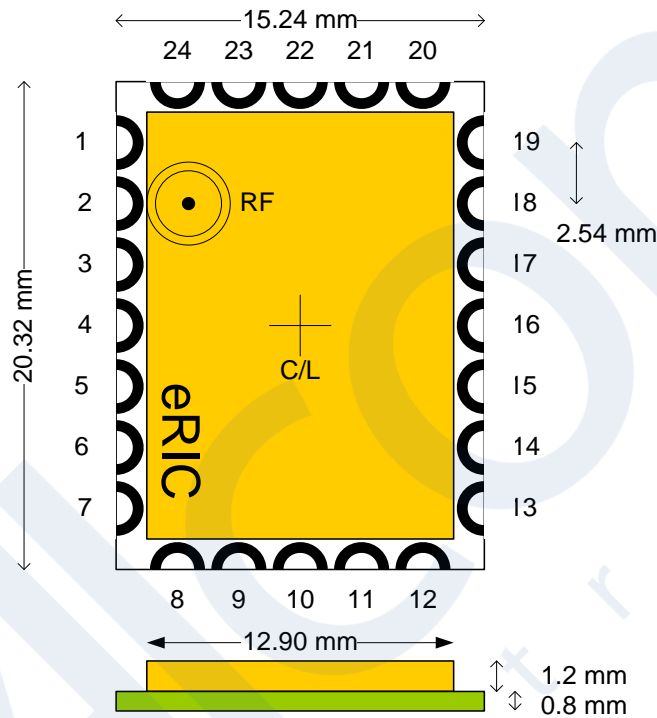

Figure 2 Mechanical Drawing

3.1 PCB Layout Notes

Pitch of the castellated connection pads is 2.54mm. Pads 4 & 16 and 10 & 22 are on centre line (C/L) of module

It is recommended that the module is mounted on a double-sided PCB and that the area below the module be flooded with additional copper ground plane if possible. This should be connected to pad 23 (RF Ground) and pad 7 (Power Ground).

The recommended pad layout is shown below. Pads should be solid with no hole.

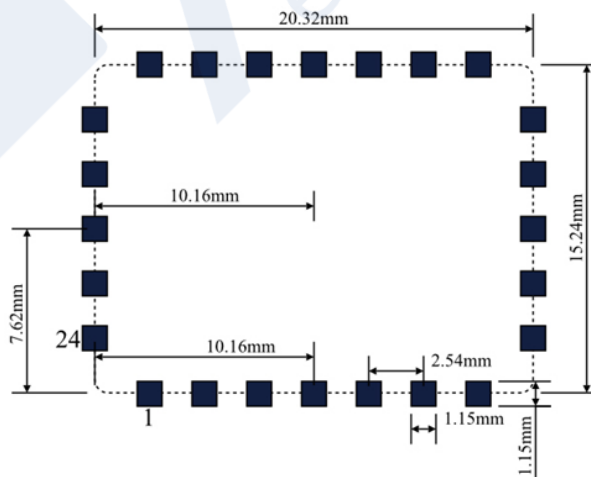

Figure 3 PCB Layout Dimensions

3.2 Production - soldering & reflow

eRIC modules have been designed for reflow soldering but should only be subjected to this process once. Multiple passes may cause permanent internal component damage and is therefore not recommended.

Should multiple reflows take place, the customer does so at their own risk and LPRS provides no warranty against damages caused to this module.

For optimum reflow of this module, please see below our recommended reflow soldering profile for this device.

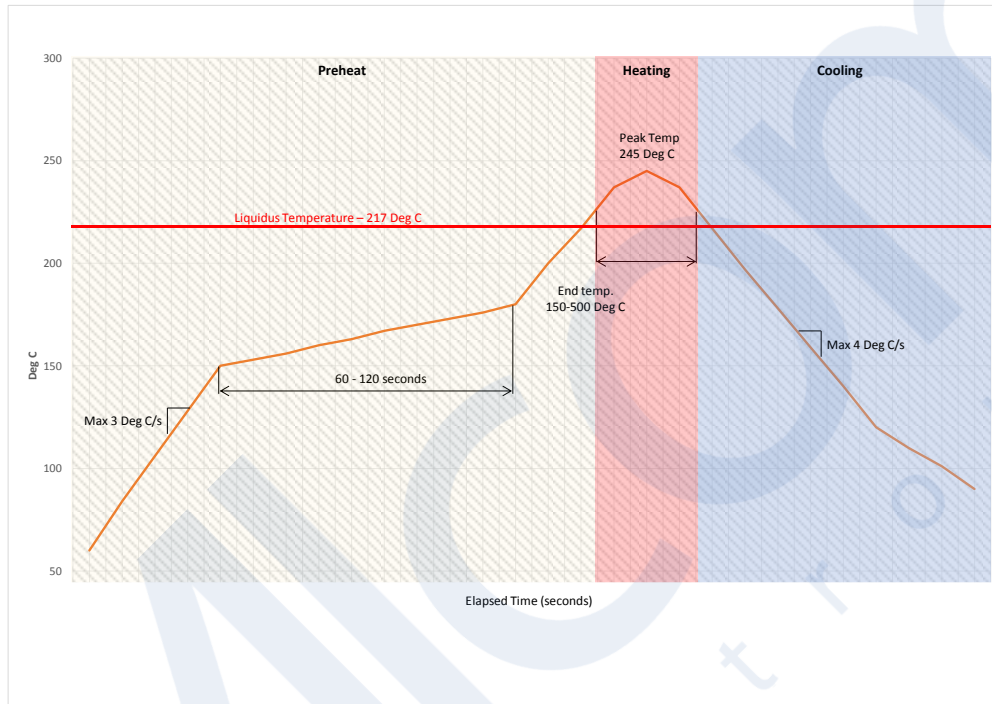

Figure 4 Soldering profile

Please note that whilst every care and attention has been made by LPRS to ensure this profile is correct, each manufacturing process is subtly different and we recommend consulting with your manufacturing facility prior to production to ensure this profile is suitable for use with your overall PCB assembly process.

3.3 Conformal coating.

Conformally coating LPRS's RF products may adversely affect the operation and RF performance of the device and therefore we would not recommend this course of action. If your application requires a coating of some kind, customers should conduct their own tests to ensure suitability. Whilst the RF shielding CAN will provide some protection, all care and attention should be taken to ensure the coating does not flow into the module.

Please note that conformal coating of the module with any substance will invalidate the warranty.

If your application must have a conformal coating, please contact LPRS to discuss further.

3.4 eRA / eRIC Pin compatibility

All eRIC modules are physically compatible in terms of pin assignment with LPRS's eRA modules. Please see below diagram.

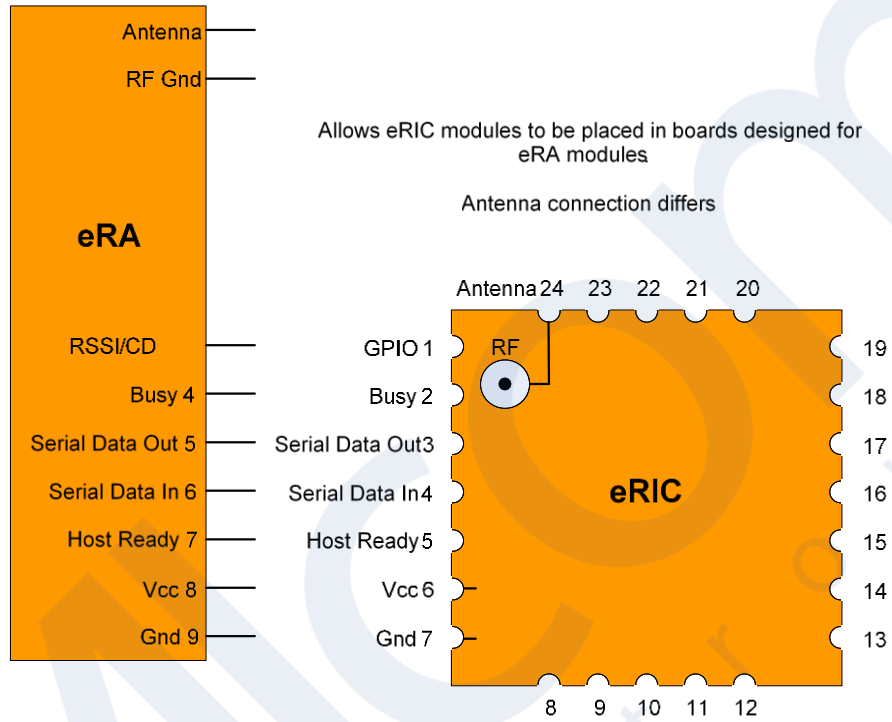

Figure 5 eRA & eRIC Pin Compatibility Diagram

4. Absolute Maximum Ratings

Operating Temperature Range	-40° C to +85° C
Storage Temperature Range	-40° C to +85° C
Vcc	- 0.3 to + 6.0 Volts
All Other Pins (N.B.)	- 0.3 to +3.3 Volts
Antenna	+10dBm (As specified in SX1272 Data Sheet)

Performance Data: eRIC-LoRa. Supply +5.0 Volt ± 5%, Temperature 20° C

DC Parameters	Pin	Min	Typical	Max	Units	Notes
Supply Voltage (Vcc)	6	2.5	3.3-5.0	6.0	Volts	
Transmit supply current	6	18	90	125	mA	40mA at +10dBm 90mA at +17dBm 125 mA at +20dBm (Max 1% Duty Cycle)
Receive supply current	6		16		mA	*2
Sleep mode current	6		15		uA	Both transceiver & MCU are in sleep mode.
Interface Levels						
Data Output Logic 1		2.2	3.1	3.1	Volts	10k load to +Vcc supply
Data Output Logic 0			0.1		Volts	10k load to +Vcc supply
Logic Output Current				25	mA	
Data Input Logic 1		2.0		3.6	Volts	*1
Data Input Logic 0				0.2	Volts	
Input Pull-ups			100		KΩ	*1
RF Parameters						
Antenna Impedance	24		50		Ohms	
Frequency Range		860	-	1000	MHz	Please refer to local ISM licence free radio regulations. See ER Frequency commands
Frequency Region	EU	868	869.85	870	MHz	See ER Configuration commands
	USA	902	903	928	MHz	
RF Power Output	24		+7	+20	dBm	868MHz - 50Ω load *4
	24		+17	+20	dBm	915MHz - 50Ω load *4
Frequency accuracy			±10		ppm	Overall
Harmonics/Spurious Emissions			-47	< -36	dBm	Meets EN 300 220-3
Over Air Bit Rate				300	Kbps	(Not the effective Data Rate)
Receiver		SF6		SF12		
Sensitivity		-122		-137	dBm	At 125kHz bandwidth (SF 6 - 12)
		-119		-134	dBm	At 250kHz bandwidth
		-116		-131	dBm	At 500kHz bandwidth
Serial Data Rate		2.4	19.2	115.2	Kbps	Host interface
Logic Timing						
Initial Power Up Time			1		mS	*2,3,5
Mechanical						
Size			15 x 20 x 2.2		mm	
Pin Pitch			2.54		mm	(Standard 0.1 Inches)
Weight			1.5		grams	

Notes * :

1. The 'Host Ready Input' and the 'Serial Data Input' have 'weak' internal pull-ups enabled.
2. The transceiver will then be ready to receive (default) or transmit. It would normally be left in this powered state ready to receive data.
3. During power-up the 'Busy' Output line initially goes high and then goes low when ready for use
4. Typical values show restricted with 'Worldwide settings' applied.
5. Sleep command. Allow approximately 6mS to wake up from sleep.

5. Logic Levels

The module operates internally from the output of an on-board 3.3 Volt low drop regulator. This regulator will still provide an (un-regulated) output below its drop out voltage, down to the minimum operating voltage (1.8V) of the RF IC which at 2.4V allows up to +20dBm RF output.

The logic levels of the input/output pins are therefore between 0 Volt and the actual output voltage of the internal regulator. Outputs will drive external logic operating at 3.3 Volts. Resistors (1k typical) should be fitted in series with input data lines when interfacing to external logic outputs greater than 3.3Volts or greater than the external supply to prevent driving excess current into inputs and thus damaging them.

The serial inputs and outputs are intended for connection to a UART or similar low voltage logic device. Do not connect any of the inputs or outputs directly to an RS232 port. The transceiver module may be permanently damaged by the voltages (+/- 12V) present on RS232 signal lines.

When Handshaking is enabled the 'Host Ready' Input should be held at 0 Volt (Ground) in order to receive data packets via the UART.

On power up the transceiver is, by default configured to receive data.

6. Power Supply

The supply used to power the transceiver should be 'clean' and free from ripple and noise (<20mV p-p total).

It is suggested that 100nF ceramic capacitors be used to de-couple the supply close to the power pins of the transceiver. The use of 'switch mode' power supplies should generally be avoided as they can generate both conducted and radiated high frequency noise that can be very difficult to eliminate.

This noise may considerably reduce the performance of any radio device that is connected or adjacent to such a supply.

For battery powered applications, we would recommend LPRS's range of 3.6V Lithium primary cells, available in all sizes including ½ AA, A, AAA, C, D, DD which range in capacity from 1.2aH to 19aH.

7. Antennas

The eRIC-LoRa transceiver can be used with the various common types of antenna that match the 50Ω RF Input / Output such as a monopole (whip), a tuned helical antenna, a PCB loop antenna or a ceramic 'chip' antenna.

Monopole antennas are resonant with a length corresponding to one quarter of the electrical wavelength ($\lambda/4$). They are very easy to implement and can simply be a 'piece of wire' or PCB track which at 868MHz should be approximately 8.6cm in length. This should be kept straight, in 'free space' and well away from all other circuitry, conducting objects and metalwork and should preferably be connected directly to the Antenna pin (24) of the transceiver.

If the antenna needs to be remote it should be connected via a 50Ω coaxial feeder cable or transmission line. A 50Ω transmission line can be constructed on FR4 board material by using a 3mm wide PCB track over a ground plane and this should be kept as short as possible.

The eRIC transceiver is also fitted with u.FL RF connector wired in parallel with pin 23 (RF Gnd) and pin 24 (RF In/Out). LPRS can supply suitable antennas fitted with matching connectors and low loss cable assemblies.

Helical antennas are also resonant and generally chosen for their more compact dimensions. They are more difficult to optimise than monopole antennas and are critical with regard to any surrounding conducting objects that can easily 'de-tune' them. They operate most efficiently when there is a substantial ground plane for them to radiate against.

PCB loop antennas are the most compact antennas but are less effective than the other types. They are also more difficult to design and must be carefully 'tuned' for best performance.

Chip antennas are attractive as they are compact and if used in accordance with the manufacturer's specifications can provide very good performance.

The Internet can provide much useful information on the design of Short Range Device (SRD) Antennas.

Please Note: To meet US FCC requirements the modules must be used with the specified antennas (TBA) that were used for testing. Please refer to FCC documentation as available.

7.1 Antennas Approved for use with eRIC-LoRa

Part Number	Gain	Supplier	Notes
ANT-900MS	3dBi	LPRS	
ANT-SS900	2dBi	LPRS	Step files available from www.lprs.co.uk
ANT-SR900	2dBi	LPRS	Step files available from www.lprs.co.uk
ANT-WVP915SMA-Y	2.5dBi	LPRS	

Antennas **must** be used in conjunction with the specified u.FL cable (below) or equivalent:

LPRS Part Number: **LPRS-UFL-N-N-100-SMA-S-F-B** (bulkhead SMA jack) or **LPRS-UFL-N-N-100-SMA-R-F-B** (Right angled SMA)

8. easyRadio eRIC/eRA Configuration Command Set

Key operating parameters of most easyRadio modules can be changed and configured by sending the 'text' (ASCII character) commands detailed below. These commands can be executed using 'easyRadio Companion' software, any 'Terminal' software operating on a PC or from the host microcontroller.

Note: ER commands are non-volatile and stored in the module parameters after power down.

The commands should be sent exactly as shown: i.e. case sensitive with no spaces between characters. Commands are not executed until the Acknowledgement sequence (ACK) is sent to and processed by the module.

To send the commands follow this procedure:

Send Command from host: e.g. ER_CMD#U5 (Set UART BAUD to 38400)

Wait for the completion of the echo of the Command from the module. e.g. ER_CMD#U5

Send the ACK command as the three upper case ASCII characters 'A' 'C' 'K' in sequence with no spaces

If enabled, from version 4.1.16 the module can reply with 'OK' to indicate correct modification of parameters.

Commands ending with '?' of 9-character length do not require any ACK.

Some special commands (noted below) do require an ACK

Host Serial Communication Settings			
Command	UART Data Rate	✓	Tick Indicates Factory Default setting
ER_CMD#U1	2400		
ER_CMD#U2	4800		
ER_CMD#U3	9600		
ER_CMD#U4	19200	✓	Default
ER_CMD#U5	38400		
ER_CMD#U6	31250		MIDI - Musical Instrument Digital Interface (Not supported by PC UARTS)
ER_CMD#U7	76800		(Not supported by PC UARTS)
ER_CMD#U8	115200		
ER_CMD#U?	Get UART Value		The module replies with the current UART data rate value E.g: ER_CMD#U2 - No 'ACK' is required
ER_CMD#A70	No Parity		Data = 1 Start, 8 Data, No Parity, 1 Stop
ER_CMD#A71	Even Parity		Data = 1 Start, 8 Data, 1 Parity, 1 Stop
ER_CMD#A72	Odd Parity		Data = 1 Start, 8 Data, 1 Parity, 1 Stop
ER_CMD#A40	Disable FAST ACK	✓	
ER_CMD#A41	Enable FAST ACK		"FAST ACK" In this mode the procedure to update settings is made much faster. In response to an ER_CMD#x string the TRS/RS module will reply with a single HEX 6 (0x06) which is the ASCII ACK value. The host will then issue the same single byte 0x06 in replacement of the Txt version of "ACK".

Transmit RF Power Output Settings							
			eRIC-LoRa			Units	
			All frequencies			MHz	
ER_CMD#P0			All frequencies from version 4.1.16 and above, use a single table. Maximum limits for the band can be capped using the new W (World Regulations) Command. The default W setting is unrestricted and the user is responsible to comply with local laws.			-1	dBm
ER_CMD#P1		1				dBm	
ER_CMD#P2		3				dBm	
ER_CMD#P3		5				dBm	
ER_CMD#P4		7				dBm	
ER_CMD#P5		9				dBm	
ER_CMD#P6		11				dBm	
ER_CMD#P7		13				dBm	
ER_CMD#P8		15				dBm	
ER_CMD#P9		17				dBm	
ER_CMD#PM		20	dBm*				
			N.B. RF Power Output conforms with and is restricted by EU & US regulations +17dBm selectable firmware/frequency dependent				
			*When using 20dBm output power an absolute maximum duty cycle of 1% should be adhered to. Usage beyond this duty cycle can damage eRIC-LoRa and therefore invalidate the warranty of the device				
ER_CMD#P?	Get Power Value		The module replies with the current power value. e.g: ER_CMD#P9 - No ACK is required.				
RF Channel Settings							
ER_CMD#Cx	Where x = Channel Number in decimal		E.g. For Channel 1: ER_CMD#C1 or ER_CMD#C01 (leading zero) Value saved in non-volatile EEPROM				
ER_CMD#C?	Get Channel Value		The module replies with the current channel setting E.g: ER_CMD#C0 - No ACK is required.				
Signal Bandwidth							
			Bandwidth		Data Rate @ S/F = 10		After sending any of these commands the Channel number will be reset to Channel 0
ER_CMD#B0	Set Signal Bandwidth		125	kHz	977	bps	
ER_CMD#B1	Default 4.1.16+	✓	250	kHz	1953	bps	
ER_CMD#B2			500	kHz	3906	bps	
ER_CMD#B?	Get Signal Bandwidth						
Band Plan							
ER_CMD#b0	EU	✓	869.850		MHz		Band base/start frequency Europe/ USA b6 user configurable using absolute frequency settings.
ER_CMD#b1	USA		903.000		MHz		
ER_CMD#b6	Custom Setting		903.000		MHz		
ER_CMD#b?	Get current Band Plan						
Frequency Settings							
ER_CMD#F	Set Absolute Frequency		Sets the absolute frequency to xxxxxxxx in Hex E.g. ER_CMD#F33D8DB90 sets the radio frequency to 869850000Hz. This will automatically set Band Plan to b6				Frequency of Channel 0
ER_CMD#F?	Get current Frequency value		Returns the current frequency value as 8 bytes of Hex E.g. ER_CMD#F? Returns 33D8DB90 which is 869850000MHz				Frequency of Channel 0
Spreading Factor							
	S/F	Chips	Bandwidth (kHz) & Equivalent Bitrate				Notes
			125	250 ✓	500		
ER_CMD#s0	6	64	9375	18750	37500	bps	
ER_CMD#s1	7	128	5469	10938	21875	bps	
ER_CMD#s2	8	256	3125	6250	12500	bps	
ER_CMD#s3	9	512	1758	3516	7031	bps	
ER_CMD#s4	10	1024	✓ 977	1953	3906	bps	
ER_CMD#s5	11	2048	537	1074	2148	bps	
ER_CMD#s6	12	4096	N/A	586	1171	bps	S/F 12 at 125kHz not supported at this time
ER_CMD#s?	Get Spreading Factor						

Miscellaneous		
ER_CMD#R0	Reset Module (POR)	Reset module, retrieve and restore all Power On Reset values. Note there is no hardware reset pin.
ER_CMD#RI	Reset to Defaults	Restores all factory default settings (Applies to V4.1.16 and above)
ER_CMD#A10	Encryption Off	LPRS Proprietary Encryption for P2P
ER_CMD#A11	Encryption On	
ER_CMD#A50	Handshaking Off	Host Ready (RTS) on pin 5 and Busy (CTS) on pin 2 function. (Handshaking feature applies to V4.1.17 and above)
ER_CMD#A51	Handshaking On	
ER_CMD#a00	RSSI Off	Received Signal Strength Indicator
ER_CMD#a01	RSSI On	Each received packet delivered is preceded by the 8 bit RSSI value of the received packet
ER_CMD#a40	'OK' Confirmation Disabled	When enabled, the transceiver will reply 'OK' following the confirmation 'ACK' from the host.
ER_CMD#a41	'OK' Confirmation Enabled	
ER_CMD#a50	Pin17 Disable Sleep mode	When enabled Pin17 must be held low for normal operation. Setting the pin high puts the transceiver and MCU into sleep mode consuming only 15uA. One set toggle. To disable send ER_CMD#a50.
ER_CMD#a51	Pin17 Enable Sleep mode	
ER_CMD#S0	Sleep Command	Prior to sending this command, set pin 5 High. Following the ACK the current will drop to < 20uA. Pull pin 5 Low to wake from Sleep. (Unrelated to Pin17 Sleep Pin Function). To activate again re-send sleep command. It takes approximately 200uS to enter Sleep and approximately 6mS to wake from Sleep.
Test Modes		
ER_CMD#T3	Get Firmware Revision	Returns module firmware revision string E.g. ERIC-LORA V4.1.16
ER_CMD#T4	RAW Data Out	Output the received data on the CTS pin
ER_CMD#T7	Read on-chip temperature Sensor	Example reply: -15°C or 23°C (This is decimal value in Celsius)
ER_CMD#T7xx	Calibrate on-chip temperature sensor	xx = Actual Temp (only calibrate when above 0 degrees)
ER_CMD#T8	Last Packet RSSI	Returns the Hex value of the RSSI (Received Signal Strength Indicator) register measured on the last valid packet received
Other Special Commands		
ER_CMD#L8?	Get Serial Number	Returns a unique 6 byte module serial number in Hex. E.g. 40 00 56 ACK required. However the internal module serial number is 3 bytes.
ER_CMD#a60	Serial broadcast Off	When enabled appends module's 3 byte serial number to the broadcasted message. From version V4.1.18 + Not available with 12xx, 34xx, 00xx, and ffx group IDs.
ER_CMD#a61	Serial broadcast On	
Worldwide Regulations (Firmware Versions 4.1.16+)		
ER_CMD#W0		Default – No RF Power output restrictions
ER_CMD#W1		EU Regulation Band Restrictions
ER_CMD#W2		USA FCC Restrictions
ER_CMD#W?		Read the current setting
Group ID Setting		
ER_CMD#N0xx	Enable Group ID	E.g. ER_CMD#N04578 sets the group ID as 0x4578 See 8.1 on Group ID number assignment below
ER_CMD#N000	Disable Group ID	
ER_CMD#N0?	Get Group ID	Returns the 4 byte Group ID number in Hex. Requires ACK
Encryption Key		
ER_CMD#N1xx	Set Encryption Key	e.g. ER_CMD#N121F5 = set Encryption Key to 0x21F5
		There is no method to read the Encryption Key for security purposes.

8.1 Reserved LoRa Group ID number assignments.

12xx Reserved for standard LoRa communications
 34xx Reserved for LoRaWAN communications
 00xx and FFxx will default to 12xx

When Group ID's are different to the above reserved values, data is automatically encrypted using LPRS proprietary encryption using the encryption key stored in memory (Default 0000).
 Group ID's can also be modified to increase security to the Key as it is used in the calculation creating a 32-bit seed.

Note on encryption:

eRA-LoRa/eRIC-LoRa modules use LPRS's proprietary rolling encryption algorithm made up from pre-shared key using a 16-bit group ID and 16-bit key (32 bits total key). The key is stored in a protected portion of memory and cannot be read either by hardware tools or via software. Any attempt will be read as 00 or random numbers.

The algorithm does not add any over air byte overhead with redundant bytes like other encryption methods such as AES which add significant time to data packets.
 AES will be added as an alternative in a future release.

8.2 Channel Frequencies

Each channel frequency is calculated relative to the Start Frequency of the channel, the Channel Number and the Channel Spacing/Band width.

Three commands control the values of each of these parameters:

ER_CMD#bn	Where n is the Start Frequency in MHz of the Band Plan being used	b
ER_CMD#Cn	Where n is the integer Channel Number	c
ER_CMD#Bn	Where n is the Channel Spacing/Bandwidth in kHz	s

The centre frequency of each channel is calculated using the formula:

$$\text{Centre Frequency (f)} = b + cs + \frac{s}{2}$$

Where

Band plan Start Frequency
 Channel Number
 Channel Spacing/Bandwidth

Example

b = 0
 c = 1
 s = 500kHz

$$f = 903.000\text{MHz} + 1 \times 500\text{kHz} + 500\text{kHz}/2 = \mathbf{903.750\text{MHz}}$$

8.3 eRIC-LoRa Gateway Mode

Coming Soon. Available via a firmware upgrade.

9. Application & Operation of eRIC-LoRa Transceiver

The diagram below shows a typical system block diagram comprising hosts (user's application) connected to easyRadio transceivers. The hosts (A & B) will be monitoring (collecting data) and/or controlling (sending data) to some real-world application.

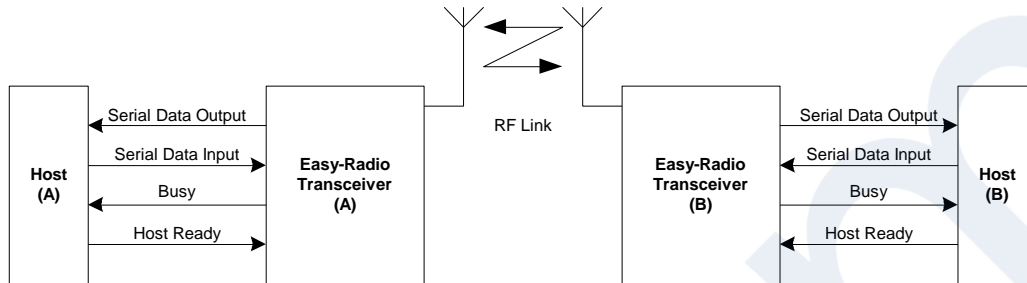

Typical System Block Diagram

The hosts provide serial data input and output lines and two 'handshaking' lines that control the flow of data to and from the easyRadio Transceivers. The 'Busy' output line, when active, indicates that the transceiver is undertaking an internal task and is not ready to receive serial data. The 'Host Ready' input is used to indicate that the host is ready to receive the data held in the buffer of the easyRadio Transceiver.

The host should check before sending data that the 'Busy' line is not high, as this would indicate that the transceiver is unable to reliably receive further data. It should also pull the 'Host Ready' line low and check that no data appears on the Serial Data Output line.

The Busy output is active all the time regardless of handshaking setting. The host Ready is enabled by the handshaking setting command.

Timing Specifications		Units	Notes
Host Serial Input / Output	2400, 4800, 9600, 19200, 38400, 31250 (MIDI), 76800 & 115200	baud	1
Host Character Format	1 Start, 8 Data, No Parity, 1 Stop	Bits	2
End of Data Delay	2 x BAUD Byte Duration	mS	3
RF Transmit duration	Depends on Bandwidth and data rate setting	mS	4
Buffer Size	180	Bytes	5

Notes

1. Data is inverted i.e. Start Bit is logic low. The inputs are intended for direct connection to a microcontroller UART or to RS232 inputs and outputs via an RS232 Level translator such as a Maxim MAX232, which invert the logic of the RS232 signals. This allows direct connection to, for example a microcontroller UART. The data rate is user programmable (Default 19200 baud) and may differ between individual units within a system.
2. 1 start, 8 data, 1 stop = 10 bits @ 104uS/bit = 0.52mS/character at 19200 Baud. (Default)
3. The 'End of Data' delay is fixed at twice the character time.
4. A fixed package overhead of xx is added to all packets.
5. The buffer size is limited to 180 bytes. Sending more than 180 bytes will cause loss of data.
6. CTS pin will go high 2 bytes before the buffer is full. This allows characters already sent to be accepted by the ER module.

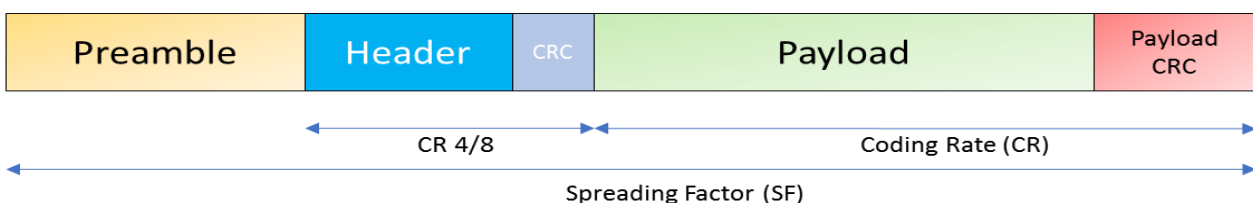

eRIC-LoRa Modem Packet formatting.

9.1 SX1272 SPI Direct Mode

Sending the command ER_CMDL402DC followed by a power-on reset enables the eRIC -LoRa module to create a pass through and therefore direct access to the SX1272 chip. The table below shows the pin assignments.

eRIC Pin	SX1272	Description
1-7	NA	As standard.
8	DIO_0	Direct
9	DIO_1	Direct
10	DIO_2	Direct
11	DIO_3	Direct
12	DIO_4	Direct
13	DIO_5	Direct
17	SCK	Bridged via software
18	MISO	Bridged via software
19	MOSI	Bridged via software
20	NSS	Bridged via software

9.2 Transmission restrictions

As with all devices using the ISM license free radio spectrum, LPRS's eRIC-LoRa must comply with regional restrictions on spectrum access and use. Restrictions are usually limited to 4 main topics:

- 1) Operational frequency band (What frequency you are using to transmit data on).
- 2) Maximum effective radiated power (How much output power you are using to transmit).
- 3) Channel access (aka Duty Cycle, how long you are transmitting for each time you transmit and how often you are transmitting).
- 4) Maximum occupied bandwidth (How much of the band you can transmit over).

9.3 eRIC-LoRa transmission guide

eRIC-LoRa is extremely flexible and capable of transmitting within whatever local restrictions you may have. As a guide please see below an indication of how often / how much eRIC-LoRa can be used:

Region	Frequency	Output Power	Duty Cycle	Bandwidth
EU (CE/RED)	868.0MHz – 868.6MHz	25mW (+13dBm)	1%	Whole band
EU (CE/RED)	869.4MHz – 868.65MHz	500mW (+26.9Bm)	10%	Whole band
EU (CE/RED)	869.7MHz – 870.0MHz	5mW (+13dBm)	100%	Whole band
USA (FCC)				

Please note: Information provided for guidance only, customers should conduct their own investigations into local regulations and restrictions.

Please contact LPRS to discuss the best operating profile for your device.

10. Product Order Code

Name	Description	Order Code
eRIC-LoRa	CE/FCC Certified Radio Module	ERIC-LORA

Please contact the sales office for availability of other variants of the standard product. The software interface can be customised to specific requirements for high volume applications.

10.1 Firmware

eRIC-LoRa will be supplied with the latest release of firmware unless otherwise specified. Please contact LPRS to discuss being supplied with an eRIC-LoRa with a previous or custom version of firmware.

10.2 Programming Modules in Situ

LPRS recommends customers make provision for programming the modules firmware physically through their host MCU or separate programming port.

10.3 MTBF

The mean time before failure is >100 Years.

11. Regulatory Approvals

eRIC-LoRa is approved in accordance with CE/EU/RED and FCC regulatory approvals for devices using the Industrial, Scientific and Medical (ISM) license free radio spectrum.

LPRS approves our devices to these levels meaning customers benefit from reduced product testing by using our pre-approval certificates. For the latest up-to-date certificates please follow the below link to our website.:

<http://www.lprs.co.uk/knowledge-centre/regulatory-approvals.html>

See section 9.1 for Duty cycle restrictions.

11.1 FCC Statement:

- This device complies with Part 15 of the FCC Rules. Operation is subject to the following two conditions:
 - (1) This device may not cause harmful interference, and
 - (2) This device must accept any interference received, including interference that may cause undesired operation.
- This equipment complies with FCC radiation exposure limits set forth for an uncontrolled environment. End users must follow the specific operating instructions for satisfying RF exposure compliance. This transmitter must not be co-located or operated in conjunction with any other antenna or transmitter. This device should not be used with antennas other than those specified below or those of less or equal gain to the maximum gain used in the table below.
- Changes or modifications not expressly approved by the party responsible for compliance could void the user's authority to operate the equipment.

12. eRIC-LoRa Firmware Versions

Version	Date	Revision	Known Issues
4.1.11	January 2016	Initial Release	Temperature Sensor not working
4.1.16	March 2018		Odd/Even Parity not working properly. Fixed
4.1.17	June 2018		Handshaking bug. Fixed
4.1.18	January 2019		Serial Broadcast feature added
4.1.19	May 2019		High power issue. False reset on P9. Fixed.
4.1.21	September 2019		Only Group ID 12xx & 34xx working. Fixed

13. Document History

Issue	Date	Revision
0.1	February 2017	Provisional datasheet
0.2	May 2017	Minor corrections
1.0	May 2017	Release
1.1	June 2017	Typo corrections
1.2	November 2017	Clarification of Min / Max operating frequency
1.31	January 2018	Corrections and clarifications
1.32	February 2018	Corrections and amendments
1.41	January 2019	Serial Number Broadcast addition. Minor corrections and command additions.
1.42	May 2019	MTBF and programming method added. Latest firmware
1.43	November 2019	Reflow diagram added. SPI direct mode added.

Changes to this Document

This data sheet has been updated to reflect changes throughout the range of LPRS modules. Specific changes are recorded in the documentation history above.

Copyright

See: www.lprs.co.uk

Disclaimer

See: www.lprs.co.uk

Terms and Conditions of Use

See: www.lprs.co.uk

Contact Information

For further information or technical assistance please contact:

