



Datasheet

Raptor Max

Part No:
MAX1016.W.001

Description

16-in-1 Permanent Mount Antenna White with Multiband GNSS, 8 5G/4G, 6 Wi-Fi & 1 LMR Whip with Staggered RG-174/TGC-1.5DS Cables

Features:

- Low-profile, IP67 rated Enclosure
- 8* 5G/4G MIMO 617~6000MHz
- 6* WIFI MIMO 2.4/5.8/7.125GHz
- 1* GNSS L1/L5 Dual-band Antenna
- 1* LMR/TETRA Interchangeable Whip
- Dims: 330mm * 75.5mm * 45.2mm
- RoHS & Reach Compliant

1. Introduction	3
2. Specification	4
3. Mechanical Drawing	8
4. Packaging	9
5. Installation Recommendation	10
6. Antenna Characteristics	11
7. Active Antenna Characteristics	22
8. Radiation Patterns	27
<hr/>	
Changelog	152

Taoglas makes no warranties based on the accuracy or completeness of the contents of this document and reserves the right to make changes to specifications and product descriptions at any time without notice. Taoglas reserves all rights to this document and the information contained herein. Reproduction, use or disclosure to third parties without express permission is strictly prohibited.

1. Introduction



The Taoglas® Raptor MAX series of concept combination antenna are designed to enhance the connectivity options available to you for your vehicle. With up to 16-in-1 connections available, in combinations of Multiband GNSS, 5G/4G MIMO, Wi-Fi MIMO, LMR/VHF/UHF/Tetra, this next generation, super low-profile vehicle roof mount antenna eliminates the need for multiple antenna installations.

The MAX1016 can be configured in any combination of multiband GNSS (L1/L5), up to 8 5G/4G antennas, up to 6 Wi-Fi antennas and LMR/Tetra. Each of the Cellular antennas covers all global 5G/4G bands from 600 to 6000MHz with great efficiency across all bands. The Wi-Fi antennas are designed for Wi-Fi 6e/7 coverage on bands 2.4, 5.8 and 7.125GHz. The embedded multiband active GNSS antenna covers both the L1 and L5 bands, helping you achieve a much greater positional accuracy than from single GNSS. The interchangeable whip allows you the add frequency bands specific to your requirements either in the LMR or TETRA ranges.

The antenna comes with low-loss TGC-1.5DS coaxial pigtail cables as standard, terminating in SMA(M) / RP-SMA(M), with custom configurations depending on your requirements. The super low profile, fully IP67 rated waterproof enclosure is manufactured from a robust, UV protected ABS material, ideal for use in any environment or weather condition.

Several configurations in both black and white will be available as standard, see below, but other configurations are available upon request, contact your local Taoglas customer service team for more information.

Raptor Max SKU's and Configurations:

MAX1008	8x 5G/4G
MAX1009	1x GNSS & 8x 5G/4G
MAX1012	1x GNSS, 8x 5G/4G & 3x Wi-Fi
MAX1012	1x GNSS, 8x 5G/4G & 4x Wi-Fi
MAX1014	1x GNSS, 8x 5G/4G & 5x Wi-Fi
MAX1015	1x GNSS, 8x 5G/4G & 6x Wi-Fi
MAX1016	1x GNSS, 8x 5G/4G, 6x Wi-Fi & 1x LMR Whip

2. Specification

GNSS Frequency Bands					
GPS	L1 1575.42 MHz	L2 1227.6 MHz	L5 1176.45 MHz		
GLONASS	G1 1602 MHz	G2 1248 MHz	G3 1207 MHz		
Galileo	E1 1575.24 MHz	E5a 1176.45 MHz	E5b 1201.5 MHz	E6 1278.75 MHz	
BeiDou	B1C 1575.42 MHz	B1I 1561 MHz	B2a 1176.45 MHz	B2b 1207.14 MHz	B3 1268.52 MHz
L-Band	L-Band 1542 MHz				
QZSS (Regional)	L1 1575.42 MHz	L2C 1227.6 MHz	L5 1176.45 MHz	L6 1278.75e6	
IRNSS (Regional)	L5 1176.45 MHz				
SBAS	L1/E1/B1 1575.42 MHz	L5/B2a/E5a 1176.45 MHz	G1 1602 MHz	G2 1248 MHz	G3 1207 MHz



GNSS Bands and Constellations



Changelog for the datasheet

SPE-24-8-195 - MAX1016.W.001

Revision: A (Original First Release)	
Date:	2024-08-19
Notes:	Initial Release
Author:	Gary West

Previous Revisions

Revision	Date	Notes

GNSS Electrical			
Frequency (MHz)	1176.45	1561	1575.42
VSWR (max.)	3:1	3:1	3:1
Passive Antenna Efficiency (%)	37.77	33.44	40.65
Passive Antenna Gain at Zenith (dBi)	1.75	3.59	4.51
Polarization	Linear		
Impedance	50 Ω		

LNA and Electrical Properties				
Frequency (MHz)	1176.45	1561	1575.42	1602
Gain(dB)	29.7	28.8	28.1	28.6
Noise Figure (dB)	2.9	2.8	2.9	2.3
Input Voltage (V)	+ 1.8 to 5.5			
Current consumption (mA)	5 ± 2			
IEC61000-4-2 (ESD protection)	± 30 kV air / ± 20kV contact discharge			

Cellular Electrical									
Band	Frequency (MHz)	Antenna MIMO	Efficiency (%)	Average Gain (dB)	Peak Gain (dBi)	Impedance	Polarization	Radiation Pattern	Max. input power
5G NR/4G Band 71	617-698	Cellular1	27.0	-5.69	2.03	50 Ω	Linear	Omni	10W
		Cellular2	20.4	-6.91	-1.50				
		Cellular3	25.6	-5.92	0.17				
		Cellular4	44.1	-3.56	3.54				
		Cellular5	24.9	-6.04	2.68				
		Cellular6	24.5	-6.11	-0.41				
		Cellular7	25.1	-6.00	-1.18				
		Cellular8	29.9	-5.24	0.85				
4G/3G Band 12,13,14,17,28,29	698-824	Cellular1	34.1	-4.67	2.63				
		Cellular2	32.0	-4.95	1.92				
		Cellular3	35.7	-4.48	2.67				
		Cellular4	42.9	-3.67	2.75				
		Cellular5	32.0	-4.95	1.77				
		Cellular6	26.4	-5.79	-0.11				
		Cellular7	32.9	-4.83	1.97				
		Cellular8	36.4	-4.39	2.24				
4G/3G/NB-IoT/Cat M Band 5,8,18,19,20,26,27	824-960	Cellular1	38.3	-4.16	1.52				
		Cellular2	36.0	-4.44	1.50				
		Cellular3	28.3	-5.48	1.20				
		Cellular4	35.5	-4.49	2.45				
		Cellular5	29.9	-5.24	1.53				
		Cellular6	28.7	-5.43	-0.35				
		Cellular7	36.3	-4.40	2.66				
		Cellular8	40.1	-3.97	2.58				
5G NR/4G Band 21,32,74,75,76	1427-1518	Cellular1	37.4	-4.27	2.73				
		Cellular2	41.9	-3.78	3.32				
		Cellular3	33.1	-4.81	2.78				
		Cellular4	32.9	-4.82	2.33				
		Cellular5	31.2	-5.06	2.10				
		Cellular6	31.5	-5.01	1.43				
		Cellular7	39.7	-4.02	2.25				
		Cellular8	25.7	-5.91	0.94				
4G/3G Band 1,2,3,4,9,23,25,35,39,66	1710-2200	Cellular1	46.4	-3.34	4.93				
		Cellular2	47.2	-3.26	4.61				
		Cellular3	51.5	-2.88	5.48				
		Cellular4	48.7	-3.13	5.34				
		Cellular5	51.5	-2.88	6.07				
		Cellular6	49.3	-3.07	6.07				
		Cellular7	29.8	-5.26	4.22				
		Cellular8	31.3	-5.04	2.93				
4G/3G Band 7,30,38,40,41	2300-2690	Cellular1	49.9	-3.02	5.47				
		Cellular2	48.3	-3.16	4.39				
		Cellular3	48.2	-3.17	6.12				
		Cellular4	38.8	-4.12	6.69				
		Cellular5	39.2	-4.07	5.96				
		Cellular6	49.2	-3.08	6.79				
		Cellular7	39.7	-4.01	5.28				
		Cellular8	43.1	-3.65	6.09				
5G NR/4G Band 22,42,48,77,78,79	3300-5000	Cellular1	51.4	-2.89	6.13				
		Cellular2	44.9	-3.46	7.46				
		Cellular3	47.4	-3.24	5.75				
		Cellular4	48.2	-3.17	6.88				
		Cellular5	42.5	-3.72	5.24				
		Cellular6	46.2	-3.35	5.90				
		Cellular7	43.1	-3.65	5.37				
		Cellular8	46.1	-3.36	6.02				
LTE5200/Wi-Fi5800	5150-5925	Cellular1	43.2	-3.65	7.96				
		Cellular2	42.7	-3.69	7.82				
		Cellular3	43.4	-3.63	5.67				
		Cellular4	46.5	-3.33	5.73				
		Cellular5	42.7	-3.70	5.26				
		Cellular6	43.6	-3.61	5.84				
		Cellular7	40.1	-3.97	6.03				
		Cellular8	44.6	-3.50	6.14				

8.125 Wi-Fi6 Patterns at 6525 MHz

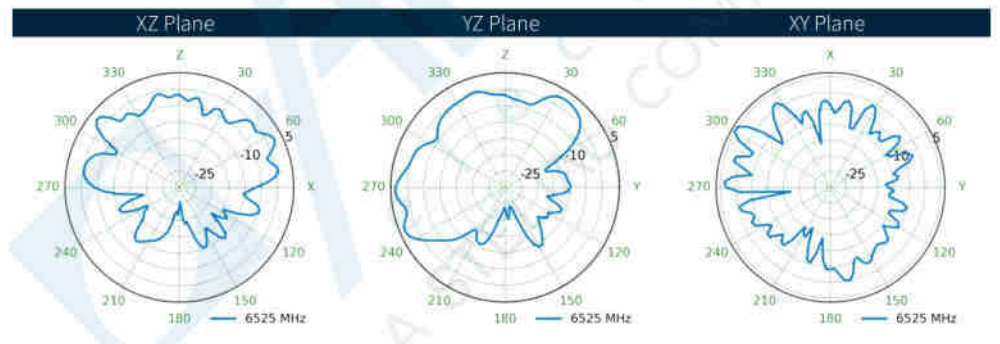
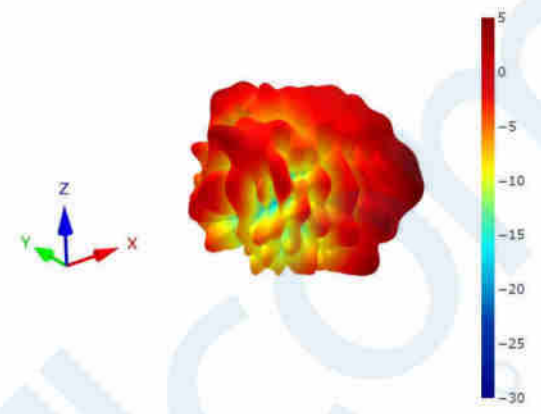

8.124 Wi-Fi5 Patterns at 6525 MHz

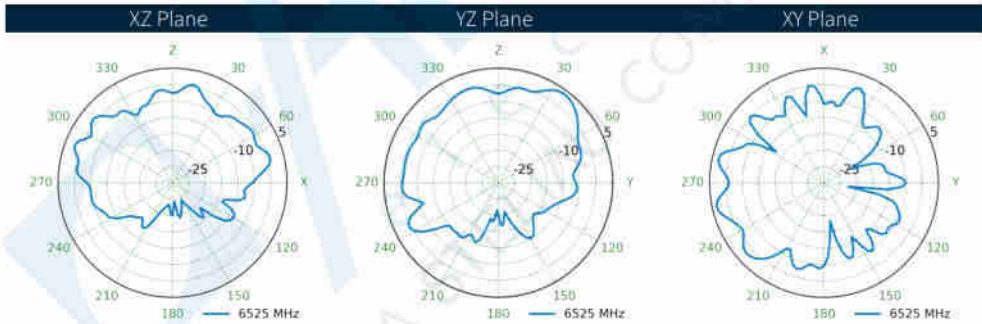
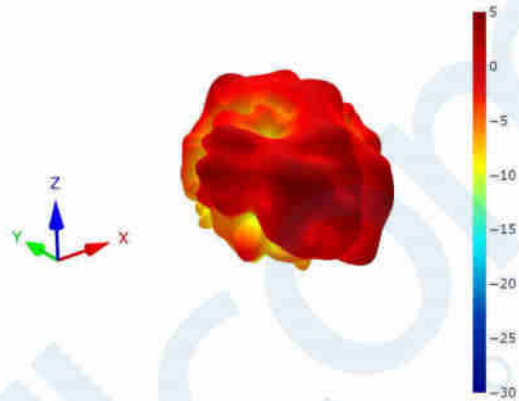

Wi-Fi Electrical									
Band	Frequency (MHz)	Antenna MIMO	Efficiency (%)	Average Gain (dB)	Peak Gain (dBi)	Impedance	Polarization	Radiation Pattern	Max. input power
Wi-Fi - 2GHz	2400-2500	Wi-Fi1	56.5	-2.48	4.36	50 Ω	Linear	Omni	10W
		Wi-Fi2	58.2	-2.35	6.55				
		Wi-Fi3	56.1	-2.51	5.68				
		Wi-Fi4	58.1	-2.36	4.19				
		Wi-Fi5	53.3	-2.73	7.60				
		Wi-Fi6	52.7	-2.78	6.98				
Wi-Fi - 5GHz	5150-5850	Wi-Fi1	49.3	-3.07	5.71				
		Wi-Fi2	49.5	-3.05	7.47				
		Wi-Fi3	47.8	-3.20	5.63				
		Wi-Fi4	45.9	-3.38	6.10				
		Wi-Fi5	50.5	-2.97	8.04				
		Wi-Fi6	44.7	-3.50	8.51				
Wi-Fi - 6GHz	5925-7125	Wi-Fi1	47.1	-3.27	6.33				
		Wi-Fi2	49.9	-3.02	7.47				
		Wi-Fi3	48.4	-3.15	6.28				
		Wi-Fi4	43.1	-3.66	5.96				
		Wi-Fi5	46.2	-3.36	7.31				
		Wi-Fi6	43.7	-3.60	7.22				

Mechanical	
Dimensions	330 x 75.5 x 45.2mm
Material	PC
Connector	SMA(M) and RP-SMA(M) - See Page 8 for more details
Cable	RG-174 and TGC-1.5DS - See Page 8 for more details
IK Impact Rating	IK08 - 5 Joules / 1.7Kg dropped from 300mm
Weight	972g
Environmental	
Temperature Range	-40 ~ +85°C
Relative Humidity	Non-condensing 65°C 95% RH
Ingress Protection	IP67
RoHS & REACH Compliant	Yes

3. Mechanical Drawing

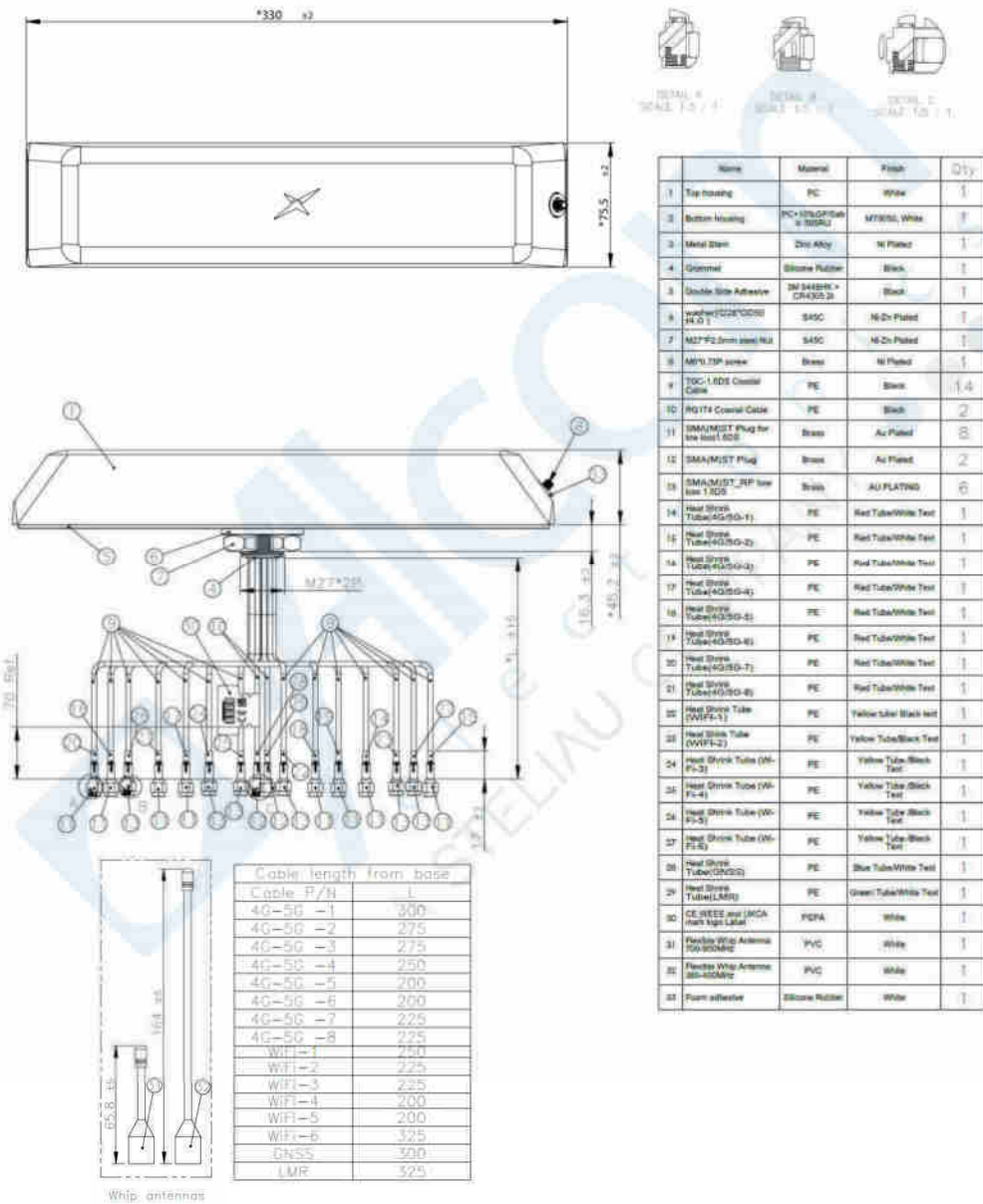

8.123 Wi-Fi4 Patterns at 6525 MHz

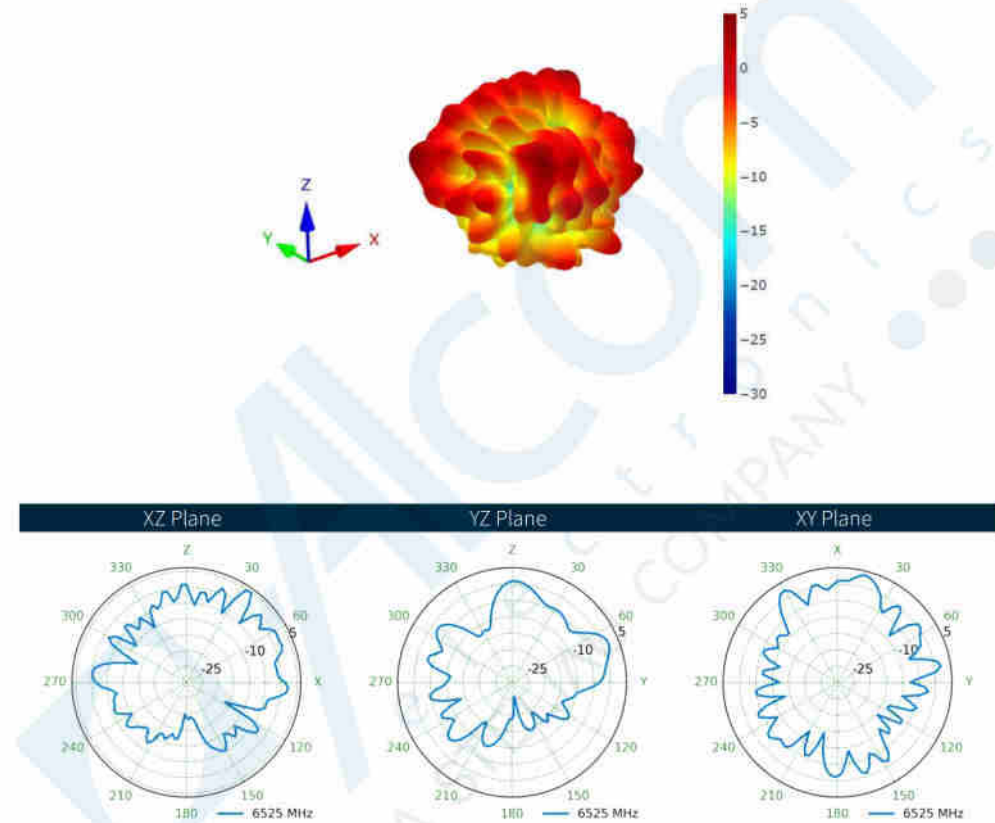

8.122 Wi-Fi3 Patterns at 6525 MHz

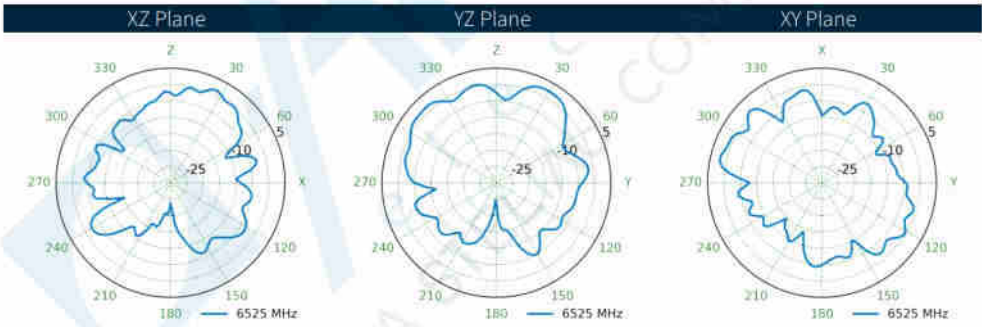
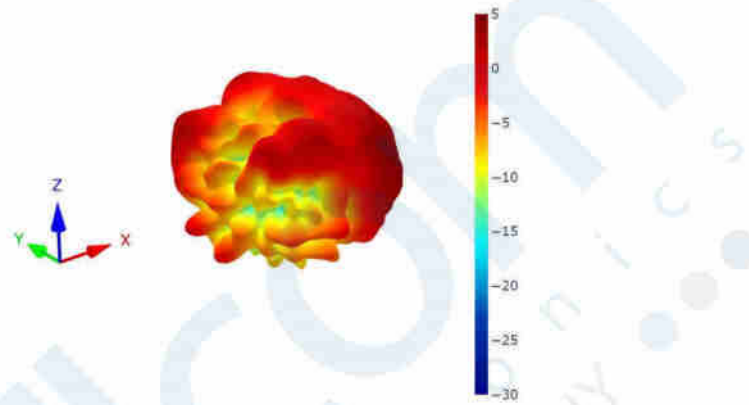

4. Packaging

1pc Small Whip per PE Bag

1pc Large Whip per PE Bag

1pc Antenna per Large PE Bag
 Bag Dimensions: 470x470mm
 Weight: 0.58Kg

8pcs per Carton
 Carton Dimensions: 370x370x300mm
 Weight: 6.1Kg



5. Installation Recommendation

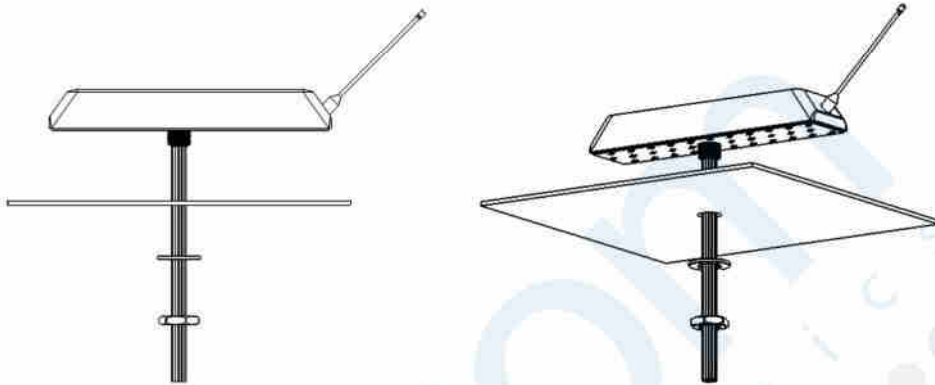

Correct installation of the Raptor Max is required to ensure that the waterproof integrity of the vehicle or enclosure is not compromised.

Step 1: Drill the recommended 30mm diameter hole as indicated below.

Step 2: Ensure that the surface you are mounting to is clean, dry and flat to receive the Raptor Max.

Step 3: Feed the cables through the hole and remove the 3m adhesive backing from the base.

Step 4: Position the Raptor Max into the correct orientation on the mounting surface and firmly press down to activate the 3M adhesive.

Step 5: To permanently mount the antenna, slide the washer and nut over the cable assembly and hand tighten to ensure a secure fit.

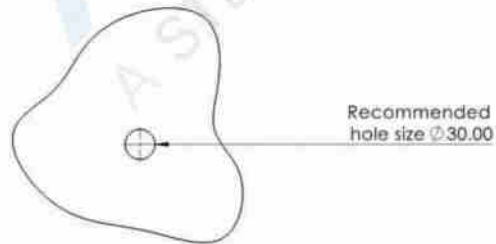

8.121 Wi-Fi2 Patterns at 6525 MHz

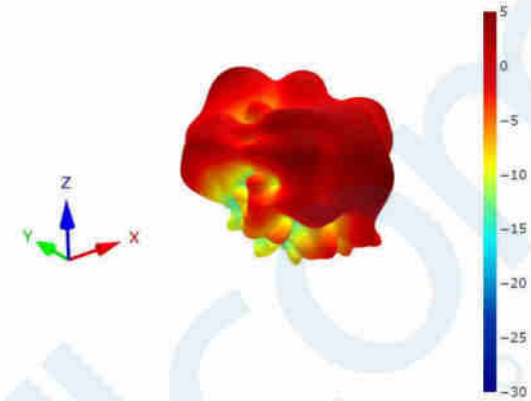

XZ Plane

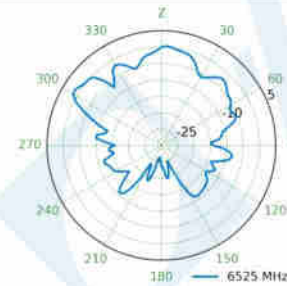

YZ Plane

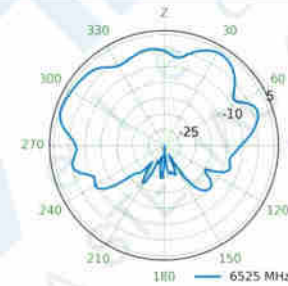

XY Plane

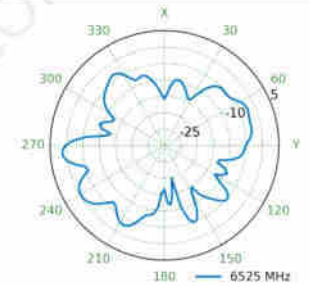

8.120 Wi-Fi1 Patterns at 6525 MHz

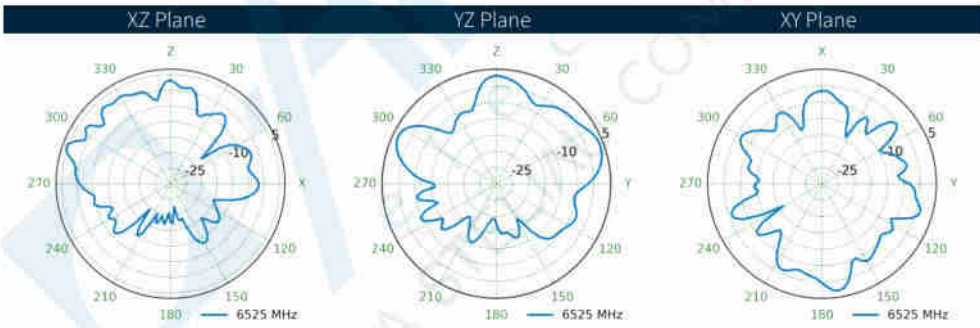
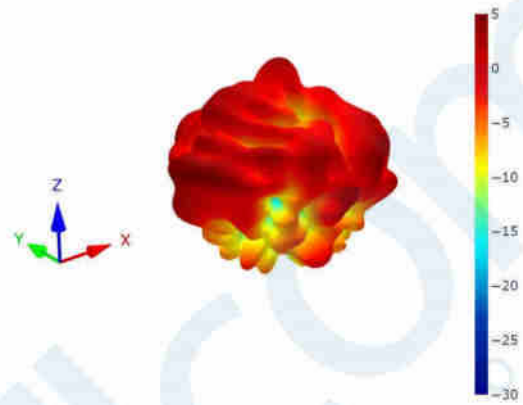

6. Antenna Characteristics

6.1 Test Setup



VNA Test Set-up

6.2 GNSS - Return Loss

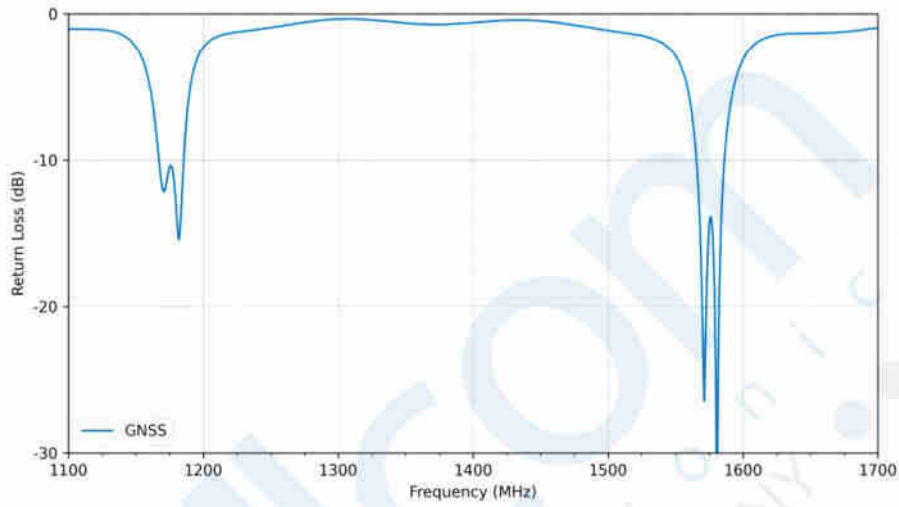

GNSS - VSWR

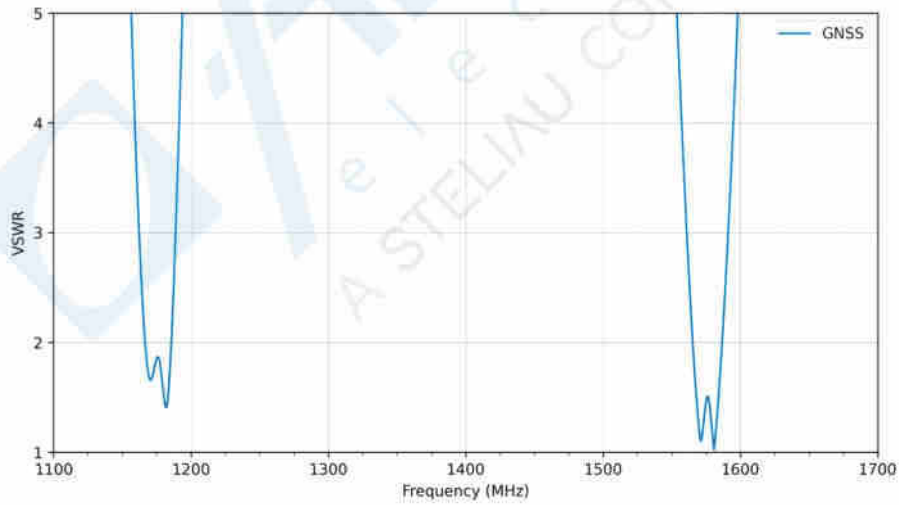

8.119 Wi-Fi6 Patterns at 5490 MHz

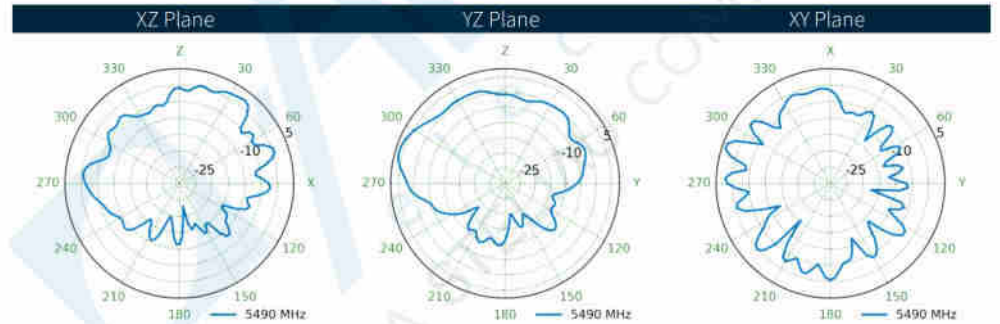
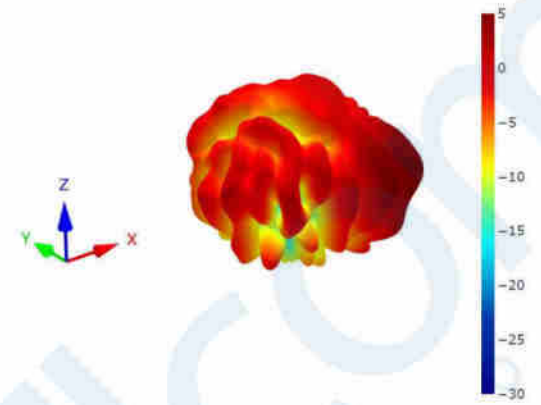

8.118 Wi-Fi5 Patterns at 5490 MHz

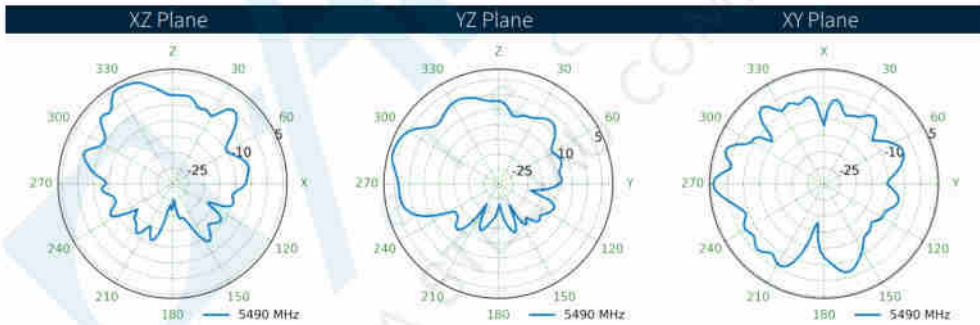
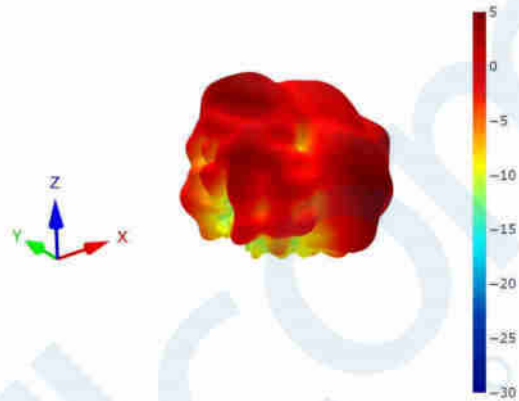

6.4 GNSS - Efficiency

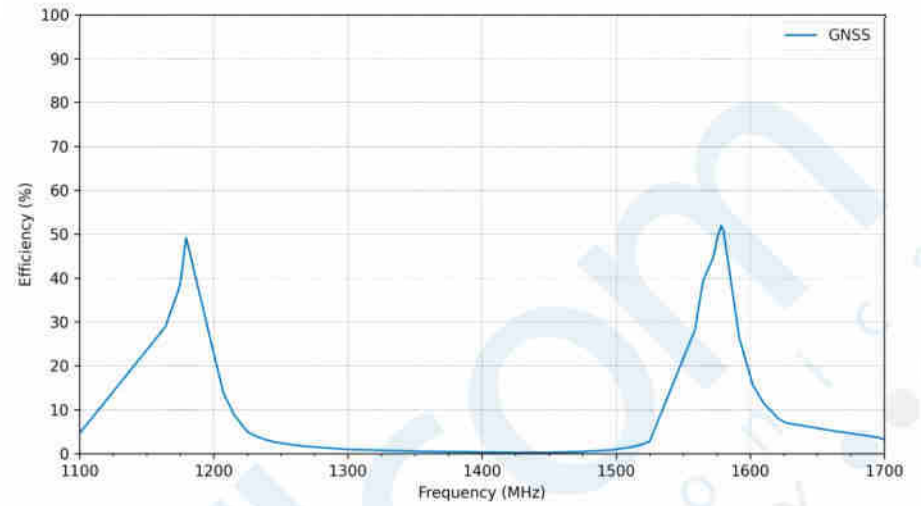

6.5 GNSS - Average Gain

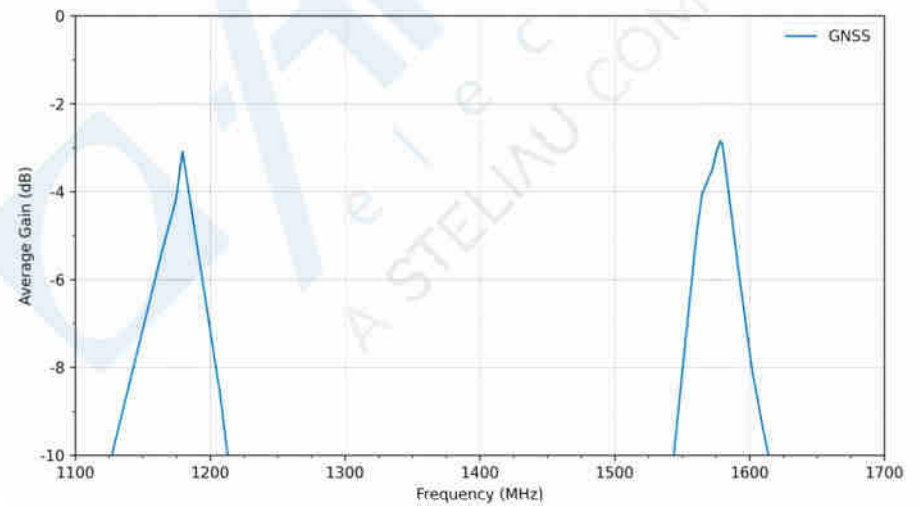

6.6 GNSS - Peak Gain

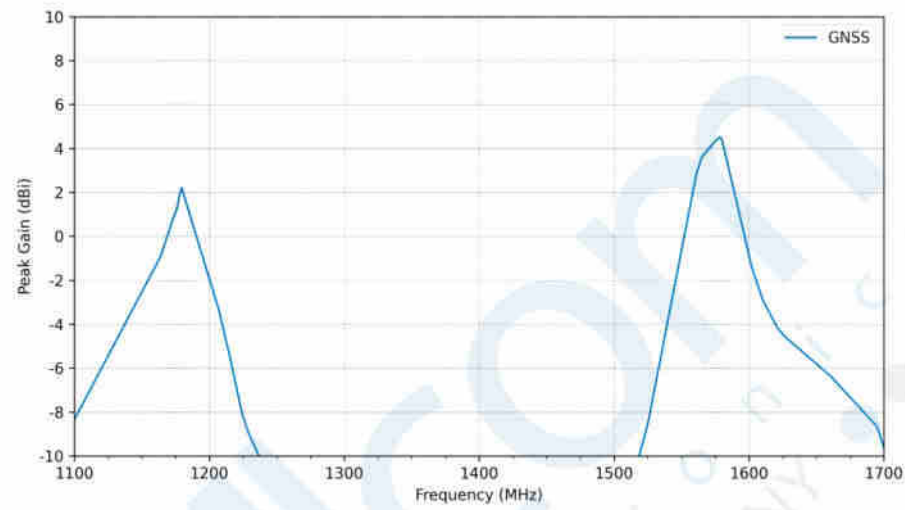

8.117 Wi-Fi4 Patterns at 5490 MHz

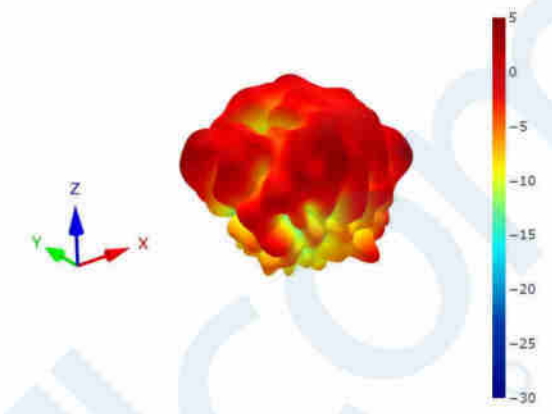

Cellular - Return Loss

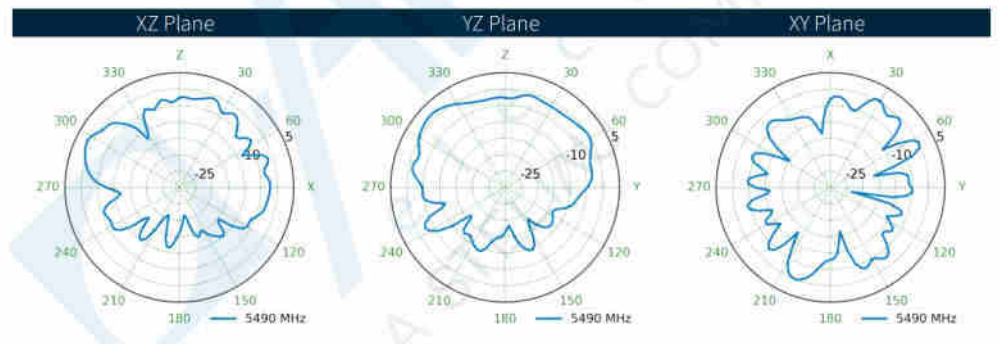
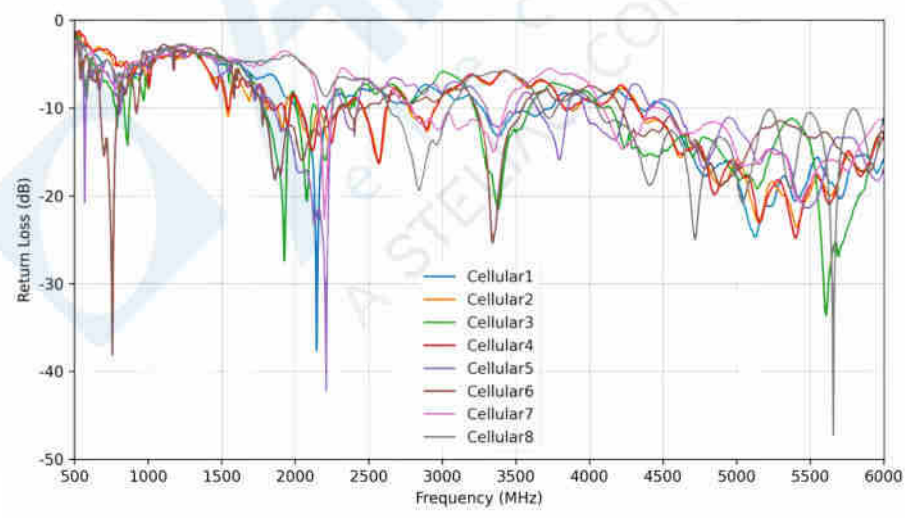

8.116 Wi-Fi3 Patterns at 5490 MHz

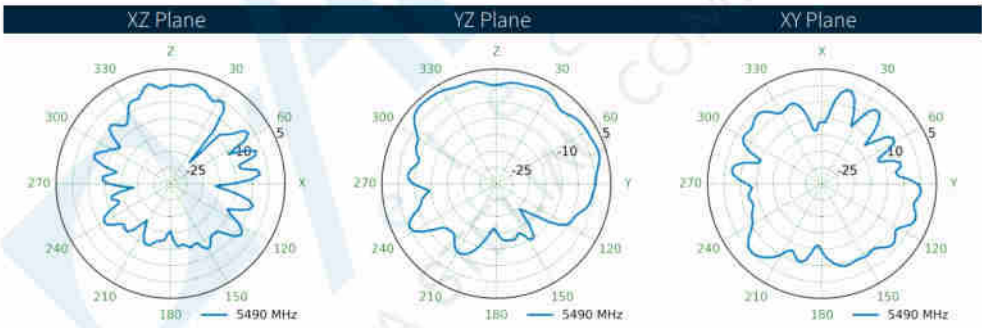
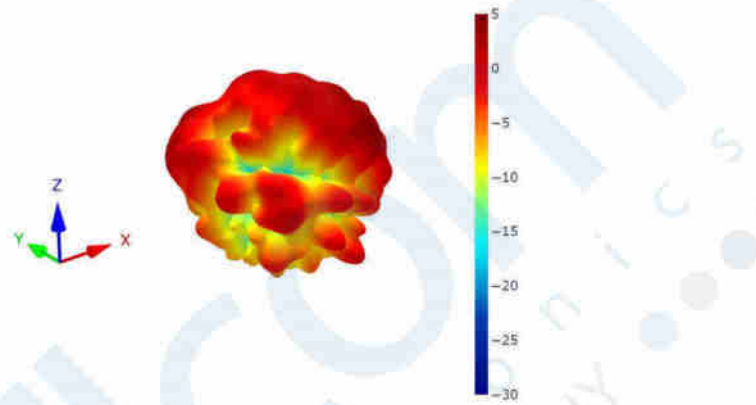

6.1 Cellular - VSWR

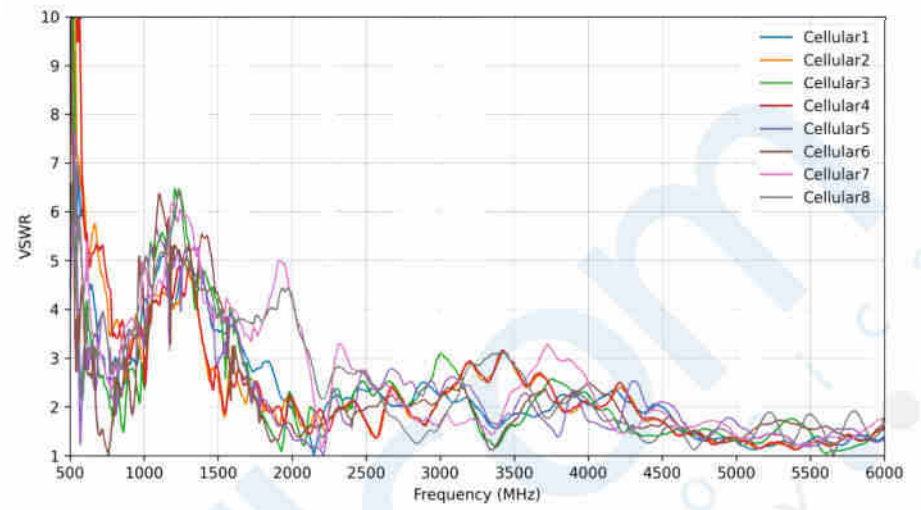

6 Isolation

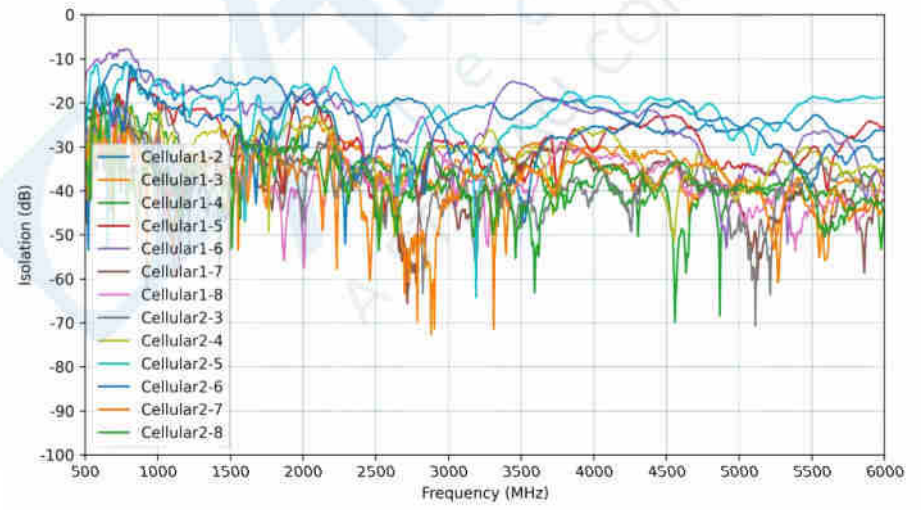

6.10 Isolation

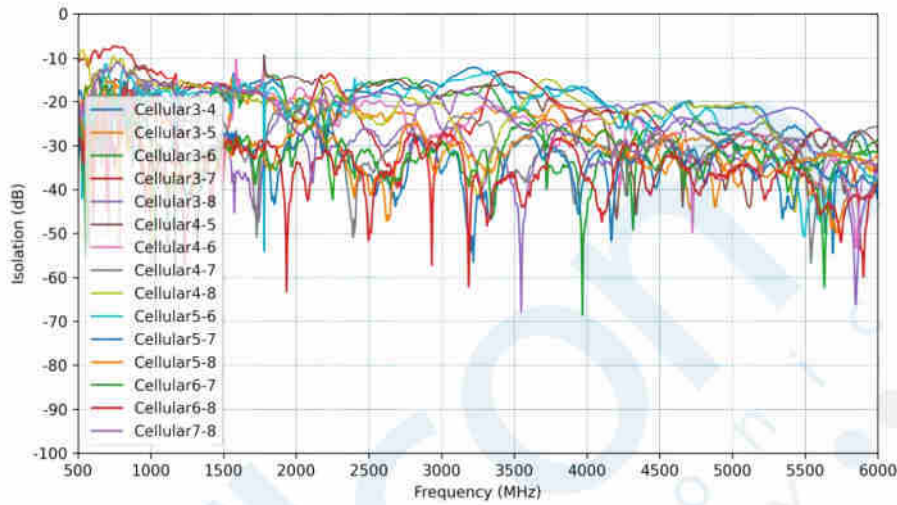

6.11 Cellular - Efficiency

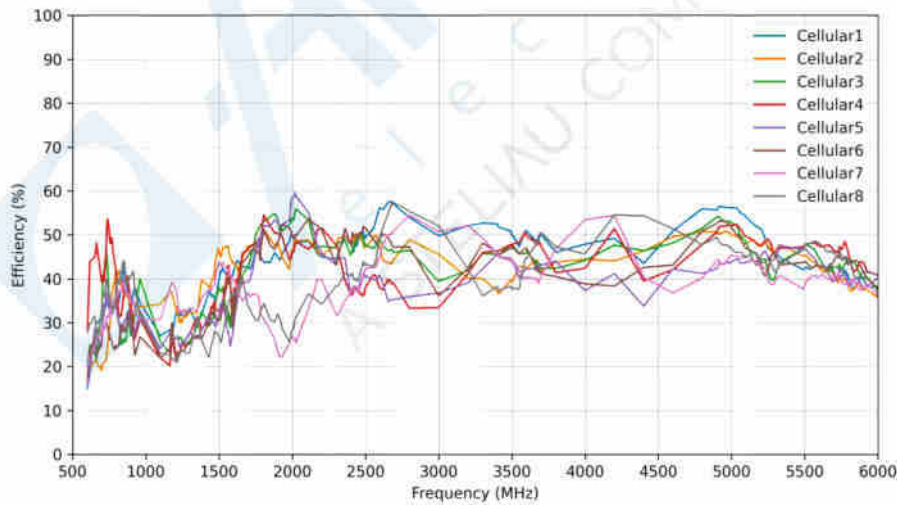

8.115 Wi-Fi2 Patterns at 5490 MHz

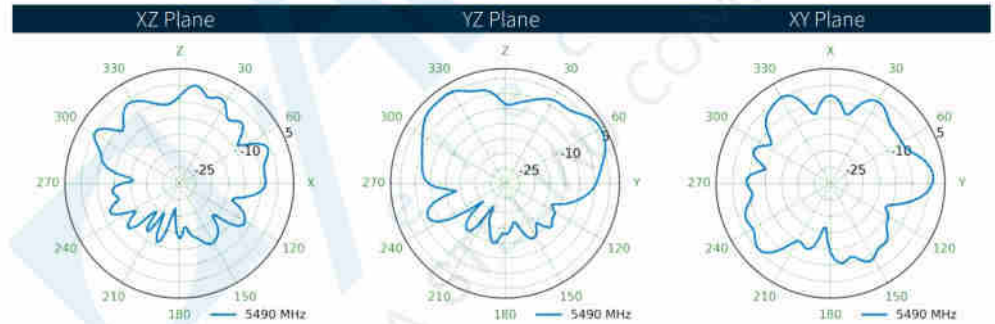
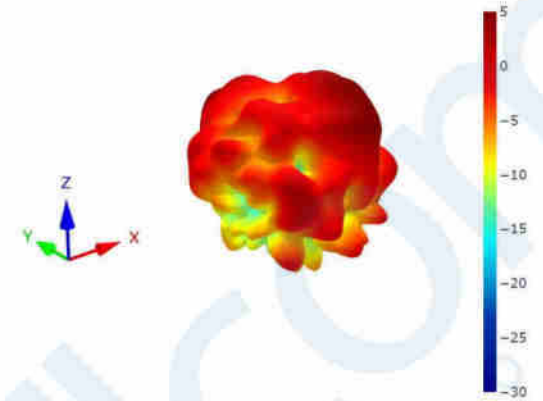

8.114 Wi-Fi1 Patterns at 5490 MHz

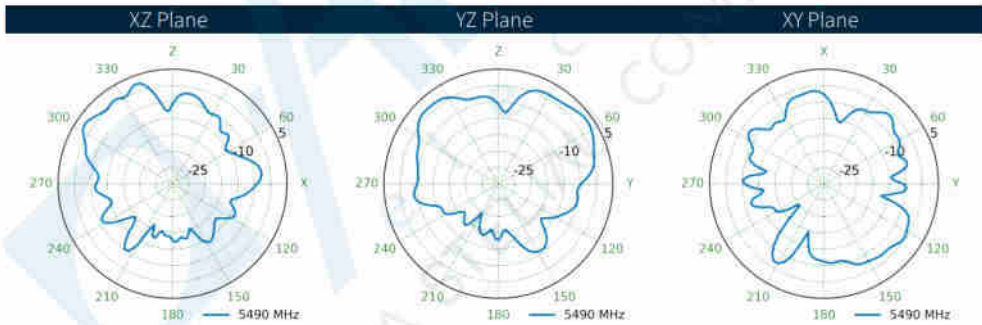
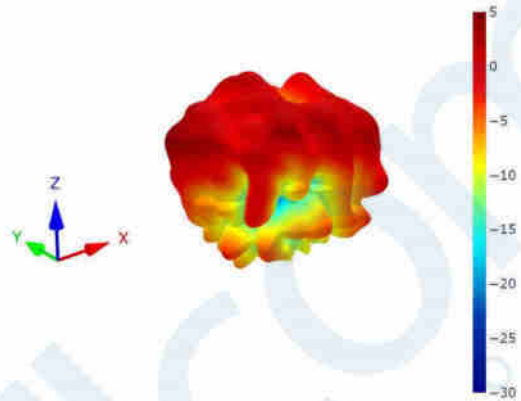

6.12 Cellular - Average Gain

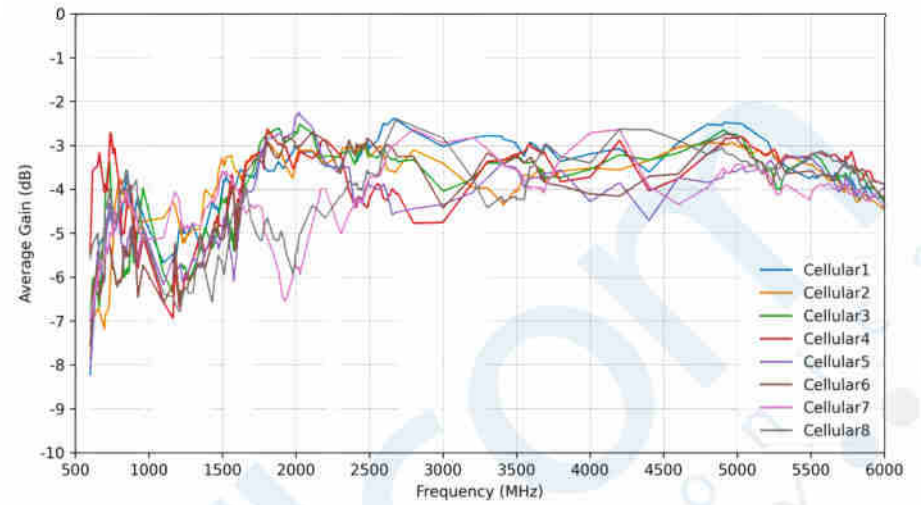

6.13 Cellular - Peak Gain

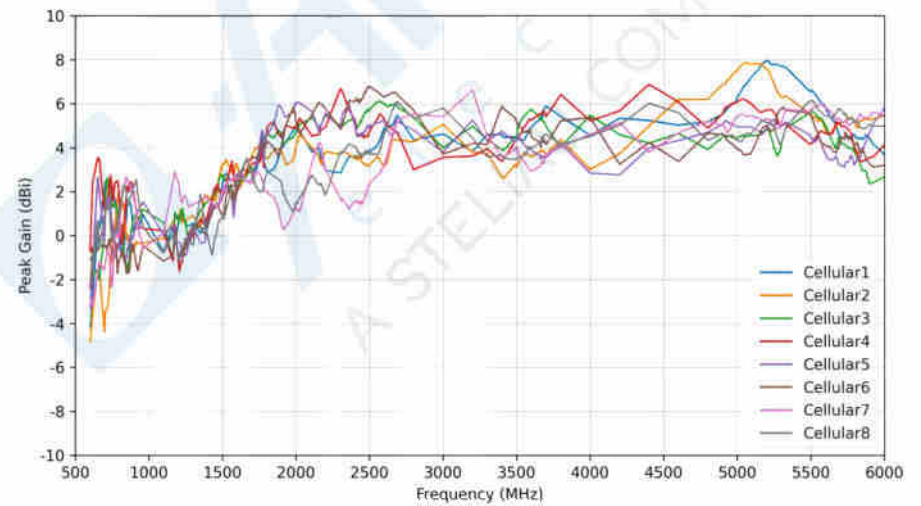

6.14 Wi-Fi - Return Loss

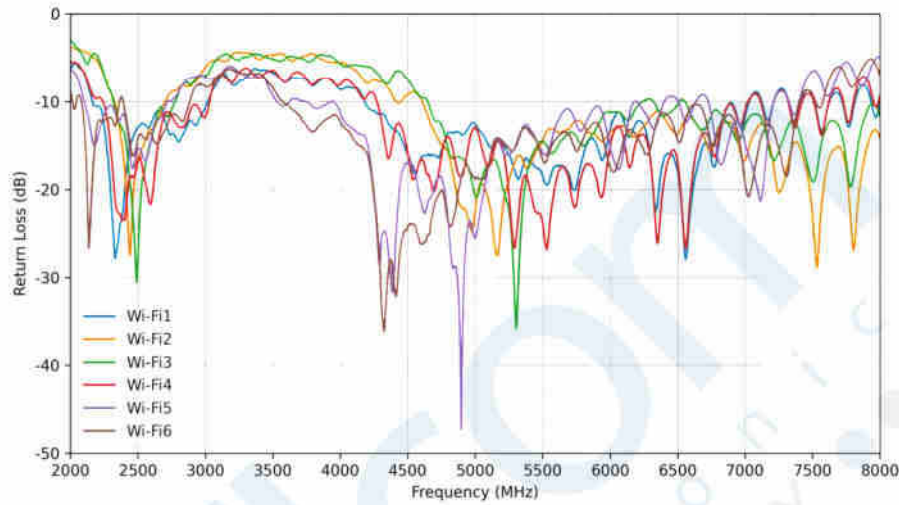

6.15 Wi-Fi - VSWR

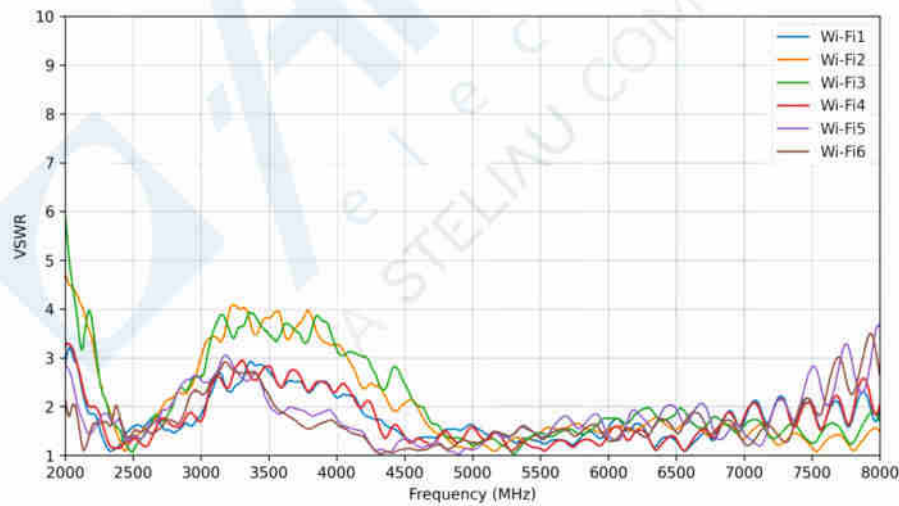

8.113 Wi-Fi6 Patterns at 2450 MHz

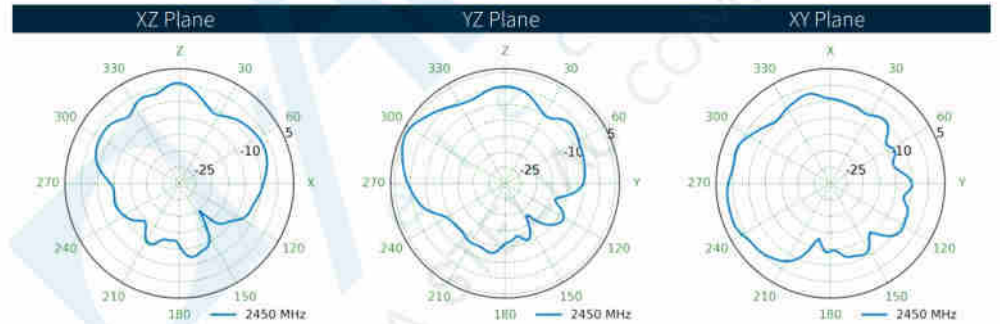
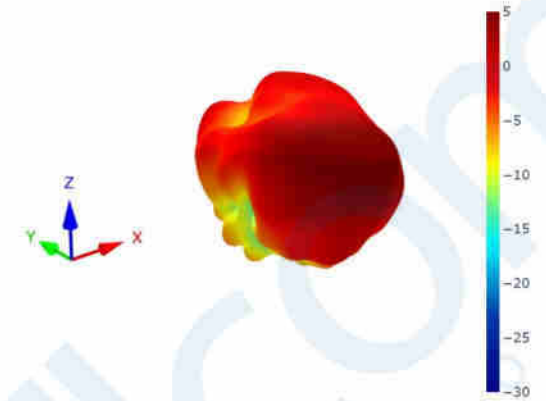

8.112 Wi-Fi5 Patterns at 2450 MHz

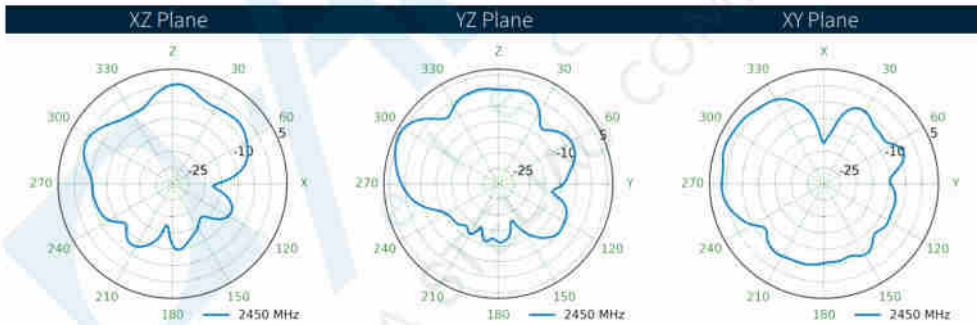
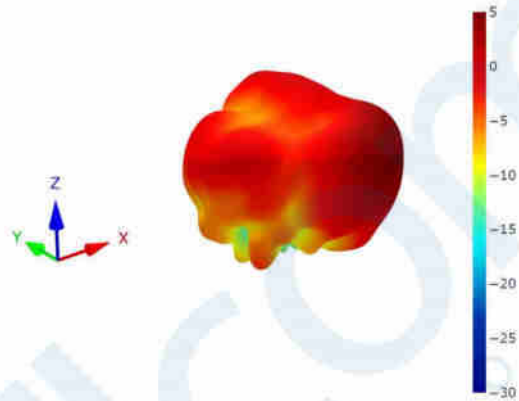

6.16 Wi-Fi - Isolation

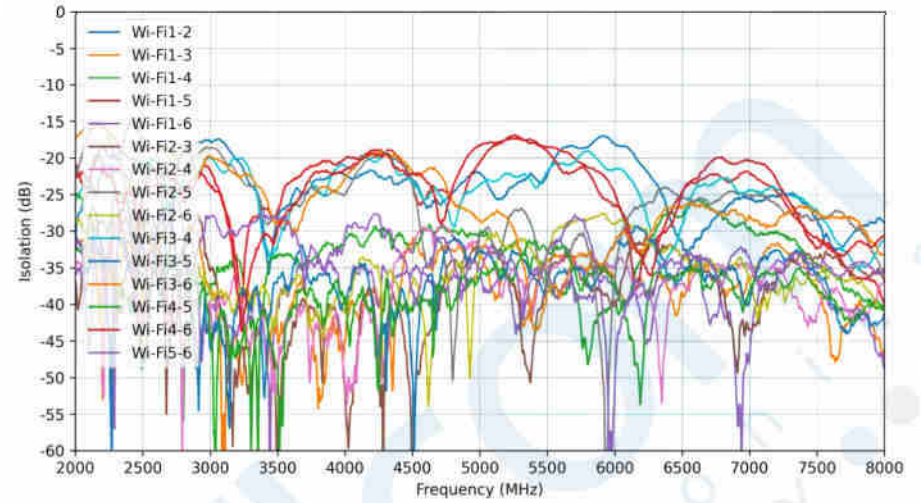

6.17 Wi-Fi - Efficiency

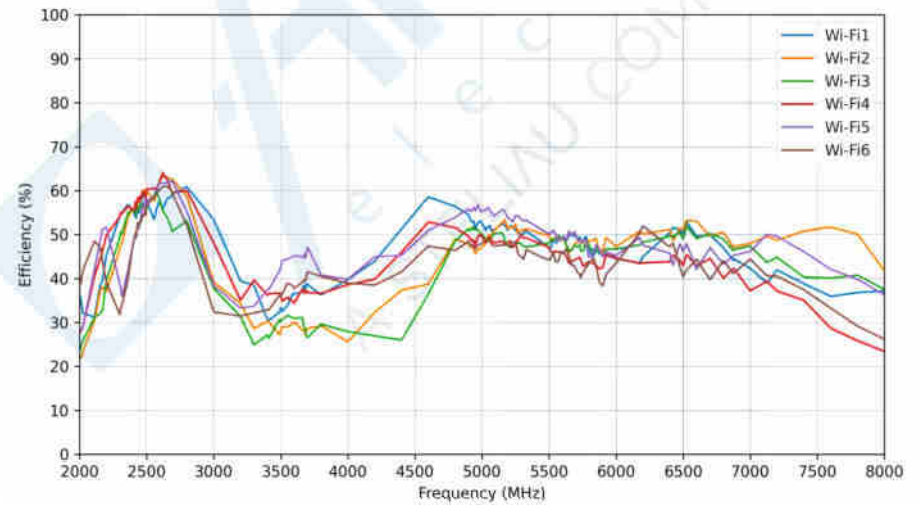

6.18 Wi-Fi - Average Gain

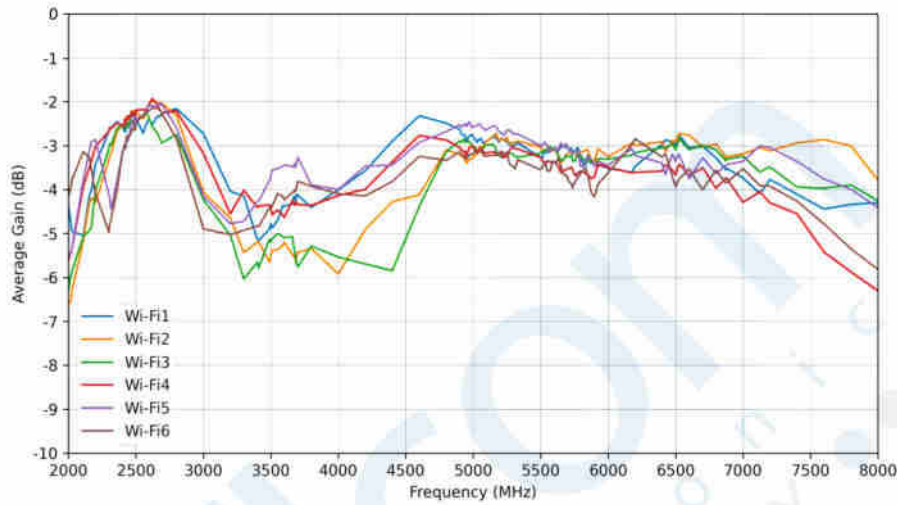

8.111 Wi-Fi4 Patterns at 2450 MHz

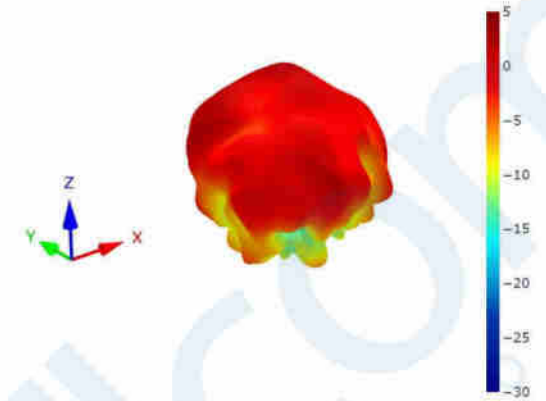

6.19 Wi-Fi - Peak Gain

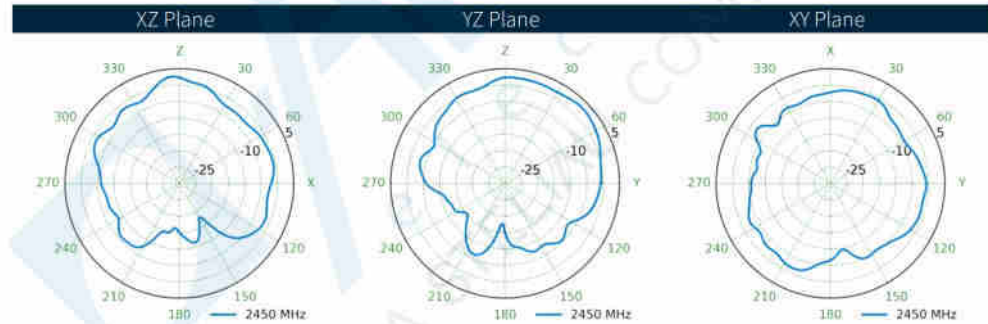
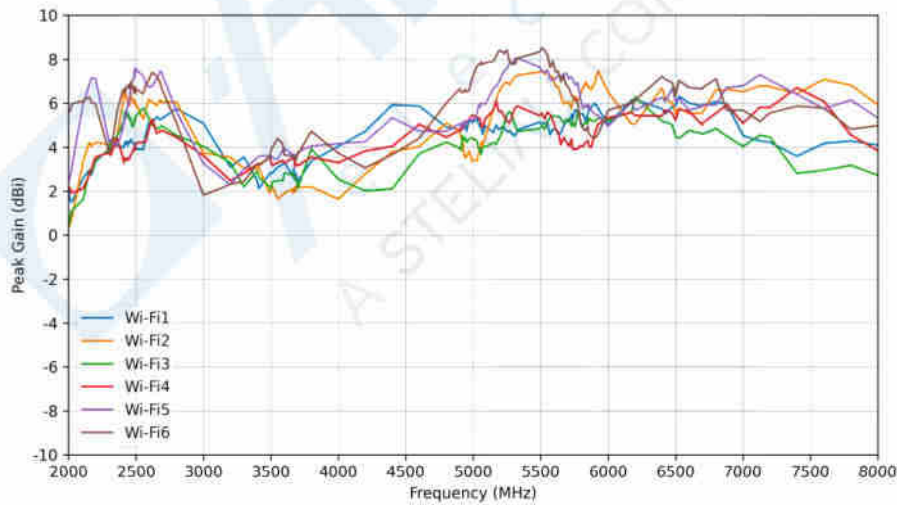

8.110 Wi-Fi3 Patterns at 2450 MHz

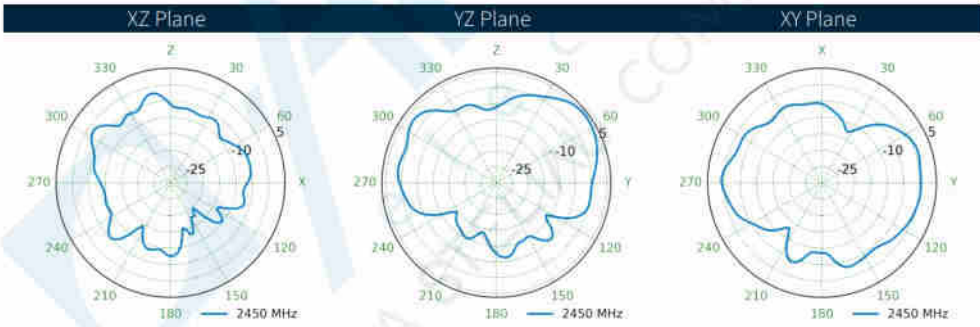
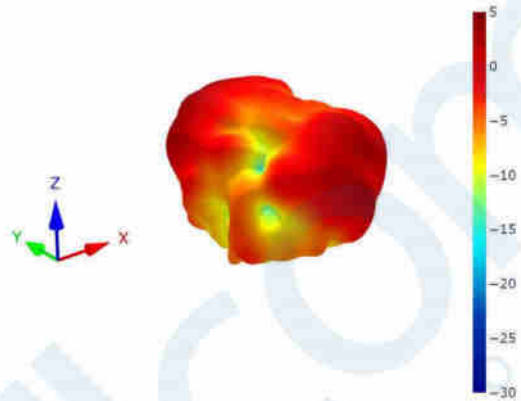

6.20 LMR

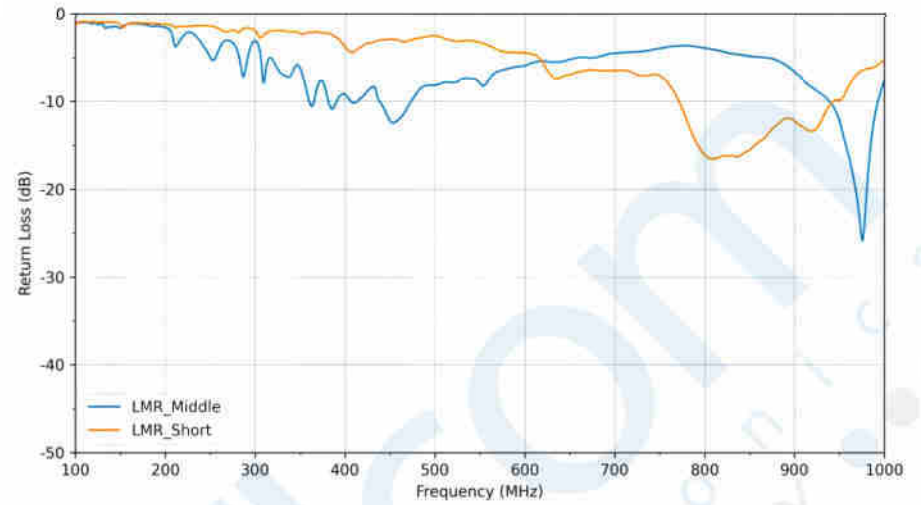

7. Active Antenna Characteristics

7. Block Diagram

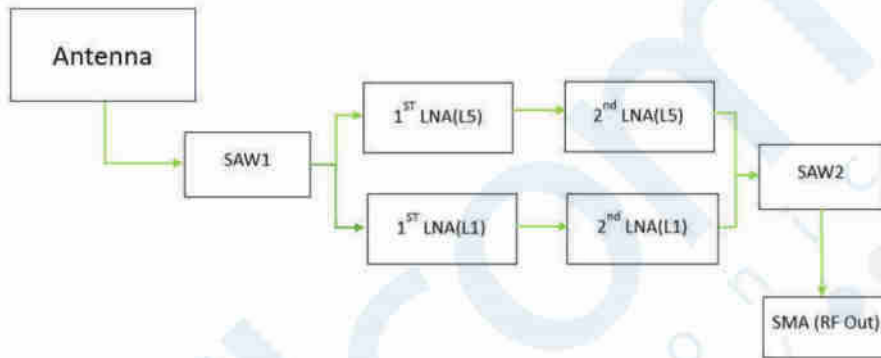

7. Noise Figure – Low-Band

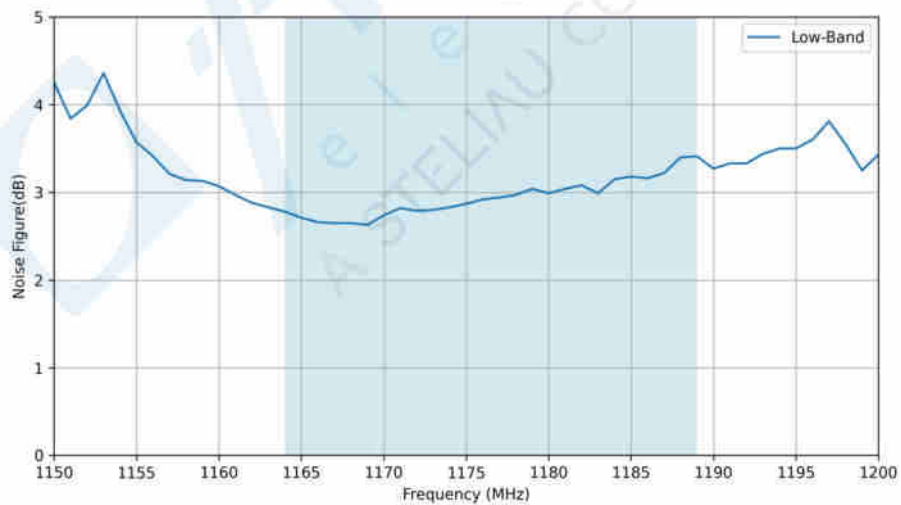

8.109 Wi-Fi2 Patterns at 2450 MHz

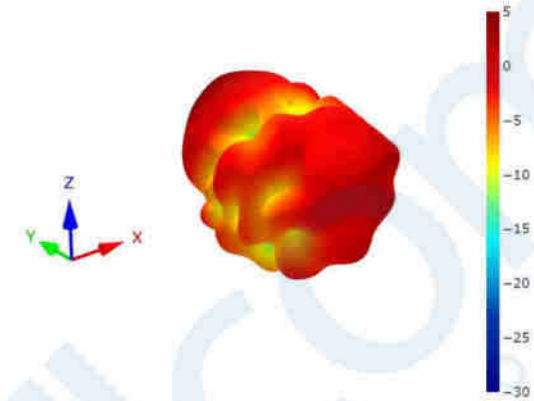

XZ Plane

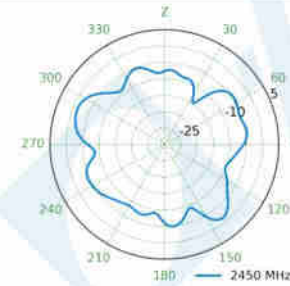

YZ Plane

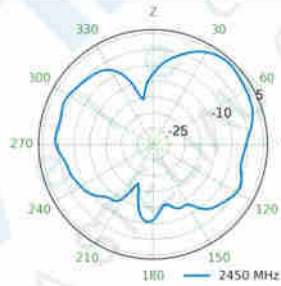

XY Plane

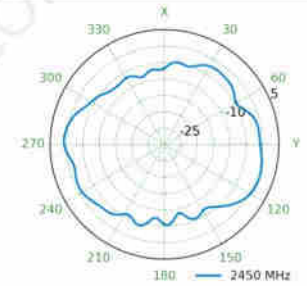

8.108 Wi-Fi1 Patterns at 2450 MHz

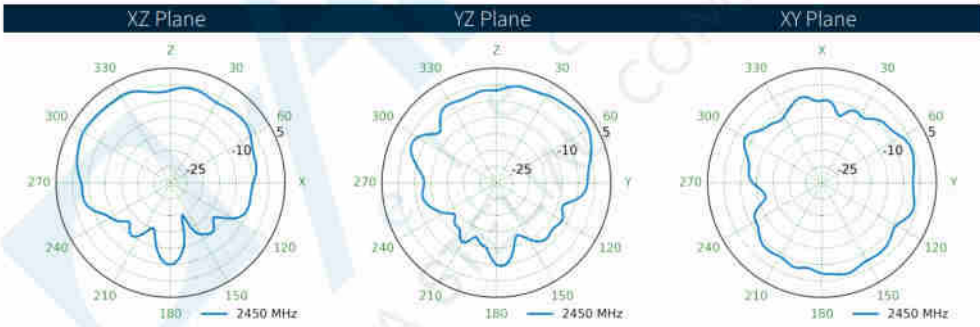
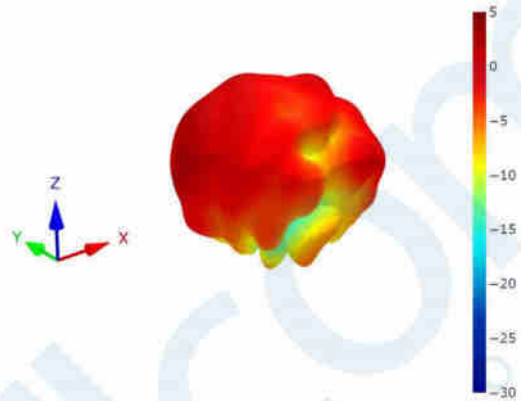

7.7 Noise Figure – High-Band

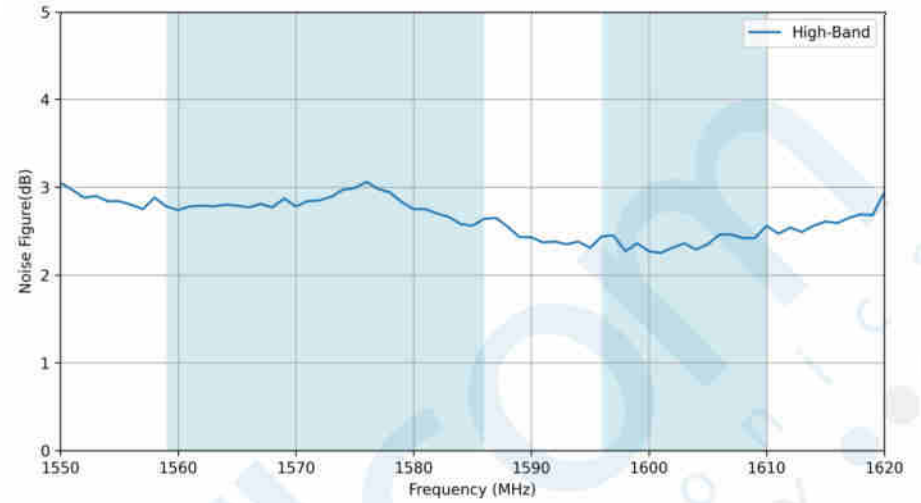

7.7 Gain – Low-Band

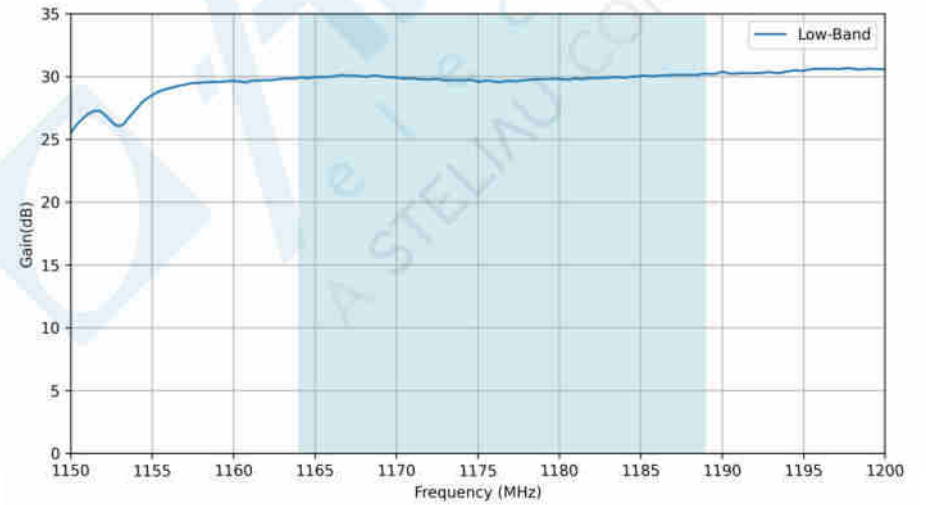

7. Gain – High-Band

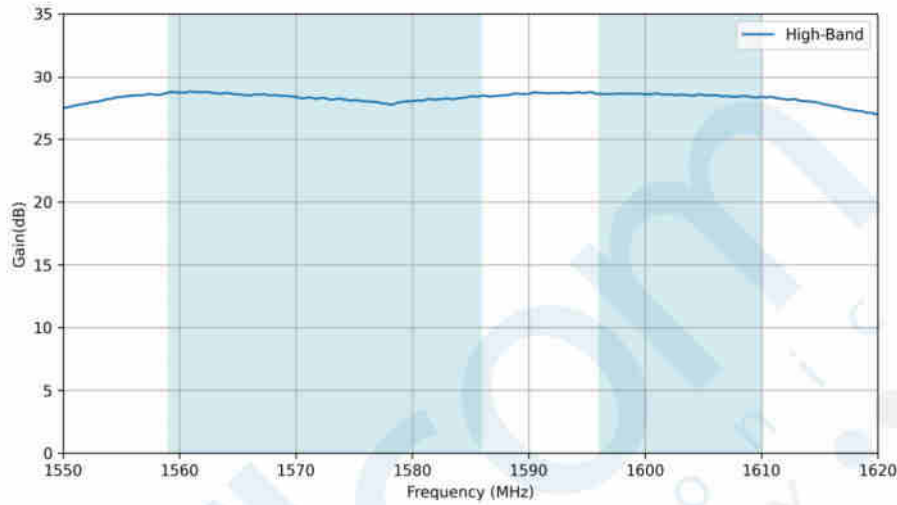

Gain – Wide-Band

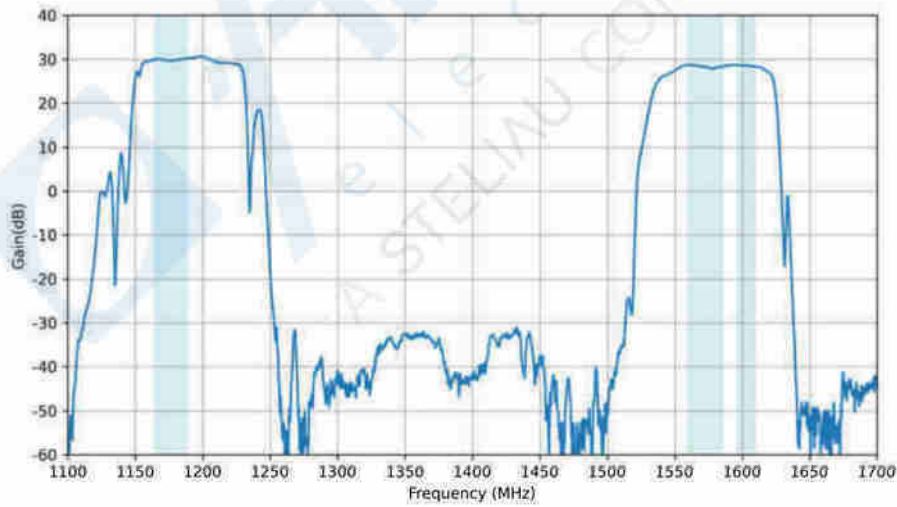

8.107 Cellular 8 Patterns at 5530 MHz

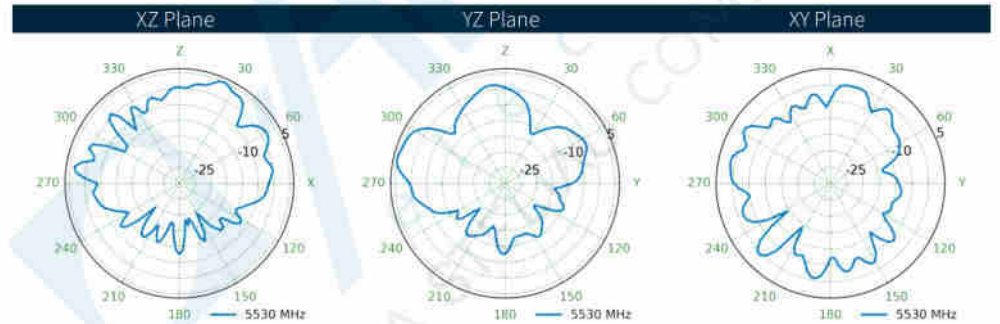
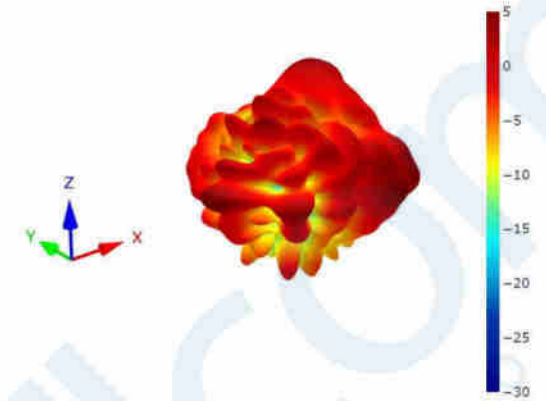

8.106 Cellular 7 Patterns at 5530 MHz

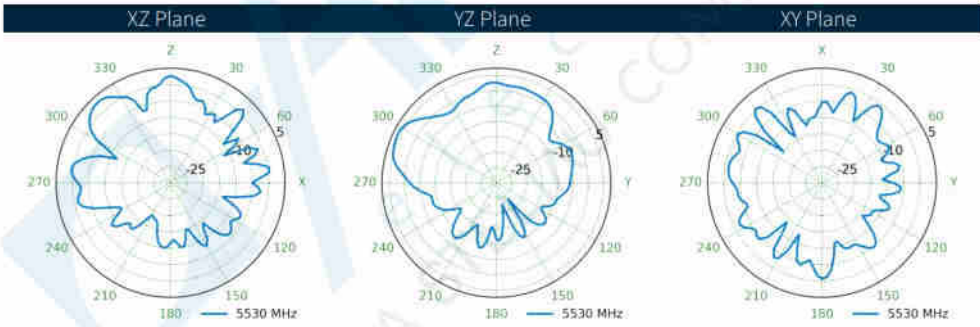
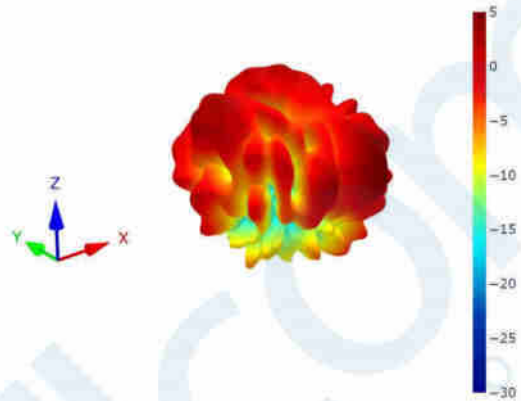

7.7 Out Of Band Rejection

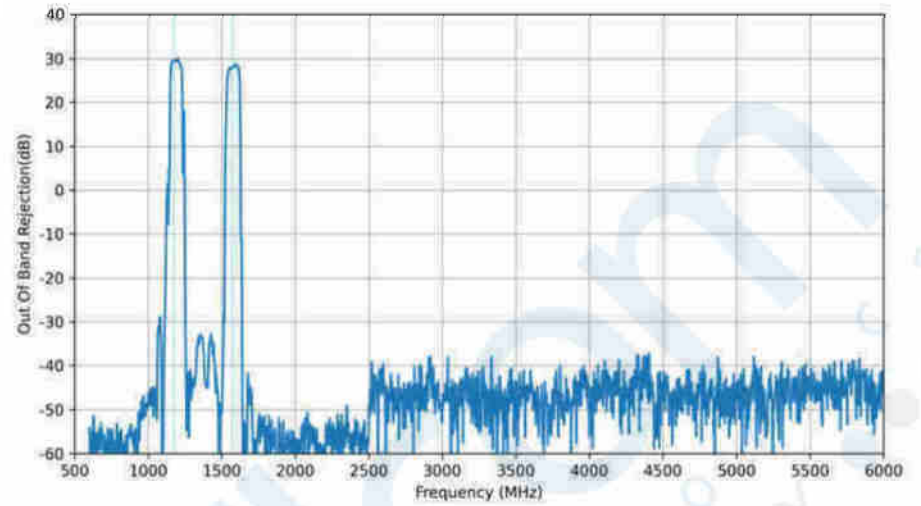

Group Delay - High-Band

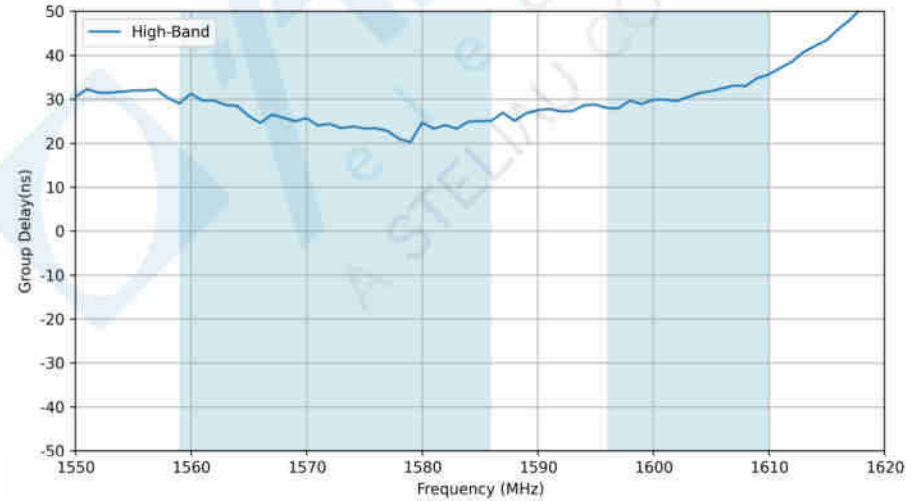

7.7 Group Delay - Low-Band

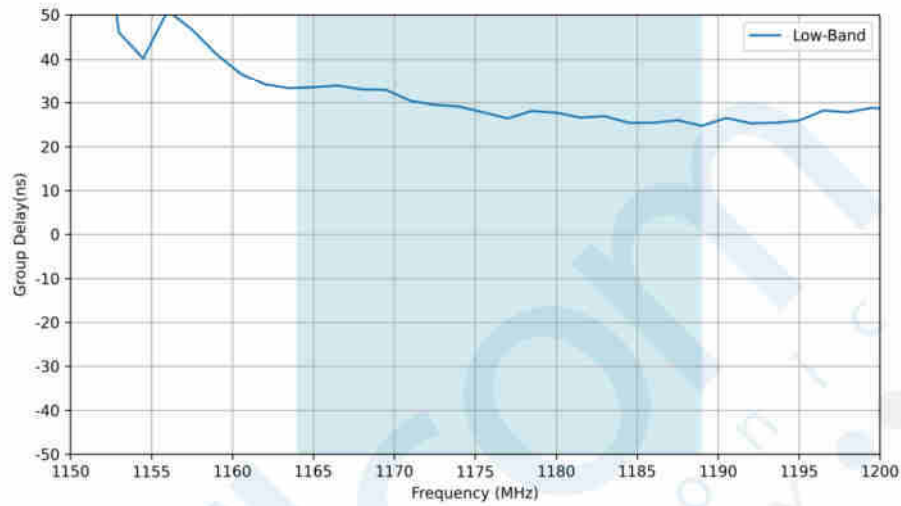

8.105 Cellular 6 Patterns at 5530 MHz

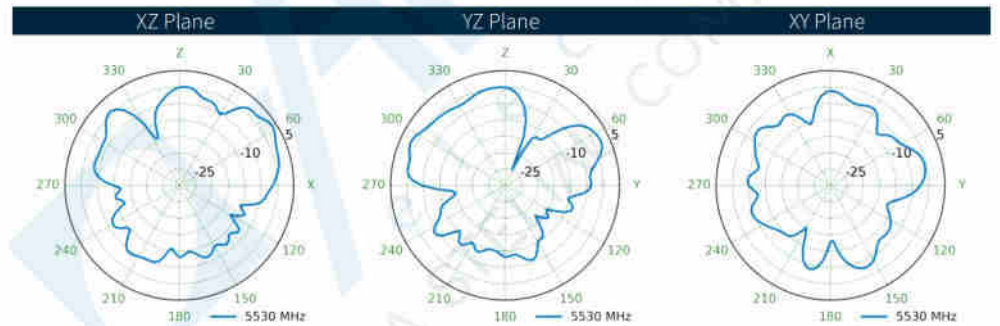
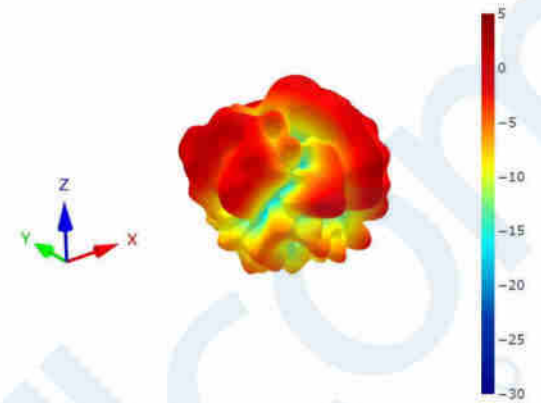

8.104 Cellular 5 Patterns at 5530 MHz

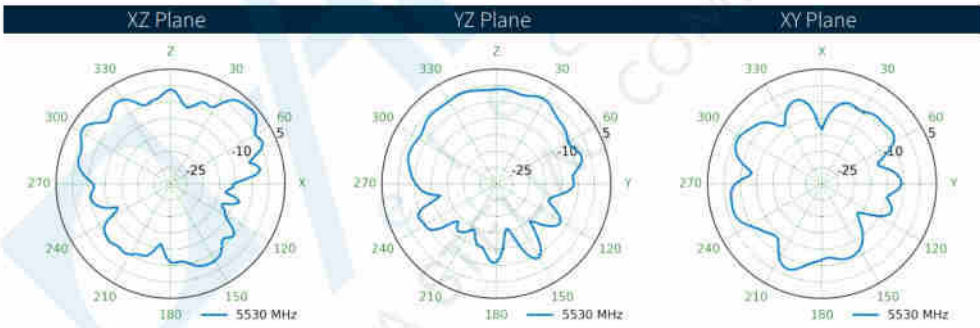
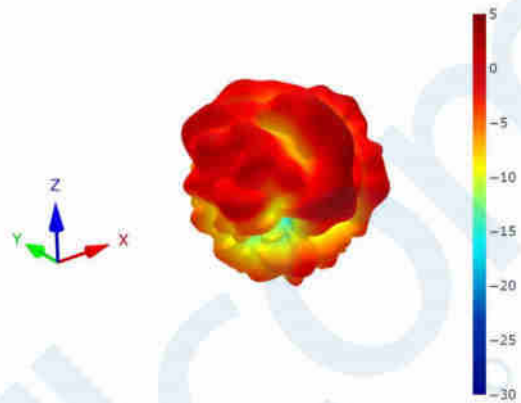

8. Radiation Patterns

8.1 Test Setup

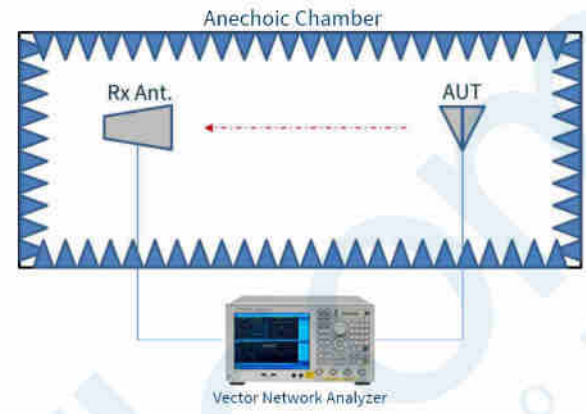

Chamber Test Set-up

8.2 GNSS Patterns at 1176 MHz

8.103 Cellular 4 Patterns at 5530 MHz

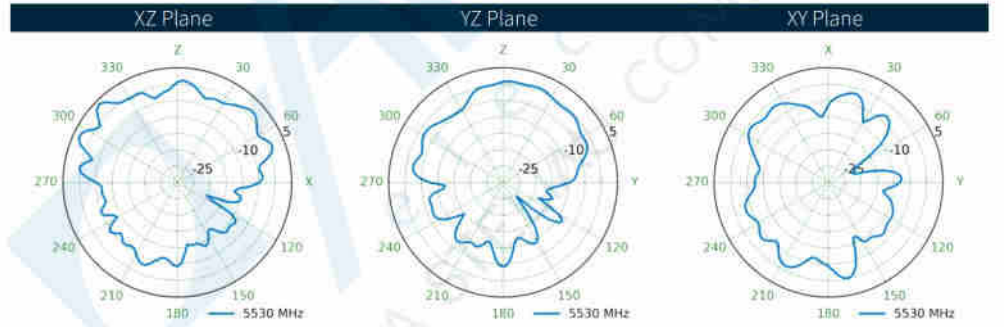
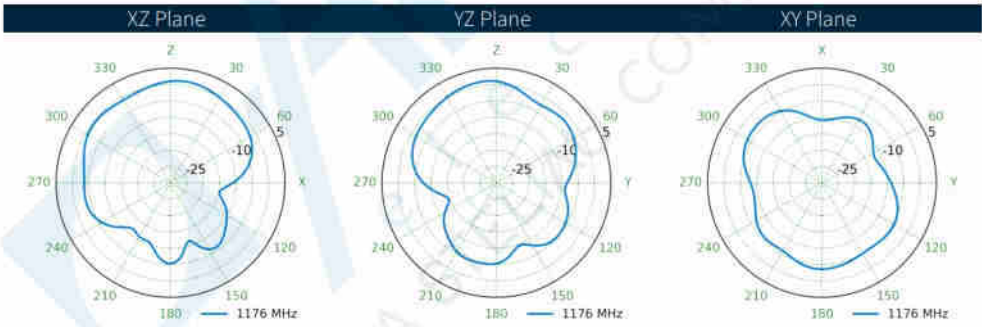
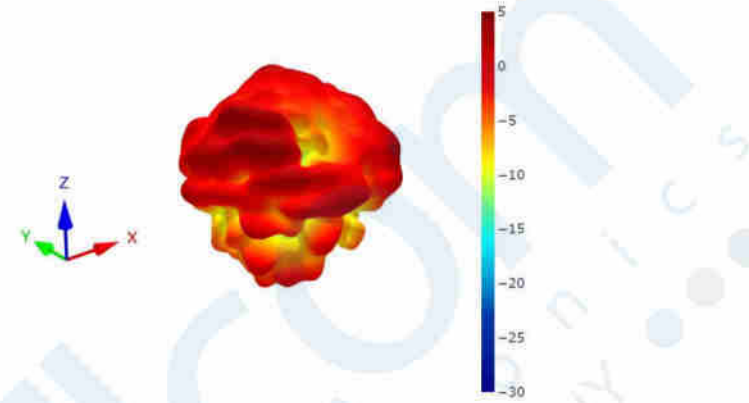
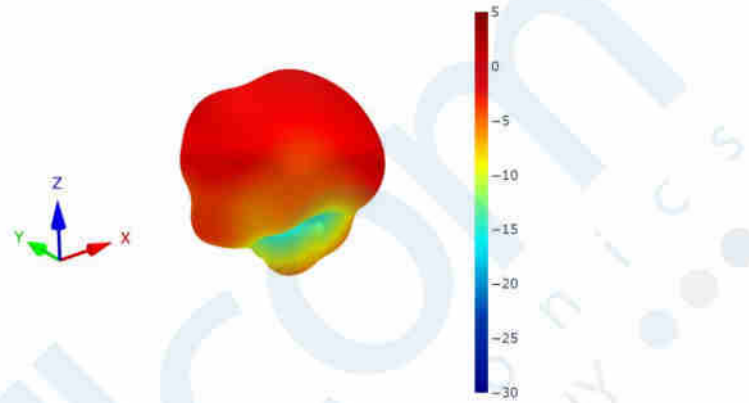

8.102 Cellular 3 Patterns at 5530 MHz

8.. GNSS Patterns at 1575 MHz

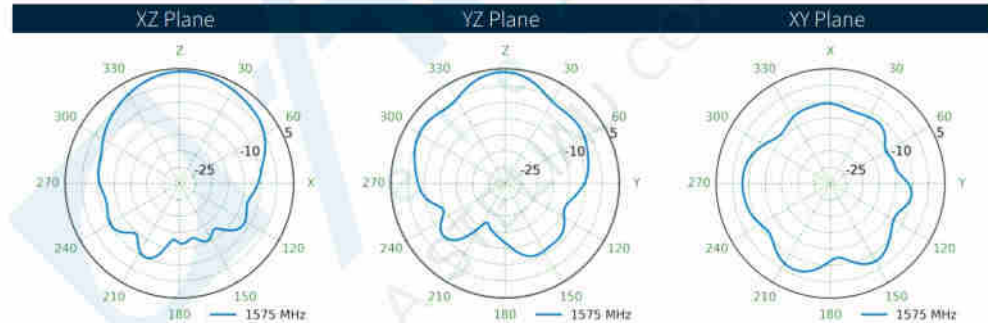
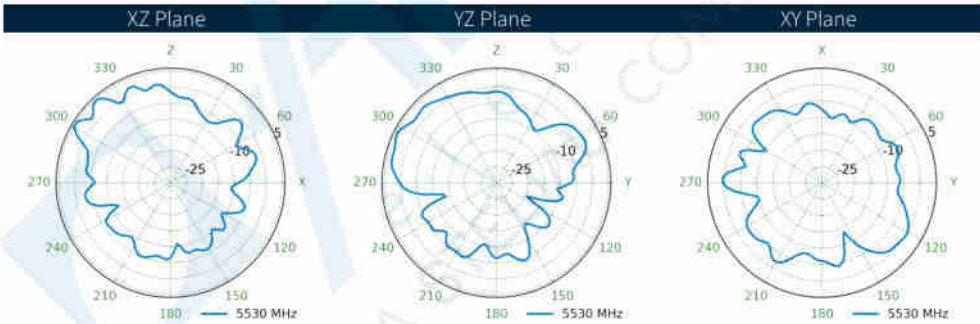
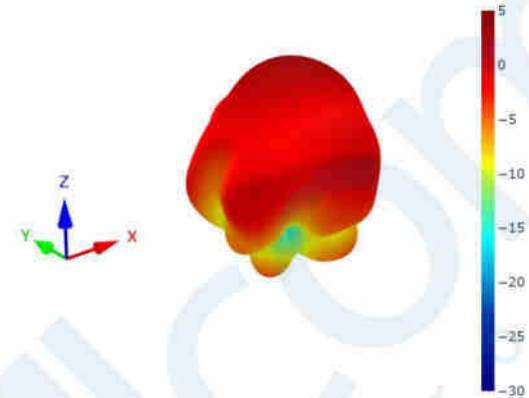
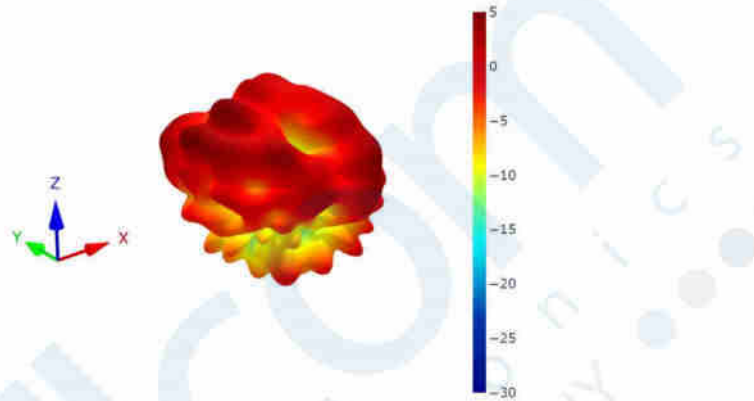

8.4 Cellular 1 Patterns at 652 MHz

8.101 Cellular 2 Patterns at 5530 MHz

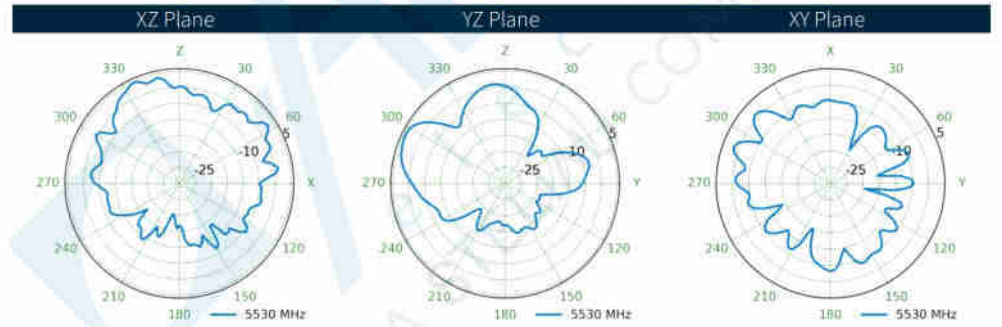
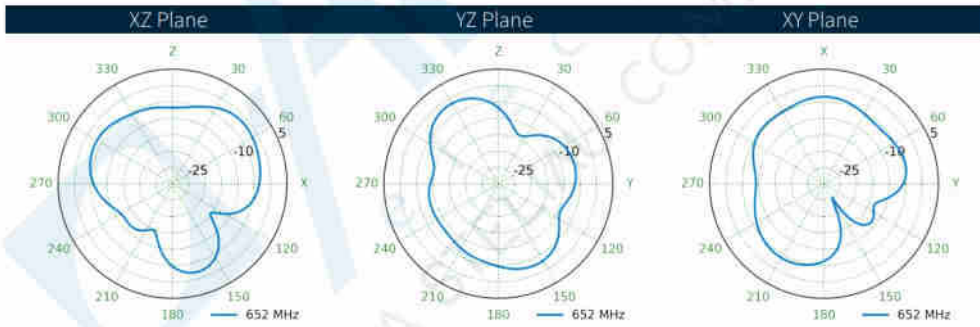
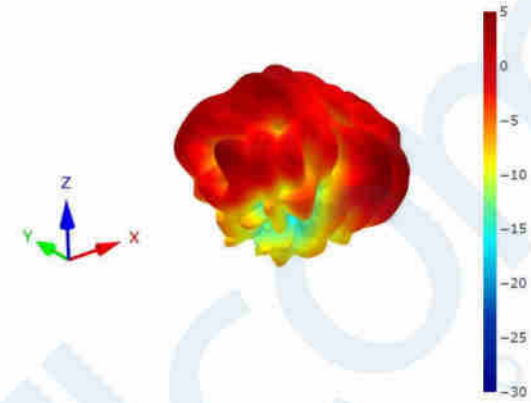
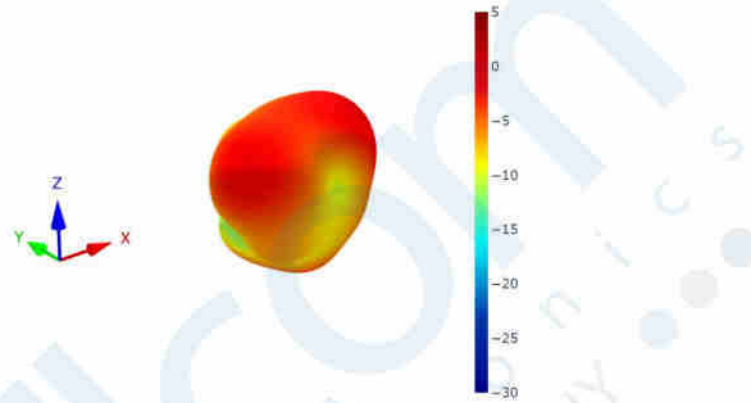

8.100 Cellular 1 Patterns at 5530 MHz

8.1 Cellular 2 Patterns at 652 MHz

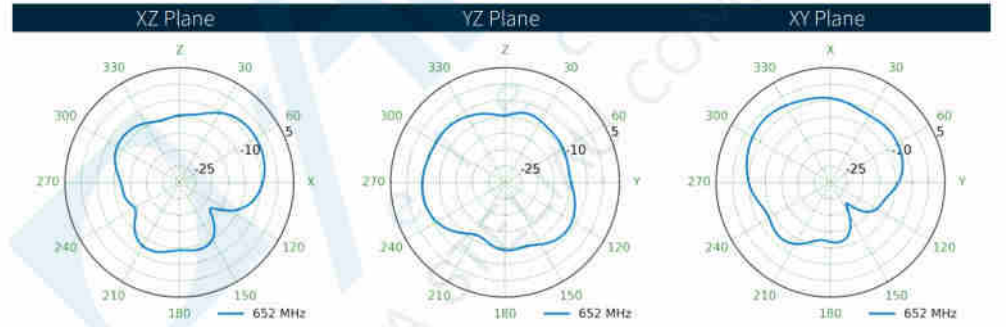
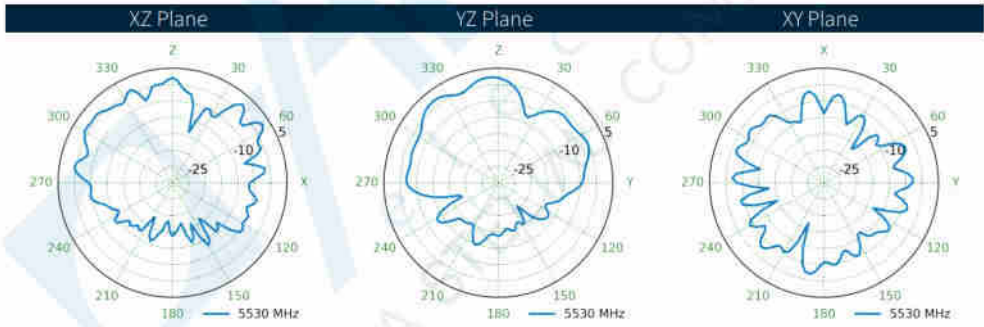
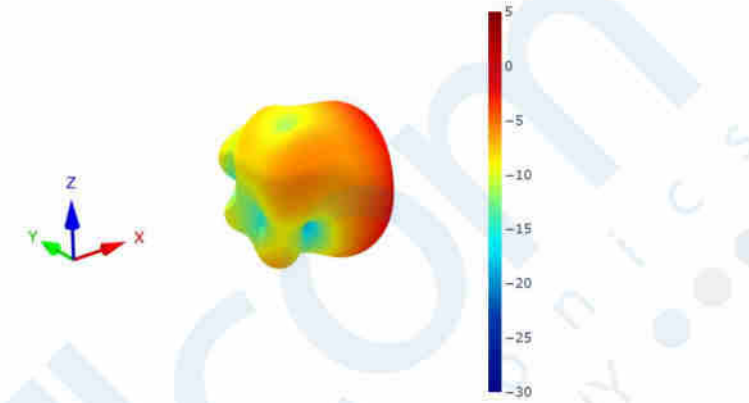
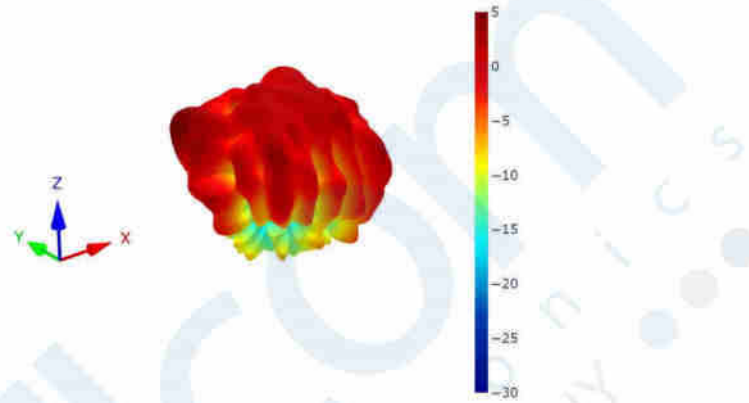

8.8 Cellular 3 Patterns at 652 MHz

8.99 Cellular 8 Patterns at 4800 MHz

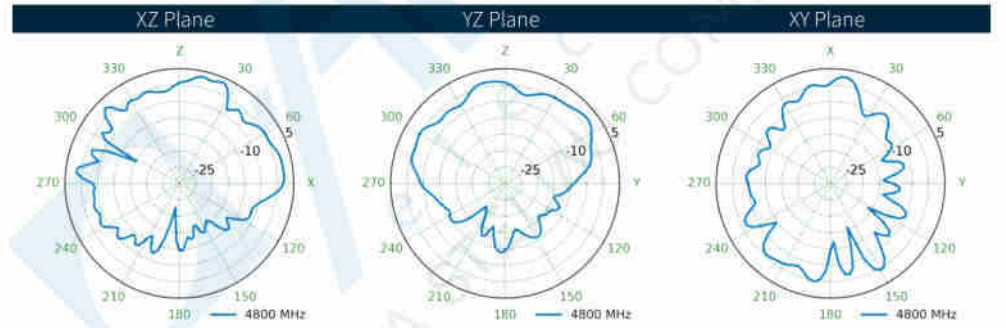
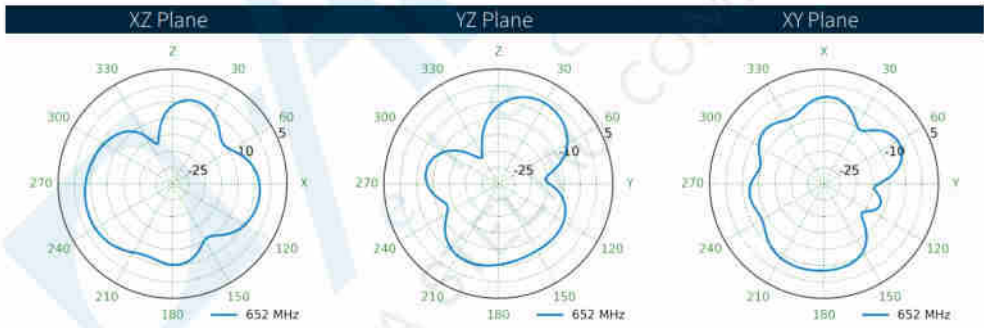
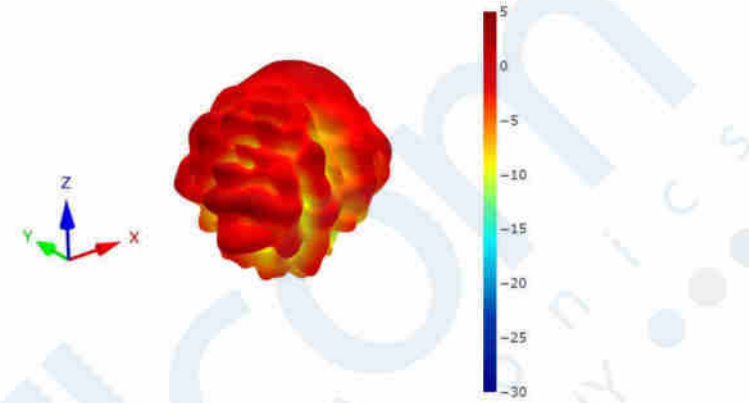
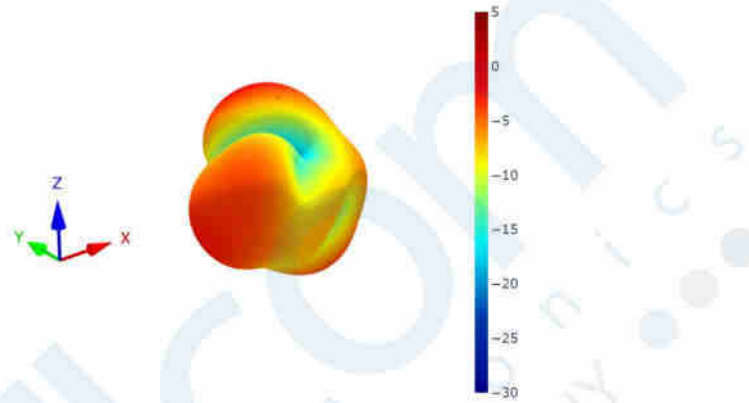

8.98 Cellular 7 Patterns at 4800 MHz

8.7 Cellular 4 Patterns at 652 MHz

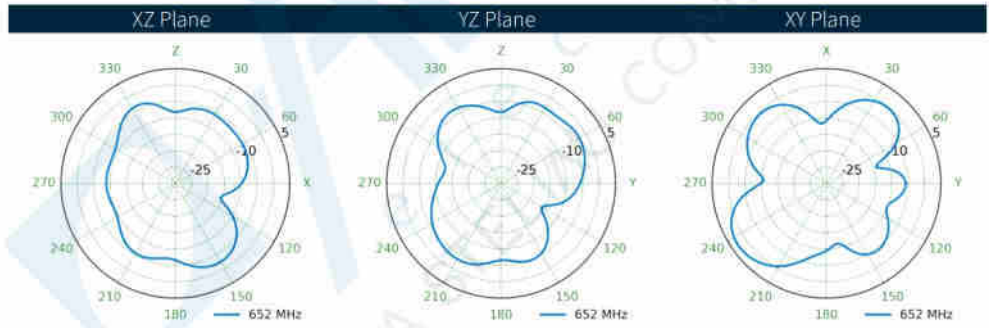
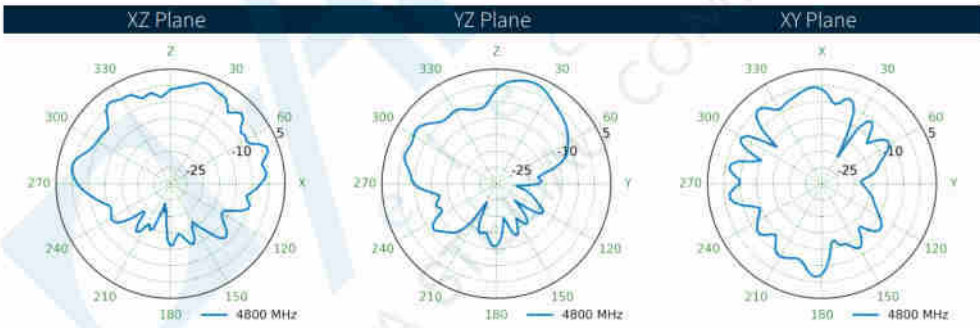
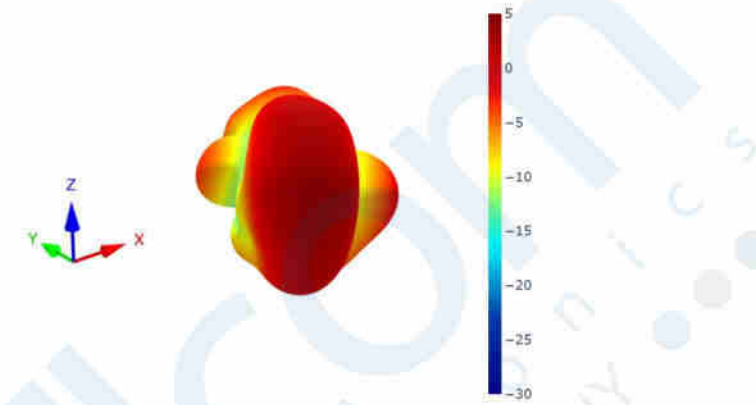
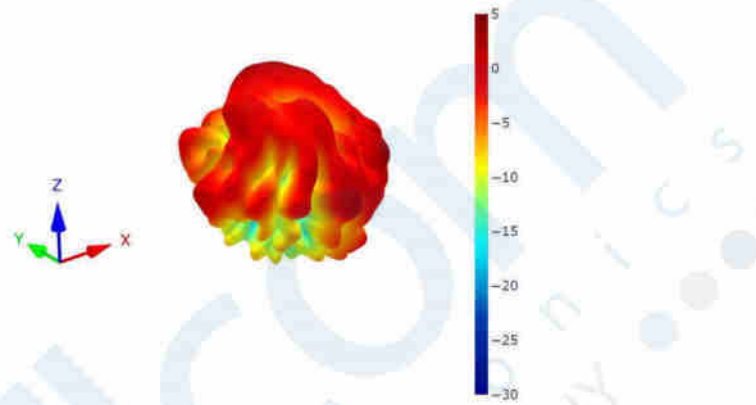

8.8 Cellular 5 Patterns at 652 MHz

8.97 Cellular 6 Patterns at 4800 MHz

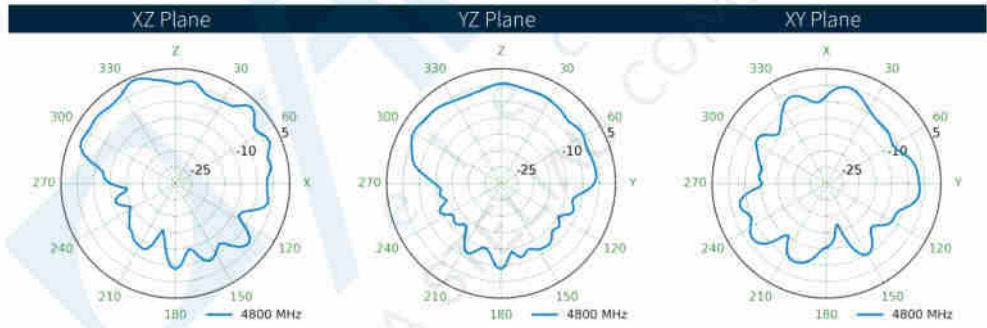
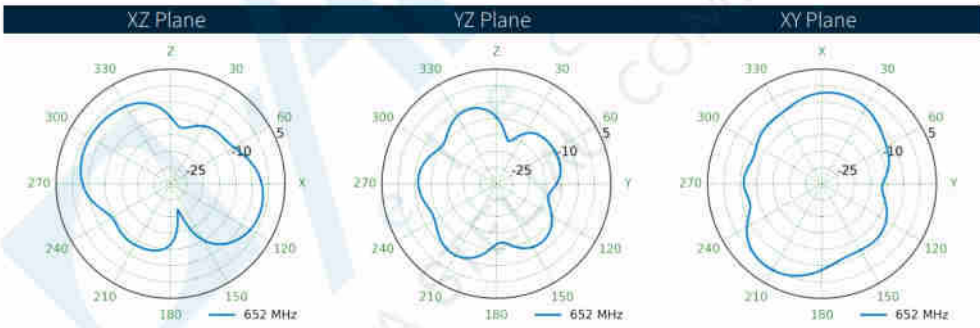
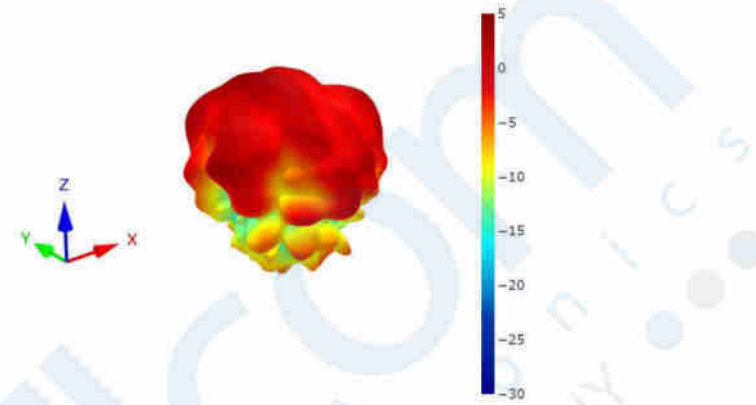
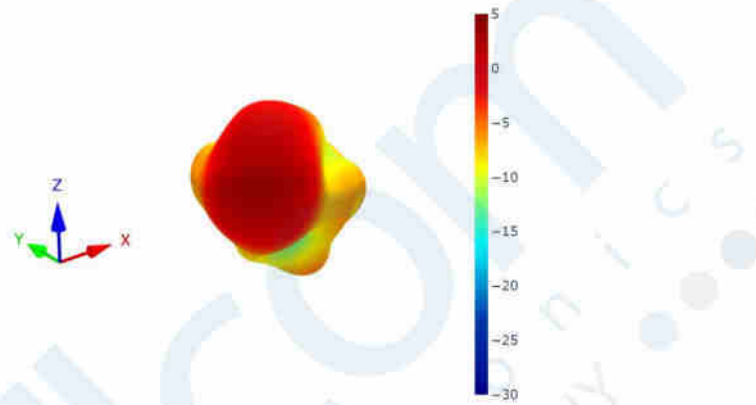

8.96 Cellular 5 Patterns at 4800 MHz

8.9 Cellular 6 Patterns at 652 MHz

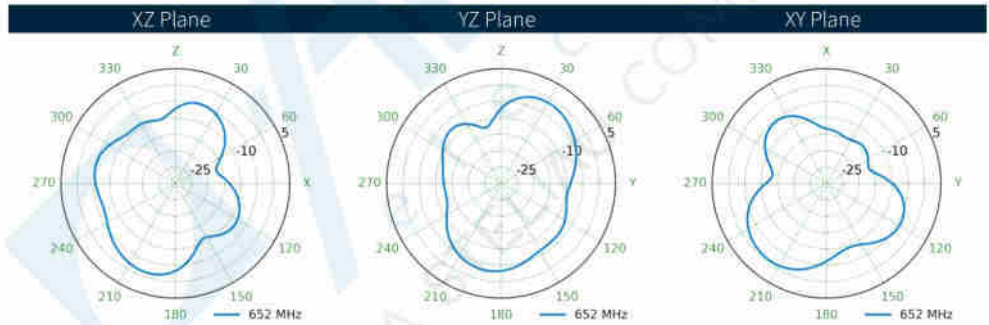
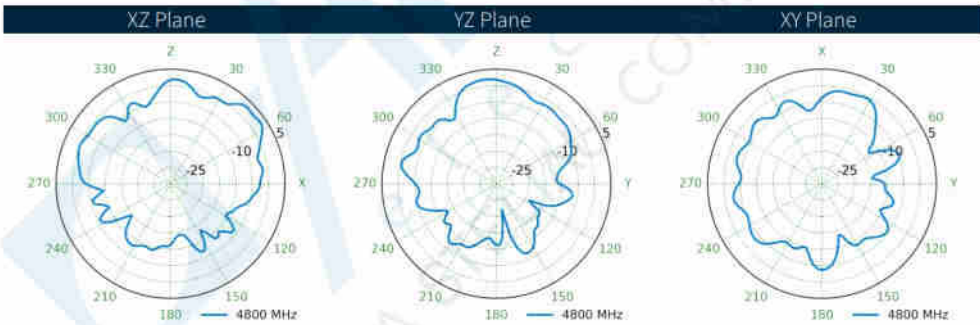
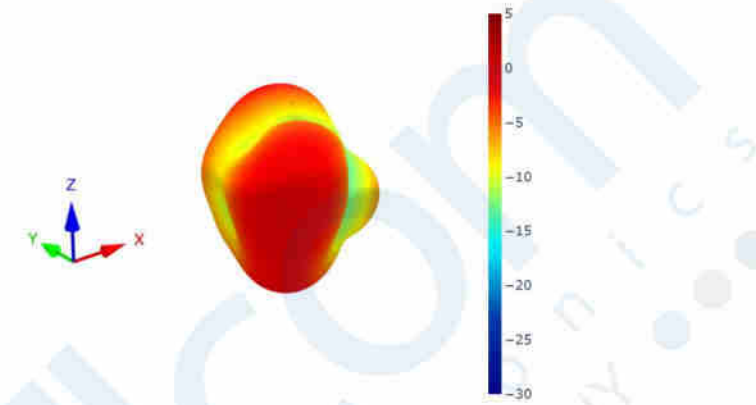
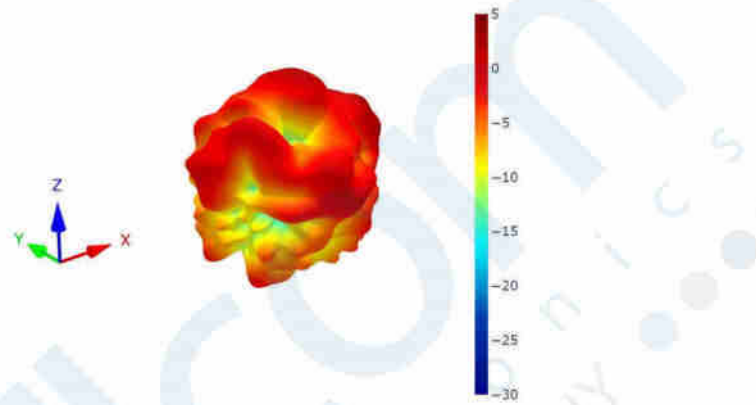

8.10 Cellular 7 Patterns at 652 MHz

8.95 Cellular 4 Patterns at 4800 MHz

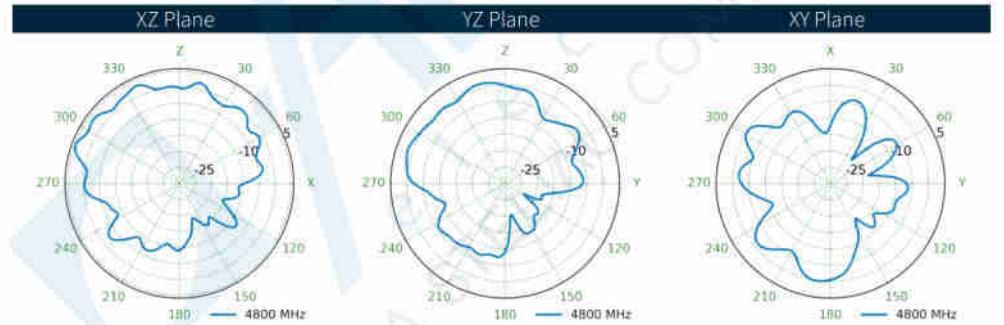
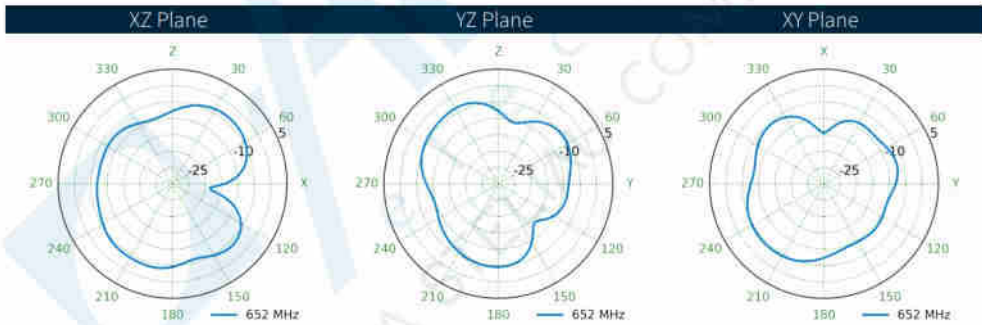
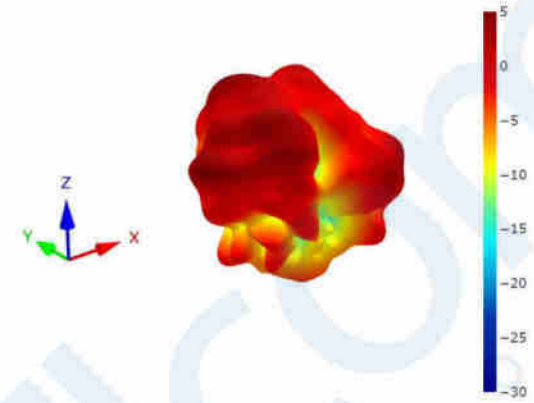
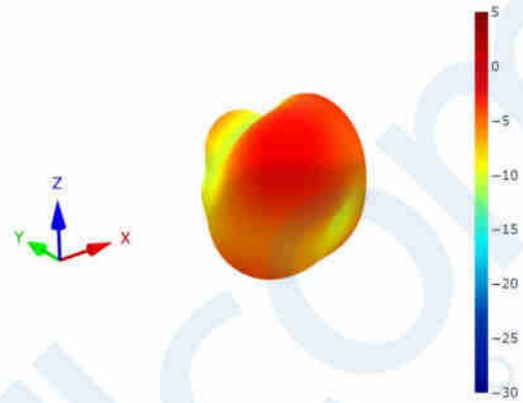

8.94 Cellular 3 Patterns at 4800 MHz

8.11 Cellular 8 Patterns at 652 MHz

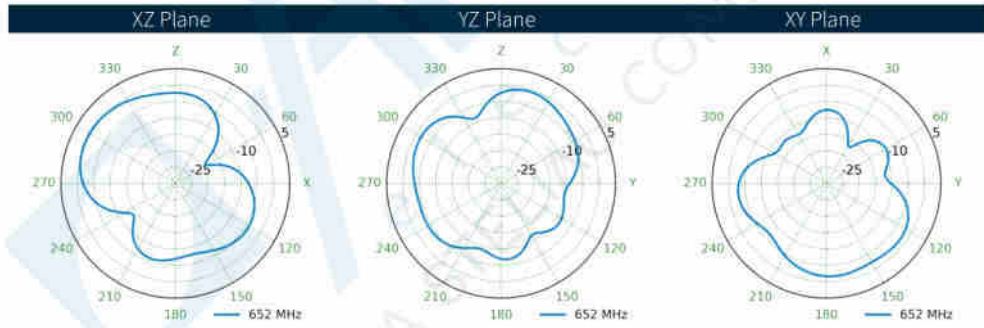
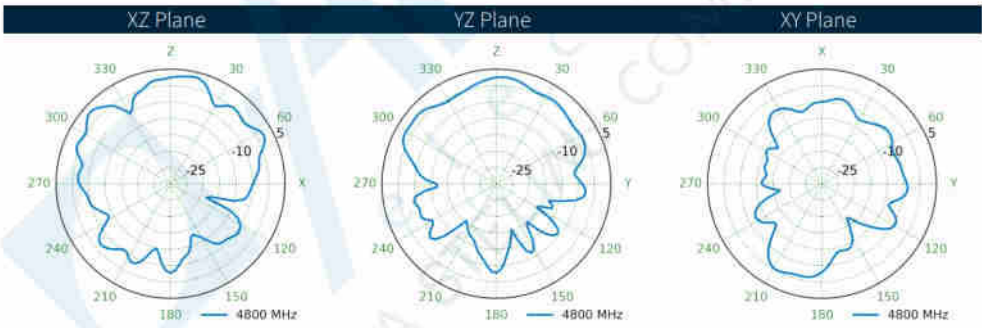
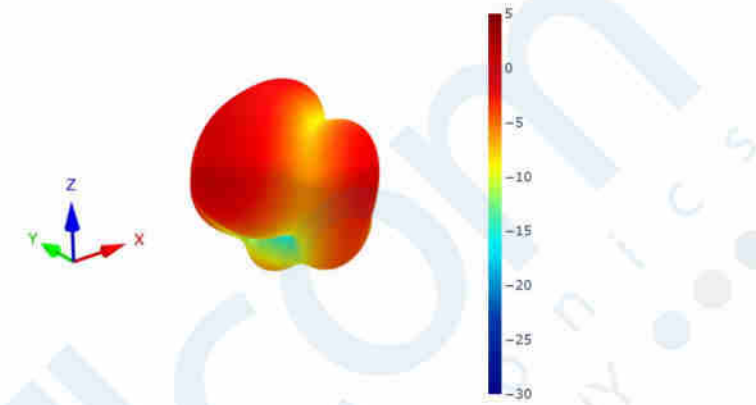
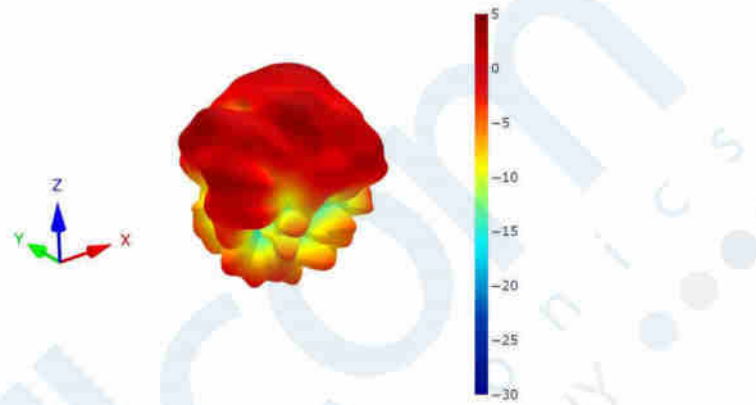

8.12 Cellular 1 Patterns at 751 MHz

8.93 Cellular 2 Patterns at 4800 MHz

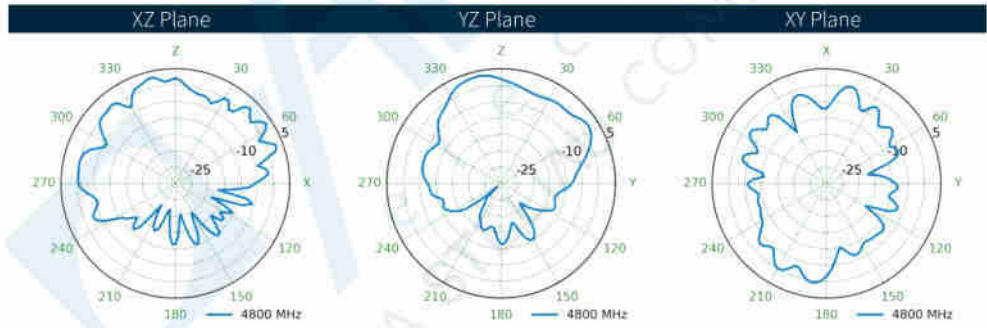
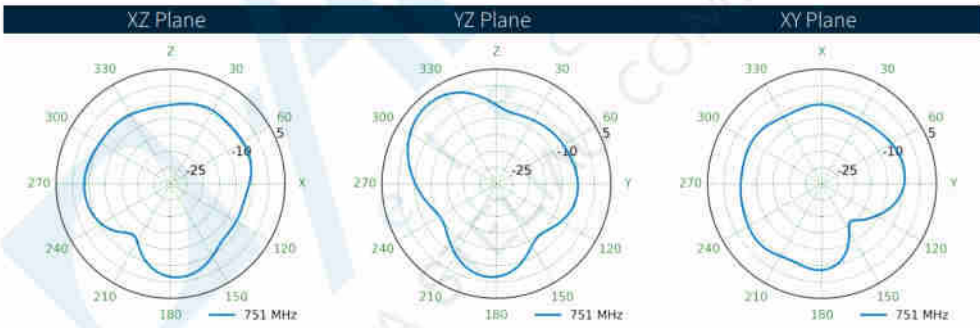
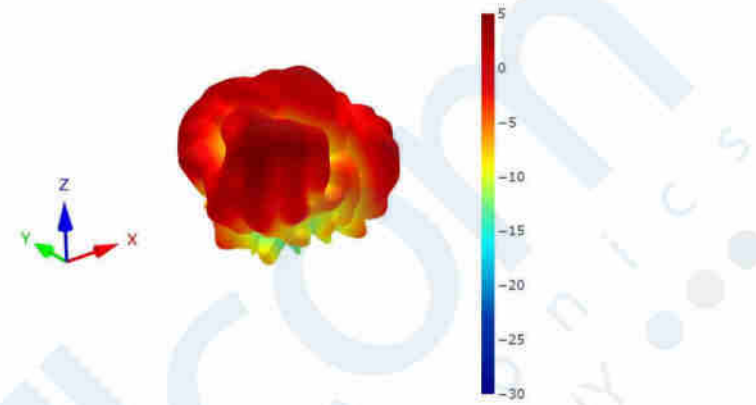
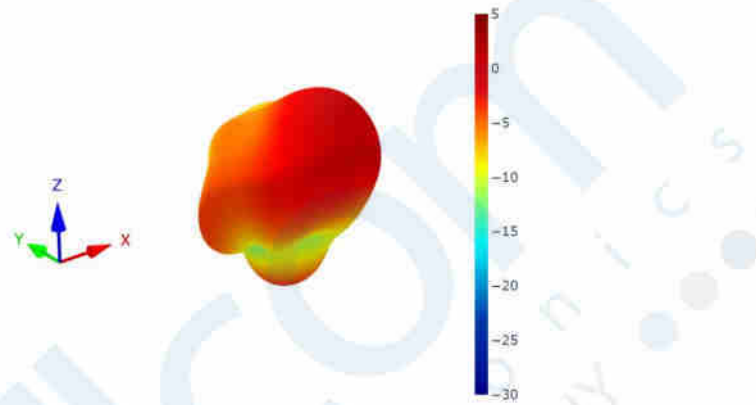

8.92 Cellular 1 Patterns at 4800 MHz

8.13 Cellular 2 Patterns at 751 MHz

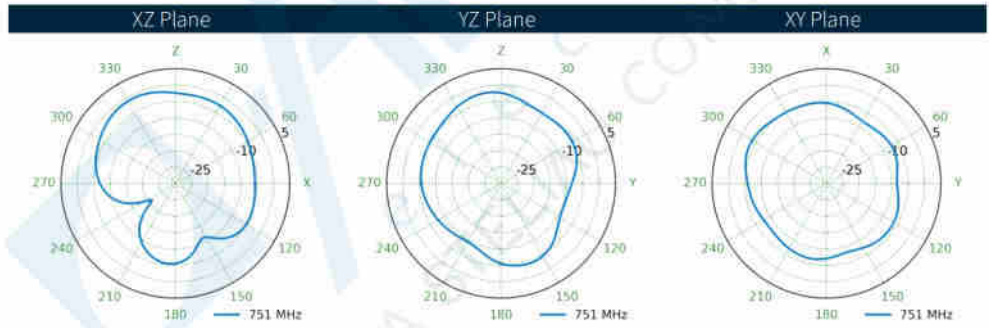
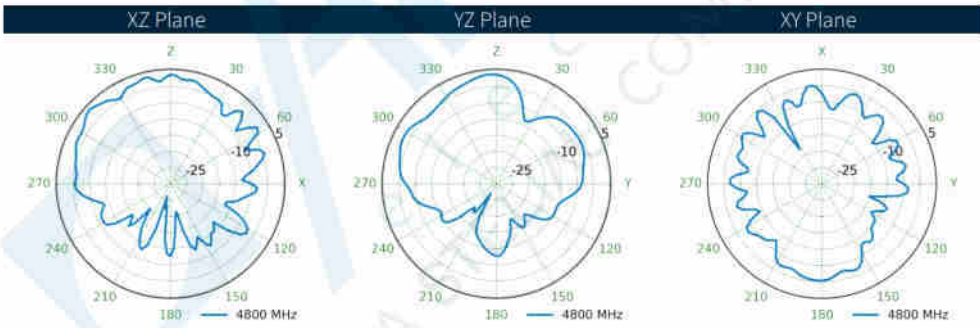
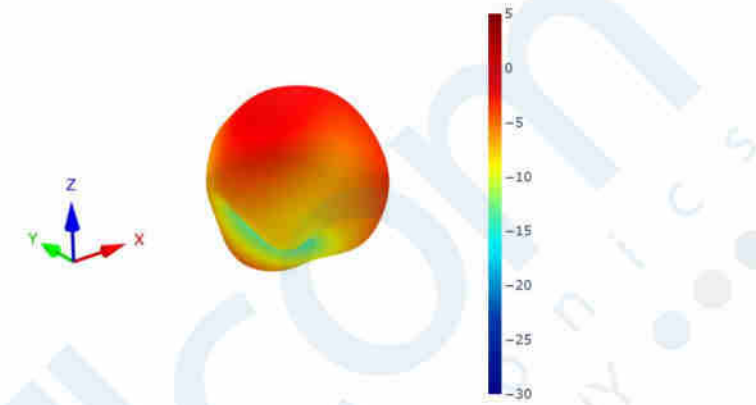
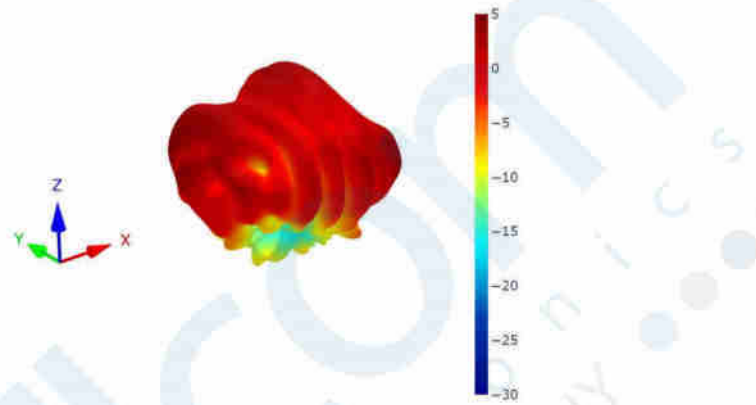

8.14 Cellular 3 Patterns at 751 MHz

8.91 Cellular 8 Patterns at 4600 MHz

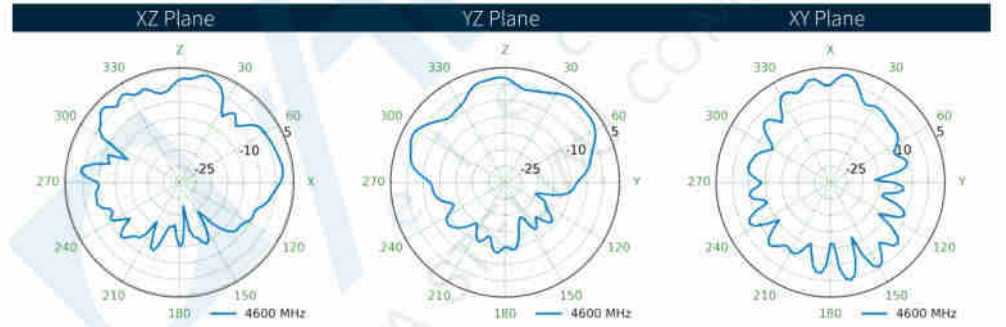
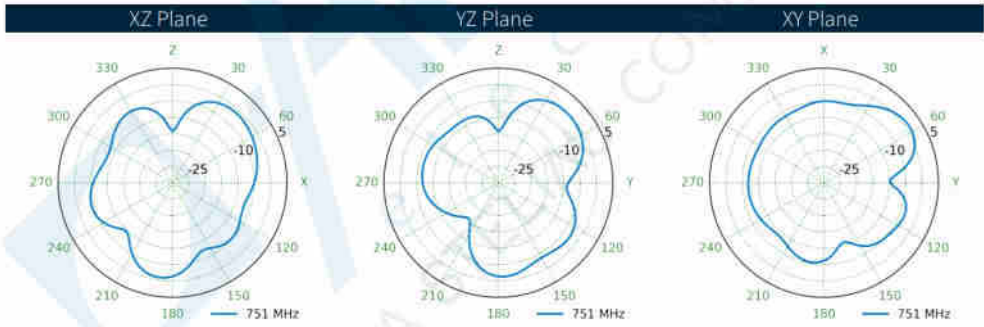
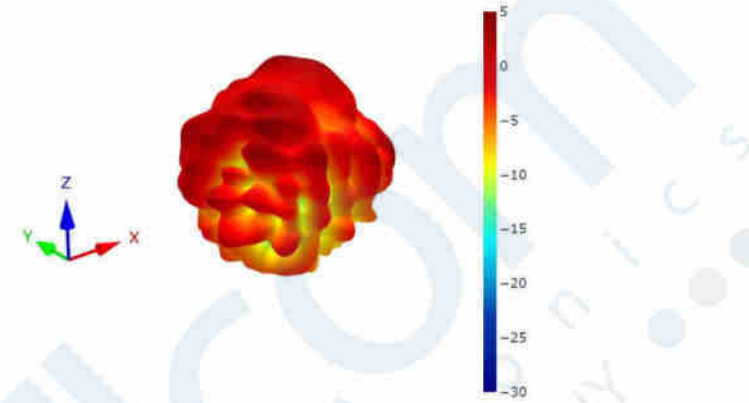
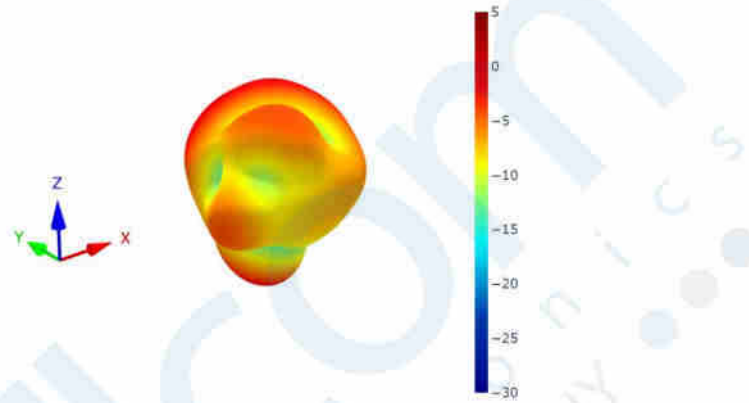

8.90 Cellular 7 Patterns at 4600 MHz

8.15 Cellular 4 Patterns at 751 MHz

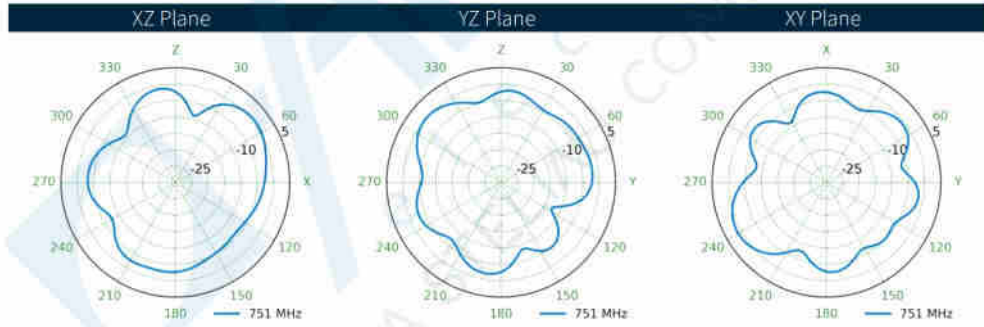
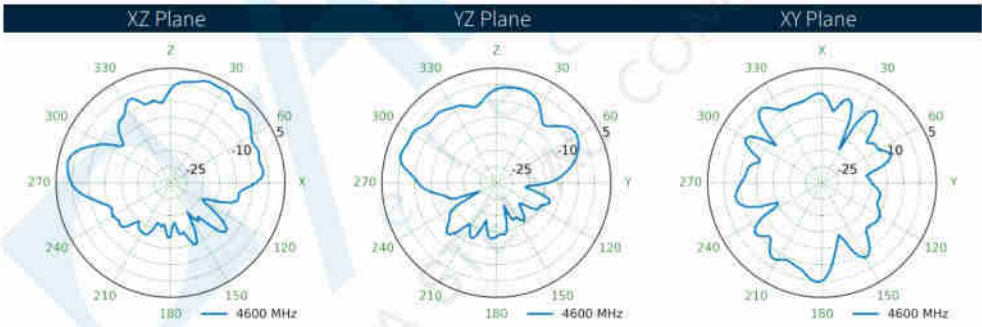
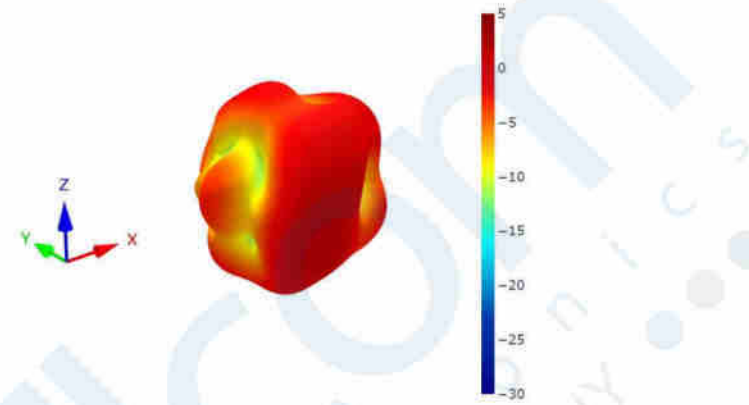
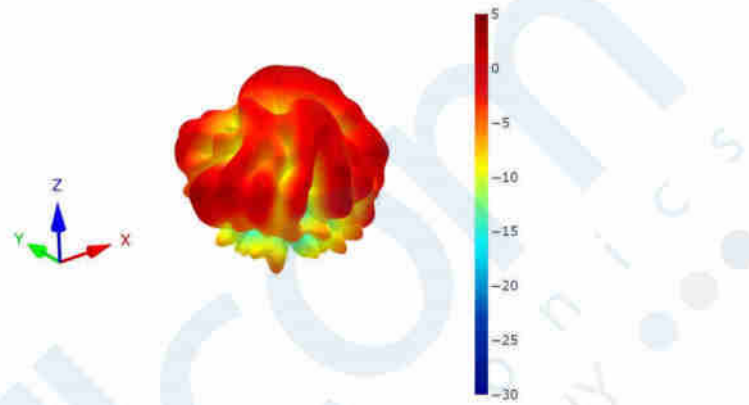

8.16 Cellular 5 Patterns at 751 MHz

8.89 Cellular 6 Patterns at 4600 MHz

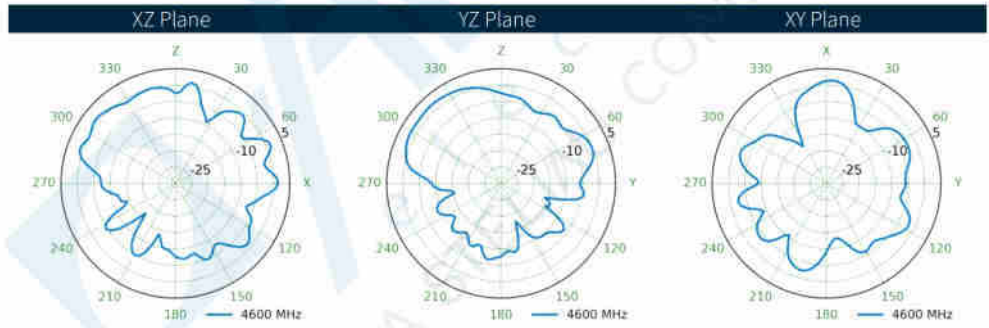
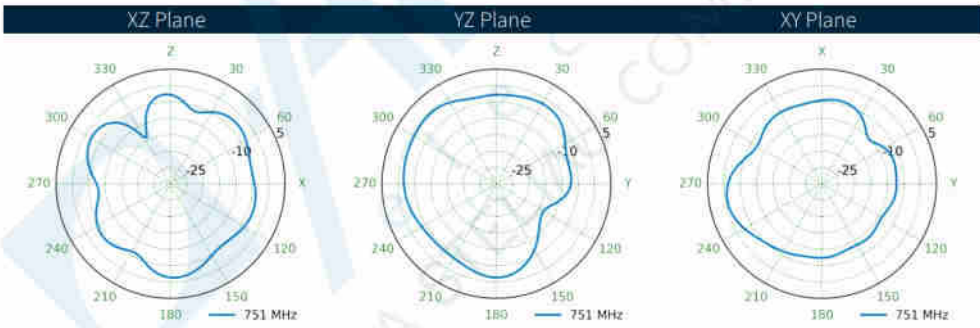
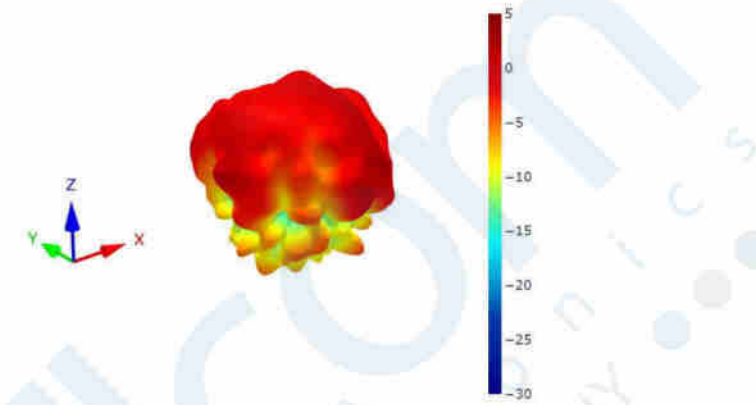
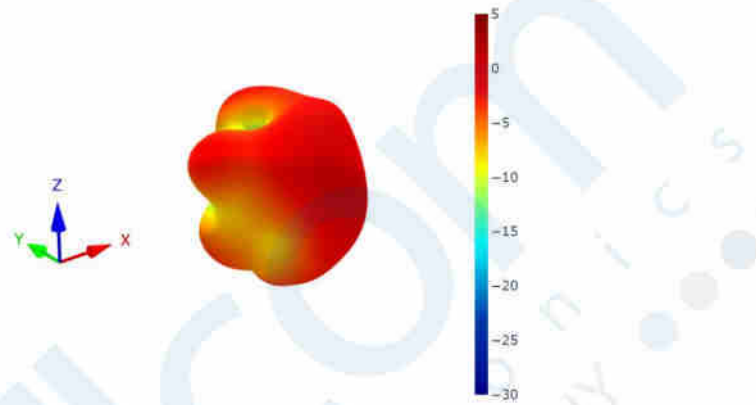

8.88 Cellular 5 Patterns at 4600 MHz

8.17 Cellular 6 Patterns at 751 MHz

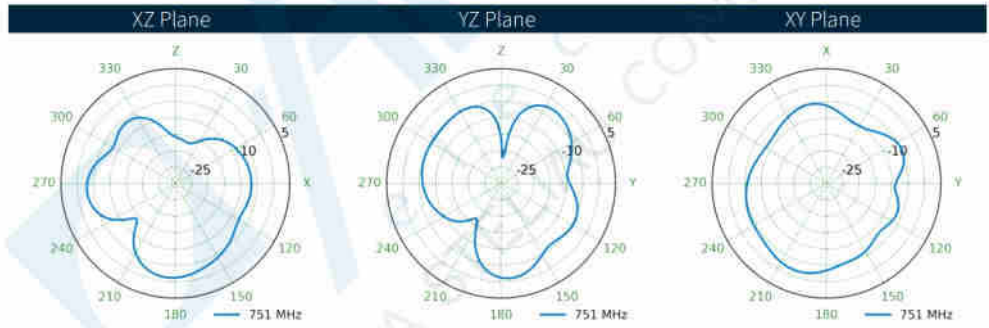
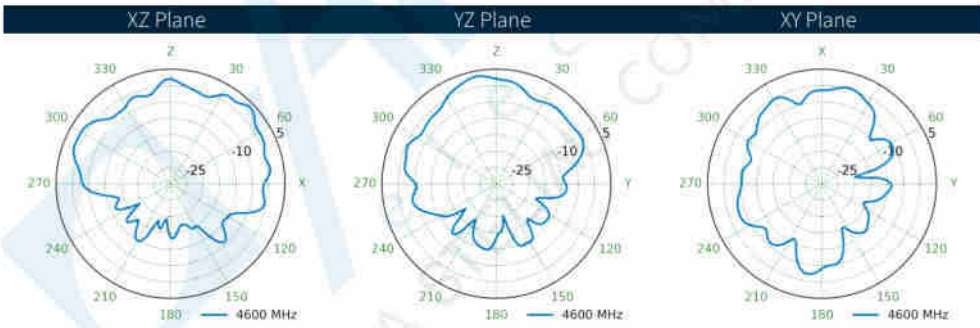
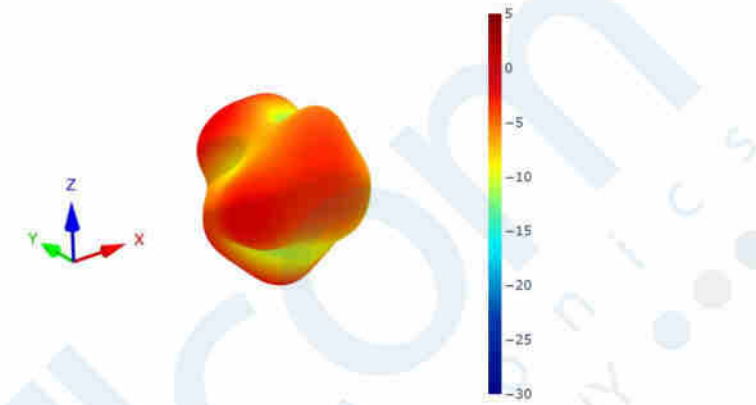
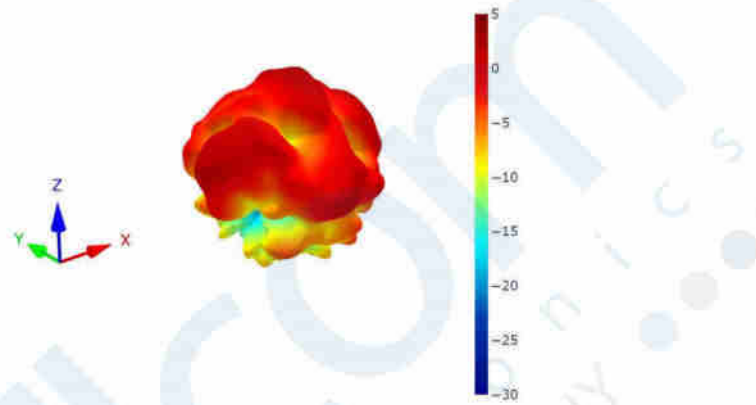

8.18 Cellular 7 Patterns at 751 MHz

8.87 Cellular 4 Patterns at 4600 MHz

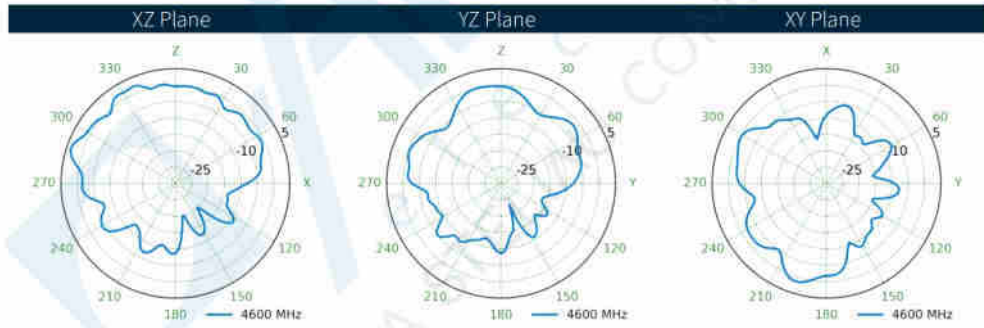
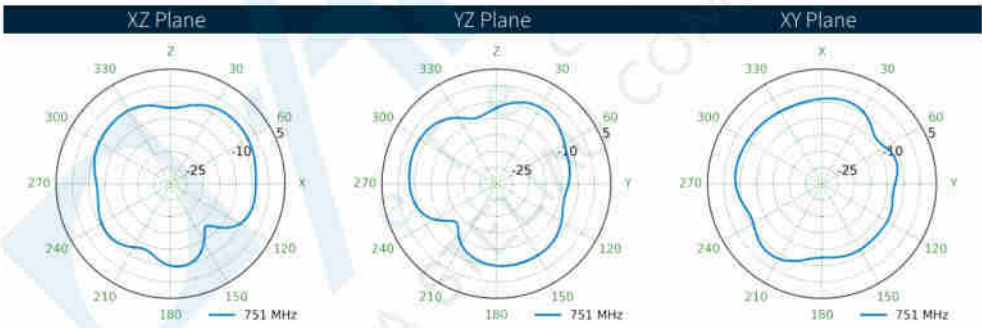
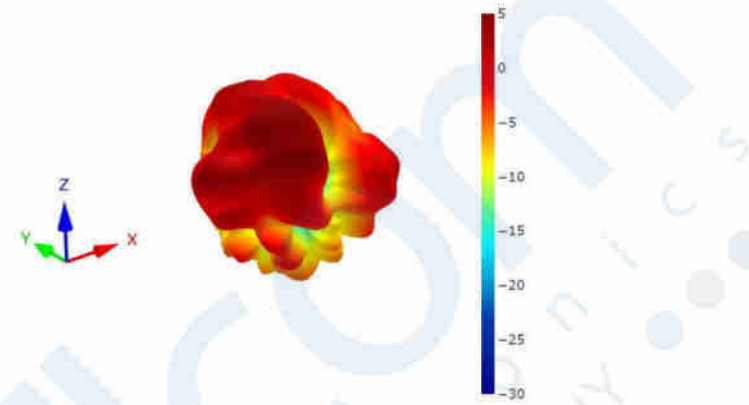
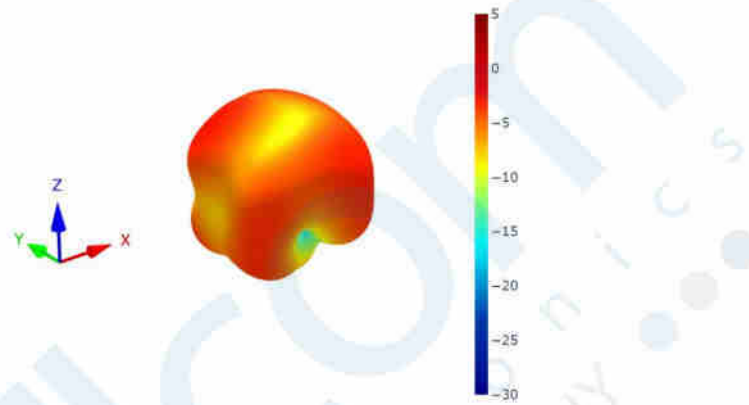

8.86 Cellular 3 Patterns at 4600 MHz

8.19 Cellular 8 Patterns at 751 MHz

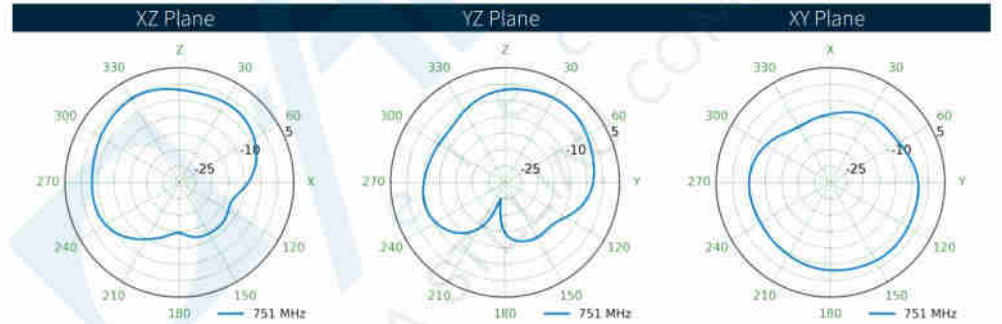
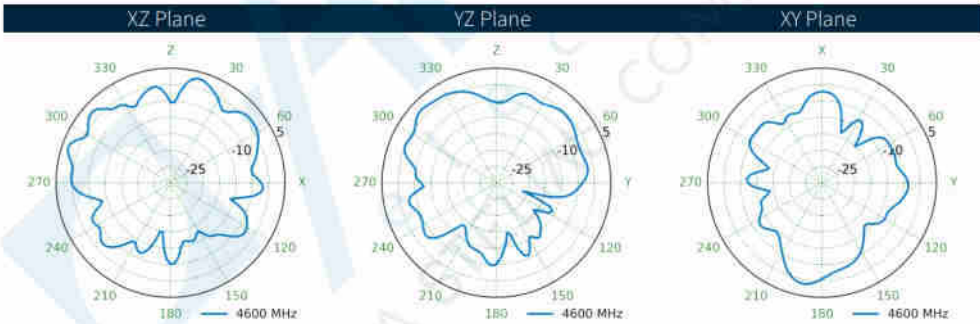
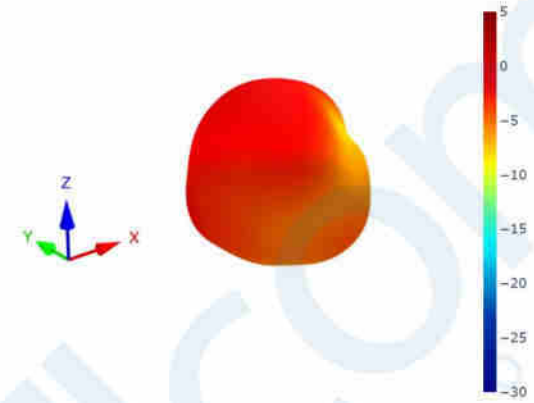
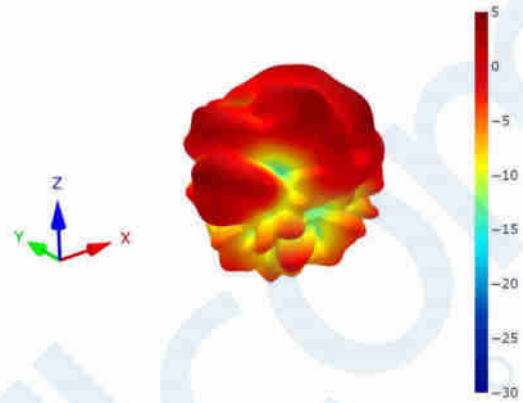

8.20 Cellular 1 Patterns at 890 MHz

8.85 Cellular 2 Patterns at 4600 MHz

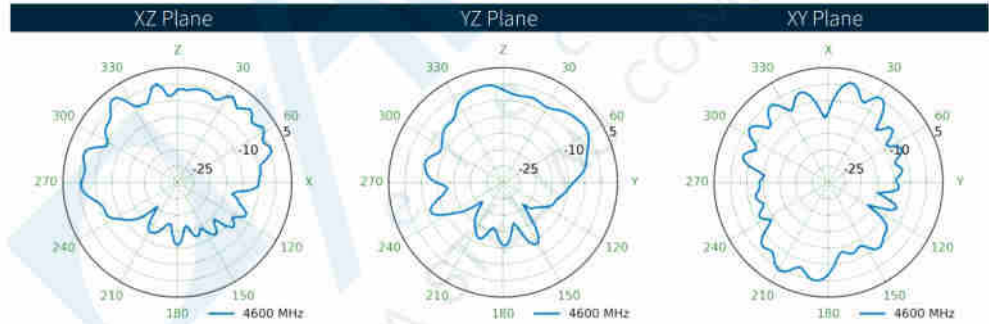
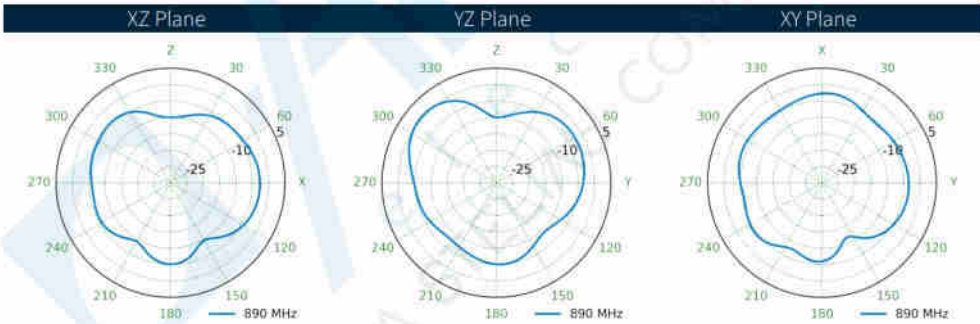
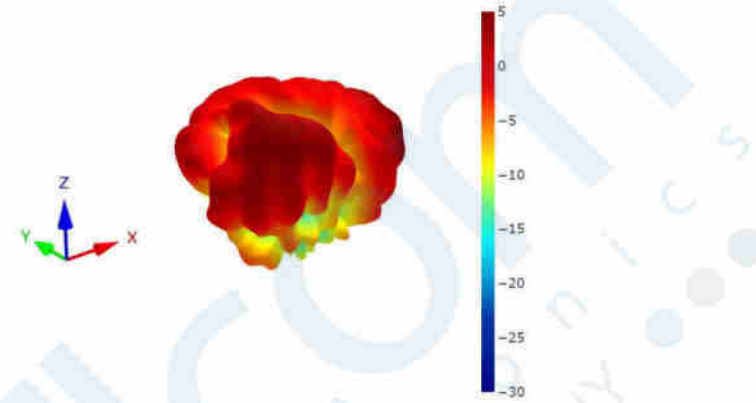
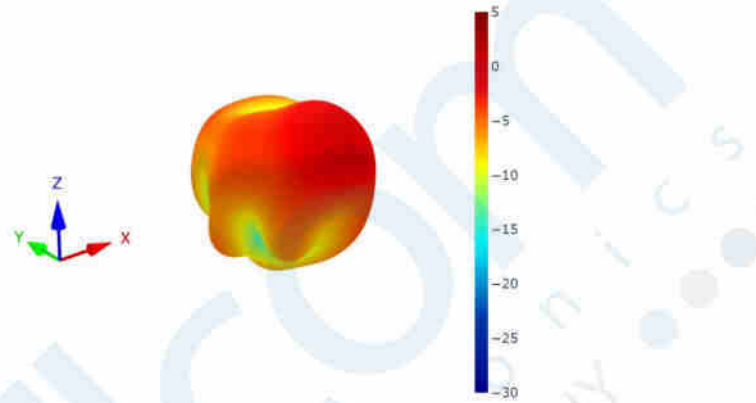

8.84 Cellular 1 Patterns at 4600 MHz

8.21 Cellular 2 Patterns at 890 MHz

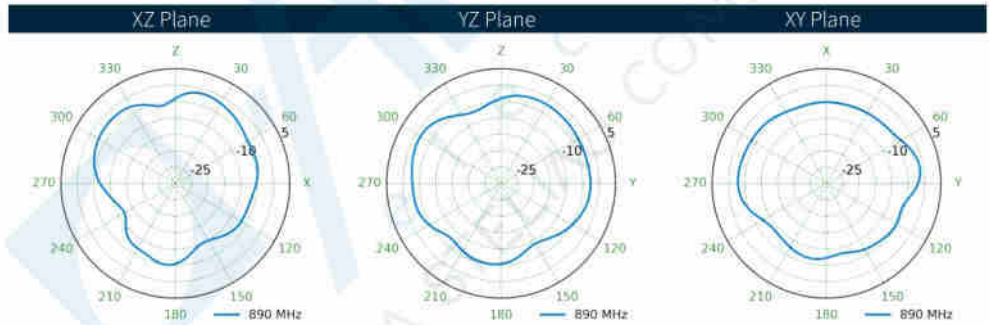
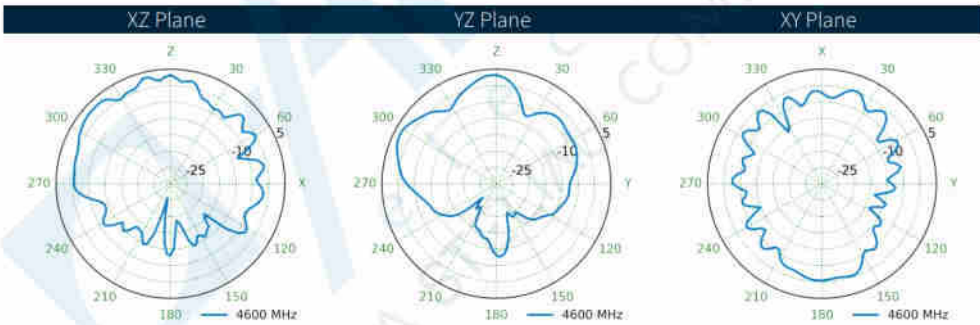
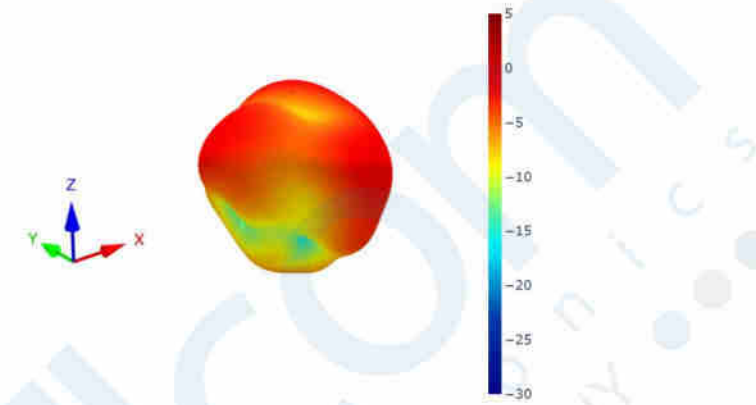
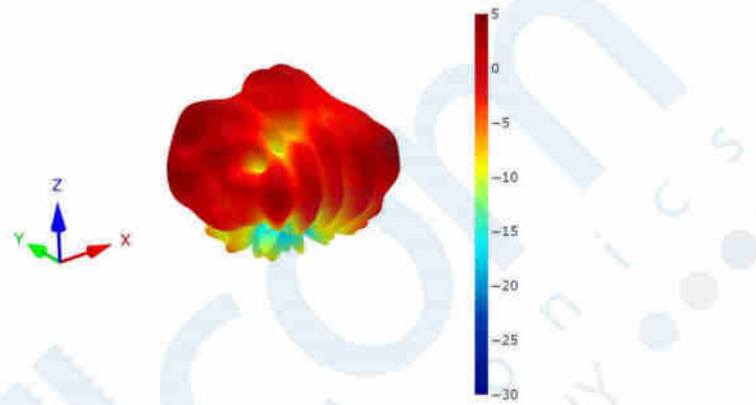

8.22 Cellular 3 Patterns at 890 MHz

8.83 Cellular 8 Patterns at 3550 MHz

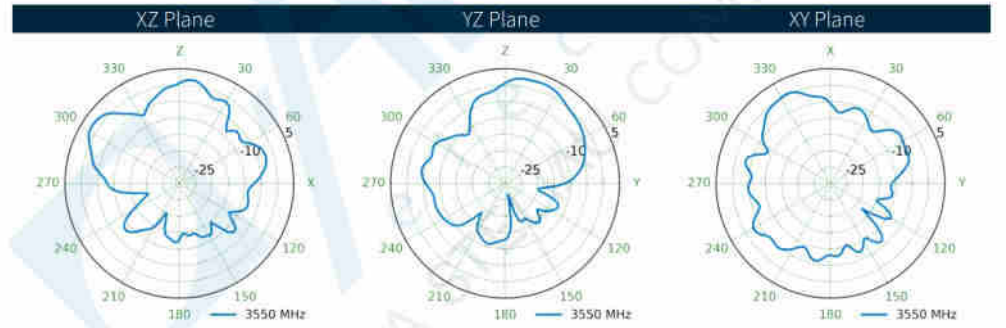
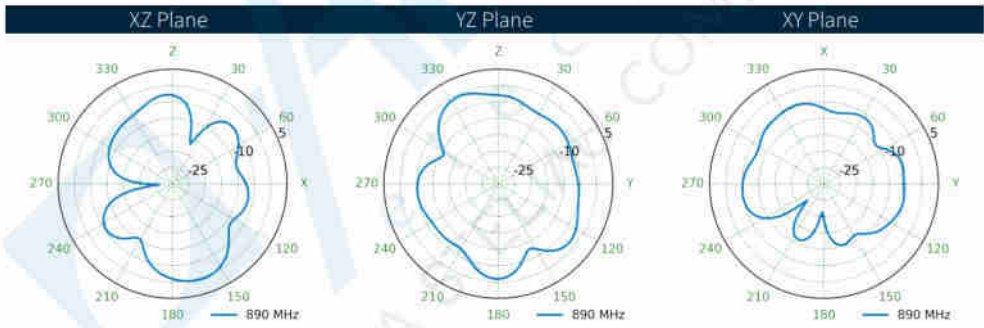
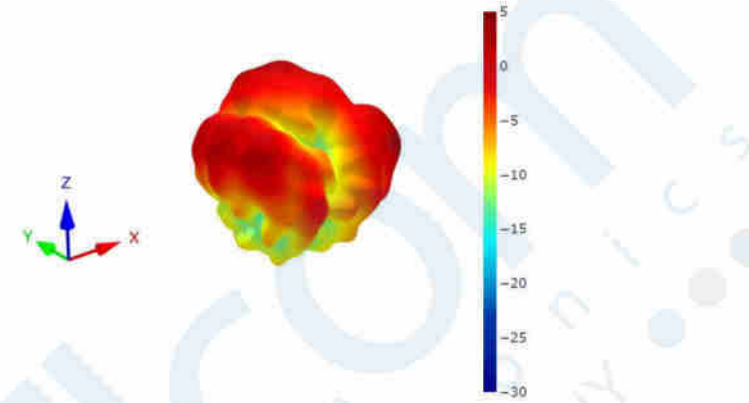
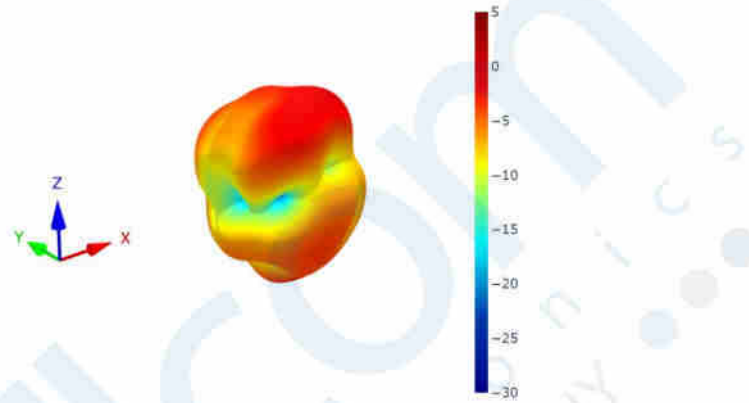

8.82 Cellular 7 Patterns at 3550 MHz

8.23 Cellular 4 Patterns at 890 MHz

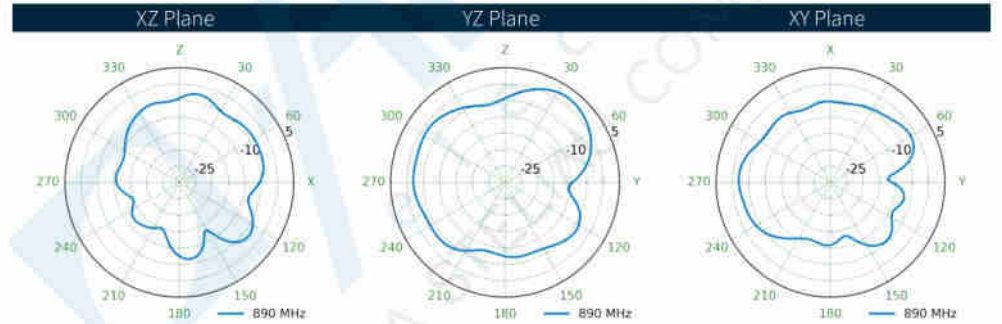
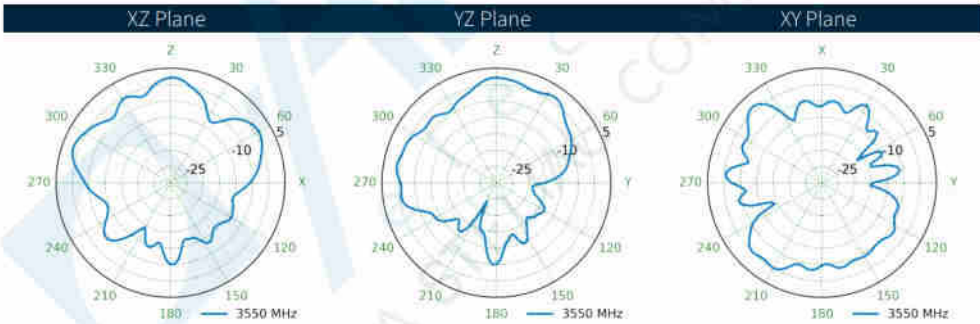
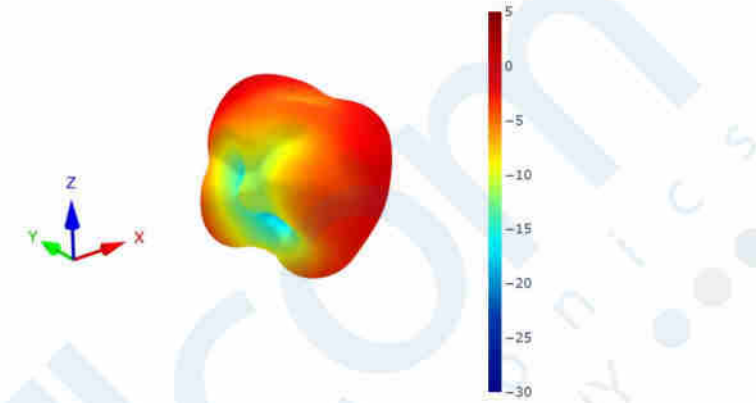
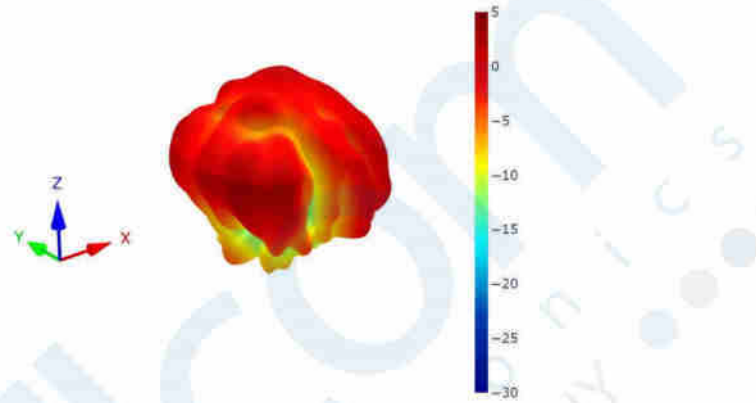

8.24 Cellular 5 Patterns at 890 MHz

8.81 Cellular 6 Patterns at 3550 MHz

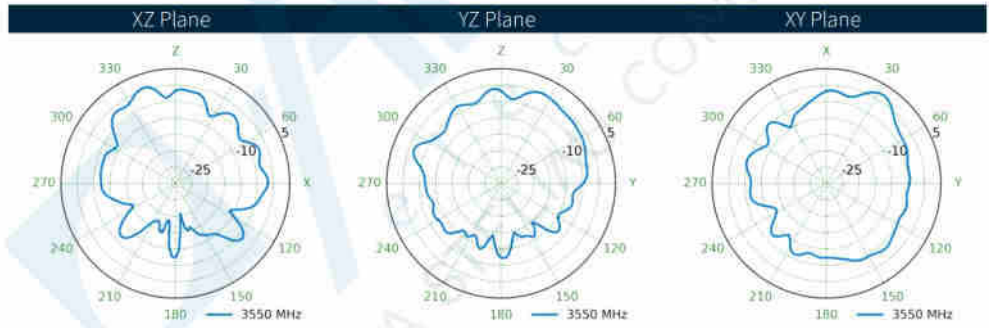
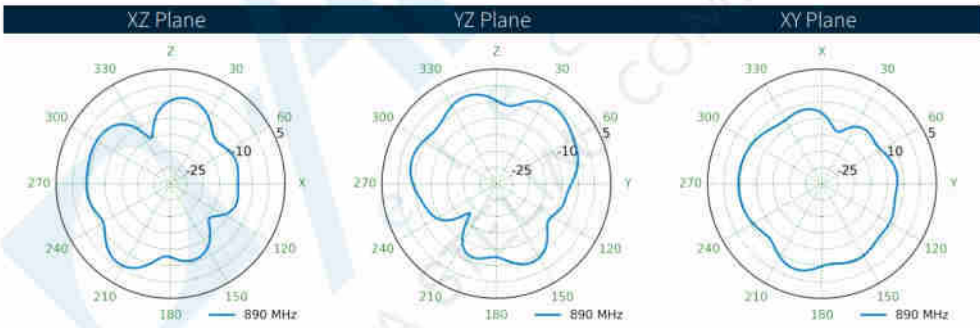
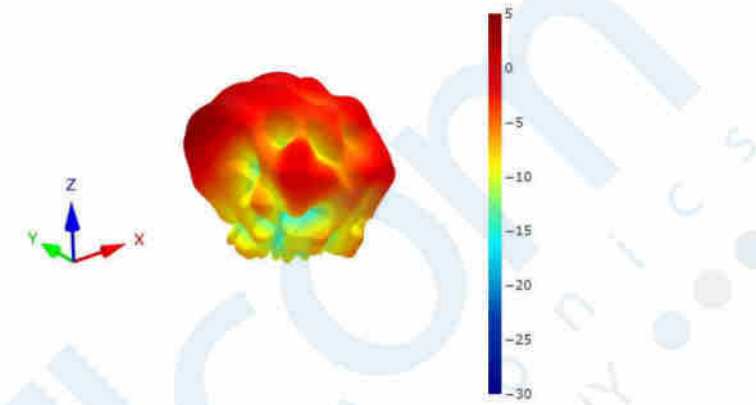
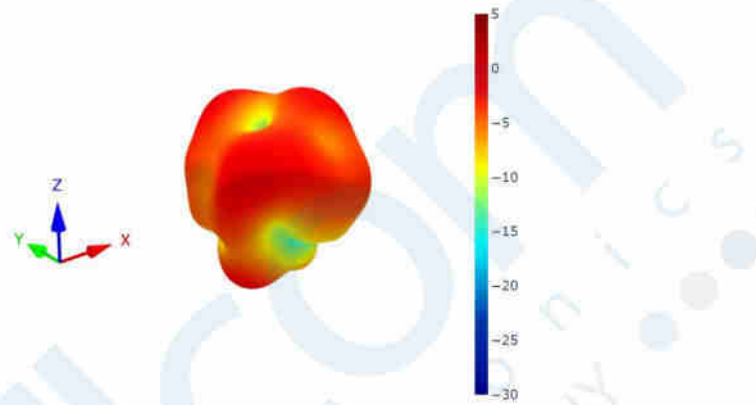

8.80 Cellular 5 Patterns at 3550 MHz

8.25 Cellular 6 Patterns at 890 MHz

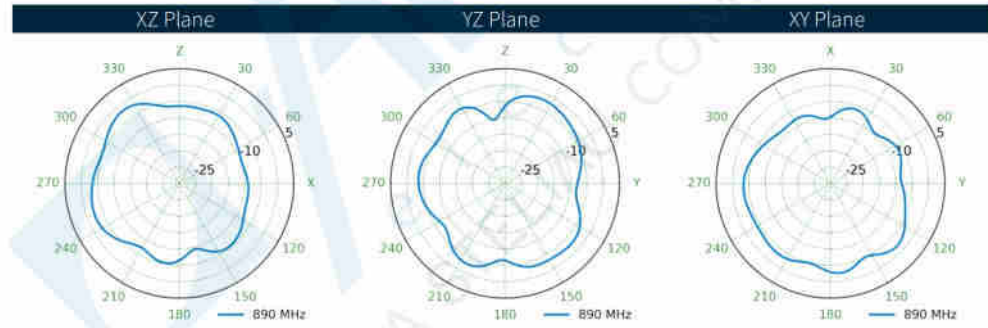
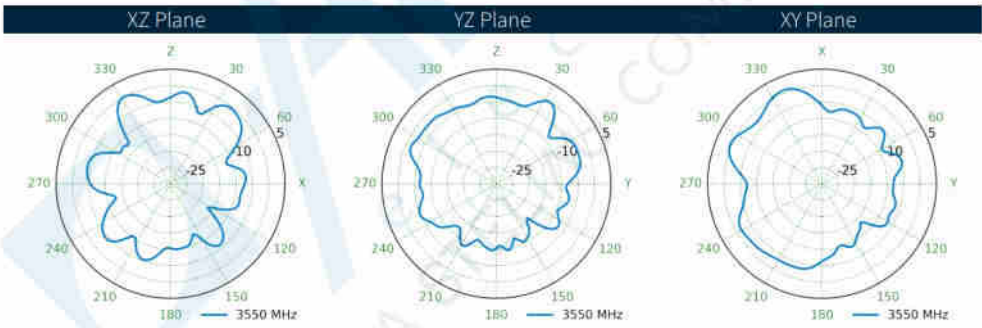
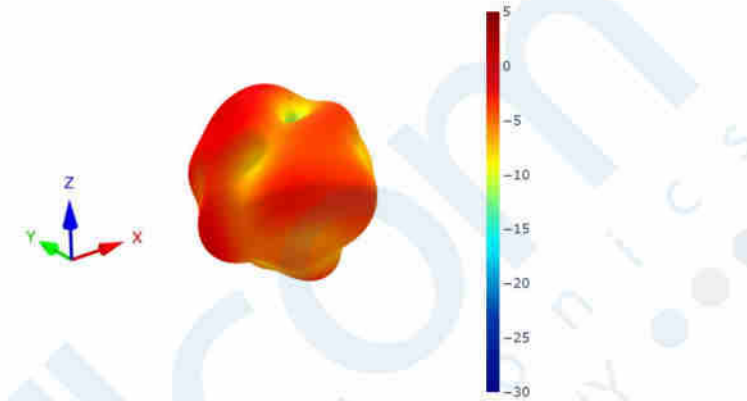
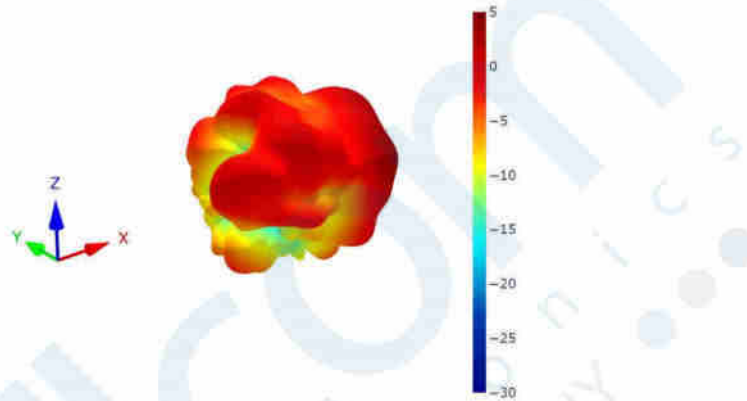

8.26 Cellular 7 Patterns at 890 MHz

8.79 Cellular 4 Patterns at 3550 MHz

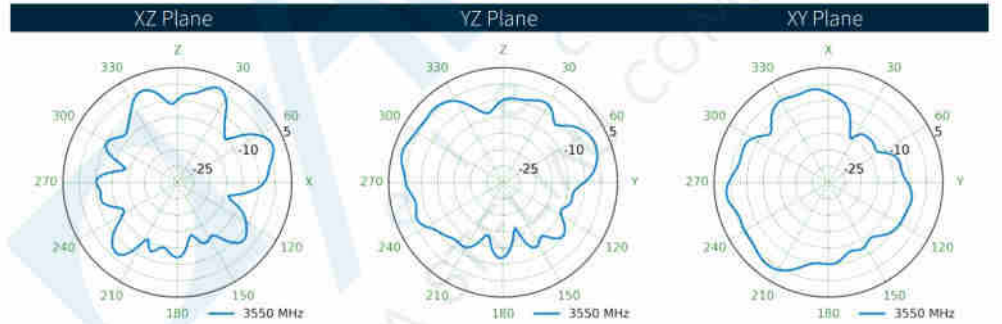
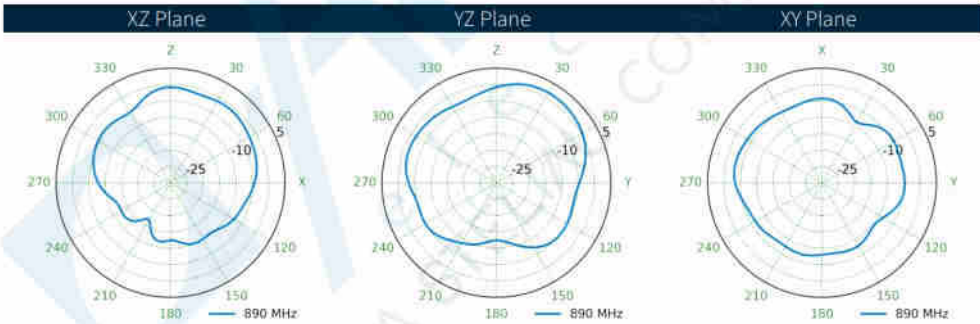
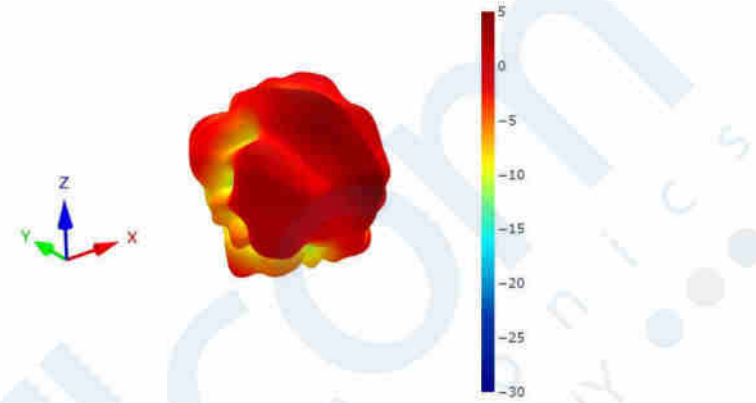
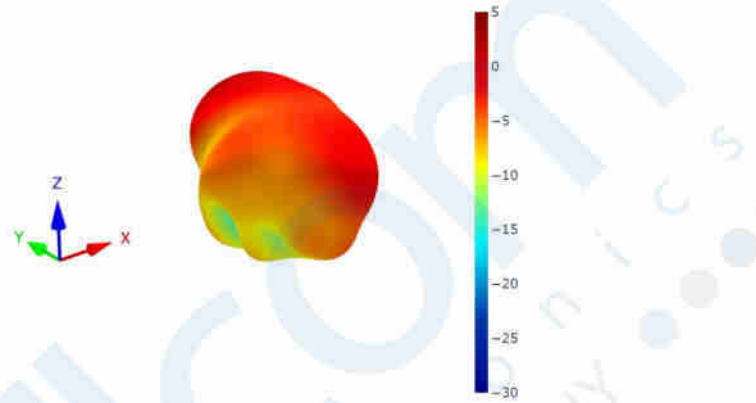

8.78 Cellular 3 Patterns at 3550 MHz

8.27 Cellular 8 Patterns at 890 MHz

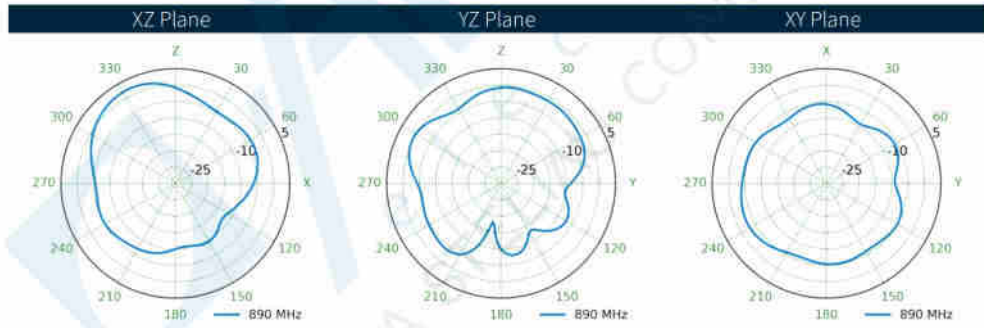
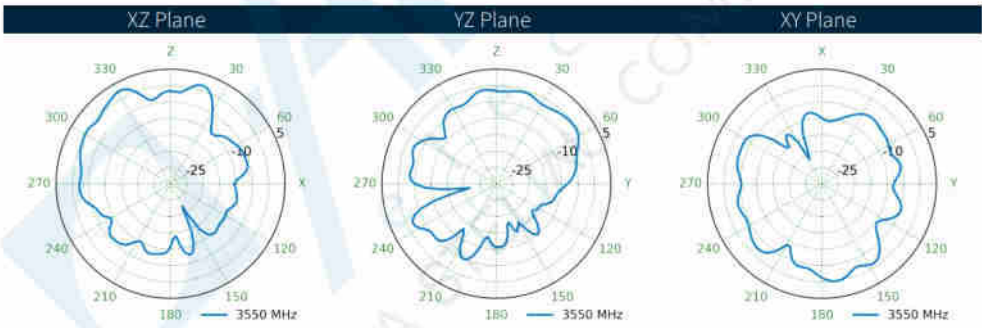
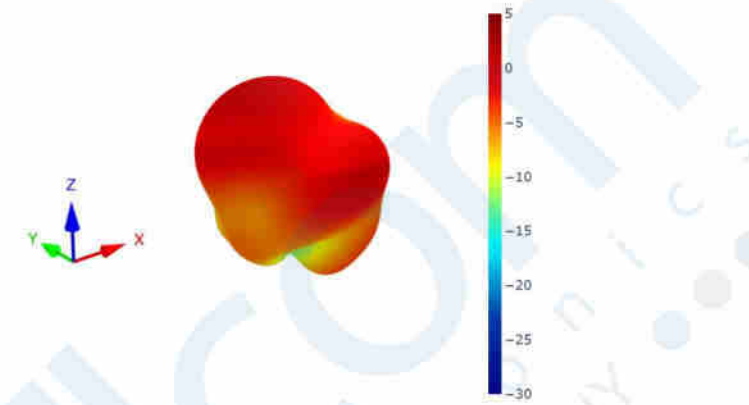
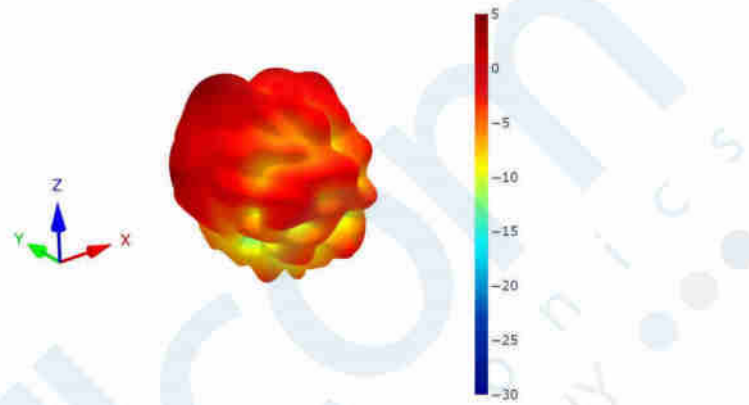

8.28 Cellular 1 Patterns at 1470 MHz

8.77 Cellular 2 Patterns at 3550 MHz

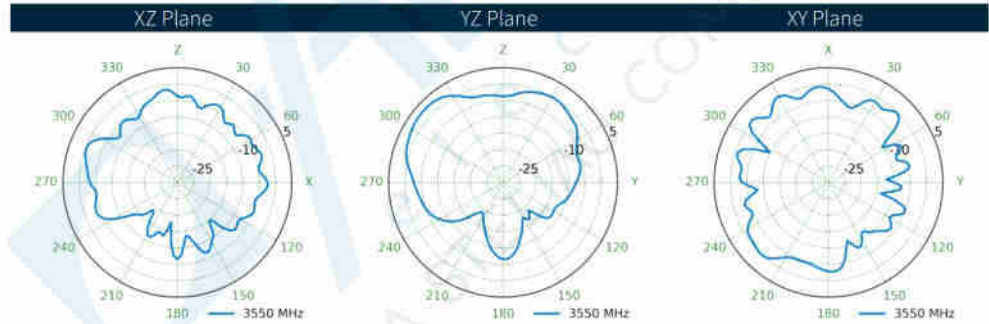
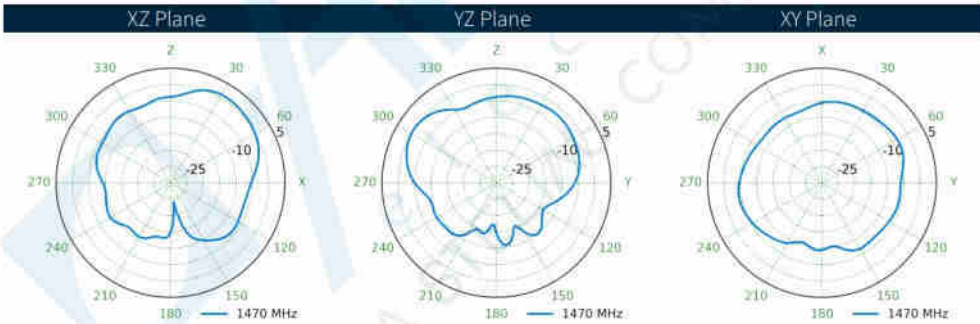
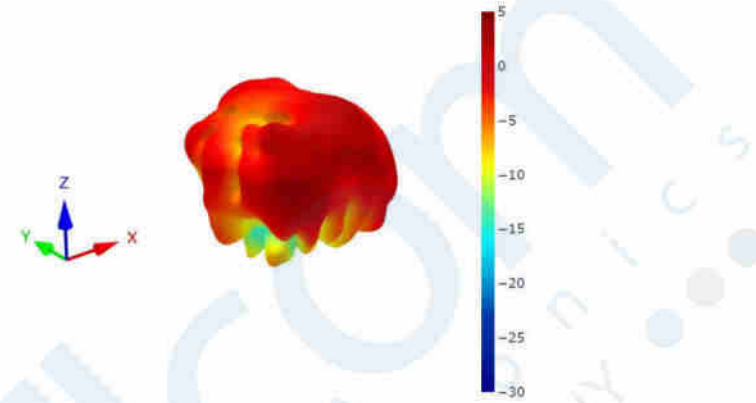
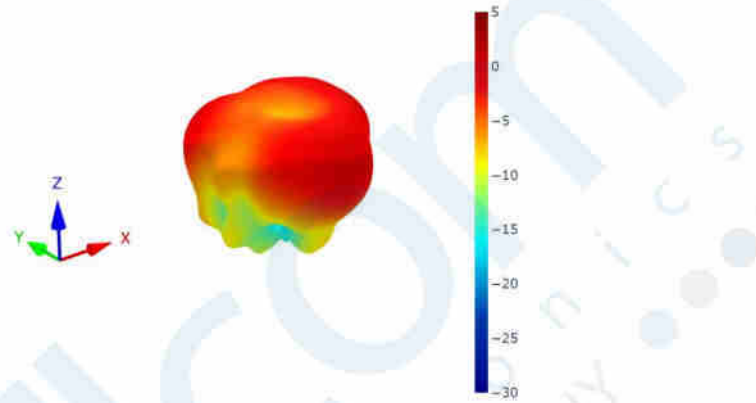

8.76 Cellular 1 Patterns at 3550 MHz

8.29 Cellular 2 Patterns at 1470 MHz

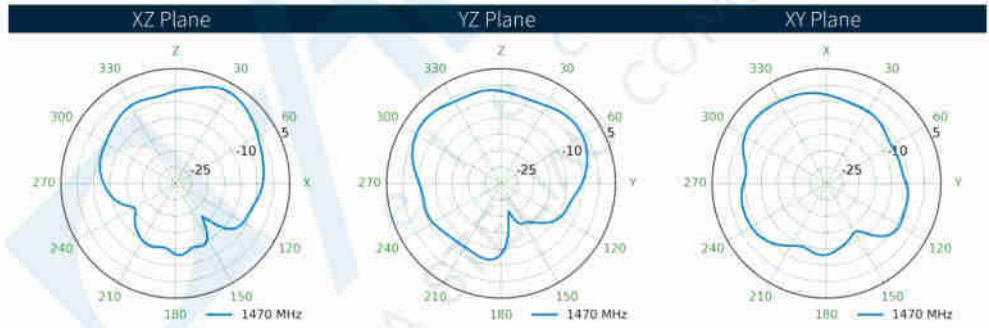
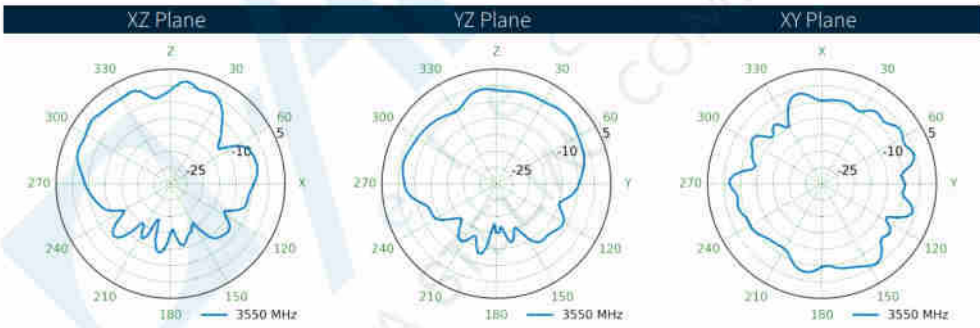
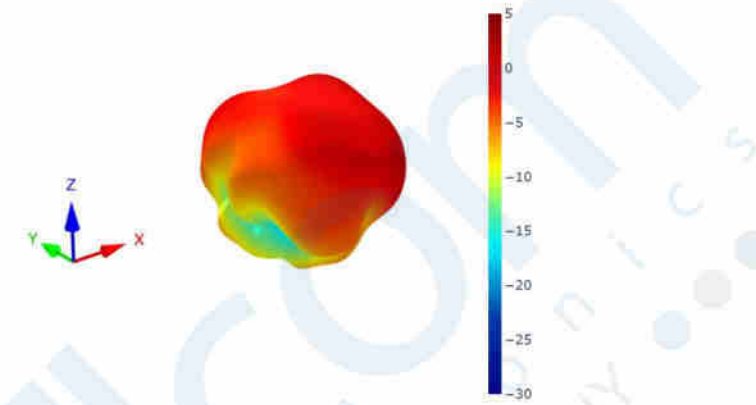
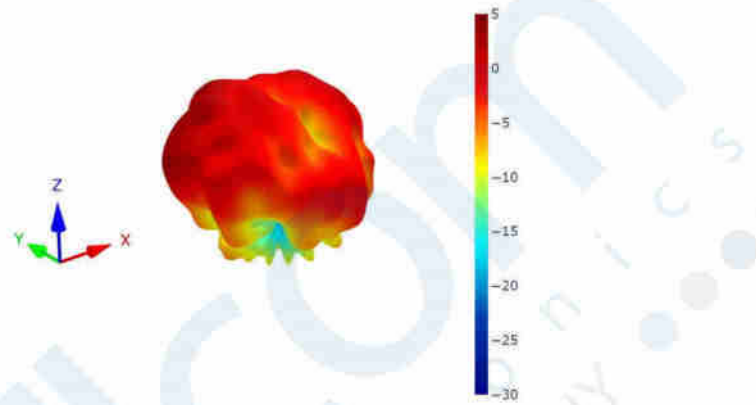

8.30 Cellular 3 Patterns at 1470 MHz

8.75 Cellular 8 Patterns at 2595 MHz

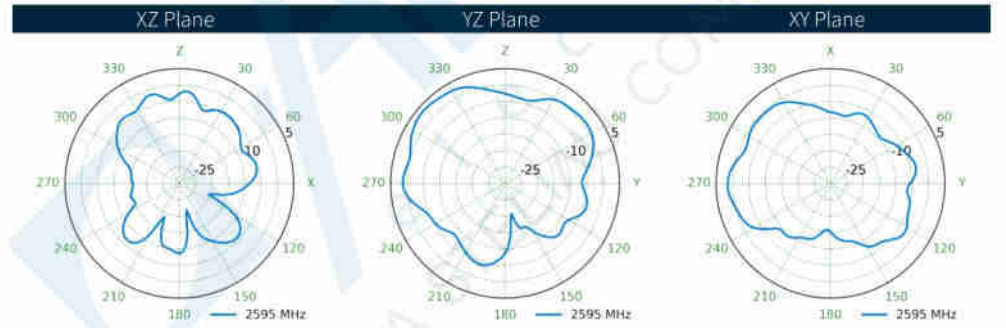
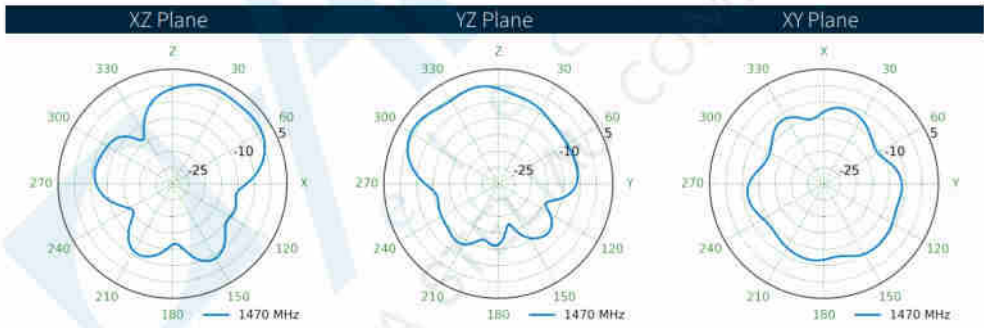
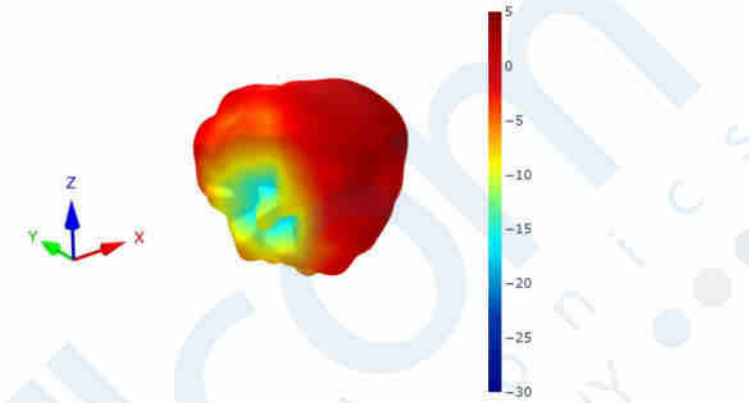
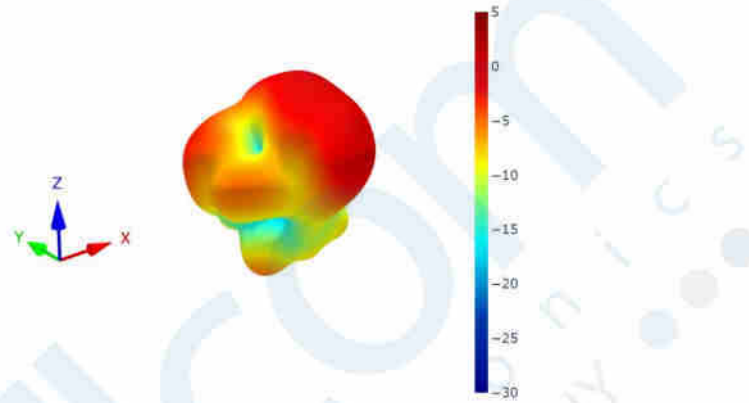

8.74 Cellular 7 Patterns at 2595 MHz

8.31 Cellular 4 Patterns at 1470 MHz

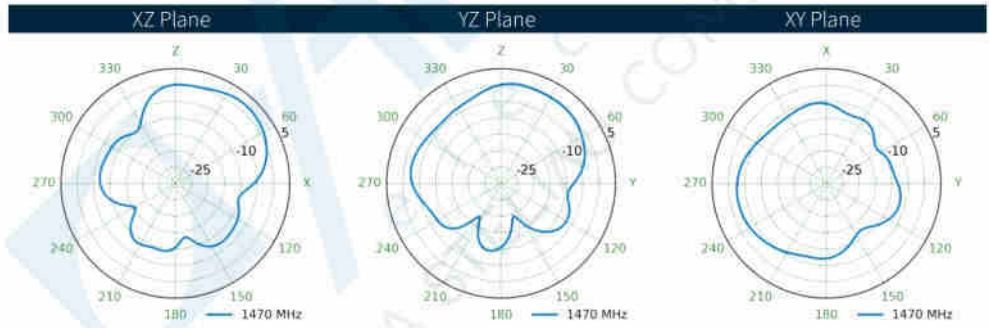
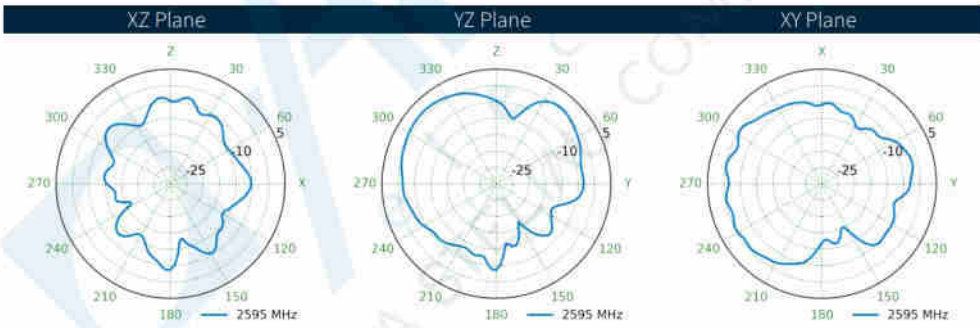
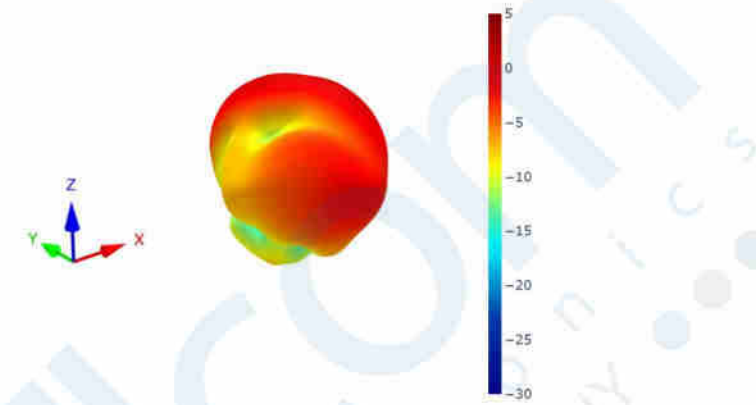
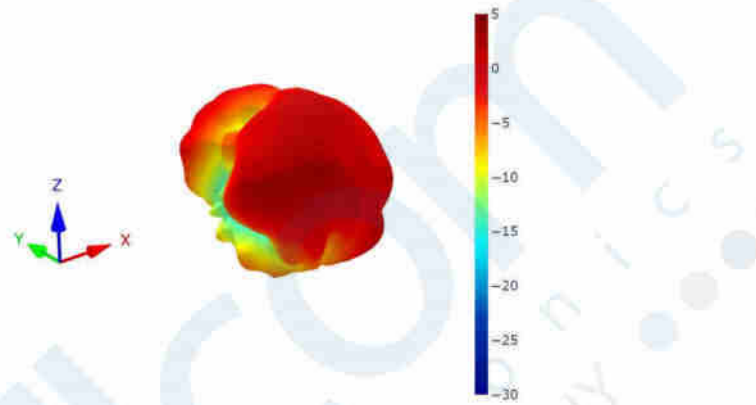

8.32 Cellular 5 Patterns at 1470 MHz

8.73 Cellular 6 Patterns at 2595 MHz

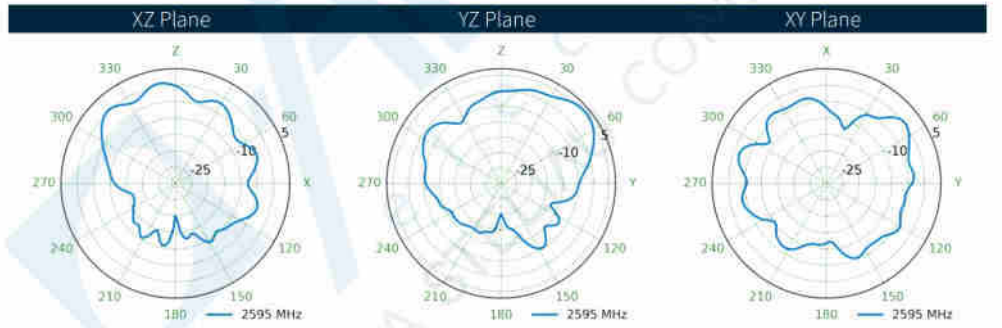
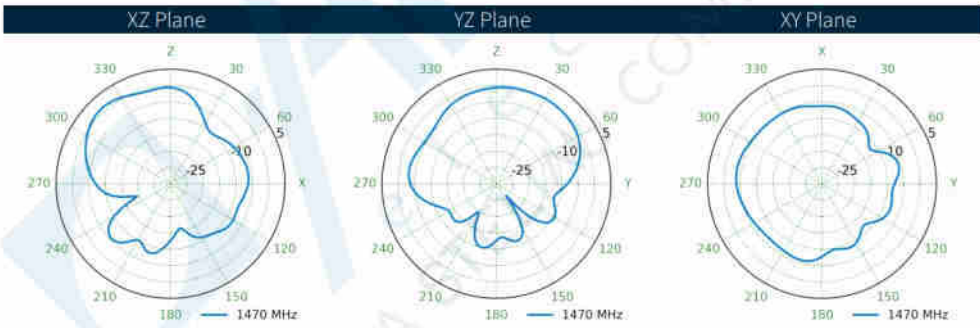
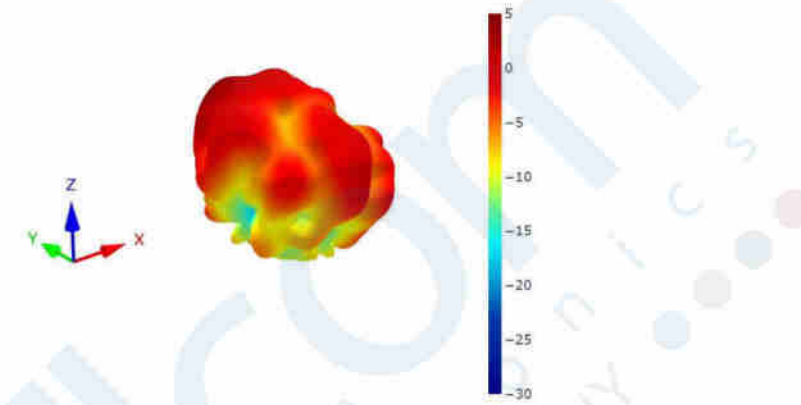
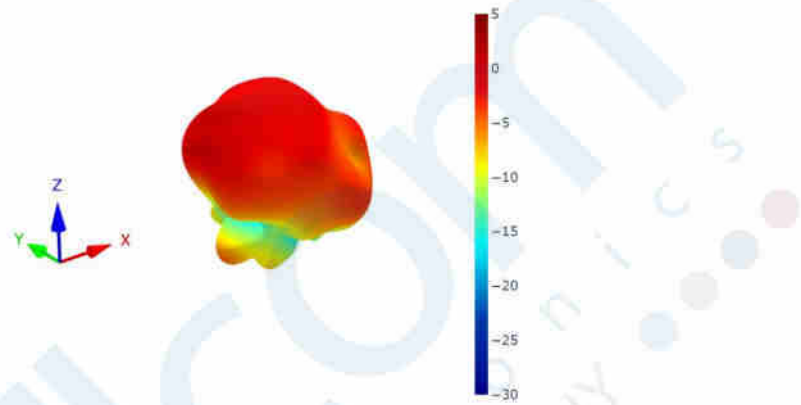

8.72 Cellular 5 Patterns at 2595 MHz

8.33 Cellular 6 Patterns at 1470 MHz

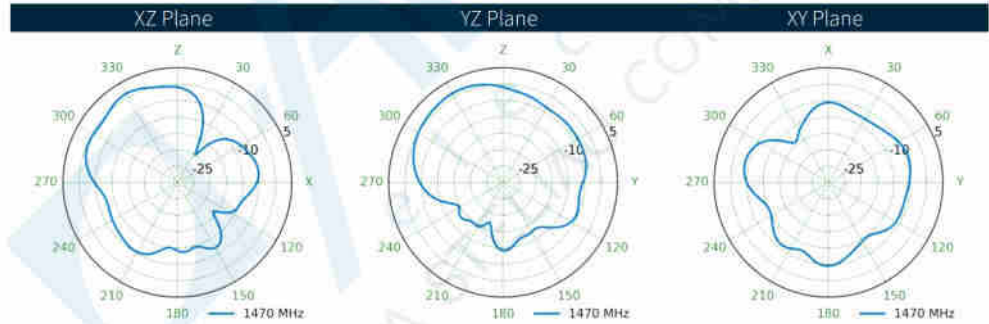
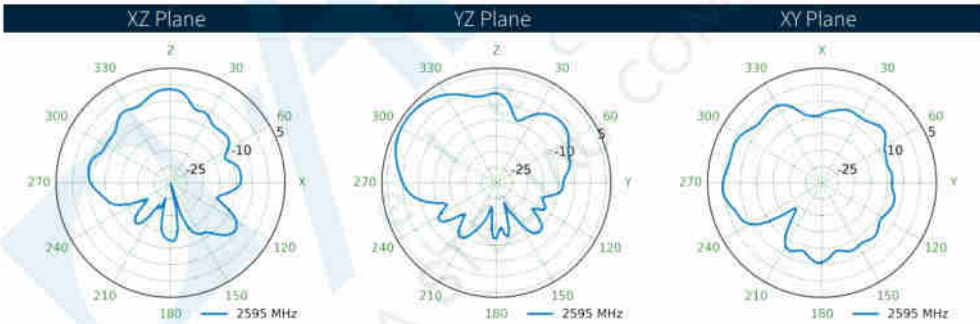
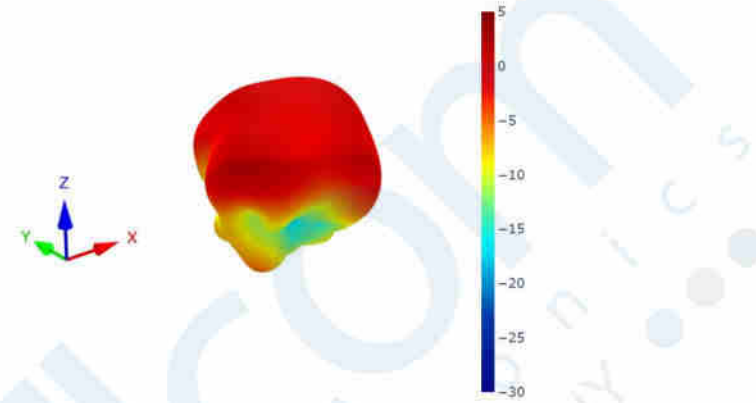
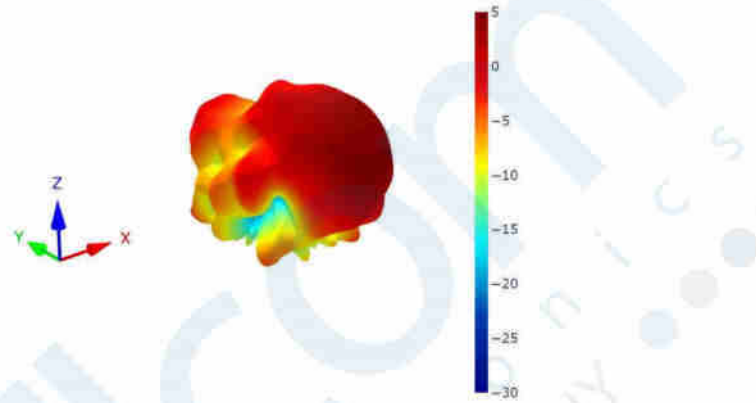

8.34 Cellular 7 Patterns at 1470 MHz

8.71 Cellular 4 Patterns at 2595 MHz

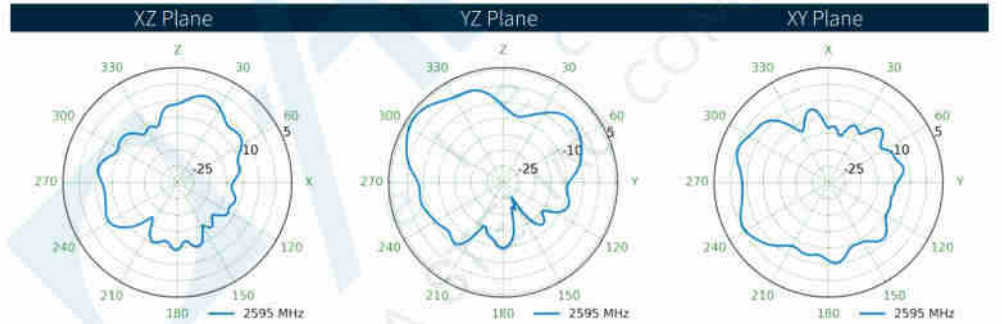
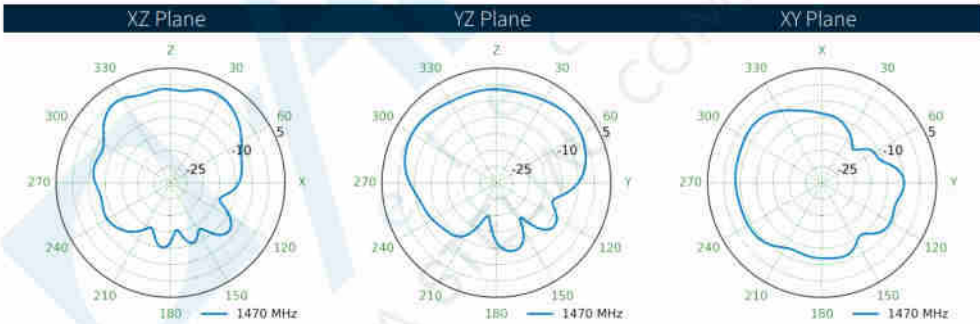
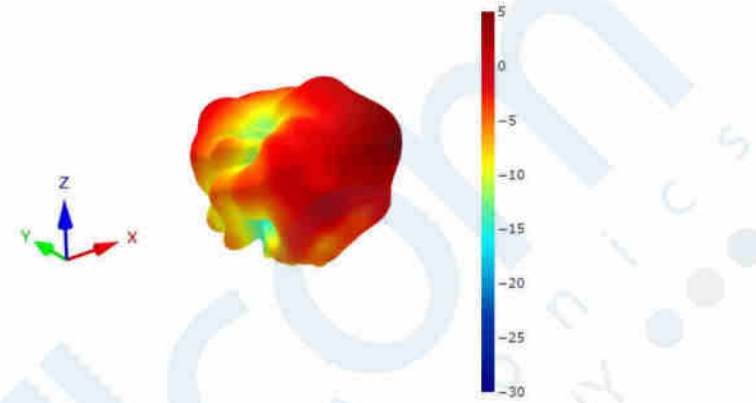
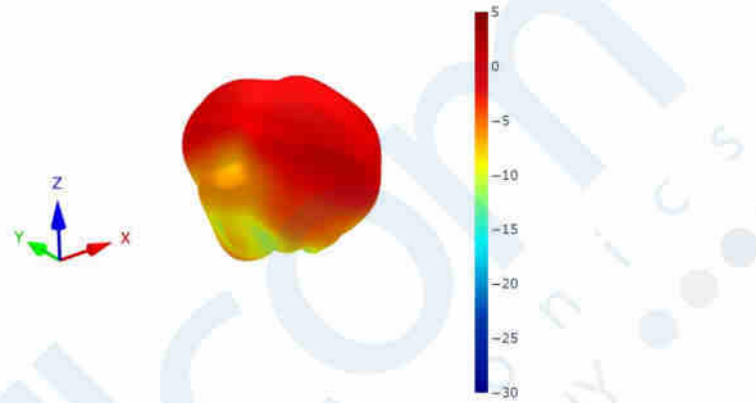

8.70 Cellular 3 Patterns at 2595 MHz

8.35 Cellular 8 Patterns at 1470 MHz

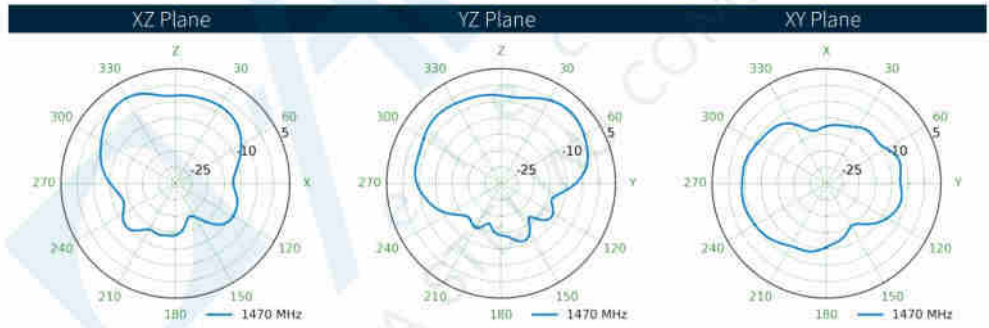
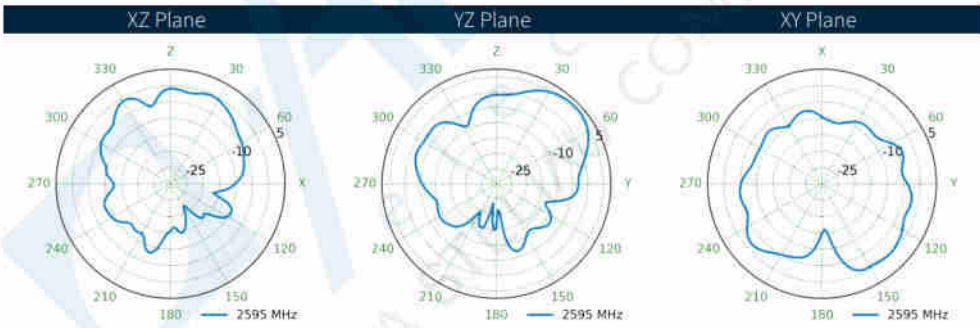
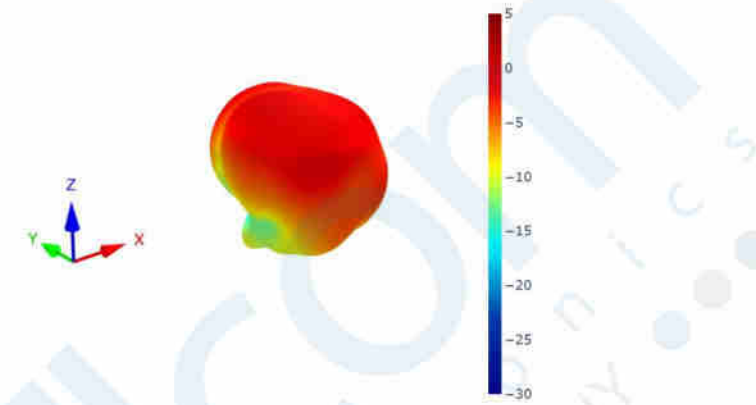
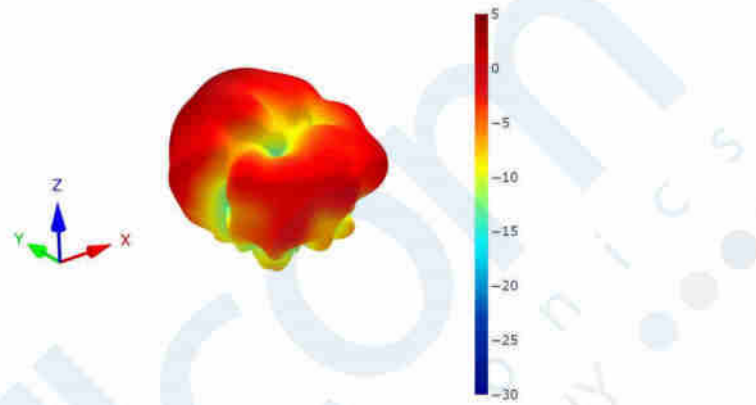

8.36 Cellular 1 Patterns at 1805 MHz

8.69 Cellular 2 Patterns at 2595 MHz

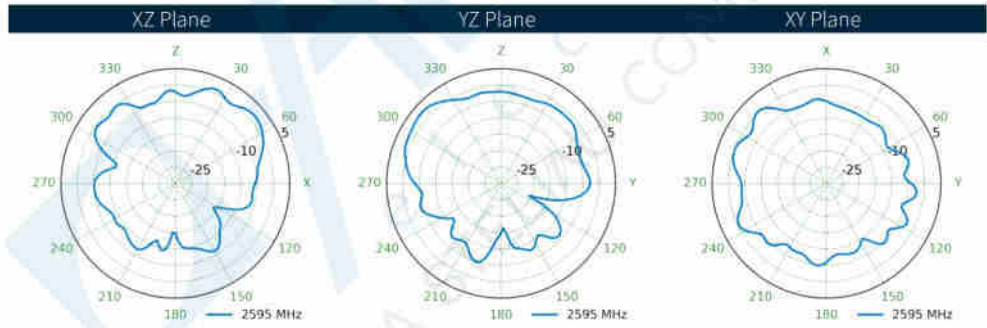
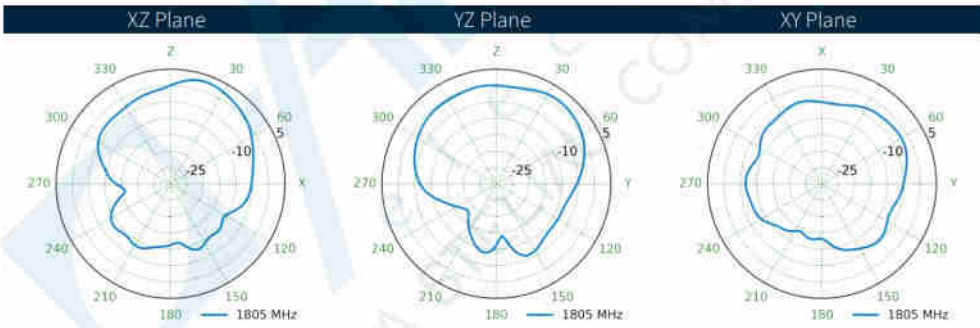
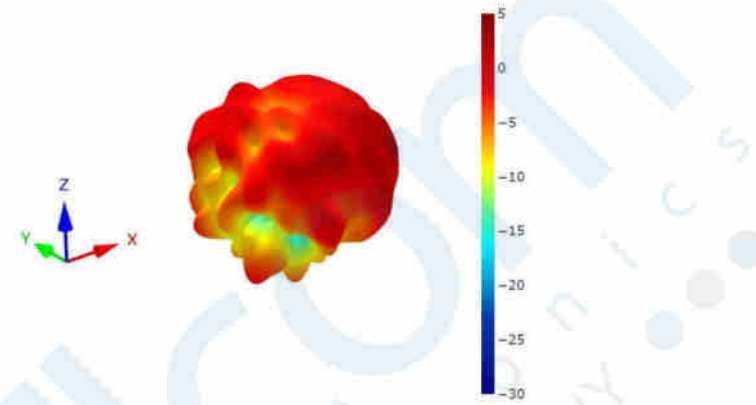
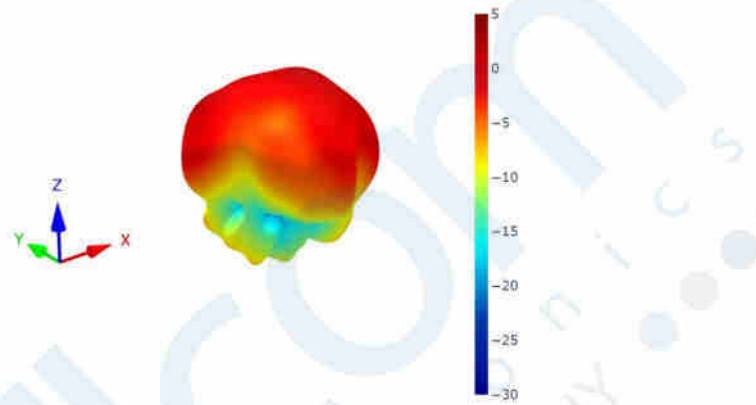

8.68 Cellular 1 Patterns at 2595 MHz

8.37 Cellular 2 Patterns at 1805 MHz

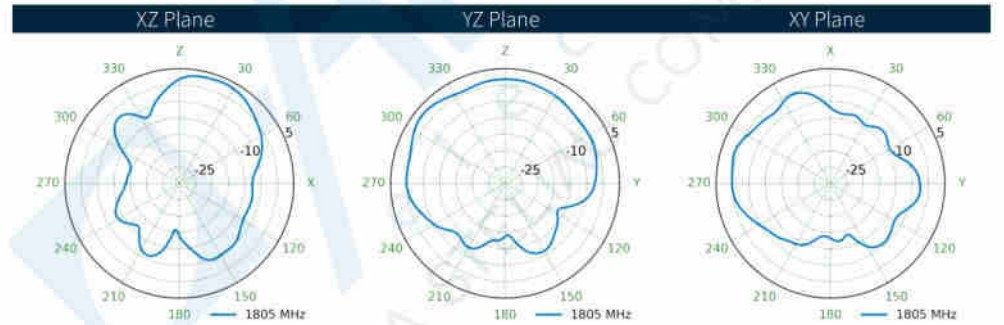
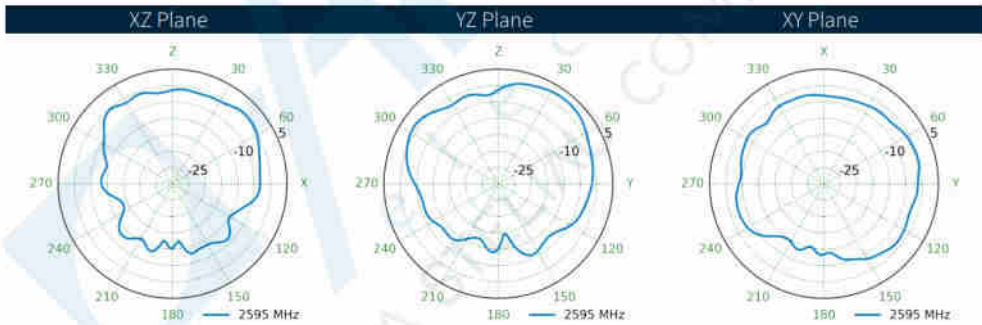
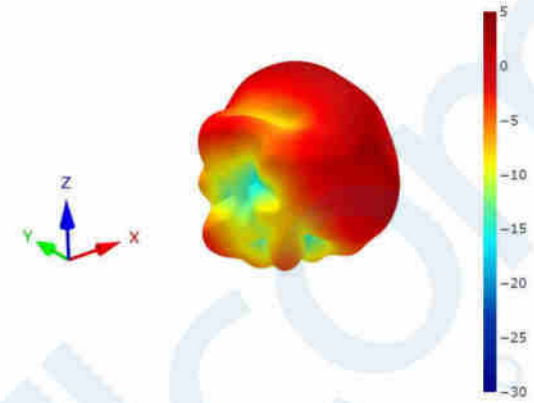
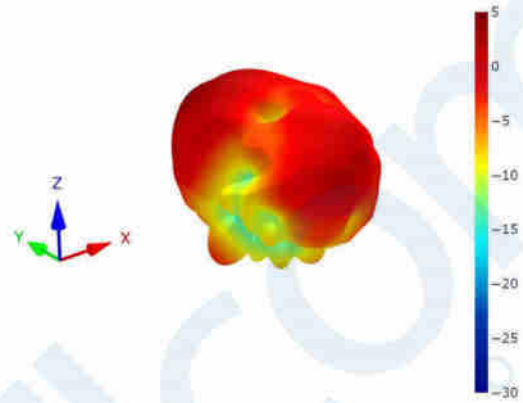

8.38 Cellular 3 Patterns at 1805 MHz

8.67 Cellular 8 Patterns at 2360 MHz

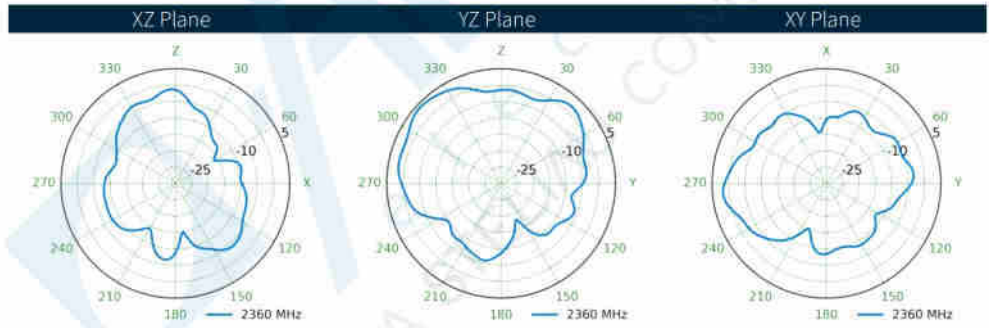
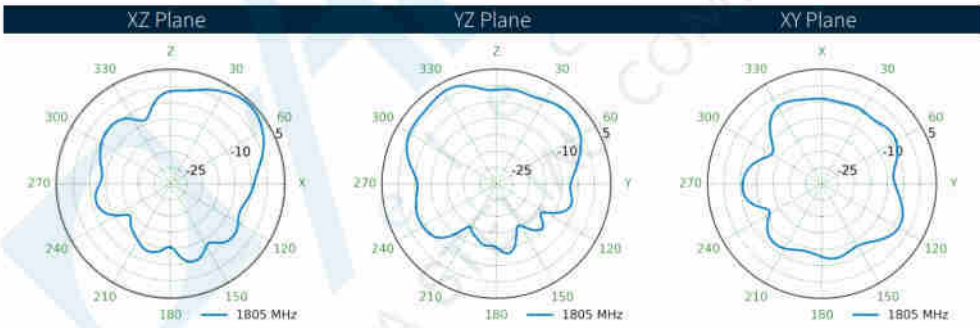
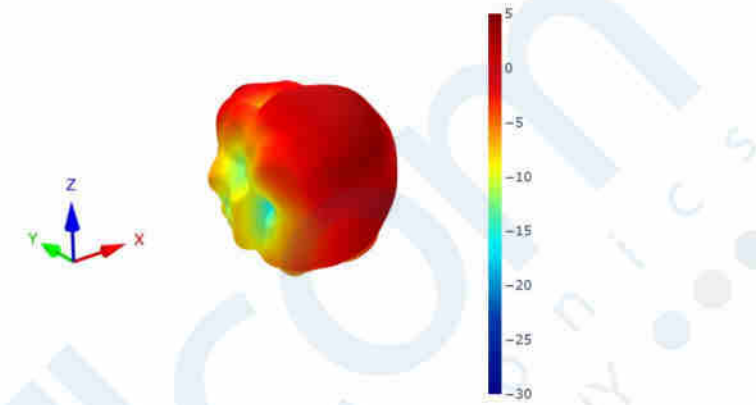
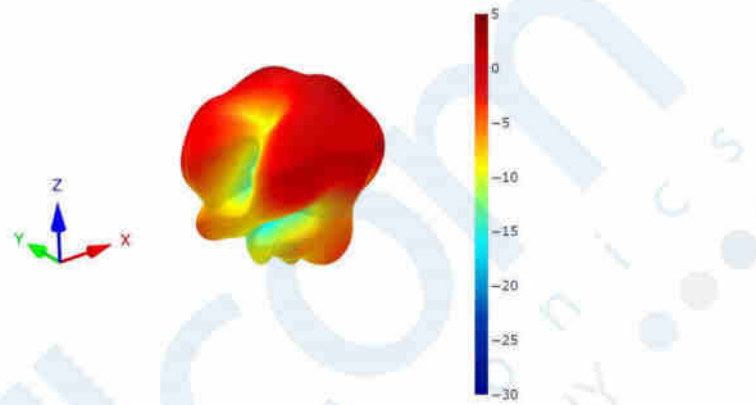

8.66 Cellular 7 Patterns at 2360 MHz

8.39 Cellular 4 Patterns at 1805 MHz

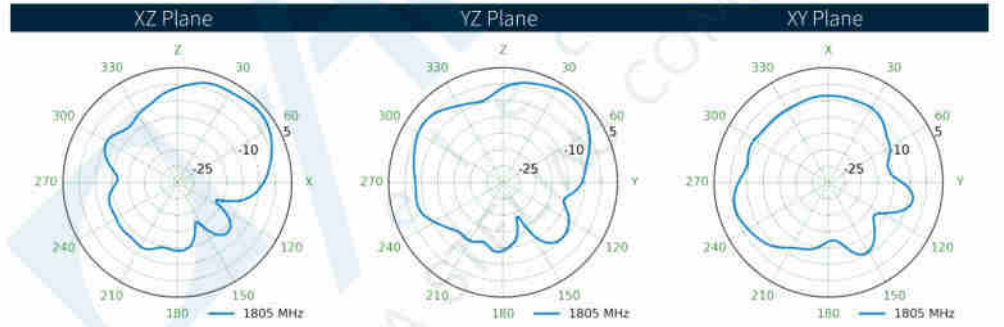
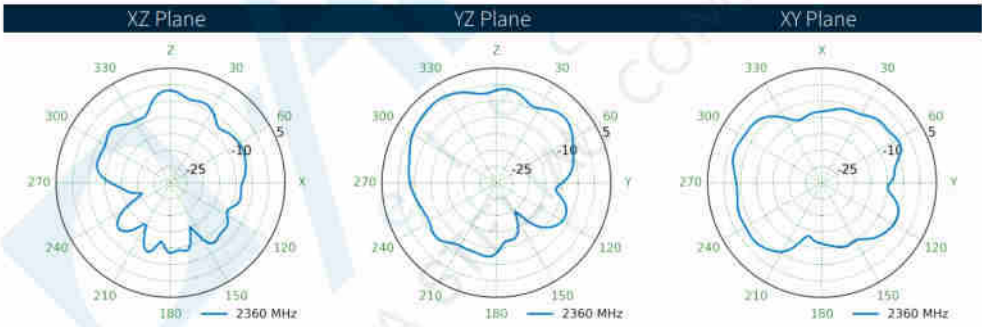
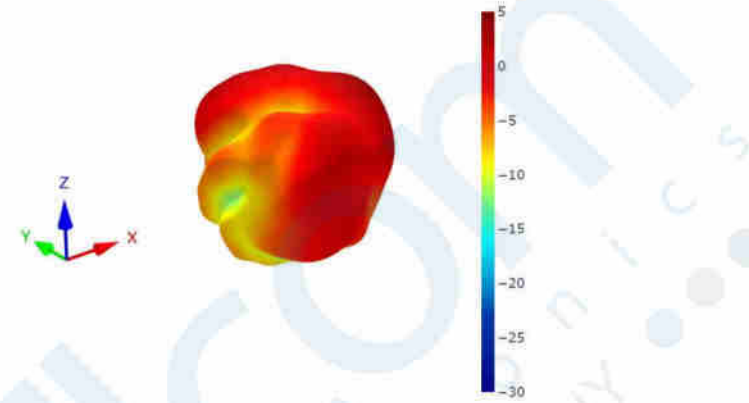
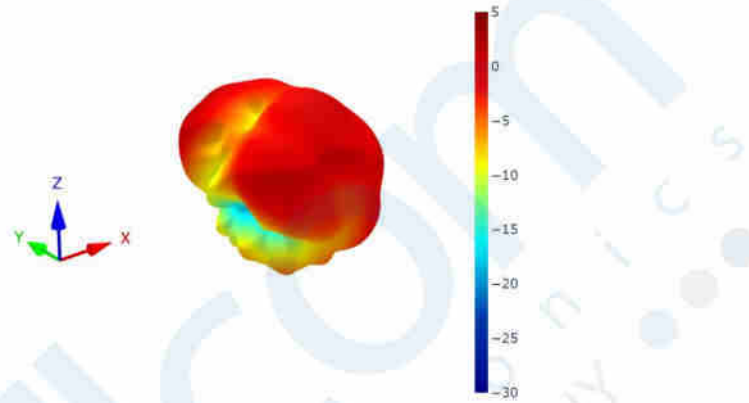

8.40 Cellular 5 Patterns at 1805 MHz

8.65 Cellular 6 Patterns at 2360 MHz

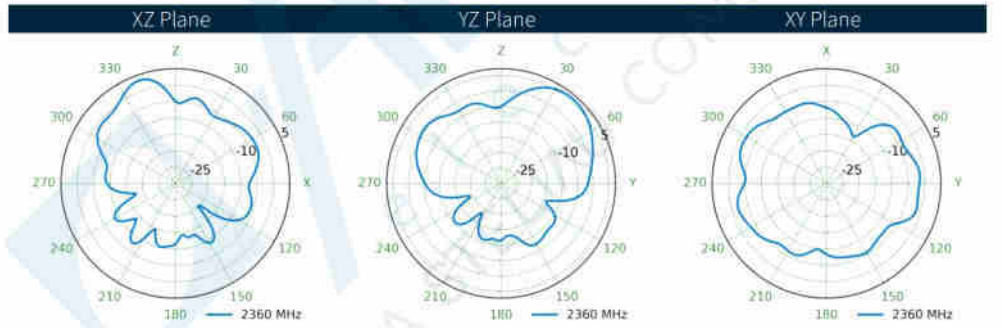
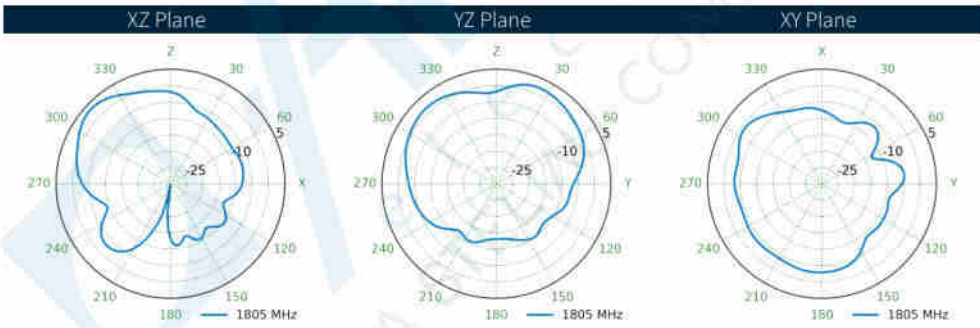
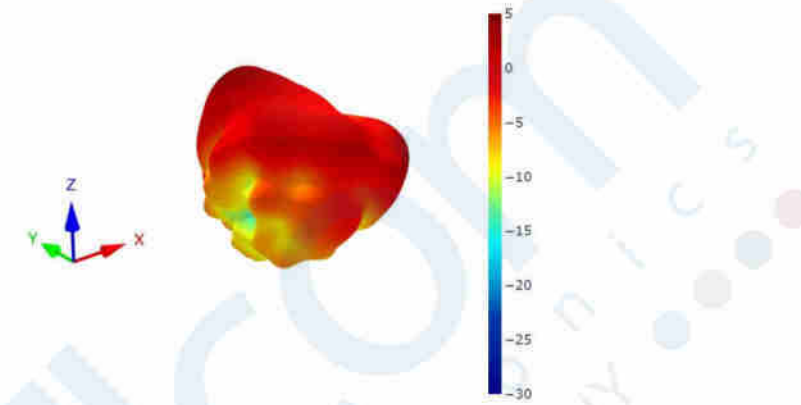
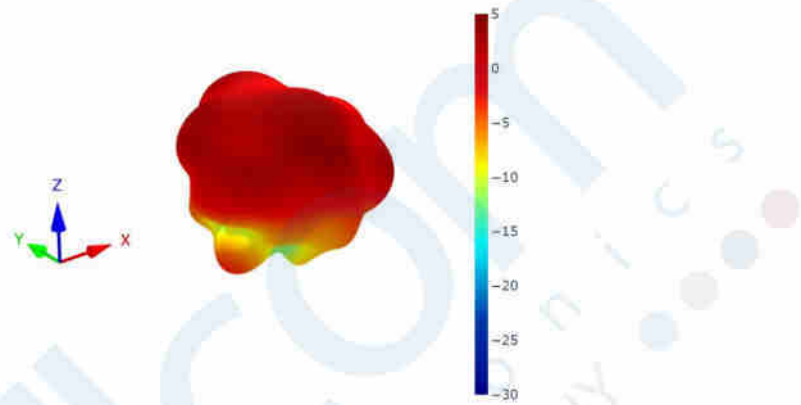

8.64 Cellular 5 Patterns at 2360 MHz

8.41 Cellular 6 Patterns at 1805 MHz

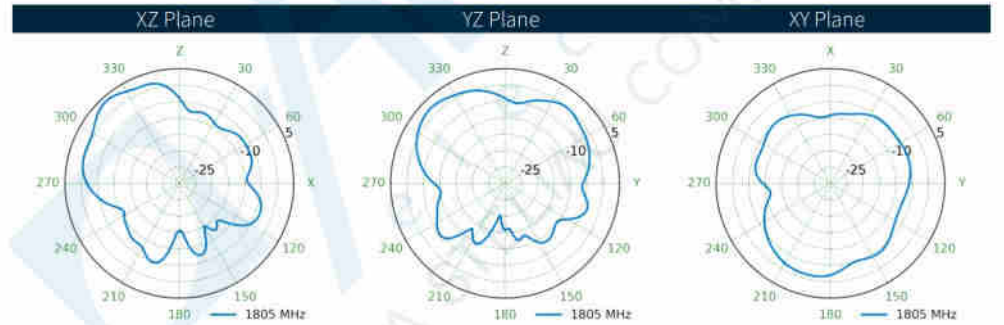
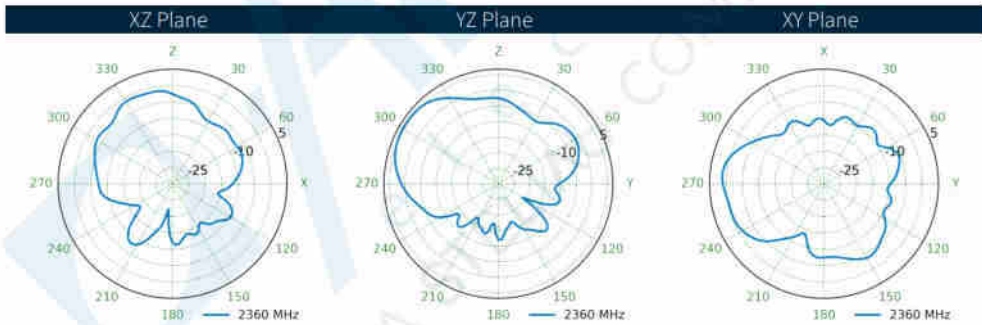
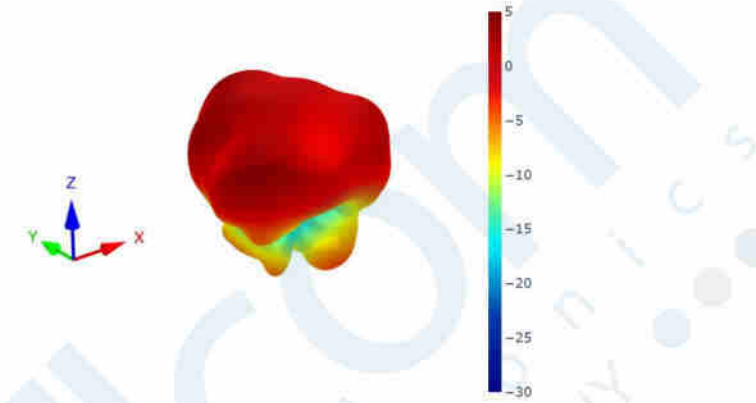
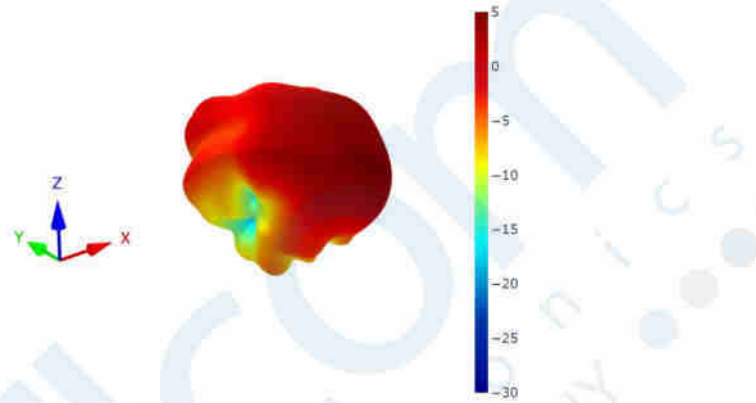

8.42 Cellular 7 Patterns at 1805 MHz

8.63 Cellular 4 Patterns at 2360 MHz

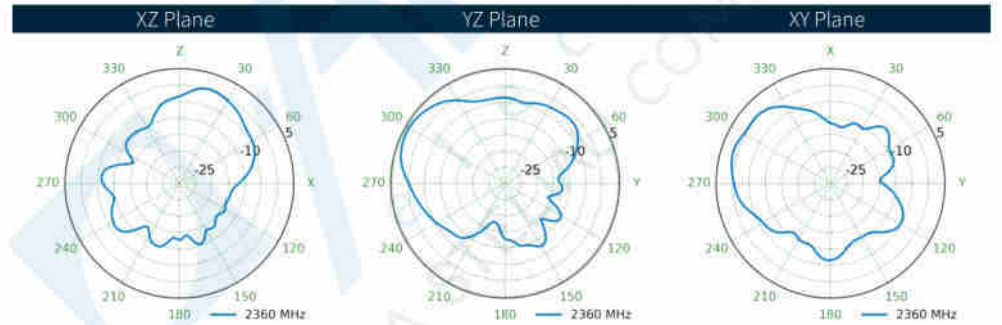
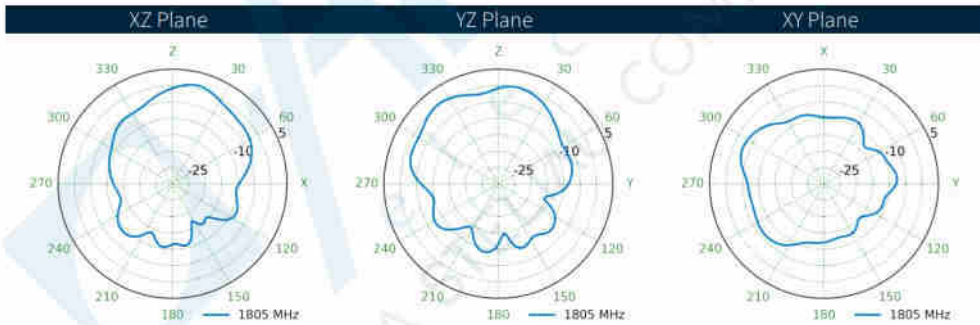
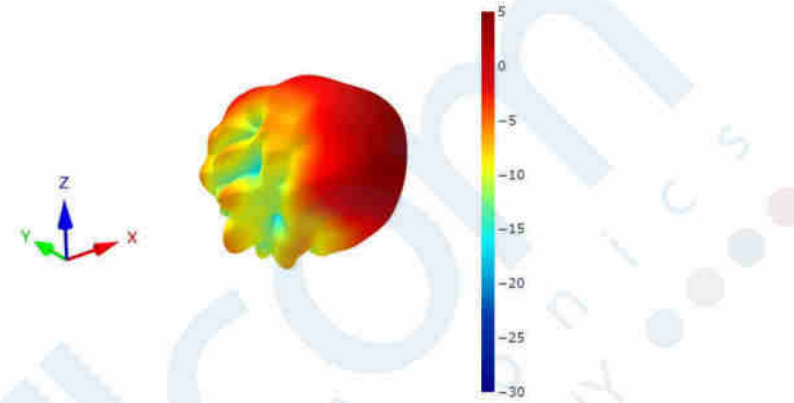
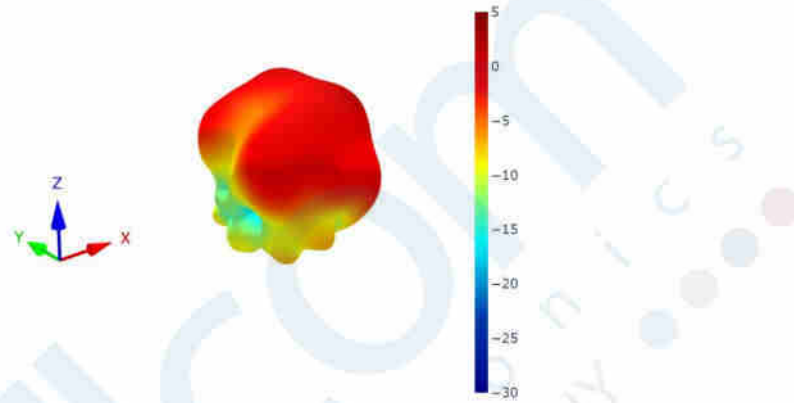

8.62 Cellular 3 Patterns at 2360 MHz

8.43 Cellular 8 Patterns at 1805 MHz

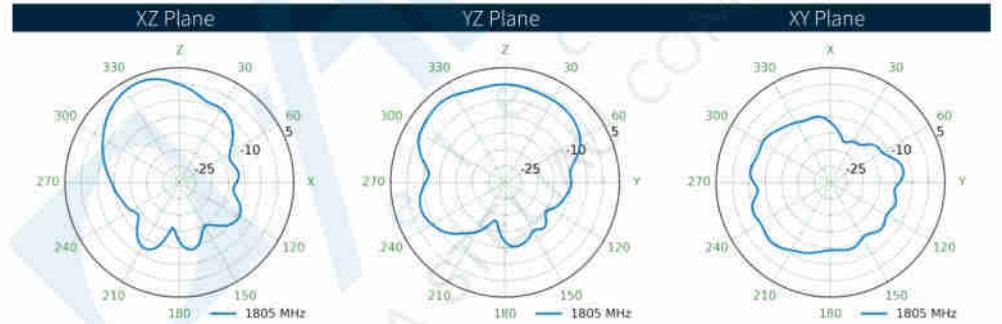
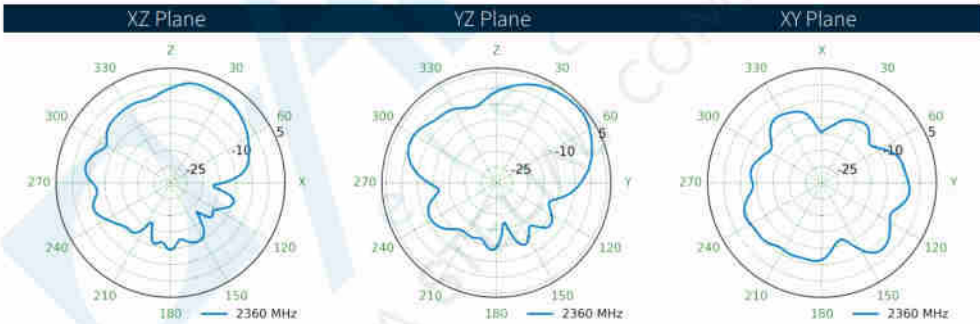
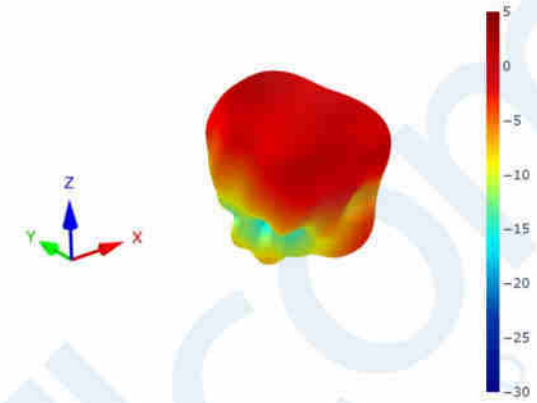
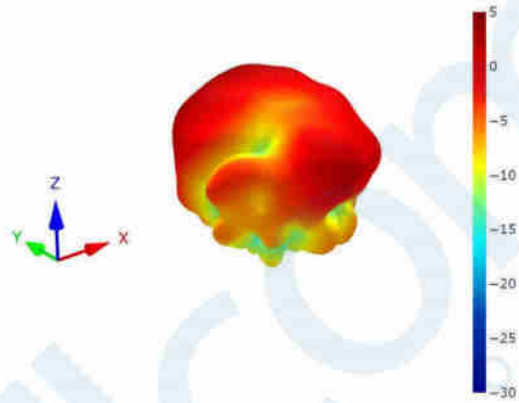

8.44 Cellular 1 Patterns at 1920 MHz

8.61 Cellular 2 Patterns at 2360 MHz

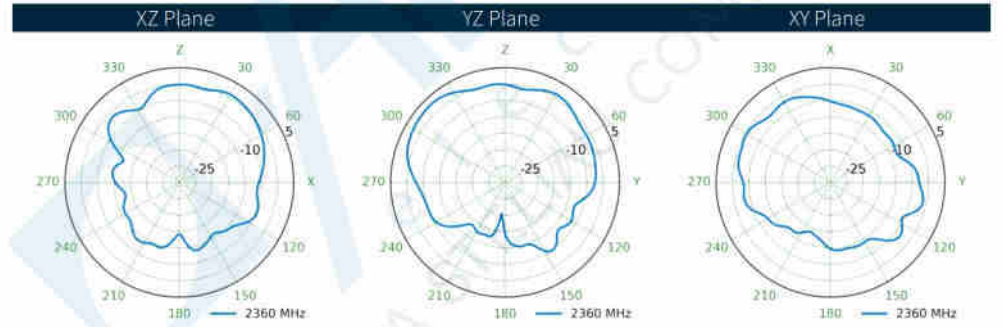
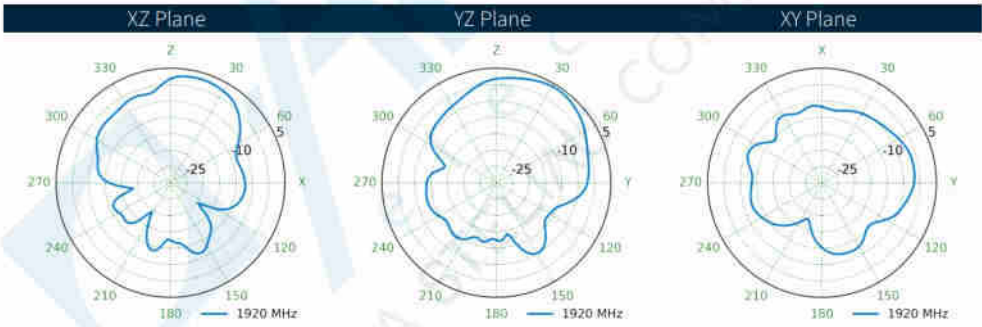
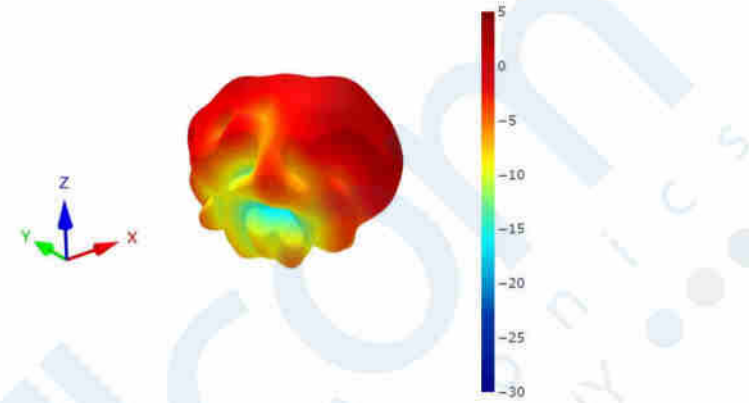
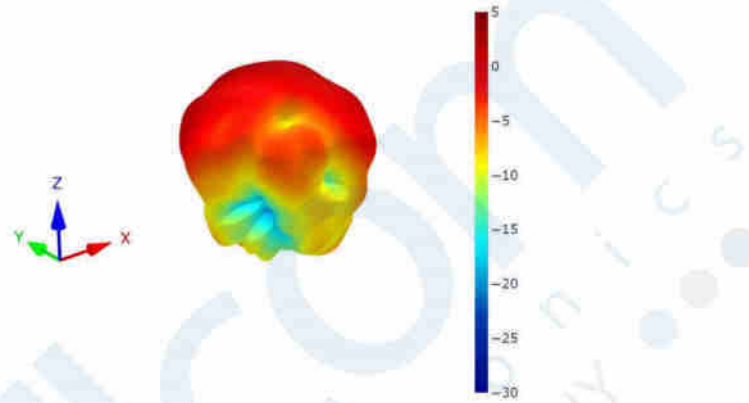

8.60 Cellular 1 Patterns at 2360 MHz

8.45 Cellular 2 Patterns at 1920 MHz

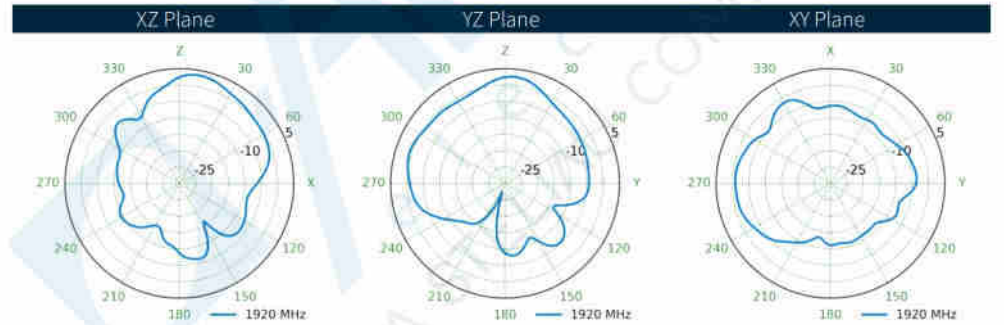
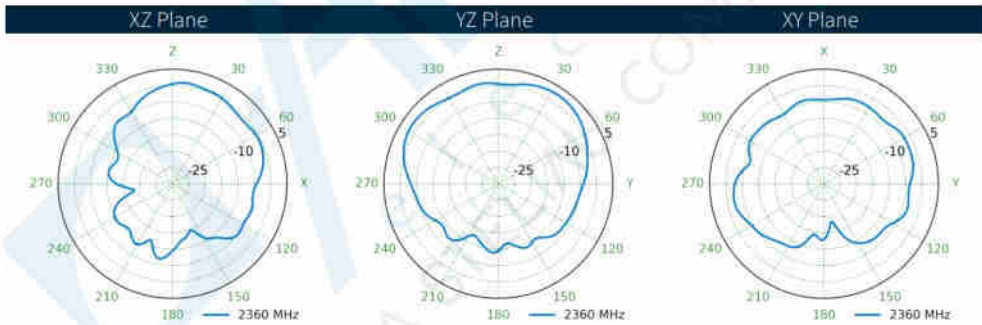
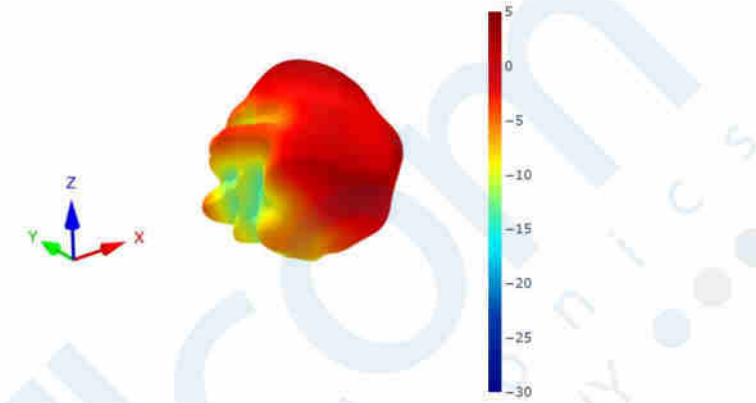
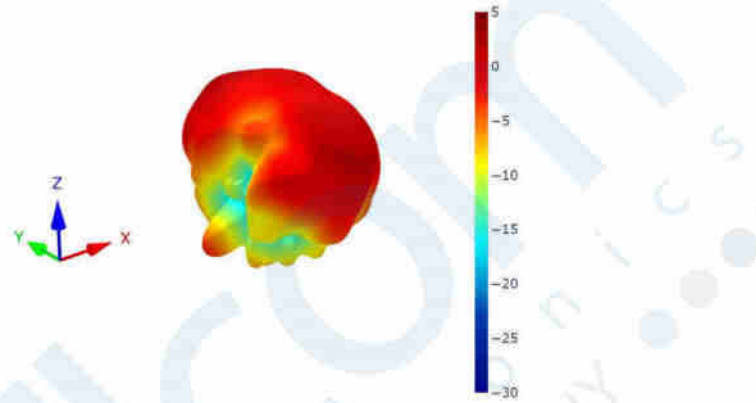

8.46 Cellular 3 Patterns at 1920 MHz

8.59 Cellular 8 Patterns at 1990 MHz

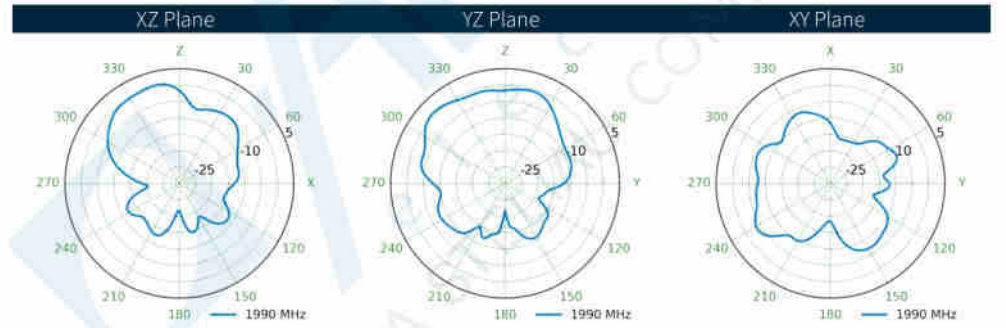
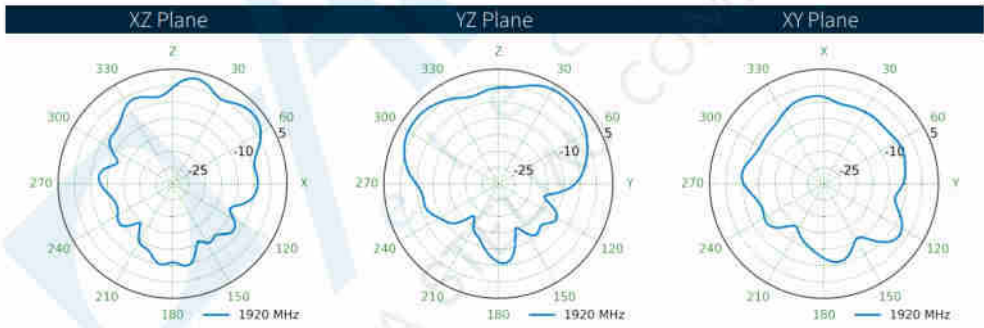
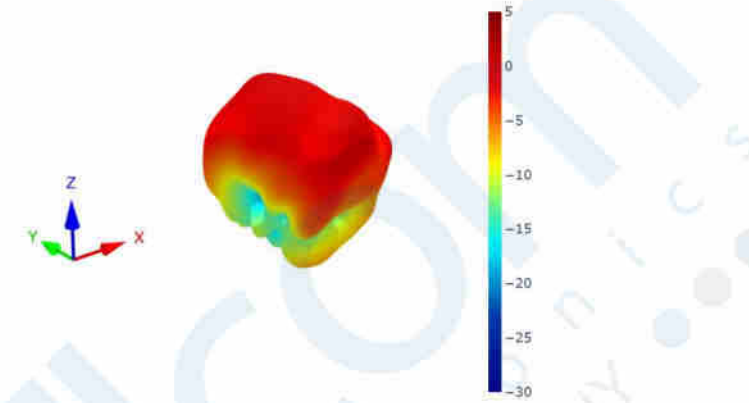
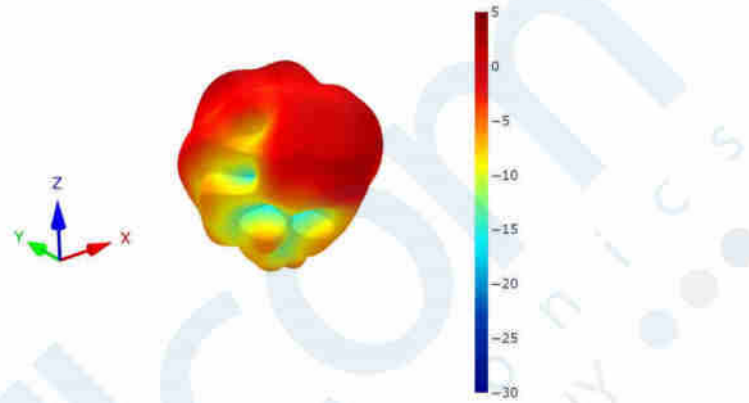

8.58 Cellular 7 Patterns at 1990 MHz

8.47 Cellular 4 Patterns at 1920 MHz

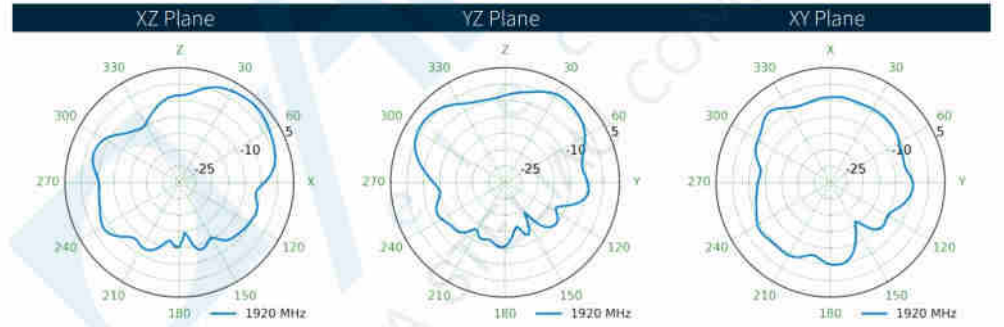
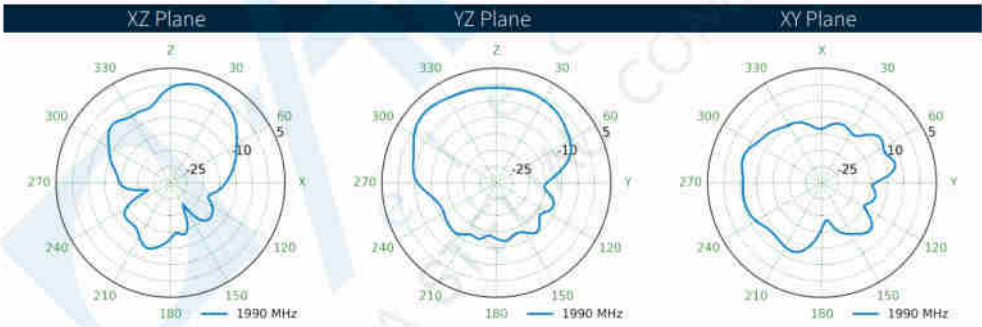
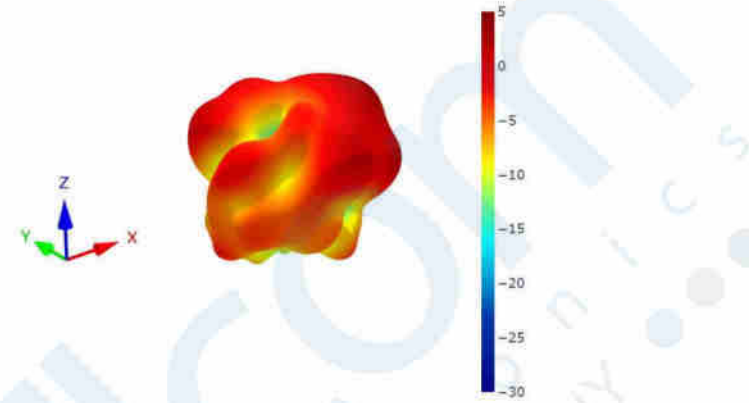
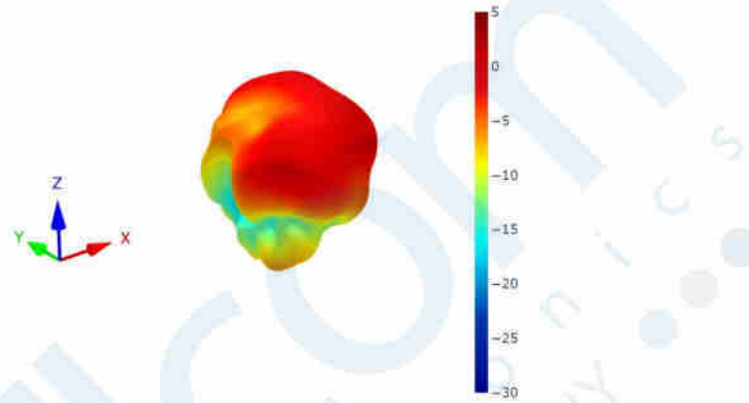

8.48 Cellular 5 Patterns at 1920 MHz

8.57 Cellular 6 Patterns at 1990 MHz

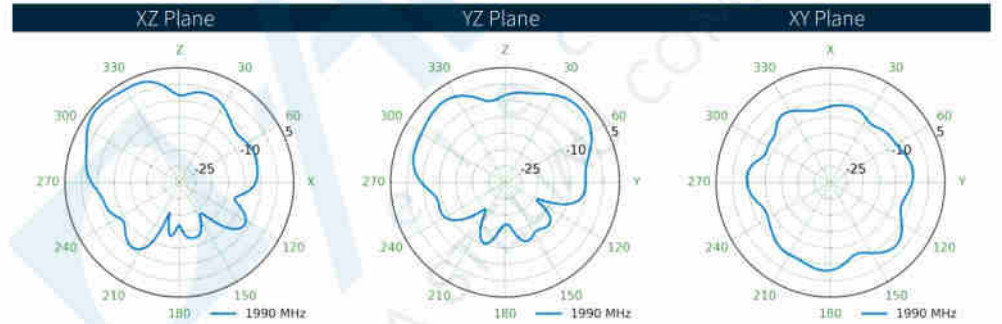
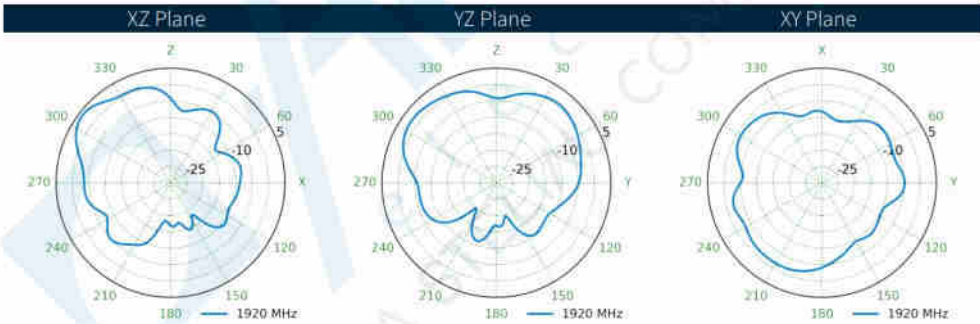
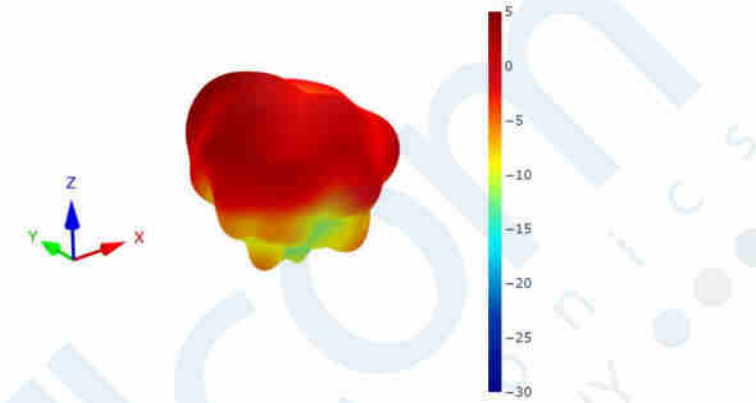
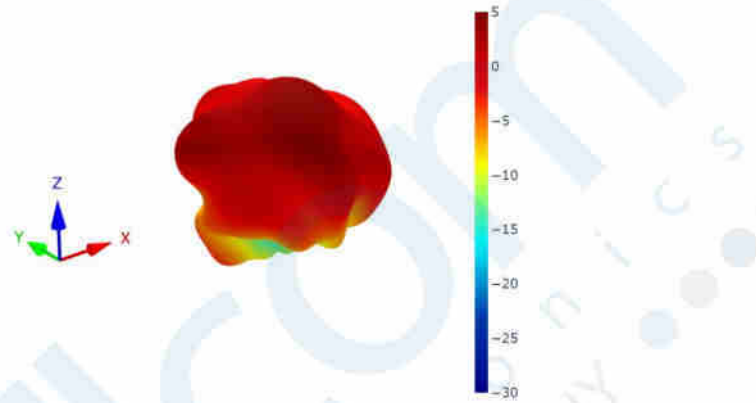

8.56 Cellular 5 Patterns at 1990 MHz

8.49 Cellular 6 Patterns at 1920 MHz

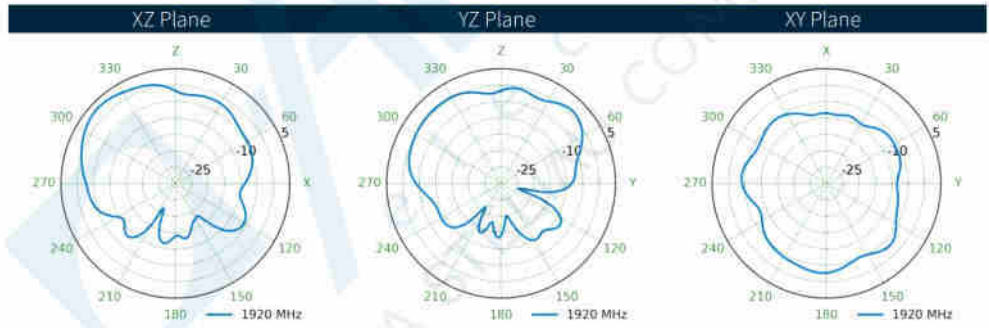
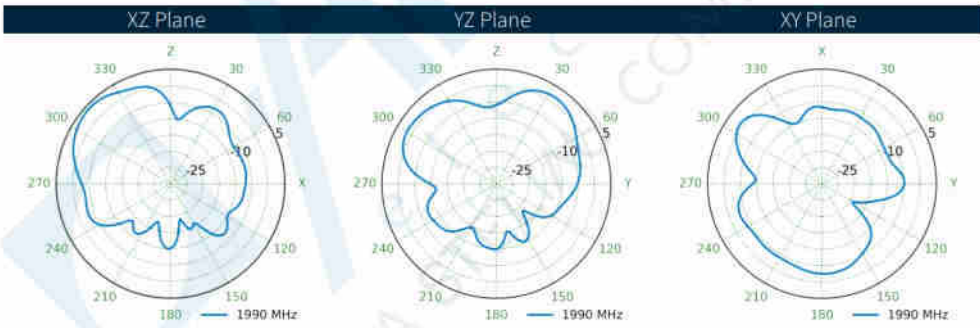
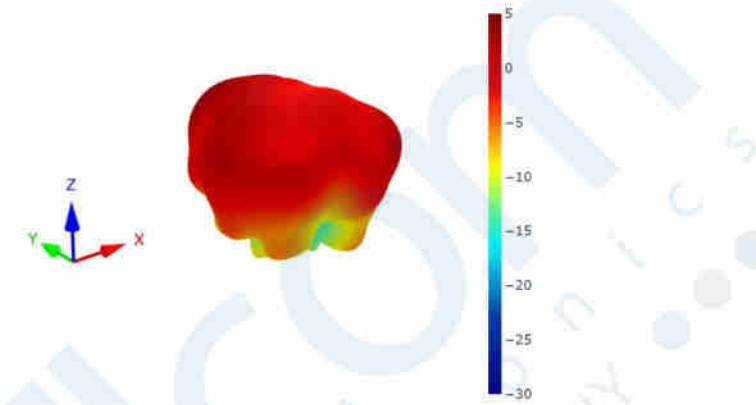
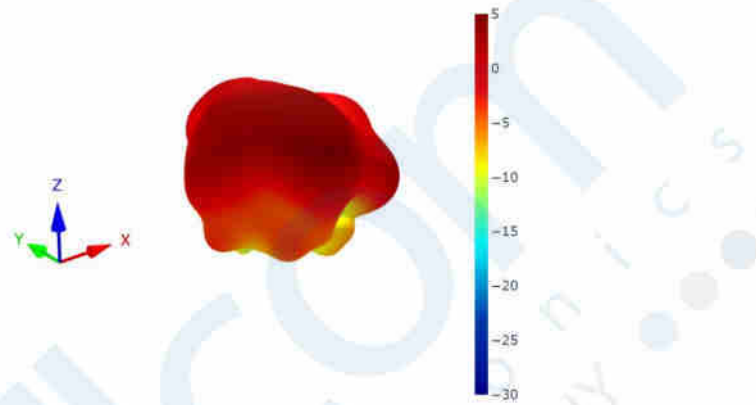

8.50 Cellular 7 Patterns at 1920 MHz

8.55 Cellular 4 Patterns at 1990 MHz

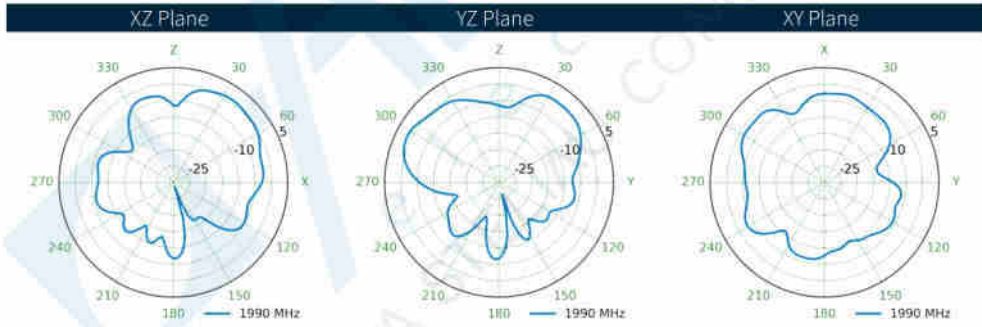
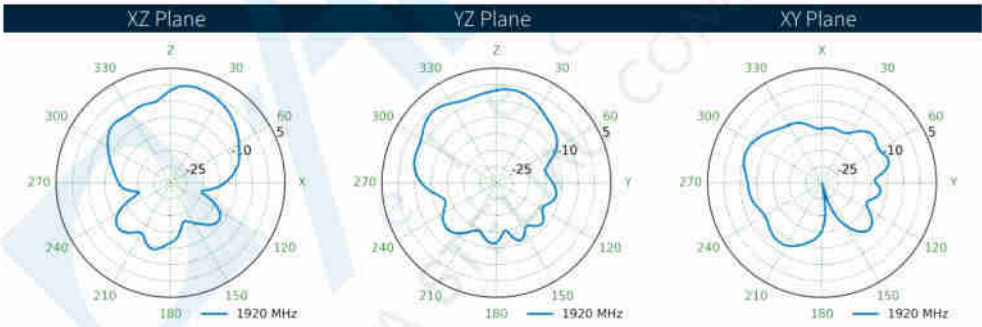
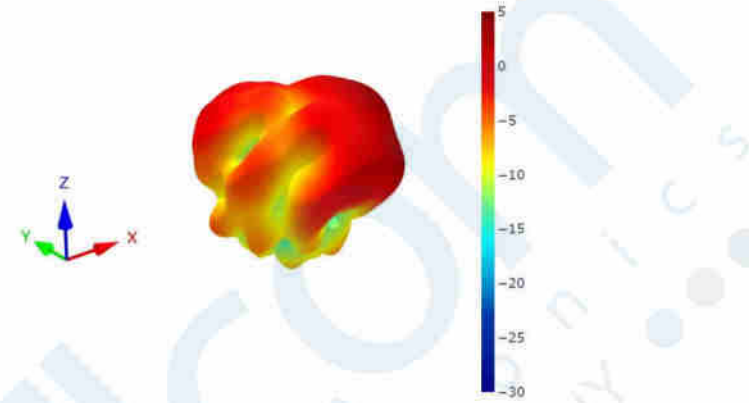
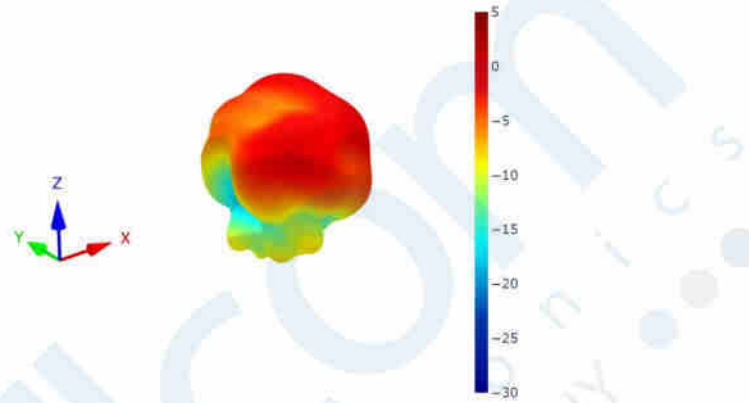

8.54 Cellular 3 Patterns at 1990 MHz

8.51 Cellular 8 Patterns at 1920 MHz

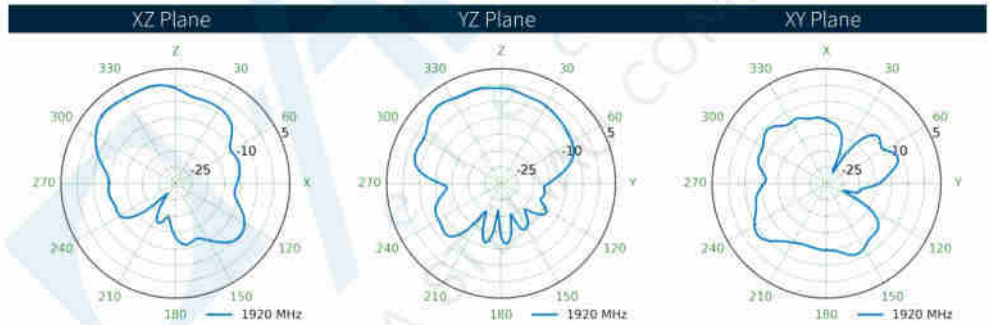
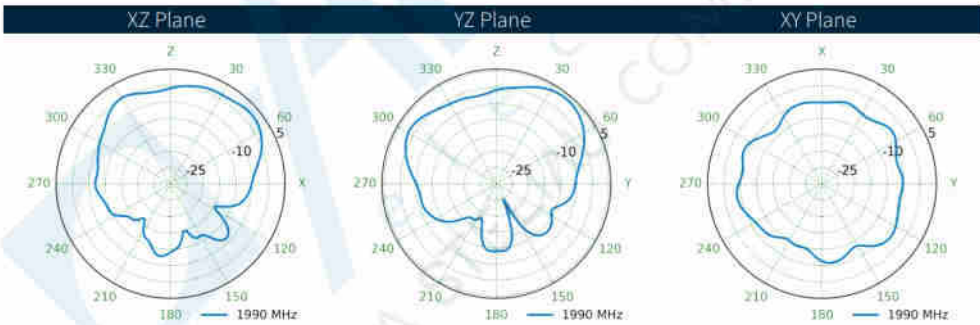
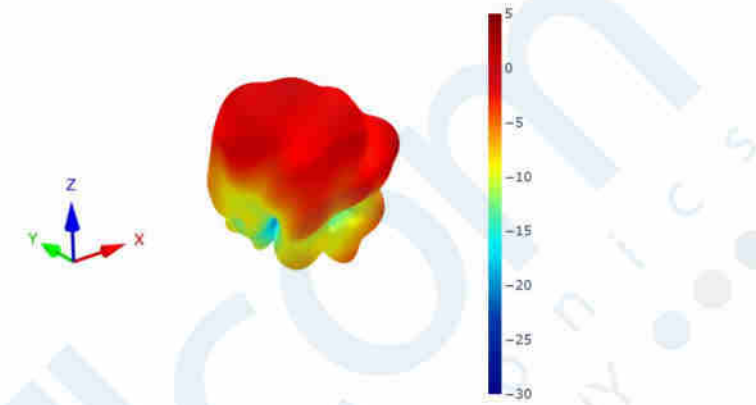
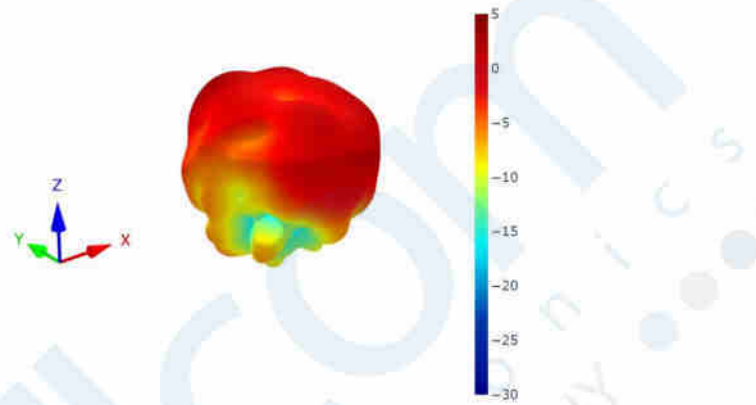

8.52 Cellular 1 Patterns at 1990 MHz

8.53 Cellular 2 Patterns at 1990 MHz

