

MANUALE D'USO STRIP LED DOT FREE P TYPE

STRIP LED DOT FREE MANUAL USER

P

Type

EMISSIONE VERSO L'ALTO SUPERFICIE QUADRATA

TOP EMITTING FOURSQUARE SURFACE



 Superficie quadrata, illuminazione con effetto continuo, zona d'aria incavata all'interno della struttura, buona dissipazione del calore.

 *Foursquare structure surface, dot-free illumination, hollow air layer inside design, good heat dissipation.*

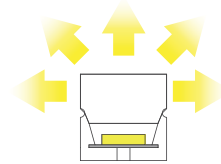

Angolo di apertura di 150°.
Illuminazione con effetto continuo

150° beam angle.
Dot-free illumination

Caratteristiche del prodotto / Product Features:

- Angolo di apertura 150°. Emissione su 3 lati
- Buona Visibilità
- IP65/67 Impermeabile
- 7 LED per unità con effetto continuo
- Silicone a doppio colore
- Zona d'aria incavata per una buona dissipazione del calore

- *150° Beam angle. 3 Side Emitting*
- *Good Visibility*
- *IP65/67 Waterproof*
- *7 LEDs per unit Dot-free*
- *Dual color of silicone*
- *Hollow air layer for good heat dissipation*

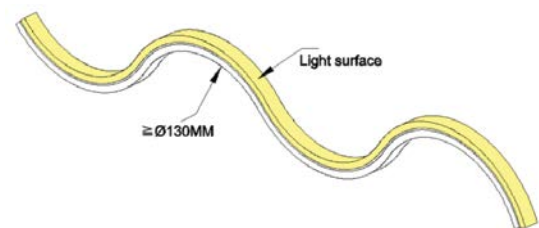

Applicazioni / Applications:



Silicone

ANGOLO DI APERTURA DA 150° E PROTEZIONE SPESSA

150° BEAM ANGLE & THICK PROTECTION

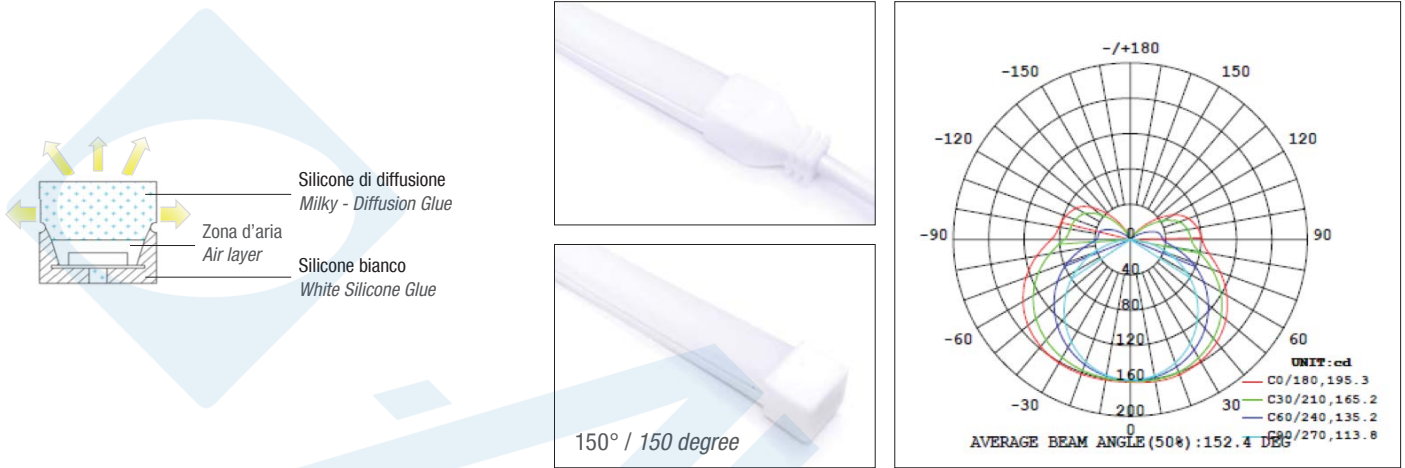

Rivestimento in silicone, resistente ai raggi UV, resistente all'ingiallimento, resistente alla fiamma. Include versioni a tensione costante 5M e corrente costante 10M.



Silicone coating, UV Resistant, Yellowing Resistant, Flame Resistant. Include 5M constant voltage and 10M constant current versions.

VISIBILITÀ E FLESSIBILITÀ

VISIBILITY & FLEXIBILITY

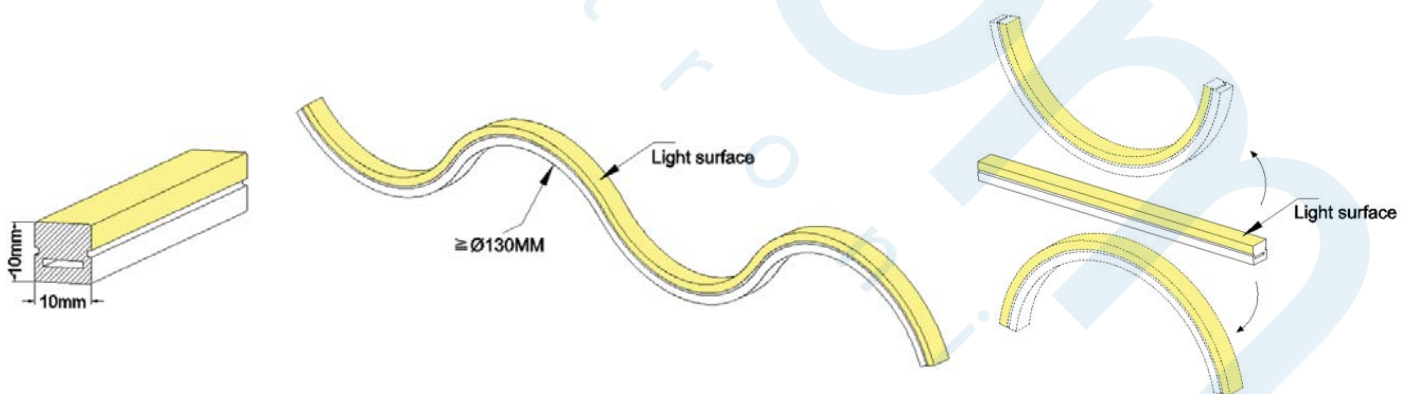

Emissione verso l'alto, curvabile in direzione verticale e con diametro di curvatura superiore a 130mm.



Top emitting, bendable direction vertically and minimum bending diameter for 130mm.

NUOVA STRUTTURA FPC

NEW FPC STRUCTURE



NEW! 7 LED per unità / 7 LEDs Per unit



7 LED per striscia, utilizzati come fonte di illuminazione, maggiore luminosità rispetto alle normali strisce Neon Flex.



7 LEDs per unit LED strip used as lighting source, higher lumen output than general Neon Flex.

DIMENSIONI

DIMENSION

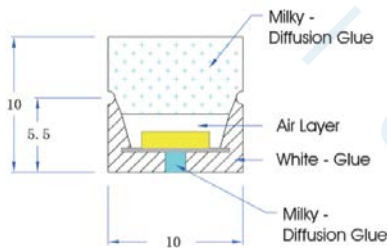

Dimensioni della striscia:
Strip dimension:
H 10mm X W 10mm

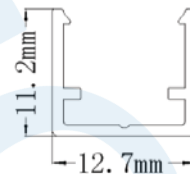

Dimensioni del clip di fissaggio:
Mounting clip dimension:
H 12,7mm X W 11,2mm

TAPPO ANTERIORE E DI CHIUSURA SAGOMATI CON STAMPAGGIO A DOPPIA INIEZIONE IP67

IP67 DUAL INJECTION-MOULDED FRONT CAP AND END CAP



Tappo anteriore/posteriore e cavo (IP67)
Front /End Cap & Cable (IP67)

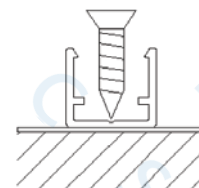

Clip difissaggio
Mounting Clip



Set completo di accessori per l'installazione. (tappo anteriore/posteriore, clip di fissaggio e cavo). Taglio e collegamento semplificati.



Full set of installation accessories. (front-end cap, mounting clip and cable). Easy cutting and connection.

PROCESSO DI INSTALLAZIONE

INSTALLATION PROCESS

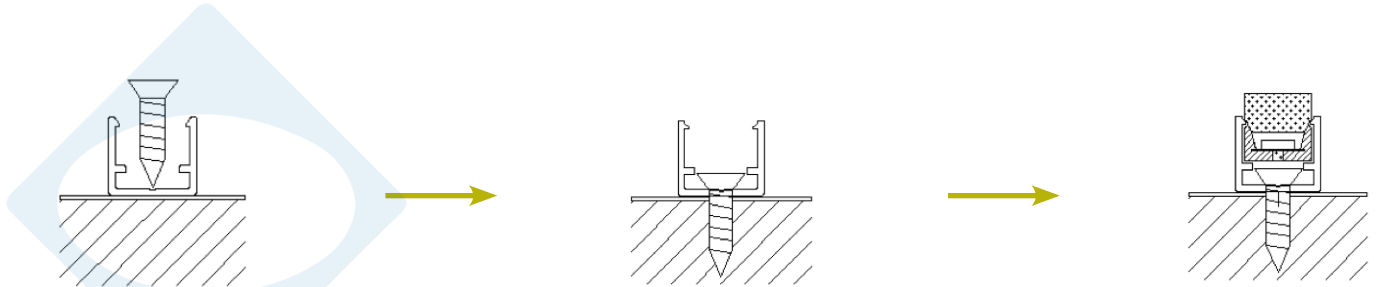

Fase 1. Posizionare il profilo plastico in plastica nel punto in cui dovrà essere installata la striscia LED.

Step 1. Put the plastic clip to the installation location.

Fase 2. Utilizzare un avvitatore per fissare il profilo plastico alla superficie.

Step 2. Use the electric screw driver to fix the plastic clip onto the surface.

Fase 3. Inserire delicatamente la striscia LED neon nel profilo plastico.

Step 3. Insert the Neon LED strip into the plastic clip softly.

SCHEMA ELETTRICO

CIRCUIT DIAGRAM

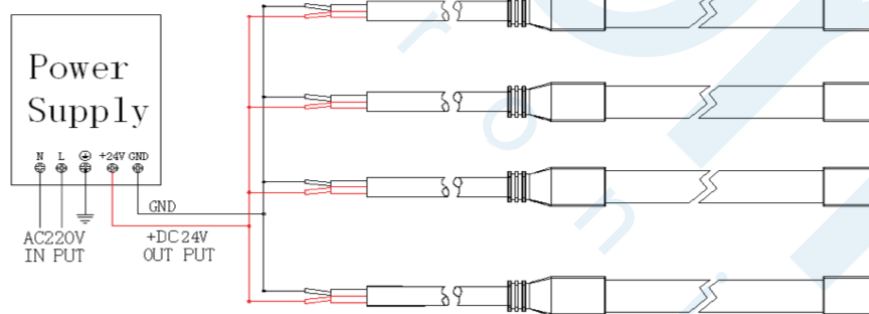

PROFILO IN ALLUMINIO

ALUMINUM PROFILE

Installazione profilo in alluminio come accessorio opzionale, le viti possono essere ordinate secondo necessità.

Installation aluminum profile as optional accessory, screws can be ordered as needed.

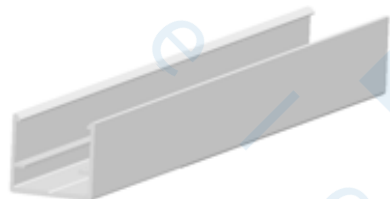
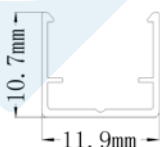

PROCEDURE DI CONNESSIONE

CONNECTING PROCEDURE

1) Installazione connettore Strip-to-Wire / *Strip-to-Wire connector installation:*

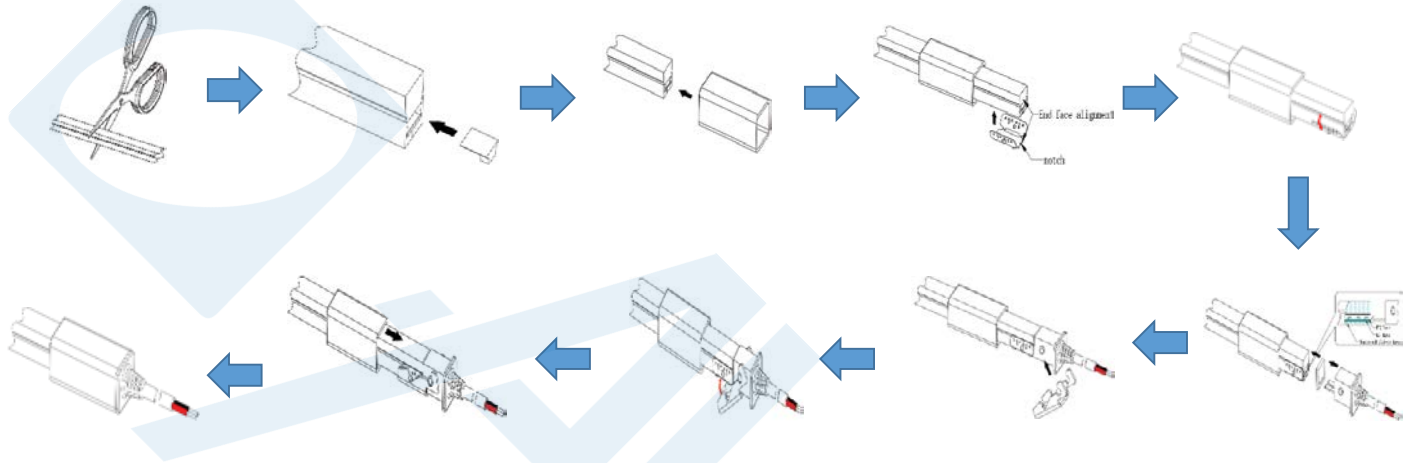

2) Installazione connettore Strip-to-Strip / *Strip-to-Strip connector installation:*

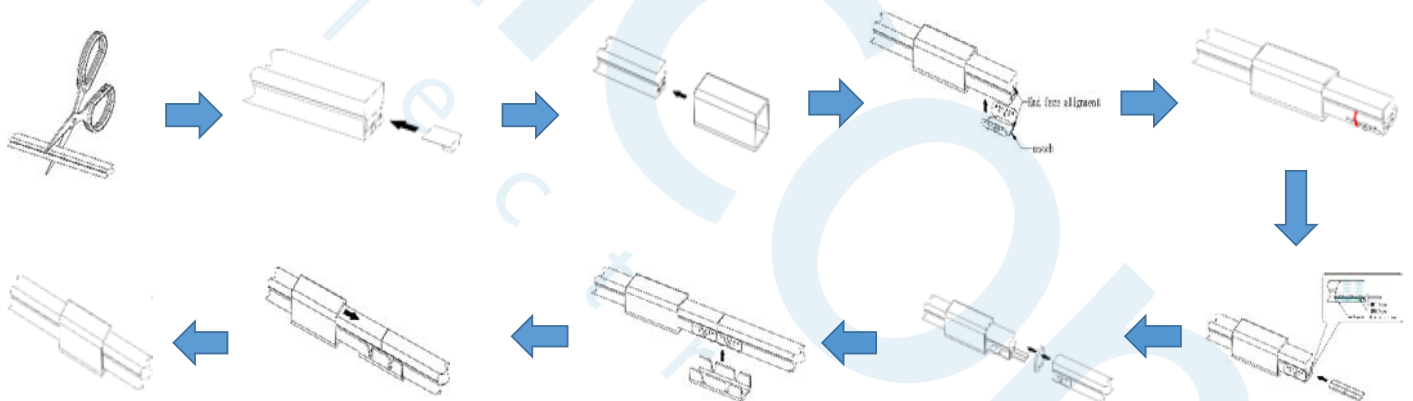

3) Installazione finale End-Cap / *End-Cap installation:*

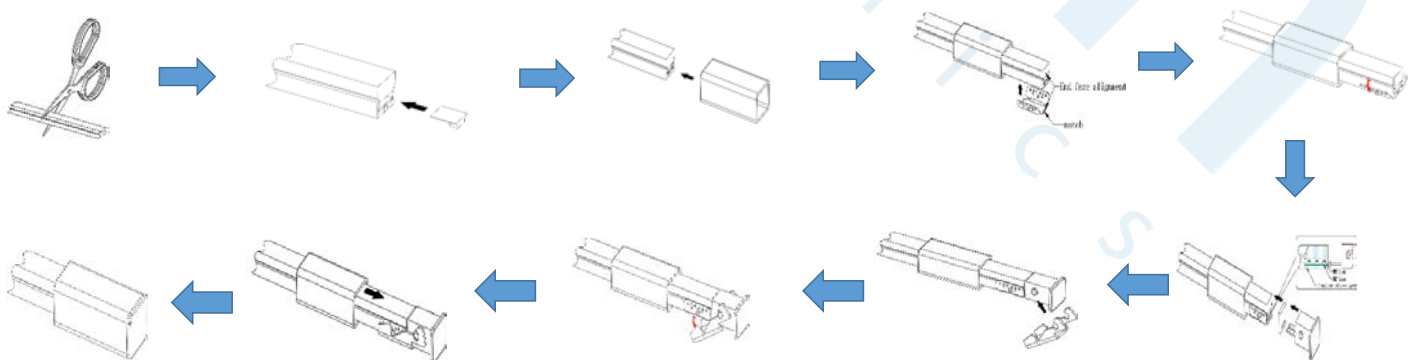

PROCESSO DI TAGLIO E COLLEGAMENTO

EASY SELF-CUTTING AND CONNECTION PROCESS



Fase 1. Individuare il punto di taglio riportato sulla striscia.
Step 1. Find the cutting line mark.



Fase 2. Separare la striscia tagliandola nel punto di taglio indicato.
Step 2. Split the strip along the cutting mark by knife.

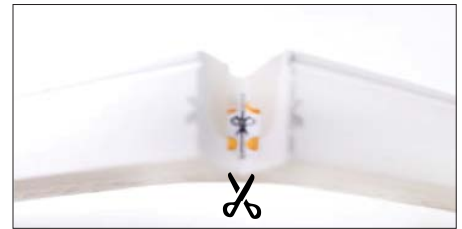

Fase 3. Tagliare, servendosi di forbici, il PCB all'interno della striscia, lungo la linea di tratteggio indicata.
Step 3. Cut the PCB along the cutting mark inside the strip by scissors.

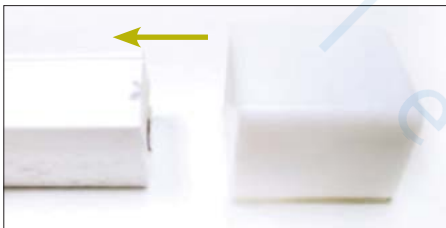

Fase 4. Fissare l'estremità finale della striscia con il tappo di chiusura.
Step 4. Fix the strip end into end cap.



Fase 5. Saldare il cavo sul PCB e unire la parte anteriore della striscia con il tappo anteriore.
Step 5. Solder the cable onto PCB and connect the strip front and front cap.



Fase 6. Utilizzare del silicone per bloccare il tappo di chiusura e quello anteriore.
Step 6. Use silicone glue to adhere end cap and front cap.

ACCESSORI STRIP LED DOT FREE

STRIP LED DOT FREE ACCESSORIES

"P" Type

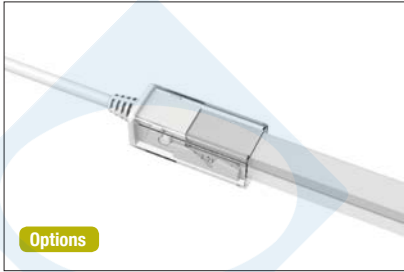

Dot Free Type "P" 10mm Strip To Wire Connector
3ILDFPSTWC10



Dot Free Type "P" 10mm End Cap Connector
3ILDPECC10

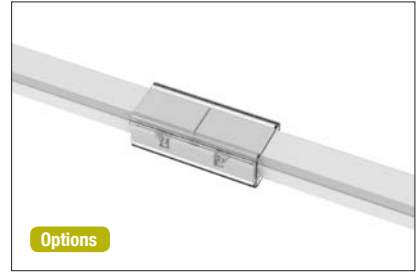

Dot Free Type "P" Strip To Strip Connector
3ILDFPSTSC10

Profili - Profile



Moldable Profile
10mm "P" Type 3ILPLG1110-500 _ 5000mm Lenght

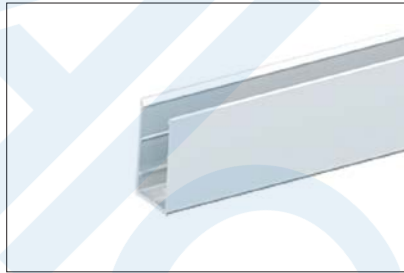

Aluminum Profile
10mm "P" Type 3ILAP1211-100 _ 1000mm Lenght



PC Mounting Clip
10mm "P" Type 3ILPC1212-0025 _ 25mm Lenght