

Features

- Full Power at Wide Output Current Range (Constant Power)
- Adjustable Output Current (AOC) with NFC
- Isolated 1-10V/3-Timer-Modes Dimmable
- Output Lumen Compensation
- End-of-Life Indicator
- Long Lifetime Over 100K Hours at 75°C Case Temperature
- Input Surge Protection: DM 6 kV, CM 10 kV
- All-Around Protection: OVP, SCP, OTP
- IP20 Design and Suitable for Outdoor Applications in Luminaires with IP>54
- SELV Output
- Suitable for Luminaires with Protection Class I and II
- Complies with Zhaga Interface Specification Book 13
- 8 Years Warranty



Description

The EBS-040SxxxDT2 series is a 40W, constant-current, NFC programmable and IP20 rated LED driver that operates from 176-305 Vac input with excellent power factor. It was created for many lighting applications including street, tunnel and low bay, etc. The high efficiency of these drivers and better thermal design enable them to run cooler, significantly improving reliability and extending product life. To ensure trouble-free operation, protection is provided against input surge, output over voltage, short circuit, and over temperature.

Models

Adjustable Output Current Range	Full-Power Current Range (1)	Default Output Current	Input Voltage Range(2)	Output Voltage Range	Max. Output Power	Typical Efficiency (3)	Typical Power Factor (3)	Model Number
30-450 mA	300-450 mA	450 mA	176~305 Vac 171~275 Vdc	44~133 Vdc	40 W	90.5%	0.96	EBS-040S045DT2
45-700 mA	450-700 mA	700 mA	176~305 Vac 171~275 Vdc	28 ~ 89 Vdc	40 W	89.0%	0.96	EBS-040S070DT2 ⁽⁴⁾
70-1050mA	700-1050 mA	1050 mA	176~305 Vac 171~275 Vdc	19 ~ 57Vdc	40 W	89.5%	0.96	EBS-040S105DT2 ⁽⁴⁾

Notes: (1) Output current range with constant power at 40W

(2) CCC certified input voltage range: 220-240Vac; otherwise: 200-240Vac

(3) Measured at 100% load and 220Vac input (see below "General Specifications" for details).

(4) SELV Output.

I-V Operating Area

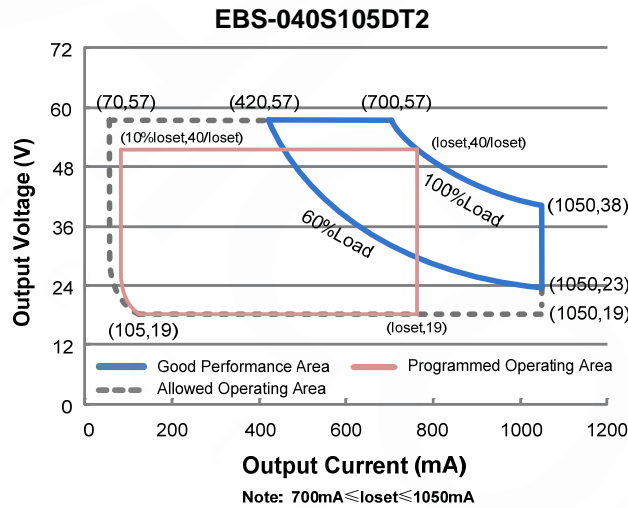
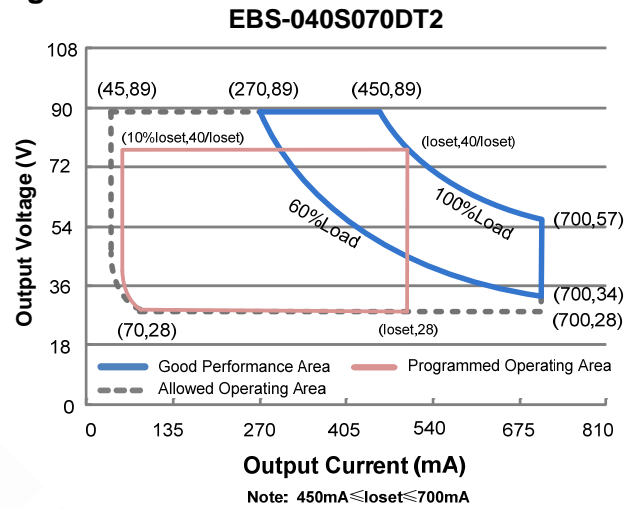
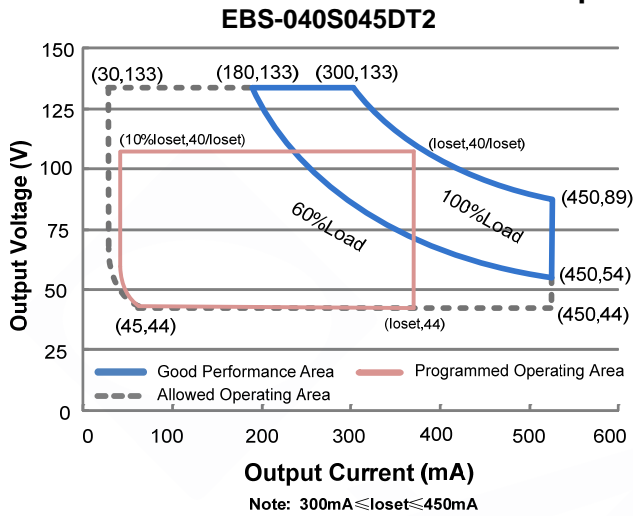

Input Specifications

Parameter	Min.	Typ.	Max.	Notes
Input AC Voltage	176 Vac	-	305 Vac	
Input DC Voltage	171 Vdc	-	275 Vdc	
Input Frequency	47 Hz	-	63 Hz	
Leakage Current	-	-	0.70 mA	IEC60598-1; 240Vac/ 60Hz
Input AC Current	-	-	0.23 A	Measured at 100% load and 220 Vac input.
Inrush Current(I^2t)	-	-	0.82 A ² s	At 220Vac input, 25°C Cold Start, Duration =440 μs, 10%Ipk-10%Ipk. See Inrush Current Waveform for the details.

Input Specifications (Continued)

Parameter	Min.	Typ.	Max.	Notes
PF	0.90	-	-	At 200-240Vac, 50-60Hz, 60%-100% Load (24-40W)
THD	-	-	20%	
THD	-	-	10%	At 220-240Vac, 50-60Hz, 70%-100% Load (28-40W)

Output Specifications

Parameter	Min.	Typ.	Max.	Notes
Output Current Tolerance	-5%loset	-	5%loset	At 100% load condition
Output Current Setting(loset) Range				
EBS-040S045DT2	30 mA	-	450 mA	
EBS-040S070DT2	45 mA	-	700 mA	
EBS-040S105DT2	70 mA	-	1050 mA	
Output Current Setting Range with Constant Power				
EBS-040S045DT2	300 mA	-	450 mA	
EBS-040S070DT2	450 mA	-	700 mA	
EBS-040S105DT2	700 mA	-	1050 mA	
Total Output Current Ripple (pk-pk)	-	5%lomax	10%lomax	At 100% load condition, 20 MHz BW
Output Current Ripple at < 200 Hz (pk-pk)	-	2%lomax	-	At 100% load condition. Only this component of ripple is associated with visible flicker.
Startup Overshoot Current	-	-	10%lomax	At 100% load condition
No Load Output Voltage				
EBS-040S045DT2	-	-	170 V	
EBS-040S070DT2	-	-	115 V	
EBS-040S105DT2	-	-	75 V	
Line Regulation	-	-	±1%	Measured at 100% load
Load Regulation	-	-	±5%	
Turn-on Delay Time	-	-	0.5 s	Measured at 200-240Vac input, 60%-100% Load
Temperature Coefficient of loiset	-	0.06%/°C	-	Case temperature = 0°C ~Tc max

General Specifications

Parameter	Min.	Typ.	Max.	Notes
Efficiency at 220 Vac input:				
EBS-040S045DT2				Measured at 100% load and steady-state temperature in 25°C ambient; (Efficiency will be about 2.0% lower if measured immediately after startup.)
Io= 300 mA	88.0%	90.0%	-	
Io= 450 mA	88.5%	90.5%	-	
EBS-040S070DT2				
Io= 450 mA	86.5%	88.5%	-	
Io= 700 mA	87.0%	89.0%	-	
EBS-040S105DT2				
Io= 700 mA	87.0%	89.0%	-	
Io= 1050 mA	87.5%	89.5%	-	

General Specifications (Continued)

Parameter	Min.	Typ.	Max.	Notes
MTBF	-	501,000 hours	-	Measured at 220Vac input, 80% Load and 25°C ambient temperature (MIL-HDBK-217F)
Lifetime	-	104,000 hours	-	Measured at 220Vac input, 80%Load and 75°C case temperature; See lifetime vs. Tc curve for the details
Operating Case Temperature for Safety Tc_s	-40°C	-	+90°C	
Operating Case Temperature for Warranty Tc_w	-40°C	-	+75°C	Case temperature for 8 years warranty. Please see Inventronics Warranty Statement for complete details. Humidity: 10% RH to 90% RH; No condensation
Storage Temperature	-40°C	-	+85°C	Humidity: 5% RH to 95% RH; No condensation
Dimensions Inches (L x W x H) Millimeters (L x W xH)	5.24 x 3.03 x 1.30 133 x 77 x 33			
Net Weight	-	230 g	-	

Dimming Specifications

Parameter	Min.	Typ.	Max.	Notes	
Absolute Maximum Voltage on the Vdim (+) Pin	-20 V	-	20 V		
Source Current on Vdim (+)Pin	200 uA	300 uA	450 uA	Vdim(+) = 0 V	
Dimming Output Range	EBS-040S045DT2 EBS-040S070DT2 EBS-040S105DT2	10%loset	-	loset	300 mA ≤ loset ≤ 450 mA 450 mA ≤ loset ≤ 700 mA 700 mA ≤ loset ≤ 1050 mA
	EBS-040S045DT2 EBS-040S070DT2 EBS-040S105DT2	30 mA 45 mA 70 mA	-	loset	30 mA ≤ loset < 300 mA 45 mA ≤ loset < 450 mA 70 mA ≤ loset < 700 mA
	Recommended Dimming Range for 1-10V	1 V	-	9 V	Default 1-10V dimming mode with positive logic.

Safety &EMC Compliance

Safety Category	Standard
ENEC & CE	EN 61347-1, EN 61347-2-13
CB	IEC 61347-1, IEC 61347-2-13
CCC	GB 19510.1, GB 19510.14
KS	KS C 7655
EMI Standards	Notes
EN 55015/GB 17743 ⁽¹⁾	Conducted emission Test &Radiated emission Test
EN 61000-3-2/GB 17625.1	Harmonic current emissions Class C
EN 61000-3-3	Voltage Fluctuations & Flicker

Safety & EMC Compliance (Continued)

EMS Standards	Notes
EN 61000-4-2	Electrostatic Discharge(ESD): 8 kV air discharge, 4 kV contact discharge
EN 61000-4-3	Radio-Frequency Electromagnetic Field Susceptibility Test-RS
EN 61000-4-4	Electrical Fast Transient/Burst-EFT
EN 61000-4-5	Surge Immunity Test: AC Power Line: Differential Mode 6 kV, Common Mode 8 kV
EN 61000-4-6	Conducted Radio Frequency Disturbances Test-CS
EN 61000-4-8	Power Frequency Magnetic Field Test
EN 61000-4-11	Voltage Dips
EN 61547	Surge Immunity Test: AC Power Line: Differential Mode 6 kV, Common Mode 10 kV
	Electromagnetic Immunity Requirements Applies to Lighting Equipment

Notes: (1) This LED driver meets the EMI specifications above, but EMI performance of a luminaire that contains it depends also on the other devices connected to the driver and on the fixture itself.

Lifetime vs. Case Temperature

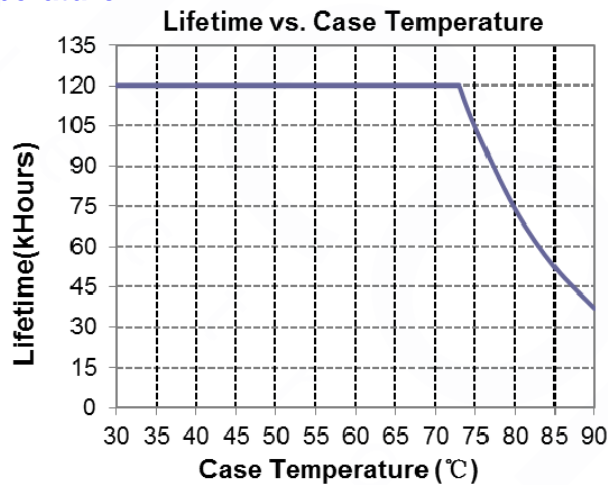

Inrush Current Waveform

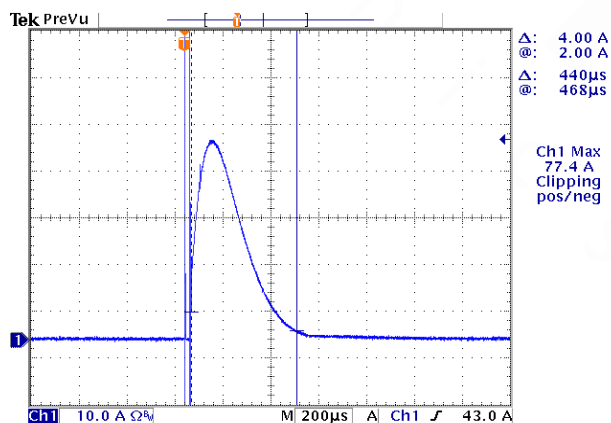

Efficiency vs. Load

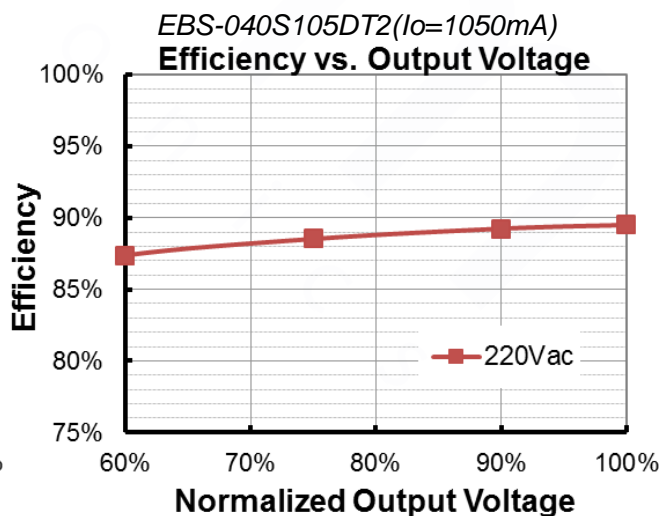
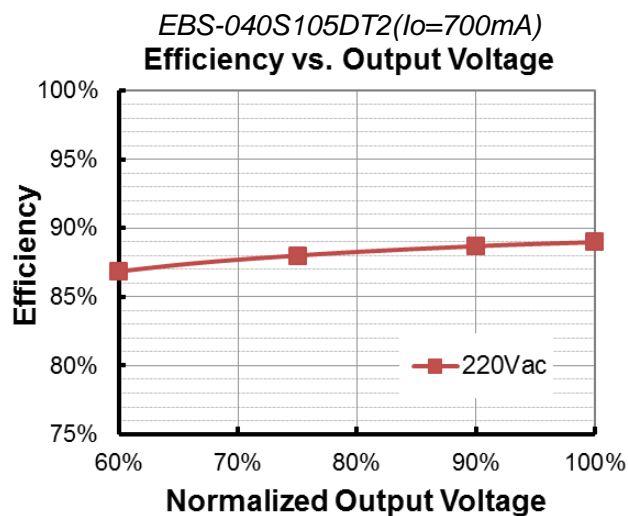
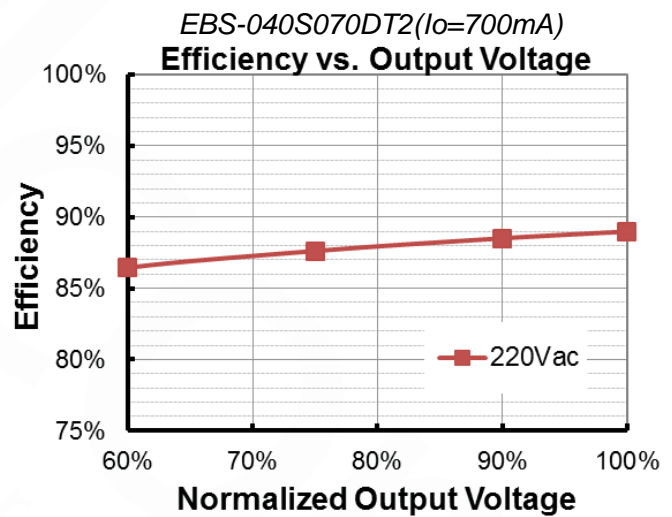
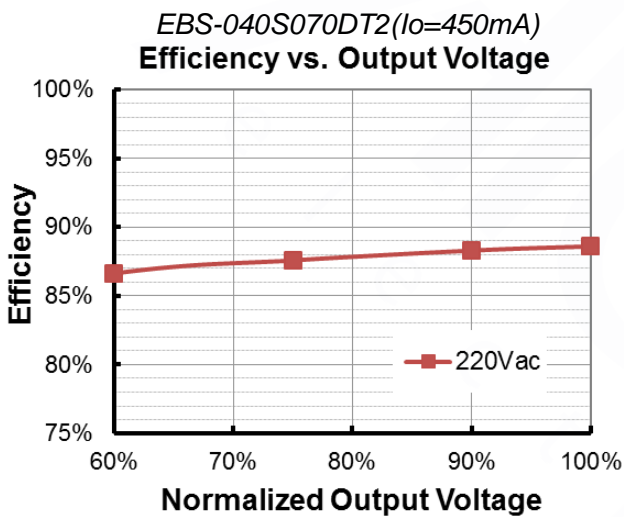
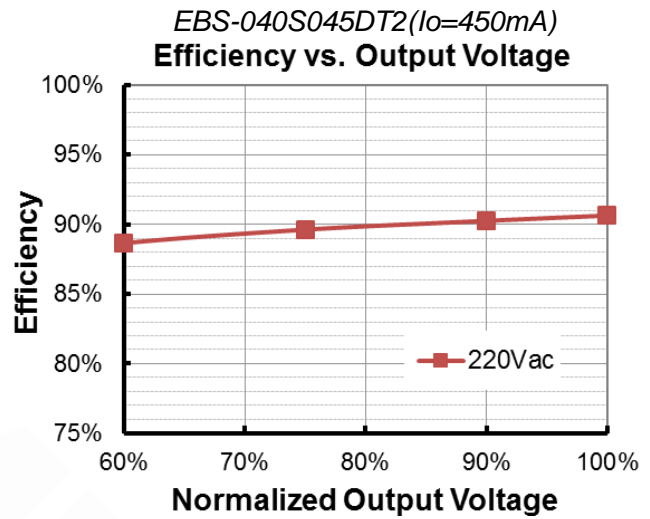
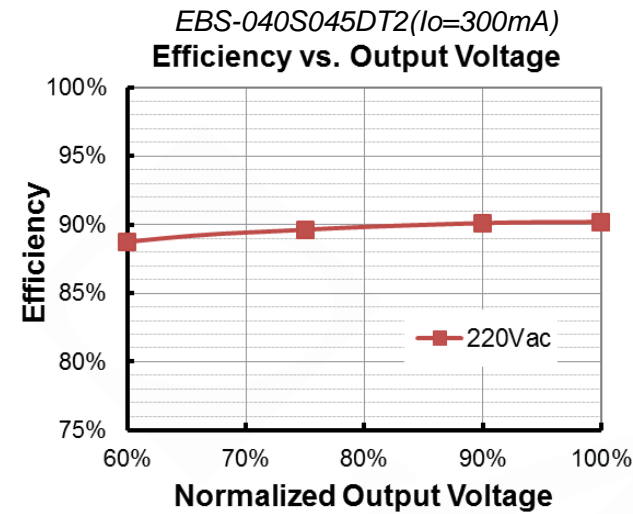

Power Factor

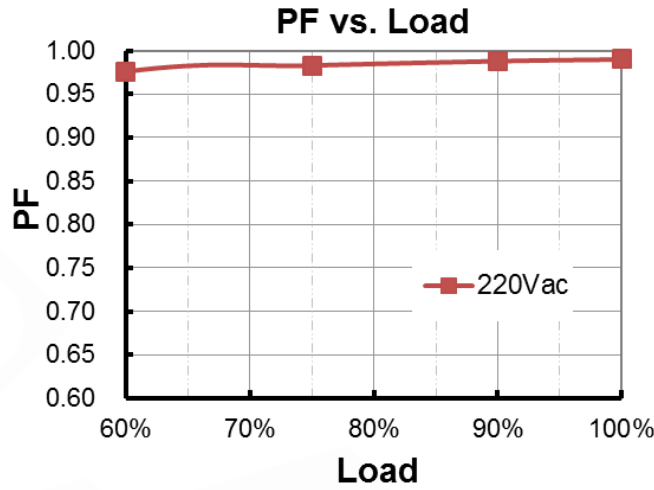

Total Harmonic Distortion

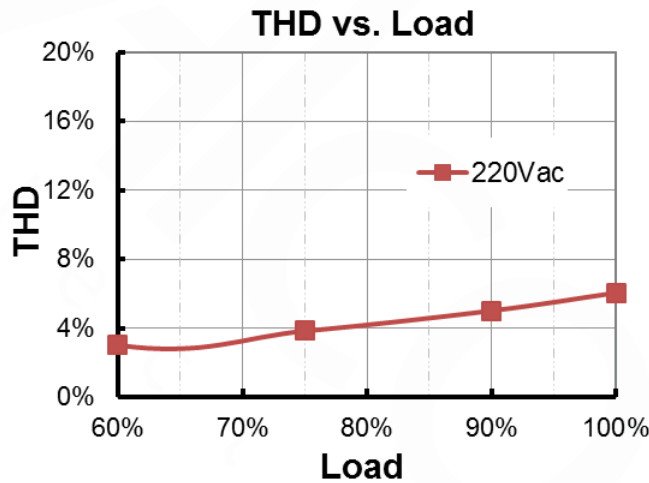

Protection Functions

Parameter	Min.	Typ.	Max.	Notes
Over Voltage Protection	Limits output voltage at no load and in case the normal voltage limit fails.			
Short Circuit Protection	Auto Recovery. No damage will occur when any output is short circuited. The output shall return to normal when the fault condition is removed.			
Over Temperature Protection	Decreases output current, returning to normal after over temperature is removed.			
Input Over Voltage Withstand	-	-	320 Vac	The driver can survive for 48 hours with input voltage stress of 320Vac.

Dimming

● 1-10V Dimming

The recommended implementation of the dimming control is provided below.

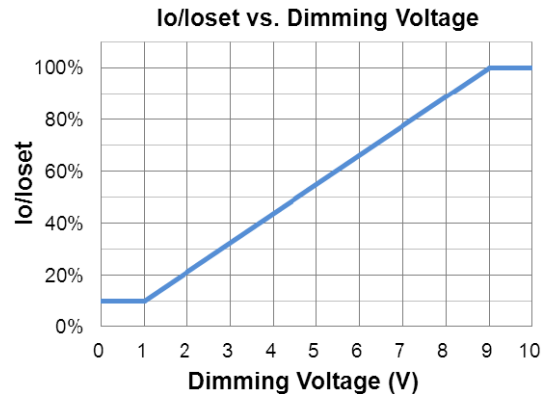
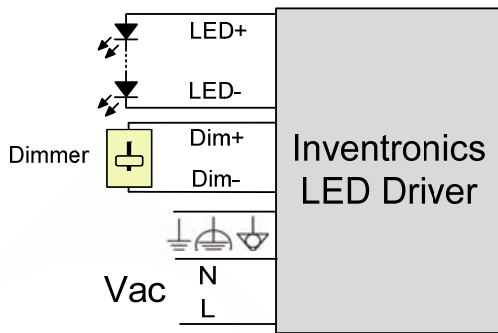

Implementation 1: Positive logic

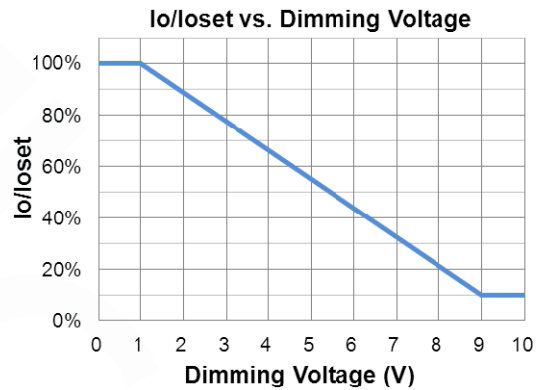
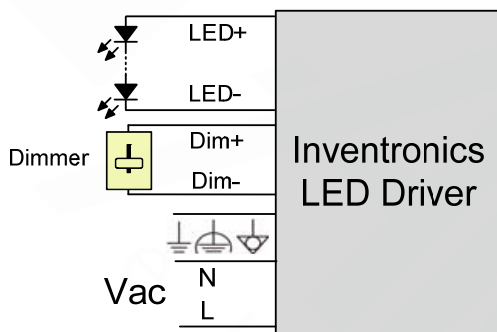

Implementation 2: Negative logic

Notes:

1. Do NOT connect Dim- to the output V- or V+, otherwise the driver will not work properly.
2. The dimmer can also be replaced by an active 1-10V voltage source signal or passive components like zener.
3. When 1-10V negative logic dimming mode and Dim+ is open, the driver will output minimum current.

● **Time Dimming**

Time dimming control includes 3 kinds of modes, they are Self Adapting-Midnight, Self Adapting-Percentage and Traditional Timer.

- **Self Adapting-Midnight:** Automatically adjusts the dimming curve based on the on-time of past two days (if difference <15 minutes), assuming that the center point of the dimming curve is midnight local time.
- **Self Adapting-Percentage:** Automatically adjusts the on-time of each step by a constant percentage = (actual on-time for the past 2 days if difference <15 min) / (programmed on-time from the dimming curve).
- **Traditional Timer:** Follows the programmed timing curve after power on with no changes.
- **Override Timer:** When the integrated timer is enabled, it is possible to override the dimming mode from 'Timer' into '1-10V' by applying a voltage of 1-10V between DIM+ and DIM-. Once a voltage ≤ 10.5 Vdc is detected the output current will coincide with the dimming voltage. By opening the DIM+ and DIM- circuitry, the LED driver will switch again to timer mode. During override, our product continues to count while the timer is being overridden. Once the override is removed, the output current returns to the same point in its timer cycle.

● **Output Lumen Compensation**

Output Lumen Compensation (OLC) may be used to maintain constant light output over the life of the LEDs by driving them at a reduced current when new, then gradually increasing the drive current over time to counteract LED lumen degradation.

● **End Of Life**

End-of-Life (EOL) is providing a visual notification to a user that the LED module has reached the end of manufacturer-specified life and that the replacement is recommended. Once active, an indication is given at each power-up of the driver, which the driver indicates this through a lower light output during the first 1 minute before normal operation is continued.

Wire Connection Diagram

Parameter		Min.	Typ.	Max.	Notes
L, N, 	Wire Cross-section	0.4 mm ²	-	1.5 mm ²	Push-in at 45° angle, solid and stranded wire
		20 AWG	-	16 AWG	
	Strip Length	8.5 mm	-	9.5 mm	
LED+, LED-, Dim+, Dim-	Wire Cross-section	0.2 mm ²	-	1.5 mm ²	Push-in at 45° angle, solid and stranded wire
		22 AWG	-	16 AWG	
	Strip Length	8.5 mm	-	9.5 mm	

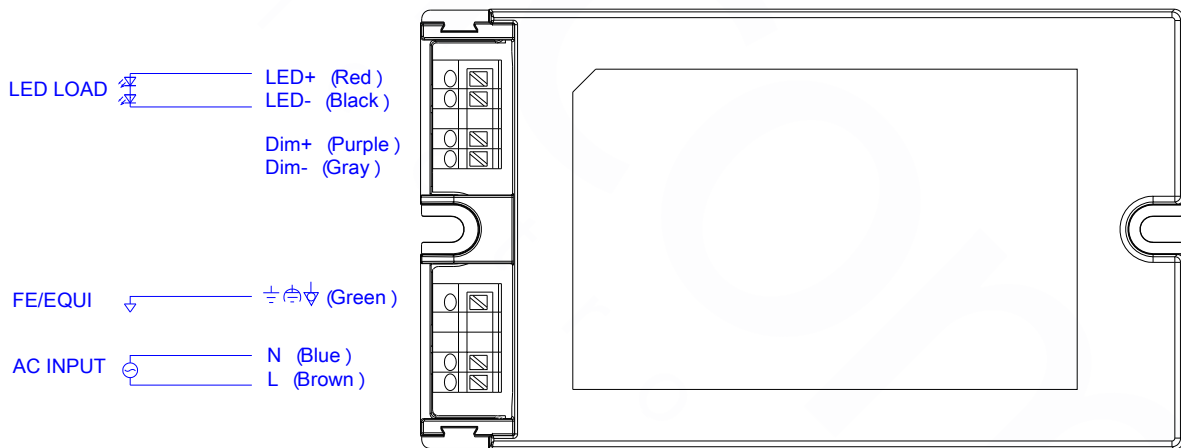

Programming Connection Diagram

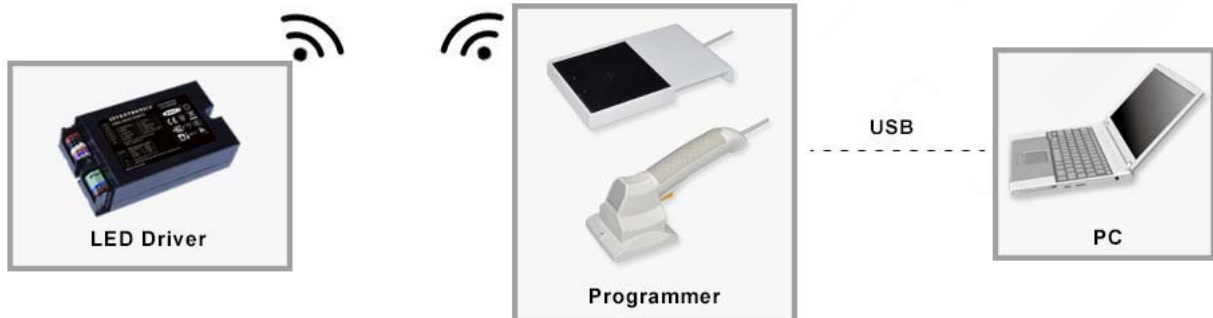

Note: The driver does not need to be powered on during the programming process.

- Please refer to [PRG-NFC-H](#) or [PRG-NFC-D](#) (Programmer) datasheet for details.

Mechanical Outline

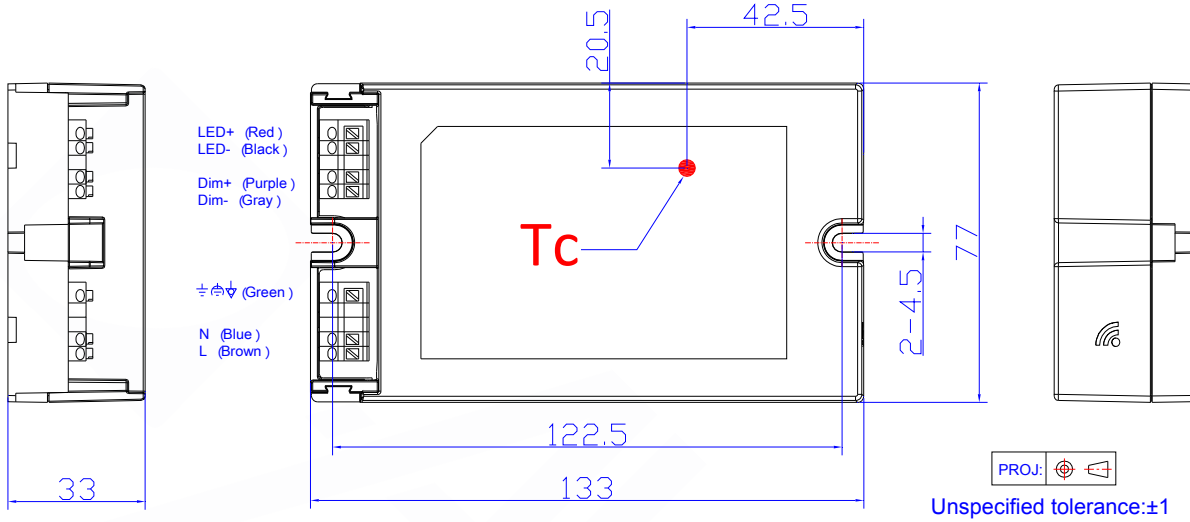

Optional Cable Clamp END-CAP02

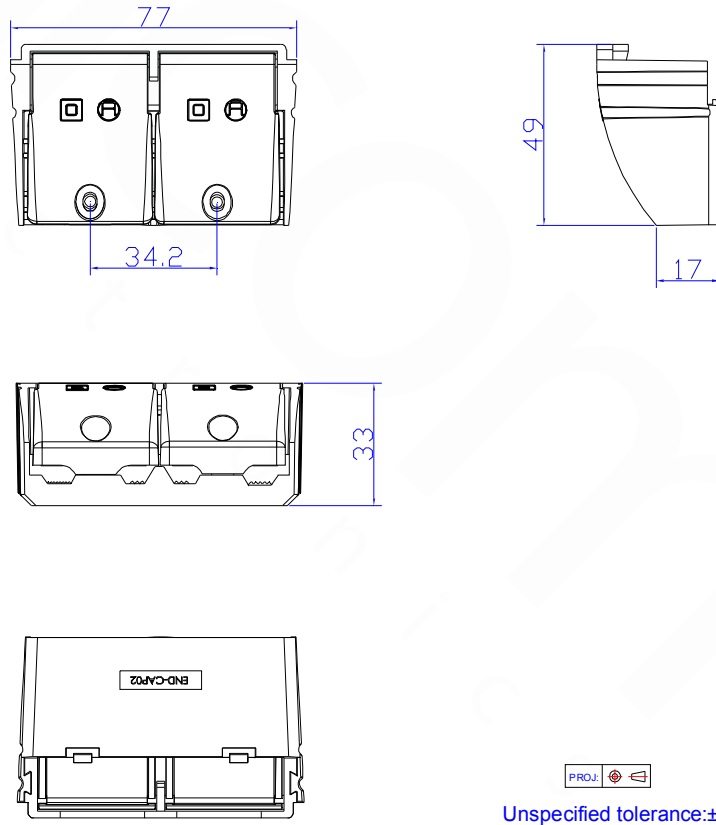

Note: The cable clamp is to be installed with EBS-040SxxxDT2 drivers for independent application. Please refer to [END-CAP02](#) datasheet for details.

RoHS Compliance

Our products comply with reference to RoHS Directive (EU) 2015/863 amending 2011/65/EU, calling for the elimination of lead and other hazardous substances from electronic products.

Revision History

Change Date	Rev.	Description of Change		
		Item	From	To
2021-04-08	A	Datasheets Release	/	/
2021-04-22	B	Models	Notes: (2)	Updated
		Input Over Voltage Withstand	/	Updated