



Sub-1GHz OOK RF Transmitter A/D Flash MCU

BC66F2123



Singel 3 | B-2550 Kontich | Belgium | Tel. +32 (0)3 458 30 33

info@alcom.be | www.alcom.be

Rivium 1e straat 52 | 2909 LE Capelle aan den IJssel | The Netherlands

Tel. +31 (0)10 288 25 00 | info@alcom.nl | www.alcom.nl

Revision: V1.00 Date: July 23, 2021

www.holtek.com

Table of Contents

Features	6
CPU Features	6
Peripheral Features.....	6
RF Transmitter Features	7
General Description	7
Block Diagram	8
Pin Assignment	8
Pin Description	9
Internally Connected Signal	10
Absolute Maximum Ratings	11
D.C. Characteristics	11
A.C. Characteristics	12
A/D Converter Electrical Characteristics	12
OPA Electrical Characteristics	13
LVR Electrical Characteristics	13
RF Characteristics	14
I ² C Characteristics.....	15
Power on Reset Electrical Characteristics	16
System Architecture	16
Clocking and Pipelining.....	16
Program Counter.....	17
Stack	18
Arithmetic and Logic Unit – ALU	18
Flash Program Memory	19
Structure.....	19
Special Vectors	19
Look-up Table.....	19
Table Program Example.....	20
In Circuit Programming – ICP	21
On-Chip Debug Support – OCDS	21
RAM Data Memory	22
Structure.....	22
General Purpose Data Memory	22
Special Purpose Data Memory	23
Special Function Register Description	24
Indirect Addressing Registers – IAR0, IAR1	24
Memory Pointers – MP0, MP1	24
Bank Pointer – BP.....	25
Accumulator – ACC.....	25

Program Counter Low Byte Register – PCL.....	25
Look-up Table Registers – TBLP, TBLH.....	25
Status Register – STATUS.....	26
EEPROM Data Memory.....	27
EEPROM Data Memory Structure	27
EEPROM Registers	27
Reading Data from the EEPROM	29
Writing Data to the EEPROM.....	29
Write Protection.....	29
EEPROM Interrupt.....	29
Programming Considerations.....	30
Oscillators	31
Oscillator Overview	31
System Clock Configurations	31
Internal High Speed RC Oscillator – HIRC	32
Internal 32kHz Oscillator – LIRC.....	32
Supplementary Oscillator.....	32
Operating Modes and System Clocks	32
System Clocks	32
System Operation Modes.....	33
Control Register	34
Operating Mode Switching.....	36
NORMAL Mode to SLOW Mode Switching.....	36
SLOW Mode to NORMAL Mode Switching.....	37
Entering the SLEEP0 Mode	38
Entering the SLEEP1 Mode	38
Entering the IDLE0 Mode.....	38
Entering the IDLE1 Mode.....	38
Standby Current Considerations	39
Wake-up.....	39
Watchdog Timer.....	40
Watchdog Timer Clock Source.....	40
Watchdog Timer Control Register	40
Watchdog Timer Operation	41
Reset and Initialisation.....	42
Reset Functions	42
Reset Initial Conditions	45
Input/Output Ports	47
Pull-high Resistors	48
Port A Wake-up	48
I/O Port Control Registers	48
Pin-shared Functions	49
I/O Pin Structures.....	51
Programming Considerations.....	51

Timer Modules – TM	52
Introduction	52
TM Operation	52
TM Clock Source.....	52
TM Interrupts.....	52
TM External Pins.....	53
TM Input/Output Pin Control Register	53
Programming Considerations.....	54
Standard Type TM – STM	55
Standard TM Operation.....	55
Standard Type TM Register Description	56
Standard Type TM Operating Modes	60
Periodic Type TM – PTM.....	70
Periodic TM Operation	70
Periodic Type TM Register Description.....	70
Periodic Type TM Operating Modes.....	75
Analog to Digital Converter	84
A/D Overview	84
A/D Converter Register Description	85
A/D Converter Operation.....	88
A/D Converter Reference Voltage.....	88
A/D Converter Input Signals.....	89
Conversion Rate and Timing Diagram	89
Summary of A/D Conversion Steps.....	90
Programming Considerations.....	90
A/D Conversion Function	90
A/D Programming Examples.....	91
RF Transmitter	92
State Control	93
RF Transmitter Registers	95
Interrupts	99
Interrupt Registers.....	99
Interrupt Operation	102
External Interrupts.....	103
Multi-function Interrupts.....	104
A/D Converter Interrupt.....	104
Time Base Interrupts	104
EEPROM Interrupt.....	105
TM Interrupts.....	105
Interrupt Wake-up Function.....	106
Programming Considerations.....	106
Application Circuits.....	107

Instruction Set.....	108
Introduction	108
Instruction Timing	108
Moving and Transferring Data.....	108
Arithmetic Operations.....	108
Logical and Rotate Operation	109
Branches and Control Transfer	109
Bit Operations	109
Table Read Operations	109
Other Operations.....	109
Instruction Set Summary	110
Table Conventions.....	110
Instruction Definition.....	112
Package Information	121
16-pin NSOP-EP (150mil) Outline Dimensions.....	122

Features

CPU Features

- Operating voltage
 - ◆ $f_{SYS}=8\text{MHz}$: 2.2V~3.6V
- Up to 0.5 μs instruction cycle with 8MHz system clock at $V_{DD}=3\text{V}$
- Power down and wake-up functions to reduce power consumption
- Oscillator type
 - ◆ Internal High Speed 8MHz RC – HIRC
 - ◆ Internal Low Speed 32kHz RC – LIRC
- Fully intergrated internal oscillator requires no external components
- Multi-mode operation: NORMAL, SLOW, IDLE and SLEEP
- All instructions executed in one or two instruction cycles
- Table read instructions
- 61 powerful instructions
- 2-level subroutine nesting
- Bit manipulation instruction

Peripheral Features

- Flash Program Memory: 1K \times 14
- RAM Data Memory: 64 \times 8
- True EEPROM Memory: 32 \times 8
- Watchdog Timer function
- 9 bidirectional I/O lines
- One pin-shared external interrupts
- Multiple Timer Modules for time measure, compare match output, capture input, PWM output, single pulse output functions
- Dual Time Base functions for generation of fixed time interrupt signals
- Three-channel 12-bit resolution A/D converter with internal reference voltage V_R
- Low voltage reset function
- Flash program memory can be re-programmed up to 10,000 times
- Flash program memory data retention > 10 years
- True EEPROM data memory can be re-programmed up to 100,000 times
- True EEPROM data memory data retention > 10 years
- Package type: 16-pin NSOP-EP

RF Transmitter Features

- Frequency bands: 315MHz, 433MHz, 868MHz, 915MHz
- Supports OOK/FSK modulation
- Supports 2-wire I²C interface
- Operating voltage range of 2.2V~3.6V
- Programmable OOK symbol rate up to 25ksps
- Programmable FSK data rate up to 50kbps
- 0.3 μ A deep sleep mode current with data retention
- TX current consumption @ 433MHz
 - ◆ 17mA @ 10dBm POUT (FSK)
 - ◆ 11mA @ 10dBm POUT (OOK, 50% duty cycle)
- On-chip VCO and Fractional-N synthesizer with integrated loop filter
- Supports low cost 16MHz crystal

General Description

The device is a Flash Memory type 8-bit high performance RISC architecture microcontroller combined with an RF transmitter designed for a range of RF control applications.

For memory features, the Flash Memory offers users the convenience of multi-programming features. Other memory includes an area of RAM Data Memory as well as an area of true EEPROM memory for storage of non-volatile data such as serial numbers, calibration data etc.

Analog features include a multi-channel 12-bit A/D converter function. Multiple and extremely flexible Timer Modules provide timing, pulse generation, capture input, compare match output, single pulse output and PWM generation functions. Protective features such as an internal Watchdog Timer and Low Voltage Reset coupled with excellent noise immunity and ESD protection ensure that reliable operation is maintained in hostile electrical environments.

A full choice of HIRC and LIRC oscillator functions are provided including a fully integrated system oscillator which requires no external components for its implementation.

The RF module is a low cost sub-GHz OOK/FSK transmitter for wireless applications in the 315MHz, 433MHz, 470MHz, 868MHz and 915MHz frequency bands. It is a highly integrated and low cost solution for one-way transmitters. It only needs a crystal, a few external capacitors and a few PA output matching components on PCB to form a complete RF solution.

The RF module consists of a highly integrated fractional-N Synthesizer and a Class-E Power Amplifier (PA). As it adopts a fractional-N synthesizer, the users can potentially design their transmitters to operate at a wider frequency range. A class-E PA can deliver up to +13dBm output power.

The inclusion of flexible I/O programming features, Time Base functions along with many other features ensure that the device will find excellent use in many wireless control products, such as wireless ceiling fans, wireless doorbells, RF switches, smart home applications, cold chain temperature detection, cold chain management (logistics) and so on.

Block Diagram

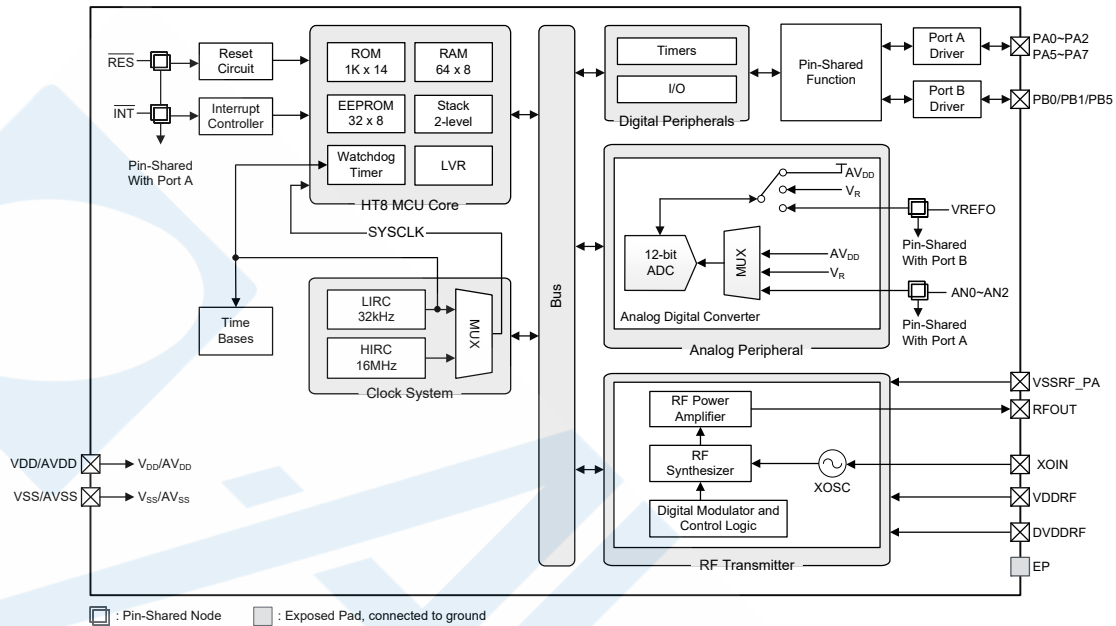

Pin Assignment

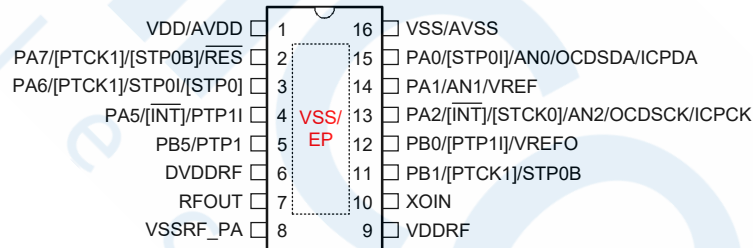

BC66F2123/BC66V2123
16 NSOP-EP-A

- Note: 1. The desired pin-shared functions are determined by the corresponding pin-shared control bits.
 2. The OCSDA and OCDSCK pins are supplied for the OCDS dedicated pins and as such only available for the BC66V2123 device which is the OCDS EV chip for the BC66F2123 device.
 3. For the unbounded pins, the pin status should be properly configured to avoid the current consumption resulting from an input floating condition. Refer to the “Standby Current Considerations” and “Input/Output Ports” sections.
 4. Bracketed pin names indicate non-default pinout remapping locations.

Pin Description

With the exception of the power pins and some relevant transformer control pins, all pins on this device can be referenced by their Port name, e.g. PA0, PA1 etc, which refer to the digital I/O function of the pins. However these Port pins are also shared with other function such as the Analog to Digital Converter, Timer Module pins etc. The function of each pin is listed in the following table, however the details behind how each pin is configured is contained in other sections of the datasheet.

Pin Name	Function	OPT	I/T	O/T	Description
PA0/[STP0I]/AN0/ OCDSDA/ICPDA	PA0	PAWU PAPU PASR	ST	CMOS	General purpose I/O. Register enabled pull-up and wake-up
	STP0I	PASR IFS0	—	CMOS	STM output
	AN0	PASR	AN	—	ADC input channel 0
	OCDSDA	—	ST	CMOS	On Chip Debug System Data Line (OCDS EV only)
	ICPDA	—	ST	CMOS	ICP Data Line
PA1/AN1/VREF	PA1	PAWU PAPU PASR	ST	CMOS	General purpose I/O. Register enabled pull-up and wake-up
	AN1	PASR	AN	—	ADC input channel 1
	VREF	PASR	AN	—	ADC external reference voltage input
PA2/[INT]/[STCK0]/ AN2/OCDSCK/ICPCK	PA2	PAWU PAPU PASR	ST	CMOS	General purpose I/O. Register enabled pull-up and wake-up
	$\overline{\text{INT}}$	PASR IFS0	ST	—	External interrupt input
	STCK0	IFS0	ST	—	STM clock input
	AN2	PASR	AN	—	ADC input channel 2
	OCDSCK	—	ST	—	On Chip Debug System Clock Line (OCDS EV only)
	ICPCK	—	ST	CMOS	ICP Clock Line
PA5/[INT]/PTP1I	PA5	PAWU PAPU	ST	CMOS	General purpose I/O. Register enabled pull-up and wake-up
	$\overline{\text{INT}}$	PASR IFS0	ST	—	External interrupt input
	PTP1I	IFS0	ST	—	PTM capture input
PA6/[PTCK1]/STP0I/ [STP0]	PA6	PAWU PAPU PASR	ST	CMOS	General purpose I/O. Register enabled pull-up and wake-up
	PTCK1	PASR IFS0	ST	—	PTM clock input
	STP0I	PASR IFS0	ST	—	STM capture input
	STP0	PASR	—	CMOS	STM output
PA7/[PTCK1]/[STP0B]/ RES	PA7	PAWU PAPU PASR	ST	CMOS	General purpose I/O. Register enabled pull-up and wake-up
	PTCK1	PASR IFS0	ST	—	PTM clock input
	STP0B	PASR	ST	CMOS	STM inverting output
	RES	RSTC	ST	—	External reset input

Pin Name	Function	OPT	I/T	O/T	Description
PB0/[PTP1I]/VREFO	PB0	PBPU PBSR	ST	CMOS	General purpose I/O. Register enabled pull-up
	PTP1I	PBSR IFS0	ST	—	PTM capture input
	VREFO	PBSR	—	AN	ADC reference voltage output
PB1/[PTCK1]/STP0B	PB1	PBPU PBSR	ST	CMOS	General purpose I/O. Register enabled pull-up
	PTCK1	PBSR IFS0	ST	—	PTM clock input
	STP0B	PBSR	ST	CMOS	STM inverting output
PB5/PTP1	PB5	PBPU PBSR	ST	CMOS	General purpose I/O. Register enabled pull-up
	PTP1	PBSR	—	CMOS	PTM output
VDD	VDD	—	PWR	—	Digital positive power supply
AVDD	AVDD	—	PWR	—	Analog positive power supply
VSS	VSS	—	PWR	—	Digital negative power supply
AVSS	AVSS	—	PWR	—	Analog negative power supply
VDDRF	VDDRF	—	PWR	—	RF analog positive power supply
DVDDRF	DVDDRF	—	PWR	—	RF digital positive power supply
RFOUT	RFOUT	—	—	AN	RF power amplifier output, connected to a matching circuit
VSSRF_PA	VSSRF_PA	—	PWR	—	RF power amplifier negative power supply
XOIN	XOIN	—	AN	—	RF External Crystal input
VSS/EP	VSS	—	PWR	—	Exposed pad, must be connected to ground

Legend: I/T: Input type;

PWR: Power;

ST: Schmitt Trigger input;

AN: Analog signal.

O/T: Output type;

OPT: Optional by register option;

CMOS: CMOS output;

Internally Connected Signal

There is an interconnection between the MCU, PB2 and PB3 line, and the RF PCLK and DIN line, both of which are not bonded to the external package. Users should properly configure the PB2 and PB3 relevant I/O control to implement correct interconnection.

MCU Signal Name	Type	RF Signal Name	Function	Type	Description
PB2	DO	PCLK/SCL	PCLK	DI	RF clock input
			SCL	DI	RF I ² C clock input line in configuration mode
PB3	DO/DI	DIN/SDA	DIN	DI	RF transmitter data input
			SDA	DI/DO	RF I ² C data input line in configuration mode

Legend: DO: Digital output; DI: Digital Input.

Absolute Maximum Ratings

Supply Voltage	$V_{SS}-0.3V$ to $V_{SS}+3.6V$
Input Voltage	$V_{SS}-0.3V$ to $V_{DD}+0.3V$
Storage Temperature.....	$-55^{\circ}C$ to $150^{\circ}C$
Operating Temperature.....	$-40^{\circ}C$ to $85^{\circ}C$
I_{OL} Total	80mA
I_{OH} Total.....	-80mA
Total Power Dissipation	500mW
ESD HBM	$\pm 2KV$

The device is ESD sensitive. HBM (Human Body Mode) is based on MIL-STD-883.

Note: These are stress ratings only. Stresses exceeding the range specified under "Absolute Maximum Ratings" may cause substantial damage to this device. Functional operation of this device at other conditions beyond those listed in the specification is not implied and prolonged exposure to extreme conditions may affect device reliability.

D.C. Characteristics

$T_a=25^{\circ}C$

Symbol	Parameter	Test Conditions		Min.	Typ.	Max.	Unit
		V_{DD}	Conditions				
V_{DD}	Operating Voltage (HIRC)	—	$f_{SYS}=8MHz$	2.2	—	3.6	V
I_{DD1}	Operating Current, Normal Mode, $f_{SYS}=f_H$ (HIRC)	3V	No load, $f_H=8MHz$, ADC off, WDT enable, LVR enable	—	1.0	2.0	mA
I_{DD2}	Operating Current, Slow Mode, $f_{SYS}=f_L=LIRC$	3V	No load, $f_{SYS}=LIRC$, ADC off, WDT enable, LVR enable	—	20	30	μA
I_{DD3}	Operating Current, Normal Mode, $f_H=8MHz$ (HIRC)	3V	No load, $f_{SYS}=f_H/2$, ADC off, WDT enable, LVR enable	—	1.0	1.5	mA
		3V	No load, $f_{SYS}=f_H/4$, ADC off, WDT enable, LVR enable	—	0.9	1.3	mA
		3V	No load, $f_{SYS}=f_H/8$, ADC off, WDT enable, LVR enable	—	0.8	1.1	mA
		3V	No load, $f_{SYS}=f_H/16$, ADC off, WDT enable, LVR enable	—	0.7	1.0	mA
		3V	No load, $f_{SYS}=f_H/32$, ADC off, WDT enable, LVR enable	—	0.6	0.9	mA
		3V	No load, $f_{SYS}=f_H/64$, ADC off, WDT enable, LVR enable	—	0.5	0.8	mA
I_{IDLE0}	IDLE0 Mode Standby Current (LIRC on)	3V	No load, ADC off, WDT enable, LVR disable	—	1.3	3.0	μA
I_{IDLE1}	IDLE1 Mode Standby Current (HIRC)	3V	No load, ADC off, WDT enable, $f_{SYS}=8MHz$ on	—	0.8	1.6	mA
I_{SLEEP0}	SLEEP0 Mode Standby Current (LIRC off)	3V	No load, ADC off, WDT disable, LVR disable	—	0.1	1.0	μA
I_{SLEEP1}	SLEEP1 Mode Standby Current (LIRC on)	3V	No load, ADC off, WDT enable, LVR disable	—	1.3	5.0	μA
V_{IL1}	Input Low Voltage for I/O Ports except RES pin	—	—	0	—	$0.2V_{DD}$	V
V_{IH1}	Input High Voltage for I/O Ports except RES pin	—	—	$0.8V_{DD}$	—	V_{DD}	V
V_{IL2}	Input Low Voltage (RES)	—	—	0	—	$0.4V_{DD}$	V
V_{IH2}	Input High Voltage (RES)	—	—	$0.9V_{DD}$	—	V_{DD}	V

Symbol	Parameter	Test Conditions		Min.	Typ.	Max.	Unit
		V _{DD}	Conditions				
I _{OL}	I/O Port Sink Current	3V	V _{OL} =0.1V _{DD}	18	36	—	mA
		5V	V _{OL} =0.1V _{DD}	40	80	—	mA
I _{OH}	I/O Port Source Current	3V	V _{OH} =0.9V _{DD}	-3	-6	—	mA
		5V	V _{OH} =0.9V _{DD}	-7	-14	—	mA
R _{PH}	Pull-high Resistance for I/O Ports	3V	—	20	60	100	kΩ
		5V	—	10	30	50	kΩ
I _{OCDS}	Operating Current, Normal Mode, f _{sys} =f _H (HIRC) (for OCDS EV testing, connect to an e-Link)	3V	No load, f _H =8MHz, ADC off, WDT enable	—	1.4	2.0	mA

A.C. Characteristics

Ta=25°C

Symbol	Parameter	Test Conditions		Min.	Typ.	Max.	Unit
		V _{DD}	Condition				
f _{CPU}	Operating Clock	2.2V~3.6V	—	DC	—	8	MHz
f _{HIRC}	System Clock (HIRC)	3V	Ta=25°C	-2%	8	+2%	MHz
		3V	Ta=0°C to 70°C	-5%	8	+5%	MHz
		2.2V~3.6V	Ta=0°C to 70°C	-8%	8	+8%	MHz
		2.2V~3.6V	Ta=-40°C to 85°C	-12%	8	+12%	MHz
f _{LIRC}	System Clock (LIRC)	2.2V~3.6V	Ta=-40°C to 85°C	8	32	50	kHz
t _{TIMER}	xTCKn, xTPnI Input Pulse Width	—	—	0.3	—	—	μs
t _{RES}	External Reset Low Pulse Width	—	—	10	—	—	μs
t _{INT}	External Interrupt Pulse Width	—	—	0.3	—	—	μs
t _{EEERD}	EEPROM Read Time	—	—	—	2	4	t _{sys}
t _{EEWR}	EEPROM Write Time	—	—	—	2	5	ms
t _{SST}	System Start-up Timer Period (Wake-up from HALT, f _{sys} Off at HALT State)	—	f _{sys} =HIRC	16	—	—	t _{sys}
		—	f _{sys} =LIRC	2	—	—	
t _{RSTD}	System Reset Delay Time (Power-on Reset, LVR Reset, WDT S/W Reset (WDTC))	—	—	25	50	100	ms
	System Reset Delay Time (RES Reset, WDT Normal Reset)	—	—	8.3	16.7	33.3	ms

Note: 1. t_{sys}=1/f_{sys}

2. To maintain the accuracy of the internal HIRC oscillator frequency, a 0.1μF decoupling capacitor should be connected between V_{DD} and V_{SS} and located as close to the device as possible.

A/D Converter Electrical Characteristics

Ta=25°C

Symbol	Parameter	Test Conditions		Min.	Typ.	Max.	Unit
		V _{DD}	Conditions				
A _{VDD}	A/D Converter Operating Voltage	—	—	2.2	—	3.6	V
V _{ADI}	A/D Converter Input Voltage	—	—	0	—	A _{VDD} / V _{REF}	V
V _{REF}	A/D Converter Reference Voltage	—	—	2	—	A _{VDD}	V
DNL	Differential Non-linearity	2.2V~2.7V	V _{REF} =A _{VDD} =V _{DD} , t _{ADCK} =8μs	-15	—	+15	LSB
		2.7V~3.6V	V _{REF} =A _{VDD} =V _{DD} , t _{ADCK} =0.5μs	-3	—	+3	LSB

Symbol	Parameter	Test Conditions		Min.	Typ.	Max.	Unit
		V _{DD}	Conditions				
INL	Integral Non-linearity	2.2V~2.7V	V _{REF} =AV _{DD} =V _{DD} , t _{ADCK} =8μs	-16	—	+16	LSB
		2.7V~3.6V	V _{REF} =AV _{DD} =V _{DD} , t _{ADCK} =0.5μs	-4	—	+4	LSB
I _{ADC}	Additional Current for A/D Converter Enable	3V	No load (t _{ADCK} =0.5μs)	—	1.0	2.0	mA
t _{ADCK}	A/D Converter Clock Period	2.2V~2.7V	—	8	—	10	μs
		2.7V~3.6V	—	0.5	—	10	μs
t _{ADC}	A/D Conversion Time (Include Sample and Hold Time)	—	12-bit A/D converter	16	—	20	t _{ADCK}
t _{ADS}	A/D Converter Sampling Time	—	—	—	4	—	t _{ADCK}
t _{ON2ST}	A/D Converter On-to-Start Time	—	—	4	—	—	μs

OPA Electrical Characteristics

Ta=25°C

Symbol	Parameter	Test Conditions		Min.	Typ.	Max.	Unit
		V _{DD}	Conditions				
AV _{DD}	OPA Operating Voltage	—	—	2.7	—	3.6	V
I _{OPA}	OPA Operating Current	3V	No load	—	200	350	μA
V _{OPOS1}	Input Offset Voltage	3V	—	-15	—	15	mV
V _{CM}	Common Mode Voltage Range	3V	—	0.2	—	V _{DD} -1.4	V
PSRR	Power Supply Rejection Ratio	3V	—	60	80	—	dB
CMRR	Common mode Rejection Ratio	3V	—	60	80	—	dB
SR	Slew rate +, Slew rate -	3V	—	0.8	1.5	—	V/μs
GBW	Gain Band Width	3V	—	500	—	—	kHz
ERRG	OPA Gain Error	3V	Gain=1/2/3/4 If OPA input voltage ≥ 0.2V	-5	Gain	+5	%
t _{START}	OPA Turn On Stable Time	—	No external load	—	—	22	μs

LVR Electrical Characteristics

Ta=25°C

Symbol	Parameter	Test Conditions		Min.	Typ.	Max.	Unit
		V _{DD}	Conditions				
V _{LVR}	Low Voltage Reset Voltage	—	LVR Enable, 1.9V option	-5%	1.9	+5%	V
V _{BG}	Bandgap Reference Voltage	—	T _J =+25°C @ 3.15V	-5%	1.04	+5%	V
t _{BGS}	V _{BG} Turn On Stable Time	—	No load	—	—	200	μs
t _{LVR}	Minimum Low Voltage Width to Reset	—	—	160	320	640	μs

RF Characteristics

Ta=25°C, V_{DD}=3.3V, f_{XTAL}=16MHz, OOK/FSK modulation with Matching circuit,
PAOUT is powered by V_{DD}=3.3V, unless otherwise noted

Symbol	Parameter	Test Conditions	Min.	Typ.	Max.	Unit
T _{OP}	Operating Temperature	—	-40	—	85	°C
V _{DD}	Supply Voltage	—	2.2	3.3	3.6	V
Digital I/Os						
V _{IH}	High Level Input Voltage	—	0.7V _{DD}	—	V _{DD}	V
V _{IL}	Low Level Input Voltage	—	0	—	0.3V _{DD}	V
V _{OH}	High Level Output Voltage	I _{OH} =-5mA	0.8V _{DD}	—	V _{DD}	V
V _{OL}	Low Level Output Voltage	I _{OL} =5mA	0	—	0.2V _{DD}	V
Current Consumption						
I _{Sleep}	Deep Sleep Mode Current Consumption	—	—	0.4	1.0	µA
I _{Standby}	Idle Mode Current Consumption	XTAL on, PA off, Synthesizer on	—	6.5	—	mA
I _{TX}	High Data Current Consumption @ 315MHz (Data=1)	P _{RF} =0dBm	—	11	—	mA
		P _{RF} =10dBm	—	19	—	
		P _{RF} =13dBm	—	24	—	
	High Data Current Consumption @ 433MHz (Data=1)	P _{RF} =0dBm	—	11	—	mA
		P _{RF} =10dBm	—	17	—	
		P _{RF} =13dBm	—	24	—	
	High Data Current Consumption @ 868MHz (Data=1)	P _{RF} =0dBm	—	11	—	mA
		P _{RF} =10dBm	—	19	—	
		P _{RF} =13dBm	—	24	—	
	High Data Current Consumption @ 915MHz (Data=1)	P _{RF} =0dBm	—	12	—	mA
		P _{RF} =10dBm	—	20	—	
		P _{RF} =13dBm	—	25	—	
Transmitter Characteristics						
f _{RF}	RF Frequency Band	315MHz band	—	315	—	MHz
		433MHz band	—	433.92	—	
		868MHz band	—	868.35	—	
		915MHz band	—	915	—	
SR	Symbol Rate	OOK modulation	0.5	—	25	ksps
DR	Data Rate	FSK modulation (@f _{DEV} =12.5kHz)	0.5	—	50	kbps
P _{RF}	RF Transmit Output Power	433MHz band	0	—	13	dBm
		868MHz band	0	—	13	
t _{ST}	RF Transmit Settling Time	Standby mode to Transmit mode	—	370	—	µs
ER _{OOK}	OOK Extinction Ratio	OOK modulation depth	—	70	—	dB
f _{DEV}	Frequency Deviation	FSK modulation @ f _{XTAL} =16MHz	2	—	100	kHz
	Output Blanking	From Deep Sleep to Transmit mode	—	—	1	Ms
	One Shot Delay Time	OOK/FSK	4	—	32	ms
S.E. _{TX}	TX Spurious Emission (P _{RF} =10dBm)	f < 1GHz	—	—	-36	dBm
		47MHz < f < 74MHz	—	—	-54	
		87.5MHz < f < 118MHz				
		174MHz < f < 230MHz				
		470MHz < f < 862MHz	—	—	-30	
2 nd , 3 rd Harmonic	—	—	-30			

Symbol	Parameter	Test Conditions	Min.	Typ.	Max.	Unit
LO Characteristics						
f _{LO}	RF Frequency Coverage Range	315MHz band	290	—	335	MHz
		433MHz band	415	—	490	
		868MHz band	830	—	960	
f _{STEP}	LO Frequency Resolution	—	—	—	1	kHz
PN _{LO}	433MHz Phase Noise	@ 100kHz offset	—	-76	—	dBc/ Hz
		@ 1MHz offset	—	-104	—	
	868MHz Phase Noise	@ 100kHz offset	—	-70	—	
		@ 1MHz offset	—	-100	—	
Crystal Oscillator						
f _{XTAL}	XTAL Frequency	—	—	16	—	MHz
ESR	XTAL Equivalent Series Resistance	—	—	—	100	Ω
C _{LOAD}	XTAL Capacitor Load	—	12	16	20	pF
TOL ^(Note)	XTAL Tolerance	—	-20	—	+20	ppm
t _{SU}	XTAL Startup Time	49US XO	—	—	1	ms

Note: 1. This is the total tolerance including (1) Initial tolerance (2) Crystal loading (3) Aging and (4) Temperature dependence.

2. The acceptable crystal tolerance depends on RF frequency and channel spacing/band width.

I²C Characteristics

T_a=-40°C~85°C, unless otherwise noted

Symbol	Parameter	Test Conditions	Min.	Typ.	Max.	Unit
I²C Characteristics						
f _{SCL}	Serial Clock Frequency	—	—	—	1	MHz
t _{BUF}	Bus Free Time between Stop and Start Condition	SCL=1MHz	250	—	—	ns
t _{LOW}	SCL Low Time	SCL=1MHz	500	—	—	ns
t _{HIGH}	SCL High Time	SCL=1MHz	500	—	—	ns
t _{SU(DAT)}	Data Setup Time	SCL=1MHz	100	—	—	ns
t _{SU(STA)}	Start Condition Setup Time	SCL=1MHz	250	—	—	ns
t _{SU(STO)}	Stop Condition Setup Time	SCL=1MHz	250	—	—	ns
t _{H(DAT)}	Data Hold Time	SCL=1MHz	100	—	—	ns
t _{H(STA)}	Start Condition Hold Time	SCL=1MHz	250	—	—	ns
t _{r(SCL)}	Rise Time of SCL Signal	SCL=1MHz	—	—	100	ns
t _{f(SCL)}	Fall Time of SCL Signal	SCL=1MHz	—	—	100	ns
t _{r(SDA)}	Rise Time of SDA Signal	SCL=1MHz	—	—	100	ns
t _{f(SDA)}	Fall Time of SDA Signal	SCL=1MHz	—	—	100	ns

Power on Reset Electrical Characteristics

Ta=25°C

Symbol	Parameter	Test Conditions		Min.	Typ.	Max.	Unit
		V _{DD}	Conditions				
V _{POR}	V _{DD} Start Voltage to Ensure Power-on Reset	—	—	—	—	100	mV
RR _{POR}	V _{DD} Rising Rate to Ensure Power-on Reset	—	—	0.035	—	—	V/ms
t _{POR}	Minimum Time for V _{DD} Stays at V _{POR} to Ensure Power-on Reset	—	—	1	—	—	ms

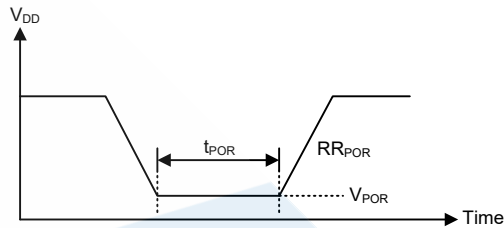

System Architecture

A key factor in the high-performance features of the Holtek range of microcontrollers is attributed to their internal system architecture. The device takes advantage of the usual features found within RISC microcontrollers providing increased speed of operation and Periodic performance. The pipelining scheme is implemented in such a way that instruction fetching and instruction execution are overlapped, hence instructions are effectively executed in one cycle, with the exception of branch or call instructions. An 8-bit wide ALU is used in practically all instruction set operations, which carries out arithmetic operations, logic operations, rotation, increment, decrement, branch decisions, etc. The internal data path is simplified by moving data through the Accumulator and the ALU. Certain internal registers are implemented in the Data Memory and can be directly or indirectly addressed. The simple addressing methods of these registers along with additional architectural features ensure that a minimum of external components is required to provide a functional I/O and A/D control system with maximum reliability and flexibility. This makes this device suitable for low-cost, high-volume production for controller applications

Clocking and Pipelining

The main system clock, derived from either a HIRC or LIRC oscillator is subdivided into four internally generated non-overlapping clocks, T1~T4. The Program Counter is incremented at the beginning of the T1 clock during which time a new instruction is fetched. The remaining T2~T4 clocks carry out the decoding and execution functions. In this way, one T1~T4 clock cycle forms one instruction cycle. Although the fetching and execution of instructions takes place in consecutive instruction cycles, the pipelining structure of the microcontroller ensures that instructions are effectively executed in one instruction cycle. The exception to this are instructions where the contents of the Program Counter are changed, such as subroutine calls or jumps, in which case the instruction will take one more instruction cycle to execute.

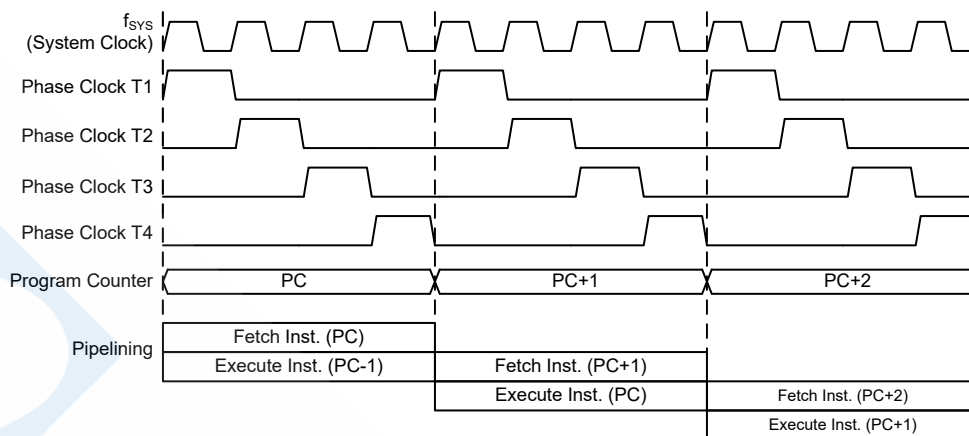

System Clocking and Pipelining

For instructions involving branches, such as jump or call instructions, two machine cycles are required to complete instruction execution. An extra cycle is required as the program takes one cycle to first obtain the actual jump or call address and then another cycle to actually execute the branch. The requirement for this extra cycle should be taken into account by programmers in timing sensitive applications.

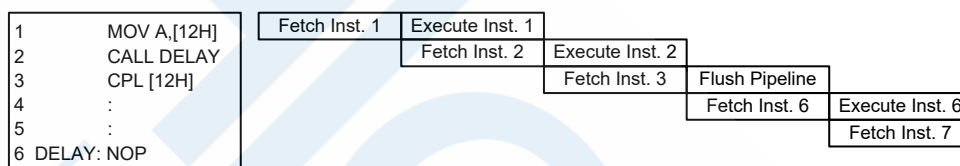

Instruction Fetching

Program Counter

During program execution, the Program Counter is used to keep track of the address of the next instruction to be executed. It is automatically incremented by one each time an instruction is executed except for instructions, such as “JMP” or “CALL” that demand a jump to a non-consecutive Program Memory address. Only the lower 8 bits, known as the Program Counter Low Register, are directly addressable by the application program.

When executing instructions requiring jumps to non-consecutive addresses such as a jump instruction, a subroutine call, interrupt or reset, etc., the microcontroller manages program control by loading the required address into the Program Counter. For conditional skip instructions, once the condition has been met, the next instruction, which has already been fetched during the present instruction execution, is discarded and a dummy cycle takes its place while the correct instruction is obtained.

Program Counter	
Program Counter High Byte	PCL Register
PC9~PC8	PCL7~PCL0

The lower byte of the Program Counter, known as the Program Counter Low register or PCL, is available for program control and is a readable and writeable register. By transferring data directly into this register, a short program jump can be executed directly, however, as only this low byte is available for manipulation, the jumps are limited to the present page of memory, that is 256 locations. When such program jumps are executed it should also be noted that a dummy cycle will be inserted. Manipulating the PCL register may cause program branching, so an extra cycle is needed to pre-fetch.

Stack

This is a special part of the memory which is used to save the contents of the Program Counter only. The stack is neither part of the data nor part of the program space, and is neither readable nor writeable. The activated level is indexed by the Stack Pointer, and is neither readable nor writeable. At a subroutine call or interrupt acknowledge signal, the contents of the Program Counter are pushed onto the stack. At the end of a subroutine or an interrupt routine, signaled by a return instruction, RET or RETI, the Program Counter is restored to its previous value from the stack. After a device reset, the Stack Pointer will point to the top of the stack.

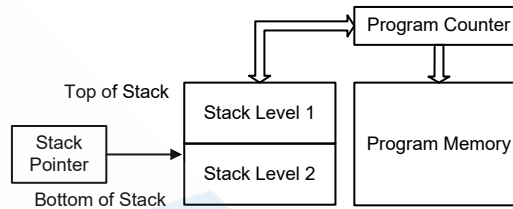

If the stack is full and an enabled interrupt takes place, the interrupt request flag will be recorded but the acknowledge signal will be inhibited. When the Stack Pointer is decremented, by RET or RETI, the interrupt will be serviced. This feature prevents stack overflow allowing the programmer to use the structure more easily. However, when the stack is full, a CALL subroutine instruction can still be executed which will result in a stack overflow. Precautions should be taken to avoid such cases which might cause unpredictable program branching. If the stack is overflow, the first Program Counter save in the stack will be lost.

Arithmetic and Logic Unit – ALU

The arithmetic-logic unit or ALU is a critical area of the microcontroller that carries out arithmetic and logic operations of the instruction set. Connected to the main microcontroller data bus, the ALU receives related instruction codes and performs the required arithmetic or logical operations after which the result will be placed in the specified register. As these ALU calculation or operations may result in carry, borrow or other status changes, the status register will be correspondingly updated to reflect these changes. The ALU supports the following functions:

- Arithmetic operations:
ADD, ADDM, ADC, ADCM, SUB, SUBM, SBC, SBCM, DAA
- Logic operations:
AND, OR, XOR, ANDM, ORM, XORM, CPL, CPLA
- Rotation:
RRA, RR, RRCA, RRC, RLA, RL, RLCA, RLC
- Increment and Decrement:
INCA, INC, DECA, DEC
- Branch decision:
JMP, SZ, SZA, SNZ, SIZ, SDZ, SIZA, SDZA, CALL, RET, RETI

Flash Program Memory

The Program Memory is the location where the user code or program is stored. For the device the Program Memory are Flash type, which means it can be programmed and re-programmed a large number of times, allowing the user the convenience of code modification on the same device. By using the appropriate programming tools, this Flash device offers users the flexibility to conveniently debug and develop their applications while also offering a means of field programming and updating.

Structure

The Program Memory has a capacity of 1K×14 bits. The Program Memory is addressed by the Program Counter and also contains data, table information and interrupt entries. Table data, which can be setup in any location within the Program Memory, is addressed by a separate table pointer register.

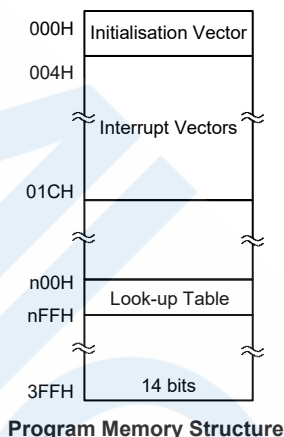

Special Vectors

Within the Program Memory, certain locations are reserved for the reset and interrupts. The location 000H is reserved for use by the device reset for program initialisation. After a device reset is initiated, the program will jump to this location and begin execution.

Look-up Table

Any location within the Program Memory can be defined as a look-up table where programmers can store fixed data. To use the look-up table, the table pointer must first be setup by placing the address of the look up data to be retrieved in the table pointer register, TBLP. This register defines the total address of the look-up table.

After setting up the table pointer, the table data can be retrieved from the Program Memory using the “TABRD[m]” or “TABRDL[m]” instructions, respectively. When the instruction is executed, the lower order table byte from the Program Memory will be transferred to the user defined Data Memory register [m] as specified in the instruction. The higher order table data byte from the Program Memory will be transferred to the TBLH special register. Any unused bits in this transferred higher order byte will be read as “0”.

The accompanying diagram illustrates the addressing data flow of the look-up table.

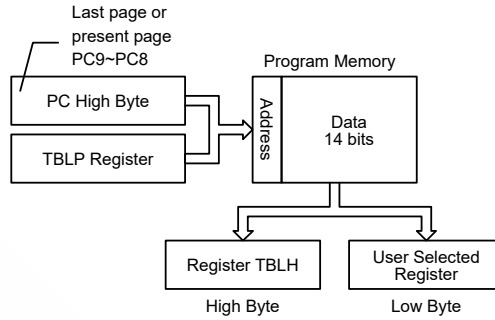

Table Program Example

The following example shows how the table pointer and table data is defined and retrieved from the microcontroller. This example uses raw table data located in the Program Memory which is stored there using the ORG statement. The value at this ORG statement is “300H” which refers to the start address of the last page within the 1K words Program Memory of the device. The table pointer is setup here to have an initial value of “06H”. This will ensure that the first data read from the data table will be at the Program Memory address “306H” or 6 locations after the start of the last page. Note that the value for the table pointer is referenced to the first address of the current page if the “TABRDL [m]” instruction is being used. The high byte of the table data which in this case is equal to zero will be transferred to the TBLH register automatically when the “TABRDL [m]” instruction is executed.

Because the TBLH register is a read/write register and can be restored, care should be taken to ensure its protection if both the main routine and Interrupt Service Routine use table read instructions. If using the table read instructions, the Interrupt Service Routines may change the value of the TBLH and subsequently cause errors if used again by the main routine. As a rule it is recommended that simultaneous use of the table read instructions should be avoided. However, in situations where simultaneous use cannot be avoided, the interrupts should be disabled prior to the execution of any main routine table-read instructions. Note that all table related instructions require two instruction cycles to complete their operation.

Table Read Program Example

```

tempreg1 db ? ; temporary register #1
tempreg2 db ? ; temporary register #2
:
:
mov a,06h ; initialise low table pointer - note that this address is referenced
mov tblp,a ; to the last page or present page
:
:
tabrdl tempreg1 ; transfers value in table referenced by table pointer data at program
; memory address "306H" transferred to tempreg1 and TBLH
dec tblp ; reduce value of table pointer by one
tabrdl tempreg2 ; transfers value in table referenced by table pointer data at program
; memory address "305H" transferred to tempreg2 and TBLH in this
; example the data "1AH" is transferred to tempreg1 and data "0FH" to
; register tempreg2
:
:
org 300h ; sets initial address of program memory
dc 00Ah, 00Bh, 00Ch, 00Dh, 00Eh, 00Fh, 01Ah, 01Bh
:
:

```

In Circuit Programming – ICP

The provision of Flash type Program Memory provides the user with a means of convenient and easy upgrades and modifications to their programs on the same device. As an additional convenience, Holtek has provided a means of programming the microcontroller in-circuit using a 4-pin interface. This provides manufacturers with the possibility of manufacturing their circuit boards complete with a programmed or un-programmed microcontroller, and then programming or upgrading the program at a later stage. This enables product manufacturers to easily keep their manufactured products supplied with the latest program releases without removal and re-insertion of the device.

Holtek Write Pins	MCU Programming Pins	Function
ICPDA	PA0	Programming Serial Data
ICPCK	PA2	Programming Serial Clock
VDD	VDD	Power Supply
VSS	VSS	Ground

The Program Memory can be programmed serially in-circuit using this 4-wire interface. Data is downloaded and uploaded serially on a single pin with an additional line for the clock. Two additional lines are required for the power supply and ground. The technical details regarding the in-circuit programming of the device are beyond the scope of this document and will be supplied in supplementary literature.

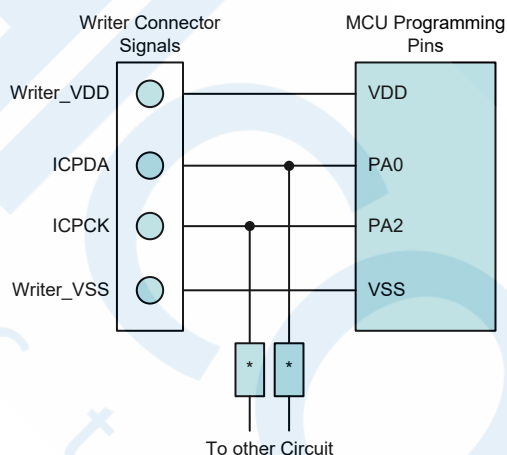

Note: * may be resistor or capacitor. The resistance of * must be greater than 1k or the capacitance of * must be less than 1nF.

On-Chip Debug Support – OCDS

There is an EV chip which is used to emulate the BC66F2123. This EV chip device also provides an “On-Chip Debug” function to debug the device during the development process. The EV chip and the actual MCU device is almost functionally compatible except for the “On-Chip Debug” function. Users can use the EV chip device to emulate the real chip device behavior by connecting the OCDSDA and OCDSCK pins to the Holtek HT-IDE development tools. The OCDSDA pin is the OCDS Data/Address input/output pin while the OCDSCK pin is the OCDS clock input pin. When users use the EV chip for debugging, other functions which are shared with the OCDSDA and OCDSCK pins in the actual MCU device will have no effect in the EV chip. However, the two OCDS pins which are pin-shared with the ICP programming pins are still used as the Flash Memory programming pins for ICP. For a more detailed OCDS description, refer to the corresponding document named “Holtek e-Link for 8-bit MCU OCDS User’s Guide”.

Holtek e-Link Pins	EV Chip Pins	Pin Description
OCSDA	OCSDA	On-chip Debug Support Data/Address input/output
OCDSCK	OCDSCK	On-chip Debug Support Clock input
VDD	VDD	Power Supply
GND	VSS	Ground

RAM Data Memory

The Data Memory is a volatile area of 8-bit wide RAM internal memory and is the location where temporary information is stored.

Structure

Divided into two sections, the first of these is an area of RAM, known as the Special Function Data Memory. Here are located registers which are necessary for correct operation of the device. Many of these registers can be read from and written to directly under program control, however, some remain protected from user manipulation. The second area of Data Memory is known as the General Purpose Data Memory, which is reserved for general purpose use. All locations within this area are read and write accessible under program control.

The overall Data Memory is subdivided into two banks. The Special Purpose Data Memory registers are accessible in all banks, with the exception of the EEC register at address 40H, which is only accessible in Bank 1. Switching between the different Data Memory banks is achieved by setting the Bank Pointer to the correct value. The start address of the Data Memory for the device is the address 00H.

Capacity	Bank 0	Bank 1
64×8	40H~7FH	40H EEC register only

General Purpose Data Memory

There is 64 bytes of general purpose data memory which are arranged in Bank 0 and Bank1. All microcontroller programs require an area of read/write memory where temporary data can be stored and retrieved for use later. It is this area of RAM memory that is known as General Purpose Data Memory. This area of Data Memory is fully accessible by the user programming for both reading and writing operations. By using the bit operation instructions individual bits can be set or reset under program control giving the user a large range of flexibility for bit manipulation in the Data Memory.

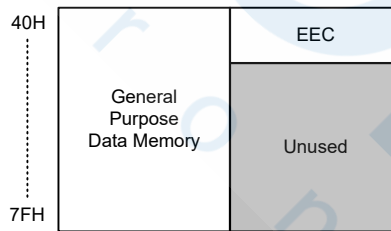

General Purpose Data Memory

Special Purpose Data Memory

This area of Data Memory is where registers, necessary for the correct operation of the microcontroller, are stored. Most of the registers are both readable and writeable but some are protected and are readable only, the details of which are located under the relevant Special Function Register section. Note that for locations that are unused, any read instruction to these addresses will return the value “00H”.

Bank 0 & Bank 1		Bank 0 & Bank 1	
00H	IAR0	20H	SADOL
01H	MP0	21H	SADOH
02H	IAR1	22H	SADC0
03H	MP1	23H	SADC1
04H	BP	24H	SADC2
05H	ACC	25H	RSTC
06H	PCL	26H	PASR
07H	TBLP	27H	PBSR
08H	TBLH	28H	STM0C0
09H	Unused	29H	STM0C1
0AH	STATUS	2AH	STM0DL
0BH	SMOD	2BH	STM0DH
0CH	Unused	2CH	STM0AL
0DH	INTEG	2DH	STM0AH
0EH	INTC0	2EH	Unused
0FH	INTC1	2FH	PB
10H	Unused	30H	PBC
11H	MFI0	31H	PBPU
12H	MFI1	32H	PTM1C0
13H	Unused	33H	PTM1C1
14H	PA	34H	PTM1DL
15H	PAC	35H	PTM1DH
16H	PAPU	36H	PTM1AL
17H	PAWU	37H	PTM1AH
18H	IFS0	38H	PTM1RPL
19H	WDTC	39H	PTM1RPH
1AH	Unused	3AH	Unused
1BH	TBC	~	
1CH	SMOD1	3FH	
1DH	Unused		
1EH	EEA		
1FH	EED		

 : Unused, read as “00”

Special Purpose Data Memory Structure

Special Function Register Description

Most of the Special Function Register details will be described in the relevant functional section, however several registers require a separate description in this section.

Indirect Addressing Registers – IAR0, IAR1

The Indirect Addressing Registers, IAR0 and IAR1, although having their locations in normal RAM register space, do not actually physically exist as normal registers. The method of indirect addressing for RAM data manipulation uses these Indirect Addressing Registers and Memory Pointers, in contrast to direct memory addressing, where the actual memory address is specified. Actions on the IAR0 and IAR1 registers will result in no actual read or write operation to these registers but rather to the memory location specified by their corresponding Memory Pointers, MP0 or MP1. Acting as a pair, IAR0 and MP0 can together access data from Bank 0 while the IAR1 and MP1 register pair can access data from any bank. As the Indirect Addressing Registers are not physically implemented, reading the Indirect Addressing Registers indirectly will return a result of “00H” and writing to the registers indirectly will result in no operation.

Memory Pointers – MP0, MP1

Two Memory Pointers, known as MP0 and MP1 are provided. These Memory Pointers are physically implemented in the Data Memory and can be manipulated in the same way as normal registers providing a convenient way with which to address and track data. When any operation to the relevant Indirect Addressing Registers is carried out, the actual address that the microcontroller is directed to is the address specified by the related Memory Pointer. MP0, together with Indirect Addressing Register, IAR0, are used to access data from Bank 0, while MP1 and IAR1 are used to access data from all banks according to BP register. Direct Addressing can only be used with Bank 0, all other Banks must be addressed indirectly using MP1 and IAR1.

The following example shows how to clear a section of four Data Memory locations already defined as locations adres1 to adres4.

Indirect Addressing Program Example

```
data .section 'data'
adres1 db ?
adres2 db ?
adres3 db ?
adres4 db ?
block db ?
code .section at 0 'code'
org00h
start:
    mov a,04h           ; setup size of block
    mov block,a
    mov a,offset adres1 ; Accumulator loaded with first RAM address
    mov mp0,a          ; setup memory pointer with first RAM address
loop:
    clr IAR0           ; clear the data at address defined by mp0
    inc mp0            ; increment memory pointer
    sdz block          ; check if last memory location has been cleared
    jmp loop
continue:
```

The important point to note here is that in the example shown above, no reference is made to specific Data Memory addresses.

Bank Pointer – BP

For this device, the Data Memory is divided into two banks, Bank0 and Bank1. Selecting the required Data Memory area is achieved using the Bank Pointer. Bit 0 of the Bank Pointer is used to select Data Memory Banks 0~1.

The Data Memory is initialised to Bank 0 after a reset, except for a WDT time-out reset in the Power Down Mode, in which case, the Data Memory bank remains unaffected. It should be noted that the Special Function Data Memory is not affected by the bank selection, which means that the Special Function Registers can be accessed from within any bank. Directly addressing the Data Memory will always result in Bank 0 being accessed irrespective of the value of the Bank Pointer. Accessing data from Bank1 must be implemented using Indirect Addressing.

• BP Register

Bit	7	6	5	4	3	2	1	0
Name	—	—	—	—	—	—	—	DMBP0
R/W	—	—	—	—	—	—	—	R/W
POR	—	—	—	—	—	—	—	0

Bit 7~1 Unimplemented, read as “0”

Bit 0 **DMBP0**: Select Data Memory Banks
 0: Bank 0
 1: Bank 1

Accumulator – ACC

The Accumulator is central to the operation of any microcontroller and is closely related with operations carried out by the ALU. The Accumulator is the place where all intermediate results from the ALU are stored. Without the Accumulator it would be necessary to write the result of each calculation or logical operation such as addition, subtraction, shift, etc., to the Data Memory resulting in higher programming and timing overheads. Data transfer operations usually involve the temporary storage function of the Accumulator; for example, when transferring data between one user-defined register and another, it is necessary to do this by passing the data through the Accumulator as no direct transfer between two registers is permitted.

Program Counter Low Byte Register – PCL

To provide additional program control functions, the low byte of the Program Counter is made accessible to programmers by locating it within the Special Purpose area of the Data Memory. By manipulating this register, direct jumps to other program locations are easily implemented. Loading a value directly into this PCL register will cause a jump to the specified Program Memory location, however, as the register is only 8-bit wide, only jumps within the current Program Memory page are permitted. When such operations are used, note that a dummy cycle will be inserted.

Look-up Table Registers – TBLP, TBLH

These two special function registers are used to control operation of the look-up table which is stored in the Program Memory. TBLP is the table pointer and indicate the location where the table data is located. Its value must be setup before any table read commands are executed. Its value can be changed, for example using the “INC” or “DEC” instructions, allowing for easy table data pointing and reading. TBLH is the location where the high order byte of the table data is stored after a table read data instruction has been executed. Note that the lower order table data byte is transferred to a user defined location.

Status Register – STATUS

This 8-bit register contains the zero flag (Z), carry flag (C), auxiliary carry flag (AC), overflow flag (OV), power down flag (PDF), and watchdog time-out flag (TO). These arithmetic/logical operation and system management flags are used to record the status and operation of the microcontroller.

With the exception of the TO and PDF flags, bits in the status register can be altered by instructions like most other registers. Any data written into the status register will not change the TO or PDF flag. In addition, operations related to the status register may give different results due to the different instruction operations. The TO flag can be affected only by a system power-up, a WDT time-out or by executing the “CLR WDT” or “HALT” instruction. The PDF flag is affected only by executing the “HALT” or “CLR WDT” instruction or during a system power-up.

The Z, OV, AC and C flags generally reflect the status of the latest operations.

- C is set if an operation results in a carry during an addition operation or if a borrow does not take place during a subtraction operation; otherwise C is cleared. C is also affected by a rotate through carry instruction.
- AC is set if an operation results in a carry out of the low nibbles in addition, or no borrow from the high nibble into the low nibble in subtraction; otherwise AC is cleared.
- Z is set if the result of an arithmetic or logical operation is zero; otherwise Z is cleared.
- OV is set if an operation results in a carry into the highest-order bit but not a carry out of the highest-order bit, or vice versa; otherwise OV is cleared.
- PDF is cleared by a system power-up or executing the “CLR WDT” instruction. PDF is set by executing the “HALT” instruction.
- TO is cleared by a system power-up or executing the “CLR WDT” or “HALT” instruction. TO is set by a WDT time-out.

In addition, on entering an interrupt sequence or executing a subroutine call, the status register will not be pushed onto the stack automatically. If the contents of the status registers are important and if the subroutine can corrupt the status register, precautions must be taken to correctly save it.

• STATUS Register

Bit	7	6	5	4	3	2	1	0
Name	—	—	TO	PDF	OV	Z	AC	C
R/W	—	—	R	R	R/W	R/W	R/W	R/W
POR	—	—	0	0	×	×	×	×

“x”: unknown

Bit 7~6 Unimplemented, read as “0”

Bit 5 **TO**: Watchdog Time-Out flag
0: After power up or executing the “CLR WDT” or “HALT” instruction
1: A watchdog time-out occurred

Bit 4 **PDF**: Power down flag
0: After power up or executing the “CLR WDT” instruction
1: By executing the “HALT” instruction

Bit 3 **OV**: Overflow flag
0: No overflow
1: An operation results in a carry into the highest-order bit but not a carry out of the highest-order bit or vice versa

Bit 2 **Z**: Zero flag
0: The result of an arithmetic or logical operation is not zero
1: The result of an arithmetic or logical operation is zero

- Bit 1 **AC:** Auxiliary flag
 0: No auxiliary carry
 1: An operation results in a carry out of the low nibbles in addition, or no borrow from the high nibble into the low nibble in subtraction
- Bit 0 **C:** Carry flag
 0: No carry-out
 1: An operation results in a carry during an addition operation or if a borrow does not take place during a subtraction operation
 C is also affected by a rotate through carry instruction.

EEPROM Data Memory

This device contains an area of internal EEPROM Data Memory. EEPROM, which is by its nature a non-volatile form of memory, with data retention even when its power supply is removed. By incorporating this kind of data memory, a whole new host of application possibilities are made available to the designer. The availability of EEPROM storage allows information such as product identification numbers, calibration values, specific user data, system setup data or other product information to be stored directly within the product microcontroller. The process of reading and writing data to the EEPROM memory has been reduced to a very trivial affair.

EEPROM Data Memory Structure

The EEPROM Data Memory capacity is 32×8 bits for this device. Unlike the Program Memory and RAM Data Memory, the EEPROM Data Memory is not directly mapped and is therefore not directly accessible in the same way as the other types of memory. Read and Write operations to the EEPROM are carried out in single byte operations using two address registers and one data register in Bank 0 and a single control register in Bank 1.

EEPROM Registers

Three registers control the overall operation of the internal EEPROM Data Memory. These are the address registers, EEA, the data register, EED and a single control register, EEC. As both the EEA and EED registers are located in Bank 0, they can be directly accessed in the same way as any other Special Function Register. The EEC register however, being located in Bank1, cannot be directly addressed directly and can only be read from or written to indirectly using the MP1 Memory Pointer and Indirect Addressing Register, IAR1. Because the EEC control register is located at address 40H in Bank 1, the MP1 Memory Pointer must first be set to the value 40H and the Bank Pointer register, BP, set to the value, 01H, before any operations on the EEC register are executed.

Name	Bit							
	7	6	5	4	3	2	1	0
EEA	—	—	—	D4	EEA4	EEA3	EEA2	EEA1
EED	D7	D6	D5	D4	D3	D2	D1	D0
EEC	—	—	—	—	WREN	WR	RDEN	RD

EEPROM Control Register List

• EEA Register

Bit	7	6	5	4	3	2	1	0
Name	—	—	—	D4	EEA4	EEA3	EEA2	EEA1
R/W	—	—	—	R/W	R/W	R/W	R/W	R/W
POR	—	—	—	0	0	0	0	0

Bit 7~5 Unimplemented, read as “0”

Bit 4~0 Data EEPROM address
Data EEPROM address bit 4 ~ bit 0

• **EED Register**

Bit	7	6	5	4	3	2	1	0
Name	D7	D6	D5	D4	D3	D2	D1	D0
R/W	R/W	R/W	R/W	R/W	R/W	R/W	R/W	R/W
POR	0	0	0	0	0	0	0	0

Bit 7~0 Data EEPROM data
Data EEPROM data bit 7 ~ bit 0

• **EEC Register**

Bit	7	6	5	4	3	2	1	0
Name	—	—	—	—	WREN	WR	RDEN	RD
R/W	—	—	—	—	R/W	R/W	R/W	R/W
POR	—	—	—	—	0	0	0	0

Bit 7~4 Unimplemented, read as “0”

Bit 3 **WREN**: Data EEPROM Write Enable
0: Disable
1: Enable

This is the Data EEPROM Write Enable Bit which must be set high before Data EEPROM write operations are carried out. Clearing this bit to zero will inhibit Data EEPROM write operations.

Bit 2 **WR**: EEPROM Write Control
0: Write cycle has finished
1: Activate a write cycle

This is the Data EEPROM Write Control Bit and when set high by the application program will activate a write cycle. This bit will be automatically reset to zero by the hardware after the write cycle has finished. Setting this bit high will have no effect if the WREN has not first been set high.

Bit 1 **RDEN**: Data EEPROM Read Enable
0: Disable
1: Enable

This is the Data EEPROM Read Enable Bit which must be set high before Data EEPROM read operations are carried out. Clearing this bit to zero will inhibit Data EEPROM read operations.

Bit 0 **RD**: EEPROM Read Control
0: Read cycle has finished
1: Activate a read cycle

This is the Data EEPROM Read Control Bit and when set high by the application program will activate a read cycle. This bit will be automatically reset to zero by the hardware after the read cycle has finished. Setting this bit high will have no effect if the RDEN has not first been set high.

Note: 1. The WREN, WR, RDEN and RD can not be set to “1” at the same time in one instruction. The WR and RD can not be set to “1” at the same time.

2. Ensure that the f_{SUB} clock is stable before executing the write operation.

3. Ensure that the write operation is totally complete before changing the contents of the EEPROM related registers.

Reading Data from the EEPROM

To read data from the EEPROM, the read enable bit, RDEN, in the EEC register must first be set high to enable the read function. The EEPROM address of the data to be read must then be placed in the EEA register. If the RD bit in the EEC register is now set high, a read cycle will be initiated. Setting the RD bit high will not initiate a read operation if the RDEN bit has not been set. When the read cycle terminates, the RD bit will be automatically cleared to zero, after which the data can be read from the EED register. The data will remain in the EED register until another read or write operation is executed. The application program can poll the RD bit to determine when the data is valid for reading.

Writing Data to the EEPROM

The EEPROM address of the data to be written must first be placed in the EEA register and the data placed in the EED register. To write data to the EEPROM, the write enable bit, WREN, in the EEC register must first be set high to enable the write function. After this, the WR bit in the EEC register must be immediately set high to initiate a write cycle. These two instructions must be executed in two consecutive instruction cycles. The global interrupt bit EMI should also first be cleared before implementing any write operations, and then set again after the write cycle has started. Note that setting the WR bit high will not initiate a write cycle if the WREN bit has not been set. As the EEPROM write cycle is controlled using an internal timer whose operation is asynchronous to microcontroller system clock, a certain time will elapse before the data will have been written into the EEPROM. Detecting when the write cycle has finished can be implemented either by polling the WR bit in the EEC register or by using the EEPROM interrupt. When the write cycle terminates, the WR bit will be automatically cleared to zero by the microcontroller, informing the user that the data has been written to the EEPROM. The application program can therefore poll the WR bit to determine when the write cycle has ended.

Write Protection

Protection against inadvertent write operation is provided in several ways. After the device is powered-on the Write Enable bit in the control register will be cleared preventing any write operations. Also at power-on the Bank Pointer, BP, will be reset to zero, which means that Data Memory Bank 0 will be selected. As the EEPROM control register is located in Bank 1, this adds a further measure of protection against spurious write operations. During normal program operation, ensuring that the Write Enable bit in the control register is cleared will safeguard against incorrect write operations.

EEPROM Interrupt

The EEPROM write interrupt is generated when an EEPROM write cycle has ended. The EEPROM interrupt must first be enabled by setting the DEE bit in the relevant interrupt register. When an EEPROM write cycle ends, the DEF request flag will be set. If the global, EEPROM Interrupt are enabled and the stack is not full, a subroutine call to the EEPROM Interrupt vector, will take place. When the EEPROM Interrupt is serviced, the EEPROM Interrupt flag DEF will be automatically cleared. The EMI bit will also be automatically cleared to disable other interrupts.

Programming Considerations

Care must be taken that data is not inadvertently written to the EEPROM. Protection can be Periodic by ensuring that the Write Enable bit is normally cleared to zero when not writing. Also the Bank Pointer could be normally cleared to zero as this would inhibit access to Bank 1 where the EEPROM control register exist. Although certainly not necessary, consideration might be given in the application program to the checking of the validity of new write data by a simple read back process. When writing data the WR bit must be set high immediately after the WREN bit has been set high, to ensure the write cycle executes correctly. The global interrupt bit EMI should also be cleared before a write cycle is executed and then re-enabled after the write cycle starts. Note that the device should not enter the IDLE or SLEEP mode until the EEPROM read or write operation is totally complete. Otherwise, the EEPROM read or write operation will fail.

Programming Examples

Reading Data from the EEPROM – Polling Method

```

MOV A, EEPROM_ADRES      ; user defined address
MOV EEA, A
MOV A, 40H                ; setup memory pointer MP1
MOV MP1, A                ; MP1 points to EEC register
MOV A, 01H                ; setup Bank Pointer
MOV BP, A
SET IAR1.1                ; set RDEN bit, enable read operations
SET IAR1.0                ; start Read Cycle - set RD bit
BACK:
SZ IAR1.0                 ; check for read cycle end
JMP BACK
CLR IAR1                  ; disable EEPROM read if no more read operations are required
CLR BP
MOV A, EED                ; move read data to register
MOV READ_DATA, A
    
```

Note: For each read operation, the address register should be re-specified followed by setting the RD bit high to activate a read cycle even if the target address is consecutive.

Writing Data to the EEPROM – Polling Method

```

MOV A, EEPROM_ADRES      ; user defined address
MOV EEA, A
MOV A, EEPROM_DATA        ; user defined data
MOV EED, A
MOV A, 40H                ; setup memory pointer MP1
MOV MP1, A                ; MP1 points to EEC register
MOV A, 01H                ; setup Bank Pointer
MOV BP, A
CLR EMI
SET IAR1.3                ; set WREN bit, enable write operations
SET IAR1.2                ; start Write Cycle - set WR bit- executed immediately after
                        ; set WREN bit

SET EMI
BACK:
SZ IAR1.2                 ; check for write cycle end
JMP BACK
CLR BP
    
```

Oscillators

Various oscillator options offer the user a wide range of functions according to their various application requirements. The flexible features of the oscillator functions ensure that the best optimisation can be achieved in terms of speed and power saving. Oscillator selections and operation are selected through registers.

Oscillator Overview

In addition to being the source of the main system clock the oscillators also provide clock sources for the Watchdog Timer and Time Base Interrupts. Two fully integrated internal oscillators, requiring no external components, are provided to form a wide range of both fast and slow system oscillators. The higher frequency oscillator provides higher performance but carry with it the disadvantage of higher power requirements, while the opposite is of course true for the lower frequency oscillator. With the capability of dynamically switching between fast and slow system clock, the device has the flexibility to optimize the performance/power ratio, a feature especially important in power sensitive portable applications.

Type	Name	Freq.
Internal High Speed RC	HIRC	8MHz
Internal Low Speed RC	LIRC	32kHz

Oscillator Types

System Clock Configurations

There are two methods of generating the system clock, a high speed oscillator and a low speed oscillator. The high speed oscillator is the internal 8MHz RC oscillator. The low speed oscillator is the internal 32kHz RC oscillator. Selecting whether the low or high speed oscillator is used as the system oscillator is implemented using the HLCLK bit and CKS2 ~ CKS0 bits in the SMOD register and as the system clock can be dynamically selected.

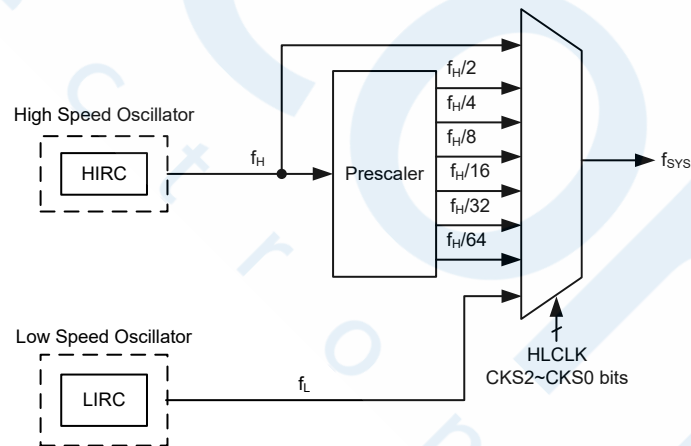

System Clock Configurations

Internal High Speed RC Oscillator – HIRC

The internal RC oscillator is a fully integrated system oscillator requiring no external components. The internal RC oscillator has a fixed frequency of 8MHz. Device trimming during the manufacturing process and the inclusion of internal frequency compensation circuits are used to ensure that the influence of the power supply voltage, temperature and process variations on the oscillation frequency are minimised.

Internal 32kHz Oscillator – LIRC

The internal 32kHz System Oscillator is the low frequency oscillator. It is a fully integrated RC oscillator with a typical frequency of 32kHz, requiring no external components for its implementation. Device trimming during the manufacturing process and the inclusion of internal frequency compensation circuits are used to ensure that the influence of the power supply voltage, temperature and process variations on the oscillation frequency are minimised.

Supplementary Oscillator

The low speed oscillator, in addition to providing a system clock source is also used to provide a clock source to two other device functions. These are the Watchdog Timer and the Time Base Interrupts.

Operating Modes and System Clocks

Present day applications require that their microcontrollers have high performance but often still demand that they consume as little power as possible, conflicting requirements that are especially true in battery powered portable applications. The fast clocks required for high performance will by their nature increase current consumption and of course vice-versa, lower speed clocks reduce current consumption. As Holtek has provided the device with both high and low speed clock sources and the means to switch between them dynamically, the user can optimise the operation of their microcontroller to achieve the best performance/power ratio.

System Clocks

This device has two different clock sources for both the CPU and peripheral function operation. By providing the user with clock options using register programming, a clock system can be configured to obtain maximum application performance.

The main system clock, can come from either a high frequency, f_H , or a low frequency, f_L , and is selected using the HLCLK bit and CKS2~CKS0 bits in the SMOD register. The high speed system clock is sourced from the HIRC oscillator. The low speed system clock source is sourced from the LIRC oscillator. The other choice, which is a divided version of the high speed system oscillator has a range of $f_H/2 \sim f_H/64$.

There is one additional internal clock for the peripheral circuits, the Time Base clock, f_{TBC} . f_{TBC} is sourced from the LIRC oscillator. The f_{TBC} clock is used as a source for the Time Base interrupt functions and for the TMs.

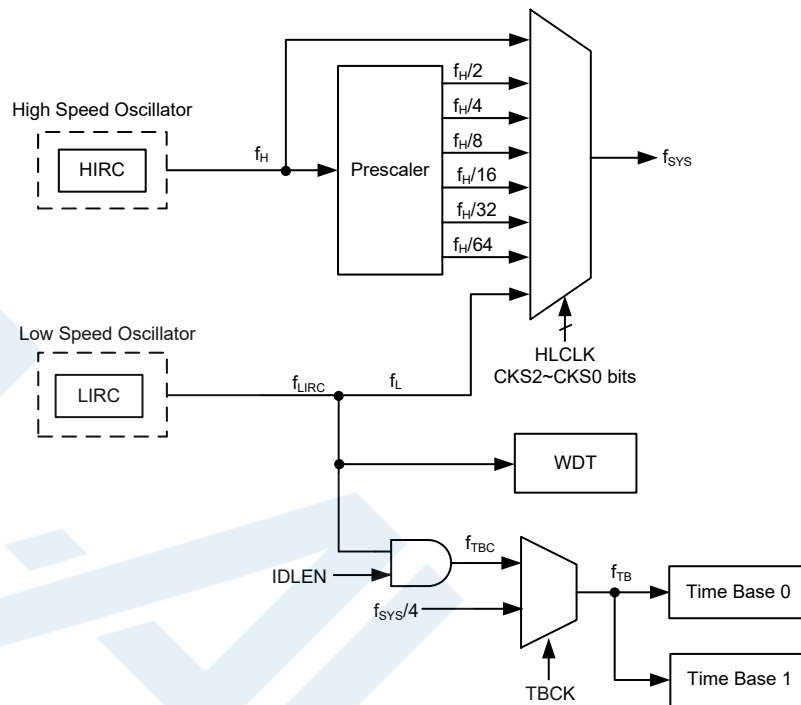

System Clock Configurations

Note: When the system clock source f_{SYS} is switched to f_L from f_H , the high speed oscillation will stop to conserve the power. Thus there is no $f_H \sim f_H/64$ for peripheral circuit to use.

System Operation Modes

There are six different modes of operation for the microcontroller, each one with its own special characteristics and which can be chosen according to the specific performance and power requirements of the application. There are two modes allowing normal operation of the microcontroller, the NORMAL Mode and SLOW Mode. The remaining four modes, the SLEEP0, SLEEP1, IDLE0 and IDLE1 modes are used when the microcontroller CPU is switched off to conserve power.

Operating Mode	Description			
	CPU	f_{SYS}	f_{LIRC}	f_{TBC}
NORMAL mode	On	$f_H \sim f_H/64$	On	On
SLOW mode	On	f_L	On	On
IDLE0 mode	Off	Off	On	On
IDLE1 mode	Off	On	On	On
SLEEP0 mode	Off	Off	Off	Off
SLEEP1 mode	Off	Off	On	Off

NORMAL Mode

As the name suggests this is one of the main operating modes where the microcontroller has all of its functions operational and where the system clock is provided by the high speed oscillator. This mode operates allowing the microcontroller to operate normally with a clock source which will come from the high speed oscillator HIRC. The high speed oscillator will however first be divided by a ratio ranging from 1 to 64, the actual ratio being selected by the CKS2~CKS0 and HLCLK bits in the SMOD register. Although a high speed oscillator is used, running the microcontroller at a divided clock ratio reduces the operating current.

SLOW Mode

This is also a mode where the microcontroller operates normally although now with a slower speed clock source. The clock source used will be from the low speed oscillator LIRC. Running the microcontroller in this mode allows it to run with much lower operating currents. In the SLOW Mode, the f_H is off.

SLEEP0 Mode

The SLEEP Mode is entered when a HALT instruction is executed and when the IDLEN bit in the SMOD register is low. In the SLEEP0 mode the CPU will be stopped, and the f_{LIRC} clock will be stopped too, and the Watchdog Timer function is disabled.

SLEEP1 Mode

The SLEEP Mode is entered when a HALT instruction is executed and when the IDLEN bit in the SMOD register is low. In the SLEEP1 mode the CPU will be stopped. However the f_{LIRC} clock will continue to operate if the Watchdog Timer function is enabled.

IDLE0 Mode

The IDLE0 Mode is entered when a HALT instruction is executed and when the IDLEN bit in the SMOD register is high and the FSYSOEN bit in the SMOD1 register is low. In the IDLE0 Mode the system oscillator will be inhibited from driving the CPU but some peripheral functions will remain operational such as the Watchdog Timer and TMs. In the IDLE0 Mode, the system oscillator will be stopped.

IDLE1 Mode

The IDLE1 Mode is entered when a HALT instruction is executed and when the IDLEN bit in the SMOD register is high and the FSYSOEN bit in the SMOD1 register is high. In the IDLE1 Mode the system oscillator will be inhibited from driving the CPU but may continue to provide a clock source to keep some peripheral functions operational such as the Watchdog Timer and TMs. In the IDLE1 Mode, the system oscillator will continue to run, and this system oscillator may be a high speed or low speed system oscillator. In the IDLE1 Mode, the Watchdog Timer clock, f_{LIRC} , will be on.

Control Register

A single register, SMOD, is used for overall control of the internal clocks within the device.

• SMOD Register

Bit	7	6	5	4	3	2	1	0
Name	CKS2	CKS1	CKS0	—	LTO	HTO	IDLEN	HLCLK
R/W	R/W	R/W	R/W	—	R	R	R/W	R/W
POR	0	0	0	—	0	0	1	1

Bit 7~5 **CKS2 ~ CKS0:** The system clock selection when HLCLK is "0"

000: f_L (f_{LIRC})
 001: f_L (f_{LIRC})
 010: $f_H/64$
 011: $f_H/32$
 100: $f_H/16$
 101: $f_H/8$
 110: $f_H/4$
 111: $f_H/2$

These three bits are used to select which clock is used as the system clock source. In addition to the system clock source, which can be the LIRC, a divided version of the high speed system oscillator can also be chosen as the system clock source.

- Bit 4 Unimplemented, read as “0”
- Bit 3 **LTO**: Low speed system oscillator ready flag
 0: Not ready
 1: Ready

This is the low speed system oscillator ready flag which indicates when the low speed system oscillator is stable after power on reset or a wake-up has occurred. The flag will be low when in the SLEEP0 mode, but after a wake-up has occurred the flag will change to a high level after 1~2 cycles if the LIRC oscillator is used.

- Bit 2 **HTO**: High speed system oscillator ready flag
 0: Not ready
 1: Ready

This is the high speed system oscillator ready flag which indicates when the high speed system oscillator is stable. This flag is cleared to “0” by hardware when the device is powered on and then changes to a high level after the high speed system oscillator is stable. Therefore this flag will always be read as “1” by the application program after device power-on.

- Bit 1 **IDLEN**: IDLE Mode Control
 0: Disable
 1: Enable

This is the IDLE Mode Control bit and determines what happens when the HALT instruction is executed. If this bit is high, when a HALT instruction is executed the device will enter the IDLE Mode. In the IDLE1 Mode the CPU will stop running but the system clock will continue to keep the peripheral functions operational, if FSYSON bit is high. If FSYSON bit is low, the CPU and the system clock will all stop in IDLE0 mode. If the bit is low the device will enter the SLEEP Mode when a HALT instruction is executed.

- Bit 0 **HLCLK**: System Clock Selection
 0: $f_H/2 \sim f_H/64$ or f_L
 1: f_H

This bit is used to select if the f_H clock or the $f_H/2 \sim f_H/64$ or f_L clock is used as the system clock. When the bit is high the f_H clock will be selected and if low the $f_H/2 \sim f_H/64$ or f_L clock will be selected. When system clock switches from the f_H clock to the f_L clock and the f_H clock will be automatically switched off to conserve power.

• **SMOD1 Register**

Bit	7	6	5	4	3	2	1	0
Name	FSYSON	—	—	—	D3	LVRF	—	WRF
R/W	R/W	—	—	—	R/W	R/W	—	R/W
POR	0	—	—	—	0	x	—	0

“x” unknown

- Bit 7 **FSYSON**: f_{SYS} Control in IDLE Mode
 0: Disable
 1: Enable
- Bit 6~4 Unimplemented, read as “0”
- Bit 3 **D3**: Reserved bit
- Bit 2 **LVRF**: LVR function reset flag
 Described elsewhere
- Bit 1 Unimplemented, read as “0”
- Bit 0 **WRF**: WDT Control register software reset flag
 Described elsewhere

Operating Mode Switching

The device can switch between operating modes dynamically allowing the user to select the best performance/power ratio for the present task in hand. In this way microcontroller operations that do not require high performance can be executed using slower clocks thus requiring less operating current and prolonging battery life in portable applications.

In simple terms, Mode Switching between the NORMAL Mode and SLOW Mode is executed using the HLCLK bit and CKS2~CKS0 bits in the SMOD register while Mode Switching from the NORMAL/SLOW Modes to the SLEEP/IDLE Modes is executed via the a HALT instruction. When a HALT instruction is executed, whether the device enters the IDLE Mode or the SLEEP Mode is determined by the condition of the IDLEN bit in the SMOD register and FSYSON in the SMOD1 register.

When the HLCLK bit switches to a low level, which implies that clock source is switched from the high speed clock source, f_H , to the clock source, $f_H/2 \sim f_H/64$ or f_L . If the clock is from the f_L , the high speed clock source will stop running to conserve power. When this happens it must be noted that the $f_H/16$ and $f_H/64$ internal clock sources will also stop running, which may affect the operation of other internal functions such as the TMs.

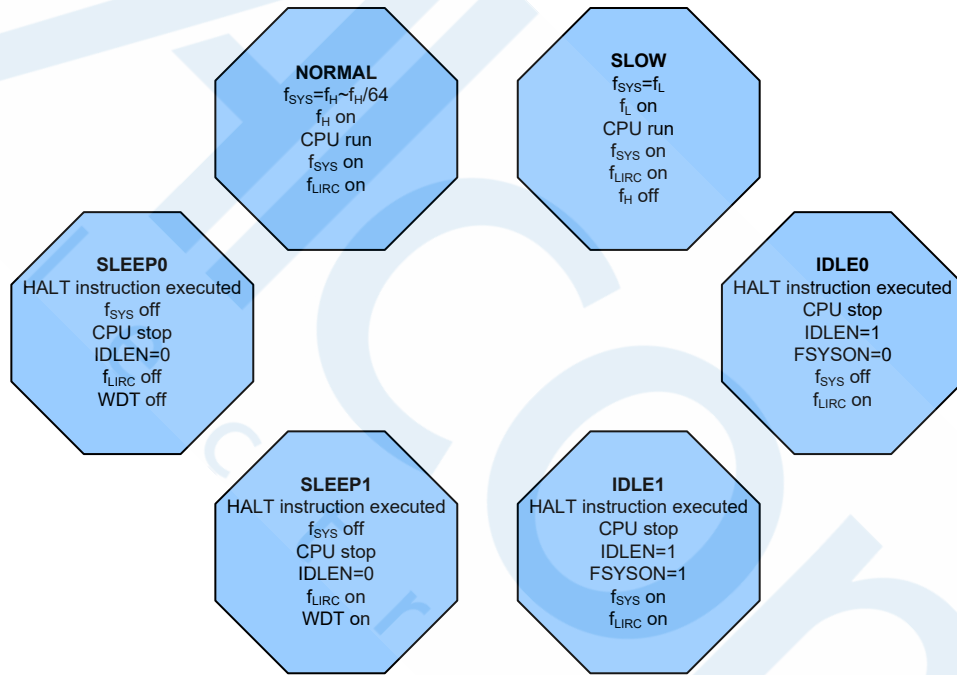

NORMAL Mode to SLOW Mode Switching

When running in the NORMAL Mode, which uses the high speed system oscillator, and therefore consumes more power, the system clock can switch to run in the SLOW Mode by setting the HLCLK bit to “0” and setting the CKS2~CKS0 bits to “000” or “001” in the SMOD register. This will then use the low speed system oscillator which will consume less power. Users may decide to do this for certain operations which do not require high performance and can subsequently reduce power consumption.

The SLOW Mode system clock is sourced from the LIRC oscillator and therefore requires this oscillator to be stable before full mode switching occurs. This is monitored using the LTO bit in the SMOD register.

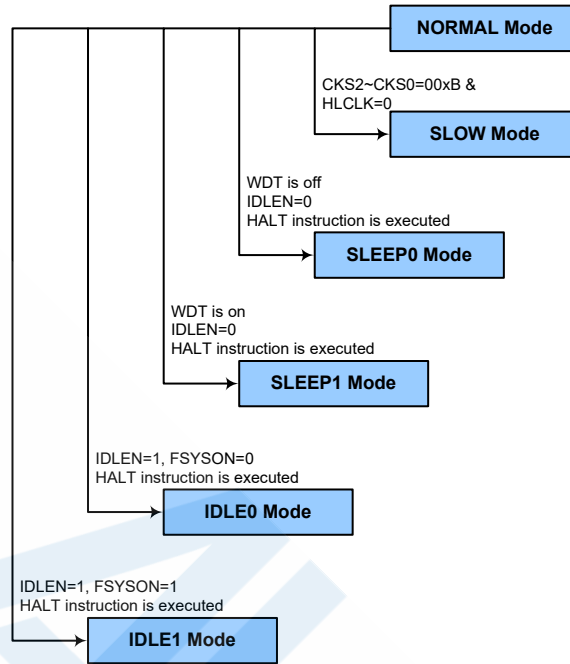

SLOW Mode to NORMAL Mode Switching

In SLOW Mode the system uses LIRC low speed system oscillator. To switch back to the NORMAL Mode, where the high speed system oscillator is used, the HLCLK bit should be set to “1” or HLCLK bit is “0”, but CKS2~CKS0 is set to “010”, “011”, “100”, “101”, “110” or “111”. As a certain amount of time will be required for the high frequency clock to stabilise, the status of the HTO bit is checked.

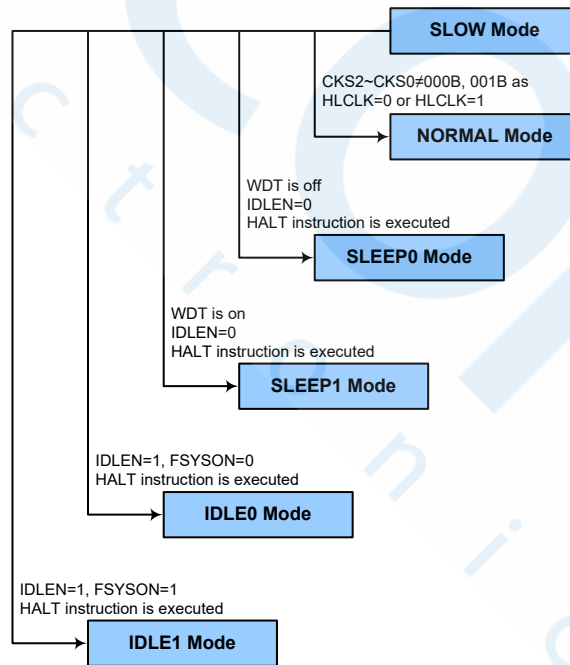

Entering the SLEEP0 Mode

There is only one way for the device to enter the SLEEP0 Mode and that is to execute the “HALT” instruction in the application program with the IDLEN bit in SMOD register equal to “0” and the WDT off. When this instruction is executed under the conditions described above, the following will occur:

- The system clock, WDT clock and Time Base clock will be stopped and the application program will stop at the “HALT” instruction.
- The Data Memory contents and registers will maintain their present condition.
- The WDT will be cleared and stopped.
- The I/O ports will maintain their present conditions.
- In the status register, the Power Down flag, PDF, will be set and the Watchdog time-out flag, TO, will be cleared.

Entering the SLEEP1 Mode

There is only one way for the device to enter the SLEEP1 Mode and that is to execute the “HALT” instruction in the application program with the IDLEN bit in SMOD register equal to “0” and the WDT on. When this instruction is executed under the conditions described above, the following will occur:

- The system clock and Time Base clock will be stopped and the application program will stop at the “HALT” instruction, but the WDT will remain with the clock source coming from the f_{LIRC} clock.
- The Data Memory contents and registers will maintain their present condition.
- The WDT will be cleared and resume counting if the WDT is enabled.
- The I/O ports will maintain their present conditions.
- In the status register, the Power Down flag, PDF, will be set and the Watchdog time-out flag, TO, will be cleared.

Entering the IDLE0 Mode

There is only one way for the device to enter the IDLE0 Mode and that is to execute the “HALT” instruction in the application program with the IDLEN bit in SMOD register equal to “1” and the FSYSON bit in SMOD1 register equal to “0”. When this instruction is executed under the conditions described above, the following will occur:

- The system clock will be stopped and the application program will stop at the “HALT” instruction, but the Time Base clock will be on.
- The Data Memory contents and registers will maintain their present condition.
- The WDT will be cleared and resume counting if the WDT is enabled.
- The I/O ports will maintain their present conditions.
- In the status register, the Power Down flag, PDF, will be set and the Watchdog time-out flag, TO, will be cleared.

Entering the IDLE1 Mode

There is only one way for the device to enter the IDLE1 Mode and that is to execute the “HALT” instruction in the application program with the IDLEN bit in SMOD register equal to “1” and the FSYSON bit in SMOD1 register equal to “1”. When this instruction is executed under the conditions described above, the following will occur:

- The system clock and Time Base clock will be on and the application program will stop at the “HALT” instruction.
- The Data Memory contents and registers will maintain their present condition.

- The WDT will be cleared and resume counting if the WDT is enabled.
- The I/O ports will maintain their present conditions.
- In the status register, the Power Down flag, PDF, will be set and the Watchdog time-out flag, TO, will be cleared.

Standby Current Considerations

As the main reason for entering the SLEEP or IDLE Mode is to keep the current consumption of the device to as low a value as possible, perhaps only in the order of several micro-amps except in the IDLE1 Mode, there are other considerations which must also be taken into account by the circuit designer if the power consumption is to be minimised. Special attention must be made to the I/O pins on the device. All high-impedance input pins must be connected to either a fixed high or low level as any floating input pins could create internal oscillations and result in increased current consumption. This also applies to device which have different package types, as there may be unbonbed pins. These must either be setup as outputs or if setup as inputs must have pull-high resistors connected.

Care must also be taken with the loads, which are connected to I/O pins, which are setup as outputs. These should be placed in a condition in which minimum current is drawn or connected only to external circuits that do not draw current, such as other CMOS inputs. In the IDLE1 Mode the system oscillator is on, if the system oscillator is from the high speed system oscillator, the additional standby current will also be perhaps in the order of several hundred micro-amps.

Wake-up

After the system enters the SLEEP or IDLE Mode, it can be woken up from one of various sources listed as follows:

- An external reset
- An external falling edge on Port A
- A system interrupt
- A WDT overflow

If the system is woken up by an external reset, the device will experience a full system reset, however, If the device is woken up by a WDT overflow, a Watchdog Timer reset will be initiated. Although both of these wake-up methods will initiate a reset operation, the actual source of the wake-up can be determined by examining the TO and PDF flags. The PDF flag is cleared by a system power-up or executing the clear Watchdog Timer instruction and is set when executing the “HALT” instruction. The TO flag is set if a WDT time-out occurs, and causes a wake-up that only resets the Program Counter and Stack Pointer, the other flags remain in their original status.

Each pin on Port A can be setup using the PAWU register to permit a negative transition on the pin to wake-up the system. When a Port A pin wake-up occurs, the program will resume execution at the instruction following the “HALT” instruction. If the system is woken up by an interrupt, then two possible situations may occur. The first is where the related interrupt is disabled or the interrupt is enabled but the stack is full, in which case the program will resume execution at the instruction following the “HALT” instruction. In this situation, the interrupt which woke-up the device will not be immediately serviced, but will rather be serviced later when the related interrupt is finally enabled or when a stack level becomes free. The other situation is where the related interrupt is enabled and the stack is not full, in which case the regular interrupt response takes place. If an interrupt request flag is set high before entering the SLEEP or IDLE Mode, the wake-up function of the related interrupt will be disabled.

Watchdog Timer

The Watchdog Timer is provided to prevent program malfunctions or sequences from jumping to unknown locations, due to certain uncontrollable external events such as electrical noise.

Watchdog Timer Clock Source

The Watchdog Timer clock source is provided by the internal f_{LIRC} clock which is supplied by the LIRC oscillator. The Watchdog Timer source clock is then subdivided by a ratio of 2^8 to 2^{15} to give longer timeouts, the actual value being chosen using the WS2~WS0 bits in the WDTC register. The LIRC internal oscillator has an approximate period of 32kHz. However, it should be noted that this specified internal clock period can vary with V_{DD} , temperature and process variations. The WDT can be enabled/disabled using the WDTC register.

Watchdog Timer Control Register

A single register, WDTC, controls the required timeout period as well as the enable/disable operation. The WRF software reset flag will be indicated in the SMOD1 register. These registers control the overall operation of the Watchdog Timer.

• WDTC Register

Bit	7	6	5	4	3	2	1	0
Name	WE4	WE3	WE2	WE1	WE0	WS2	WS1	WS0
R/W	R/W	R/W	R/W	R/W	R/W	R/W	R/W	R/W
POR	0	1	0	1	0	0	1	1

Bit 7~3 **WE4~WE0**: WDT function software control

10101: WDT disable

01010: WDT enable

Other values: Reset MCU

When these bits are changed to any other values by the environmental noise to reset the microcontroller, the reset operation will be activated after 2~3 LIRC clock cycles and the WRF bit will be set to 1 to indicate the reset source.

Bit 2~0 **WS2~WS0**: WDT Time-out period selection

000: $2^8/f_{LIRC}$

001: $2^9/f_{LIRC}$

010: $2^{10}/f_{LIRC}$

011: $2^{11}/f_{LIRC}$

100: $2^{12}/f_{LIRC}$

101: $2^{13}/f_{LIRC}$

110: $2^{14}/f_{LIRC}$

111: $2^{15}/f_{LIRC}$

These three bits determine the division ratio of the Watchdog Timer source clock, which in turn determines the timeout period.

• SMOD1 Register

Bit	7	6	5	4	3	2	1	0
Name	FSYSON	—	—	—	D3	LVRF	—	WRF
R/W	R/W	—	—	—	R/W	R/W	—	R/W
POR	0	—	—	—	0	x	—	0

“x” unknown

Bit 7 **FSYSON**: f_{SYS} Control in IDLE Mode

Described elsewhere

Bit 6~4 Unimplemented, read as “0”

- Bit 3 **D3**: Reserved bit
- Bit 2 **LVRF**: LVR function reset flag
Refer to the Low Voltage Reset section.
- Bit 1 Unimplemented, read as “0”
- Bit 0 **WRF**: WDT Control register software reset flag
0: Not occurred
1: Occurred
This bit is set to 1 by the WDT Control register software reset and cleared by the application program. Note that this bit can only be cleared to 0 by the application program.

Watchdog Timer Operation

The Watchdog Timer operates by providing a device reset when its timer overflows. This means that in the application program and during normal operation the user has to strategically clear the Watchdog Timer before it overflows to prevent the Watchdog Timer from executing a reset. This is done using the clear watchdog instruction. If the program malfunctions for whatever reason, jumps to an unknown location, or enters an endless loop, the clear WDT instruction will not be executed in the correct manner, in which case the Watchdog Timer will overflow and reset the device. There are five bits, WE4~WE0, in the WDTC register to offer the Watchdog Timer enable/disable control and the MCU reset. The WDT function will be disabled when the WE4~WE0 bits are set to a value of 10101B while the WDT function will be enabled if the WE4~WE0 bits are equal to 01010B. If the WE4~WE0 bits are set to any other values, other than 01010B and 10101B, it will reset the device after 2~3 LIRC clock cycles. After power on these bits will have a value of 01010B.

WE4~WE0 Bits	WDT Function
10101B	Disable
01010B	Enable
Any other values	Reset MCU

Watchdog Timer Enable/Disable Control

Under normal program operation, a Watchdog Timer time-out will initialise a device reset and set the status bit TO. However, if the system is in the SLEEP or IDLE Mode, when a Watchdog Timer time-out occurs, the TO bit in the status register will be set and only the Program Counter and Stack Pointer will be reset. Four methods can be adopted to clear the contents of the Watchdog Timer. The first is a WDTC software reset, which means a value other than 01010B and 10101B is written into the WE4~WE0 bit locations, the second is an external hardware reset, which means a low level on the external reset pin, the third is using the Watchdog Timer software clear instruction and the fourth is via a HALT instruction. There is only one method of using software instruction to clear the Watchdog Timer. That is to use the single “CLR WDT” instruction to clear the WDT.

The maximum time-out period is when the 2^{15} division ratio is selected. As an example, with a 32kHz LIRC oscillator as its source clock, this will give a maximum watchdog period of around 1 second for the 2^{15} division ratio, and a minimum timeout of 7.8ms for the 2^8 division ration.

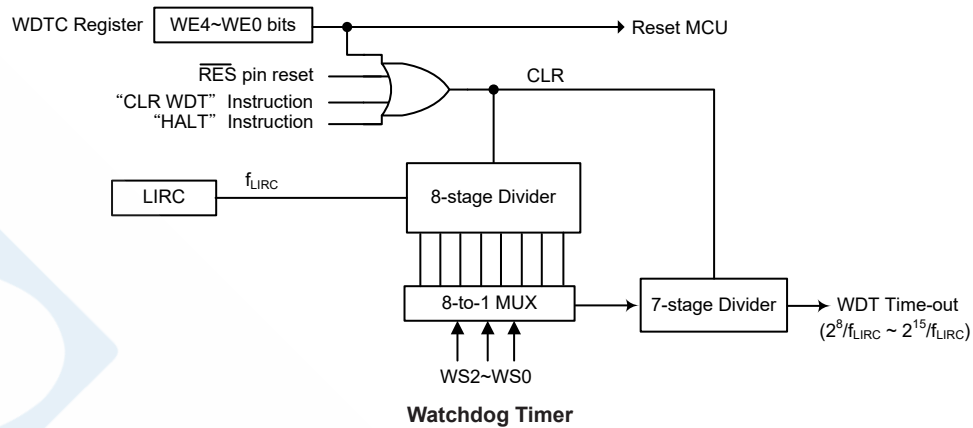

Reset and Initialisation

A reset function is a fundamental part of any microcontroller ensuring that the device can be set to some predetermined condition irrespective of outside parameters. The most important reset condition is after power is first applied to the microcontroller. In this case, internal circuitry will ensure that the microcontroller, after a short delay, will be in a well defined state and ready to execute the first program instruction. After this power-on reset, certain important internal registers will be set to defined states before the program commences. One of these registers is the Program Counter, which will be reset to zero forcing the microcontroller to begin program execution from the lowest Program Memory address.

In addition to the power-on reset, situations may arise where it is necessary to forcefully apply a reset condition when the microcontroller is running. One example of this is where after power has been applied and the microcontroller is already running, the RES line is forcefully pulled low. In such a case, known as a normal operation reset, some of the microcontroller registers remain unchanged allowing the microcontroller to proceed with normal operation after the reset line is allowed to return high.

Another type of reset is when the Watchdog Timer overflows and resets the microcontroller. All types of reset operations result in different register conditions being setup. Another reset exists in the form of a Low Voltage Reset, LVR, where a full reset is implemented in situations where the power supply voltage falls below a certain threshold.

Reset Functions

There are several ways in which a microcontroller reset can occur, through events occurring both internally and externally:

Power-on Reset

The most fundamental and unavoidable reset is the one that occurs after power is first applied to the microcontroller. As well as ensuring that the Program Memory begins execution from the first memory address, a power-on reset also ensures that certain other registers are preset to known conditions. All the I/O port and port control registers will power up in a high condition ensuring that all pins will be first set to inputs.

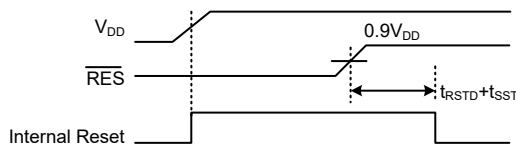

Note: t_{RSTD} is power-on delay, typical time = 50ms

Power-On Reset Timing Chart

\overline{RES} Pin Reset

Although the microcontroller has an internal RC reset function, if the V_{DD} power supply rise time is not fast enough or does not stabilise quickly at power-on, the internal reset function may be incapable of providing proper reset operation. For this reason it is recommended that an external RC network is connected to the \overline{RES} pin, whose additional time delay will ensure that the \overline{RES} pin remains low for an extended period to allow the power supply to stabilise. During this time delay, normal operation of the microcontroller will be inhibited. After the \overline{RES} line reaches a certain voltage value, the reset delay time t_{RSTD} is invoked to provide an extra delay time after which the microcontroller will begin normal operation. The abbreviation SST in the figures stands for System Start-up Timer.

For most applications a resistor connected between V_{DD} and the \overline{RES} pin and a capacitor connected between VSS and the \overline{RES} pin will provide a suitable external reset circuit. Any wiring connected to the \overline{RES} pin should be kept as short as possible to minimize any stray noise interference. For applications that operate within an environment where more noise is present the Enhanced Reset Circuit shown is recommended.

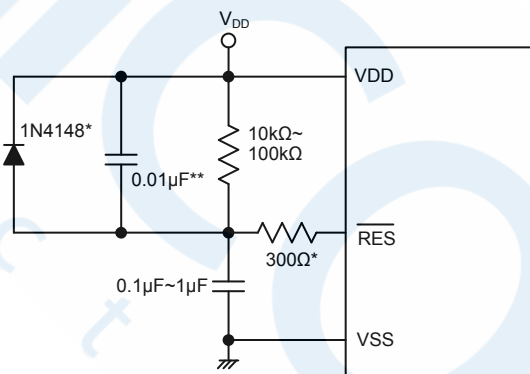

Note: “*” It is recommended that this component is added for added ESD protection

“**” It is recommended that this component is added in environments where power line noise is significant

External \overline{RES} Circuit

Pulling the \overline{RES} Pin low using external hardware will also execute a device reset. In this case, as in the case of other resets, the Program Counter will reset to zero and program execution initiated from this point.

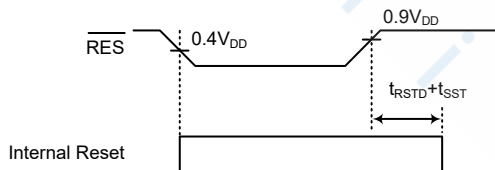

Note: t_{RSTD} is power-on delay, typical time = 16.7ms

RES Reset Timing Chart

• **RSTC External Reset Register**

Bit	7	6	5	4	3	2	1	0
Name	RSTC7	RSTC6	RSTC5	RSTC4	RSTC3	RSTC2	RSTC1	RSTC0
R/W	R/W	R/W	R/W	R/W	R	R	R/W	R/W
POR	0	1	0	1	0	1	0	1

Bit 7~0 **RSTC7~RSTC0**: PA7/ $\overline{\text{RES}}$ selection
 01010101: configured as PA7 pin or other function
 10101010: configured as $\overline{\text{RES}}$ pin
 Other Values: Inhibit to use
 All reset functions will reset this register as POR value except WDT time out Hardware warm reset.

Low Voltage Reset – LVR

The microcontroller contains a low voltage reset circuit in order to monitor the supply voltage of the device and provide an MCU reset should the value fall below a certain predefined level. The LVR function is always enabled during the normal and slow modes with a specific LVR voltage V_{LVR} . If the supply voltage of the device drops to within a range of $0.9V \sim V_{\text{LVR}}$ such as might occur when changing the battery, the LVR will automatically reset the device internally and the LVRF bit in the SMOD1 register will also be set to 1. For a valid LVR signal, a low voltage, i.e., a voltage in the range between $0.9V \sim V_{\text{LVR}}$ must exist for greater than the value t_{LVR} specified in the LVR Electrical Characteristics. If the low voltage state does not exceed this value, the LVR will ignore the low supply voltage and will not perform a reset function. The actual V_{LVR} is 1.9V, the LVR will reset the device after 2~3 LIRC clock cycles. Note that the LVR function will be automatically disabled when the device enters the SLEEP/IDLE mode.

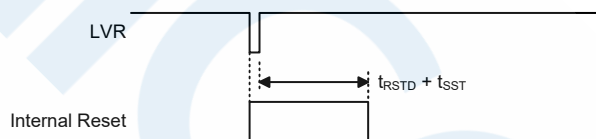

Note: t_{rSTD} is power-on delay, typical time = 50ms

Low Voltage Reset Timing Chart

• **SMOD1 Register**

Bit	7	6	5	4	3	2	1	0
Name	FSYSON	—	—	—	D3	LVRF	—	WRF
R/W	R/W	—	—	—	R/W	R/W	—	R/W
POR	0	—	—	—	0	x	—	0

“x” unknown

Bit 7 **FSYSON**: f_{SYS} Control in IDLE Mode
Described elsewhere

Bit 6~4 Unimplemented, read as “0”

Bit 3 **D3**: Reserved bit

Bit 2 **LVRF**: LVR function reset flag
 0: Not occurred
 1: Occurred
 This bit is set to 1 when the low voltage reset situation occurs. This bit can only be cleared to 0 by the application program.

Bit 1 Unimplemented, read as “0”

Bit 0 **WRF**: WDT Control register software reset flag
Refer to the Watchdog Timer Control Register section.

Watchdog Time-out Reset during Normal Operation

The Watchdog time-out Reset during normal operation is the same as an LVR reset except that the Watchdog time-out flag TO will be set to “1”.

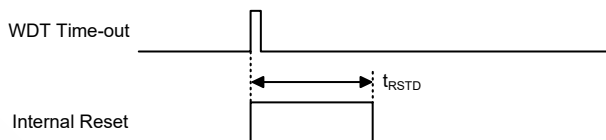

Note: t_{RSTD} is power-on delay, typical time = 16.7ms

WDT Time-out Reset during Normal Operation Timing Chart

Watchdog Time-out Reset during SLEEP or IDLE Mode

The Watchdog time-out Reset during SLEEP or IDLE Mode is a little different from other kinds of reset. Most of the conditions remain unchanged except that the Program Counter and the Stack Pointer will be cleared to “0” and the TO flag will be set to “1”. Refer to the A.C. Characteristics for t_{SST} details.

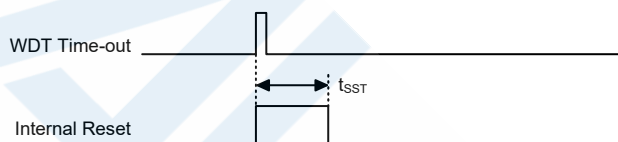

WDT Time-out Reset during SLEEP or IDLE Mode Timing Chart

Reset Initial Conditions

The different types of reset described affect the reset flags in different ways. These flags, known as PDF and TO are located in the status register and are controlled by various microcontroller operations, such as the SLEEP or IDLE Mode function or Watchdog Timer. The reset flags are shown in the table:

TO	PDF	RESET Conditions
0	0	Power-on reset
u	u	LVR reset during NORMAL or SLOW Mode operation
1	u	WDT time-out reset during NORMAL or SLOW Mode operation
1	1	WDT time-out reset during IDLE or SLEEP Mode operation

Note: “u” stands for unchanged

The following table indicates the way in which the various components of the microcontroller are affected after a power-on reset occurs.

Item	Condition After RESET
Program Counter	Reset to zero
Interrupts	All interrupts will be disabled
WDT, Time Bases	Cleared after reset, WDT begins counting
Timer Modules	Timer Modules will be turned off
Input/Output Ports	I/O ports will be setup as inputs
Stack Pointer	Stack Pointer will point to the top of the stack

The different kinds of resets all affect the internal registers of the microcontroller in different ways. To ensure reliable continuation of normal program execution after a reset occurs, it is important to know what condition the microcontroller is in after a particular reset occurs. The following table describes how each type of reset affects each of the microcontroller internal registers.

Register	Power-on Reset	WDT Time-out (Normal Operation)	RES Reset (Normal Operation)	RES Reset (HALT)	WDT Time-out (HALT)
PC	000H	000H	000H	000H	000H
MP0	1xxx xxxx	1xxx xxxx	1xxx xxxx	1xxx xxxx	1uuu uuuu
MP1	1xxx xxxx	1xxx xxxx	1xxx xxxx	1xxx xxxx	1uuu uuuu
BP	---- --0	---- --0	---- --0	---- --0	---- --u
ACC	xxxx xxxx	uuuu uuuu	uuuu uuuu	uuuu uuuu	uuuu uuuu
PCL	0000 0000	0000 0000	0000 0000	0000 0000	0000 0000
TBLP	xxxx xxxx	uuuu uuuu	uuuu uuuu	uuuu uuuu	uuuu uuuu
TBLH	--xx xxxx	--uu uuuu	--uu uuuu	--uu uuuu	--uu uuuu
STATUS	--00 xxxx	--1u uuuu	--uu uuuu	--01 uuuu	--11 uuuu
SMOD	000- 0011	000- 0011	000- 0011	000- 0011	uuu- uuuu
INTEG	---- --00	---- --00	---- --00	---- --00	---- --uu
INTC0	-000 0000	-000 0000	-000 0000	-000 0000	-uuu uuuu
INTC1	0000 0000	0000 0000	0000 0000	0000 0000	uuuu uuuu
MFIO	--00 --00	--00 --00	--00 --00	--00 --00	--uu --uu
MF11	--00 --00	--00 --00	--00 --00	--00 --00	--uu --uu
PA	1111 1111	1111 1111	1111 1111	1111 1111	uuuu uuuu
PAC	1111 1111	1111 1111	1111 1111	1111 1111	uuuu uuuu
PAPU	0000 0000	0000 0000	0000 0000	0000 0000	uuuu uuuu
PAWU	0000 0000	0000 0000	0000 0000	0000 0000	uuuu uuuu
IFS0	0000 0-00	0000 0-00	0000 0-00	0000 0-00	uuuu u-uu
WDTC	0101 0011	0101 0011	0101 0011	0101 0011	uuuu uuuu
TBC	0011 -111	0011 -111	0011 -111	0011 -111	uuuu -uuu
EEA	---0 0000	---0 0000	---0 0000	---0 0000	---u uuuu
EED	0000 0000	0000 0000	0000 0000	0000 0000	uuuu uuuu
SADOL (ADRF5=0)	xxxx ----	xxxx ----	xxxx ----	xxxx ----	uuuu ----
SADOL (ADRF5=1)	xxxx xxxx	xxxx xxxx	xxxx xxxx	xxxx xxxx	uuuu uuuu
SAD0H (ADRF5=0)	xxxx xxxx	xxxx xxxx	xxxx xxxx	xxxx xxxx	uuuu uuuu
SAD0H (ADRF5=1)	---- xxxx	---- xxxx	---- xxxx	---- xxxx	---- uuuu
SADC0	0000 --00	0000 --00	0000 --00	0000 --00	uuuu --uu
SADC1	000- -000	000- -000	000- -000	000- -000	uuu- -uuu
SADC2	00-- 0000	00-- 0000	00-- 0000	00-- 0000	uu-- uuuu
RSTC	0101 0101	0101 0101	0101 0101	0101 0101	uuuu uuuu
PASR	0000 0000	0000 0000	0000 0000	0000 0000	uuuu uuuu
PBSR	--00 0000	--00 0000	--00 0000	--00 0000	--uu uuuu
STM0C0	0000 0000	0000 0000	0000 0000	0000 0000	uuuu uuuu
STM0C1	0000 0000	0000 0000	0000 0000	0000 0000	uuuu uuuu
STM0DL	0000 0000	0000 0000	0000 0000	0000 0000	uuuu uuuu
STM0DH	---- --00	---- --00	---- --00	---- --00	---- --uu
STM0AL	0000 0000	0000 0000	0000 0000	0000 0000	uuuu uuuu

Register	Power-on Reset	WDT Time-out (Normal Operation)	RES Reset (Normal Operation)	$\overline{\text{RES}}$ Reset (HALT)	WDT Time-out (HALT)
STM0AH	---- --00	---- --00	---- --00	---- --00	---- --uu
PTM1C0	0000 0---	0000 0---	0000 0---	0000 0---	uuuu u---
PTM1C1	0000 0000	0000 0000	0000 0000	0000 0000	uuuu uuuu
PTM1DL	0000 0000	0000 0000	0000 0000	0000 0000	uuuu uuuu
PTM1DH	---- --00	---- --00	---- --00	---- --00	---- --uu
PTM1AL	0000 0000	0000 0000	0000 0000	0000 0000	uuuu uuuu
PTM1AH	---- --00	---- --00	---- --00	---- --00	---- --uu
PTM1RPL	0000 0000	0000 0000	0000 0000	0000 0000	uuuu uuuu
PTM1RPH	---- --00	---- --00	---- --00	---- --00	---- --uu
PB	--11 1111	--11 1111	--11 1111	--11 1111	--uu uuuu
PBC	--11 1111	--11 1111	--11 1111	--11 1111	--uu uuuu
PBPU	--00 0000	--00 0000	--00 0000	--00 0000	--uu uuuu
EEC	---- 0000	---- 0000	---- 0000	---- 0000	---- uuuu

Note: “-” not implement
 “u” stands for “unchanged”
 “x” stands for “unknown”

Input/Output Ports

Holtek microcontrollers offer considerable flexibility on their I/O ports. With the input or output designation of every pin fully under user program control, pull-high selections for all ports and wake-up selections on certain pins, the user is provided with an I/O structure to meet the needs of a wide range of application possibilities.

The device provide bidirectional input/output lines labeled with port names PA~PB. These I/O ports are mapped to the RAM Data Memory with specific addresses as shown in the Special Purpose Data Memory table. All of these I/O ports can be used for input and output operations. For input operation, these ports are non-latching, which means the inputs must be ready at the T2 rising edge of instruction “MOV A, [m]”, where m denotes the port address. For output operation, all the data is latched and remains unchanged until the output latch is rewritten.

Register Name	Bit							
	7	6	5	4	3	2	1	0
PA	PA7	PA6	PA5	D4	D3	PA2	PA1	PA0
PAC	PAC7	PAC6	PAC5	D4	D3	PAC2	PAC1	PAC0
PAPU	PAPU7	PAPU6	PAPU5	D4	D3	PAPU2	PAPU1	PAPU0
PAWU	PAWU7	PAWU6	PAWU5	D4	D3	PAWU2	PAWU1	PAWU0
PB	—	—	PB5	D4	PB3	PB2	PB1	PB0
PBC	—	—	PBC5	D4	PBC3	PBC2	PBC1	PBC0
PBPU	—	—	PBPU5	D4	PBPU3	PBPU2	PBPU1	PBPU0
PASR	PAS7	PAS6	D5	D4	PAS3	PAS2	PAS1	PAS0
PBSR	—	—	PBS5	D4	PBS3	PBS2	PBS1	PBS0
IFS0	PTCK1PS1	PTCK1PS0	STCK0PS	STP0IPS	PTP1IPS	—	INTPS1	INTPS0

I/O Logic Function Register List

Pull-high Resistors

Many product applications require pull-high resistors for their switch inputs usually requiring the use of an external resistor. To eliminate the need for these external resistors, all I/O pins, when configured as an input have the capability of being connected to an internal pull-high resistor. These pull-high resistors are selected using register PAPU~PBPU, and are implemented using weak PMOS transistors.

• P_xPU Register

Bit	7	6	5	4	3	2	1	0
Name	PxPU7	PxPU6	PxPU5	PxPU4	PxPU3	PxPU2	PxPU1	PxPU0
R/W	R/W	R/W	R/W	R/W	R/W	R/W	R/W	R/W
POR	0	0	0	0	0	0	0	0

Bit 7~0 **P_xPU_n**: I/O Port x Pin pull-high function control
 0: Disable
 1: Enable

The P_xPU_n bit is used to control the pin pull-high function. Here the “x” can be A and B depending upon the selected device. However, the actual available bits for each I/O Port may be different. Note that the control bit PBPU3 and PBPU2 in the PBPU register should be fixed at “0” after power on.

Port A Wake-up

The HALT instruction forces the microcontroller into the SLEEP or IDLE Mode which preserves power, a feature that is important for battery and other low-power applications. Various methods exist to wake-up the microcontroller, one of which is to change the logic condition on one of the Port A pins from high to low. This function is especially suitable for applications that can be woken up via external switches. Each pin on Port A can be selected individually to have this wake-up feature using the PAWU register.

Note that the wake-up function can be controlled by the wake-up control registers only when the pin is selected as a general purpose input and the MCU enters the IDLE or SLEEP mode.

• PAWU Register

Bit	7	6	5	4	3	2	1	0
Name	PAWU7	PAWU6	PAWU5	D4	D3	PAWU2	PAWU1	PAWU0
R/W	R/W	R/W	R/W	R/W	R/W	R/W	R/W	R/W
POR	0	0	0	0	0	0	0	0

Bit 7~0 **I/O Port A bit 7 ~ bit 0 Wake Up Control**
 0: Disable
 1: Enable

I/O Port Control Registers

Each I/O port has its own control register known as PAC~PBC, to control the input/output configuration. With these control registers, each CMOS output or input can be reconfigured dynamically under software control. Each pin of the I/O ports is directly mapped to a bit in its associated port control register. For the I/O pin to function as an input, the corresponding bit of the control register must be written as a “1”. This will then allow the logic state of the input pin to be directly read by instructions. When the corresponding bit of the control register is written as a “0”, the I/O pin will be setup as a CMOS output. If the pin is currently setup as an output, instructions can still be used to read the output register. However, it should be noted that the program will in fact only read the status of the output data latch and not the actual logic status of the output pin.

• PxC Register

Bit	7	6	5	4	3	2	1	0
Name	PxC7	PxC6	PxC5	PxC4	PxC3	PxC2	PxC1	PxC0
R/W	R/W	R/W	R/W	R/W	R/W	R/W	R/W	R/W
POR	1	1	1	1	1	1	1	1

Bit 7~0 **PxCn**: I/O Port x Pin type selection
0: Output
1: Input

The PxCn bit is used to control the pin type selection. Here the “x” can be A and B. However, the actual available bits for each I/O Port may be different.

It is important to note that the PBC2 and PBC3 bit in the PBC register should properly configured to implement correct interconnection after power-on. This will ensure correct internal connection between the MCU and RF transmitter. In addition, the port control bit denoted as “Dn” for ports A and B should be cleared to “0” to set the corresponding pin as an output after power-on reset. This can prevent the device from consuming power due to input floating states for any unbonded pins.

Pin-shared Functions

The flexibility of the microcontroller range is greatly enhanced by the use of pins that have more than one function. Limited numbers of pins can force serious design constraints on designers but by supplying pins with multi-functions, many of these difficulties can be overcome. The way in which the pin function of each pin is selected is different for each function and a priority order is established where more than one pin function is selected simultaneously. Additionally there is a PASR and a PBSR register to establish certain pin functions. Generally speaking, the analog function has higher priority than the digital function. However, if more than two analog functions are enabled and the analog signal input comes from the same external pin, the analog input will be internally connected to all of these active analog functional modules.

Pin-shared Registers

The limited number of supplied pins in a package can impose restrictions on the amount of functions a certain device can contain. However by allowing the same pins to share several different functions and providing a means of function selection, a wide range of different functions can be incorporated into even relatively small package sizes.

• PASR Register

Bit	7	6	5	4	3	2	1	0
Name	PAS7	PAS6	D5	D4	PAS3	PAS2	PAS1	PAS0
R/W	R/W	R/W	R/W	R/W	R/W	R/W	R/W	R/W
POR	0	0	0	0	0	0	0	0

Bit 7 **PAS7**: PA7 Pin-Shared Control Bit
0: PA7/PTCK1
1: STP0B

Note: PAS7 is valid when RSTC=55H

Bit 6 **PAS6**: PA6 Pin-Shared Control Bit
0: PA6/PTCK1/STP0I
1: STP0

Bit 5~4 **D5~D4**: These bits should be fixed at “00” after power on and can not be changed

Bit 3 **PAS3**: PA2 Pin-Shared Control Bit
0: PA2/INT/STCK0
1: AN2

- Bit 2~1 **PAS2~PAS1:** PA1 Pin-Shared Control Bits
 0X: PA1
 10: VREF
 11: AN1
- Bit 0 **PAS0:** PA0 Pin-Shared Control Bit
 0: PA0/STP0I
 1: AN0

• **PBSR Register**

Bit	7	6	5	4	3	2	1	0
Name	—	—	PBS5	D4	PBS3	PBS2	PBS1	PBS0
R/W	—	—	R/W	R/W	R/W	R/W	R/W	R/W
POR	—	—	0	0	0	0	0	0

- Bit 7~6 Unimplemented, read as “0”
- Bit 5 **PBS5:** PB5 Pin-Shared Control Bit
 0: PB5
 1: PTP1
- Bit 4 **D4:** This bit must be fixed at “0” and can not be changed
- Bit 3 **PBS3:** PB3 Pin-Shared Control Bit
 0: PB3
 1: Reserved
- Bit 2 **PBS2:** PB2 Pin-Shared Control Bit
 0: PB2
 1: Reserved
- Bit 1 **PBS1:** PB1 Pin-Shared Control Bit
 0: PB1/PTCK1
 1: STP0B
- Bit 0 **PBS0:** PB0 Pin-Shared Control Bit
 0: PB0/PTP1I
 1: VREFO

• **IFS0 Register**

Bit	7	6	5	4	3	2	1	0
Name	PTCK1PS1	PTCK1PS0	STCK0PS	STP0IPS	PTP1IPS	—	INTPS1	INTPS0
R/W	R/W	R/W	R/W	R/W	R/W	—	R/W	R/W
POR	0	0	0	0	0	—	0	0

- Bit 7~6 **PTCK1PS1~PTCK1PS0:** PTCK1 input source pin selection
 00: Reserved
 01: PTCK1 on PA6
 10: PTCK1 on PA7
 11: PTCK1 on PB1
- Bit 5 **STCK0PS:** STCK0 input source pin selection
 0: Reserved
 1: STCK0 on PA2
- Bit 4 **STP0IPS:** STP0I input source pin selection
 0: STP0I on PA6
 1: STP0I on PA0
- Bit 3 **PTP1IPS:** PTP1I input source pin selection
 0: PTP1I on PA5
 1: PTP1I on PB0
- Bit 2 Unimplemented, read as “0”

Bit 1~0 **INTPS1~INTPS0:** $\overline{\text{INT}}$ input source selection
 00: Reserved
 01: $\overline{\text{INT}}$ on PA2
 10: Reserved
 11: Reserved

I/O Pin Structures

The accompanying diagrams illustrate the internal structures of some generic I/O pin types. As the exact logical construction of the I/O pin will differ from these drawings, they are supplied as a guide only to assist with the functional understanding of the I/O pins. The wide range of pin-shared structures does not permit all types to be shown.

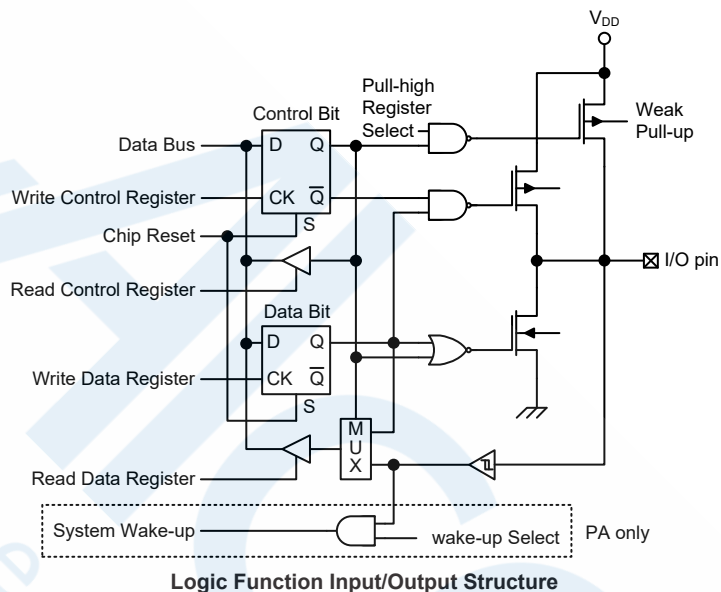

Programming Considerations

Within the user program, one of the first things to consider is port initialisation. After a reset, all of the I/O data and port control registers will be set high. This means that all I/O pins will default to an input state, the level of which depends on the other connected circuitry and whether pull-high selections have been chosen. If the port control registers are then programmed to setup some pins as outputs, these output pins will have an initial high output value unless the associated port data registers are first programmed. Selecting which pins are inputs and which are outputs can be achieved byte-wide by loading the correct values into the appropriate port control register or by programming individual bits in the port control register using the “SET [m].i” and “CLR [m].i” instructions. Note that when using these bit control instructions, a read-modify-write operation takes place. The microcontroller must first read in the data on the entire port, modify it to the required new bit values and then rewrite this data back to the output ports.

Port A has the additional capability of providing wake-up functions. When the device is in the SLEEP or IDLE Mode, various methods are available to wake the device up. One of these is a high to low transition of any of the Port A pins. Single or multiple pins on Port A can be setup to have this function.

Timer Modules – TM

One of the most fundamental functions in any microcontroller device is the ability to control and measure time. To implement time related functions the device includes several Timer Modules, abbreviated to the name TM. The TMs are multi-purpose timing units and serve to provide operations such as Timer/Counter, Input Capture, Compare Match Output and Single Pulse Output as well as being the functional unit for the generation of PWM signals. Each of the TMs has two individual interrupts. The addition of input and output pins for each TM ensures that users are provided with timing units with a wide and flexible range of features.

The common features of the different TM types are described here with more detailed information provided in the individual Standard and Periodic TM sections.

Introduction

The device contains several TMs depending upon which device is selected with each TM having a reference name of TM0~TM1. Each individual TM can be categorised as a certain type, namely Standard Type TM or Periodic Type TM. Although similar in nature, the different TM types vary in their feature complexity. The common features to the Standard and Periodic TMs will be described in this section and the detailed operation will be described in corresponding sections. The main features and differences between the two types of TMs are summarised in the accompanying table.

Function	STM	PTM
Timer/Counter	√	√
Input Capture	√	√
Compare Match Output	√	√
PWM Output	√	√
Single Pulse Output	√	√
PWM Alignment	Edge	Edge
PWM Adjustment Period & Duty	Duty or Period	Duty or Period

TM Function Summary

TM Operation

The two different types of TMs offer a diverse range of functions, from simple timing operations to PWM signal generation. The key to understanding how the TM operates is to see it in terms of a free running counter whose value is then compared with the value of pre-programmed internal comparators. When the free running counter has the same value as the pre-programmed comparator, known as a compare match situation, a TM interrupt signal will be generated which can clear the counter and perhaps also change the condition of the TM output pin. The internal TM counter is driven by a user selectable clock source, which can be an internal clock or an external pin.

TM Clock Source

The clock source which drives the main counter in each TM can originate from various sources. The selection of the required clock source is implemented using the xTnCK2~xTnCK0 bits in the xTM control registers. The clock source can be a ratio of either the system clock f_{SYS} or the internal high clock f_H , the f_{TBC} clock source or the external xTCKn pin. The xTCKn pin clock source is used to allow an external signal to drive the TM as an external clock source or for event counting.

TM Interrupts

The Standard and Periodic type TMs each has two internal interrupts, the internal comparator A or comparator P, which generate a TM interrupt when a compare match condition occurs. When a TM interrupt is generated, it can be used to clear the counter and also to change the state of the TM output pin.

TM External Pins

Each of the TMs, irrespective of what type, has two TM input pins, with the label xTCKn and xTPnI. The TM input pin xTCKn, is essentially a clock source for the TM and is selected using the xTnCK2~xTnCK0 bits in the xTMnC0 register. This external TM input pin allows an external clock source to drive the internal TM. This external TM input pin is shared with other functions but will be connected to the internal TM if selected using the xTnCK2~xTnCK0 bits. The TM input pin can be chosen to have either a rising or falling active edge.

The other TM input pin, xTPnI, is the capture input whose active edge can be a rising edge, a falling edge or both rising and falling edges and the active edge transition type is selected using the xTnIO1 and xTnIO0 bits in the xTMnC1 register.

The TMs each have one output pin with the label xTPn while some TMs have an additional output pin with the label xTPnB. When the TM is in the Compare Match Output Mode, these pins can be controlled by the TM to switch to a high or low level or to toggle when a compare match situation occurs. The external xTPn output pin is also the pin where the TM generates the PWM output waveform. As the TM output pins are pin-shared with other function, the TM output function must first be setup using registers. A single bit in one of the registers determines if its associated pin is to be used as an external TM output pin or if it is to have another function. The details are provided in the accompanying table.

STM	PTM
STCK0, STP0I STP0, STP0B	PTCK1, PTP1I PTP1

TM Input/Output Pins

TM Input/Output Pin Control Register

Selecting to have a TM input/output or whether to retain its other shared function is implemented using one register, with a single bit in each register corresponding to a TM input/output pin. Configuring the selection bits correctly will setup the corresponding pin as a TM input/output. The details of the pin-shared function selection are described in the pin-shared function section.

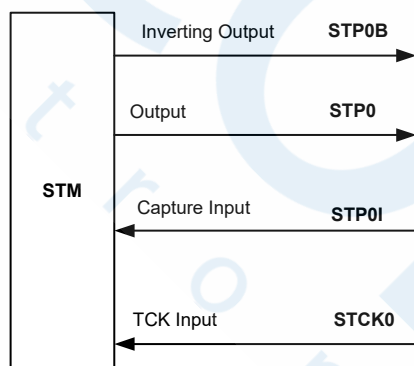

STM Function Pin Control Block Diagram

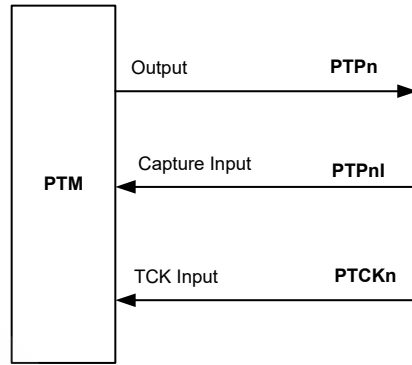

PTM Function Pin Control Block Diagram

Programming Considerations

The TM Counter Registers and the Capture/Compare CCRA register, and CCRP register pair for Periodic Timer Module, all have a low and high byte structure. The high bytes can be directly accessed, but as the low bytes can only be accessed via an internal 8-bit buffer, reading or writing to these register pairs must be carried out in a specific way. The important point to note is that data transfer to and from the 8-bit buffer and its related low byte only takes place when a write or read operation to its corresponding high byte is executed.

As the CCRA register and CCRP registers are implemented in the way shown in the following diagram and accessing the register is carried out CCRP low byte register using the following access procedures. Accessing the CCRA or CCRP low byte register without following these access procedures will result in unpredictable values.

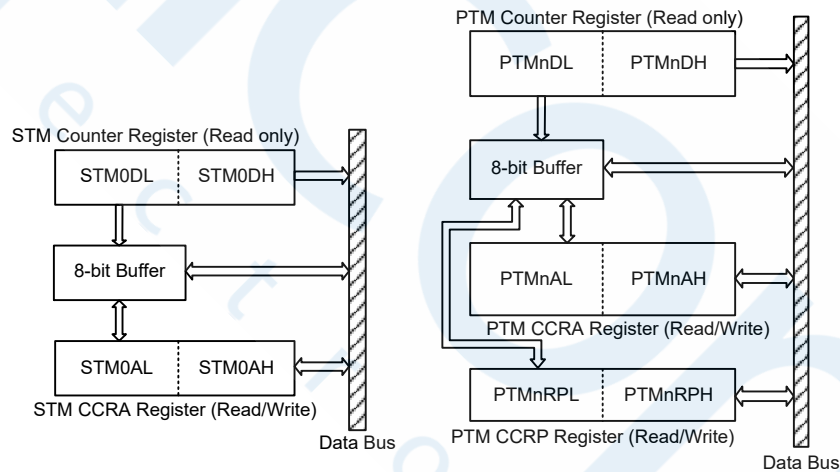

The following steps show the read and write procedures:

- Writing Data to CCRA or PTM CCRP
 - ♦ Step 1. Write data to Low Byte STM0AL, PTMnAL or PTMnRPL
 - note that here data is only written to the 8-bit buffer.
 - ♦ Step 2. Write data to High Byte STM0AH, PTMnAH or PTMnRPH
 - here data is written directly to the high byte registers and simultaneously data is latched from the 8-bit buffer to the Low Byte registers.

- Reading Data from the Counter Registers and CCRA or PTM CCRP
 - ♦ Step 1. Read data from the High Byte STM0DH, STM0AH, PTMnDH, PTMnAH or PTMnRPH – here data is read directly from the High Byte registers and simultaneously data is latched from the Low Byte register into the 8-bit buffer.
 - ♦ Step 2. Read data from the Low Byte STM0DL, STM0AL, PTMnDL, PTMnAL or PTMnRPL – this step reads data from the 8-bit buffer.

Standard Type TM – STM

The Standard Type TM contains five operating modes, which are Compare Match Output, Timer/Event Counter, Capture Input, Single Pulse Output and PWM Output modes. The Standard TM can be controlled with two external input pins and can drive two external output pins.

TM Type	TM Input Pin	TM Output Pin
10-bit STM	STCK0, STP0I	STP0, STP0B

Standard TM Operation

At its core is a 10-bit count-up counter which is driven by a user selectable internal clock source. There are also two internal comparators with the names, Comparator A and Comparator P. These comparators will compare the value in the counter with CCRP and CCRA registers. The CCRP is 3-bit wide whose value is compared with the highest 3 bits in the counter while the CCRA is the 10 bits and therefore compares with all counter bits.

The only way of changing the value of the 10-bit counter using the application program, is to clear the counter by changing the ST0ON bit from low to high. The counter will also be cleared automatically by a counter overflow or a compare match with one of its associated comparators. When these conditions occur, a TM interrupt signal will also usually be generated. The Standard Type TM can operate in a number of different operational modes, can be driven by different clock sources and can also control an output pin. All operating setup conditions are selected using relevant internal registers.

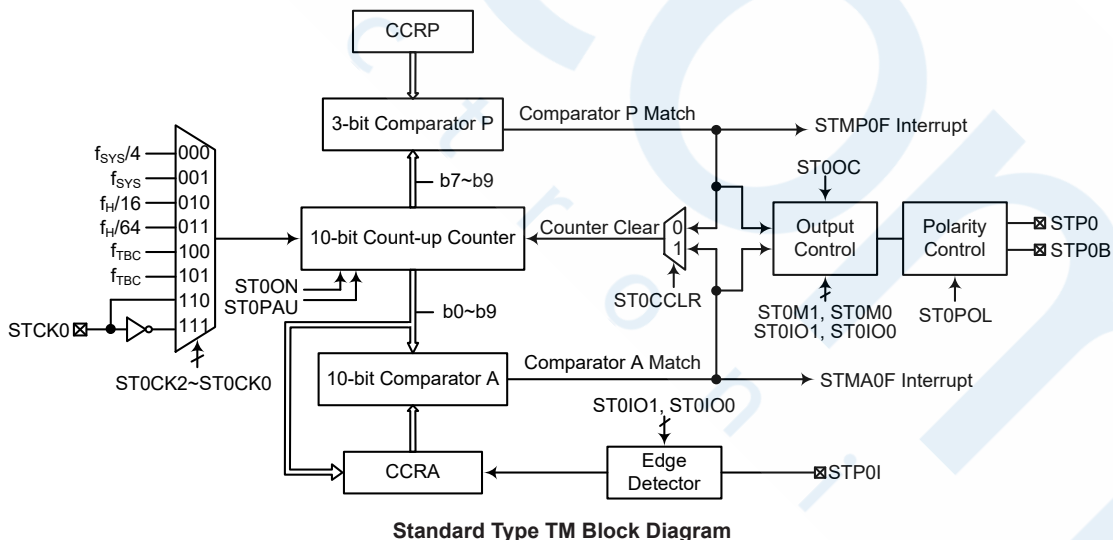

Standard Type TM Register Description

Overall operation of the Standard TM is controlled using a series of registers. A read only register pair exists to store the internal counter 10-bit value, while a read/write register pair exists to store the internal 10-bit CCRA value. The remaining two registers are control registers which setup the different operating and control modes as well as three CCRP bits.

Register Name	Bit							
	7	6	5	4	3	2	1	0
STM0C0	ST0PAU	ST0CK2	ST0CK1	ST0CK0	ST0ON	ST0RP2	ST0RP1	ST0RP0
STM0C1	ST0M1	ST0M0	ST0IO1	ST0IO0	ST0OC	ST0POL	ST0DPX	ST0CCLR
STM0DL	D7	D6	D5	D4	D3	D2	D1	D0
STM0DH	—	—	—	—	—	—	D9	D8
STM0AL	D7	D6	D5	D4	D3	D2	D1	D0
STM0AH	—	—	—	—	—	—	D9	D8

10-bit Standard TM Register List

• STM0C0 Register

Bit	7	6	5	4	3	2	1	0
Name	ST0PAU	ST0CK2	ST0CK1	ST0CK0	ST0ON	ST0RP2	ST0RP1	ST0RP0
R/W	R/W	R/W	R/W	R/W	R/W	R/W	R/W	R/W
POR	0	0	0	0	0	0	0	0

Bit 7 **ST0PAU:** STM Counter Pause Control
 0: Run
 1: Pause

The counter can be paused by setting this bit high. Clearing the bit to zero restores normal counter operation. When in a Pause condition the STM will remain powered up and continue to consume power. The counter will retain its residual value when this bit changes from low to high and resume counting from this value when the bit changes to a low value again.

Bit 6~4 **ST0CK2~ST0CK0:** Select STM Counter clock
 000: $f_{SYS}/4$
 001: f_{SYS}
 010: $f_{i}/16$
 011: $f_{i}/64$
 100: f_{TBC}
 101: f_{TBC}
 110: STCK0 rising edge clock
 111: STCK0 falling edge clock

These three bits are used to select the clock source for the STM. The external pin clock source can be chosen to be active on the rising or falling edge. The clock source f_{SYS} is the system clock, while f_{i} and f_{TBC} are other internal clocks, the details of which can be found in the oscillator section.

Bit 3 **ST0ON:** STM Counter On/Off Control
 0: Off
 1: On

This bit controls the overall on/off function of the STM. Setting the bit high enables the counter to run, clearing the bit disables the STM. Clearing this bit to zero will stop the counter from counting and turn off the STM which will reduce its power consumption. When the bit changes state from low to high the internal counter value will be reset to zero, however when the bit changes from high to low, the internal counter will retain its residual value until the bit returns high again. If the STM is in the Compare Match Output Mode or the PWM output Mode or Single Pulse Output

Mode then the STM output pin will be reset to its initial condition, as specified by the ST0OC bit, when the ST0ON bit changes from low to high.

Bit 2~0 **ST0RP2~ST0RP0**: STM CCRP 3-bit register, compared with the STM Counter bit 9 ~ bit 7

Comparator P Match Period

- 000: 1024 STM0 clocks
- 001: 128 STM0 clocks
- 010: 256 STM0 clocks
- 011: 384 STM0 clocks
- 100: 512 STM0 clocks
- 101: 640 STM0 clocks
- 110: 768 STM0 clocks
- 111: 896 STM0 clocks

These three bits are used to setup the value on the internal CCRP 3-bit register, which are then compared with the internal counter's highest three bits. The result of this comparison can be selected to clear the internal counter if the ST0CCLR bit is set to zero. Setting the ST0CCLR bit to zero ensures that a compare match with the CCRP values will reset the internal counter. As the CCRP bits are only compared with the highest three counter bits, the compare values exist in 128 clock cycle multiples. Clearing all three bits to zero is in effect allowing the counter to overflow at its maximum value.

• **STM0C1 Register**

Bit	7	6	5	4	3	2	1	0
Name	ST0M1	ST0M0	ST0IO1	ST0IO0	ST0OC	ST0POL	ST0DPX	ST0CCLR
R/W	R/W	R/W	R/W	R/W	R/W	R/W	R/W	R/W
POR	0	0	0	0	0	0	0	0

Bit 7~6 **ST0M1~ST0M0**: Select STM0 Operating Mode
 00: Compare Match Output Mode
 01: Capture Input Mode
 10: PWM output Mode or Single Pulse Output Mode
 11: Timer/Counter Mode

These bits setup the required operating mode for the STM. To ensure reliable operation the STM should be switched off before any changes are made to the ST0M1 and ST0M0 bits. In the Timer/Counter Mode, the STM output pin state is undefined.

Bit 5~4 **ST0IO1~ST0IO0**: Select STM0 external pin function

- Compare Match Output Mode
- 00: No change
 - 01: Output low
 - 10: Output high
 - 11: Toggle output
- PWM output Mode/ Single Pulse Output Mode
- 00: PWM Output inactive state
 - 01: PWM Output active state
 - 10: PWM output
 - 11: Single pulse output
- Capture Input Mode
- 00: Input capture at rising edge of STP0I
 - 01: Input capture at falling edge of STP0I
 - 10: Input capture at falling/rising edge of STP0I
 - 11: Input capture disabled
- Timer/counter Mode:
 Unused

These two bits are used to determine how the TM output pin changes state when a certain condition is reached. The function that these bits select depends upon in which mode the TM is running.

In the Compare Match Output Mode, the ST0IO1~ST0IO0 bits determine how the TM output pin changes state when a compare match occurs from the Comparator A. The TM output pin can be setup to switch high, switch low or to toggle its present state when a compare match occurs from the Comparator A. When the ST0IO1~ST0IO0 bits are both zero, then no change will take place on the output. The initial value of the TM output pin should be setup using the ST0OC bit. Note that the output level requested by the ST0IO1~ST0IO0 bits must be different from the initial value setup using the ST0OC bit otherwise no change will occur on the TM output pin when a compare match occurs. After the TM output pin changes state it can be reset to its initial level by changing the level of the ST0ON bit from low to high.

In the PWM Mode, the ST0IO1 and ST0IO0 bits determine how the TM output pin changes state when a certain compare match condition occurs. The PWM output function is modified by changing these two bits. It is necessary to change the values of the ST0IO1 and ST0IO0 bits only after the TM has been switched off. Unpredictable PWM outputs will occur if the ST0IO1 and ST0IO0 bits are changed when the TM is running.

Bit 3 **ST0OC: STM0 Output control bit**

Compare Match Output Mode

0: Initial low

1: Initial high

PWM output Mode/ Single Pulse Output Mode

0: Active low

1: Active high

This is the output control bit for the STM output pin. Its operation depends upon whether STM is being used in the Compare Match Output Mode or in the PWM output Mode/ Single Pulse Output Mode. It has no effect if the STM is in the Timer/Counter Mode. In the Compare Match Output Mode it determines the logic level of the STM output pin before a compare match occurs. In the PWM output Mode it determines if the PWM signal is active high or active low. In the Single Pulse Output Mode it determines the logic level of the STM output pin when the ST0ON bit changes from low to high.

Bit 2 **ST0POL: STM0 Output polarity Control**

0: Non-invert

1: Invert

This bit controls the polarity of the STM0 output pin. When the bit is set high the STM output pin will be inverted and not inverted when the bit is zero. It has no effect if the STM is in the Timer/Counter Mode.

Bit 1 **ST0DPX: STM0 PWM period/duty Control**

0: CCRP – period; CCRA – duty

1: CCRP – duty; CCRA – period

This bit determines which of the CCRA and CCRP registers are used for period and duty control of the PWM waveform.

Bit 0 **ST0CCLR: Select STM0 Counter clear condition**

0: STM0 Comparator P match

1: STM0 Comparator A match

This bit is used to select the method which clears the counter. Remember that the Standard STM contains two comparators, Comparator A and Comparator P, either of which can be selected to clear the internal counter. With the ST0CCLR bit set high, the counter will be cleared when a compare match occurs from the Comparator A. When the bit is low, the counter will be cleared when a compare match occurs from the Comparator P or with a counter overflow. A counter overflow clearing method can only be implemented if the CCRP bits are all cleared to zero. The ST0CCLR bit is not used in the PWM output mode, Single Pulse or Input Capture Mode.

• **STM0DL Register**

Bit	7	6	5	4	3	2	1	0
Name	D7	D6	D5	D4	D3	D2	D1	D0
R/W	R	R	R	R	R	R	R	R
POR	0	0	0	0	0	0	0	0

Bit 7~0 STM0 Counter Low Byte Register bit 7 ~ bit 0
 STM0 10-bit Counter bit 7 ~ bit 0

• **STM0DH Register**

Bit	7	6	5	4	3	2	1	0
Name	—	—	—	—	—	—	D9	D8
R/W	—	—	—	—	—	—	R	R
POR	—	—	—	—	—	—	0	0

Bit 7~2 Unimplemented, read as “0”
 Bit 1~0 STM0 Counter High Byte Register bit 1 ~ bit 0
 STM0 10-bit Counter bit 9 ~ bit 8

• **STM0AL Register**

Bit	7	6	5	4	3	2	1	0
Name	D7	D6	D5	D4	D3	D2	D1	D0
R/W	R/W	R/W	R/W	R/W	R/W	R/W	R/W	R/W
POR	0	0	0	0	0	0	0	0

Bit 7~0 STM0 CCRA Low Byte Register bit 7 ~ bit 0
 STM0 10-bit CCRA bit 7 ~ bit 0

• **STM0AH Register**

Bit	7	6	5	4	3	2	1	0
Name	—	—	—	—	—	—	D9	D8
R/W	—	—	—	—	—	—	R/W	R/W
POR	—	—	—	—	—	—	0	0

Bit 7~2 Unimplemented, read as “0”
 Bit 1~0 STM0 CCRA High Byte Register bit 1 ~ bit 0
 STM0 10-bit CCRA bit 9 ~ bit 8

Standard Type TM Operating Modes

The Standard Type TM can operate in one of five operating modes, Compare Match Output Mode, PWM Output Mode, Single Pulse Output Mode, Capture Input Mode or Timer/Counter Mode. The operating mode is selected using the ST0M1 and ST0M0 bits in the STM0C1 register.

Compare Output Mode

To select this mode, bits ST0M1 and ST0M0 in the STM0C1 register, should be set to 00 respectively. In this mode once the counter is enabled and running it can be cleared by three methods. These are a counter overflow, a compare match from Comparator A and a compare match from Comparator P. When the ST0CCLR bit is low, there are two ways in which the counter can be cleared. One is when a compare match from Comparator P, the other is when the CCRP bits are all zero which allows the counter to overflow. Here both STMA0F and STMP0F interrupt request flags for Comparator A and Comparator P respectively, will both be generated.

If the ST0CCLR bit in the STM0C1 register is high then the counter will be cleared when a compare match occurs from Comparator A. However, here only the STMA0F interrupt request flag will be generated even if the value of the CCRP bits is less than that of the CCRA registers. Therefore when ST0CCLR is high no STMP0F interrupt request flag will be generated. In the Compare Match Output Mode, the CCRA can not be set to "0". If the CCRA bits are all zero, the counter will overflow when it reaches its maximum 10-bit, 3FF Hex, value, however here the STMA0F interrupt request flag will not be generated.

As the name of the mode suggests, after a comparison is made, the STM output pin, will change state. The STM output pin condition however only changes state when an STMA0F interrupt request flag is generated after a compare match occurs from Comparator A. The STMP0F interrupt request flag, generated from a compare match occurs from Comparator P, will have no effect on the STM output pin. The way in which the STM output pin changes state are determined by the condition of the ST0IO1 and ST0IO0 bits in the STM0C1 register. The STM output pin can be selected using the ST0IO1 and ST0IO0 bits to go high, to go low or to toggle from its present condition when a compare match occurs from Comparator A. The initial condition of the STM output pin, which is setup after the ST0ON bit changes from low to high, is setup using the ST0OC bit. Note that if the ST0IO1 and ST0IO0 bits are zero then no pin change will take place.

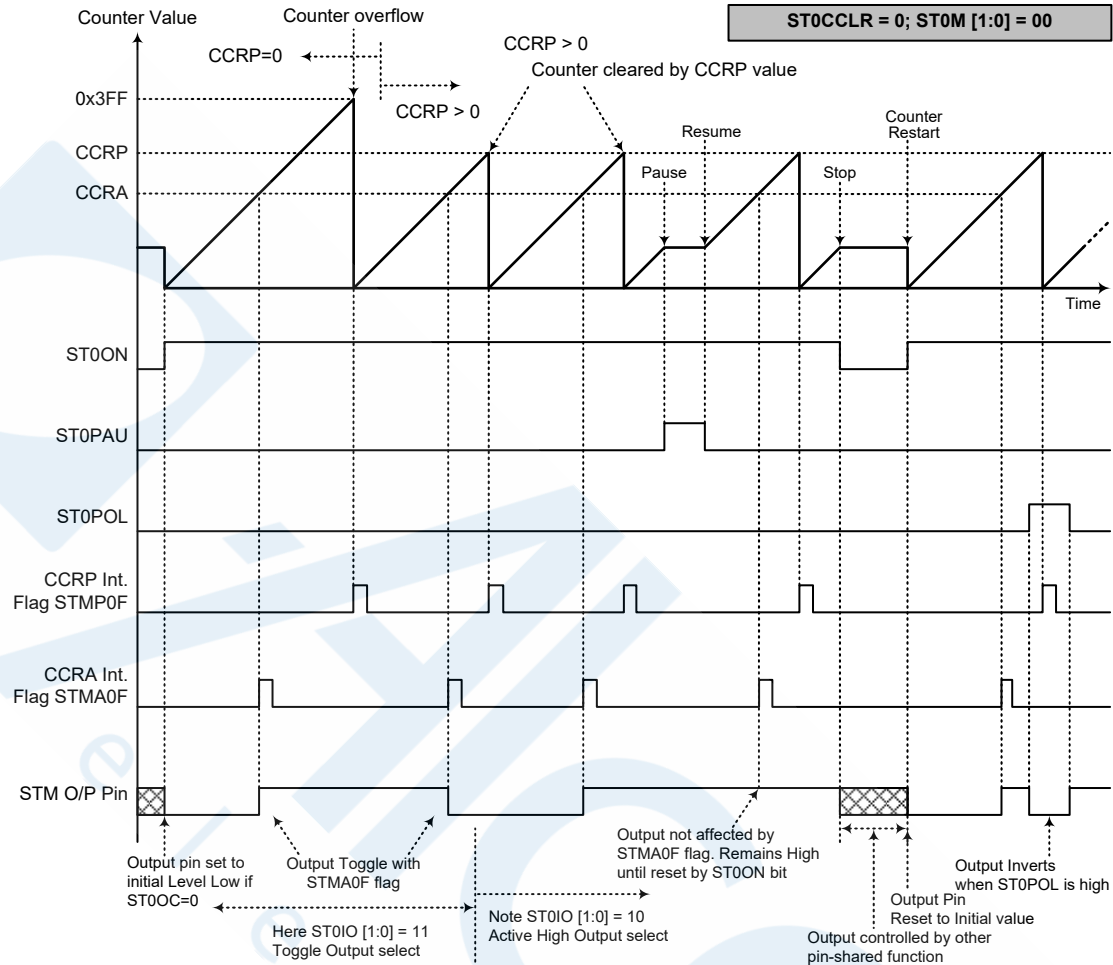

Compare Match Output Mode – ST0CCLR=0

- Note: 1. With ST0CCLR=0 a Comparator P match will clear the counter
2. The TM output pin controlled only by the STMA0F flag
3. The output pin reset to initial state by a ST0ON bit rising edge

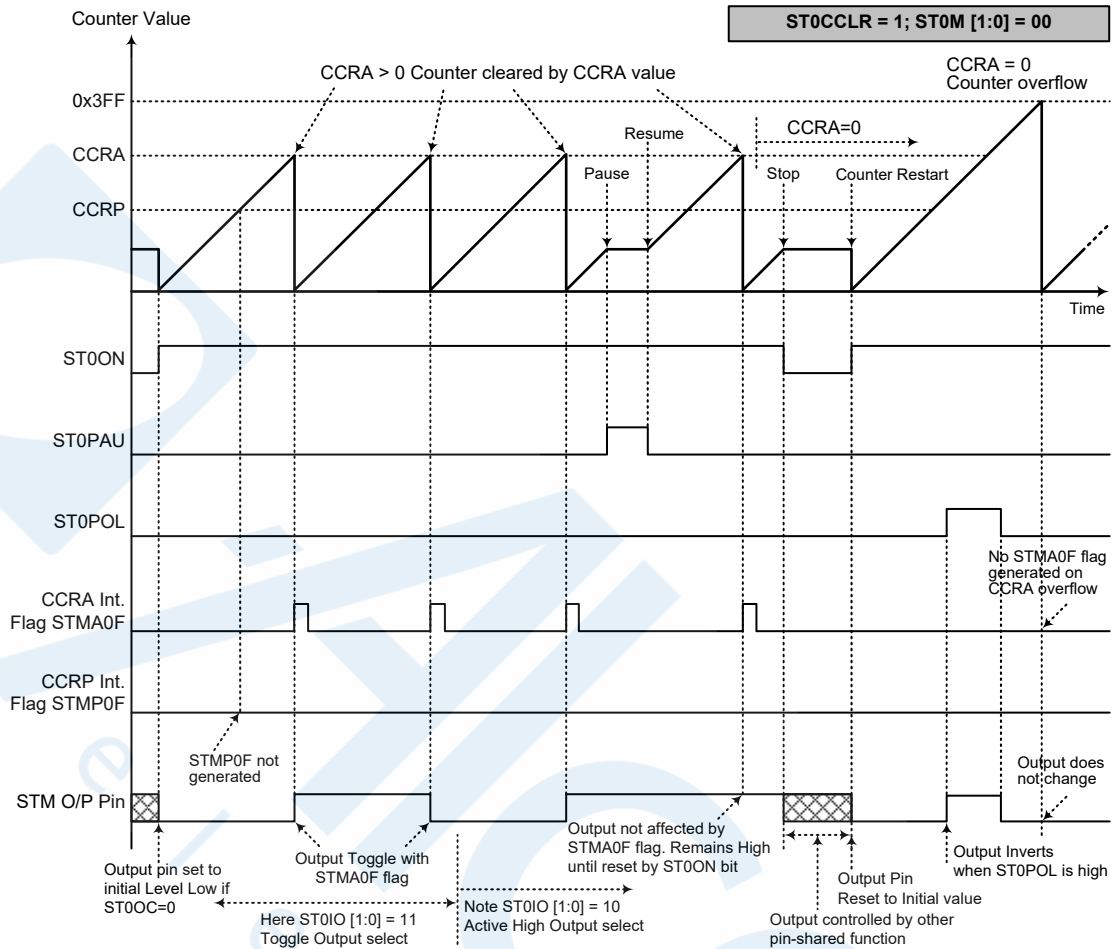

Compare Match Output Mode – ST0CCLR=1

- Note: 1. With ST0CCLR=1 a Comparator A match will clear the counter
2. The TM output pin controlled only by the STMA0F flag
3. The output pin reset to initial state by a ST0ON rising edge
4. The STMP0F flag is not generated when ST0CCLR=1

Timer/Counter Mode

To select this mode, bits ST0M1 and ST0M0 in the STM0C1 register should be set to 11 respectively. The Timer/Counter Mode operates in an identical way to the Compare Match Output Mode generating the same interrupt flags. The exception is that in the Timer/Counter Mode the STM output pin is not used. Therefore the above description and Timing Diagrams for the Compare Match Output Mode can be used to understand its function. As the STM output pin is not used in this mode, the pin can be used as a normal I/O pin or other pin-shared function by setting pin-share function register.

PWM Output Mode

To select this mode, bits ST0M1 and ST0M0 in the STM0C1 register should be set to 10 respectively and also the ST0IO1 and ST0IO0 bits should be set to 10 respectively. The PWM function within the STM is useful for applications which require functions such as motor control, heating control, illumination control etc. By providing a signal of fixed frequency but of varying duty cycle on the STM output pin, a square wave AC waveform can be generated with varying equivalent DC RMS values.

As both the period and duty cycle of the PWM waveform can be controlled, the choice of generated waveform is extremely flexible. In the PWM output mode, the ST0CCLR bit has no effect as the PWM period. Both of the CCRA and CCRP registers are used to generate the PWM waveform, one register is used to clear the internal counter and thus control the PWM waveform frequency, while the other one is used to control the duty cycle. Which register is used to control either frequency or duty cycle is determined using the ST0DPX bit in the STM0C1 register. The PWM waveform frequency and duty cycle can therefore be controlled by the values in the CCRA and CCRP registers.

An interrupt flag, one for each of the CCRA and CCRP, will be generated when a compare match occurs from either Comparator A or Comparator P. The ST0OC bit in the STM0C1 register is used to select the required polarity of the PWM waveform while the two ST0IO1 and ST0IO0 bits are used to enable the PWM output or to force the STM output pin to a fixed high or low level. The ST0POL bit is used to reverse the polarity of the PWM output waveform.

• **10-bit STM, PWM Output Mode, Edge-aligned Mode, ST0DPX=0**

CCRP	001b	010b	011b	100b	101b	110b	111b	000b
Period	128	256	384	512	640	768	896	1024
Duty	CCRA							

If $f_{SYS}=8\text{MHz}$, TM clock source is $f_{SYS}/4$, CCRP=100b and CCRA=28,

The STM PWM output frequency= $(f_{SYS}/4)/512=f_{SYS}/2048=3.9063\text{kHz}$, duty=128/512=25%.

If the Duty value defined by the CCRA register is equal to or greater than the Period value, then the PWM output duty is 100%.

• **10-bit STM, PWM Output Mode, Edge-aligned Mode, ST0DPX=1**

CCRP	001b	010b	011b	100b	101b	110b	111b	000b
Period	CCRA							
Duty	128	256	384	512	640	768	896	1024

The PWM output period is determined by the CCRA register value together with the STM clock while the PWM duty cycle is defined by the CCRP register value.

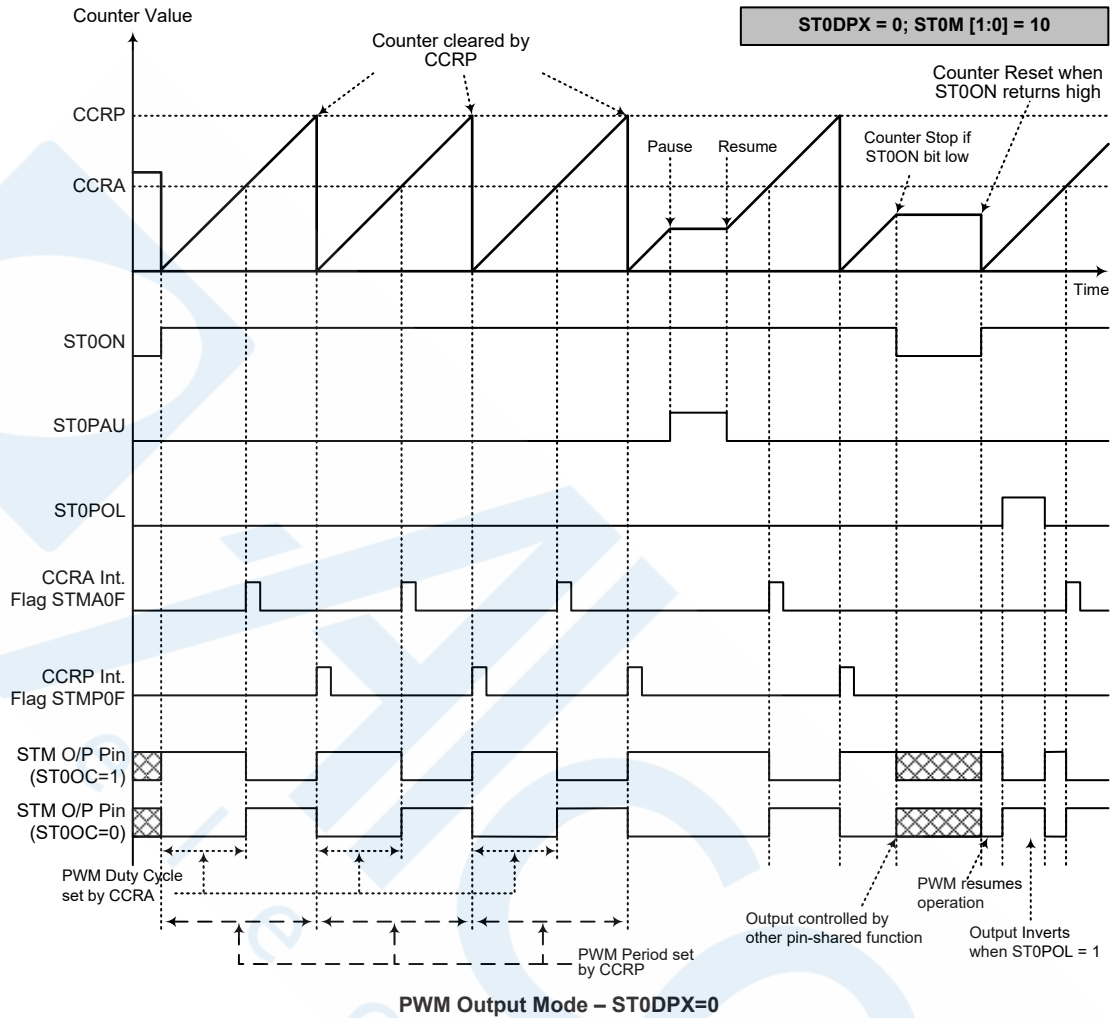

- Note: 1. Here ST0DPX=0 – Counter cleared by CCRP
 2. A counter clear sets PWM Period
 3. The internal PWM function continues running even when ST0IO[1:0]=00 or 01
 4. The ST0CCLR bit has no influence on PWM operation

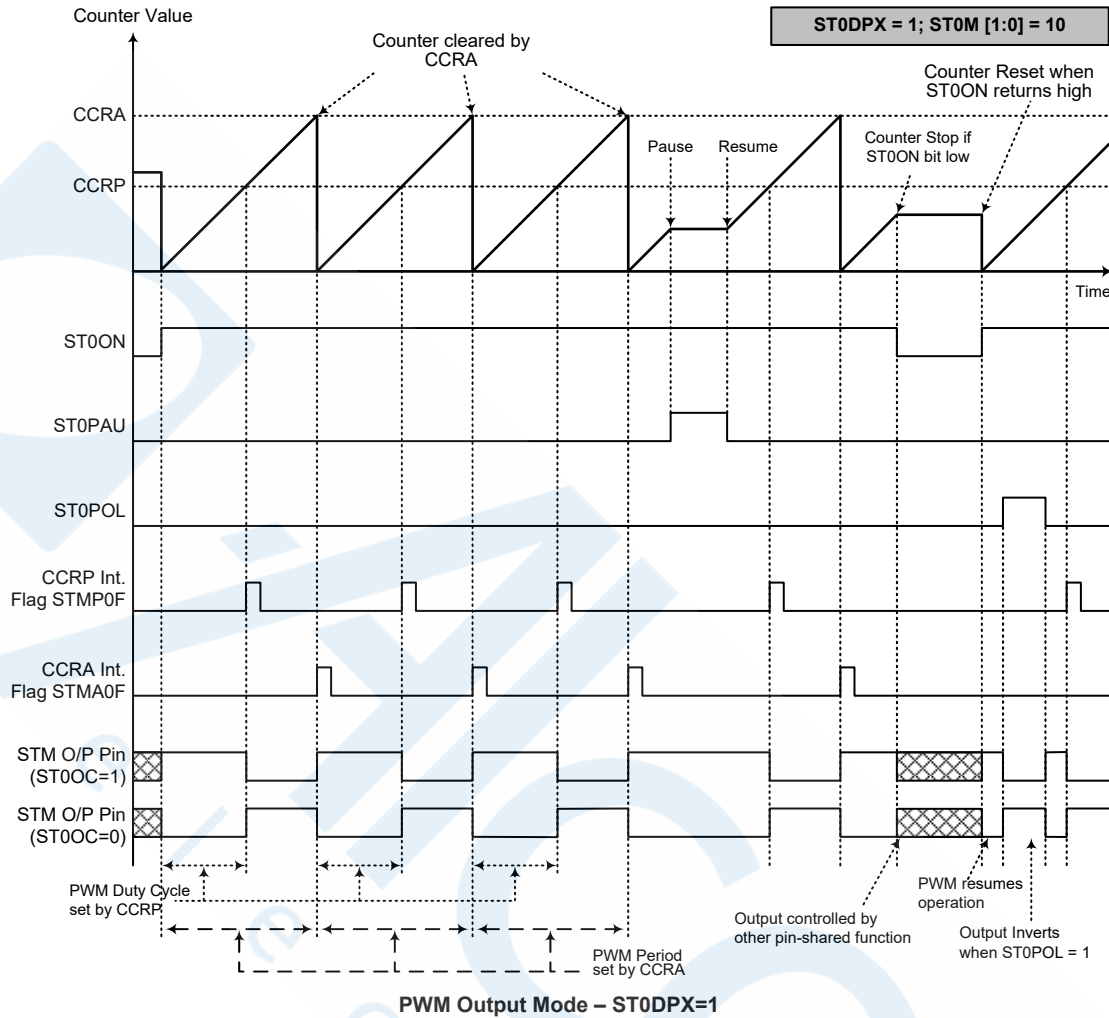

- Note: 1. Here ST0DPX=1 – Counter cleared by CCRA
 2. A counter clear sets PWM Period
 3. The internal PWM function continues even when ST0IO[1:0]=00 or 01
 4. The ST0CCLR bit has no influence on PWM operation

Single Pulse Mode

To select this mode, bits ST0M1 and ST0M0 in the STM0C1 register should be set to 10 respectively and also the ST0IO1 and ST0IO0 bits should be set to 11 respectively. The Single Pulse Output Mode, as the name suggests, will generate a single shot pulse on the STM output pin.

The trigger for the pulse output leading edge is a low to high transition of the ST0ON bit, which can be implemented using the application program. However in the Single Pulse Mode, the ST0ON bit can also be made to automatically change from low to high using the external STCK0 pin, which will in turn initiate the Single Pulse output. When the ST0ON bit transitions to a high level, the counter will start running and the pulse leading edge will be generated. The ST0ON bit should remain high when the pulse is in its active state. The generated pulse trailing edge will be generated when the ST0ON bit is cleared to zero, which can be implemented using the application program or when a compare match occurs from Comparator A.

However a compare match from Comparator A will also automatically clear the ST0ON bit and thus generate the Single Pulse output trailing edge. In this way the CCRA value can be used to control the pulse width. A compare match from Comparator A will also generate a STM interrupt. The counter can only be reset back to zero when the ST0ON bit changes from low to high when the counter restarts. In the Single Pulse Mode CCRP is not used. The ST0CCLR and ST0DPX bits are not used in this mode.

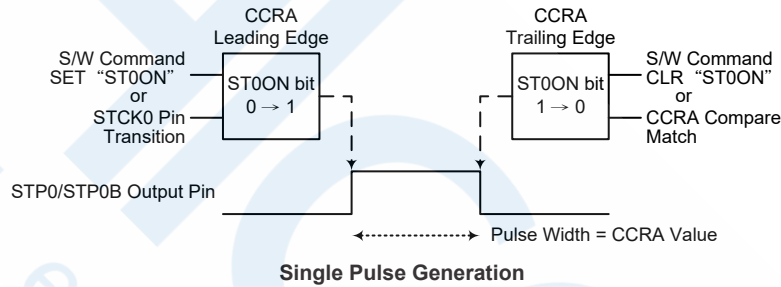

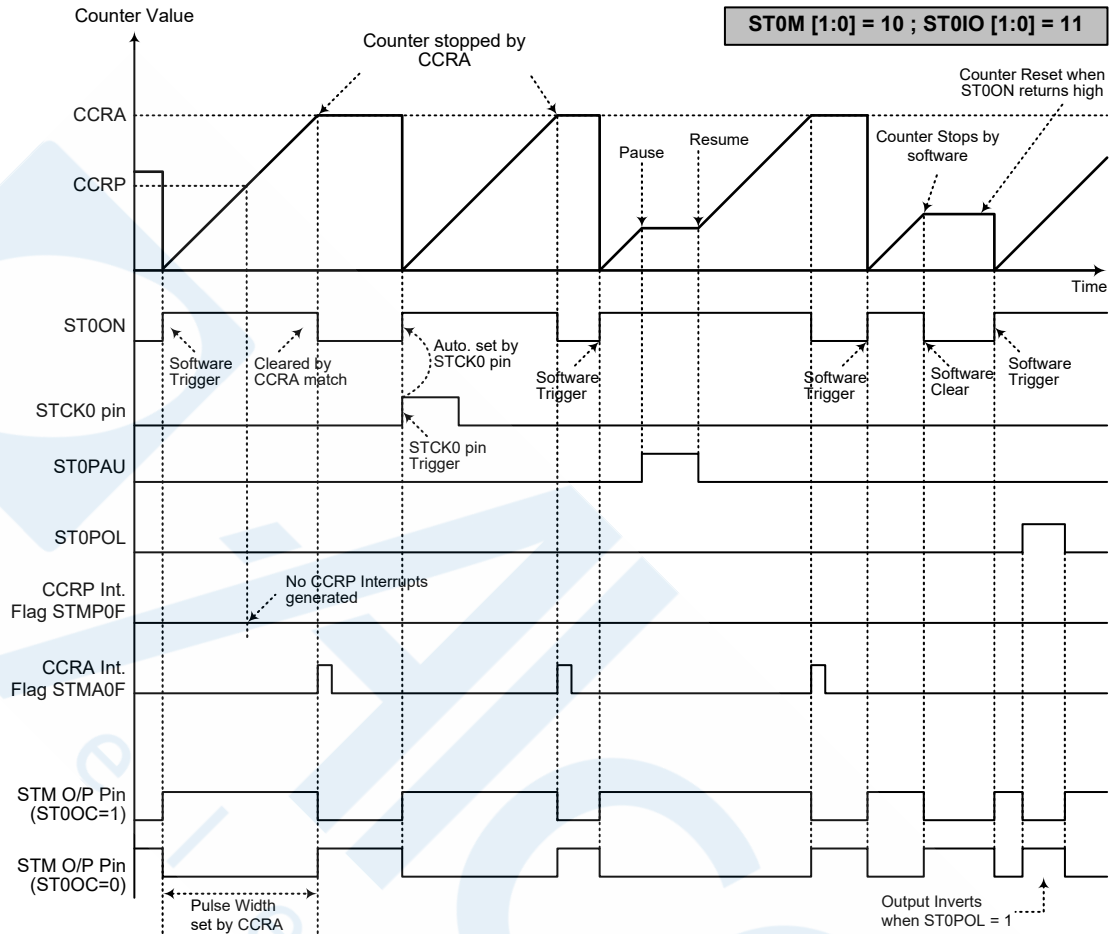

Single Pulse Output Mode

- Note:
1. Counter stopped by CCRA match
 2. CCRP is not used
 3. The pulse is triggered by setting the ST0ON bit high
 4. In the Single Pulse Mode, ST0IO[1:0] must be set to "11" and can not be changed

Capture Input Mode

To select this mode bits ST0M1 and ST0M0 in the STM0C1 register should be set to 01 respectively. This mode enables external signals to capture and store the present value of the internal counter and can therefore be used for applications such as pulse width measurements. The external signal is supplied on the STP0I, whose active edge can be either a rising edge, a falling edge or both rising and falling edges; the active edge transition type is selected using the ST0IO1 and ST0IO0 bits in the STM0C1 register. The counter is started when the ST0ON bit changes from low to high which is initiated using the application program.

When the required edge transition appears on the STP0I the present value in the counter will be latched into the CCRA registers and a STM interrupt generated. Irrespective of what events occur on the STP0I the counter will continue to free run until the ST0ON bit changes from high to low. When a CCRP compare match occurs the counter will reset back to zero; in this way the CCRP value can be used to control the maximum counter value. When a CCRP compare match occurs from Comparator P, a STM interrupt will also be generated. Counting the number of overflow interrupt signals from the CCRP can be a useful method in measuring long pulse widths. The ST0IO1 and ST0IO0 bits can select the active trigger edge on the STP0I to be a rising edge, falling edge or both edge types. If the ST0IO1 and ST0IO0 bits are both set high, then no capture operation will take place irrespective of what happens on the STP0I, however it must be noted that the counter will continue to run. The ST0CCLR and ST0DPX bits are not used in this mode.

There are some considerations that should be noted. If the captured pulse width is less than 2 timer clock periods, it may be ignored by hardware. After the counter value is latched to the CCRA registers by an active capture edge, the STMA0F flag will be set high after 0.5 timer clock period. The delay time from the active capture edge received to the action of latching counter value to CCRA registers is less than 1.5 timer clock periods.

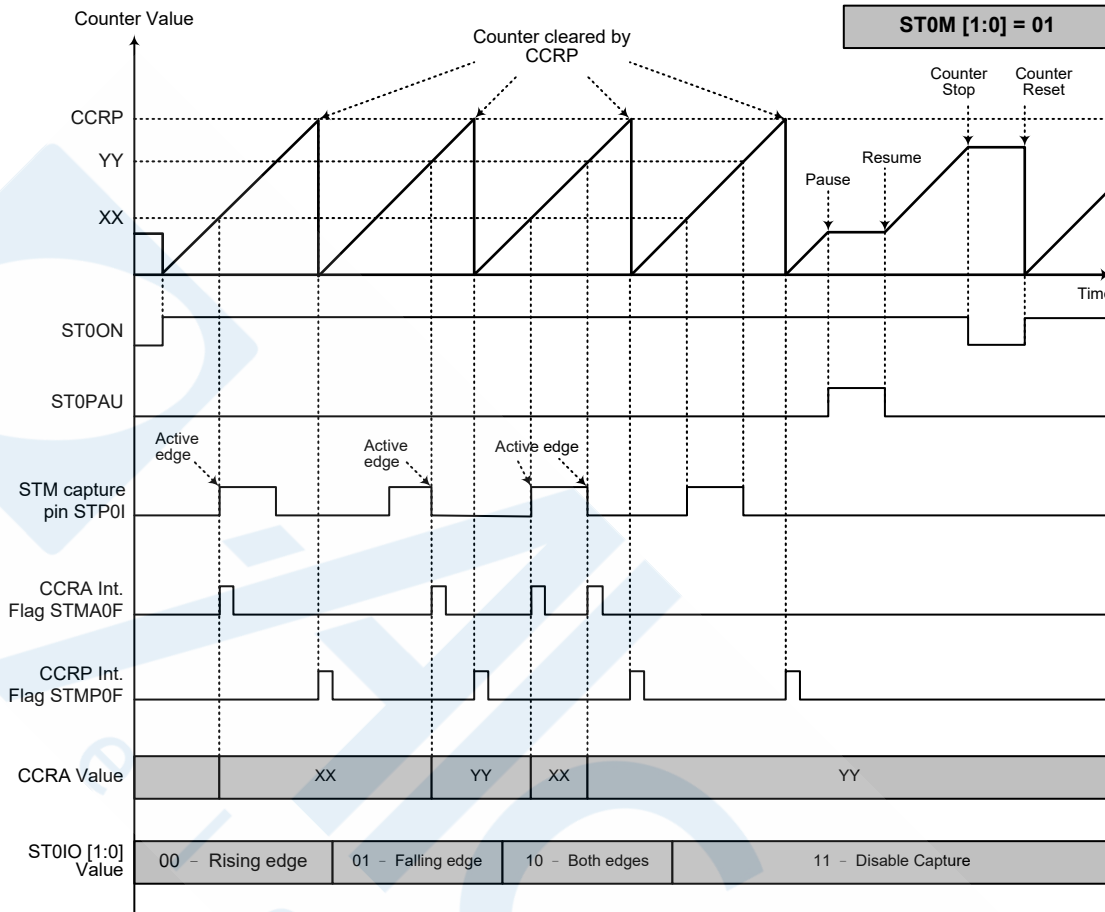

Capture Input Mode

- Note: 1. ST0M[1:0]=01 and active edge set by the ST0IO[1:0] bits
 2. A TM Capture input pin active edge transfers the counter value to CCRA
 3. The ST0CCLR and ST0DPX bits are not used
 4. No output function – ST0OC and ST0POL bits are not used
 5. CCRP determines the counter value and the counter has a maximum count value when CCRP is equal to zero

Periodic Type TM – PTM

The Periodic Type TM contains five operating modes, which are Compare Match Output, Timer/Event Counter, Capture Input, Single Pulse Output and PWM Output modes. The Periodic TM can also be controlled with two external input pins and can drive one external output pins.

Name	TM Input Pin	TM Output Pin
10-bit PTM	PTCK1, PTP1I	PTP1

Periodic TM Operation

At its core is a 10-bit count-up counter which is driven by a user selectable internal or external clock source. There are two internal comparators with the names, Comparator A and Comparator P. These comparators will compare the value in the counter with the CCRA and CCRP registers.

The only way of changing the value of the 10-bit counter using the application program, is to clear the counter by changing the PTnON bit from low to high. The counter will also be cleared automatically by a counter overflow or a compare match with one of its associated comparators. When these conditions occur, a TM interrupt signal will also usually be generated. The Periodic Type TM can operate in a number of different operational modes, can be driven by different clock sources including an input pin and can also control the output pin. All operating setup conditions are selected using relevant internal registers.

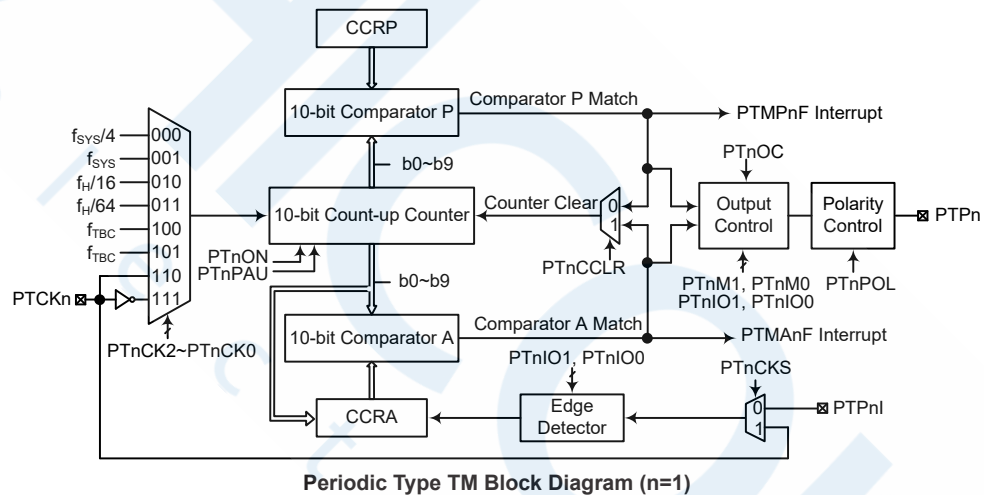

Periodic Type TM Register Description

Overall operation of the Periodic TM is controlled using a series of registers. A read only register pair exists to store the internal counter 10-bit value, while two read/write register pairs exist to store the internal 10-bit CCRA and CCRP value. The remaining two registers are control registers which setup the different operating and control modes.

Register Name	Bit							
	7	6	5	4	3	2	1	0
PTMnCO	PTnPAU	PTnCK2	PTnCKn	PTnCK0	PTnON	—	—	—
PTMnCn	PTnM1	PTnM0	PTnIO1	PTnIO0	PTnOC	PTnPOL	PTnCKS	PTnCCLR
PTMnDL	D7	D6	D5	D4	D3	D2	D1	D0
PTMnDH	—	—	—	—	—	—	D9	D8
PTMnAL	D7	D6	D5	D4	D3	D2	D1	D0
PTMnAH	—	—	—	—	—	—	D9	D8
PTMnRPL	D7	D6	D5	D4	D3	D2	D1	D0
PTMnRPH	—	—	—	—	—	—	D9	D8

10-bit Periodic TM Register List (n=1)

• PTMnCO Register

Bit	7	6	5	4	3	2	1	0
Name	PTnPAU	PTnCK2	PTnCK1	PTnCK0	PTnON	—	—	—
R/W	R/W	R/W	R/W	R/W	R/W	—	—	—
POR	0	0	0	0	0	—	—	—

Bit 7 **PTnPAU**: PTM Counter Pause Control
0: run
1: pause

The counter can be paused by setting this bit high. Clearing the bit to zero restores normal counter operation. When in a Pause condition the TM will remain powered up and continue to consume power. The counter will retain its residual value when this bit changes from low to high and resume counting from this value when the bit changes to a low value again.

Bit 6~4 **PTnCK2~PTnCK0**: Select PTM Counter clock
000: $f_{SYS}/4$
001: f_{SYS}
010: $f_H/16$
011: $f_H/64$
100: f_{TBC}
101: f_{TBC}
110: PTCKn rising edge clock
111: PTCKn falling edge clock

These three bits are used to select the clock source for the TM. The external pin clock source can be chosen to be active on the rising or falling edge. The clock source f_{SYS} is the system clock, while f_{TBC} is another internal clock, the details of which can be found in the oscillator section.

Bit 3 **PTnON**: PTM Counter On/Off Control
0: Off
1: On

This bit controls the overall on/off function of the TM. Setting the bit high enables the counter to run, clearing the bit disables the TM. Clearing this bit to zero will stop the counter from counting and turn off the TM which will reduce its power consumption. When the bit changes state from low to high the internal counter value will be reset to zero, however when the bit changes from high to low, the internal counter will retain its residual value until the bit returns high again.

If the TM is in the Compare Match Output Mode then the TM output pin will be reset to its initial condition, as specified by the TM Output control bit, when the bit changes from low to high.

Bit 2~0 Unimplemented, read as “0”

• **PTMnC1 Register**

Bit	7	6	5	4	3	2	1	0
Name	PTnM1	PTnM0	PTnIO1	PTnIO0	PTnOC	PTnPOL	PTnCKS	PTnCCLR
R/W	R/W	R/W	R/W	R/W	R/W	R/W	R/W	R/W
POR	0	0	0	0	0	0	0	0

Bit 7~6 **PTnM1~PTnM0**: Select PTM Operation Mode
 00: Compare Match Output Mode
 01: Capture Input Mode
 10: PWM Mode or Single Pulse Output Mode
 11: Timer/Counter Mode

These bits setup the required operating mode for the TM. To ensure reliable operation the TM should be switched off before any changes are made to the PTnM1 and PTnM0 bits. In the Timer/Counter Mode, the PTM output pin state is undefined.

Bit 5~4 **PTnIO1~PTnIO0**: Select PTM external pin function

Compare Match Output Mode
 00: No change
 01: Output low
 10: Output high
 11: Toggle output

PWM Mode/Single Pulse Output Mode
 00: PWM Output inactive state
 01: PWM Output active state
 10: PWM output
 11: Single pulse output

Capture Input Mode
 00: Input capture at rising edge of PTPnI or PTCKn
 01: Input capture at falling edge of PTPnI or PTCKn
 10: Input capture at falling/rising edge of PTPnI or PTCKn
 11: Input capture disabled

Timer/counter Mode
 Unused

These two bits are used to determine how the TM output pin changes state when a certain condition is reached. The function that these bits select depends upon in which mode the TM is running.

In the Compare Match Output Mode, the PTnIO1 and PTnIO0 bits determine how the TM output pin changes state when a compare match occurs from the Comparator A. The TM output pin can be setup to switch high, switch low or to toggle its present state when a compare match occurs from the Comparator A. When these bits are both zero, then no change will take place on the output. The initial value of the TM output pin should be setup using the PTnOC bit. Note that the output level requested by the PTnIO1 and PTnIO0 bits must be different from the initial value setup using the PTnOC bit otherwise no change will occur on the TM output pin when a compare match occurs. After the TM output pin changes state, it can be reset to its initial level by changing the level of the PTnON bit from low to high.

In the PWM Mode, the PTnIO1 and PTnIO0 bits determine how the TM output pin changes state when a certain compare match condition occurs. The PWM output function is modified by changing these two bits. It is necessary to change the values of the PTnIO1 and PTnIO0 bits only after the TM has been switched off. Unpredictable PWM outputs will occur if the PTnIO1 and PTnIO0 bits are changed when the TM is running.

Bit 3 **PTnOC**: PTPn Output control bit
 Compare Match Output Mode
 0: initial low
 1: initial high

PWM Mode/ Single Pulse Output Mode

- 0: Active low
- 1: Active high

This is the output control bit for the TM output pin. Its operation depends upon whether TM is being used in the Compare Match Output Mode or in the PWM Mode/Single Pulse Output Mode. It has no effect if the TM is in the Timer/Counter Mode. In the Compare Match Output Mode it determines the logic level of the TM output pin before a compare match occurs. In the PWM Mode it determines if the PWM signal is active high or active low.

Bit 2 **PTnPOL**: PTPn Output polarity Control

- 0: non-invert
- 1: invert

This bit controls the polarity of the PTPn output pin. When the bit is set high the TM output pin will be inverted and not inverted when the bit is zero. It has no effect if the TM is in the Timer/Counter Mode.

Bit 1 **PTnCKS**: PTM capture trigger source select

- 0: From PTPnI
- 1: From PTCKn pin

Bit 0 **PTnCCLR**: Select PTM Counter clear condition

- 0: PTM Comparatror P match
- 1: PTM Comparatror A match

This bit is used to select the method which clears the counter. Remember that the Periodic TM contains two comparators, Comparator A and Comparator P, either of which can be selected to clear the internal counter. With the PTnCCLR bit set high, the counter will be cleared when a compare match occurs from the Comparator A. When the bit is low, the counter will be cleared when a compare match occurs from the Comparator P or with a counter overflow. A counter overflow clearing method can only be implemented if the CCRP bits are all cleared to zero. The PTnCCLR bit is not used in the PWM, Single Pulse Output or Input Capture Mode.

• **PTMnDL Register**

Bit	7	6	5	4	3	2	1	0
Name	D7	D6	D5	D4	D3	D2	D1	D0
R/W	R	R	R	R	R	R	R	R
POR	0	0	0	0	0	0	0	0

Bit 7~0 PTM Counter Low Byte Register bit 7 ~ bit 0
 PTM 10-bit Counter bit 7 ~ bit 0

• **PTMnDH Register**

Bit	7	6	5	4	3	2	1	0
Name	—	—	—	—	—	—	D9	D8
R/W	—	—	—	—	—	—	R	R
POR	—	—	—	—	—	—	0	0

Bit 7~2 Unimplemented, read as “0”
 Bit 1~0 PTM Counter High Byte Register bit 1 ~ bit 0
 PTM 10-bit Counter bit 9 ~ bit 8

• **PTMnAL Register**

Bit	7	6	5	4	3	2	1	0
Name	D7	D6	D5	D4	D3	D2	D1	D0
R/W	R/W	R/W	R/W	R/W	R/W	R/W	R/W	R/W
POR	0	0	0	0	0	0	0	0

Bit 7~0 PTM CCRA Low Byte Register bit 7 ~ bit 0
PTM 10-bit CCRA bit 7 ~ bit 0

• **PTMnAH Register**

Bit	7	6	5	4	3	2	1	0
Name	—	—	—	—	—	—	D9	D8
R/W	—	—	—	—	—	—	R/W	R/W
POR	—	—	—	—	—	—	0	0

Bit 7~2 Unimplemented, read as “0”
Bit 1~0 PTM CCRA High Byte Register bit 1 ~ bit 0
PTM 10-bit CCRA bit 9 ~ bit 8

• **PTMnRPL Register**

Bit	7	6	5	4	3	2	1	0
Name	D7	D6	D5	D4	D3	D2	D1	D0
R/W	R/W	R/W	R/W	R/W	R/W	R/W	R/W	R/W
POR	0	0	0	0	0	0	0	0

Bit 7~0 PTM CCRP Low Byte Register bit 7 ~ bit 0
PTM 10-bit CCRP bit 7 ~ bit 0

• **PTMnRPH Register**

Bit	7	6	5	4	3	2	1	0
Name	—	—	—	—	—	—	D9	D8
R/W	—	—	—	—	—	—	R/W	R/W
POR	—	—	—	—	—	—	0	0

Bit 7~2 Unimplemented, read as “0”
Bit 1~0 **PTMnRPH**: PTM CCRP High Byte Register bit 1 ~ bit 0
PTM 10-bit CCRP bit 9 ~ bit 8

Periodic Type TM Operating Modes

The Periodic Type TM can operate in one of five operating modes, Compare Match Output Mode, PWM Output Mode, Single Pulse Output Mode, Capture Input Mode or Timer/Counter Mode. The operating mode is selected using the PTnM1 and PTnM0 bits in the PTMnC1 register.

Compare Match Output Mode

To select this mode, bits PTnM1 and PTnM0 in the PTMnC1 register, should be all cleared to 00 respectively. In this mode once the counter is enabled and running it can be cleared by three methods. These are a counter overflow, a compare match from Comparator A and a compare match from Comparator P. When the PTnCCLR bit is low, there are two ways in which the counter can be cleared. One is when a compare match occurs from Comparator P, the other is when the CCRP bits are all zero which allows the counter to overflow. Here both the PTMAnF and PTMPnF interrupt request flags for Comparator A and Comparator P respectively, will both be generated.

If the PTnCCLR bit in the PTMnC1 register is high then the counter will be cleared when a compare match occurs from Comparator A. However, here only the PTMAnF interrupt request flag will be generated even if the value of the CCRP bits is less than that of the CCRA registers. Therefore when PTnCCLR is high no PTMPnF interrupt request flag will be generated. In the Compare Match Output Mode, the CCRA can not be set to "0". If the CCRA bits are all zero, the counter will overflow when it reaches its maximum 10-bit, 3FF Hex, value, however here the PTMAnF interrupt request flag will not be generated.

As the name of the mode suggests, after a comparison is made, the TM output pin, will change state. The TM output pin condition however only changes state when a PTMAnF interrupt request flag is generated after a compare match occurs from Comparator A. The PTMPnF interrupt request flag, generated from a compare match from Comparator P, will have no effect on the TM output pin. The way in which the TM output pin changes state are determined by the condition of the PTnIO1 and PTnIO0 bits in the PTMnC1 register. The TM output pin can be selected using the PTnIO1 and PTnIO0 bits to go high, to go low or to toggle from its present condition when a compare match occurs from Comparator A. The initial condition of the TM output pin, which is setup after the PTnON bit changes from low to high, is setup using the PTnOC bit. Note that if the PTnIO1, PTnIO0 bits are zero then no pin change will take place.

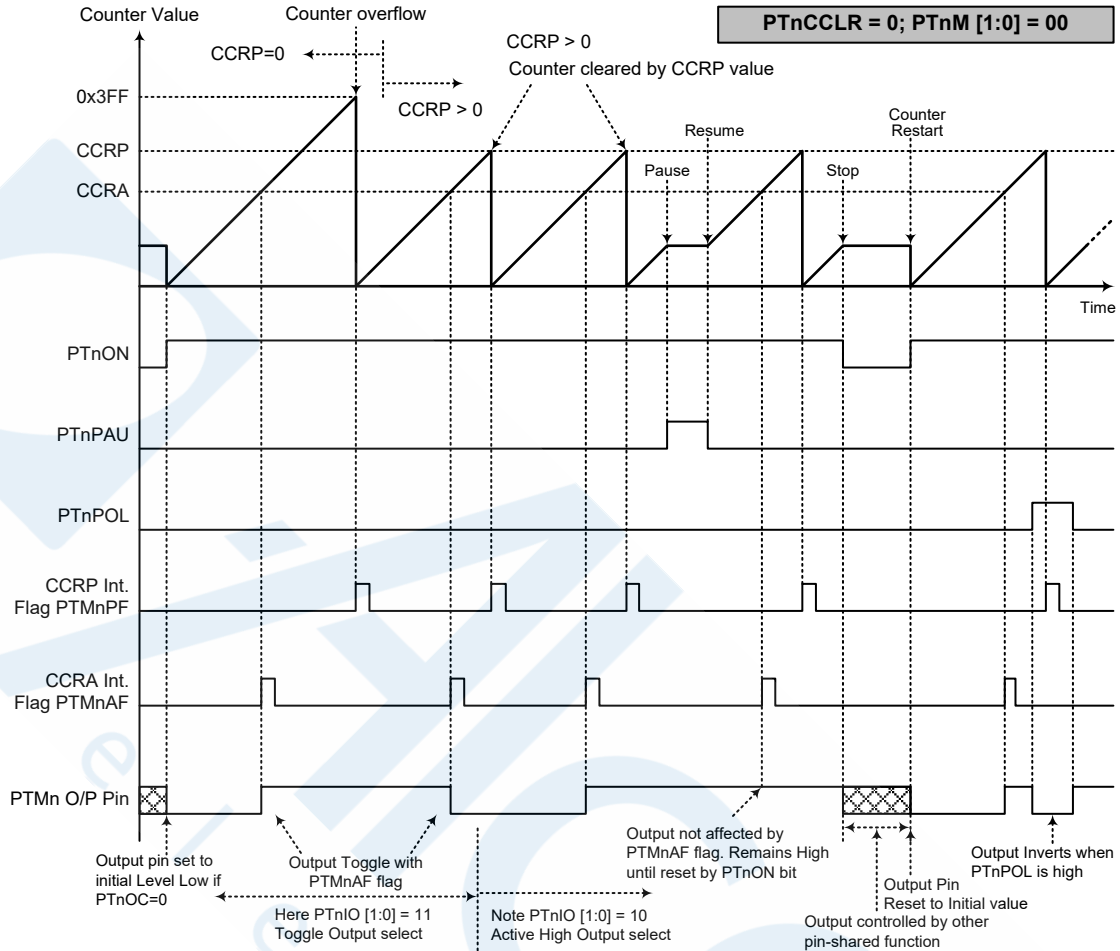

Compare Match Output Mode – PTnCCR=0 (n=1)

- Note: 1. With PTnCCR=0 – a Comparator P match will clear the counter
 2. The TM output pin is controlled only by the PTMnAF flag
 3. The output pin is reset to initial state by a PTnON bit rising edge

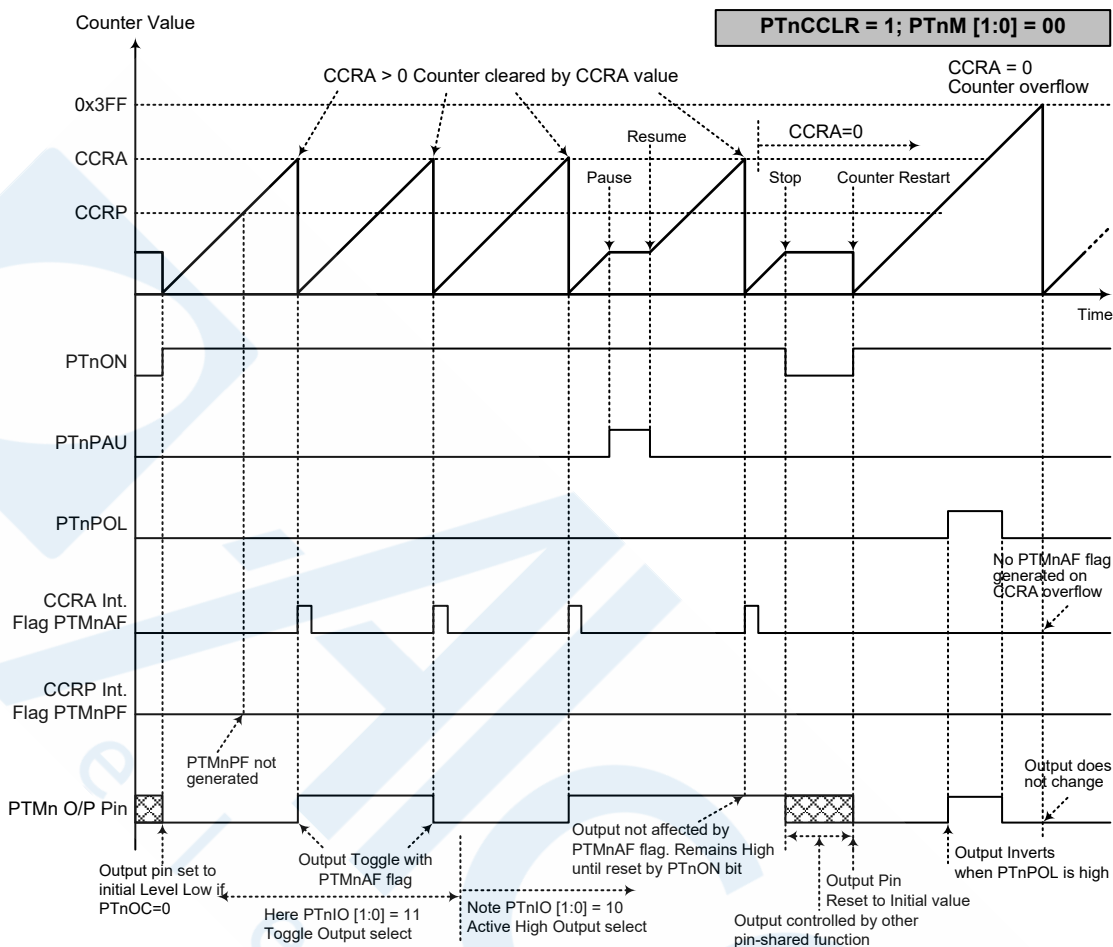

Compare Match Output Mode – PTnCCLR=1 (n=1)

- Note: 1. With PTnCCLR=1 – a Comparator A match will clear the counter
 2. The TM output pin is controlled only by the PTMnAF flag
 3. The output pin is reset to initial state by a PTnON rising edge
 4. The PTMnPF flag is not generated when PTnCCLR=1

Timer/Counter Mode

To select this mode, bits PTnM1 and PTnM0 in the PTMnC1 register should all be set to 11 respectively. The Timer/Counter Mode operates in an identical way to the Compare Match Output Mode generating the same interrupt flags. The exception is that in the Timer/Counter Mode the TM output pin is not used. Therefore the above description and Timing Diagrams for the Compare Match Output Mode can be used to understand its function. As the TM output pin is not used in this mode, the pin can be used as a normal I/O pin or other pin-shared function.

PWM Output Mode

To select this mode, bits PTnM1 and PTnM0 in the PTMnC1 register should be set to 10 respectively and also the PTnIO1 and PTnIO0 bits should be set to 10 respectively. The PWM function within the TM is useful for applications which require functions such as motor control, heating control, illumination control etc. By providing a signal of fixed frequency but of varying duty cycle on the TM output pin, a square wave AC waveform can be generated with varying equivalent DC RMS values.

As both the period and duty cycle of the PWM waveform can be controlled, the choice of generated waveform is extremely flexible. In the PWM mode, the PTnCCLR bit has no effect as the PWM period. Both of the CCRP and CCRA registers are used to generate the PWM waveform, one register is used to clear the internal counter and thus control the PWM waveform frequency, while the other one is used to control the duty cycle. The PWM waveform frequency and duty cycle can therefore be controlled by the values in the CCRA and CCRP registers.

An interrupt flag, one for each of the CCRA and CCRP, will be generated when a compare match occurs from either Comparator A or Comparator P. The PTnOC bit in the PTMnC1 register is used to select the required polarity of the PWM waveform while the two PTnIO1 and PTnIO0 bits are used to enable the PWM output or to force the TM output pin to a fixed high or low level. The PTnPOL bit is used to reverse the polarity of the PWM output waveform.

• 10-bit PWM Mode, Edge-aligned Mode

CCRP	CCRP=0~1024
Period	CCRP=0 : period=1024 clocks CCRP=1~1023: period=1~1023 clocks
Duty	CCRA

If $f_{SYS}=8\text{MHz}$, PTM clock source select $f_{SYS}/4$, CCRP=512 and CCRA=128,

The PTM PWM output frequency= $(f_{SYS}/4)/512=f_{SYS}/2048=3.9063\text{kHz}$, duty= $128/512=25\%$

If the Duty value defined by the CCRA register is equal to or greater than the Period value, then the PWM output duty is 100%.

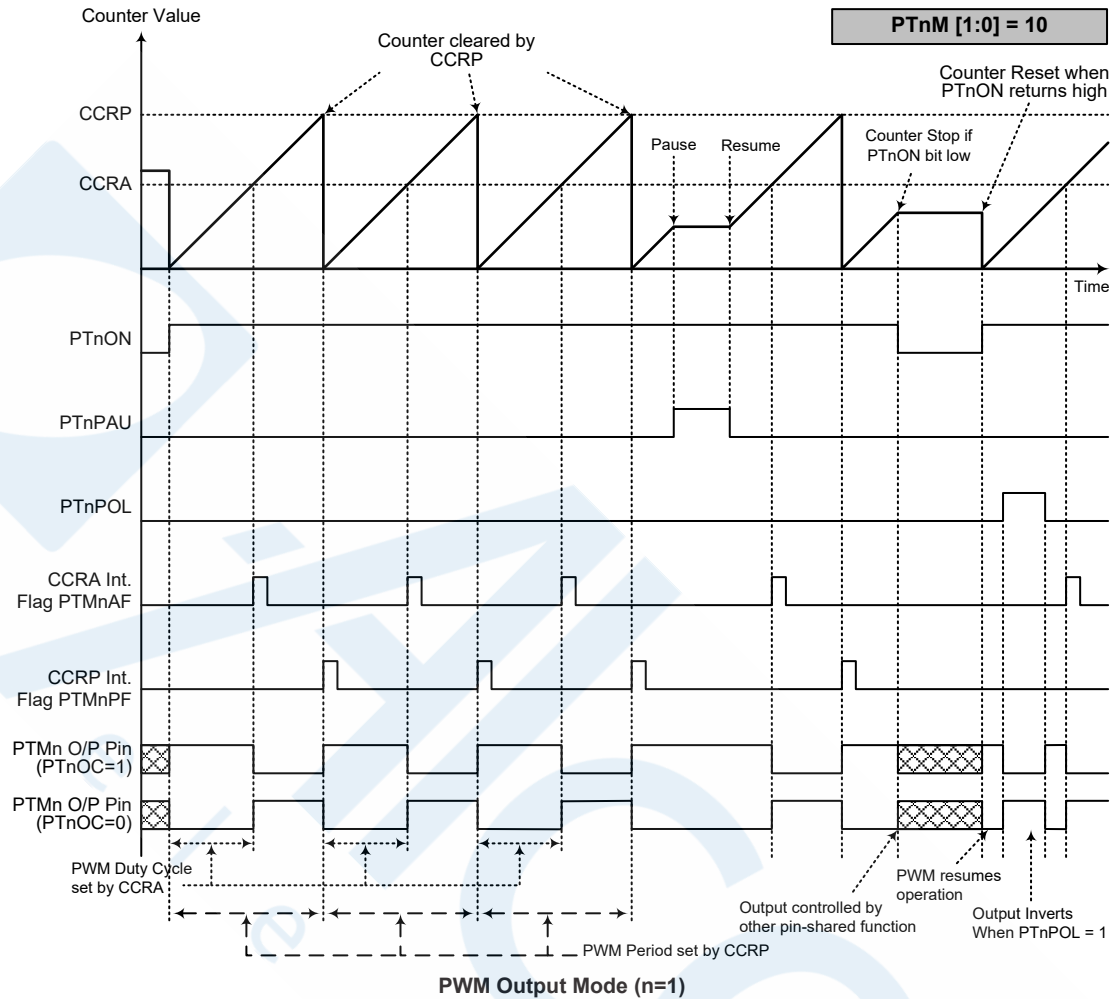

- Note:
1. Here Counter cleared by CCRP
 2. A counter clear sets the PWM Period
 3. The internal PWM function continues running even when PTnIO[1:0]=00 or 01
 4. The PTnCCLR bit has no influence on PWM operation

Single Pulse Output Mode

To select this mode, the required bit pairs, PTnM1 and PTnM0 should be set to 10 respectively and also the corresponding PTnIO1 and PTnIO0 bits should be set to 11 respectively. The Single Pulse Output Mode, as the name suggests, will generate a single shot pulse on the TM output pin.

The trigger for the pulse output leading edge is a low to high transition of the PTnON bit, which can be implemented using the application program. However in the Single Pulse Mode, the PTnON bit can also be made to automatically change from low to high using the external PTCKn pin, which will in turn initiate the Single Pulse output. When the PTnON bit transitions to a high level, the counter will start running and the pulse leading edge will be generated. The PTnON bit should remain high when the pulse is in its active state. The generated pulse trailing edge will be generated when the PTnON bit is cleared to zero, which can be implemented using the application program or when a compare match occurs from Comparator A.

However a compare match from Comparator A will also automatically clear the PTnON bit and thus generate the Single Pulse output trailing edge. In this way the CCRA value can be used to control the pulse width. A compare match from Comparator A will also generate TM interrupts. The counter can only be reset back to zero when the PTnON bit changes from low to high when the counter restarts. In the Single Pulse Mode CCRP is not used. The PTnCCLR bit is also not used.

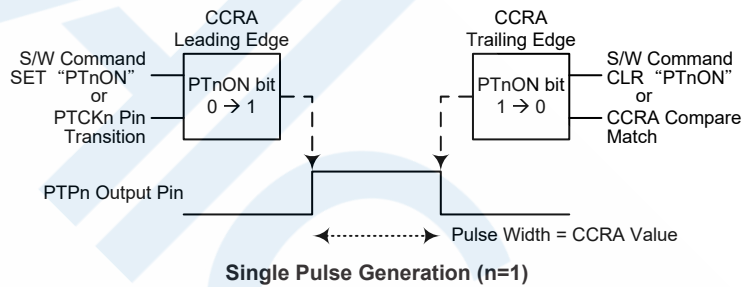

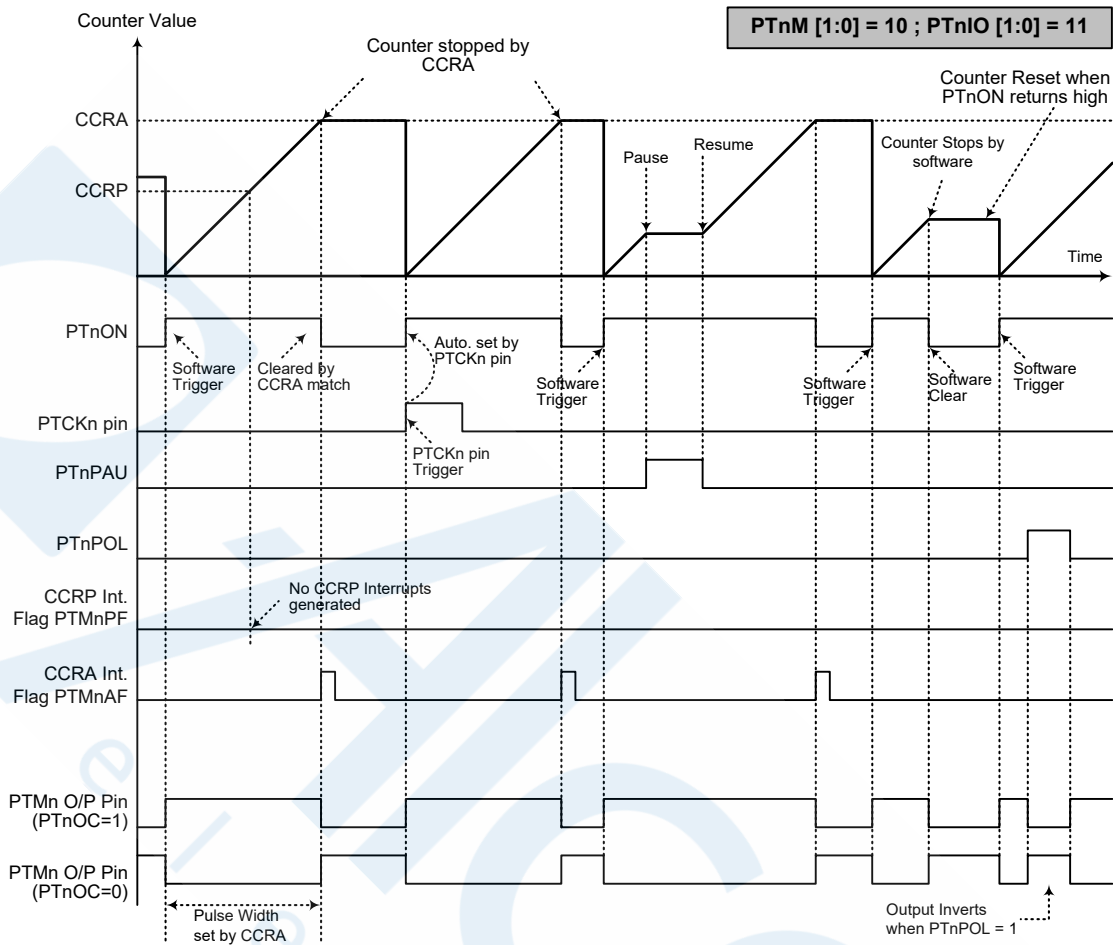

Single Pulse Output Mode

- Note:
1. Counter stopped by CCRA
 2. CCRP is not used
 3. The pulse is triggered by the PTCKn pin or by setting the PTnON bit high
 4. A PTCKn pin active edge will automatically set the PTnON bit high
 5. In the Single Pulse Mode, PTnIO[1:0] must be set to "11" and can not be changed

Capture Input Mode

To select this mode bits PTnM1 and PTnM0 in the PTMnC1 register should be set to 01 respectively. This mode enables external signals to capture and store the present value of the internal counter and can therefore be used for applications such as pulse width measurements. The external signal is supplied on the PTPnI or PTCKn pin, selected by the PTnCKS bit in the PTMnC1 register. The input pin active edge can be either a rising edge, a falling edge or both rising and falling edges; the active edge transition type is selected using the PTnIO1 and PTnIO0 bits in the PTMnC1 register. The counter is started when the PTnON bit changes from low to high which is initiated using the application program.

When the required edge transition appears on the PTPnI or PTCKn pin the present value in the counter will be latched into the CCRA register and a TM interrupt generated. Irrespective of what events occur on the PTPnI or PTCKn pin the counter will continue to free run until the PTnON bit changes from high to low. When a CCRP compare match occurs the counter will reset back to zero; in this way the CCRP value can be used to control the maximum counter value. When a CCRP compare match occurs from Comparator P, a TM interrupt will also be generated. Counting the number of overflow interrupt signals from the CCRP can be a useful method in measuring long pulse widths. The PTnIO1 and PTnIO0 bits can select the active trigger edge on the PTPnI or PTCKn pin to be a rising edge, falling edge or both edge types. If the PTnIO1 and PTnIO0 bits are both set high, then no capture operation will take place irrespective of what happens on the PTPnI or PTCKn pin, however it must be noted that the counter will continue to run. The PTnCCLR, PTnOC and PTnPOL bits are not used in this mode.

There are some considerations that should be noted. If PTCKn is used as the capture input source, then it cannot be selected as the PTMn clock source. If the captured pulse width is less than 2 timer clock periods, it may be ignored by hardware. After the counter value is latched to the CCRA registers by an active capture edge, the PTMAnF flag will be set high after 0.5 timer clock period. The delay time from the active capture edge received to the action of latching counter value to CCRA registers is less than 1.5 timer clock periods.

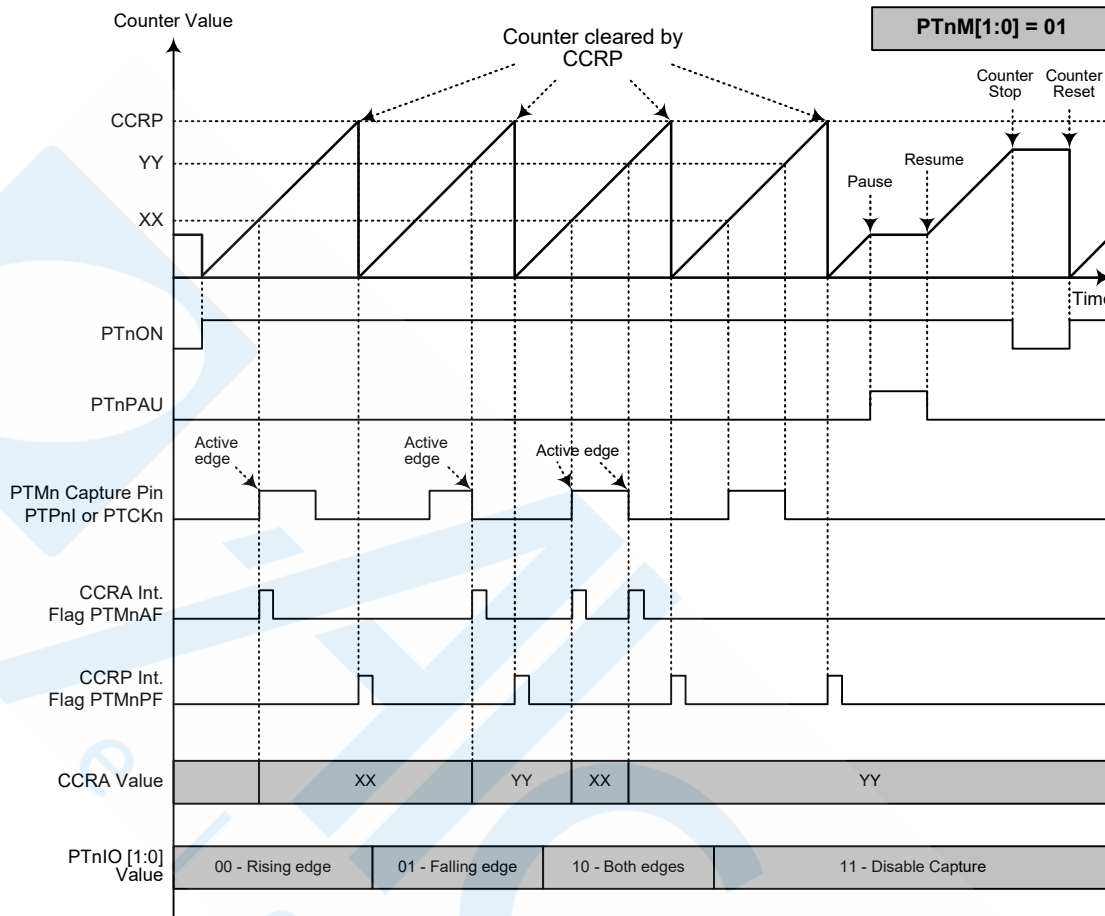

Capture Input Mode (n=1)

- Note: 1. PTnM[1:0]=01 and active edge set by the PTnIO[1:0] bits
 2. A TM Capture input pin active edge transfers counter value to CCRA
 3. The PTnCCLR bit is not used
 4. No output function – PTnOC and PTnPOL bits are not used
 5. CCRP determines the counter value and the counter has a maximum count value when CCRP is equal to zero

Analog to Digital Converter

The need to interface to real world analog signals is a common requirement for many electronic systems. However, to properly process these signals by a microcontroller, they must first be converted into digital signals by A/D converters. By integrating the A/D conversion electronic circuitry into the microcontroller, the need for external components is reduced significantly with the corresponding follow-on benefits of lower costs and reduced component space requirements.

A/D Overview

The device contains a multi-channel analog to digital converter which can directly interface to external analog signals, such as that from sensors or other control signals and convert these signals directly into a 12-bit digital value. The external or internal analog signal to be converted is determined by the SAINS and SACS bit fields. Note that when the internal analog signal is to be converted, the pin-shared control bits should also be properly configured except the SAINS and SACS bit fields. More detailed information about the A/D input signal is described in the “A/D Converter Control Registers” and “A/D Converter Input Signal” sections respectively.

Input Channels	A/D Channel Select Bits	Input Pins
3: AN0~AN24	6: AV _{DD} , AV _{DD} /2, AV _{DD} /4, V _R , V _R /2, V _R /4	SAINS2~SAINS0, SACS1~SACS0

The accompanying block diagram shows the overall internal structure of the A/D converter, together with its associated registers.

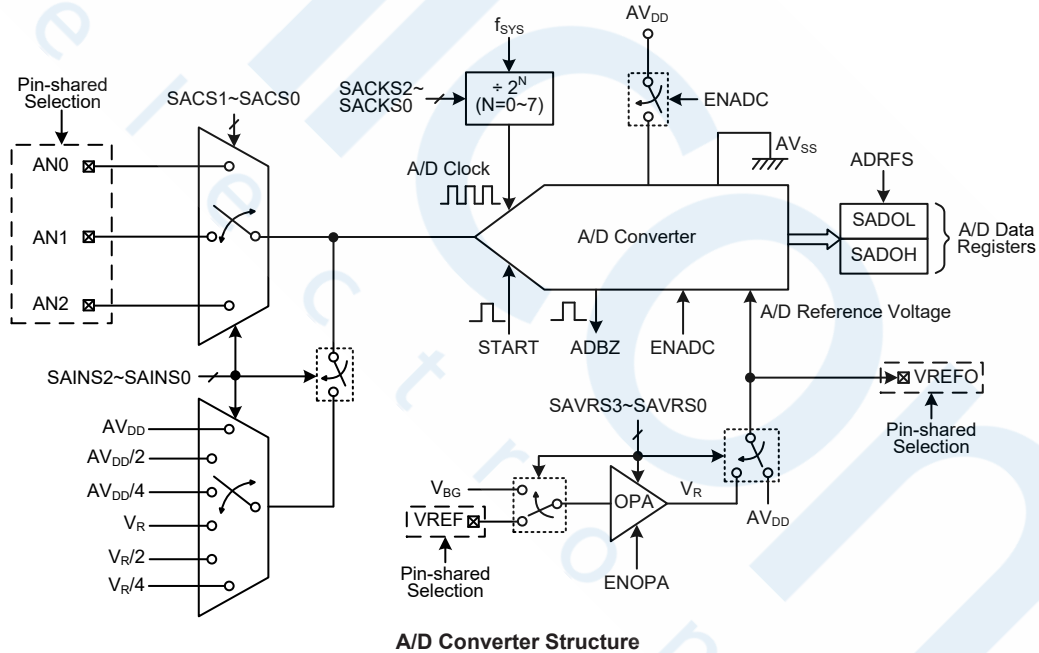

A/D Converter Structure

A/D Converter Register Description

Overall operation of the A/D converter is controlled using five registers. A read only register pair exists to store the ADC data 12-bit value. The remaining three registers are control registers which setup the operating and control function of the A/D converter.

Name	Bit							
	7	6	5	4	3	2	1	0
SADOL (ADRFS=0)	D3	D2	D1	D0	—	—	—	—
SADOL (ADRFS=1)	D7	D6	D5	D4	D3	D2	D1	D0
SADOH (ADRFS=0)	D11	D10	D9	D8	D7	D6	D5	D4
SADOH (ADRFS=1)	—	—	—	—	D11	D10	D9	D8
SADC0	START	ADBZ	ENADC	ADRFS	—	—	SACS1	SACS0
SADC1	SAINS2	SAINS1	SAINS0	—	—	SACK2	SACK1	SACK0
SADC2	ENOPA	VBGEN	—	—	SAVRS3	SAVRS2	SAVRS1	SAVRS0

A/D Converter Register List

A/D Converter Data Registers – SADOL, SADOH

As the device contains an internal 12-bit A/D converter, it requires two data registers to store the converted value. These are a high byte register, known as SADOH, and a low byte register, known as SADOL. After the conversion process takes place, these registers can be directly read by the microcontroller to obtain the digitised conversion value. As only 12 bits of the 16-bit register space is utilised, the format in which the data is stored is controlled by the ADRFS bit in the SADC0 register as shown in the accompanying table. D0~D11 are the A/D conversion result data bits. Any unused bits will be read as zero. Note that the A/D converter data register contents will not be cleared to zero if the A/D converter is disabled.

ADRFS	SADOH								SADOL							
	7	6	5	4	3	2	1	0	7	6	5	4	3	2	1	0
0	D11	D10	D9	D8	D7	D6	D5	D4	D3	D2	D1	D0	0	0	0	0
1	0	0	0	0	D11	D10	D9	D8	D7	D6	D5	D4	D3	D2	D1	D0

A/D Data Registers

A/D Converter Control Registers – SADC0, SADC1, SADC2, PASR, PBSR

To control the function and operation of the A/D converter, several control registers known as SADC0, SADC1 and SADC2 are provided. These 8-bit registers define functions such as the selection of which analog channel is connected to the internal A/D converter, the digitised data format, the A/D clock source as well as controlling the start function and monitoring the A/D converter busy status. The SACS2~SACS0 bits in the SADC0 register are used to determine which external channel input is selected to be converted. The SAINS2~SAINS0 bits in the SADC1 register are used to determine that the analog signal to be converted comes from the internal analog signal or external analog channel input. If the SAINS2~SAINS0 bits are set to “000”, the external analog channel input is selected to be converted and the SACS2~SACS0 bits can determine which external channel is selected to be converted. If the SAINS2~SAINS0 bits are set to “001~011”, the AV_{DD} voltage is selected to be converted. If the SAINS2~SAINS0 bits are set to “101~111”, the OPA output voltage is selected to be converted. When V_{REF} or V_{BG} is selected as ADC input or ADC reference voltage, the OPA needs to be enabled by setting ENOPA to 1.

Note that when the programs select external signal and internal signal as an ADC input signal simultaneously, then the hardware will only choose the internal signal as an ADC input. In addition, if the programs select external reference voltage V_{REF} and the internal reference voltage V_{BG} as ADC reference voltage, then the hardware will only choose the internal reference voltage V_{BG} as an ADC reference voltage input.

The pin-shared function control registers, named PASR and PBSR, contain the corresponding pin-shared selection bits which determine which pins on Port A and Port B are used as analog inputs for the A/D converter input and which pins are not to be used as the A/D converter input. When the pin is selected to be an A/D input, its original function whether it is an I/O or other pin-shared function will be removed. In addition, any internal pull-high resistors connected to these pins will be automatically removed if the pin is selected to be an A/D input.

• **SADC0 Register**

Bit	7	6	5	4	3	2	1	0
Name	START	ADBZ	ENADC	ADRFS	—	—	SACS1	SACS0
R/W	R/W	R	R/W	R/W	—	—	R/W	R/W
POR	0	0	0	0	—	—	0	0

- Bit 7 START:** Start the A/D conversion
0→1→0: Start A/D conversion
This bit is used to initiate an A/D conversion process. The bit is normally low but if set high and then cleared to zero again, the A/D Converter will initiate a conversion process.
- Bit 6 ADBZ:** ADC busy flag
0: A/D conversion ended or no conversion
1: A/D is busy
This read only flag is used to indicate whether the A/D conversion is in progress or not. When the START bit is set from low to high and then to low again, the ADBZ flag will be set high to indicate that the A/D conversion is initiated. The ADBZ flag will be cleared to zero after the A/D conversion is complete.
- Bit 5 ENADC:** ADC enable/disable control register
0: ADC disable
1: ADC enable
When the A/D Converter function is disabled, the contents of the A/D Converter data register pair, SADOH and SADOL, will be cleared to zero.
- Bit 4 ADRFS:** A/D output data format selection bit
0: ADC output data format → SADOH=D[11:4]; SADOL=D[3:0]
1: ADC output data format → SADOH=D[11:8]; SADOL=D[7:0]
- Bit 3~2** Unimplemented, read as “0”
- Bit 1~0 SACS1~SACS0:** ADC external input channels selection
00: ADC external input channel comes from AN0
01: ADC external input channel comes from AN1
10: ADC external input channel comes from AN2
11: ADC external input channel comes from AN3

• **SADC1 Register**

Bit	7	6	5	4	3	2	1	0
Name	SAINS2	SAINS1	SAINS0	—	—	SACKS2	SACKS1	SACKS0
R/W	R/W	R/W	R/W	—	—	R/W	R/W	R/W
POR	0	0	0	—	—	0	0	0

- Bit 7~5 SAINS2~SAINS0:** ADC input channel selection bit
000: ADC input comes from external pin
001: ADC input comes from AV_{DD}

- 010: ADC input comes from $AV_{DD}/2$
- 011: ADC input comes from $AV_{DD}/4$
- 100: ADC input comes from external pin
- 101: ADC input comes from V_R
- 110: ADC input comes from $V_R/2$
- 111: ADC input comes from $V_R/4$

Note: V_R is OPA output voltage. V_R can be one of VREF pin voltage $\times 1/\times 2/\times 3/\times 4$ or $V_{BG} \times 2/V_{BG} \times 3/V_{BG} \times 4$.

When the bits are set to 001~011 or 101~111 to select the internal signal as an ADC input signal, then the external channel input selected by the SACS1~SACS0 bits will be automatically disconnected.

Bit 4~3
Bit 2~0

Unimplemented, read as "0"

SACKS2~SACKS0: ADC clock rate selection bit

- 000: f_{SYS}
- 001: $f_{SYS}/2$
- 010: $f_{SYS}/4$
- 011: $f_{SYS}/8$
- 100: $f_{SYS}/16$
- 101: $f_{SYS}/32$
- 110: $f_{SYS}/64$
- 111: $f_{SYS}/128$

• **SADC2 Register**

Bit	7	6	5	4	3	2	1	0
Name	ENOPA	VBGEN	—	—	SAVRS3	SAVRS2	SAVRS1	SAVRS0
R/W	R/W	R/W	—	—	R/W	R/W	R/W	R/W
POR	0	0	—	—	0	0	0	0

Bit 7 **ENOPA**: OPA enable/disable control register

- 0: OPA disable
- 1: OPA enable

Bit 6 **VBGEN**: Bandgap buffer disable/enable control bit

- 0: Bandgap buffer disable
- 1: Bandgap buffer enable

Bit 5~4 Unimplemented, read as "0"

Bit 3~0 **SAVRS3~SAVRS0**: ADC reference voltage selection bit

- 0000: ADC reference voltage comes from AV_{DD}
- 0001: ADC reference voltage comes from VREF pin voltage
- 0010: ADC reference voltage comes from VREF pin voltage $\times 2$
- 0011: ADC reference voltage comes from VREF pin voltage $\times 3$
- 0100: ADC reference voltage comes from VREF pin voltage $\times 4$
- 1001: Inhibit to use
- 1010: ADC reference voltage comes from $V_{BG} \times 2$
- 1011: ADC reference voltage comes from $V_{BG} \times 3$
- 1100: ADC reference voltage comes from $V_{BG} \times 4$
- Other Values: same as 0000

Note: (1) When Select VREF pin voltage $\times 1/\times 2/\times 3/\times 4$ as ADC reference voltage, the PAS3~PAS2 bits in the PASR register should be set to 10 to select the VREF pin function.

(2) $V_{BG}=1.04V$

(3) When SAVRS[3:0]=1010~1100, OPA selects V_{BG} as input.

(4) If the internal reference voltage VBG is selected as the ADC reference source, then the external reference source on the VREF pin will be automatically disconnected.

A/D Converter Operation

The START bit is used to start and reset the A/D converter. When the microcontroller sets this bit from low to high and then low again, an analog to digital conversion cycle will be initiated.

The ADBZ bit in the SADC0 register is used to indicate whether the analog to digital conversion process is in process or not. This bit will be automatically set to “1” by the microcontroller after an A/D conversion is successfully initiated. When the A/D conversion is complete, the ADBZ will be cleared to 0. In addition, the corresponding A/D interrupt request flag will be set in the interrupt control register, and if the interrupts are enabled, an appropriate internal interrupt signal will be generated. This A/D internal interrupt signal will direct the program flow to the associated A/D internal interrupt address for processing. If the A/D internal interrupt is disabled, the microcontroller can poll the ADBZ bit in the SADC0 register to check whether it has been cleared as an alternative method of detecting the end of an A/D conversion cycle.

Although the A/D clock source is determined by the system clock f_{SYS} , and by bits SACK2~SACK0, there are some limitations on the A/D clock source speed that can be selected. As the recommended value of permissible A/D clock period, t_{ADCK} , is from 0.5 μ s to 10 μ s, care must be taken for system clock frequencies. For example, if the system clock operates at a frequency of 4MHz, the SACK2~SACK0 bits should not be set to 000B or 11xB. Doing so will give A/D clock periods that are less than the minimum A/D clock period or greater than the maximum A/D clock period which may result in inaccurate A/D conversion values.

Controlling the power on/off function of the A/D converter circuitry is implemented using the ENADC bit in the SADC0 register. This bit must be set high to power on the A/D converter. When the ENADC bit is set high to power on the A/D converter internal circuitry a certain delay, as indicated in the timing diagram, must be allowed before an A/D conversion is initiated. Even if no pins are selected for use as A/D inputs by configuring the corresponding pin-shared control bits, if the ENADC bit is high then some power will still be consumed. In power conscious applications it is therefore recommended that the ENADC is set low to reduce power consumption when the A/D converter function is not being used.

A/D Converter Reference Voltage

The reference voltage supply to the A/D Converter can be supplied from either the internal ADC power or from an external reference sources supplied on pin VREF or V_{BG} voltage. The desired selection is made using the SAVRS3~SAVRS0 bits. As the VREF pin is pin-shared with other functions, when the VREF pin is selected as the reference voltage supply pin, the VREF pin-shared function control bits should be properly configured to disable other pin functions. When the external reference voltage on the VREF pin or V_{BG} is selected as ADC input or ADC reference voltage, the OPA needs to be enabled by setting ENOPA=1.

SAVRS[3:0]	Reference	Description
0000	AV_{DD}	ADC Reference Voltage comes from AV_{DD}
0001	Pin voltage	ADC Reference Voltage comes from external VREF pin voltage
0010	Pin voltage $\times 2$	ADC Reference Voltage comes from external VREF pin voltage $\times 2$
0011	Pin voltage $\times 3$	ADC Reference Voltage comes from external VREF pin voltage $\times 3$
0100	Pin voltage $\times 4$	ADC Reference Voltage comes from external VREF pin voltage $\times 4$
1010	$V_{BG} \times 2$	ADC Reference Voltage comes from $V_{BG} \times 2$
1011	$V_{BG} \times 3$	ADC Reference Voltage comes from $V_{BG} \times 3$
1100	$V_{BG} \times 4$	ADC Reference Voltage comes from $V_{BG} \times 4$

A/D Converter Reference Voltage Selection

A/D Converter Input Signals

All of the A/D analog input pins are pin-shared with the I/O pins on Port A and Port B as well as other functions. The corresponding selection bits for each I/O pin in the PASR and PBSR registers, determine whether the input pins are setup as A/D converter analog inputs or whether they have other functions. If the pin-shared function control bits configure its corresponding pin as an A/D analog channel input, the pin will be setup to be an A/D converter external channel input and the original pin functions disabled. In this way, pins can be changed under program control to change their function between A/D inputs and other functions. All pull-high resistors, which are setup through register programming, will be automatically disconnected if the pins are setup as A/D inputs. Note that it is not necessary to first setup the A/D pin as an input in the PAC and PBC port control register to enable the A/D input as when the pin-shared function control bits enable an A/D input, the status of the port control register will be overridden.

The A/D converter has its own reference voltage pin, VREF, however the reference voltage can also be supplied from the power supply pin, a choice which is made through the SAVRS[3:0] bits in the SADC2 register. The analog input values must not be allowed to exceed the selected reference voltage value.

Conversion Rate and Timing Diagram

A complete A/D conversion contains two parts, data sampling and data conversion. The data sampling which is defined as t_{ADS} takes 4 A/D clock cycles and the data conversion takes 12 A/D clock cycles. Therefore a total of 16 A/D clock cycles for an A/D conversion which is defined as t_{ADC} are necessary.

$$\text{Maximum single A/D conversion rate} = 1/(\text{A/D clock period} \times 16)$$

However, there is a usage limitation on the next A/D conversion after the current conversion is complete. When the current A/D conversion is complete, the converted digital data will be stored in the A/D data register pair and then latched after half an A/D clock cycle. If the START bit is set to 1 in half an A/D clock cycle after the end of A/D conversion, the converted digital data stored in the A/D data register pair will be changed. Therefore, it is recommended to initiate the next A/D conversion after a certain period greater than half an A/D clock cycle at the end of current A/D conversion.

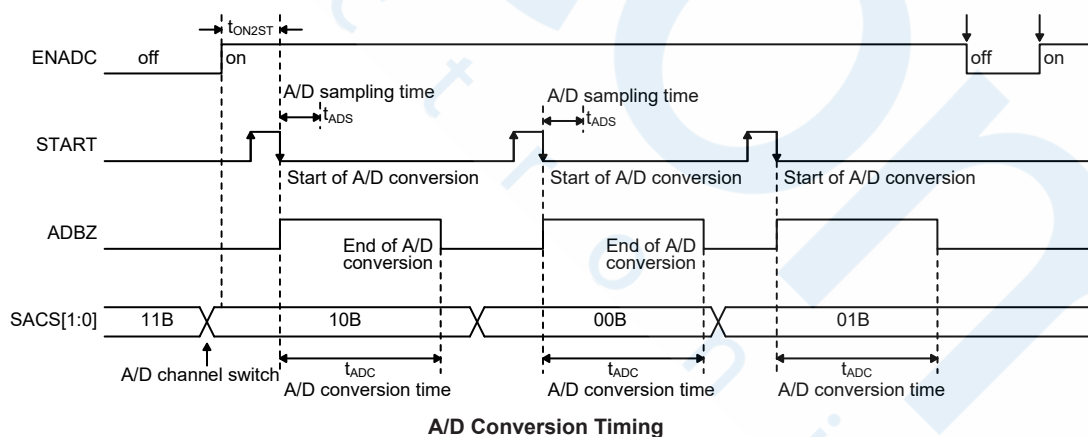

Summary of A/D Conversion Steps

The following summarises the individual steps that should be executed in order to implement an A/D conversion process.

- Step 1
Select the required A/D conversion frequency by SACKS2~ SACKS0.
- Step 2
Enable the ADC by set setting ENADC to 1.
- Step 3
Select which signal will be configured as ADC analog input.
- Step 4
If the ADC analog input comes from the external channel input by setting the SAINS bit field, the corresponding pin should be configured as ADC input function by configuring the relevant pin-shared control bits. Then set the SACS bit field to select the desired external channel input. If the ADC analog input comes from the internal signal, set the SAINS bit field to select the desired internal input source.
- Step 5
Select reference voltage by setting the SAVRS3~SAVRS0 bits.
Note: If the reference voltage is selected to come from the external VREF pin, the PAS3~PAS2 bits in the PASR register should be set to 10 to select the VREF pin function.
- Step 6
Select ADC output data format by ADRFS
- Step 7
If ADC interrupt is used, the interrupt control registers must be correctly configured to ensure the A/D interrupt function is active. The master interrupt control bit, EMI, and the A/D converter interrupt bits, ADE, must both set high in advance.
- Step 8
The A/D conversion procedure can now be initialized by setting START from low to high and then low again
- Step 9
If ADC is under conversion, ADBZ=1. After A/D conversion process is completed, the ADBZ flag will go low, and then output data can be read from SADOH and SADOL registers. If the ADC interrupt is enabled and the stack is not full, data can be acquired by interrupt service program. Another way to get the A/D output data is polling the ADBZ flag.

Programming Considerations

During microcontroller operations where the A/D converter is not being used, the A/D internal circuitry can be switched off to reduce power consumption, by clearing the ENADC bit in the SADC0 register. When this happens, the internal A/D converter circuits will not consume power irrespective of what analog voltage is applied to their input lines. If the A/D converter input lines are used as normal I/Os, then care must be taken as if the input voltage is not at a valid logic level, then this may lead to some increase in power consumption.

A/D Conversion Function

As the device contains a 12-bit A/D converter, its full-scale converted digitised value is equal to FFFH. Since the full-scale analog input value is equal to the actual A/D converter reference voltage, this gives a single bit analog input value of V_{REF} divided by 4096.

$$1 \text{ LSB} = V_{REF} \div 4096$$

The A/D Converter input voltage value can be calculated using the following equation:

$$\text{A/D input voltage} = \text{A/D output digital value} \times (V_{\text{REF}} \div 4096)$$

The diagram shows the ideal transfer function between the analog input value and the digitised output value for the A/D converter. Except for the digitised zero value, the subsequent digitised values will change at a point 0.5 LSB below where they would change without the offset, and the last full scale digitised value will change at a point 1.5 LSB below the V_{REF} level. Note that here the V_{REF} voltage is the actual A/D Converter reference voltage determined by the SAVRS bit field.

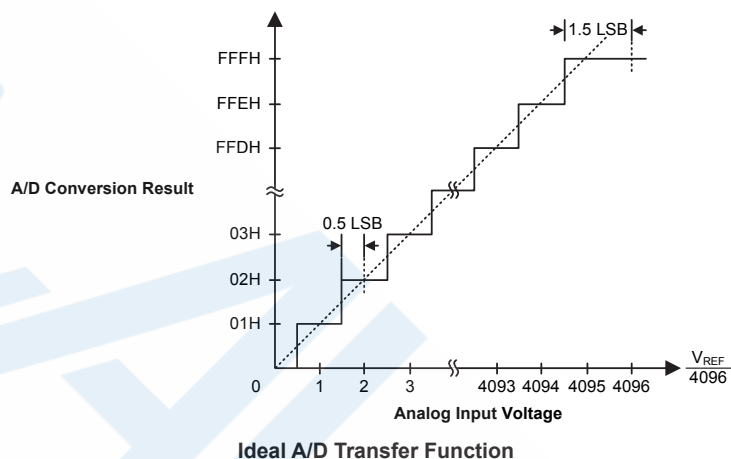

A/D Programming Examples

The following two programming examples illustrate how to setup and implement an A/D conversion. In the first example, the method of polling the ADBZ bit in the SADC0 register is used to detect when the conversion cycle is complete, whereas in the second example, the A/D interrupt is used to determine when the conversion is complete.

Example: using an EOCB polling method to detect the end of conversion

```

clr ADE                ; disable ADC interrupt
mov a,03H
mov SADC1,a            ; select fsys/8 as A/D clock and select external channel input
set ENADC
mov a,03h              ; setup PASR to configure pin AN0
mov PASR,a
mov a,20h
mov SADC0,a           ; enable A/D converter and connect AN0 channel to A/D converter
:
start_conversion:
clr START              ; high pulse on start bit to initiate conversion
set START              ; reset A/D
clr START              ; start A/D
polling_EOC:
sz ADBZ                ; poll the SADC0 register ADBZ bit to detect end of A/D conversion
jmp polling_EOC        ; continue polling
mov a,SADOL             ; read low byte conversion result value
mov SADOL_buffer,a     ; save result to user defined register
mov a,SAD0H            ; read high byte conversion result value
mov SAD0H_buffer,a     ; save result to user defined register
:
:
jmp start_conversion   ; start next a/d conversion

```

Example: using the interrupt method to detect the end of conversion

```

clr ADE                ; disable ADC interrupt
mov a,03H
mov SADC1,a           ; select fsys/8 as A/D clock and select external channel input
set ENADC
mov a,03h            ; setup PASR to configure pin AN0
mov PASR,a
mov a,20h
mov SADC0,a          ; enable A/D converter and connect AN0 channel to A/D converter
Start_conversion:
clr START            ; high pulse on START bit to initiate conversion
set START            ; reset A/D
clr START            ; start A/D
clr ADF              ; clear ADC interrupt request flag
set ADE              ; enable ADC interrupt
set EMI              ; enable global interrupt
:
:
; ADC interrupt service routine
ADC_ISR:
mov acc_stack,a      ; save ACC to user defined memory
mov a,STATUS
mov status_stack,a   ; save STATUS to user defined memory
:
:
mov a,SADOL          ; read low byte conversion result value
mov SADOL_buffer,a   ; save result to user defined register
mov a,SADOH          ; read high byte conversion result value
mov SADOH_buffer,a   ; save result to user defined register
:
:
EXIT_INT_ISR:
mov a,status_stack
mov STATUS,a         ; restore STATUS from user defined memory
mov a,acc_stack      ; restore ACC from user defined memory
reti

```

RF Transmitter

The RF module is a low cost sub-GHz OOK/FSK transmitter for wireless applications in the 315MHz, 433MHz, 470MHz, 868MHz and 915MHz frequency bands. It consists of a highly integrated fractional-N Synthesizer and a Class-E Power Amplifier (PA).

The RF frequency is generated by a fully integrated fractional-N Synthesizer which includes RF VCO, loop filter and Digital controlled XO (DCXO). A fractional-N synthesizer allows users to extend their applications to a wider frequency range with the same XO.

The transmit session is a VCO direct modulation architecture. Different from the conventional direct-up conversion transmitter, the FSK modulation signal is fed into the VCO directly to take advantage of fractional-N synthesizer. As a result, both layout area and current consumption are much smaller. The modulated signal, generated by VCO, is fed into a Class-E PA and the maximum output power can be up to +13dBm.

Note that the data rate of the RF module is determined by the integrated oscillator source (HIRC), and the receive end is recommended to use firmware decoding products such as Holtek BC2502 + BC68F0031.

State Control

The RF transmitter has integrated state machines that control the state transition between modes.

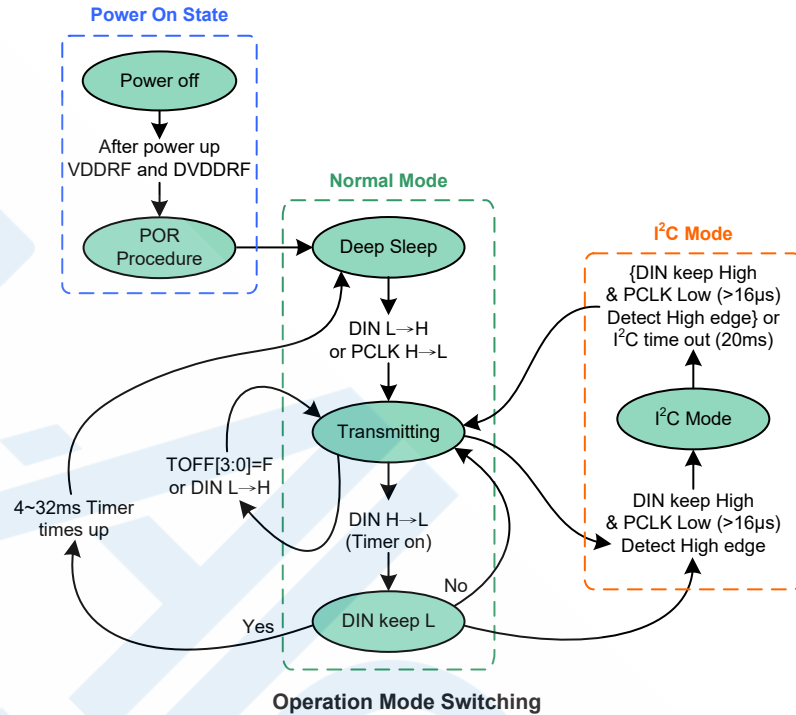

Normal Mode

After a power-on reset operation, the RF Transmitter will perform a POR procedure and then automatically enter the Deep Sleep Mode to wait for a transmitting start condition. Data will be transmitted if the DIN pin is pulled high or the pulse on the PCLK pin changes from high to low. When data transmission is finished and the DIN pin state changes from high to low, the RF Transmitter will enter the Standby state and the Timer, whose timeout period is determined by DLY_TOFF bits in the CFG1 register, will turn on and start to count. The RF Transmitter will return to the Deep Sleep Mode when the Timer overflows. However, it should be noted that when the DLY_TOFF[3:0] bit value is “1111”, the device will start to transmit again without entering the Deep Sleep Mode once the DIN pin state changes from low to high.

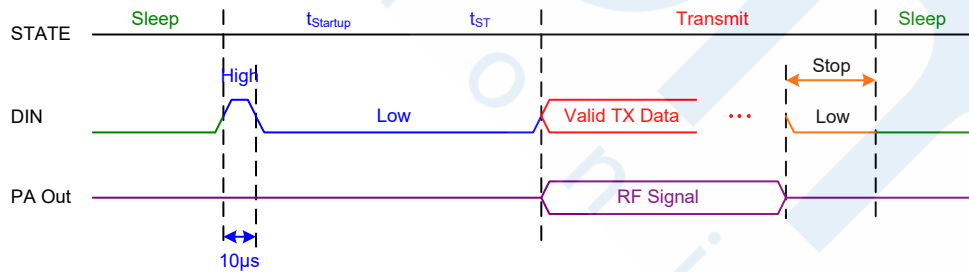

I²C Mode

The RF transmitter can enter the I²C mode from the Normal mode. If the PCLK line is pulled low and stays at low level for more than 16μs, the RF transmitter enters the I²C Mode for serial programming. When the RF receives a correct I²C STOP signal followed by the PCLK line pulled low and stay at low level for more than 16μs, the RF transmitter will return to the Normal Mode.

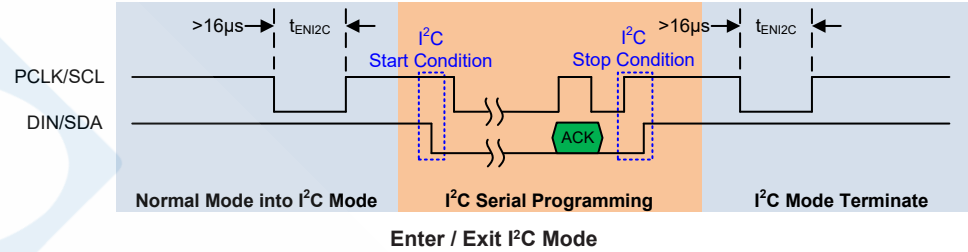

In the I²C Mode, the MCU can configure the internal relevant registers using I²C serial programming. The transmitter only supports the I²C format for byte write, page write, byte read and page read format. The transmission procedure is shown as below.

Symbol Definition

- S: Start symbol
- RS: Repeat Start
- P: Stop symbol
- DADDR[6:0]: device address, 21h
- R/W: read write select, R(0): write, (1): read
- RADDR[7:0]: register address
- ACK: A(0):ACK, NA(1):NAK
- Bus Direction:
 host to device:
 device to host:

Byte Write



Page Write



Byte Read



Page Read



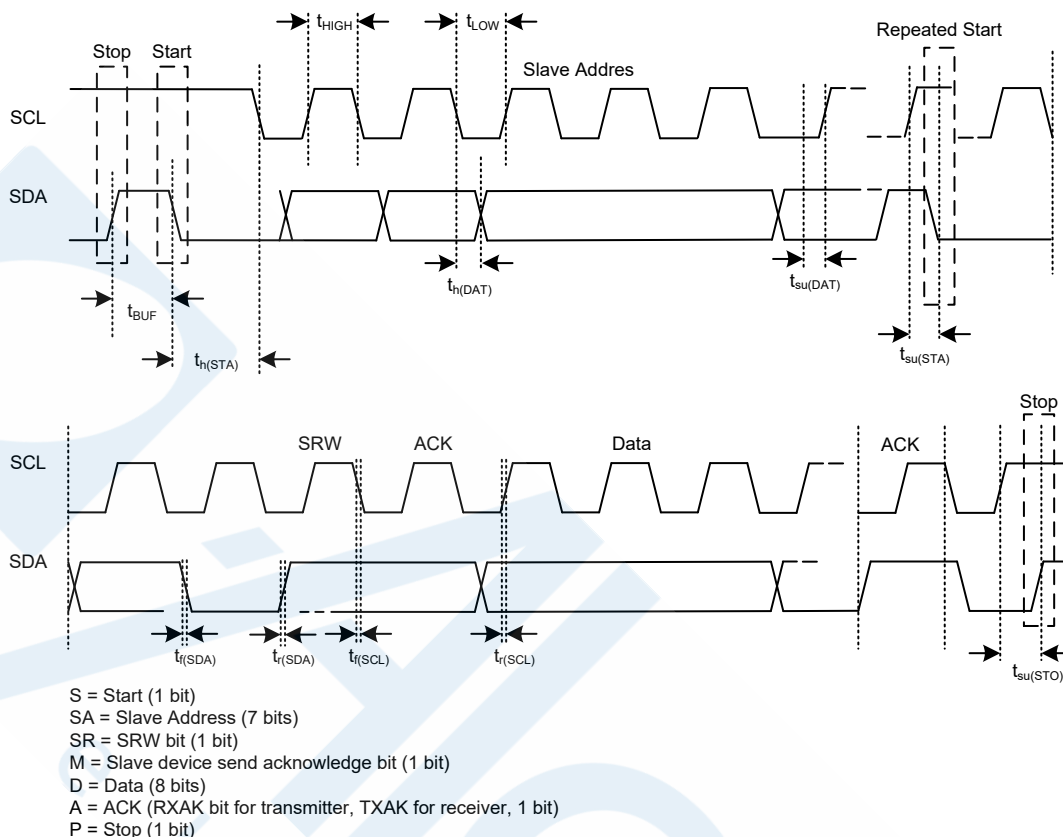

I²C Communication Timing Diagram

RF Transmitter Registers

When connected to an external MCU, the RF Transmitter can be setup and operated using a series of internal registers. The commands and data are written to and read from the RF Transmitter using its internal I²C bus. This list provides a summary of all internal registers. Their detailed operation is described under their relevant section in the functional description.

Address	Register Name	Bit							
		7	6	5	4	3	2	1	0
00h	CFG0	Setting0			XO_TRIM[5:0]				
01h	CFG1	DLY_TOFF[3:0]				Setting1			
02h	CFG2	FDEV[7:0]							
03h	CFG3	FSK_SEL	Setting2			TXPWR[3:0]			
04h	CFG4	D_N[5:0]					BAND_SEL[1:0]		
05h	CFG5	D_K[11:4]							
06h	CFG6	D_K[19:12]							
07h	CFG7	Setting3							

RF Transmitter Module Register Map

• **CFG0: Configuration Control Register 0**

Address	Bit	7	6	5	4	3	2	1	0
00h	Name	Setting0			XO_TRIM[5:0]				
	R/W	R/W	R/W	R/W					
	Initial Value	1	0	1	0	0	0	0	0

Bit 7~6 **Setting0**: Must be [0b10]

Bit 5~0 **XO_TRIM[5:0]**: Trim value of the internal capacitor array for different crystal C_{LOAD} Based on XO fabricated by YOKETAN corporation.

49US 16MHz XO w/ 16pF Cload: The default setting is 1B. Within ± 40 ppm frequency error, 1 trim code shift -2.88ppm.

3225SMD 16MHz XO w/ 16pF Cload: The default setting is 28. Within ± 20 ppm frequency error, 1 trim code shift -0.37ppm.

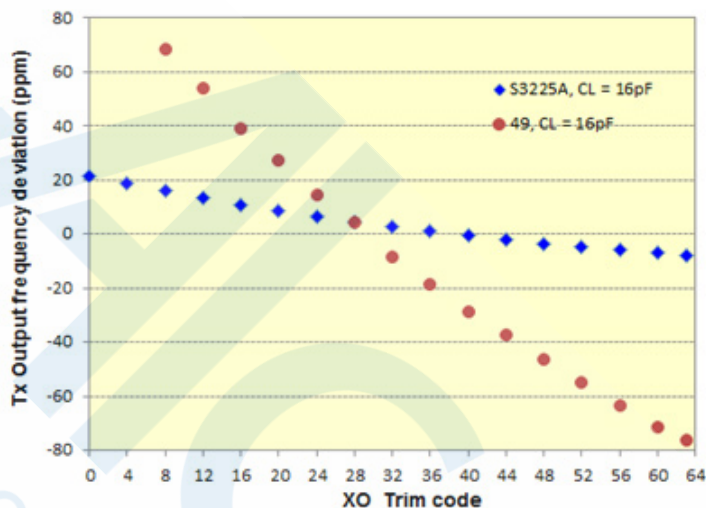

• **CFG1: Configuration Control Register 1**

Address	Bit	7	6	5	4	3	2	1	0	
01h	Name	DLY_TOFF[3:0]			Setting1					
	R/W	R/W			R/W					
	Initial Value	1	1	1	0	0	0	0	1	

Bit 7~4 **DLY_TOFF[3:0]**: Transmitter Auto Power Off Delay Time

$$t = 2\text{ms} \times (\text{DLY_TOFF}[3:0] + 2)$$

0000: 4ms

0001: 6ms

0010: 8ms

:

1110: 32ms

1111: Infinite – Never enter the Deep Sleep Mode

Bit 3~0 **Setting1**: Must be [0b0001]

• CFG2: Configuration Control Register 2

Address	Bit	7	6	5	4	3	2	1	0
02h	Name	FDEV[7:0]							
	R/W	R/W							
	Initial Value	0	1	1	0	0	1	1	0

Bit 7~0 **FDEV[7:0]**: Frequency deviation for FSK
 External Crystal = 16MHz, $FDEV = (f_{DEV} \times 2^{15} / f_{XTAL})$; $f_{XTAL} = 16\text{MHz}$
 Examples are as follows:
 Default FDEV[7:0] = 01100110 → Decimal 102
 External Crystal = 16MHz
 f_{DEV} (Frequency deviation) = $f_{DEV} \times (16\text{M} / 2^{15})$
 f_{DEV} (Frequency deviation) = $102 \times (16\text{M} / 32768) = 49.8\text{kHz}$

• CFG3: Configuration Control Register 3

Address	Bit	7	6	5	4	3	2	1	0
03h	Name	FSK_SEL	Setting2			TXPWR[3:0]			
	R/W	R/W	R/W			R/W			
	Initial Value	0	1	0	0	1	0	0	0

Bit 7 **FSK_SEL**: FSK Mode Enable
 0: OOK
 1: FSK

Bit 6~4 **Setting 2**: Must be [0b100]

Bit 3~0 **TXPWR[3:0]**: RF Output Power
 The device has several output power values which are 0, 5, 10, and 13dBm.

TXPWR[3:0]	RF Output Power	TXPWR[3:0]	RF Output Power Fine Tune Level
0000	0dBm	XX00	0
0100	5dBm	XX01	1
1000	10dBm	XX10	2
1100	13dBm	XX11	3

Note that the adjust range: Level 3 > Level 2 > Level 1 > Level 0.
 Note: Output power level could vary due to different matching components and placement on the PCB. The matching variation could significantly impact the output power level below +5dBm setting.

• CFG4: Configuration Control Register 4

Address	Bit	7	6	5	4	3	2	1	0
04h	Name	D_N[5:0]						BAND_SEL[1:0]	
	R/W	R/W						R/W	
	Initial Value	0	1	0	1	1	0	0	1

Bit 7~2 **D_N[5:0]**: Integer of dividend for MMD
 Bit 1~0 **BAND_SEL[1:0]**: Band Frequency Coarse Control

BAND_SEL	Frequency
00	315MHz
01	433MHz
10	868MHz
11	915MHz

Note that the BAND_SEL only select an approximate frequency range while the exact frequency value is determined by the D_N and D_K bit fields.

• **CFG5: Configuration Control Register 5**

Address	Bit	7	6	5	4	3	2	1	0
05h	Name	D_K[11:4]							
	R/W	R/W							
	Initial Value	0	1	1	1	0	0	0	0

• **CFG6: Configuration Control Register 6**

Address	Bit	7	6	5	4	3	2	1	0
06h	Name	D_K[19:12]							
	R/W	R/W							
	Initial Value	0	0	1	1	1	1	0	1

D_K[19:4]: 16-bit Fractional of dividend for MMD

D_N&D_K example.

X'TAL=16MHz and TX band =433MHz

1. D_N → (433M×Divider)/16M=54.125

Take the integer part → D_N=54-32=22 → 010110

2. D_K → (433M×Divider)/16M=54.125

Take the fractional part → D_K=0.125×2²⁰=131072 → 0010-0000-0000-0000

3. The example frequency can be referred in the following table.

Band_SEL	Frequency	Divider	X'TAL	D_N[5:0]	D_K[19:4]
315MHz	315MHz	2	16MHz	000111	0110-0000-0000-0000
433MHz	433MHz	2	16MHz	010110	0010-0000-0000-0000
433MHz	433.92MHz	2	16MHz	010110	0011-1101-0111-0000
868MHz	868MHz	1	16MHz	010110	0100-0000-0000-0000
915MHz	915MHz	1	16MHz	011001	0011-0000-0000-0000

• **CFG7: Configuration Control Register 7**

Address	Bit	7	6	5	4	3	2	1	0
07h	Name	Setting3							
	R/W	R/W							
	Initial Value	0	1	0	0	1	0	1	1

Bit 7~0 **Setting3:** Must be [0b1001011]

Interrupts

Interrupts are an important part of any microcontroller system. When an external event or an internal function such as a Timer Module or an A/D converter requires microcontroller attention, their corresponding interrupt will enforce a temporary suspension of the main program allowing the microcontroller to direct attention to their respective needs. The device contains several external interrupts and internal interrupts functions. The external interrupts are generated by the action of the external $\overline{\text{INT}}$ pin, while the internal interrupts are generated by various internal functions such as the TMs, Time Bases, EEPROM and the A/D converter.

Interrupt Registers

Overall interrupt control, which basically means the setting of request flags when certain microcontroller conditions occur and the setting of interrupt enable bits by the application program, is controlled by a series of registers, located in the Special Purpose Data Memory, as shown in the accompanying table. The number of registers depends upon the device chosen but fall into three categories. The first is the INTC0~INTC1 registers which setup the primary interrupts, the second is the MFI0~MFI1 registers which setup the Multi-function interrupts. Finally there is an INTEG register to setup the external interrupt trigger edge type.

Each register contains a number of enable bits to enable or disable individual registers as well as interrupt flags to indicate the presence of an interrupt request. The naming convention of these follows a specific pattern. First is listed an abbreviated interrupt type, then the (optional) number of that interrupt followed by either an “E” for enable/disable bit or “F” for request flag.

Function	Enable Bit	Request Flag	Notes
Global	EMI	—	—
INT Pin	INTE	INTF	—
A/D Converter	ADE	ADF	—
Multi-function	MFnE	MFnF	n=0 or 1
Time Bases	TBnE	TBnF	n=0 or 1
EEPROM	DEE	DEF	—
TM	STMA0E	STMA0F	—
	STMP0E	STMP0F	
	PTMA1E	PTMA1F	
	PTMP1E	PTMP1F	

Interrupt Register Bit Naming Conventions

Name	Bit7	Bit6	Bit5	Bit4	Bit3	Bit2	Bit1	Bit0
INTEG	—	—	—	—	—	—	INT0S1	INT0S0
INTC0	—	TB1F	TB0F	INTF	TB1E	TB0E	INTE	EMI
INTC1	MF1F	ADF	DEF	MF0F	MF1E	ADE	DEE	MF0E
MFI0	—	—	STMA0F	STMP0F	—	—	STMA0E	STMP0E
MFI1	—	—	PTMA1F	PTMP1F	—	—	PTMA1E	PTMP1E

Interrupt Register List

• **INTEG Register**

Bit	7	6	5	4	3	2	1	0
Name	—	—	—	—	—	—	INT0S1	INT0S0
R/W	—	—	—	—	—	—	R/W	R/W
POR	—	—	—	—	—	—	0	0

Bit 7~2 Unimplemented, read as “0”

Bit 1~0 **INT0S1~INT0S0**: Defines $\overline{\text{INT}}$ interrupt active edge
 00: Disable Interrupt
 01: Rising Edge Interrupt
 10: Falling Edge Interrupt
 11: Dual Edge Interrupt

• **INTC0 Register**

Bit	7	6	5	4	3	2	1	0
Name	—	TB1F	TB0F	INTF	TB1E	TB0E	INTE	EMI
R/W	—	R/W	R/W	R/W	R/W	R/W	R/W	R/W
POR	—	0	0	0	0	0	0	0

Bit 7 Unimplemented, read as “0”

Bit 6 **TB1F** : Time Base 1 Interrupt Request Flag
 0: No request
 1: Interrupt request

Bit 5 **TB0F**: Time Base 0 Interrupt Request Flag
 0: No request
 1: Interrupt request

Bit 4 **INTF**: $\overline{\text{INT}}$ Interrupt Request Flag
 0: No request
 1: Interrupt request

Bit 3 **TB1E** : Time Base 1 Interrupt Control
 0: Disable
 1: Enable

Bit 2 **TB0E**: Time Base 0 Interrupt Control
 0: Disable
 1: Enable

Bit 1 **INTE**: $\overline{\text{INT}}$ Interrupt Control
 0: Disable
 1: Enable

Bit 0 **EMI**: Global Interrupt Control
 0: Disable
 1: Enable

• INTC1 Register

Bit	7	6	5	4	3	2	1	0
Name	MF1F	ADF	DEF	MF0F	MF1E	ADE	DEE	MF0E
R/W	R/W	R/W	R/W	R/W	R/W	R/W	R/W	R/W
POR	0	0	0	0	0	0	0	0

Bit 7 **MF1F**: Multi-function 1 Interrupt Request Flag

0: No request
1: Interrupt request

Bit 6 **ADF**: A/D Converter Interrupt Request Flag

0: No request
1: Interrupt request

Bit 5 **DEF**: Data EEPROM Interrupt Request Flag

0: No request
1: Interrupt request

Bit 4 **MF0F**: Multi-function 0 Interrupt Request Flag

0: No request
1: Interrupt request

Bit 3 **MF1E**: Multi-function 1 Interrupt Control

0: Disable
1: Enable

Bit 2 **ADE**: A/D Converter Interrupt Control

0: Disable
1: Enable

Bit 1 **DEE**: Data EEPROM Interrupt Control

0: Disable
1: Enable

Bit 0 **MF0E**: Multi-function 0 Interrupt Control

0: Disable
1: Enable

• MFIO Register

Bit	7	6	5	4	3	2	1	0
Name	—	—	STMA0F	STMP0F	—	—	STMA0E	STMP0E
R/W	—	—	R/W	R/W	—	—	R/W	R/W
POR	—	—	0	0	—	—	0	0

Bit 7~6 Unimplemented, read as “0”

Bit 5 **STMA0F**: STM Comparator A match interrupt request flag

0: No request
1: Interrupt request

Bit 4 **STMP0F**: STM Comparator P match interrupt request flag

0: No request
1: Interrupt request

Bit 3~2 Unimplemented, read as “0”

Bit 1 **STMA0E**: STM Comparator A match interrupt control

0: Disable
1: Enable

Bit 0 **STMP0E**: STM Comparator P match interrupt control

0: Disable
1: Enable

• **MF1 Register**

Bit	7	6	5	4	3	2	1	0
Name	—	—	PTMA1F	PTMP1F	—	—	PTMA1E	PTMP1E
R/W	—	—	R/W	R/W	—	—	R/W	R/W
POR	—	—	0	0	—	—	0	0

- Bit 7~6 Unimplemented, read as “0”
- Bit 5 **PTMA1F**: PTM1 Comparator A match interrupt request flag
0: No request
1: Interrupt request
- Bit 4 **PTMP1F**: PTM1 Comparator P match interrupt request flag
0: No request
1: Interrupt request
- Bit 3~2 Unimplemented, read as “0”
- Bit 1 **PTMA1E**: PTM1 Comparator A match interrupt control
0: Disable
1: Enable
- Bit 0 **PTMP1E**: PTM1 Comparator P match interrupt control
0: Disable
1: Enable

Interrupt Operation

When the conditions for an interrupt event occur, such as a TM Comparator P or Comparator A match or A/D conversion completion etc, the relevant interrupt request flag will be set. Whether the request flag actually generates a program jump to the relevant interrupt vector is determined by the condition of the interrupt enable bit. If the enable bit is set high then the program will jump to its relevant vector; if the enable bit is zero then although the interrupt request flag is set an actual interrupt will not be generated and the program will not jump to the relevant interrupt vector. The global interrupt enable bit, if cleared to zero, will disable all interrupts.

When an interrupt is generated, the Program Counter, which stores the address of the next instruction to be executed, will be transferred onto the stack. The Program Counter will then be loaded with a new address which will be the value of the corresponding interrupt vector. The microcontroller will then fetch its next instruction from this interrupt vector. The instruction at this vector will usually be a “JMP” which will jump to another section of program which is known as the interrupt service routine. Here is located the code to control the appropriate interrupt. The interrupt service routine must be terminated with a “RETI”, which retrieves the original Program Counter address from the stack and allows the microcontroller to continue with normal execution at the point where the interrupt occurred.

The various interrupt enable bits, together with their associated request flags, are shown in the accompanying diagrams with their order of priority. Some interrupt sources have their own individual vector while others share the same multi-function interrupt vector. Once an interrupt subroutine is serviced, all the other interrupts will be blocked, as the global interrupt enable bit, EMI bit will be cleared automatically. This will prevent any further interrupt nesting from occurring. However, if other interrupt requests occur during this interval, although the interrupt will not be immediately serviced, the request flag will still be recorded.

If an interrupt requires immediate servicing while the program is already in another interrupt service routine, the EMI bit should be set after entering the routine, to allow interrupt nesting. If the stack is full, the interrupt request will not be acknowledged, even if the related interrupt is enabled, until the Stack Pointer is decremented. If immediate service is desired, the stack must be prevented from becoming full. In case of simultaneous requests, the accompanying diagram shows the priority that is applied. All of the interrupt request flags when set will wake-up the device if it is in SLEEP or IDLE Mode, however to prevent a wake-up from occurring the corresponding flag should be set before the device is in SLEEP or IDLE Mode.

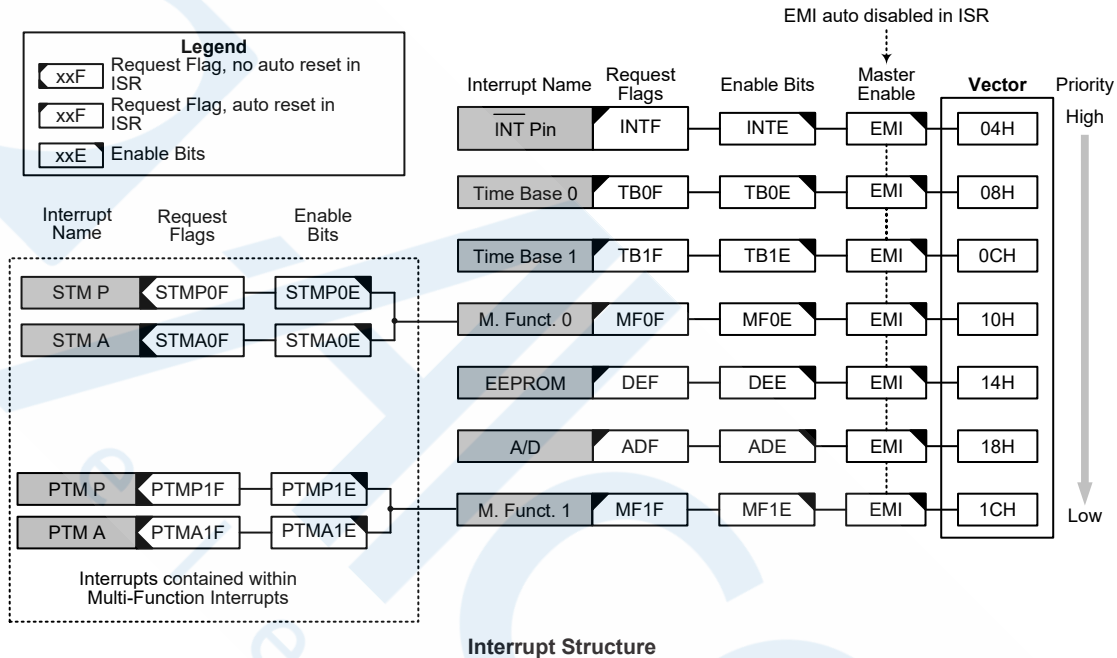

External Interrupts

The external interrupt is controlled by signal transitions on the pin \overline{INT} . An external interrupt request will take place when the external interrupt request flag, INTF, is set, which will occur when a transition, whose type is chosen by the edge select bits, appears on the external interrupt pin. To allow the program to branch to the interrupt vector address, the global interrupt enable bit, EMI, and the external interrupt enable bit, INTE, must first be set. Additionally the correct interrupt edge type must be selected using the INTEG register to enable the external interrupt function and to choose the trigger edge type. As the external interrupt pins are pin-shared with I/O pins, they can only be configured as external interrupt pins by setting the relevant pin-shared registers. The pin must also be setup as an input by setting the corresponding bit in the port control register. When the interrupt is enabled, the stack is not full and the correct transition type appears on the external interrupt pin, a subroutine call to the external interrupt vector, will take place. When the interrupt is serviced, the external interrupt request flag, INTF, will be automatically reset and the EMI bit will be automatically cleared to disable other interrupts. Note that the pull-high resistor selection on the external interrupt pin will remain valid even if the pin is used as an external interrupt input.

The INTEG register is used to select the type of active edge that will trigger the external interrupt. A choice of either rising or falling or both edge types can be chosen to trigger an external interrupt. Note that the INTEG register can also be used to disable the external interrupt function.

Multi-function Interrupts

Within this device there are two Multi-function interrupts. Unlike the other independent interrupts, these interrupts have no independent source, but rather are formed from other existing interrupt sources, namely the TM Interrupts.

A Multi-function interrupt request will take place when any of the Multi-function interrupt request flags, MF0F~MF1F are set. The Multi-function interrupt flags will be set when any of their included functions generate an interrupt request flag. To allow the program to branch to its respective interrupt vector address, when the Multi-function interrupt is enabled and the stack is not full, and either one of the interrupts contained within each of Multi-function interrupt occurs, a subroutine call to one of the Multi-function interrupt vectors will take place. When the interrupt is serviced, the related Multi-Function request flag, will be automatically reset and the EMI bit will be automatically cleared to disable other interrupts.

However, it must be noted that, although the Multi-function Interrupt flags will be automatically reset when the interrupt is serviced, the request flags from the original source of the Multi-function interrupts, namely the TM Interrupts, will not be automatically reset and must be manually reset by the application program.

A/D Converter Interrupt

The device contains an A/D converter which has its own independent interrupt. The A/D Converter Interrupt is controlled by the termination of an A/D conversion process. An A/D Converter Interrupt request will take place when the A/D Converter Interrupt request flag, ADF, is set, which occurs when the A/D conversion process finishes. To allow the program to branch to its interrupt vector address, the global interrupt enable bit, EMI, and A/D Interrupt enable bit, ADE, must first be set. When the interrupt is enabled, the stack is not full and the A/D conversion process has ended, a subroutine call to the A/D Converter Interrupt vector, will take place. When the interrupt is serviced, the A/D Converter Interrupt flag, ADF, will be automatically cleared. The EMI bit will also be automatically cleared to disable other interrupts.

Time Base Interrupts

The function of the Time Base Interrupts is to provide regular time signal in the form of an internal interrupt. They are controlled by the overflow signals from their respective timer functions. When these happens their respective interrupt request flags, TB0F or TB1F will be set. To allow the program to branch to their respective interrupt vector addresses, the global interrupt enable bit, EMI and Time Base enable bits, TB0E or TB1E, must first be set. When the interrupt is enabled, the stack is not full and the Time Base overflows, a subroutine call to their respective vector locations will take place. When the interrupt is serviced, the respective interrupt request flag, TB0F or TB1F, will be automatically reset and the EMI bit will be cleared to disable other interrupts.

The purpose of the Time Base Interrupt is to provide an interrupt signal at fixed time periods. Their clock sources originate from the internal clock source f_{TB} . This f_{TB} input clock passes through a divider, the division ratio of which is selected by programming the appropriate bits in the TBC register to obtain longer interrupt periods whose value ranges. The clock source that generates f_{TB} , which in turn controls the Time Base interrupt period is selected using the TBCK bit in the TBC register.

• TBC Register

Bit	7	6	5	4	3	2	1	0
Name	TBON	TBCK	TB11	TB10	—	TB02	TB01	TB00
R/W	R/W	R/W	R/W	R/W	—	R/W	R/W	R/W
POR	0	0	1	1	—	1	1	1

- Bit 7 **TBON**: TB0 and TB1 Control bit
0: Disable
1: Enable
- Bit 6 **TBCK**: Select f_{TB} Clock
0: f_{TBC}
1: $f_{SYS}/4$
- Bit 5~4 **TB11~TB10**: Select Time Base 1 Time-out Period
00: $4096/f_{TB}$
01: $8192/f_{TB}$
10: $16384/f_{TB}$
11: $32768/f_{TB}$
- Bit 3 Unimplemented, read as “0”
- Bit 2~0 **TB02~TB00**: Select Time Base 0 Time-out Period
000: $256/f_{TB}$
001: $512/f_{TB}$
010: $1024/f_{TB}$
011: $2048/f_{TB}$
100: $4096/f_{TB}$
101: $8192/f_{TB}$
110: $16384/f_{TB}$
111: $32768/f_{TB}$

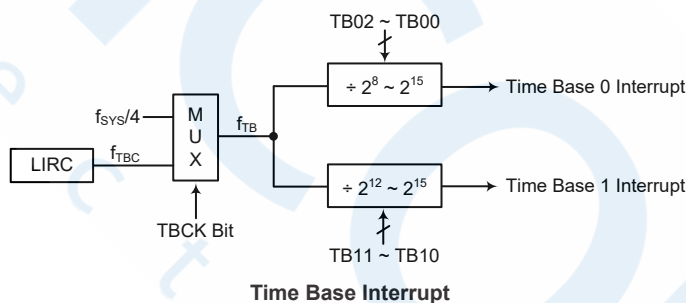

EEPROM Interrupt

An EEPROM Interrupt request will take place when the EEPROM Interrupt request flag, DEF, is set, which occurs when an EEPROM Write cycle ends. To allow the program to branch to its respective interrupt vector address, the global interrupt enable bit, EMI, and EEPROM Interrupt enable bit, DEE, must first be set. When the interrupt is enabled, the stack is not full and an EEPROM Write cycle ends, a subroutine call to the EEPROM Interrupt vector, will take place. When the EEPROM Interrupt is serviced, the EMI bit will be automatically cleared to disable other interrupts, and the EEPROM interrupt request flag, DEF, will also be automatically cleared.

TM Interrupts

The TMs each has two interrupts. All of the TM interrupts are contained within the Multi-function Interrupts. For each of the TMs there are two interrupt request flags xTMPnF and xTMAnF and two enable bits xTMPnE and xTMAnE. A TM interrupt request will take place when any of the

TM request flags are set, a situation which occurs when a TM comparator P or comparator A match situation happens.

To allow the program to branch to its respective interrupt vector address, the global interrupt enable bit, EMI, and the respective TM Interrupt enable bit, and associated Multi-function interrupt enable bit, MFnF, must first be set. When the interrupt is enabled, the stack is not full and a TM comparator match situation occurs, a subroutine call to the relevant TM Interrupt vector locations, will take place. When the TM interrupt is serviced, the EMI bit will be automatically cleared to disable other interrupts, however only the related MFnF flag will be automatically cleared. As the TM interrupt request flags will not be automatically cleared, they have to be cleared by the application program.

Interrupt Wake-up Function

Each of the interrupt functions has the capability of waking up the microcontroller when in the SLEEP or IDLE Mode. A wake-up is generated when an interrupt request flag changes from low to high and is independent of whether the interrupt is enabled or not. Therefore, even though the device is in the SLEEP or IDLE Mode and its system oscillator stopped, situations such as external edge transitions on the external interrupt pin may cause their respective interrupt flag to be set high and consequently generate an interrupt. Care must therefore be taken if spurious wake-up situations are to be avoided. If an interrupt wake-up function is to be disabled then the corresponding interrupt request flag should be set high before the device enters the SLEEP or IDLE Mode. The interrupt enable bits have no effect on the interrupt wake-up function.

Programming Considerations

By disabling the relevant interrupt enable bits, a requested interrupt can be prevented from being serviced, however, once an interrupt request flag is set, it will remain in this condition in the interrupt register until the corresponding interrupt is serviced or until the request flag is cleared by the application program.

Where a certain interrupt is contained within a Multi-function interrupt, then when the interrupt service routine is executed, as only the Multi-function interrupt request flags, MF0F~MF1F, will be automatically cleared, the individual request flag for the function needs to be cleared by the application program.

It is recommended that programs do not use the “CALL” instruction within the interrupt service subroutine. Interrupts often occur in an unpredictable manner or need to be serviced immediately. If only one stack is left and the interrupt is not well controlled, the original control sequence will be damaged once a CALL subroutine is executed in the interrupt subroutine.

Every interrupt has the capability of waking up the microcontroller when it is in SLEEP or IDLE Mode, the wake up being generated when the interrupt request flag changes from low to high. If it is required to prevent a certain interrupt from waking up the microcontroller then its respective request flag should be first set high before enter SLEEP or IDLE Mode.

As only the Program Counter is pushed onto the stack, then when the interrupt is serviced, if the contents of the accumulator, status register or other registers are altered by the interrupt service program, their contents should be saved to the memory at the beginning of the interrupt service routine.

To return from an interrupt subroutine, either a RET or RETI instruction may be executed. The RETI instruction in addition to executing a return to the main program also automatically sets the EMI bit high to allow further interrupts. The RET instruction however only executes a return to the main program leaving the EMI bit in its present zero state and therefore disabling the execution of further interrupts.

Application Circuits

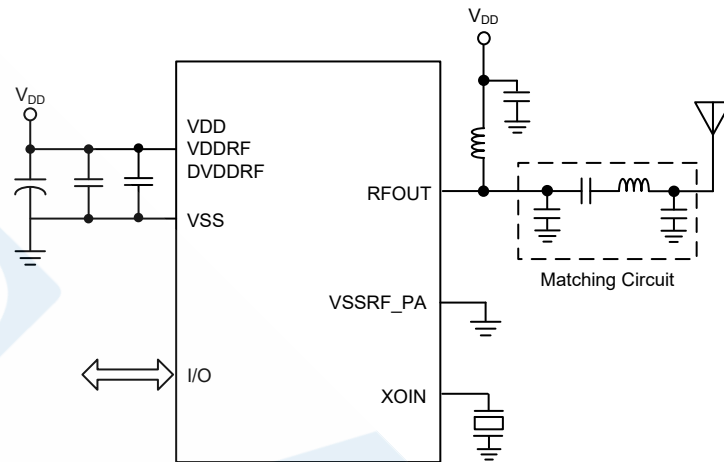

Note: "*" Recommended component for added ESD protection.

"**" Recommended component in environments where power line noise is significant.

Instruction Set

Introduction

Central to the successful operation of any microcontroller is its instruction set, which is a set of program instruction codes that directs the microcontroller to perform certain operations. In the case of Holtek microcontroller, a comprehensive and flexible set of over 60 instructions is provided to enable programmers to implement their application with the minimum of programming overheads.

For easier understanding of the various instruction codes, they have been subdivided into several functional groupings.

Instruction Timing

Most instructions are implemented within one instruction cycle. The exceptions to this are branch, call, or table read instructions where two instruction cycles are required. One instruction cycle is equal to 4 system clock cycles, therefore in the case of an 8MHz system oscillator, most instructions would be implemented within 0.5 μ s and branch or call instructions would be implemented within 1 μ s. Although instructions which require one more cycle to implement are generally limited to the JMP, CALL, RET, RETI and table read instructions, it is important to realize that any other instructions which involve manipulation of the Program Counter Low register or PCL will also take one more cycle to implement. As instructions which change the contents of the PCL will imply a direct jump to that new address, one more cycle will be required. Examples of such instructions would be "CLR PCL" or "MOV PCL, A". For the case of skip instructions, it must be noted that if the result of the comparison involves a skip operation then this will also take one more cycle, if no skip is involved then only one cycle is required.

Moving and Transferring Data

The transfer of data within the microcontroller program is one of the most frequently used operations. Making use of three kinds of MOV instructions, data can be transferred from registers to the Accumulator and vice-versa as well as being able to move specific immediate data directly into the Accumulator. One of the most important data transfer applications is to receive data from the input ports and transfer data to the output ports.

Arithmetic Operations

The ability to perform certain arithmetic operations and data manipulation is a necessary feature of most microcontroller applications. Within the Holtek microcontroller instruction set are a range of add and subtract instruction mnemonics to enable the necessary arithmetic to be carried out. Care must be taken to ensure correct handling of carry and borrow data when results exceed 255 for addition and less than 0 for subtraction. The increment and decrement instructions INC, INCA, DEC and DECA provide a simple means of increasing or decreasing by a value of one of the values in the destination specified.

Logical and Rotate Operation

The standard logical operations such as AND, OR, XOR and CPL all have their own instruction within the Holtek microcontroller instruction set. As with the case of most instructions involving data manipulation, data must pass through the Accumulator which may involve additional programming steps. In all logical data operations, the zero flag may be set if the result of the operation is zero. Another form of logical data manipulation comes from the rotate instructions such as RR, RL, RRC and RLC which provide a simple means of rotating one bit right or left. Different rotate instructions exist depending on program requirements. Rotate instructions are useful for serial port programming applications where data can be rotated from an internal register into the Carry bit from where it can be examined and the necessary serial bit set high or low. Another application which rotate data operations are used is to implement multiplication and division calculations.

Branches and Control Transfer

Program branching takes the form of either jumps to specified locations using the JMP instruction or to a subroutine using the CALL instruction. They differ in the sense that in the case of a subroutine call, the program must return to the instruction immediately when the subroutine has been carried out. This is done by placing a return instruction "RET" in the subroutine which will cause the program to jump back to the address right after the CALL instruction. In the case of a JMP instruction, the program simply jumps to the desired location. There is no requirement to jump back to the original jumping off point as in the case of the CALL instruction. One special and extremely useful set of branch instructions are the conditional branches. Here a decision is first made regarding the condition of a certain data memory or individual bits. Depending upon the conditions, the program will continue with the next instruction or skip over it and jump to the following instruction. These instructions are the key to decision making and branching within the program perhaps determined by the condition of certain input switches or by the condition of internal data bits.

Bit Operations

The ability to provide single bit operations on Data Memory is an extremely flexible feature of all Holtek microcontrollers. This feature is especially useful for output port bit programming where individual bits or port pins can be directly set high or low using either the "SET [m].i" or "CLR [m].i" instructions respectively. The feature removes the need for programmers to first read the 8-bit output port, manipulate the input data to ensure that other bits are not changed and then output the port with the correct new data. This read-modify-write process is taken care of automatically when these bit operation instructions are used.

Table Read Operations

Data storage is normally implemented by using registers. However, when working with large amounts of fixed data, the volume involved often makes it inconvenient to store the fixed data in the Data Memory. To overcome this problem, Holtek microcontrollers allow an area of Program Memory to be set as a table where data can be directly stored. A set of easy to use instructions provides the means by which this fixed data can be referenced and retrieved from the Program Memory.

Other Operations

In addition to the above functional instructions, a range of other instructions also exist such as the "HALT" instruction for Power-down operations and instructions to control the operation of the Watchdog Timer for reliable program operations under extreme electric or electromagnetic environments. For their relevant operations, refer to the functional related sections.

Instruction Set Summary

The following table depicts a summary of the instruction set categorised according to function and can be consulted as a basic instruction reference using the following listed conventions.

Table Conventions

x: Bits immediate data
 m: Data Memory address
 A: Accumulator
 i: 0~7 number of bits
 addr: Program memory address

Mnemonic	Description	Cycles	Flag Affected
Arithmetic			
ADD A,[m]	Add Data Memory to ACC	1	Z, C, AC, OV
ADDM A,[m]	Add ACC to Data Memory	1 ^{Note}	Z, C, AC, OV
ADD A,x	Add immediate data to ACC	1	Z, C, AC, OV
ADC A,[m]	Add Data Memory to ACC with Carry	1	Z, C, AC, OV
ADCM A,[m]	Add ACC to Data memory with Carry	1 ^{Note}	Z, C, AC, OV
SUB A,x	Subtract immediate data from the ACC	1	Z, C, AC, OV
SUB A,[m]	Subtract Data Memory from ACC	1	Z, C, AC, OV
SUBM A,[m]	Subtract Data Memory from ACC with result in Data Memory	1 ^{Note}	Z, C, AC, OV
SBC A,[m]	Subtract Data Memory from ACC with Carry	1	Z, C, AC, OV
SBCM A,[m]	Subtract Data Memory from ACC with Carry, result in Data Memory	1 ^{Note}	Z, C, AC, OV
DAA [m]	Decimal adjust ACC for Addition with result in Data Memory	1 ^{Note}	C
Logic Operation			
AND A,[m]	Logical AND Data Memory to ACC	1	Z
OR A,[m]	Logical OR Data Memory to ACC	1	Z
XOR A,[m]	Logical XOR Data Memory to ACC	1	Z
ANDM A,[m]	Logical AND ACC to Data Memory	1 ^{Note}	Z
ORM A,[m]	Logical OR ACC to Data Memory	1 ^{Note}	Z
XORM A,[m]	Logical XOR ACC to Data Memory	1 ^{Note}	Z
AND A,x	Logical AND immediate Data to ACC	1	Z
OR A,x	Logical OR immediate Data to ACC	1	Z
XOR A,x	Logical XOR immediate Data to ACC	1	Z
CPL [m]	Complement Data Memory	1 ^{Note}	Z
CPLA [m]	Complement Data Memory with result in ACC	1	Z
Increment & Decrement			
INCA [m]	Increment Data Memory with result in ACC	1	Z
INC [m]	Increment Data Memory	1 ^{Note}	Z
DECA [m]	Decrement Data Memory with result in ACC	1	Z
DEC [m]	Decrement Data Memory	1 ^{Note}	Z
Rotate			
RRA [m]	Rotate Data Memory right with result in ACC	1	None
RR [m]	Rotate Data Memory right	1 ^{Note}	None
RRCA [m]	Rotate Data Memory right through Carry with result in ACC	1	C
RRC [m]	Rotate Data Memory right through Carry	1 ^{Note}	C
RLA [m]	Rotate Data Memory left with result in ACC	1	None
RL [m]	Rotate Data Memory left	1 ^{Note}	None
RLCA [m]	Rotate Data Memory left through Carry with result in ACC	1	C
RLC [m]	Rotate Data Memory left through Carry	1 ^{Note}	C

Mnemonic	Description	Cycles	Flag Affected
Data Move			
MOV A,[m]	Move Data Memory to ACC	1	None
MOV [m],A	Move ACC to Data Memory	1 ^{Note}	None
MOV A,x	Move immediate data to ACC	1	None
Bit Operation			
CLR [m].i	Clear bit of Data Memory	1 ^{Note}	None
SET [m].i	Set bit of Data Memory	1 ^{Note}	None
Branch Operation			
JMP addr	Jump unconditionally	2	None
SZ [m]	Skip if Data Memory is zero	1 ^{Note}	None
SZA [m]	Skip if Data Memory is zero with data movement to ACC	1 ^{Note}	None
SZ [m].i	Skip if bit i of Data Memory is zero	1 ^{Note}	None
SNZ [m].i	Skip if bit i of Data Memory is not zero	1 ^{Note}	None
SIZ [m]	Skip if increment Data Memory is zero	1 ^{Note}	None
SDZ [m]	Skip if decrement Data Memory is zero	1 ^{Note}	None
SIZA [m]	Skip if increment Data Memory is zero with result in ACC	1 ^{Note}	None
SDZA [m]	Skip if decrement Data Memory is zero with result in ACC	1 ^{Note}	None
CALL addr	Subroutine call	2	None
RET	Return from subroutine	2	None
RET A,x	Return from subroutine and load immediate data to ACC	2	None
RETI	Return from interrupt	2	None
Table Read Operation			
TABRD [m]	Read table (specific page or current page) to TBLH and Data Memory	2 ^{Note}	None
TABRDL [m]	Read table (last page) to TBLH and Data Memory	2 ^{Note}	None
Miscellaneous			
NOP	No operation	1	None
CLR [m]	Clear Data Memory	1 ^{Note}	None
SET [m]	Set Data Memory	1 ^{Note}	None
CLR WDT	Clear Watchdog Timer	1	TO, PDF
SWAP [m]	Swap nibbles of Data Memory	1 ^{Note}	None
SWAPA [m]	Swap nibbles of Data Memory with result in ACC	1	None
HALT	Enter power down mode	1	TO, PDF

Note: 1. For skip instructions, if the result of the comparison involves a skip then two cycles are required, if no skip takes place only one cycle is required.

2. Any instruction which changes the contents of the PCL will also require 2 cycles for execution.

Instruction Definition

ADC A,[m]	Add Data Memory to ACC with Carry
Description	The contents of the specified Data Memory, Accumulator and the carry flag are added. The result is stored in the Accumulator.
Operation	$ACC \leftarrow ACC + [m] + C$
Affected flag(s)	OV, Z, AC, C
ADCM A,[m]	Add ACC to Data Memory with Carry
Description	The contents of the specified Data Memory, Accumulator and the carry flag are added. The result is stored in the specified Data Memory.
Operation	$[m] \leftarrow ACC + [m] + C$
Affected flag(s)	OV, Z, AC, C
ADD A,[m]	Add Data Memory to ACC
Description	The contents of the specified Data Memory and the Accumulator are added. The result is stored in the Accumulator.
Operation	$ACC \leftarrow ACC + [m]$
Affected flag(s)	OV, Z, AC, C
ADD A,x	Add immediate data to ACC
Description	The contents of the Accumulator and the specified immediate data are added. The result is stored in the Accumulator.
Operation	$ACC \leftarrow ACC + x$
Affected flag(s)	OV, Z, AC, C
ADDM A,[m]	Add ACC to Data Memory
Description	The contents of the specified Data Memory and the Accumulator are added. The result is stored in the specified Data Memory.
Operation	$[m] \leftarrow ACC + [m]$
Affected flag(s)	OV, Z, AC, C
AND A,[m]	Logical AND Data Memory to ACC
Description	Data in the Accumulator and the specified Data Memory perform a bitwise logical AND operation. The result is stored in the Accumulator.
Operation	$ACC \leftarrow ACC \text{ "AND" } [m]$
Affected flag(s)	Z
AND A,x	Logical AND immediate data to ACC
Description	Data in the Accumulator and the specified immediate data perform a bit wise logical AND operation. The result is stored in the Accumulator.
Operation	$ACC \leftarrow ACC \text{ "AND" } x$
Affected flag(s)	Z
ANDM A,[m]	Logical AND ACC to Data Memory
Description	Data in the specified Data Memory and the Accumulator perform a bitwise logical AND operation. The result is stored in the Data Memory.
Operation	$[m] \leftarrow ACC \text{ "AND" } [m]$
Affected flag(s)	Z

CALL addr	Subroutine call
Description	Unconditionally calls a subroutine at the specified address. The Program Counter then increments by 1 to obtain the address of the next instruction which is then pushed onto the stack. The specified address is then loaded and the program continues execution from this new address. As this instruction requires an additional operation, it is a two cycle instruction.
Operation	Stack \leftarrow Program Counter + 1 Program Counter \leftarrow addr
Affected flag(s)	None
CLR [m]	Clear Data Memory
Description	Each bit of the specified Data Memory is cleared to 0.
Operation	[m] \leftarrow 00H
Affected flag(s)	None
CLR [m].i	Clear bit of Data Memory
Description	Bit i of the specified Data Memory is cleared to 0.
Operation	[m].i \leftarrow 0
Affected flag(s)	None
CLR WDT	Clear Watchdog Timer
Description	The TO, PDF flags and the WDT are all cleared.
Operation	WDT cleared TO \leftarrow 0 PDF \leftarrow 0
Affected flag(s)	TO, PDF
CPL [m]	Complement Data Memory
Description	Each bit of the specified Data Memory is logically complemented (1's complement). Bits which previously contained a 1 are changed to 0 and vice versa.
Operation	[m] \leftarrow $\overline{[m]}$
Affected flag(s)	Z
CPLA [m]	Complement Data Memory with result in ACC
Description	Each bit of the specified Data Memory is logically complemented (1's complement). Bits which previously contained a 1 are changed to 0 and vice versa. The complemented result is stored in the Accumulator and the contents of the Data Memory remain unchanged.
Operation	ACC \leftarrow $\overline{[m]}$
Affected flag(s)	Z
DAA [m]	Decimal-Adjust ACC for addition with result in Data Memory
Description	Convert the contents of the Accumulator value to a BCD (Binary Coded Decimal) value resulting from the previous addition of two BCD variables. If the low nibble is greater than 9 or if AC flag is set, then a value of 6 will be added to the low nibble. Otherwise the low nibble remains unchanged. If the high nibble is greater than 9 or if the C flag is set, then a value of 6 will be added to the high nibble. Essentially, the decimal conversion is performed by adding 00H, 06H, 60H or 66H depending on the Accumulator and flag conditions. Only the C flag may be affected by this instruction which indicates that if the original BCD sum is greater than 100, it allows multiple precision decimal addition.
Operation	[m] \leftarrow ACC + 00H or [m] \leftarrow ACC + 06H or [m] \leftarrow ACC + 60H or [m] \leftarrow ACC + 66H
Affected flag(s)	C

DEC [m]	Decrement Data Memory
Description	Data in the specified Data Memory is decremented by 1.
Operation	$[m] \leftarrow [m] - 1$
Affected flag(s)	Z
DECA [m]	Decrement Data Memory with result in ACC
Description	Data in the specified Data Memory is decremented by 1. The result is stored in the Accumulator. The contents of the Data Memory remain unchanged.
Operation	$ACC \leftarrow [m] - 1$
Affected flag(s)	Z
HALT	Enter power down mode
Description	This instruction stops the program execution and turns off the system clock. The contents of the Data Memory and registers are retained. The WDT and prescaler are cleared. The power down flag PDF is set and the WDT time-out flag TO is cleared.
Operation	$TO \leftarrow 0$ $PDF \leftarrow 1$
Affected flag(s)	TO, PDF
INC [m]	Increment Data Memory
Description	Data in the specified Data Memory is incremented by 1.
Operation	$[m] \leftarrow [m] + 1$
Affected flag(s)	Z
INCA [m]	Increment Data Memory with result in ACC
Description	Data in the specified Data Memory is incremented by 1. The result is stored in the Accumulator. The contents of the Data Memory remain unchanged.
Operation	$ACC \leftarrow [m] + 1$
Affected flag(s)	Z
JMP addr	Jump unconditionally
Description	The contents of the Program Counter are replaced with the specified address. Program execution then continues from this new address. As this requires the insertion of a dummy instruction while the new address is loaded, it is a two cycle instruction.
Operation	Program Counter \leftarrow addr
Affected flag(s)	None
MOV A,[m]	Move Data Memory to ACC
Description	The contents of the specified Data Memory are copied to the Accumulator.
Operation	$ACC \leftarrow [m]$
Affected flag(s)	None
MOV A,x	Move immediate data to ACC
Description	The immediate data specified is loaded into the Accumulator.
Operation	$ACC \leftarrow x$
Affected flag(s)	None
MOV [m],A	Move ACC to Data Memory
Description	The contents of the Accumulator are copied to the specified Data Memory.
Operation	$[m] \leftarrow ACC$
Affected flag(s)	None

NOP	No operation
Description	No operation is performed. Execution continues with the next instruction.
Operation	No operation
Affected flag(s)	None
OR A,[m]	Logical OR Data Memory to ACC
Description	Data in the Accumulator and the specified Data Memory perform a bitwise logical OR operation. The result is stored in the Accumulator.
Operation	ACC ← ACC "OR" [m]
Affected flag(s)	Z
OR A,x	Logical OR immediate data to ACC
Description	Data in the Accumulator and the specified immediate data perform a bitwise logical OR operation. The result is stored in the Accumulator.
Operation	ACC ← ACC "OR" x
Affected flag(s)	Z
ORM A,[m]	Logical OR ACC to Data Memory
Description	Data in the specified Data Memory and the Accumulator perform a bitwise logical OR operation. The result is stored in the Data Memory.
Operation	[m] ← ACC "OR" [m]
Affected flag(s)	Z
RET	Return from subroutine
Description	The Program Counter is restored from the stack. Program execution continues at the restored address.
Operation	Program Counter ← Stack
Affected flag(s)	None
RET A,x	Return from subroutine and load immediate data to ACC
Description	The Program Counter is restored from the stack and the Accumulator loaded with the specified immediate data. Program execution continues at the restored address.
Operation	Program Counter ← Stack ACC ← x
Affected flag(s)	None
RETI	Return from interrupt
Description	The Program Counter is restored from the stack and the interrupts are re-enabled by setting the EMI bit. EMI is the master interrupt global enable bit. If an interrupt was pending when the RETI instruction is executed, the pending Interrupt routine will be processed before returning to the main program.
Operation	Program Counter ← Stack EMI ← 1
Affected flag(s)	None
RL [m]	Rotate Data Memory left
Description	The contents of the specified Data Memory are rotated left by 1 bit with bit 7 rotated into bit 0.
Operation	[m].(i+1) ← [m].i; (i=0~6) [m].0 ← [m].7
Affected flag(s)	None

RLA [m]	Rotate Data Memory left with result in ACC
Description	The contents of the specified Data Memory are rotated left by 1 bit with bit 7 rotated into bit 0. The rotated result is stored in the Accumulator and the contents of the Data Memory remain unchanged.
Operation	ACC.(i+1) ← [m].i; (i=0~6) ACC.0 ← [m].7
Affected flag(s)	None
RLC [m]	Rotate Data Memory left through Carry
Description	The contents of the specified Data Memory and the carry flag are rotated left by 1 bit. Bit 7 replaces the Carry bit and the original carry flag is rotated into bit 0.
Operation	[m].(i+1) ← [m].i; (i=0~6) [m].0 ← C C ← [m].7
Affected flag(s)	C
RLCA [m]	Rotate Data Memory left through Carry with result in ACC
Description	Data in the specified Data Memory and the carry flag are rotated left by 1 bit. Bit 7 replaces the Carry bit and the original carry flag is rotated into the bit 0. The rotated result is stored in the Accumulator and the contents of the Data Memory remain unchanged.
Operation	ACC.(i+1) ← [m].i; (i=0~6) ACC.0 ← C C ← [m].7
Affected flag(s)	C
RR [m]	Rotate Data Memory right
Description	The contents of the specified Data Memory are rotated right by 1 bit with bit 0 rotated into bit 7.
Operation	[m].i ← [m].(i+1); (i=0~6) [m].7 ← [m].0
Affected flag(s)	None
RRA [m]	Rotate Data Memory right with result in ACC
Description	Data in the specified Data Memory is rotated right by 1 bit with bit 0 rotated into bit 7. The rotated result is stored in the Accumulator and the contents of the Data Memory remain unchanged.
Operation	ACC.i ← [m].(i+1); (i=0~6) ACC.7 ← [m].0
Affected flag(s)	None
RRC [m]	Rotate Data Memory right through Carry
Description	The contents of the specified Data Memory and the carry flag are rotated right by 1 bit. Bit 0 replaces the Carry bit and the original carry flag is rotated into bit 7.
Operation	[m].i ← [m].(i+1); (i=0~6) [m].7 ← C C ← [m].0
Affected flag(s)	C

RRCA [m]	Rotate Data Memory right through Carry with result in ACC
Description	Data in the specified Data Memory and the carry flag are rotated right by 1 bit. Bit 0 replaces the Carry bit and the original carry flag is rotated into bit 7. The rotated result is stored in the Accumulator and the contents of the Data Memory remain unchanged.
Operation	ACC.i ← [m].(i+1); (i=0~6) ACC.7 ← C C ← [m].0
Affected flag(s)	C
SBC A,[m]	Subtract Data Memory from ACC with Carry
Description	The contents of the specified Data Memory and the complement of the carry flag are subtracted from the Accumulator. The result is stored in the Accumulator. Note that if the result of subtraction is negative, the C flag will be cleared to 0, otherwise if the result is positive or zero, the C flag will be set to 1.
Operation	ACC ← ACC – [m] – \bar{C}
Affected flag(s)	OV, Z, AC, C
SBCM A,[m]	Subtract Data Memory from ACC with Carry and result in Data Memory
Description	The contents of the specified Data Memory and the complement of the carry flag are subtracted from the Accumulator. The result is stored in the Data Memory. Note that if the result of subtraction is negative, the C flag will be cleared to 0, otherwise if the result is positive or zero, the C flag will be set to 1.
Operation	[m] ← ACC – [m] – \bar{C}
Affected flag(s)	OV, Z, AC, C
SDZ [m]	Skip if decrement Data Memory is 0
Description	The contents of the specified Data Memory are first decremented by 1. If the result is 0 the following instruction is skipped. As this requires the insertion of a dummy instruction while the next instruction is fetched, it is a two cycle instruction. If the result is not 0 the program proceeds with the following instruction.
Operation	[m] ← [m] – 1 Skip if [m]=0
Affected flag(s)	None
SDZA [m]	Skip if decrement Data Memory is zero with result in ACC
Description	The contents of the specified Data Memory are first decremented by 1. If the result is 0, the following instruction is skipped. The result is stored in the Accumulator but the specified Data Memory contents remain unchanged. As this requires the insertion of a dummy instruction while the next instruction is fetched, it is a two cycle instruction. If the result is not 0, the program proceeds with the following instruction.
Operation	ACC ← [m] – 1 Skip if ACC=0
Affected flag(s)	None
SET [m]	Set Data Memory
Description	Each bit of the specified Data Memory is set to 1.
Operation	[m] ← FFH
Affected flag(s)	None
SET [m].i	Set bit of Data Memory
Description	Bit i of the specified Data Memory is set to 1.
Operation	[m].i ← 1
Affected flag(s)	None

SIZ [m]	Skip if increment Data Memory is 0
Description	The contents of the specified Data Memory are first incremented by 1. If the result is 0, the following instruction is skipped. As this requires the insertion of a dummy instruction while the next instruction is fetched, it is a two cycle instruction. If the result is not 0 the program proceeds with the following instruction.
Operation	$[m] \leftarrow [m] + 1$ Skip if $[m]=0$
Affected flag(s)	None
SIZA [m]	Skip if increment Data Memory is zero with result in ACC
Description	The contents of the specified Data Memory are first incremented by 1. If the result is 0, the following instruction is skipped. The result is stored in the Accumulator but the specified Data Memory contents remain unchanged. As this requires the insertion of a dummy instruction while the next instruction is fetched, it is a two cycle instruction. If the result is not 0 the program proceeds with the following instruction.
Operation	$ACC \leftarrow [m] + 1$ Skip if $ACC=0$
Affected flag(s)	None
SNZ [m].i	Skip if bit i of Data Memory is not 0
Description	If bit i of the specified Data Memory is not 0, the following instruction is skipped. As this requires the insertion of a dummy instruction while the next instruction is fetched, it is a two cycle instruction. If the result is 0 the program proceeds with the following instruction.
Operation	Skip if $[m].i \neq 0$
Affected flag(s)	None
SUB A,[m]	Subtract Data Memory from ACC
Description	The specified Data Memory is subtracted from the contents of the Accumulator. The result is stored in the Accumulator. Note that if the result of subtraction is negative, the C flag will be cleared to 0, otherwise if the result is positive or zero, the C flag will be set to 1.
Operation	$ACC \leftarrow ACC - [m]$
Affected flag(s)	OV, Z, AC, C
SUBM A,[m]	Subtract Data Memory from ACC with result in Data Memory
Description	The specified Data Memory is subtracted from the contents of the Accumulator. The result is stored in the Data Memory. Note that if the result of subtraction is negative, the C flag will be cleared to 0, otherwise if the result is positive or zero, the C flag will be set to 1.
Operation	$[m] \leftarrow ACC - [m]$
Affected flag(s)	OV, Z, AC, C
SUB A,x	Subtract immediate data from ACC
Description	The immediate data specified by the code is subtracted from the contents of the Accumulator. The result is stored in the Accumulator. Note that if the result of subtraction is negative, the C flag will be cleared to 0, otherwise if the result is positive or zero, the C flag will be set to 1.
Operation	$ACC \leftarrow ACC - x$
Affected flag(s)	OV, Z, AC, C
SWAP [m]	Swap nibbles of Data Memory
Description	The low-order and high-order nibbles of the specified Data Memory are interchanged.
Operation	$[m].3\sim[m].0 \leftrightarrow [m].7\sim[m].4$
Affected flag(s)	None

SWAPA [m]	Swap nibbles of Data Memory with result in ACC
Description	The low-order and high-order nibbles of the specified Data Memory are interchanged. The result is stored in the Accumulator. The contents of the Data Memory remain unchanged.
Operation	ACC.3~ACC.0 ← [m].7~[m].4 ACC.7~ACC.4 ← [m].3~[m].0
Affected flag(s)	None
SZ [m]	Skip if Data Memory is 0
Description	If the contents of the specified Data Memory is 0, the following instruction is skipped. As this requires the insertion of a dummy instruction while the next instruction is fetched, it is a two cycle instruction. If the result is not 0 the program proceeds with the following instruction.
Operation	Skip if [m]=0
Affected flag(s)	None
SZA [m]	Skip if Data Memory is 0 with data movement to ACC
Description	The contents of the specified Data Memory are copied to the Accumulator. If the value is zero, the following instruction is skipped. As this requires the insertion of a dummy instruction while the next instruction is fetched, it is a two cycle instruction. If the result is not 0 the program proceeds with the following instruction.
Operation	ACC ← [m] Skip if [m]=0
Affected flag(s)	None
SZ [m].i	Skip if bit i of Data Memory is 0
Description	If bit i of the specified Data Memory is 0, the following instruction is skipped. As this requires the insertion of a dummy instruction while the next instruction is fetched, it is a two cycle instruction. If the result is not 0, the program proceeds with the following instruction.
Operation	Skip if [m].i=0
Affected flag(s)	None
TABRD [m]	Read table (specific page or current page) to TBLH and Data Memory
Description	The low byte of the program code addressed by the table pointer (TBHP and TBLP or only TBLP if no TBHP) is moved to the specified Data Memory and the high byte moved to TBLH.
Operation	[m] ← program code (low byte) TBLH ← program code (high byte)
Affected flag(s)	None
TABRDL [m]	Read table (last page) to TBLH and Data Memory
Description	The low byte of the program code (last page) addressed by the table pointer (TBLP) is moved to the specified Data Memory and the high byte moved to TBLH.
Operation	[m] ← program code (low byte) TBLH ← program code (high byte)
Affected flag(s)	None
XOR A,[m]	Logical XOR Data Memory to ACC
Description	Data in the Accumulator and the specified Data Memory perform a bitwise logical XOR operation. The result is stored in the Accumulator.
Operation	ACC ← ACC "XOR" [m]
Affected flag(s)	Z

XORM A,[m] Logical XOR ACC to Data Memory
Description Data in the specified Data Memory and the Accumulator perform a bitwise logical XOR operation. The result is stored in the Data Memory.
Operation $[m] \leftarrow \text{ACC} \text{ "XOR" } [m]$
Affected flag(s) Z

XOR A,x Logical XOR immediate data to ACC
Description Data in the Accumulator and the specified immediate data perform a bitwise logical XOR operation. The result is stored in the Accumulator.
Operation $\text{ACC} \leftarrow \text{ACC} \text{ "XOR" } x$
Affected flag(s) Z

Package Information

Note that the package information provided here is for consultation purposes only. As this information may be updated at regular intervals users are reminded to consult the [Holtek website](#) for the latest version of the [Package/Carton Information](#).

Additional supplementary information with regard to packaging is listed below. Click on the relevant section to be transferred to the relevant website page.

- [Package Information \(include Outline Dimensions, Product Tape and Reel Specifications\)](#)
- [The Operation Instruction of Packing Materials](#)
- [Carton information](#)

16-pin NSOP-EP (150mil) Outline Dimensions

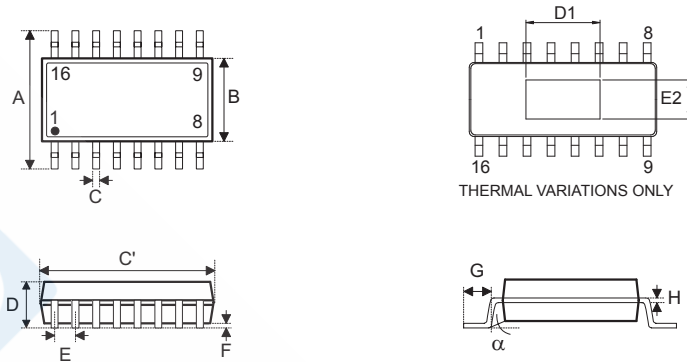

Symbol	Dimensions in inch		
	Min.	Nom.	Max.
A	—	0.236 BSC	—
B	—	0.154 BSC	—
C	0.012	—	0.020
C'	—	0.390 BSC	—
D	—	—	0.069
D1	0.059	—	—
E	—	0.050 BSC	—
E2	0.039	—	—
F	0.000	—	0.006
G	0.016	—	0.050
H	0.004	—	0.010
α	0°	—	8°

Symbol	Dimensions in mm		
	Min.	Nom.	Max.
A	—	6.00 BSC	—
B	—	3.90 BSC	—
C	0.31	—	0.51
C'	—	9.90 BSC	—
D	—	—	1.75
D1	1.50	—	—
E	—	1.27 BSC	—
E2	1.00	—	—
F	0.00	—	0.15
G	0.40	—	1.27
H	0.10	—	0.25
α	0°	—	8°



Singel 3 | B-2550 Kontich | Belgium | Tel. +32 (0)3 458 30 33
info@alcom.be | www.alcom.be
Rivium 1e straat 52 | 2909 LE Capelle aan den IJssel | The Netherlands
Tel. +31 (0)10 288 25 00 | info@alcom.nl | www.alcom.nl

Copyright© 2021 by HOLTEK SEMICONDUCTOR INC.

The information appearing in this Data Sheet is believed to be accurate at the time of publication. However, Holtek assumes no responsibility arising from the use of the specifications described. The applications mentioned herein are used solely for the purpose of illustration and Holtek makes no warranty or representation that such applications will be suitable without further modification, nor recommends the use of its products for application that may present a risk to human life due to malfunction or otherwise. Holtek's products are not authorized for use as critical components in life support devices or systems. Holtek reserves the right to alter its products without prior notification. For the most up-to-date information, please visit our web site at <http://www.holtek.com>.