

# New Methane Sensing Technology Enables Next Generation Applications



Singel 3 | B-2550 Kontich | Belgium | Tel. +32 (0)3 458 30 33  
info@alcom.be | www.alcom.be  
Rivium 1e straat 52 | 2909 LE Capelle aan den IJssel | The Netherlands  
Tel. +31 (0)10 288 25 00 | info@alcom.nl | www.alcom.nl

## TABLE OF CONTENTS

<b>WHY IS METHANE GAS SENSING IMPORTANT? .....</b>	<b>3</b>
<b>NON-DISPERSIVE INFRA-RED (NDIR) SENSORS.....</b>	<b>5</b>
<b>LED EFFICIENCY ADVANTAGES .....</b>	<b>6</b>
<b>METHANE SENSOR DESIGN ARCHITECTURE.....</b>	<b>8</b>
<b>METHANE SENSOR DESIGN GOALS.....</b>	<b>9</b>
<b>METHANE SENSOR APPLICATIONS .....</b>	<b>9</b>
<b>SAFETY CERTIFICATION .....</b>	<b>10</b>
<b>CONCLUSION .....</b>	<b>11</b>
<b>IMPORTANT NOTICE .....</b>	<b>12</b>
<b>ADDRESS.....</b>	<b>12</b>

**WHY IS METHANE GAS SENSING IMPORTANT?**

Climate change, and the control and reduction of air pollution are attracting increased attention across the globe due to their long-term environmental and health impacts. The COVID-19 pandemic has heightened the awareness of our environment and the impact being wrought by our behaviours and activities on the world around us.

Pollution has an immediate damaging impact on the environment and on our well-being. Pollution causing poor indoor air quality has been linked to many health problems such as lung and heart disease and strokes.

Although there are natural sources for some of these pollutant gasses, the major sources of environmental pollution are caused by human activities, such as fossil fuel production and use, waste treatment, agriculture, traffic, and industrial processing.

The effects of intensive farming have a significant impact on the environment. Methane from the production of beef is major contributor to global warming as well as creating environmental damage caused by razing to the ground of rain forest and conversion to grazing.

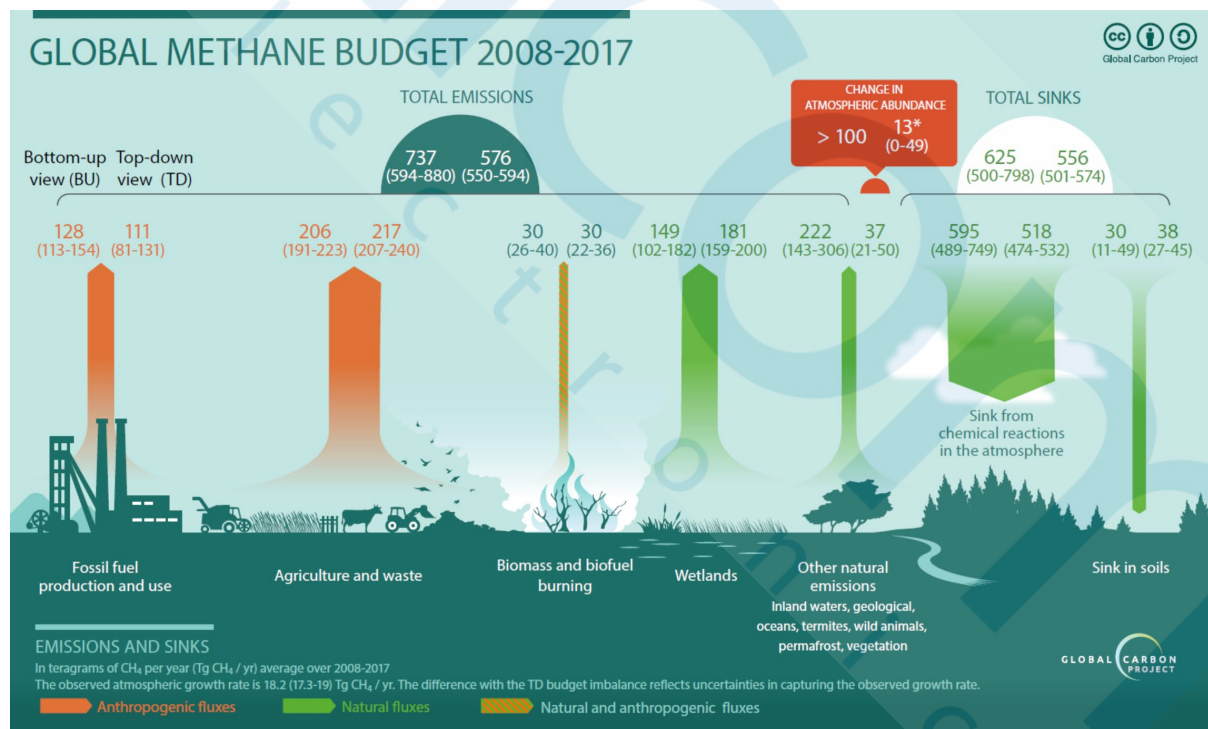

**Figure 1: Source: The Global Methane Budget 2000-2017 (2020) - [www.globalcarbonproject.org/methanebudget](http://www.globalcarbonproject.org/methanebudget)**

During the COVID-19 crisis, many people have been asked to work from home and this has heightened the awareness of having effective hazardous gas safety monitoring systems for employees by their employers. Employers need to take substantive and new steps to ensure the homework environment is safe, and productive.

Governments around the world are beginning to form legislative frameworks to control and subsequently reduce the activities that give rise to the emission of climate change and pollutant gases. Underpinning the legislation, there must be an effective method of monitoring the pollutant gas with sufficient fidelity and specificity to be able to identify the sources and take action to control them. Monitoring the emissions of these sources becomes the first and critical step towards air pollution control and reduction.

Natural gas, which is mainly methane, is a major energy source in domestic and industrial settings. As well as being a contributor to global warming, it is also potentially hazardous due to the risk of explosion.

In all cases, it would be highly desirable to have an accurate, low cost, low power, and compact sensor that is capable of being deployed without the need for expensive infrastructure. This would imply the need for wirelessly connected devices that are suitable for long term unattended battery powered operation, that can be used in a highly localised manner, close to the gas source.

There are several existing technologies available capable of measuring methane, but none are suitable for mass deployment due to the cost, size, and power requirements. Products based on gas chromatography and mass spectroscopy are bulky and too expensive, electrochemical sensors are compact but have a limited lifetime, are often slow to respond, whilst laser based optical spectroscopy can be compact, but is too expensive and power hungry. Other technologies such as pellistors are cost effective but are easily poisoned, consume too much power, and must be replaced regularly.

For Gas Sensing Solutions, the solution to the problem was to develop an ultra-low power methane sensor, suitable for use in battery powered equipment. This was achieved using two advanced technologies; super-bright light emitting diodes (LEDs) and non-dispersive infrared (NDIR) diffusion techniques.

## NON-DISPERSIVE INFRA-RED (NDIR) SENSORS

NDIR sensors work by detecting the amount of light that is absorbed by the target gas. Gases absorb light energy at different wavelengths, depending on the chemical bonds in the gas. The amount of energy absorbed by the target gas is proportional to the concentration. Gases absorb energy at specific wavelengths, as shown below. Light emitting diodes (LEDs) can be tuned to generate some of these different wavelengths, to specifically target the gas of interest.

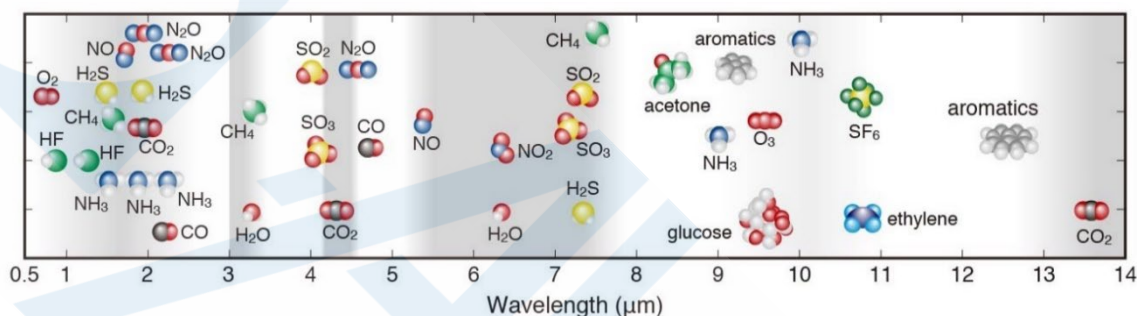

**Figure 2: Gas Absorption Wavelength**

The methane molecule absorbs light at several wavelengths. Leveraging its expertise in the design, development, and manufacturing of mid-infrared LEDs, GSS has targeted the absorption band at 3.25µm. The principle technical challenge in targeting the absorption band at 3.25µm is the proximity of an absorption band for water. In real-life applications, methane and water vapour will typically co-exist and therefore a method is needed to mitigate the effects of water absorption on methane measurement accuracy. The light will be attenuated by not only the methane gas, but also by the presence of water. Water absorbs infrared light in the 2.8µm to 3.0µm band.

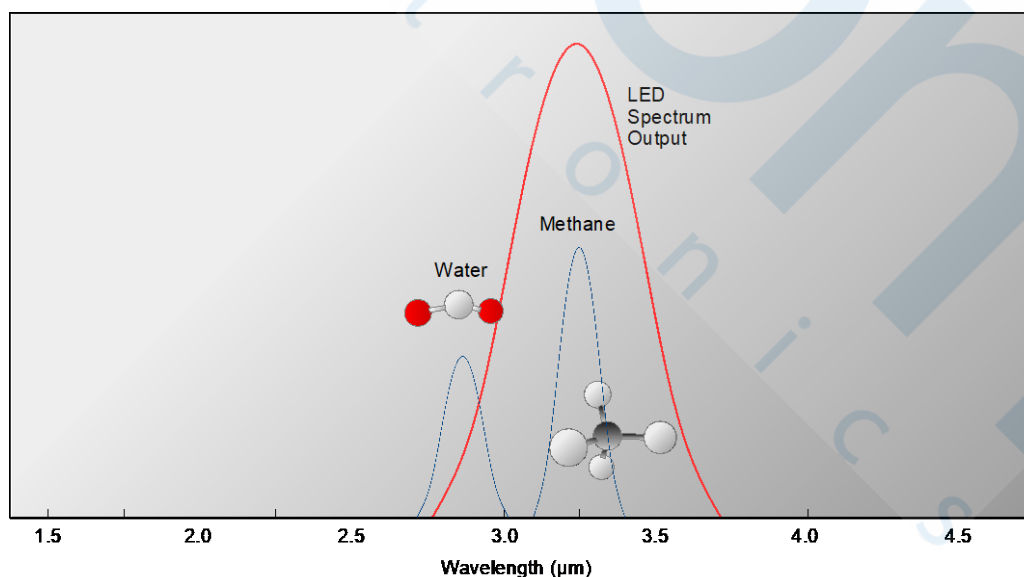

**Figure 3: Absorption Wavelength of Water and Methane, in Comparison to LED Output**

Although the LED output is tuned to a centre wavelength of 3.25 $\mu$ m, LEDs have an emission linewidth that extends over several hundred nanometres. The LED light source will be attenuated by both methane and water that is present in the gas. The design of the methane sensor incorporates a filter to minimise the LED output that overlaps the water absorption band.

## LED EFFICIENCY ADVANTAGES

The power consumption of the sensor is driven by several factors, but principally due to the LED efficiency, how it is driven, and the optical cavity efficiency used for measuring the trace gases.

To minimise power consumption, there are several factors that must be considered. LEDs are semiconductor devices that emit light via the re-combination of electrons and holes within the active region of the device (a sequence of specially designed layers manufactured using a process called molecular beam epitaxy). The efficiency of the LED, known as wall-plug efficiency (WPE), indicates the ratio of radiated power to electrical input power. Wall plug efficiency is a descriptor for several different parameters connected with how efficiently the LED converts electrons to photons. These factors are a facet of the LED design itself. This new generation of 'super-lattice' LEDs can realise WP efficiencies of greater than 50% under the right conditions.

But it's not just about the intrinsic power efficiency of the LED source, it's also about how it is used. The forward current used to drive the LED is a balance of trade-offs. The LED needs to generate enough light at the photo-diode receiver to generate sufficient signal to be processed and converted into a methane gas level measurement. Larger forward currents will generate bigger LED outputs (up to a point), which in turn will be easier to detect, resulting in lower noise measurements. However, a higher drive current will consume more power. This trade-off between LED forward drive current and LED illumination level is a design choice depending on the application and market requirements.

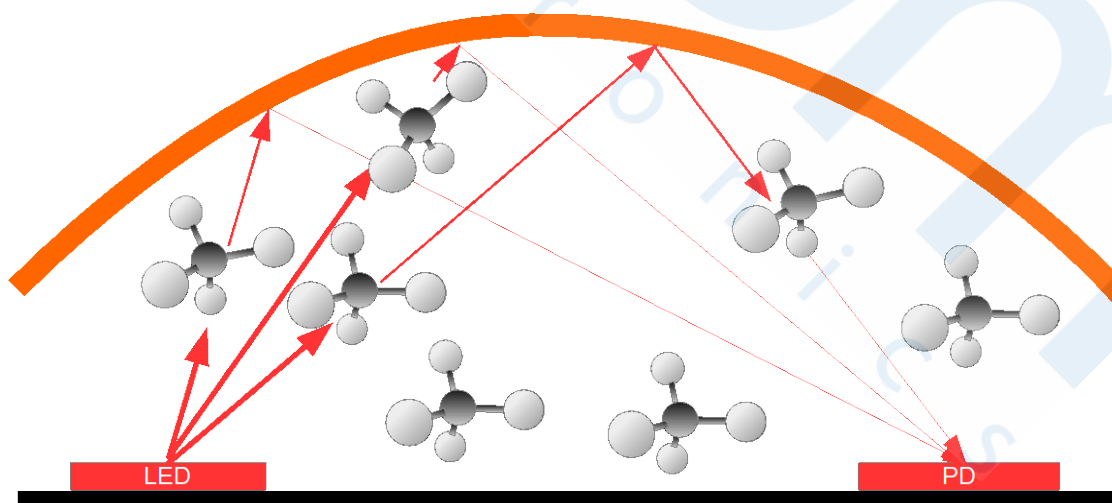

**Figure 4: NDIR Optical Topology**

The last element to consider is the design of the optical cavity itself. The NDIR sensor works by detecting the absorption of the light source by the target gas as it travels towards the PD detector. If the optical path length is too long, the signal at the receiver becomes too small, thus reducing the signal-to-noise, making it hard to achieve good measurement accuracy. This can be overcome by boosting the output of the LED, but at the expense of power consumption. If the optical path length is too short, there will be insufficient absorption, compromising measurement accuracy at low gas concentration levels. The optical path length must be suitable for the anticipated gas range, reduced gas levels require longer path lengths to achieve optimal absorption.

The appropriate choice will be design and market specific. In this case, GSS has chosen to implement its new methane sensor in a small *4 series* style package. This has an internal diameter of less than 20mm. Using some innovative design techniques, GSS has been able to come up with a path length sufficient to detect methane gas concentrations in the range of 0-50,000ppm (0-5%vol or 100%LEL). The LEL is the minimum concentration of methane necessary to support combustion in air is defined as the **Lower Explosive Limit** (LEL) for that gas.

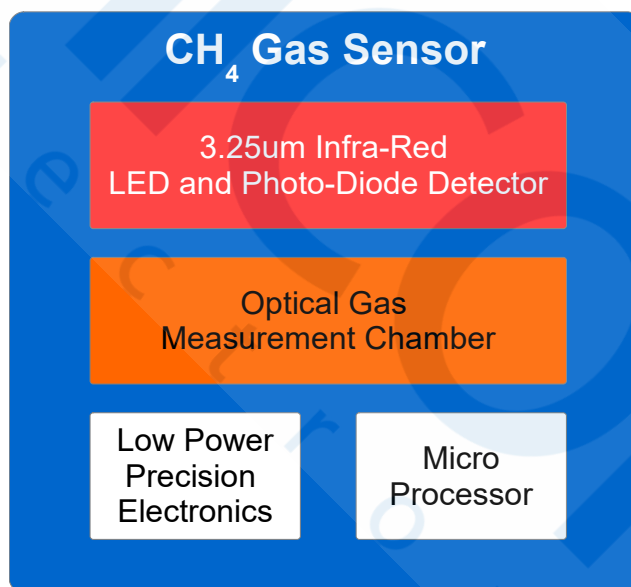
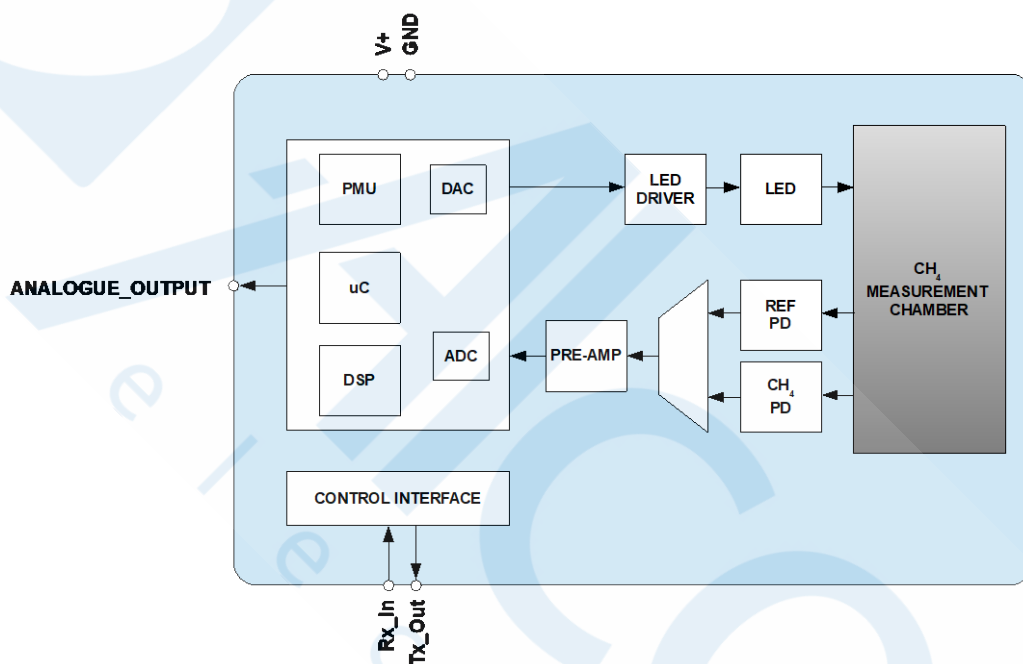

**Figure 5: Core Components of Methane Sensor**

Inside the sensor, which stands <17mm high, and an external diameter of 20mm, is a complete measurement sub-system. As well as the LED light source and detectors, there is a miniature optical measurement cavity, and companion low power signal processing components. The new methane sensor can deliver calibrated digital or analogue methane gas concentration measurements, with no requirement for any off-board signal processing or other post-processing. The sensor comes pre-calibrated for methane but allows the user to modify the calibration for other flammable gas mixtures such as propane, butane and even natural gas in certain conditions.

**METHANE SENSOR DESIGN ARCHITECTURE**

The primary objectives in the development of the methane sensor architecture were to overcome two problems, one as described above, to mitigate the effects of water vapour on measurement accuracy, and the other to counter drift, inherent in all NDIR sensors. A dual-channel architecture was chosen, with one reserved for the main signal channel, and the other used as a reference channel to measure sensor characteristics out with of the measurement gas.



**Figure 6: Block Diagram of FlameIR-ME1 Methane Sensor**

The source LED is spectrally filtered to remove the impact of crosstalk due to absorption in the main signal channel caused by the presence of water. The reference channel detector detects the signal due to water and the methane gas. By comparing the signals from both the signal and reference channels, it is possible to remove the impact of water on methane measurements, even with very high levels of non-condensing humidity in the target gas.

This architecture also largely eliminates the baseline drift inherent in single channel NDIR sensors. Although all GSS sensors are calibrated for accuracy at the factory at multiple concentration levels, in use, the sensor baseline reference level will change due to changes in the optical surfaces, accumulation of dirt in the sensor and other degradations. The change in reference level of the sensor can be cancelled out using a process known as zero-setting. This resets the sensor to a defined concentration level.



In a single channel CO<sub>2</sub> sensor, the drift is eliminated by re-zeroing the sensor on a regular basis, typically using 'fresh air'. For a dual channel methane sensor, this method of reducing baseline drift is not practicable. One of the benefits of the dual-channel architecture is that it provides a mechanism to compare the difference between the signal path and reference path. By tracking the difference between the two channels, it is possible to correct for baseline drift on the main methane signal channel, which is an inherent behavioural trait of semiconductor devices.

## **METHANE SENSOR DESIGN GOALS**

GSS has a reputation for delivering ultra-low power CO<sub>2</sub> sensors, capable of being integrated into battery powered wirelessly connected environmental monitors that can operate for several years without user intervention. This expertise in low power sensors has fed directly into the development of the new methane sensor. Utilising ultra-bright tuned LEDs, with an ultra-efficient optical measurement chamber and drive electronics, the new sensor combines class-leading power consumption and with superior accuracy, not only in ambient conditions but across the range of real-life environments typically experienced by devices in the field.

The use of LEDs enables the sensor to turn on and start taking measurements near instantaneously, with initial readings being reported in 1.28seconds. Whilst active sensor power consumption is already at class-leading levels, average power consumption can be dramatically reduced by power cycling the device, turning it on momentarily to take a measurement and then powering down in the interim. Such strategies are often used in wirelessly connected and battery powered monitoring applications where gas concentration changes are relatively slow.

The new sensor will be factory calibrated for methane but can be re-calibrated to measure other flammable gas mixtures. Regardless of the chosen calibration, the sensor can operate fully autonomously sending measurement values via the digital interface or using the analogue output. The sensor does not need in-use calibration. However, yearly baseline setting may be needed depending on user accuracy requirements.

## **METHANE SENSOR APPLICATIONS**

The introduction of an LED based methane sensor delivers breakthrough performance in many applications. The low power consumption and fast response time make it suitable for wearable safety monitoring devices. For remote leak detection systems, where long term unattended operation is essential, the new methane sensor is an ideal match for new generations of wireless battery powered equipment.

The superior measurement accuracy over a wide range of real-life environmental conditions enables users to deploy the sensor with high confidence in the integrity of the data. This makes it suitable

for general purpose industrial safety critical equipment, where there is a dependency on the sensor to deliver long term reliable data.

## SAFETY CERTIFICATION

The FlameIR-ME1 has been designed for use in Category 1 (Zone 0) equipment intended for high-risk areas where an explosive atmosphere is present for long periods. Many aspects of the design give the sensor an intrinsic safety advantage. By using low power LEDs, the sensor already has properties that provide it with characteristics that do not present a high ignition risk. It does not need a flameproof enclosure, which reduces sensor cost and weight. The FlameIR-ME1 will be certified to ATEX II 1GD Ex ia IIC T4 Gb, making it suitable for most safety critical applications.

ATEX Only			Ex	ia	IIC	T4	Gb
II	I	GD					
Device Group	Device Category	Surrounding Atmosphere	Explosion Protected	Protection Concept	Equipment Grouping	Temperature Class	Equipment Protection Level
I: Devices to be used in mines II: Devices to be used in areas having explosive gases, liquids, or dust	M1: Mines, required to remain functional in the presence of an explosive atmosphere M2: Mines, must be de-energised in the presence of an explosive atmosphere Gas 1: Zone 0 (gas) 2: Zone 1 (gas) 3: Zone 2 (gas)	G: Gas D: Dust		Gas d – Flameproof enclosure e – Increased safety n – Sparking/no-sparking p – Pressurised o – oil immersion q – Powder filled m – Encapsulated i – intrinsic safety	Group I – Mines Group II – Explosive gas other than mines IIA = Propane IIB = ethylene or propane IIC = Hydrogen, ethylene, propane	Gas Temperature class and maximum surface temperature T1 – 450°C T2 – 300°C T3 – 200°C T4 – 135°C T5 – 100°C T6 – 85°C	Ma – Very high level of protection, even when left energised (mines) Mb – High level of protection de-energised (mines) Ga – Very high level (gas) Gb – High level (gas) Gc – Enhanced (gas)
	Dust Zone 20 (dust) Zone 21 (dust) Zone 22 (dust)			Dust m – Encapsulated t - Protection by enclosure pD - Pressurisation	Group III – Explosive dust other than mines IIIA – Combustible dust IIIB – Non-conductive dust (and combustible gas) IIIC – Conductive dust ( and for non-conductive and combustible dust)	Dust Maximum surface temperature with tested dust layer	Da – Very high level (dust) Db – High level (dust) Dc – Enhanced (dust)

## CONCLUSION

GSS has developed its new methane sensor to provide a practical, easy to use solution to the problem of detecting methane gas at concentrations of up to 5%, with an accuracy sufficient to support Industry requirements such as IEC 60079-29-1, yet capable of being used in battery powered wearable devices or where the sensor needs to be capable of supporting long term unattended wirelessly connected operation.

The FlameIR-ME1 methane sensor will be sampling to customers in Q2 2022, with commercial production release in Q3 2022. For more information, please contact your local GSS sales representative. Contact details can be found on our web site, [www.gassensing.co.uk/contact](http://www.gassensing.co.uk/contact).

## IMPORTANT NOTICE

Gas Sensing Solutions Ltd. (GSS) products and services are sold subject to GSS's terms and conditions of sale, delivery and payment supplied at the time of order acknowledgement. GSS warrants performance of its products to the specifications in effect at the date of shipment. GSS reserves the right to make changes to its products and specifications or to discontinue any product or service without notice.

Customers should therefore obtain the latest version of relevant information from GSS to verify that the information is current. Testing and other quality control techniques are utilised to the extent GSS deems necessary to support its warranty. Specific testing of all parameters of each device is not necessarily performed unless required by law or regulation. In order to minimise risks associated with customer applications, the customer must use adequate design and operating safeguards to minimise inherent or procedural hazards. GSS is not liable for applications assistance or customer product design. The customer is solely responsible for its selection and use of GSS products. GSS is not liable for such selection or use nor for use of any circuitry other than circuitry entirely embodied in a GSS product.

GSS products are not intended for use in life support systems, appliances, nuclear systems, or systems where malfunction can reasonably be expected to result in personal injury, death or severe property or environmental damage. Any use of products by the customer for such purposes is at the customer's own risk.

GSS does not grant any licence (express or implied) under any patent right, copyright, mask work right or other intellectual property right of GSS covering or relating to any combination, machine, or process in which its products or services might be or are used. Any provision or publication of any third party's products or services does not constitute GSS's approval, licence, warranty, or endorsement thereof. Any third party trademarks contained in this document belong to the respective third-party owner.

Reproduction of information from GSS datasheets is permissible only if reproduction is without alteration and is accompanied by all associated copyright, proprietary and other notices (including this notice) and conditions. GSS is not liable for any unauthorised alteration of such information or for any reliance placed thereon.

Any representations made, warranties given, and/or liabilities accepted by any person which differ from those contained in this datasheet or in GSS's standard terms and conditions of sale, delivery and payment are made, given and/or accepted at that person's own risk. GSS is not liable for any such representations, warranties, or liabilities or for any reliance placed thereon by any person.



Singel 3 | B-2550 Kontich | Belgium | Tel. +32 (0)3 458 30 33  
info@alcom.be | www.alcom.be  
Rivium 1e straat 52 | 2909 LE Capelle aan den IJssel | The Netherlands  
Tel. +31 (0)10 288 25 00 | info@alcom.nl | www.alcom.nl