

EFACA

Automotive metalized polypropylene film AC filtering capacitor



Photo is representative

Product features

- AEC-Q200
- High capacitance density
- Self-healing property
- High ripple current, low loss
- Optimized AC voltage performance
- Suitable for high frequency applications
- Suitable for harsh environmental conditions
- THB Grade IIIB (+85 °C /85% RH, 1000 hours, U_R)

Applications

- On board charger (OBC)
- xEV traction inverter
- Solar inverter
- UPS
- AC motor drive
- Air conditioner
- Switched mode power supplies
- AC clamping and harmonic filtering

Environmental compliance and general specifications

- Operating temperature range: -55 °C to +105 °C



Part number system

EF	AC	A	30	J	106	E15	4B	H
Capacitor type	Family	Grade	Voltage (Vac)	Tolerance	Capacitance (pF)	Size code	Terminal code	Lead length code
EF = film capacitors	Radial leads AC filtering	A = automotive grade	18=180 25=250 30=300 35=350 40=400 50=500 60=600 76=760	J = ±5% K = ±10%	First two digits= significant figures, third digit = number of zeros example: 106 = 10000000 pF	Refer to size code table	Refer to terminal code table	Refer to lead length code table

Terminal code table

Digit one (Lead/terminal type)	Digit two (Lead Ipsilateral)
2 leads for straight cut	2 10.2 mm B
4 leads for straight cut	4 20.3 mm D
	N/A L

Lead length code table

Lead length	
3.0±0.5 mm (Bulk)	D
3.5±0.5 mm (Bulk)	E
4.0±0.5 mm (Bulk)	F
4.5±0.5 mm (Bulk)	G
5.0±0.5 mm (Bulk)	H
5.5±0.5 mm (Bulk)	J
6.0±0.5 mm (Bulk)	K
6.5±0.5 mm (Bulk)	M
7.0±0.5 mm (Bulk)	N

Dimensions-mm

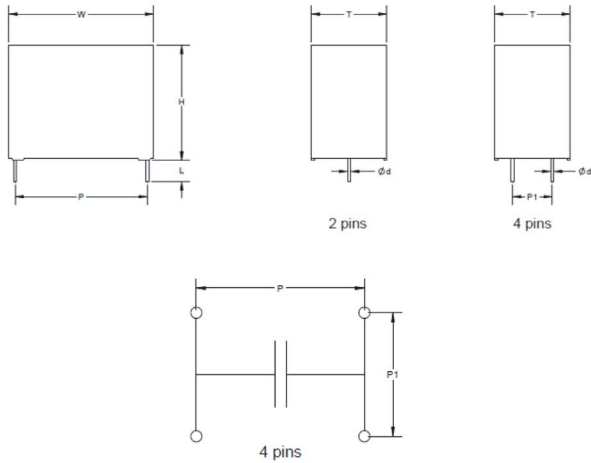

Part marking

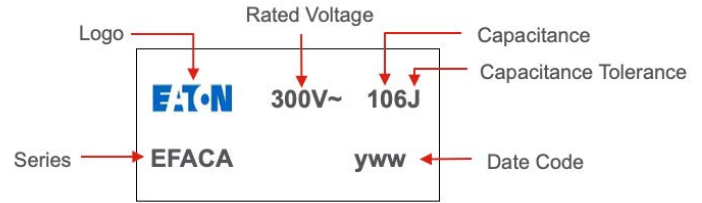

Size code table

Size Family	Dimension-mm					Pitch-mm				OD-mm			Lead length L	
	W	Tolerance (±)	H	Tolerance (±)	T	Tolerance (±)	P	Tolerance (±)	P1	Tolerance (±)	4 leads	2 leads		Tolerance (±)
D02	32	0.8	18	0.8	9	0.8	27.5	0.5	\	\	\	0.8	0.05	Refer to Lead Length Code Table
D03	32	0.8	20	0.8	11	0.8	27.5	0.5	\	\	\	0.8	0.05	
D04	32	0.8	22	0.8	13	0.8	27.5	0.5	\	\	\	0.8	0.05	
D05	32	0.8	24	0.8	14	0.8	27.5	0.5	\	\	\	0.8	0.05	
D07	32	0.8	24.5	0.8	15	0.8	27.5	0.5	\	\	\	0.8	0.05	
D08	32	0.8	28	0.8	14	0.8	27.5	0.5	\	\	\	0.8	0.05	
D09	32	0.8	28	0.8	18	0.8	27.5	0.5	\	\	\	0.8	0.05	
D12	32	0.8	33	0.8	18	0.8	27.5	0.5	\	\	\	0.8	0.05	
D13	32	0.8	37	0.8	22	0.8	27.5	0.5	\	\	\	0.8	0.05	
E06	42	1	30	1.0	16	1.0	37.5	0.5	\	\	\	1.0	0.05	
E07	42	1	30	1.0	17	1.0	37.5	0.5	\	\	\	1.0	0.05	
E10	42	1	32	1.0	19	1.0	37.5	0.5	\	\	\	1.0	0.05	
E11	42	1	37	1.0	22	1.0	37.5	0.5	10.2	0.5	1.2	1.0	0.05	
E14	42	1	43	1.0	28	1.0	37.5	0.5	10.2	0.5	1.2	1.0	0.05	
E15	42	1	44	1.0	24	1.0	37.5	0.5	10.2	0.5	1.2	1.0	0.05	
E16	42	1	45	1.0	30	1.0	37.5	0.5	20.3	0.5	1.2	1.0	0.05	
E17	42	1	50	1.0	35	1.0	37.5	0.5	20.3	0.5	1.2	1.0	0.05	
F02	57.5	1	45	1.0	30	1.0	52.5	0.5	20.3	0.5	1.2	1.2	0.05	
F03	57.5	1	50	1.0	35	1.0	52.5	0.5	20.3	0.5	1.2	1.2	0.05	
F04	57.5	1	55	1.0	45	1.0	52.5	0.5	20.3	0.5	1.2	1.2	0.05	
F05	57.5	1	57.5	1.0	38	1.0	52.5	0.5	20.3	0.5	1.2	1.2	0.05	
F06	57.5	1	65	1.0	45	1.0	52.5	0.5	20.3	0.5	1.2	1.2	0.05	

Remark: case color is black.

Rating and part number

Rated voltage 180 Vac

Capacitance value (μF)	Dimensions					I _{rms} +70 °C, 10 kHz (A)	Peak current (A)	ESR 10 kHz (mΩ)	ESL (nH)	Thermal resistance (°C/W)	dv/dt (V/μs)	Part number ¹
	W (mm)	H (mm)	T (mm)	P (mm)	P1 (mm)							
4	32	22	13	27.5	\	7	300	6.8	16	45	75	EFACA18J405D042LH
5	32	28	18	27.5	\	8	375	5.5	18	42.6	75	EFACA18J505D092LH
6.8	32	33	18	27.5	\	11	510	4.0	20	31	75	EFACA18J685D122LH
10	32	37	22	27.5	\	13	750	2.8	22	31.7	75	EFACA18J106D132LH
10	42	32	19	37.5	\	10	450	5.0	24	30	45	EFACA18J106E102LH
15	42	37	22	37.5	10.2	14	675	3.5	24	21.9	45	EFACA18J156E114BH
18	42	44	24	37.5	10.2	14	810	2.8	24	27.3	45	EFACA18J186E154BH
20	42	44	24	37.5	10.2	15	900	2.5	24	26.7	45	EFACA18J206E154BH
22	42	44	24	37.5	10.2	15	990	2.2	26	30.3	45	EFACA18J226E154BH
25	42	45	30	37.5	20.3	15	1125	2.0	26	33.3	45	EFACA18J256E164DH
30	42	50	35	37.5	20.3	18	1350	1.8	28	25.7	45	EFACA18J306E174DH
33	42	50	35	37.5	20.3	18	1485	1.6	28	28.9	45	EFACA18J336E174DH
40	57.5	45	30	52.5	20.3	20	1000	2.5	30	15	25	EFACA18J406F024DH
50	57.5	50	35	52.5	20.3	24	1250	2.2	32	11.8	25	EFACA18J506F034DH
60	57.5	57.5	38	52.5	20.3	26	1500	1.8	32	12.3	25	EFACA18J606F054DH

1. Standard part numbers listed--additional configurations available for tolerance, terminal and lead length. See part number system for available tolerances and terminal and lead length tables for available options.

Rating and part number

Rated voltage 250 Vac

Capacitance value (μF)	Dimensions					I _{rms} +70 °C, 10 kHz (A)	Peak current (A)	ESR 10 kHz (mΩ)	ESL (nH)	Thermal resistance (°C/W)	dv/dt (V/μs)	Part number ¹
	W (mm)	H (mm)	T (mm)	P (mm)	P1 (mm)							
1	32	18	9	27.5	\	3.0	90	16.5	16	101	90	EFACA25J105D022LH
1.5	32	20	11	27.5	\	4.0	135	10.5	16	89.3	90	EFACA25J155D032LH
2	32	22	13	27.5	\	5.0	180	8.5	16	70.6	90	EFACA25J205D042LH
2.2	32	22	13	27.5	\	6.0	198	7.8	16	53.4	90	EFACA25J225D042LH
2.5	32	22	13	27.5	\	6.0	225	7.5	16	55.6	90	EFACA25J255D042LH
3	32	24.5	15	27.5	\	7.0	270	6.5	16	47.1	90	EFACA25J305D072LH
3.3	32	24.5	15	27.5	\	8.0	297	6.2	16	37.8	90	EFACA25J335D072LH
3.5	32	28	14	27.5	\	8.0	315	5.8	18	40.4	90	EFACA25J355D082LH
4	32	28	18	27.5	\	10	360	4.8	20	31.3	90	EFACA25J405D092LH
4.5	32	33	18	27.5	\	10	405	4.5	20	33.3	90	EFACA25J455D122LH
5	32	33	18	27.5	\	11	450	4.0	20	31	90	EFACA25J505D122LH
6.8	32	37	22	27.5	\	14	612	2.8	22	27.3	90	EFACA25J685D132LH
4.7	42	30	17	37.5	\	7.0	282	7.5	24	40.8	60	EFACA25J475E072LH
5	42	30	17	37.5	\	8.0	300	7.0	24	33.5	60	EFACA25J505E072LH
6	42	30	17	37.5	\	9.0	360	6.0	24	30.9	60	EFACA25J605E072LH
6.5	42	30	17	37.5	\	10	390	5.6	24	26.8	60	EFACA25J655E072LH
6.8	42	32	19	37.5	\	10.5	408	5.4	24	25.2	60	EFACA25J685E102LH
7.5	42	32	19	37.5	\	11	450	5.0	24	24.8	60	EFACA25J755E102LH
8	42	37	22	37.5	10.2	12	480	4.5	24	23.1	60	EFACA25J805E114BH
10	42	37	22	37.5	10.2	13	600	3.6	24	24.7	60	EFACA25J106E114BH
12	42	44	24	37.5	10.2	14	720	3.0	24	25.5	60	EFACA25J126E154BH
15	42	44	24	37.5	10.2	14	900	2.5	24	30.6	60	EFACA25J156E154BH
18	42	43	28	37.5	10.2	15	1080	2.2	26	30.3	60	EFACA25J186E144BH
20	42	45	30	37.5	20.3	15	1200	2.0	26	33.3	60	EFACA25J206E164DH
22	42	50	35	37.5	20.3	18	1320	1.8	28	25.7	60	EFACA25J226E174DH
25	57.5	45	30	52.5	20.3	18	750	3.2	30	14.5	30	EFACA25J256F024DH
30	57.5	45	30	52.5	20.3	20	900	2.8	30	13.4	30	EFACA25J306F024DH
35	57.5	50	35	52.5	20.3	24	1050	2.4	32	10.9	30	EFACA25J356F034DH
40	57.5	57.5	38	52.5	20.3	26	1200	2.0	32	11.1	30	EFACA25J406F054DH

1. Standard part numbers listed---additional configurations available for tolerance, terminal and lead length. See part number system for available tolerances and terminal and lead length tables for available options.

Rating and part number

Rated voltage 300 Vac

Capacitance value (μF)	Dimensions					I _{rms} +70 °C, 10 kHz (A)	Peak current (A)	ESR 10 kHz (mΩ)	ESL (nH)	Thermal resistance (°C/W)	dv/dt (V/μs)	Part number ¹
	W (mm)	H	T (mm)	P (mm)	P1 (mm)							
1	32	20	11	27.5	\	4.0	90	12.5	16	75	90	EFACA30J105D032LH
1.5	32	22	13	27.5	\	5.0	135	8.5	16	70.6	90	EFACA30J155D042LH
2	32	24.5	15	27.5	\	6.0	180	7.5	16	55.6	90	EFACA30J205D072LH
2.2	32	24.5	15	27.5	\	7.0	198	6.8	16	45	90	EFACA30J225D072LH
2.5	32	28	14	27.5	\	8.0	225	6.5	18	36.1	90	EFACA30J255D082LH
3	32	28	18	27.5	\	9.0	270	6.0	20	30.9	90	EFACA30J305D092LH
3.3	32	33	18	27.5	\	10	297	4.8	20	31.3	90	EFACA30J335D122LH
3.5	32	33	18	27.5	\	10.5	315	4.6	20	29.6	90	EFACA30J355D122LH
4	32	33	18	27.5	\	11	360	4.2	20	29.5	90	EFACA30J405D122LH
4.7	32	37	22	27.5	\	13	423	3.8	22	23.4	90	EFACA30J475D132LH
5	32	37	22	27.5	\	13.5	450	3.6	22	22.9	90	EFACA30J505D132LH
5.6	32	37	22	27.5	\	14	504	3.0	22	25.5	90	EFACA30J565D132LH
3	42	30	17	37.5	\	6.0	180	9.0	24	46.3	60	EFACA30J305E072LH
3.3	42	30	17	37.5	\	7.0	198	8.5	24	36	60	EFACA30J335E072LH
3.5	42	30	17	37.5	\	7.0	210	8.0	24	38.3	60	EFACA30J355E072LH
4	42	30	17	37.5	\	8.0	240	6.8	24	34.5	60	EFACA30J405E072LH
4.5	42	30	17	37.5	\	9.0	270	6.0	24	30.9	60	EFACA30J455E072LH
4.7	42	30	17	37.5	\	9.0	282	5.8	24	31.9	60	EFACA30J475E072LH
5	42	32	19	37.5	\	10	300	5.5	24	27.3	60	EFACA30J505E102LH
6	42	32	19	37.5	\	11	360	5.0	24	24.8	60	EFACA30J605E102LH
6.8	42	37	22	37.5	10.2	12	408	4.5	24	23.1	60	EFACA30J685E114BH
8	42	37	22	37.5	10.2	13	480	3.6	24	24.7	60	EFACA30J805E114BH
10	42	44	24	37.5	10.2	14	600	3.0	24	25.5	60	EFACA30J106E154BH
12	42	43	28	37.5	10.2	15	720	2.4	26	27.8	60	EFACA30J126E144BH
15	42	45	30	37.5	20.3	15	900	2.2	26	30.3	60	EFACA30J156E164DH
18	42	50	35	37.5	20.3	18	1080	2.0	28	23.1	60	EFACA30J186E174DH
18	57.5	45	30	52.5	20.3	16	540	3.5	30	16.7	30	EFACA30J186F024DH
20	57.5	45	30	52.5	20.3	18	600	3.2	30	14.5	30	EFACA30J206F024DH
25	57.5	50	35	52.5	20.3	20	750	3.0	32	12.5	30	EFACA30J256F034DH
30	57.5	57.5	38	52.5	20.3	24	900	2.4	32	10.9	30	EFACA30J306F054DH

1. Standard part numbers listed---additional configurations available for tolerance, terminal and lead length. See part number system for available tolerances and terminal and lead length tables for available options.

Rating and part number

Rated voltage 350 Vac

Capacitance value (μF)	Dimensions					I _{rms} +70 °C, 10 kHz (A)	Peak current (A)	ESR 10 kHz (mΩ)	ESL (nH)	Thermal resistance (°C/W)	dv/dt (V/μs)	Part number ¹
	W (mm)	H (mm)	T (mm)	P (mm)	P1 (mm)							
0.33	32	18	9.0	27.5	\	1.5	33	45	16	148.1	100	EFACA35J334D022LH
0.39	32	18	9.0	27.5	\	1.6	39	40	16	146.5	100	EFACA35J394D022LH
0.47	32	18	9.0	27.5	\	2.0	47	35	16	107.1	100	EFACA35J474D022LH
0.68	32	20	11	27.5	\	2.5	68	24	16	100	100	EFACA35J684D032LH
0.82	32	22	13	27.5	\	3.0	82	20.5	16	81.3	100	EFACA35J824D042LH
1	32	22	13	27.5	\	3.2	100	15.5	16	94.5	100	EFACA35J105D042LH
1.5	32	24.5	15	27.5	\	4.0	150	13	16	72.1	100	EFACA35J155D072LH
2	32	28	18	27.5	\	4.8	200	10.8	18	60.3	100	EFACA35J205D092LH
2.2	32	28	18	27.5	\	5.0	220	10.2	18	58.8	100	EFACA35J225D092LH
2.5	32	33	18	27.5	\	6.0	250	7.0	20	59.5	100	EFACA35J255D122LH
3	32	37	22	27.5	\	7.0	300	5.8	22	52.8	100	EFACA35J305D132LH
3.3	32	37	22	27.5	\	7.5	330	5.2	22	51.3	100	EFACA35J335D132LH
3.5	32	37	22	27.5	\	7.8	350	5.0	22	49.3	100	EFACA35J355D132LH
4	32	37	22	27.5	\	8.0	400	4.5	22	52.1	100	EFACA35J405D132LH
2	42	30	17	37.5	\	4.5	140	12.8	24	57.9	70	EFACA35J205E072LH
2.2	42	30	17	37.5	\	4.8	154	12.5	24	52.1	70	EFACA35J225E072LH
2.5	42	30	17	37.5	\	5.2	175	11.8	24	47	70	EFACA35J255E072LH
3	42	30	17	37.5	\	5.5	210	10.8	24	45.9	70	EFACA35J305E072LH
3.3	42	30	17	37.5	\	6.0	231	8.8	24	47.3	70	EFACA35J335E072LH
3.5	42	30	17	37.5	\	6.5	245	8.6	24	41.3	70	EFACA35J355E072LH
4	42	32	19	37.5	\	7.0	280	8.0	24	38.3	70	EFACA35J405E102LH
4.5	42	37	22	37.5	10.2	8.0	315	7.0	24	33.5	70	EFACA35J455E114BH
5	42	37	22	37.5	10.2	8.5	350	6.8	24	30.5	70	EFACA35J505E114BH
5.5	42	37	22	37.5	10.2	8.8	385	6.4	24	30.3	70	EFACA35J555E114BH
6	42	44	24	37.5	10.2	9.5	420	6.0	24	27.7	70	EFACA35J605E154BH
6.5	42	44	24	37.5	10.2	10	455	5.5	24	27.3	70	EFACA35J655E154BH
7	42	44	24	37.5	10.2	10.5	490	5.2	24	26.2	70	EFACA35J705E154BH
8	42	44	24	37.5	10.2	10.5	560	5.2	24	26.2	70	EFACA35J805E154BH
8.5	42	43	28	37.5	10.2	11	595	4.8	26	25.8	70	EFACA35J855E144BH
9	42	43	28	37.5	10.2	11	630	4.6	26	26.9	70	EFACA35J905E144BH
9.5	42	45	30	37.5	20.3	11.5	665	4.4	26	25.8	70	EFACA35J955E164DH
10	42	45	30	37.5	20.3	12	700	4.2	26	24.8	70	EFACA35J106E164DH
12	42	50	35	37.5	20.3	14	840	3.6	28	21.3	70	EFACA35J126E174DH
15	57.5	45	30	52.5	20.3	16.5	600	3.5	30	15.7	40	EFACA35J156F024DH
18	57.5	50	35	52.5	20.3	18	720	3.0	32	15.4	40	EFACA35J186F034DH
20	57.5	57.5	38	52.5	20.3	20	800	2.8	32	13.4	40	EFACA35J206F054DH
22	57.5	57.5	38	52.5	20.3	22	880	2.6	32	11.9	40	EFACA35J226F054DH
25	57.5	55	45	52.5	20.3	24	1000	2.4	32	10.9	40	EFACA35J256F044DH
30	57.5	65	45	52.5	20.3	26	1200	2.2	32	10.1	40	EFACA35J306F064DH

1. Standard part numbers listed---additional configurations available for tolerance, terminal and lead length. See part number system for available tolerances and terminal and lead length tables for available options.

Rating and part number

Rated voltage 400 Vac

Capacitance value (μF)	Dimensions					I _{rms} +70 °C, 10 kHz (A)	Peak current (A)	ESR 10 kHz (mΩ)	ESL (nH)	Thermal resistance (°C/W)	dv/dt (V/μs)	Part number ¹
	W (mm)	H (mm)	T (mm)	P (mm)	P1 (mm)							
0.33	32	18	9.0	27.5	\	1.5	39.6	45	16	148.1	120	EFACA40J334D022LH
0.39	32	18	9.0	27.5	\	1.6	46.8	40	16	146.5	120	EFACA40J394D022LH
0.47	32	18	9.0	27.5	\	2.0	56.4	35	16	107.1	120	EFACA40J474D022LH
0.68	32	20	11	27.5	\	2.5	81.6	24	16	100	120	EFACA40J684D032LH
0.82	32	22	13	27.5	\	3.0	98.4	20.5	16	81.3	120	EFACA40J824D042LH
1	32	24	14	27.5	\	3.2	120	15.5	16	94.5	120	EFACA40J105D052LH
1.5	32	28	18	27.5	\	4.8	180	10.8	18	60.3	120	EFACA40J155D092LH
2	32	33	18	27.5	\	6.0	240	7.0	20	59.5	120	EFACA40J205D122LH
2.2	32	33	18	27.5	\	6.0	264	7.0	20	59.5	120	EFACA40J225D122LH
2.5	32	37	22	27.5	\	7.0	300	5.8	22	52.8	120	EFACA40J255D132LH
3	32	37	22	27.5	\	7.5	360	5.2	22	51.3	120	EFACA40J305D132LH
2	42	30	17	37.5	\	4.5	160	12.8	24	57.9	80	EFACA40J205E072LH
2.2	42	30	17	37.5	\	4.8	176	12.5	24	52.1	80	EFACA40J225E072LH
2.5	42	30	17	37.5	\	5.2	200	11.8	24	47	80	EFACA40J255E072LH
3	42	32	19	37.5	\	6.0	240	8.8	24	47.3	80	EFACA40J305E102LH
3.3	42	32	19	37.5	\	6.5	264	8.6	24	41.3	80	EFACA40J335E102LH
3.5	42	37	22	37.5	10.2	7.0	280	8.0	24	38.3	80	EFACA40J355E114BH
4	42	37	22	37.5	10.2	8.0	320	7.0	24	33.5	80	EFACA40J405E114BH
4.5	42	37	22	37.5	10.2	8.5	360	6.8	24	30.5	80	EFACA40J455E114BH
5	42	44	24	37.5	10.2	9.5	400	6.0	24	27.7	80	EFACA40J505E154BH
5.5	42	44	24	37.5	10.2	10	440	5.5	24	27.3	80	EFACA40J555E154BH
6	42	43	28	37.5	10.2	10.5	480	4.8	26	28.3	80	EFACA40J605E144BH
6.5	42	43	28	37.5	10.2	10.5	520	4.6	26	29.6	80	EFACA40J655E144BH
7	42	43	28	37.5	10.2	11	560	4.4	26	28.2	80	EFACA40J705E144BH
7.5	42	45	30	37.5	20.3	11	600	4.4	26	28.2	80	EFACA40J755E164DH
8	42	45	30	37.5	20.3	11.5	640	4.2	26	27	80	EFACA40J805E164DH
9	42	50	35	37.5	20.3	12.5	720	4.0	28	24	80	EFACA40J905E174DH
10	42	50	35	37.5	20.3	14	800	3.6	28	21.3	80	EFACA40J106E174DH
10	57.5	45	30	52.5	20.3	12.5	500	4.2	30	22.9	50	EFACA40J106F024DH
12	57.5	50	35	52.5	20.3	14	600	3.8	32	20.1	50	EFACA40J126F034DH
14	57.5	50	35	52.5	20.3	16	700	3.6	32	16.3	50	EFACA40J146F034DH
18	57.5	57.5	38	52.5	20.3	20	900	3.0	32	12.5	50	EFACA40J186F054DH
20	57.5	55	45	52.5	20.3	22	1000	2.8	32	11.1	50	EFACA40J206F044DH
22	57.5	65	45	52.5	20.3	24	1100	2.5	32	10.4	50	EFACA40J226F064DH
25	57.5	65	45	52.5	20.3	26	1250	2.2	32	10.1	50	EFACA40J256F064DH

1. Standard part numbers listed--additional configurations available for tolerance, terminal and lead length. See part number system for available tolerances and terminal and lead length tables for available options.

Rating and part number

Rated voltage 500 Vac

Capacitance value (μF)	Dimensions					I _{rms} +70 °C, 10 kHz (A)	Peak current (A)	ESR 10 kHz (mΩ)	ESL (nH)	Thermal resistance (°C/W)	dv/dt (V/μs)	Part number ¹
	W (mm)	H (mm)	T (mm)	P (mm)	P1 (mm)							
0.22	32	18	9.0	27.5	\	1.5	30.8	45	16	148.1	140	EFACA50J224D022LH
0.27	32	18	9.0	27.5	\	1.6	37.8	40	16	146.5	140	EFACA50J274D022LH
0.33	32	20	11	27.5	\	2.5	46.2	24	16	100	140	EFACA50J334D032LH
0.39	32	20	11	27.5	\	2.5	54.6	24	16	100	140	EFACA50J394D032LH
0.47	32	22	13	27.5	\	2.8	65.8	21.5	16	89	140	EFACA50J474D042LH
0.56	32	22	13	27.5	\	3.0	78.4	20.5	16	81.3	140	EFACA50J564D042LH
0.68	32	24.5	15	27.5	\	3.5	95.2	15.5	16	79	140	EFACA50J684D072LH
0.82	32	28	18	27.5	\	4.8	114.8	12.5	18	52.1	140	EFACA50J824D092LH
1	32	33	18	27.5	\	6.0	140	9.0	20	46.3	140	EFACA50J105D122LH
1.2	32	33	18	27.5	\	6.0	168	9.0	20	46.3	140	EFACA50J125D122LH
1.5	32	37	22	27.5	\	7.0	210	8.5	22	36	140	EFACA50J155D132LH
1.8	32	37	22	27.5	\	7.5	252	7.8	22	34.2	140	EFACA50J185D132LH
1	42	30	17	37.5	\	4.5	90	12.8	24	57.9	90	EFACA50J105E072LH
1.2	42	30	17	37.5	\	4.8	108	12.5	24	52.1	90	EFACA50J125E072LH
1.5	42	30	16	37.5	\	5.2	135	11.8	24	47	90	EFACA50J155E062LH
1.8	42	32	19	37.5	\	6.0	162	9.0	24	46.3	90	EFACA50J185E102LH
2	42	32	19	37.5	\	6.5	180	8.6	24	41.3	90	EFACA50J205E102LH
2.5	42	37	22	37.5	10.2	7.0	225	8.0	24	38.3	90	EFACA50J255E114BH
2.8	42	37	22	37.5	10.2	8.0	252	7.0	24	33.5	90	EFACA50J285E114BH
3	42	37	22	37.5	10.2	8.5	270	6.8	24	30.5	90	EFACA50J305E114BH
3.5	42	44	24	37.5	10.2	9.5	315	6.0	24	27.7	90	EFACA50J355E154BH
4	42	43	28	37.5	10.2	10.5	360	4.8	26	28.3	90	EFACA50J405E144BH
4.5	42	43	28	37.5	10.2	10.5	405	4.8	26	28.3	90	EFACA50J455E144BH
5	42	45	30	37.5	20.3	11	450	4.5	26	27.5	90	EFACA50J505E164DH
5.5	42	50	35	37.5	20.3	12.5	495	4.2	28	22.9	90	EFACA50J555E174DH
6	42	50	35	37.5	20.3	14	540	3.8	28	20.1	90	EFACA50J605E174DH
7	57.5	45	30	52.5	20.3	12.5	420	4.2	30	22.9	60	EFACA50J705F024DH
8	57.5	50	35	52.5	20.3	14	480	3.8	32	20.1	60	EFACA50J805F034DH
9	57.5	50	35	52.5	20.3	16	540	3.6	32	16.3	60	EFACA50J905F034DH
10	57.5	57.5	38	52.5	20.3	18	600	3.4	32	13.6	60	EFACA50J106F054DH
12	57.5	57.5	38	52.5	20.3	20	720	3.2	32	11.7	60	EFACA50J126F054DH
15	57.5	65	45	52.5	20.3	22	900	3.0	32	10.3	60	EFACA50J156F064DH

1. Standard part numbers listed---additional configurations available for tolerance, terminal and lead length. See part number system for available tolerances and terminal and lead length tables for available options.

Rating and part number

Rated voltage 600 Vac

Capacitance value (μF)	Dimensions					I _{rms} +70 °C, 10 kHz (A)	Peak current (A)	ESR 10 kHz (mΩ)	ESL (nH)	Thermal resistance (°C/W)	dv/dt (V/μs)	Part number ¹
	W (mm)	H (mm)	T (mm)	P (mm)	P1 (mm)							
0.15	32	18	9.0	27.5	\	1.5	24	45	16	148.1	160	EFACA60J154D022LH
0.22	32	20	11	27.5	\	2.5	35.2	24	16	100	160	EFACA60J224D032LH
0.33	32	22	13	27.5	\	2.8	52.8	21.5	16	89	160	EFACA60J334D042LH
0.47	32	24.5	15	27.5	\	3.2	75.2	15.5	16	94.5	160	EFACA60J474D072LH
0.56	32	28	14	27.5	\	4.0	89.6	12.5	18	75	160	EFACA60J564D082LH
0.68	32	28	18	27.5	\	4.8	108.8	10.8	18	60.3	160	EFACA60J684D092LH
0.82	32	33	18	27.5	\	6.0	131.2	7.0	20	59.5	160	EFACA60J824D122LH
1	32	33	18	27.5	\	6.0	160	7.0	20	59.5	160	EFACA60J105D122LH
1.2	32	37	22	27.5	\	7.0	192	5.8	22	52.8	160	EFACA60J125D132LH
1	42	30	17	37.5	\	4.5	100	12.8	24	57.9	100	EFACA60J105E072LH
1.2	42	32	19	37.5	\	6.0	120	8.8	24	47.3	100	EFACA60J125E102LH
1.5	42	32	19	37.5	\	6.5	150	8.6	24	41.3	100	EFACA60J155E102LH
1.8	42	37	22	37.5	10.2	7.0	180	8.0	24	38.3	100	EFACA60J185E114BH
2	42	37	22	37.5	10.2	8.0	200	7.0	24	33.5	100	EFACA60J205E114BH
2.2	42	44	24	37.5	10.2	9.0	220	6.5	24	28.5	100	EFACA60J225E154BH
2.5	42	44	24	37.5	10.2	9.5	250	6.0	24	27.7	100	EFACA60J255E154BH
2.8	42	43	28	37.5	10.2	10	280	5.5	26	27.3	100	EFACA60J285E144BH
3	42	45	30	37.5	20.3	10.5	300	5.0	26	27.2	100	EFACA60J305E164DH
3.5	42	50	35	37.5	20.3	12.5	350	4.5	28	21.3	100	EFACA60J355E174DH
4	42	50	35	37.5	20.3	14	400	4.0	28	19.1	100	EFACA60J405E174DH
4.5	57.5	45	30	52.5	20.3	12.5	315	4.5	30	21.3	70	EFACA60J455F024DH
5	57.5	45	30	52.5	20.3	13.5	350	4.2	30	19.6	70	EFACA60J505F024DH
6	57.5	50	35	52.5	20.3	14	420	4.0	32	19.1	70	EFACA60J605F034DH
6.5	57.5	50	35	52.5	20.3	16	455	3.8	32	15.4	70	EFACA60J655F034DH
7	57.5	57.5	38	52.5	20.3	18	490	3.6	32	12.9	70	EFACA60J705F054DH
7.5	57.5	57.5	38	52.5	20.3	19	525	3.4	32	12.2	70	EFACA60J755F054DH
8	57.5	57.5	38	52.5	20.3	20	560	3.2	32	11.7	70	EFACA60J805F054DH
10	57.5	65	45	52.5	20.3	22	700	3.0	32	10.3	70	EFACA60J106F064DH

1. Standard part numbers listed---additional configurations available for tolerance, terminal and lead length. See part number system for available tolerances and terminal and lead length tables for available options.

Rating and part number

Rated voltage 760 Vac

Capacitance value (μF)	Dimensions					I _{rms} +70 °C, 10 kHz (A)	Peak current (A)	ESR 10 kHz (mΩ)	ESL (nH)	Thermal resistance (°C/W)	dv/dt (V/μs)	Part number ¹
	W (mm)	H (mm)	T (mm)	P (mm)	P1 (mm)							
0.1	32	18	9.0	27.5	\	1.5	20	45	16	148.1	200	EFACA76J104D022LH
0.15	32	20	11	27.5	\	2.5	30	24	16	100	200	EFACA76J154D032LH
0.22	32	22	13	27.5	\	2.8	44	21.5	16	89	200	EFACA76J224D042LH
0.33	32	24.5	15	27.5	\	3.2	66	15.5	16	94.5	200	EFACA76J334D072LH
0.47	32	28	18	27.5	\	4.5	94	12	18	61.7	200	EFACA76J474D092LH
0.56	32	33	18	27.5	\	5.0	112	10.5	20	57.1	200	EFACA76J564D122LH
0.68	32	37	22	27.5	\	6.0	136	9.5	22	43.9	200	EFACA76J684D132LH
0.68	42	30	17	37.5	\	4.5	81.6	12.8	24	57.9	120	EFACA76J684E072LH
0.82	42	32	19	37.5	\	5.5	98.4	10	24	49.6	120	EFACA76J824E102LH
1	42	32	19	37.5	\	6.5	120	9.0	24	39.4	120	EFACA76J105E102LH
1.2	42	37	22	37.5	10.2	7.0	144	8.5	24	36	120	EFACA76J125E114BH
1.5	42	44	24	37.5	10.2	8.0	180	7.5	24	31.3	120	EFACA76J155E154BH
1.8	42	43	28	37.5	10.2	9.5	216	6.5	26	25.6	120	EFACA76J185E144BH
2	42	45	30	37.5	20.3	10.5	240	5.0	26	27.2	120	EFACA76J205E164DH
2.5	42	50	35	37.5	20.3	12.5	300	4.5	28	21.3	120	EFACA76J255E174DH
3	57.5	45	30	52.5	20.3	12.5	240	4.5	30	21.3	80	EFACA76J305F024DH
4	57.5	50	35	52.5	20.3	14	320	4.0	32	19.1	80	EFACA76J405F034DH
5	57.5	57.5	38	52.5	20.3	16	400	3.6	32	16.3	80	EFACA76J505F054DH
6	57.5	55	45	52.5	20.3	18	480	3.4	32	13.6	80	EFACA76J605F044DH
7	57.5	65	45	52.5	20.3	20	560	3.2	32	11.7	80	EFACA76J705F064DH

1. Standard part numbers listed---additional configurations available for tolerance, terminal and lead length. See part number system for available tolerances and terminal and lead length tables for available options.

General information

Application	AC filtering
Dielectric	Metallized polypropylene Film
Reference standard	IEC 61071/EN 61071/AEC-Q200D
Climatic category	55/105/56 IEC 60068-1
Operating temperature range	-55 °C to +105 °C, (+85°C to +105°C, decreasing factor 1.35% per °C for U_R)
Installation	Any position
Storage conditions	Storage time: ≤24 months from the date marked on the package label, Average relative humidity per year ≤70%, RH≤85% for 30 days in one year, Dew is absent, Temperature: -40 °C to +85 °C

Construction

Metallized film	OPP & Al/Zn
Metal sprayed	Sn/Zn Alloy
Connection electrode	Tinned copper wire
Plastic case	Plastic Case (UL94V-0)
Filling	Epoxy Resin (UL94V-0)

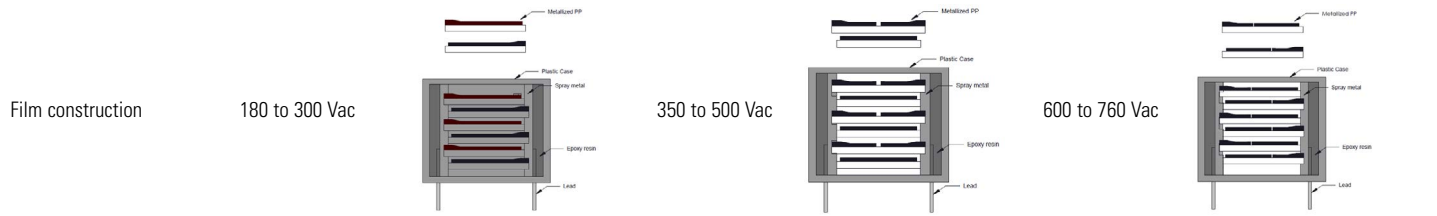

Electrical and general characteristics

Voltage range (U_R)	180 Vac to 760 Vac
Capacitance range	0.1 μ F to 60 μ F
Capacitance tolerance	±5% or ±10% at +20 °C
Capacitance	Measuring frequency at 1 kHz, +20 °C Measuring voltage: 1.0 ±0.2 V
Standard atmospheric conditions for static test	Ambient temperature +15 °C to +35 °C. Relative humidity 45% to 75% Air pressure 86 kPa to 106 kPa.
Withstanding AC voltage between terminals U_{TT}	1.5 x U_R for 10 seconds (between terminations) @ +20 °C ±5 °C
Withstanding AC voltage between terminal and case U_{TC}	3000 Vac, 50/60 Hz 60 s (at +20 ±5 °C)
Dissipation factor	≤20 × 10 ⁻⁴ at 1 kHz; C ≤20 μ F at +25 °C ≤30 × 10 ⁻⁴ at 1 kHz; >20 μ F at +25 °C
Insulation resistance	R between leads, for C ≤ 0.33 μ F at 100 V; 1 min > 100,000 M Ω RC between leads, for C > 0.33 μ F at 100 V; 1 min > 30,000 M Ω * μ F
Self-inductance	<1 nH per mm of lead spacing
Life expectancy	100,000 hours (U_R θ hotspot = +85 °C) (Δ C/C≤5%)
Failure rate	100 FITs (U_R θ hotspot = +85 °C)
Maximum altitude	2000 m
Overvoltage	Maximum duration within one day: Apply 110% of rated voltage 30% of on-load duration Apply 115% of rated voltage 30 minutes Apply 120% of rated voltage 5 minutes Apply 130% of rated voltage 1 minute

Characteristics curves

Expected life curve

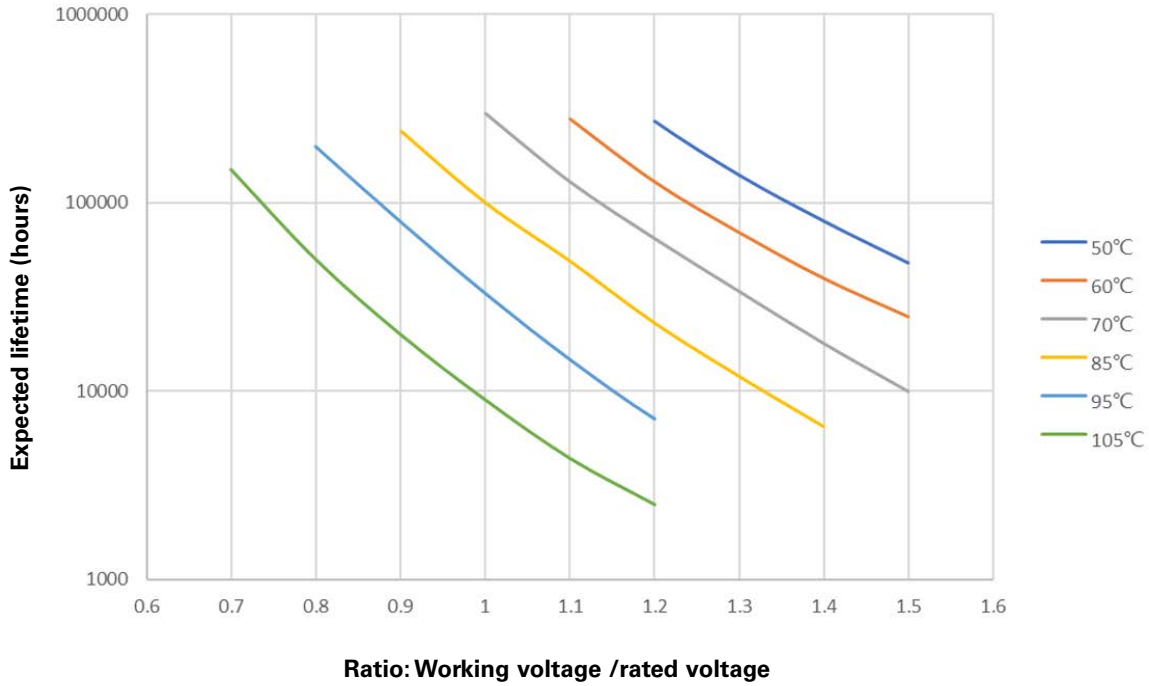

Derating of U_R vs temperature

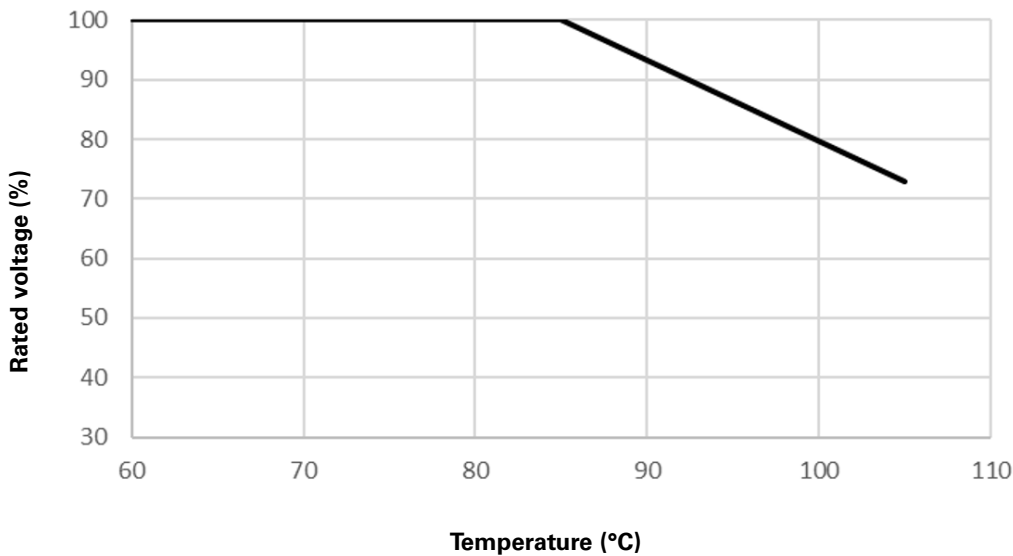

Characteristics curves

Derating of I_{rms} vs temperature

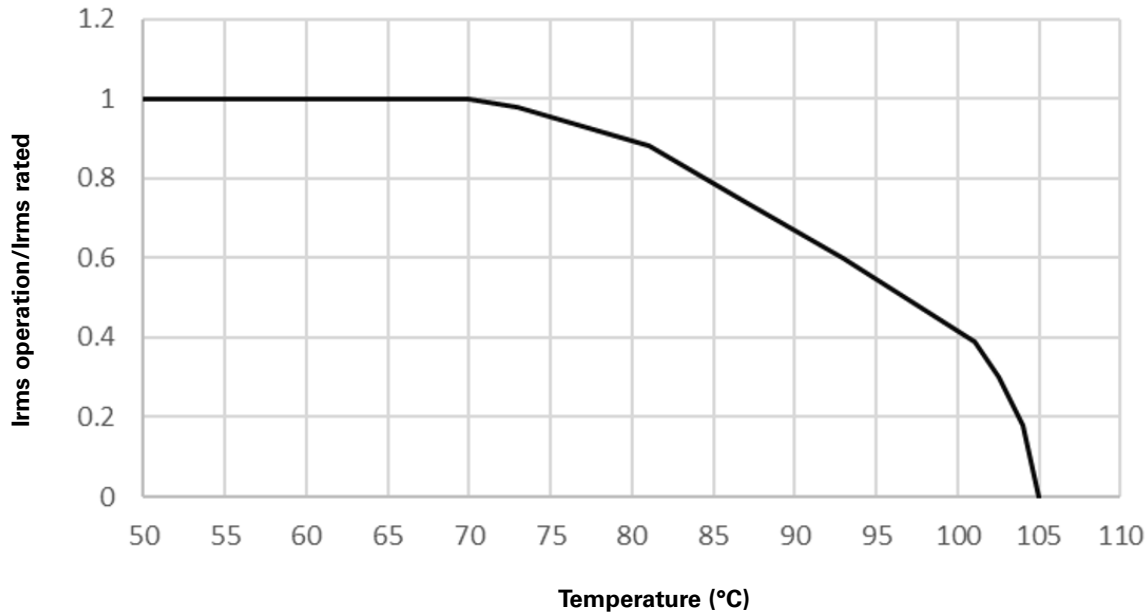

Impedance vs frequency

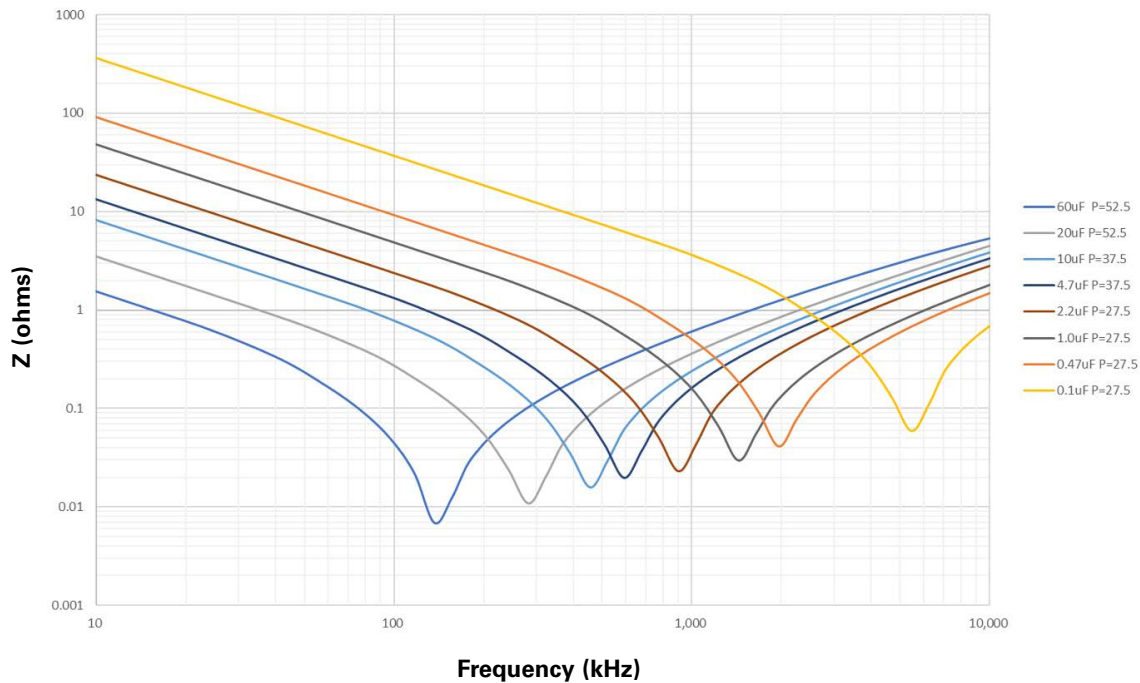

Maximum voltage (Vrms) vs frequency
(Sinusoidal waveform, at +85 °C)

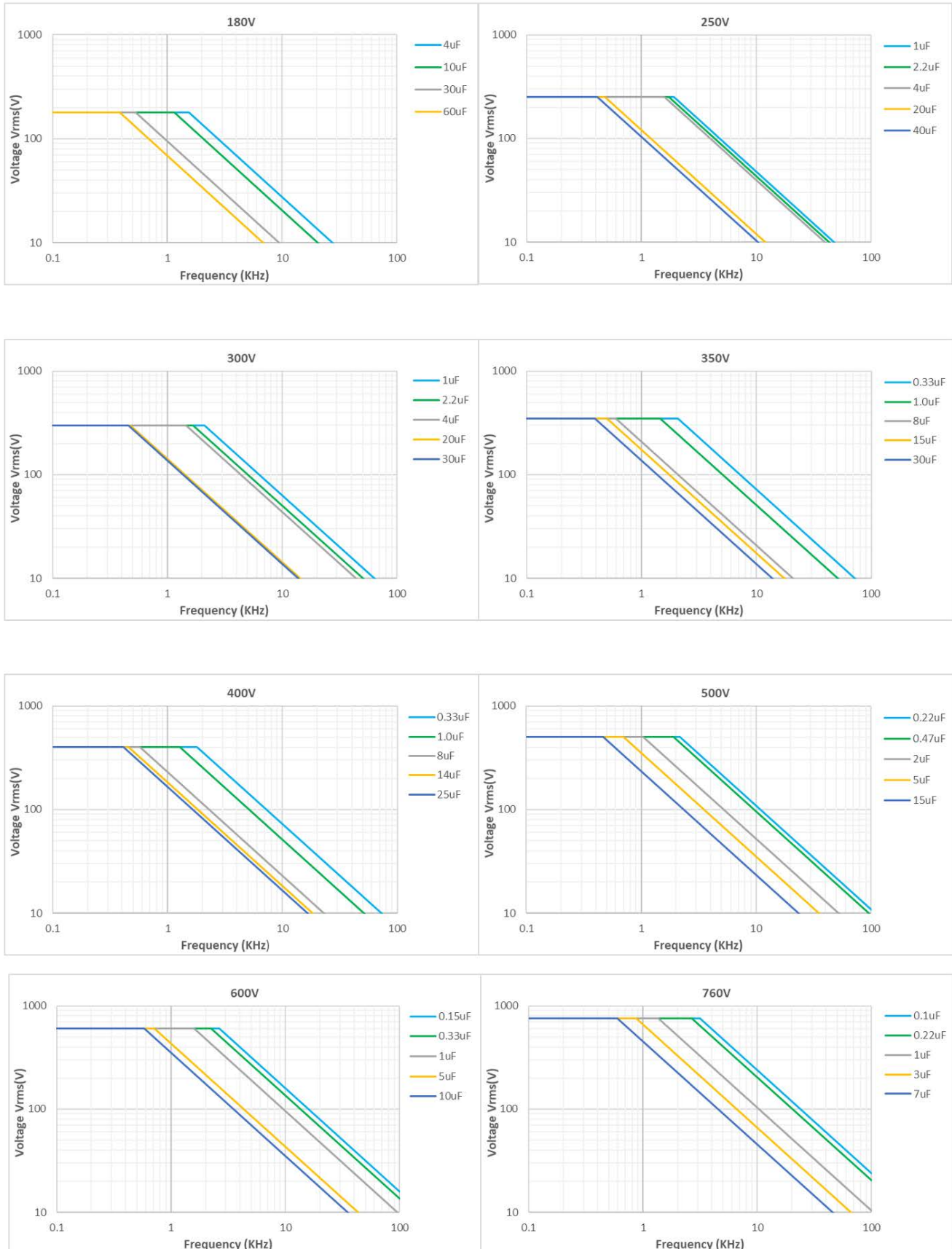

Maximum current (I_{rms}) vs frequency
(Sinusoidal waveform, at +85 °C)

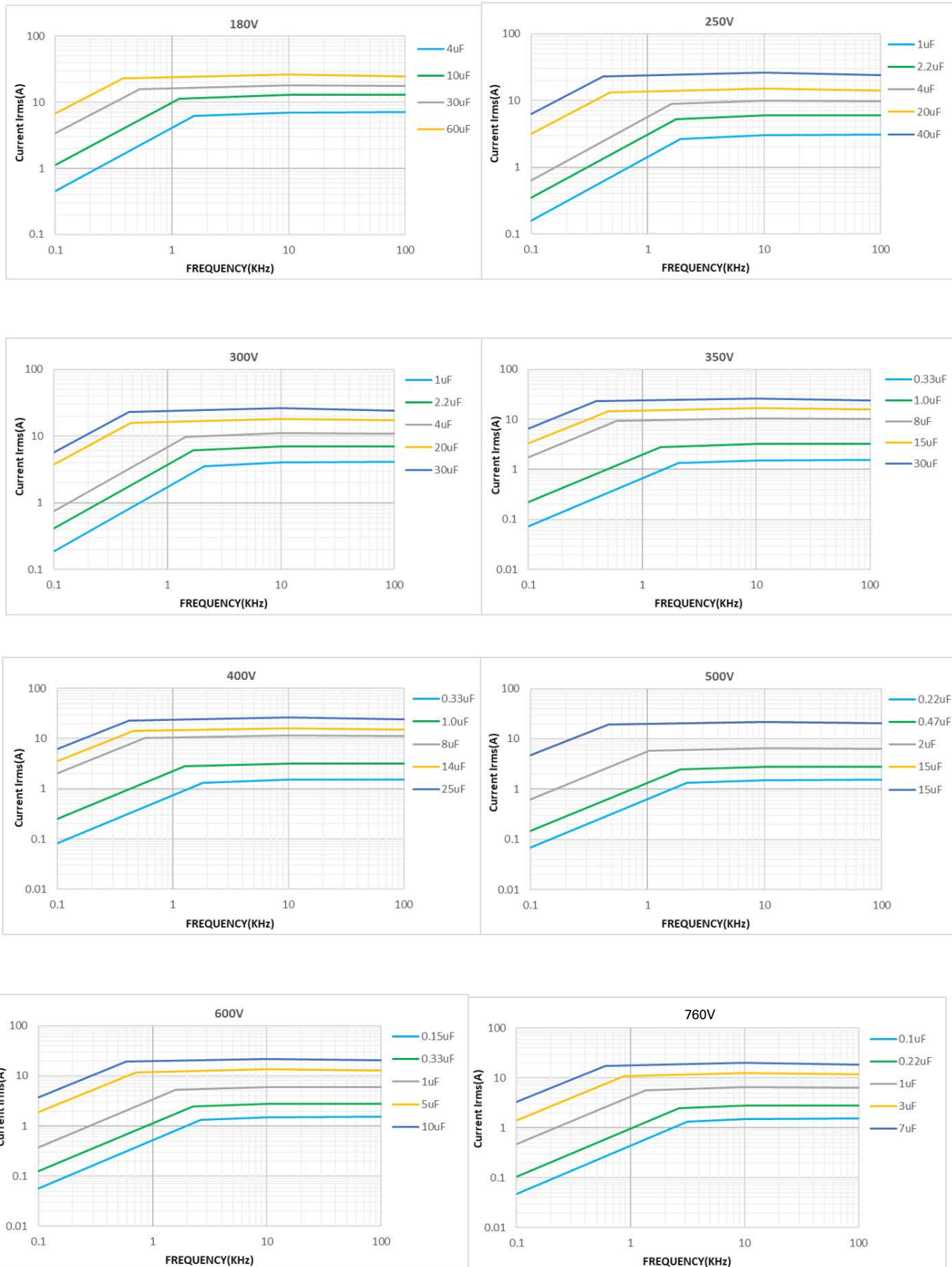

Validation test

Test Item	Test condition	Performance
High temperature exposure	Reference: MIL-STD-202 Method 108 +105+/- 2 °C 1000 hours	Capacitance change rate ($\Delta C/C$): $\leq \pm 3\%$ DF change ($\Delta tg\delta$): $\leq 50 \cdot 10^{-4}$ at 1 kHz Insulation resistance: $\geq 50\%$ of initial limit (T-T) test voltage: $1.5 \times U_R/10$ s (T-C) test voltage: 3000 Vac/60 s
Temperature cycling	Reference: JESD22 Method JA-104 High Temperature: +105+/-5 °C Low Temperature: -55 +/-5 °C 1000 Cycles, 30 minutes for each temperature	Capacitance Change Rate ($\Delta C/C$): $\leq \pm 5\%$ DF change ($\Delta tg\delta$): $\leq 50 \cdot 10^{-4}$ at 1 kHz Insulation Resistance: $\geq 50\%$ of initial limit (T-T) test voltage: $1.5 \times U_R/10$ s (T-C) test voltage: 3000 Vac/60 s
Moisture resistance	Reference: MIL-STD-202 Method 106 (+25 °C to +65 °C for 2.5 hours), (+65 °C for 3 hours), (+65 °C to +25 °C for 2.5 hours), (+25 °C to +65 °C for 2.5 hours), (+65 °C for 3 hours) , (+65 °C to +25 °C for 2.5 hours), (+25 °C for 8 hours) Humidity 90% ~ 100% for 10 cycles	Capacitance Change Rate ($\Delta C/C$): $\leq \pm 5\%$ DF change ($\Delta tg\delta$): $\leq 50 \cdot 10^{-4}$ at 1 kHz Insulation Resistance: $\geq 50\%$ of initial limit (T-T) test voltage: $1.5 \times U_R/10$ s (T-C) test voltage: 3000 Vac/60 s
Biased humidity 1	Reference: MIL-STD-202 Method 103 +60 °C, 95% R.H, Rated voltage, 1000 hours	Capacitance Change Rate ($\Delta C/C$): $\leq \pm 5\%$ DF change ($\Delta tg\delta$): $\leq 80 \cdot 10^{-4}$ at 1 kHz Insulation Resistance: $\geq 50\%$ of initial limit (T-T) test voltage: $1.5 \times U_R/10$ s (T-C) test voltage: 3000 Vac/60 s
Biased humidity 2	Reference: MIL-STD-202 Method 103 +85 °C, 85% R.H ,Rated voltage, 1000 hours	Capacitance Change Rate ($\Delta C/C$): $\leq \pm 10\%$ DF change ($\Delta tg\delta$): $\leq 80 \cdot 10^{-4}$ at 1 kHz Insulation Resistance: $\geq 50\%$ of initial limit (T-T) test voltage: $1.5 \times U_R/10$ s (T-C) test voltage: 3000 Vac/60 s
Operational life 1	Testing method per IEC 61071 Test Temperature: +85 +/-2 °C. Apply 130% of rated voltage) for 1,000 +24/-0 hours. At 500 hours,1000 charges and discharges At 1.4 x I peak (maximum respective peak current in continuous operation)	Capacitance Change Rate ($\Delta C/C$): $\leq \pm 5\%$ DF change ($\Delta tg\delta$): $\leq 50 \cdot 10^{-4}$ at 1 kHz Insulation Resistance: $\geq 50\%$ of initial limit (T-T) test voltage: $1.5 \times U_R/10$ s (T-C) test voltage: 3000 Vac/60 s
Operational life 2	Testing method per IEC 61071 Test Temperature: +105 +/-2 °C. Apply 130% of (75% rated voltage) for 1,000 +24/-0 hours. At 500 hours,1000 charges and discharges At 1.4 x I peak (maximum respective peak current in continuous operation)	Capacitance Change Rate ($\Delta C/C$): $\leq \pm 5\%$ DF change ($\Delta tg\delta$): $\leq 50 \cdot 10^{-4}$ at 1 kHz Insulation Resistance: $\geq 50\%$ of initial limit (T-T) test voltage: $1.5 \times U_R/10$ s (T-C) test voltage: 3000 Vac/60 s
Terminal strength (lead)	Tension: 0.50 < D \leq 0.80, 10 N, 0.80 < D \leq 1.25, 20 N Bending force: 0.50 < D \leq 0.80, 5 N, 0.80 < D \leq 1.25, 10 N Make two successive bends in each direction	No broken and no abnormal Insulation Resistance: $\geq 50\%$ of initial limit (T-T) test voltage: $1.5 \times U_R/10$ s (T-C) test voltage: 3000 Vac/60 s

Validation test

Test Item	Test condition	Performance
Resistance to solvents	Reference: MIL-STD-202 Method 215 Solvent: propanol Immersion time: 3 minutes Drying time: 5 minutes Mechanical treatment: 10 rubbing (toothbrush) 3 cycles	Capacitance change rate ($\Delta C/C$): $\leq \pm 1\%$ DF change ($\Delta tg \delta$): $\leq 50 \times 10^{-4}$ at 1 kHz Insulation resistance: $\geq 50\%$ of initial limit (T-T) test voltage: $1.5 \times U_R/10$ s (T-C) test voltage: 3000 Vac/60 s
Mechanical shock	Reference: MIL-STD-202 Method 213 Pulse-shape: half-sine wave Acceleration: 100 g Duration of pulse: 6 ms, 18 times	Capacitance Change Rate ($\Delta C/C$): $\leq \pm 1\%$ DF change ($\Delta tg \delta$): $\leq 50 \times 10^{-4}$ at 1 kHz Insulation Resistance: $\geq 50\%$ of initial limit (T-T) test voltage: $1.5 \times U_R/10$ s (T-C) test voltage: 3000 Vac/60 s
Vibration	Reference: MIL-STD-202 Method 204 Frequency Change: 10~2000 Hz. 5 g force 20 minutes Direction: X, Y, Z 12 cycles in each direction	Capacitance Change Rate ($\Delta C/C$): $\leq \pm 1\%$ DF change ($\Delta tg \delta$): $\leq 50 \times 10^{-4}$ at 1 kHz Insulation Resistance: $\geq 50\%$ of initial limit (T-T) test voltage: $1.5 \times U_R/10$ s (T-C) test voltage: 3000 Vac/60 s
Resistance to soldering heat	Reference: MIL-STD-202 Method 210 $+260 \pm 5$ °C 10 s	Capacitance Change Rate ($\Delta C/C$): $\leq \pm 0.5\%$ DF change ($\Delta tg \delta$): $\leq 50 \times 10^{-4}$ at 1 kHz Insulation Resistance: $\geq 50\%$ of initial limit (T-T) test voltage: $1.5 \times U_R/10$ s (T-C) test voltage: 3000 Vac/60 s
Solderability	Reference: J-STD-002 Soldering temperature: $+245 \pm 5$ °C 2 s	More than 95% of circumferential surface of lead wire shall be covered with new solder
Electrical characterization	Parametrically test per lot at room temp, -55 °C, +105 °C	electrical performance within spec no physical damage
Passive flammability class B	Test duration for actual volume V $V \leq 250$ for 10 s $250 < V \leq 500$ for 20 s $500 < V \leq 1750$ for 30 s $V > 1750$ for 60 s	After removing test flame from capacitor, the capacitor must not continue to burn for more than 10 seconds. No burning particle must drop from the sample.
Humidity resistance	Reference: MIL-STD-202 Method 106 40 ± 2 °C, 90% to 95% R.H 56 days	Capacitance Change Rate ($\Delta C/C$): $\leq \pm 5\%$ DF change ($\Delta tg \delta$): $\leq 50 \times 10^{-4}$ at 1 kHz Insulation Resistance: $\geq 50\%$ of initial limit (T-T) test voltage: $1.5 \times U_R/10$ s (T-C) test voltage: 3000 Vac/60 s

Electrical test

Test	Test condition	Performance
Self-healing test	Apply 150% of rated voltage Duration: 10 seconds Number of clearings ≤ 5 Clearing = voltage drop of 5 % increase the voltage at 100 V/s till 5 clearings occur with a maximum of $2.5 \times U_R$ for a duration of 10 seconds	Capacitance change rate ($\Delta C/C$): $\leq \pm 0.5\%$ DF change ($\Delta tg \delta$): $\leq 50 \times 10^{-4}$ at 1 kHz Insulation resistance: $\geq 50\%$ of initial limit (T-T) test voltage: $1.5 \times U_R/10$ s (T-C) test voltage: 3000 Vac/60 s
Surge discharge test	Five charges and discharges in ten minutes. Test voltage: $1.1 U_R$ Test current: 1.1 times the maximum impulse current The interelectrode withstand voltage was tested within five minutes after the test.	Capacitance change rate ($\Delta C/C$): $\leq \pm 1.0\%$ DF change ($\Delta tg \delta$): $\leq 50 \times 10^{-4}$ at 1 kHz Insulation resistance: $\geq 50\%$ of initial limit (T-T) test voltage: $1.5 \times U_R/10$ s (T-C) test voltage: 3000 Vac/60 s
Thermal stability	Temperature: ambient temperature +70 °C Test current: $1.1 I_{rms}$ Test frequency: 10 kHz Test time: 48 hours during, the last 6 hours, the temperature of the case near of the top rise shall be measured per 1.5 hours	Capacitance change rate ($\Delta C/C$): $\leq \pm 2.0\%$ DF change ($\Delta tg \delta$): $\leq 50 \times 10^{-4}$ at 1 kHz Insulation resistance: $\geq 50\%$ of initial limit (T-T) test voltage: $1.5 \times U_R/10$ s (T-C) test voltage: 3000 Vac/60 s

Packaging information

Pitch mm	Size	Dimension-mm			Package quantity
	Code	W	H	T	Bulk pack/box
27.5	D02	32	18	9.0	340
	D03	32	20	11	280
	D04	32	22	13	230
	D05	32	24	14	220
	D07	32	24.5	15	200
	D08	32	28	14	220
	D09	32	28	18	170
	D12	32	33	18	170
	D13	32	37	22	140
37.5	E06	42	30	16	133
	E07	42	30	17	126
	E10	42	32	19	112
	E11	42	37	22	98
	E14	42	43	28	77
	E15	42	44	24	91
	E16	42	45	30	70
52.5	E17	42	50	35	63
	F02	58	45	30	50
	F03	58	50	35	45
	F04	58	55	45	35
	F05	58	57.5	38	40
	F06	58	65	45	35

Wave solder profile

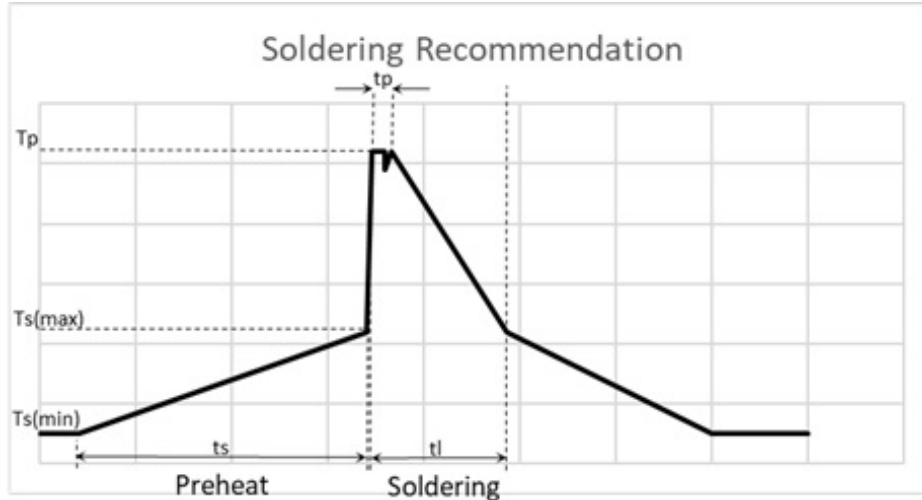

Profile feature

Preheat	• T_s maximum	110 °C
	• T_s minimum	NA
	• t_s	< 150 seconds
Preheat	• T_p	260 °C \pm 5 °C
	• t_p	< 10 seconds
	• t_l	\leq 60 seconds

Capacitor body maximum temperature at wave soldering \leq 120 °C

Manual solder

+400 °C, 3 seconds maximum by soldering iron, generally manual, hand soldering is not recommended

Life Support Policy: Eaton does not authorize the use of any of its products for use in life support devices or systems without the express written approval of an officer of the Company. Life support systems are devices which support or sustain life, and whose failure to perform, when properly used in accordance with instructions for use provided in the labeling, can be reasonably expected to result in significant injury to the user.

Eaton reserves the right, without notice, to change design or construction of any products and to discontinue or limit distribution of any products. Eaton also reserves the right to change or update, without notice, any technical information contained in this bulletin.

Eaton
Electronics Division
1000 Eaton Boulevard
Cleveland, OH 44122
United States
Eaton.com/electronics

Alcom
electronics
A STELLIAU TECHNOLOGY COMPANY

Singel 3 | B-2550 Kontich | Belgium | Tel.+32(0)3 458 30 33
info@alcom.be | www.alcom.be
Rivium 1e straat 52 | 2909 LE Capelle aan den IJssel | The Netherlands
Tel.+31(0)10 288 25 00 | info@alcom.nl | www.alcom.nl