

E9X

Surface mount crystal resonator MHz



Photo is representative

Product features

- 0806 (2016 metric) package
- Moisture sensitivity level (MSL): 1
- Frequency range 16 MHz to 60 MHz
- Variety of frequency tolerance and stability options

Applications

- Wireless applications
- Cell phone
- Modems
- Wireless LAN
- Communication and test equipment
- Laptop
- Network cameras
- Frequency converters

Environmental compliance and general specifications

- Operating temperature range: -40 °C to +85 °C
- Storage temperature range (component): -40 °C to +105 °C



Part number system

E	9	X	260	08	1	G	01
	Size code	Product category	Frequency	Load capacitance	Frequency tolerance	Frequency stability	Internal code
E = Eaton	9 = 2016 metric, 0806 imperial	X = crystal	260 = 26 MHz	08 = 8 pF 10 = 10 pF 12 = 12 pF	1 = ±10 ppm 7 = ±15 ppm 2 = ±20 ppm 4 = ±30 ppm 5 = ±50 ppm	G = ±15 ppm X = ±20 ppm Z = ±50 ppm	01 - 99

Electrical specifications

Items	Parameters
Frequency range	16 MHz to 60 MHz
Oscillation mode	Fundamental
Frequency tolerance at +25 °C	±10, ±15, ±20, ±30, ±50 ppm
Frequency stability vs. operating temperature range	See table below
Equivalent series resistance	See table below
Drive level	10, 100, 200 µW or specify
Insulation resistance	500 MΩ minimum at 100 Vdc
Load capacitance	8, 10, 12 pF or specify
Shunt capacitance (C0)	3 pF maximum or specify
Aging at +25 °C	±3 ppm (first year)

Frequency stability vs. operating temperature range table

ppm	±15	±20	±50
Operating temperature -40 °C to +85 °C	x	x	x

Equivalent series resistance table

Frequency (MHz)	ESR (Ω) maximum	Oscillation mode
16 to 20	100	Fundamental
20 to 32	80	
32 to 54	50	
54 to 60	30	

Construction

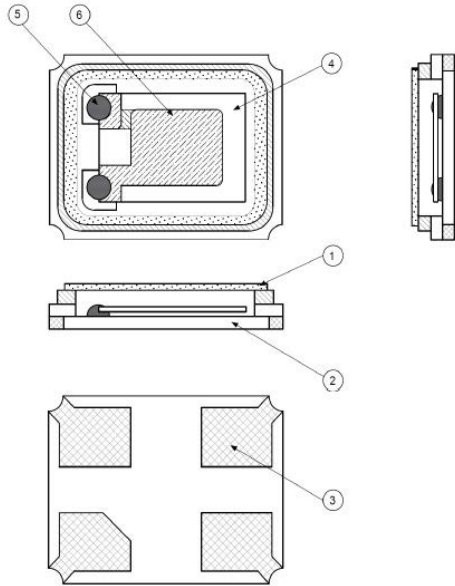

Item number	Component	Description
1	Cap (lid)	Kovar (Fe-Ni-Co)
2	Base (package)	Almina Ceramic (Al ₂ O ₃)
3	Pad (package)	Ni + Au
4	Crystal blank	SiO ₂
5	Conductive adhesive	Ag
6	Electrode	Cr + Ag

Dimensions -mm

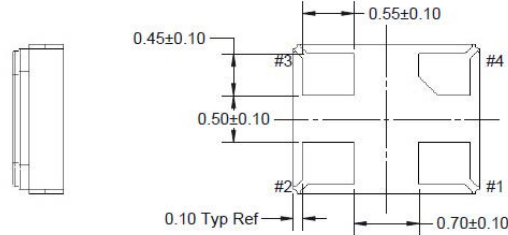
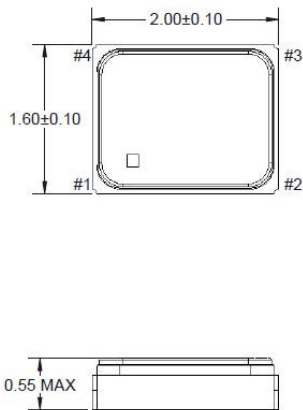

Pad layout -mm

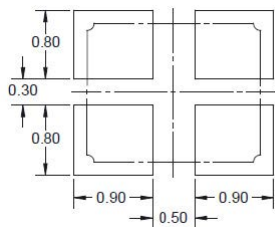

Function diagram

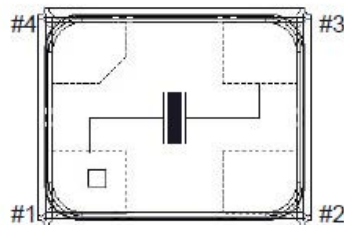

Pad	Function
1	In / out
2	Ground
3	Out / in
4	Ground

Tolerance unless otherwise specified: ±0.1 mm

Part marking

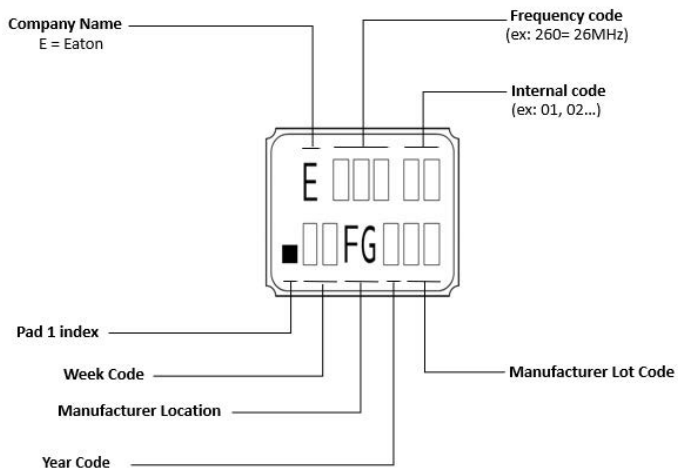

General specifications

Test item	According to	Test specification
Gross leak	MIL-STD-883 method 1014	Standard sample for automatic gross leak detector, test pressure: 2 kg/cm ²
Fine leak	MIL-STD-883 method 1014	Helium bombing 5.0 kg/cm ² for 2 hours
Drop test	JIS C6701	150 cm height, free fall onto stainless plate 3 times
Vibration	MIL-STD-202 method 201	Frequency range = 10 to 55 Hz Amplitude = 1.52 mm Test time of each perpendicular axis = 2 hours (x, y, z axis) Total test time = 6 hours
Mechanical shock	MIL-STD-202 method 213	Half sine wave, 1000 g, 0.5 ms duration along three mutually perpendicular axes (±X, ±Y, and ±Z). Each direction for 3 shocks (total 18 shocks)
Resistance to soldering heat	MIL-STD-202 method 210	Test temperature: +260 °C ± 5 °C Test time: 10 seconds ± 1 second
Solderability	J-STD-002	Temperature: +245 °C ± 5 °C Immersing depth: 0.5 mm minimum Immersion time: 5 ± 1 seconds Flux: rosin resin methyl alcohol solvent (1:4)
High temperature storage	MIL-STD-202 method 108	+125 °C ± 3 °C for 500 hours
Low temperature storage	IEC 60068-2-1	-40 °C ± 3 °C for 500 hours
Thermal shock	MIL-STD-883 method 1011.9	Total 100 cycles of the following temperature cycle.
High temperature & humidity	JIS C5023	+85 °C ± 3 °C, RH 85%, 500 hours
High temperature operating life	MIL-STD-202 method 108	1000 hours at +85 °C with VDD applied

Packaging information - mm

3,000 parts on a 7 inch tape and reel (Drawing not to scale)

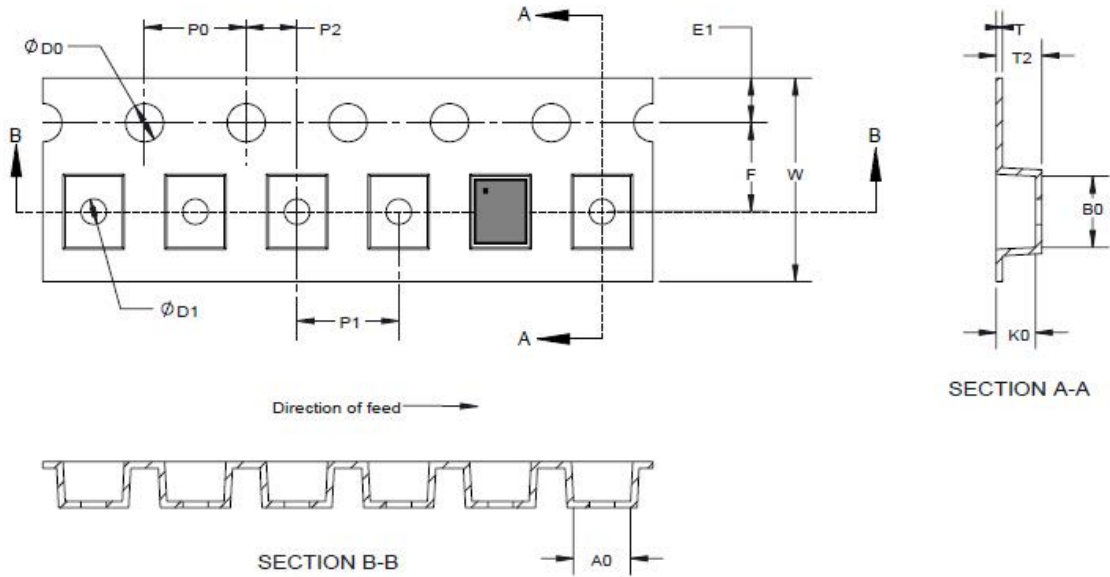

Dimension	Millimeter
W	8.00 ± 0.30
F	3.50 ± 0.05
E1	1.75 ± 0.10
P0	4.00 ± 0.10
P1	4.00 ± 0.10
P2	2.00 ± 0.05
D0	1.55 ± 0.05
D1	1.00 minimum
A0	1.90 ± 0.10
B0	2.30 ± 0.10
K0	0.65 ± 0.10
T	0.25 ± 0.05
T2	1.15 maximum

Solder reflow profile

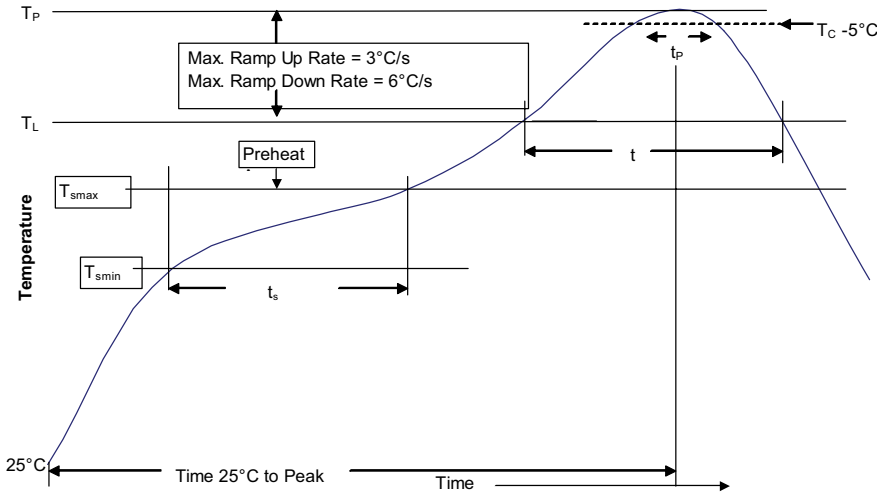

Table 1 - Standard SnPb solder (T_C)

Package thickness	Volume mm ³ <350	Volume mm ³ ≥350
<2.5 mm	235 °C	220 °C
≥2.5 mm	220 °C	220 °C

Table 2 - Lead (Pb) free solder (T_C)

Package thickness	Volume mm ³ <350	Volume mm ³ 350 - 2000	Volume mm ³ >2000
<1.6 mm	260 °C	260 °C	260 °C
1.6 – 2.5 mm	260 °C	250 °C	245 °C
>2.5 mm	250 °C	245 °C	245 °C

Reference J-STD-020

Profile feature	Standard SnPb solder	Lead (Pb) free solder
Preheat and soak	<ul style="list-style-type: none"> Temperature min. (T_{smin}) Temperature max. (T_{smax}) Time (T_{smin} to T_{smax}) (t_s) 	<ul style="list-style-type: none"> 100 °C 150 °C 60-120 seconds
Ramp up rate T _L to T _p	3 °C/ second max.	3 °C/ second max.
Liquidous temperature (T _L) Time (t _L) maintained above T _L	183 °C 60-150 seconds	217 °C 60-150 seconds
Peak package body temperature (T _p)*	Table 1	Table 2
Time (t _p)* within 5 °C of the specified classification temperature (T _C)	20 seconds*	30 seconds*
Ramp-down rate (T _p to T _L)	6 °C/ second max.	6 °C/ second max.
Time 25 °C to peak temperature	6 minutes max.	8 minutes max.

* Tolerance for peak profile temperature (T_p) is defined as a supplier minimum and a user maximum.

Manual solder

+350 °C maximum, 4 seconds maximum by soldering iron, 2 times maximum, generally manual, hand soldering is not recommended

Life Support Policy: Eaton does not authorize the use of any of its products for use in life support devices or systems without the express written approval of an officer of the Company. Life support systems are devices which support or sustain life, and whose failure to perform, when properly used in accordance with instructions for use provided in the labeling, can be reasonably expected to result in significant injury to the user.

Eaton reserves the right, without notice, to change design or construction of any products and to discontinue or limit distribution of any products. Eaton also reserves the right to change or update, without notice, any technical information contained in this bulletin.

Eaton
Electronics Division
1000 Eaton Boulevard
Cleveland, OH 44122
United States
Eaton.com/electronics



Singel 3 | B-2550 Kontich | Belgium | Tel.+32(0)3 458 30 33
info@alcom.be | www.alcom.be
Rivium 1e straat 52 | 2909 LE Capelle aan den IJssel | The Netherlands
Tel.+31(0)10 288 25 00 | info@alcom.nl | www.alcom.nl



© 2023 Eaton
All Rights Reserved
Printed in USA
Publication No. ELX1389 BU-ELX22257
November 2023

Eaton is a registered trademark.
All other trademarks are property of their respective owners.

Follow us on social media to get the latest product and support information.

