



GW2AR series of FPGA Products

Data Sheet

DS226-1.9.1E, 05/28/2021

Copyright©2021 Guangdong Gowin Semiconductor Corporation. All Rights Reserved.

GOWIN, Gowin, and GOWINSEMI are trademarks of Guangdong Gowin Semiconductor Corporation and are registered in China, the U.S. Patent and Trademark Office, and other countries. All other words and logos identified as trademarks or service marks are the property of their respective holders. No part of this document may be reproduced or transmitted in any form or by any denotes, electronic, mechanical, photocopying, recording or otherwise, without the prior written consent of GOWINSEMI.

Disclaimer

GOWINSEMI[®], LittleBee[®], Arora, and the GOWINSEMI logos are trademarks of GOWINSEMI and are registered in China, the U.S. Patent and Trademark Office and other countries. All other words and logos identified as trademarks or service marks are the property of their respective holders, as described at www.gowinsemi.com.cn. GOWINSEMI assumes no liability and provides no warranty (either expressed or implied) and is not responsible for any damage incurred to your hardware, software, data, or property resulting from usage of the materials or intellectual property except as outlined in the GOWINSEMI Terms and Conditions of Sale. All information in this document should be treated as preliminary. GOWINSEMI may make changes to this document at any time without prior notice. Anyone relying on this documentation should contact GOWINSEMI for the current documentation and errata.

Revision History

Date	Version	Description
05/11/2018	1.1E	Initial version published.
08/01/2018	1.2E	<ul style="list-style-type: none">• PLL Structure diagram updated;• The description of the SystemIO status for blank chips updated.
09/10/2018	1.3E	V _{CCO2/6/7} and V _{CCX} of GW2AR-18 QN88 with SDRAM embedded are internal short circuited.
11/12/2018	1.4E	<ul style="list-style-type: none">• PSRAM added;• GW2AR-18 QN88 and EQ144 with PSRAM added;• Part Name updated.
01/09/2019	1.5E	Reference manuals for memories updated.
04/01/2019	1.6E	<ul style="list-style-type: none">• Changed the operating temperature (Industrial) to junction temperature;• The package of EQ176 added.
11/12/2019	1.7E	<ul style="list-style-type: none">• Number of Max. I/O updated;• The package size of LQ144/EQL144/LQ176/EQ176 fixed;• IODELAY description updated.
03/10/2020	1.8E	Bit width and capacity of GW2AR-18 added.
06/19/2020	1.8.1E	<ul style="list-style-type: none">• Package name optimized;• Figures of part name optimized.
08/07/2020	1.9E	QN88PF and EQ144PF added.
05/28/2021	1.9.1E	PG256S added.

Contents

Contents	i
List of Figures	iv
List of Tables	vi
1 About This Guide	1
1.1 Purpose	1
1.2 Related Documents	1
1.3 Abbreviations and Terminology	1
1.4 Support and Feedback	2
2 General Description	3
2.1 Features	3
2.2 Product Resources	4
3 Architecture	6
3.1 Architecture Overview	6
3.2 Memory	7
3.2.1 SDR SDRAM	7
3.2.2 DDR SDRAM	8
3.2.3 PSRAM	9
3.3 Configurable Function Unit	10
3.3.1 CLU	10
3.3.2 CRU	12
3.4 IOB	12
3.4.1 I/O Buffer	13
3.4.2 I/O Logic	18
3.4.3 I/O Logic Modes	20
3.5 Block SRAM (BSRAM)	25
3.5.1 Introduction	25
3.5.2 Configuration Mode	27
3.5.3 Mixed Data Bus Width Configuration	29
3.5.4 Byte-enable	29
3.5.5 Parity Bit	29

3.5.6 Synchronous operation.....	30
3.5.7 Power up Conditions	30
3.5.8 BSRAM Operation Modes	30
3.5.9 Clock Operations	31
3.6 DSP.....	33
3.6.1 Introduction	33
3.6.2 DSP Operations.....	36
3.7 Clock.....	36
3.7.1 Global Clock	37
3.7.2 PLL	40
3.7.3 HCLK	42
3.7.4 DDR Memory Interface Clock Management DQS.....	42
3.8 Long Wire (LW).....	43
3.9 Global Set/Reset (GSR)	43
3.10 Programming Configuration.....	43
3.11 On Chip Oscillator	44
4 AC/DC Characteristics.....	45
4.1 Operating Conditions	45
4.1.1 Absolute Max. Ratings.....	45
4.1.2 Recommended Operating Conditions	45
4.1.3 Power Supply Ramp Rates	46
4.1.4 Hot Socket Specifications	46
4.1.5 POR Specifications.....	46
4.2 ESD.....	46
4.3 DC Electrical Characteristics	47
4.3.1 DC Electrical Characteristics over Recommended Operating Conditions	47
4.3.2 Static Supply Current.....	48
4.3.3 Recommended I/O Operating Conditions	49
4.3.4 IOB Single - Ended DC Electrical Characteristics.....	50
4.3.5 I/O Differential Electrical Characteristics	51
4.4 AC Switching Characteristics.....	51
4.4.1 CFU Switching Characteristics	51
4.4.2 BSRAM Switching Characteristic	51
4.4.3 DSP Switching Characteristics	52
4.4.4 External Switching Characteristics	52
4.4.5 On chip Oscillator Output Frequency	52
4.4.6 PLL Switching Characteristic.....	52
4.5 Configuration Interface Timing Specification	53
5 Ordering Information.....	54

5.1 Part Name.....	54
5.2 Package Mark.....	55



List of Figures

Figure 3-1 Architecture Diagram	6
Figure 3-2 CFU Structure.....	10
Figure 3-3 Register in CLS	11
Figure 3-4 IOB Structure View	13
Figure 3-5 GW2AR I/O Bank Distribution	14
Figure 3-6 I/O Logic Input	18
Figure 3-7 I/O Logic Input	18
Figure 3-8 IODELAY	19
Figure 3-9 Register Structure in I/O Logic	19
Figure 3-10 IEM Structure.....	19
Figure 3-11 I/O Logic in Basic Mode.....	20
Figure 3-12 I/O Logic in SDR Mode.....	21
Figure 3-13 I/O Logic in DDR Input Mode	21
Figure 3-14 I/O Logic in DDR Output Mode.....	21
Figure 3-15 I/O Logic in IDES4 Mode	22
Figure 3-16 I/O Logic in OSER4 Mode	22
Figure 3-17 I/O Logic in IVideo Mode	22
Figure 3-18 I/O Logic in OVideo Mode	23
Figure 3-19 I/O Logic in IDES8 Mode	23
Figure 3-20 I/O Logic in OSER8 Mode	23
Figure 3-21 I/O Logic in IDES10 Mode.....	23
Figure 3-22 I/O Logic in OSER10 Mode.....	24
Figure 3-23 I/O Logic in IDDR_MEM Mode	24
Figure 3-24 I/O Logic in ODDR_MEM Mode	24
Figure 3-25 I/O Logic in IDES4_MEM Mode	25
Figure 3-26 I/O Logic in OSER4_MEM Mode.....	25
Figure 3-27 I/O Logic in IDES8_MEM Mode	25
Figure 3-28 I/O Logic in OSER8_MEM Mode.....	25
Figure 3-29 Pipeline Mode in Single Port, Dual Port and Semi-Dual Port	30
Figure 3-30 Independent Clock Mode	32
Figure 3-31 Read/Write Clock Mode.....	32
Figure 3-32 Single Port Clock Mode.....	32

Figure 3-33 DSP Macro	34
Figure 3-34 GW2AR Clock Resources	37
Figure 3-35 GCLK Quadrant Distribution.....	38
Figure 3-36 DQCE Concept.....	39
Figure 3-37 DCS Concept.....	39
Figure 3-38 DCS Rising Edge.....	39
Figure 3-39 DCS Falling Edge	40
Figure 3-40 PLL Structure.....	40
Figure 3-41 GW2AR HCLK Distribution.....	42
Figure 3-42 DQS	43
Figure 5-1 Part Naming of Devices with SDRAM Embedded–ES	54
Figure 5-2 Part Naming of Devices with PSRAM Embedded–Production.....	55
Figure 5-3 Package Mark.....	55

List of Tables

Table 1-1 Abbreviations and Terminology	1
Table 2-1 Product Resources.....	4
Table 2-2 GW2AR-18 Devices	5
Table 2-3 Package Information and Max. I/O	5
Table 3-1 Register Description in CFU	12
Table 3-2 Output I/O Standards and Configuration Options	15
Table 3-3 Input I/O Standards and Configuration Options.....	17
Table 3-4 BSRAM Signals.....	27
Table 3-5 Memory Size Configurations	27
Table 3-6 Dual Port Mixed Read/Write Data Width Configuration	29
Table 3-7 Semi Dual Port Mixed Read/Write Data Width Configuration.....	29
Table 3-8 Clock Operations in Different BSRAM Modes	31
Table 3-9 DSP Ports Description	34
Table 3-10 Internal Registers Description	35
Table 3-11 Definition of the PLL Ports.....	41
Table 3-12 Oscillator Output Frequency Options.....	44
Table 4-1 Absolute Max. Ratings	45
Table 4-2 Recommended Operating Conditions.....	45
Table 4-3 Power Supply Ramp Rates	46
Table 4-4 Hot Socket Specifications	46
Table 4-5 POR Specifications	46
Table 4-6 GW2AR ESD - HBM	46
Table 4-7 GW2AR ESD - CDM	46
Table 4-8 DC Electrical Characteristics over Recommended Operating Conditions.....	47
Table 4-9 Static Supply Current	48
Table 4-10 Recommended I/O Operating Conditions	49
Table 4-11 IOB Single - Ended DC Electrical Characteristics	50
Table 4-12 I/O Differential Electrical Characteristics.....	51
Table 4-13 CFU Block Internal Timing Parameters.....	51
Table 4-14 BSRAM Internal Timing Parameters.....	51
Table 4-15 DSP Internal Timing Parameters	52
Table 4-16 External Switching Characteristics.....	52

Table 4-17 On chip Oscillator Output Frequency 52
Table 4-18 PLL Switching Characteristic 52



1 About This Guide

1.1 Purpose

This data sheet describes the features, product resources and structure, AC/DC characteristics, timing specifications of the configuration interface, and the ordering information of the GW2AR series of the FPGA products, which helps you to understand the GW2AR series of the FPGA products quickly and select and use devices appropriately.

1.2 Related Documents

The latest user guides are available on GOWINSEMI Website. You can find the related documents at www.gowinsemi.com:

1. [DS226, GW2AR series of FPGA Products Data Sheet](#)
2. [UG290, Gowin FPGA Products Programming and Configuration User Guide](#)
3. [UG229, GW2AR series of FPGA Products Package and Pinout](#)
4. [UG115, GW2AR-18 Pinout](#)

1.3 Abbreviations and Terminology

The abbreviations and terminologies used in this manual are set out in Table 1-1 below.

Table 1-1 Abbreviations and Terminology

Abbreviations and Terminology	Name
FPGA	Field Programmable Gate Array
SIP	System in Package
SDRAM	Synchronous Dynamic RAM
CFU	Configurable Function Unit
CLS	Configurable Logic Section
CRU	Configurable Routing Unit
LUT4	4-input Look-up Tables
LUT5	5-input Look-up Tables

Abbreviations and Terminology	Name
LUT6	6-input Look-up Tables
LUT7	7-input Look-up Tables
LUT8	8-input Look-up Tables
REG	Register
ALU	Arithmetic Logic Unit
IOB	Input/Output Block
SSRAM	Shadow Static Random Access Memory
BSRAM	Block Static Random Access Memory
SP	Single Port 16K BSRAM
SDP	Semi Dual Port 16K BSRAM
DP	True Dual Port 16K BSRAM
DSP	Digital Signal Processing
TDM	Time Division Multiplexing
DQCE	Dynamic Quadrant Clock Enable
DCS	Dynamic Clock Selector
PLL	Phase-locked Loop
GPIO	Gowin Programmable IO
CS	WLCSP, Wafer-Level Chip Scale Package
MG	MBGA, Micro Ball Grid Array Package
LQ	LQFP, Low-profile Quad Flat Package
EQ	ELQFP, E-pad Low-profile Quad Flat Package
PG	PBGA, Plastic Ball Grid Array Package
UG	UBGA, Ultra Ball Grid Array Package
QN	QFN, Quad Flat No-lead

1.4 Support and Feedback

Gowin Semiconductor provides customers with comprehensive technical support. If you have any questions, comments, or suggestions, please feel free to contact us directly using the information provided below.

Website: www.gowinsemi.com

E-mail: support@gowinsemi.com

2 General Description

GW2AR series FPGA products are the first generation of Arora[®] family products, and they are one kind of SIP chip. Compared with GW2A series, the difference is that GW2AR series integrates abundant SDRAM. GW2AR series also provides high-performance DSP resources, high-speed LVDS interface, and abundant BSRAM memory resources. These embedded resources with a streamlined FPGA architecture and 55nm process make GW2AR series FPGA products suitable for high-speed and low-cost applications.

GOWINSEMI provides a new generation of FPGA hardware development environment through the market-oriented independent research and development. This supports GW2AR series FPGA products and applies to FPGA synthesizing, layout, place and routing, data bitstream generation and download, etc.

2.1 Features

- Lower power consumption
 - 55nm SRAM technology
 - Core voltage: 1.0V
 - Clock dynamically turns on and off
- Integrate SDRAM system in package chip
- Multiple I/O standards
 - LVCMOS33/25/18/15/12; LVTTTL33, SSTL33/25/18 I, II, SSTL15; HSTL18 I, II, HSTL15 I; PCI, LVDS25, RSDS, LVDS25E, BLVDSE MLVDSE, LVPECLE, RSDSE
 - Input hysteresis option
 - Supports 4mA, 8mA, 16mA, 24mA, etc. drive options
 - Slew rate option
 - Output drive strength option
 - Individual bus keeper, weak pull-up, weak pull-down, and open drain option
 - Hot socket
- High performance DSP
 - High performance digital signal processing ability
 - Supports 9 x 9, 18 x 18, 36 x 36 bits multiplier and 54 bits

- accumulator;
- Multipliers cascading
- Registers pipeline and bypass
- Adaptive filtering through signal feedback
- Supports barrel shifter
- Abundant slices
 - Four input LUT (LUT4)
 - Double-edge flip-flops
 - Supports shift register and distributed register
- Block SRAM with multiple modes
 - Supports dual port, single port, and semi-dual port
 - Supports bytes write enable
- Flexible PLLs
 - Frequency adjustment (multiply and division) and phase adjustment
 - Supports global clock
- Configuration
 - JTAG configuration
 - Four GowinCONFIG configuration modes: AUTOBOOT, SSPI, MSPI, CPU, SERIAL, DUAL BOOT
 - Data stream file encryption and security bit settings

2.2 Product Resources

Table 2-1 Product Resources

Device	GW2AR-18
LUT4	20,736
Flip-Flop (FF)	15,552
Shadow SRAM SSRAM (bits)	41,472
Block SRAM BSRAM (bits)	828K
BSRAM quantity BSRAM	46
SDR/DDR SDRAM (bits)	64M / 128M
PSRAM (bits)	64M
18 x 18 Multiplier	48
Maximum ¹ (PLLs)	4
Total number of I/O banks	8
Max. I/O	384
Core voltage	1.0V

Note!

[1] Different packages support different numbers of PLLs; up to four PLLs can be supported.

Table 2-2 GW2AR-18 Devices

Package	Device	Memory	Bit Width	Capacity	Available PLL
LQ144 ^[1]	GW2AR-18	SDR SDRAM	32 bits	64M bits	PLLL0/PLLL1/PLLR0/PLLR1
EQ144 ^[1]	GW2AR-18	SDR SDRAM	32 bits	64M bits	
EQ144P ^{[1][2]}	GW2AR-18	PSRAM	16 bits	64M bits	
EQ144PF ^{[1][2]}	GW2AR-18	PSRAM	16 bits	64M bits	
PG256S	GW2AR-18	SDR SDRAM	32 bits	64M bits	
QN88	GW2AR-18	SDR SDRAM	32 bits	64M bits	PLLL1/ PLLR1
QN88P ^[2]	GW2AR-18	PSRAM	16 bits	64M bits	
QN88PF ^[2]	GW2AR-18	PSRAM	16 bits	64M bits	
LQ176	GW2AR-18	DDR SDRAM	16 bits	128M bits	PLLL1/PLLR0/PLLR1
EQ176	GW2AR-18	DDR SDRAM	16 bits	128M bits	

Note!

- [1] V_{CCPLL1} and V_{CC} of LQ144/EQ144 / EQ144P / EQ144PF package are internal short circuited. Please refer to Table 4-2 for details.
- [2] "P" indicates PSRAM; "F" indicates secondary pinout.

Table 2-3 Package Information and Max. I/O

Package	Pitch (mm)	Size (mm)	E-pad Size (mm)	GW2AR-18
LQ144	0.5	20 x 20	-	120(35)
EQ144	0.5	20 x 20	9.74 x 9.74	120(35)
EQ144P	0.5	20 x 20	9.74 x 9.74	120(35)
EQ144PF	0.5	20 x 20	9.74 x 9.74	120(35)
QN88	0.4	10 x 10	6.74 x 6.74	66(22)
QN88P	0.4	10 x 10	6.74 x 6.74	66(22)
QN88PF	0.4	10 x 10	6.74 x 6.74	66(22)
LQ176	0.4	20 x 20	-	140(45)
EQ176	0.4	20 x 20	6 x 6	140(45)
PG256S	1.0	17 x 17	-	192(62)

Note!

- [1] The package types in this data sheet are written with abbreviations. See 5.1 Part Name.
- JTAGSEL_N and JTAG pins cannot be used as I/O simultaneously. The Max. I/O noted in this table is referred to when the four JTAG pins (TCK, TDI, TDO, and TMS) are used as I/O. When mode [2:0] = 001, JTAGSEL_N and the four JTAG pins (TCK, TDI, TDO, and TMS) can be used as GPIO simultaneously, and the Max. user I/O is increased by one. See [UG229, GW2AR series of FPGA Products Package and Pinout Manual](#) for more details.

3 Architecture

3.1 Architecture Overview

Figure 3-1 Architecture Diagram

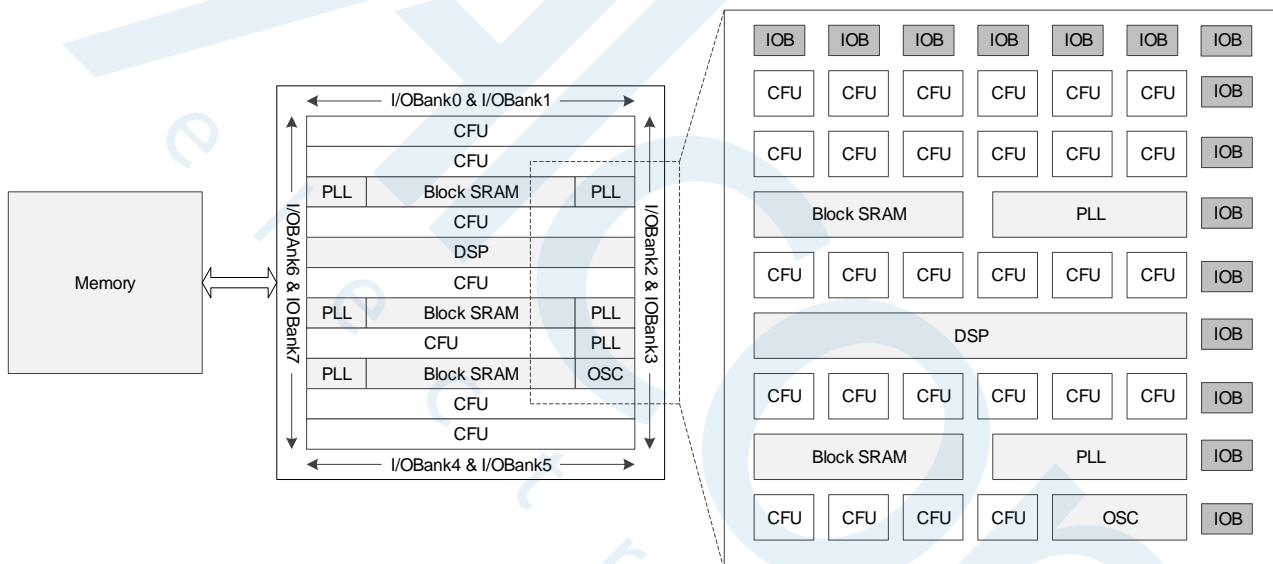

Figure 3-1 shows the architecture diagram of GW2AR series FPGA products, and GW2AR is a system in package chip (SIP), integrated with GOWINSEMI GW2A series FPGA products and SDRAM chip. For SDRAM chip features and overview, see [3.2 Memory](#).

For the internal resource info. of GW2AR, please refer to Table 2-1. The core of device is an array of Logic Unit surrounded by IO blocks. Besides, GW2AR provides BSRAM, DSP, PLL, and on chip oscillator.

Configurable Function Unit (CFU) is the base cell for the array of GW2AR series FPGA Products. Devices with different capacities have different numbers of rows and columns. CFU can be configured as LUT4 mode, ALU mode, and memory mode. For more detailed information, see [3.3 Configurable Function Unit](#).

The I/O resources in GW2AR series FPGA products are arranged around the periphery of the devices in groups referred to as banks, which

are divided into eight Banks, including Bank0 ~ Bank7. I/O resources support multiple I/O standards, and support regular mode, SRD mode, generic DDR mode, and DDR_MEM mode. For more detailed information, see [3.4 IOB](#).

The BSRAM is embedded as row in GW2AR series FPGA products. Each BSRAM has 18,432 bits (18 Kbits) and supports multiple configuration modes and operation modes. For more detailed information, see [3.5 Block SRAM \(BSRAM\)](#).

GW2AR series FPGA products have built-in DSPs. DSP blocks are embedded as a row in the FPGA array. Each DSP block contains two Macros, and each Macro contains two pre-adders, two multipliers with 18 by 18 inputs, and a three input ALU54. For more detailed information, see [3.6 DSP](#).

GW2AR provides one PLL. PLL blocks provide the ability to synthesize clock frequencies. Frequency adjustment (multiply and division), phase adjustment, and duty cycle can be adjusted using the configuration of parameters. There is an internal programmable on-chip oscillator in each of the GW2AR series of the FPGA product. The on-chip oscillator supports the clock frequencies ranging from 2.5 MHz to 125 MHz, providing the clock resource for the MSPI mode. It also provides a clock resource for user designs with the clock precision reaching $\pm 5\%$. For more detailed information, see [3.7 Clock](#), [3.11 On Chip Oscillator](#).

FPGA provides abundant CRUs, connecting all the resources in the FPGA. For example, routing resources distributed in CFU and IOB connect resources in CFU and IOB. Routing resources can be generated by Gowin YunYuan software automatically. In addition, the GW2AR series of FPGA Products also provide abundant GCLKs, long wires (LW), global set/reset (GSR), and programming options, etc. For more detailed information, see [3.7 Clock](#), [3.8 Long Wire \(LW\)](#), and [3.9 Global Set/Reset \(GSR\)](#).

3.2 Memory

Different packages for the GW2AR series of FPGA products have different memory capacities and types. Please refer to [2.2](#) for details.

3.2.1 SDR SDRAM

Features

- Access time: 5.4 ns/5.4 ns
- Clock frequency: 166 MHz
- Data width: 32bits
- Capacity: 64M bits
- Synchronous operation
- Internal pipeline architecture
- Four internal banks (512K x 32 bits x 4bank)
- Programmable mode
 - Column address strobe latency: 2 or 3
 - Burst length: 1, 2, 4, 8 bytes or full page
 - Burst type: sequential mode or interval mode
 - Burst-Read-Single-Write

- Burst stop function
- Byte masking function
- Auto refresh and self refresh
- 4,096 refresh cycle / 64ms
- 3.3V ± 0.3V power supply¹
- LVTTTL Interface

Note!

For the more detailed information about power supply, please refer to Table 4-2.

Overview

The SDR SDRAM that is integrated into the GW2AR series of FPGA products is a high-speed CMOS synchronous DRAM with a capacity of 64 Mbits. The SDRAM consists of four banks. Each BANK size is 512K x32 bits, and each BANK consists of 2,048 rows x 256 columns x 32 bits of memory arrays. The SDRAM supports read-write operation burst mode; accesses start at a selected location and continues for a programmed number of locations in a programmed sequence. The activation command is a must before reading or writing. Read or write burst lengths provide 1, 2, 4, and 8 bytes or full page, with a burst termination option. An auto pre-charge function may be enabled to provide a self-timed row pre-charge that is initiated at the end of the burst sequence. Both the auto- or self-refresh functions are easy to use. Through the use of a programmable mode register, the system can choose the most suitable modes to maximize its performance.

The power supply for the SDR SDRAM interface is 3.3V; the BANK voltage connects to SDR SDRAM needs to be 3.3V. Please refer to [4 AC/DC Characteristics>4.1 Operating Conditions>Table 4-2](#) for further details.

The IP Core Generator that is integrated into GOWINSEMI YunYuan Software supports both built-in and external SDR SDRAM controller IP. This controller IP can be used for the SDRAM power-up, initialization, read calibration, etc., by following the controller read/write timing. For the further detailed information, please refer to [IPUG279, Gowin SDRAM Controller User Guide](#).

3.2.2 DDR SDRAM

Features

- Clock frequency: 250MHz/200MHz
- Data width: 16bits
- Capacity: 128M bits
- Differential clock input CLK and ~CLK
- Duplexing DQS
- Synchronous operation
- Internal pipeline architecture
- Four Banks, and each BANK size is 2 M x 16 bits
- Programming mode and extension mode register
 - Column Address Strobe Latency: 2, 2.5, 3
 - Burst length: 2, 4, 8

- Burst type: Sequential mode or interval mode
- Byte masking function
- DM write delay is 0
- Auto-refresh and self-refresh
- 4,096 refresh cycle / 64ms
- Pre-charge and power down activation
- $2.5V \pm 0.2V$ power supply¹
- SSTL_2 interface

Note!

For the more detailed information about power supply, please refer to Table 4-2.

Overview

The DDR SDRAM that is integrated in the GW2AR series of FPGA products is a high-speed CMOS double edge data sampling DRAM with a capacity of 128 Mbits. There are four BANKs, each of which is 2 M x 16 bits. All inputs employ clock rising edge as a reference; the data is read at clock rising edge and falling edge. The DDR SDRAM supports read-write operation burst mode; accesses start at a selected location and continue for a programmed number of locations in a programmed sequence. The activation command must be executed before reading or writing. Read and write burst lengths are 1, 2, 4, and 8 bytes. An auto pre-charge function may be enabled to provide a self-timed row pre-charge that is initiated at the end of the burst sequence. DDR SDRAM provides auto-refresh and self-refresh. The DDR SDRAM provides programming mode register and extension mode register. By having a programmable mode register, the system can choose the most suitable modes to maximize its performance.

The power supply for the DDR SDRAM interface is 2.5V; the BANK voltage that connects to the DDR SDRAM needs to be 2.5 V. Please refer to [4 AC/DC Characteristics>4.1 Operating Conditions>Table 4-2](#) for further details.

The IP Core Generator that is integrated into GOWINSEMI YunYuan Software supports both built-in and external DDR SDRAM controller IP. This controller IP can be used for the DDR power-up, initialization, read calibration, etc., by following the controller read/write timing. For the further detailed information, please refer to IPUG507, [Gowin DDR Memory Interface IP User Guide](#).

3.2.3 PSRAM**Features**

- Clock frequency: 166MHz, up to DDR332
- Double edge data transmission
- Data width:16bits
- Read/write data strobe (RWDS)
- Temperature compensated refresh
- Partial arrayself refresh (PASR)
- Hybrid sleep mode
- Deep power down (DPD)
- Drive Capability:35,50,100 and 200 Ohm

- Burst access
- 16/32/64/128 bytes burst mode
- Status/Control register
- 1.8V power supply¹

The power supply of the PSRAM interface is 1.8V. The BANK voltage that connects to the PSRAM needs to be 1.8V. For the further information, please refer to [4.1 Operating Conditions](#).

The IP Core Generator that is integrated into GOWINSEMI YunYuan Software supports both built-in and external PSRAM controller IP. This controller IP can be used for the PSRAM power-up, initialization, read calibration, etc., by following the controller read/write timing. For the further detailed information, please refer to [IPUG525, Gowin HyperRAM & PSRAM Memory Interface IP User Guide](#).

3.3 Configurable Function Unit

The configurable function unit (CFU) is the base cell for the array of the GW2AR series of FPGA Products. Each CFU consists of a configurable logic unit (CLU) and its routing resource configurable routing unit (CRU). In each CLU, there are four configurable logic slices (CLS). Each CLS contains look-up-tables (LUT) and registers, as shown in Figure 3-2 below.

Figure 3-2 CFU Structure

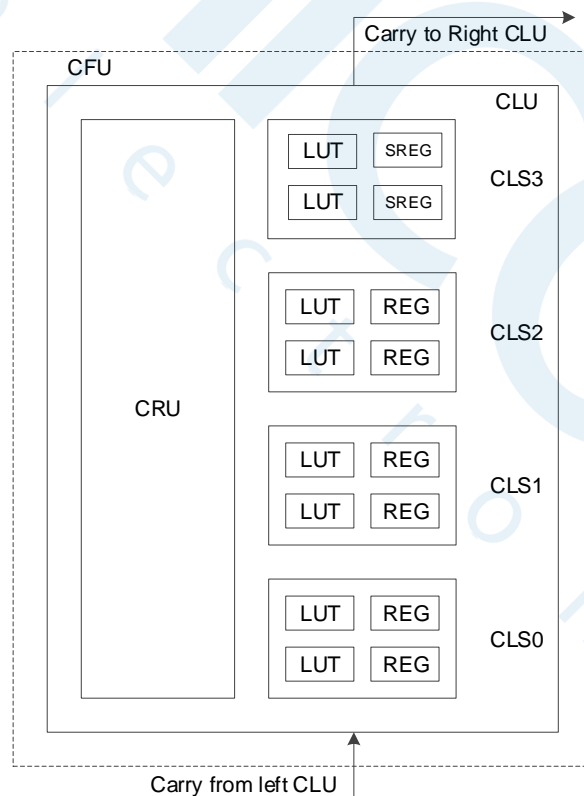

Note!

SERG needs special patch supporting. Please contact Gowin technical support or local Office for this patch.

3.3.1 CLU

The CLU supports three operation modes: Basic logic mode, ALU

mode, and memory mode.

- Basic Logic Mode

Each LUT can be configured as one four-input LUT. Higher input number of LUT can be formed by combining the LUT4 together.

- Each CLS can form one five-input LUT5.
- Two CLSs can form one six-input LUT6.
- Four CLSs can form one seven-input LUT7.
- Eight CLSs (two CLUs) can form one eight-input LUT8.

- ALU Mode

When combined with carry chain logic, the LUT can be configured as the ALU mode to implement the following functions.

- Adder and subtractor
- Up/down counter
- Comparator, including greater-than, less-than, and not-equal-to
- MULT

- Memory mode

In this mode, a 16 x 4 SSRAM or ROM can be constructed by using CLSs.

This SRAM can be initialized during the device configuration stage. The initialization data can be generated in the bit stream file from Gowin Yunyuan software.

Each configurable logic slice (CLS) has two registers (REG), as shown in Figure 3-3 below.

Figure 3-3 Register in CLS

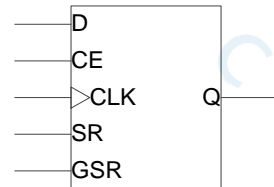

Table 3-1 Register Description in CFU

Signal	I/O	Description
D	I	Data input ¹
CE	I	CLK enable, can be high or low effective ²
CLK	I	Clock, can be rising edge or falling edge triggering ²
SR	I	Set/Reset, can be configured as ² : <ul style="list-style-type: none"> ● Synchronized reset ● Synchronized set ● Asynchronous reset ● Asynchronous set ● Non
GSR ^{3,4}	I	Global Set/Reset, can be configured as ⁴ : <ul style="list-style-type: none"> ● Asynchronous reset ● Asynchronous set ● Non
Q	O	Register

Note!

- [1] The source of the signal D can be the output of a LUT, or the input of the CRU; as such, the register can be used alone when LUTs are in use.
- [2] CE/CLK/SR in CFU is independent.
- [3] In the GW2AR series of FPGA products, GSR has its own dedicated network.
- [4] When both SR and GSR are effective, GSR has higher priority.

3.3.2 CRU

The main functions of the CRU are as follows:

- Input selection: Select input signals for the CFU.
- Configurable routing: Connect the input and output of the CFUs, including inside the CFU, CFU to CFU, and CFU to other functional blocks in FPGA.

3.4 IOB

The IOB in the GW2AR series of FPGA products includes IO buffer, IO logic, and its routing unit. As shown below, each IOB connects to two Pins (Marked as A and B). They can be used as a differential pair or as a single end input/output.

Figure 3-4 IOB Structure View

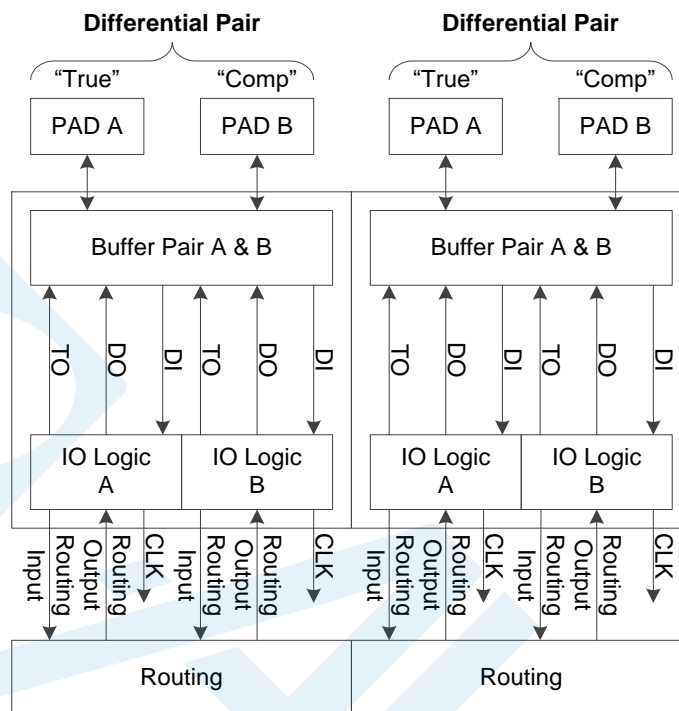

IOB Features:

- VCCO supplied with each bank
- LVCMOS, PCI, LVTTTL, LVDS, SSTL, and HSTL
- Input hysteresis option
- Output drive strength option
- Slew rate option
- Individual bus keeper, weak pull-up, weak pull-down, and open drain option
- Hot socket
- IO Logic supports basic mode, SRD mode, and generic DDR mode

For further information about IOB, please refer to [UG289, Gowin Programmable IO \(GPIO\) User Guide](#).

3.4.1 I/O Buffer

There are eight I/O Banks in the GW2AR series of FPGA products, as shown in Figure 3-5. Each Bank has independent IO source V_{CCO} . V_{CCO} can be 3.3V, 2.5V, 1.8V, 1.5V, or 1.2V. The auxiliary voltage of SDR SDRAM, V_{CCX} , and I/O BANK voltage, V_{CCO} , needs to be 3.3V. Please refer to [3.2.1SDR SDRAM](#) for further details. The auxiliary voltage of SDR SDRAM, V_{CCX} , and I/O BANK voltage, V_{CCO} , needs to be 2.5V. Please refer to [3.2.2DDR SDRAM](#) for details. To support SSTL, HSTL, etc., each bank also provides one independent voltage source (VREF) as reference voltage. The user can choose from the internal reference voltage of the bank ($0.5 \times V_{CCO}$) or the external reference voltage using any IO from the bank. V_{CCX} is 2.5V and 3.3V.

Figure 3-5 GW2AR I/O Bank Distribution

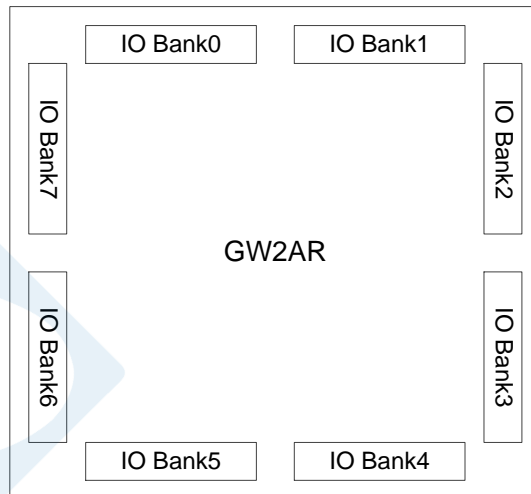

Different banks in the GW2AR series of FPGA Products support different on-chip resistor settings, including single-ended resistor and differential resistor. Single-ended resistor is set for SSTL/HSTL I/O and is supported in bank 2/3/6/7. Differential resistor is set for LVDS input and is only supported in Bank 0/1. Please refer to [UG289, Gowin Programmable IO User Guide](#) for more detailed information.

Note!

By default, the Gowin Programmable IO (GPIO) is tri-stated input weak pull-up.

For the V_{CCO} requirements of different I/O standards, see Table 3-2.

Table 3-2 Output I/O Standards and Configuration Options

I/O output standard	Single/Differ	Bank V _{CCO} (V)	Driver Strength (mA)	Hysteresis	Need V _{REF}
LVTTTL33	Single end	3.3	4,8,12,16,24	Yes	No
LVC MOS33	Single end	3.3	4,8,12,16,24	Yes	No
LVC MOS25	Single end	2.5	4,8,12,16	Yes	No
LVC MOS18	Single end	1.8	4,8,12	Yes	No
LVC MOS15	Single end	1.5	4,8	Yes	No
LVC MOS12	Single end	1.2	4,8	Yes	No
SSTL25_I	Single end	2.5	8	No	Yes
SSTL25_II	Single end	2.5	8	No	Yes
SSTL33_I	Single end	3.3	8	No	Yes
SSTL33_II	Single end	3.3	8	No	Yes
SSTL18_I	Single end	1.8	8	No	Yes
SSTL18_II	Single end	1.8	8	No	Yes
SSTL15	Single end	1.5	8	No	Yes
HSTL18_I	Single end	1.8	8	No	Yes
HSTL18_II	Single end	1.8	8	No	Yes
HSTL15_I	Single end	1.5	8	No	Yes
PCI33	Single end	3.3	N/A	Yes	No
LVPECL33E	Differential	3.3	16	No	No
MLVDS25E	Differential	2.5	16	No	No
BLVDS25E	Differential	2.5	16	No	No
RSDS25E	Differential	2.5	8	No	No
LVDS25E	Differential	2.5	8	No	No
LVDS25	Differential	2.5/3.3	3.5/2.5/2/1.25	No	No
RSDS	Differential	2.5/3.3	2	No	No
MINILVDS	Differential	2.5/3.3	2	No	No
PPLVDS	Differential	2.5/3.3	3.5	No	No
SSTL15D	Differential	1.5	8	No	No
SSTL25D_I	Differential	2.5	8	No	No
SSTL25D_II	Differential	2.5	8	No	No
SSTL33D_I	Differential	3.3	8	No	No
SSTL33D_II	Differential	3.3	8	No	No
SSTL18D_I	Differential	1.8	8	No	No
SSTL18D_II	Differential	1.8	8	No	No

I/O output standard	Single/Differ	Bank V _{CCO} (V)	Driver Strength (mA)	Hysteresis	Need V _{REF}
II					
HSTL18D_I	Differential	1.8	8	No	No
HSTL18D_II	Differential	1.8	8	No	No
HSTL15D_I	Differential	1.5	8	No	No

Table 3-3 Input I/O Standards and Configuration Options

I/O Input Standard	Single/Differ	Bank V _{CCO} (V)	Hysteresis	Need V _{REF}
LVTTTL33	Single end	1.5/1.8/2.5/3.3	Yes	No
LVC MOS33	Single end	1.5/1.8/2.5/3.3	Yes	No
LVC MOS25	Single end	1.5/1.8/2.5/3.3	Yes	No
LVC MOS18	Single end	1.5/1.8/2.5/3.3	Yes	No
LVC MOS15	Single end	1.2/1.5/1.8/2.5/3.3	Yes	No
LVC MOS12	Single end	1.2/1.5/1.8/2.5/3.3	Yes	No
SSTL15	Single end	1.5/1.8/2.5/3.3	No	Yes
SSTL25_I	Single end	2.5/3.3	No	Yes
SSTL25_II	Single end	2.5/3.3	No	Yes
SSTL33_I	Single end	3.3	No	Yes
SSTL33_II	Single end	3.3	No	Yes
SSTL18_I	Single end	1.8/2.5/3.3	No	Yes
SSTL18_II	Single end	1.8/2.5/3.3	No	Yes
HSTL18_I	Single end	1.8/2.5/3.3	No	Yes
HSTL18_II	Single end	1.8/2.5/3.3	No	Yes
HSTL15_I	Single end	1.5/1.8/2.5/3.3	No	Yes
PCI33	Single end	3.3	Yes	No
LVDS	Differential	2.5/3.3	No	No
RSDS	Differential	2.5/3.3	No	No
MINILVDS	Differential	2.5/3.3	No	No
PPLVDS	Differential	2.5/3.3	No	No
LVDS25E	Differential	2.5/3.3	No	No
MLVDS25E	Differential	2.5/3.3	No	No
BLVDS25E	Differential	2.5/3.3	No	No
RSDS25E	Differential	2.5/3.3	No	No
LVPECL33	Differential	3.3	No	No
SSTL15D	Differential	1.5/1.8/2.5/3.3	No	No
SSTL25D_I	Differential	2.5/3.3	No	No
SSTL25D_II	Differential	2.5/3.3	No	No
SSTL33D_I	Differential	3.3	No	No
SSTL33D_II	Differential	3.3	No	No
SSTL18D_I	Differential	1.8/2.5/3.3	No	No
SSTL18D_II	Differential	1.8/2.5/3.3	No	No
HSTL18D_I	Differential	1.8/2.5/3.3	No	No
HSTL18D_II	Differential	1.8/2.5/3.3	No	No
HSTL15D_I	Differential	1.5/1.8/2.5/3.3	No	No

3.4.2 I/O Logic

Figure 3-6 shows the I/O logic input of the GW2AR series of FPGA products.

Figure 3-6 I/O Logic Input

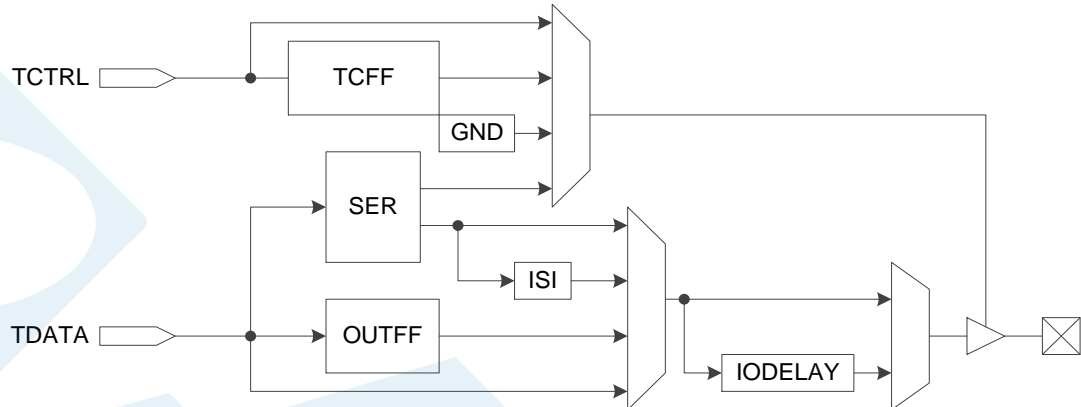
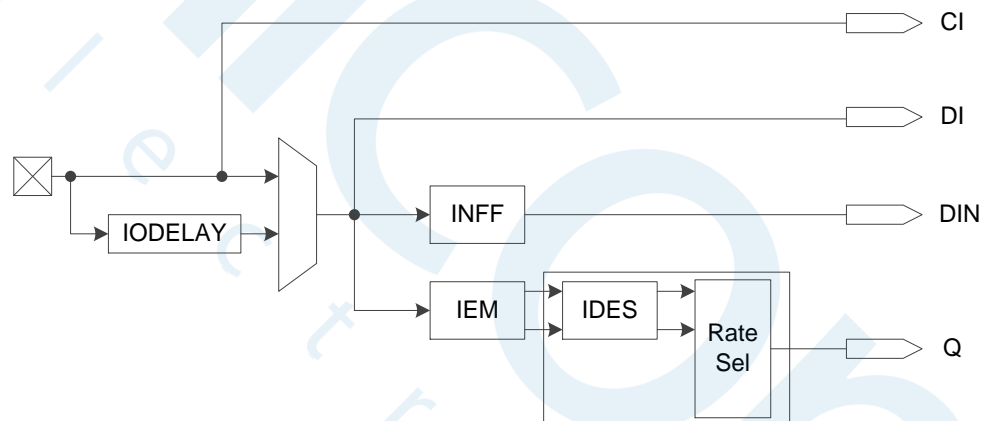

Figure 3-7 shows the I/O logic input of the GW2AR series of FPGA products.

Figure 3-7 I/O Logic Input



A description of the I/O logic modules of the GW2AR series of FPGA products is presented below.

IODELAY

See Figure 3-8 for an overview of the IODELAY. Each I/O of the GW2AR series of FPGA products has an IODELAY cell. A total of 128(0~127) step delay is provided, with one-step delay time of around 18ps.

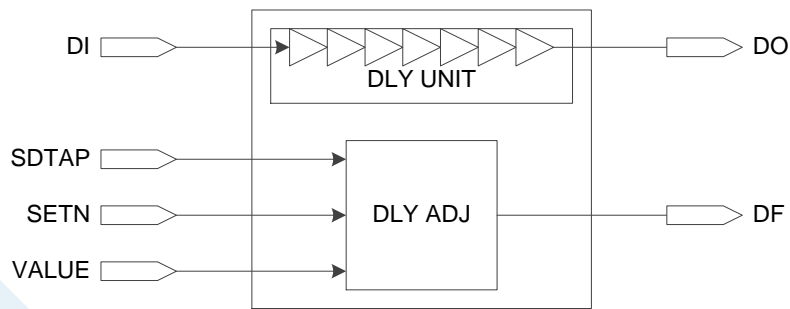
Figure 3-8 IODELAY

The delay cell can be controlled in two ways:

- Static control.
- Dynamic control: Usually used to sample delay window together with IEM. The IODELAY cannot be used for both input and output at the same time.

I/O Register

See Figure 3-9 for the I/O register in the GW2AR series of FPGA products. Each I/O provides one input register, INFF, one output register, OUTFF, and a tristate Register, TCFF.

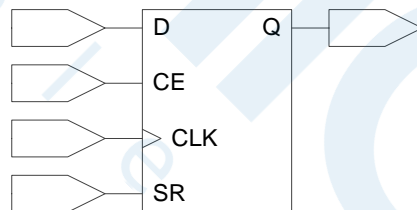
Figure 3-9 Register Structure in I/O Logic

Note!

- CE can be either active low (0: enable) or active high (1: enable).
- CLK can be either rising edge trigger or falling edge trigger.
- SR can be either synchronous/asynchronous SET or RESET or disable.
- The register can be programmed as register or latch.

IEM

IEM is for sampling clock edge and is used in the generic DDR mode, as shown in Figure 3-10.

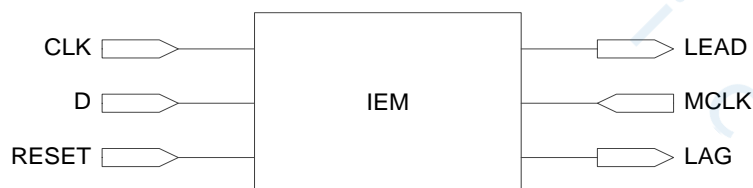
Figure 3-10 IEM Structure

De-serializer DES and Clock Domain Transfer

The GW2AR series of FPGA products provides a simple serializer

SER for each output I/O to support advanced I/O protocols. The clock domain transfer module of the input clock in DES provides the ability to safely switch the external sampling clock to the internal continuous running clock. Multiple registers used for data sampling.

The clock domain transfer module offers the following functions:

- The internal continuous clock is used instead of the discontinuous DQS for data sampling. The function is applied to the interface of the DDR memory.
- For the DDR3 memory interface standard, align the data after DQS read-leveling.
- In regular DDR mode, when DQS.RCLK is used for sampling, clock domain transfer module also needs to be used.

Each DQS provides WADDR and RADDR signals to the same group in the clock domain transfer module.

Serializer SER

The GW2AR series of FPGA products provides a simple serializer (SER) for each output I/O to support advanced I/O protocols.

3.4.3 I/O Logic Modes

The I/O Logic in the GW2AR series of FPGA products supports several modes. In each operation, the I/O (or I/O differential pair) can be configured as output, input, and INOUT or tristate output (output signal with tristate control).

Basic Mode

In basic mode, the I/O Logic is as shown in Figure 3-11, and the TC, DO, and DI signals can connect to the internal cores directly through CRU.

Figure 3-11 I/O Logic in Basic Mode

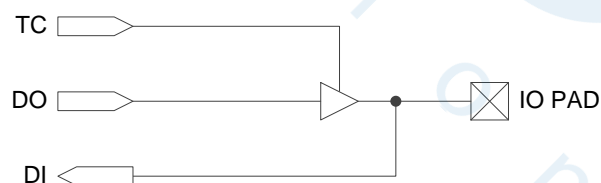

SDR Mode

In comparison with the basic mode, SDR utilizes the IO register, as shown in Figure 3-12. This can effectively improve IO timing.

Figure 3-12 I/O Logic in SDR Mode

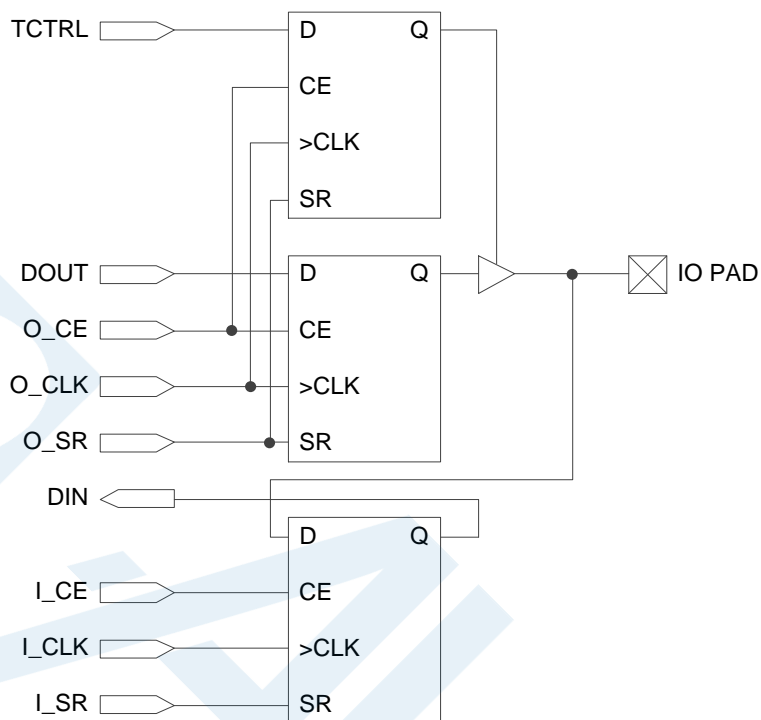

Note!

- CLK enable O_CE and I_CE can be configured as active-high or active-low.
- O_CLK and I_CLK can be either rising edge trigger or falling edge trigger.
- Local set/reset signal O_SR and I_SR can be synchronized reset, synchronized set, asynchronous reset, asynchronous set, or no-function.
- I/O in SDR mode can be configured as basic register or latch.

Generic DDR Mode

Higher speed I/O protocols can be supported in generic DDR mode.

Figure 3-13 shows the generic DDR input, with a speed ratio of the internal logic to PAD 1:2.

Figure 3-13 I/O Logic in DDR Input Mode



Figure 3-14 shows the generic DDR output, with a speed ratio of the PAD to FPGA internal logic 2:1.

Figure 3-14 I/O Logic in DDR Output Mode

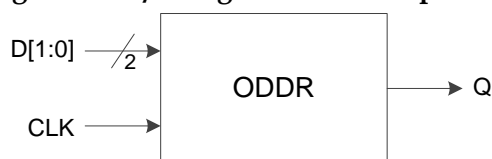

IDES4

In IDES4 mode, the speed ratio of the PAD to FPGA internal logic is 1:4.

Figure 3-15 I/O Logic in IDES4 Mode

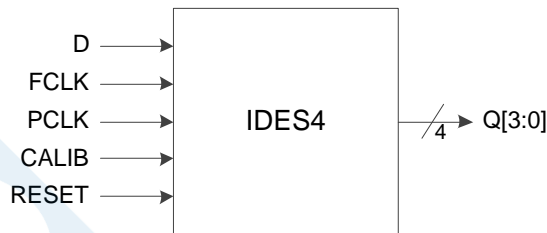

OSER4 Mode

In OSER4 mode, the speed ratio of the PAD to FPGA internal logic is 4:1.

Figure 3-16 I/O Logic in OSER4 Mode

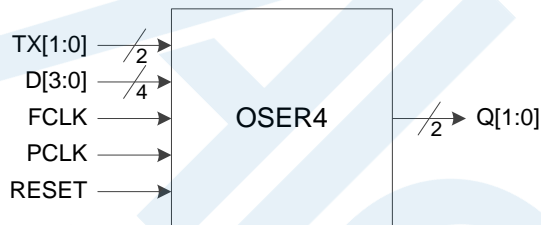

IVideo Mode

In IVideo mode, the speed ratio of the PAD to FPGA internal logic is 1:7.

Figure 3-17 I/O Logic in IVideo Mode



Note!

IVideo and IDES8/10 will occupy the neighboring I/O logic. If the I/O logic of a single port is occupied, the pin can only be programmed in SDR or BASIC mode.

OVideo Mode

In OVideo mode, the speed ratio of the PAD to FPGA internal logic is 7:1.

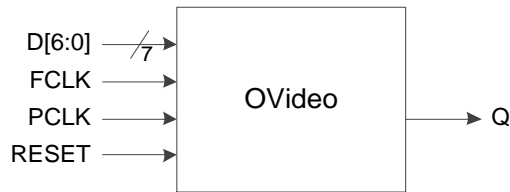
Figure 3-18 I/O Logic in OVideo Mode**IDES8 Mode**

In IDES8 mode, the speed ratio of the PAD to FPGA internal logic is 1:8.

Figure 3-19 I/O Logic in IDES8 Mode**OSER8 Mode**

In OSER8 mode, the speed ratio of the PAD to FPGA internal logic is 8:1.

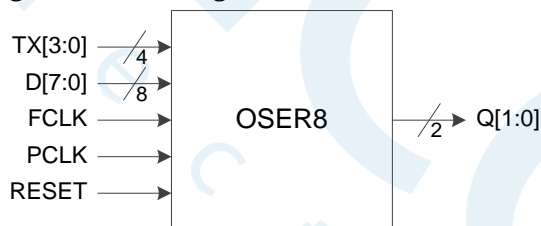
Figure 3-20 I/O Logic in OSER8 Mode**IDES10 Mode**

In IDES10 mode, the speed ratio of the PAD to FPGA internal logic is 1:10.

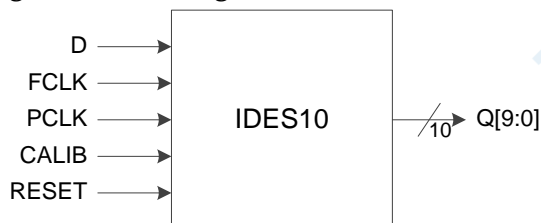
Figure 3-21 I/O Logic in IDES10 Mode**OSER10 Mode**

In OSER10 mode, the speed ratio of the PAD to FPGA internal logic is 10:1.

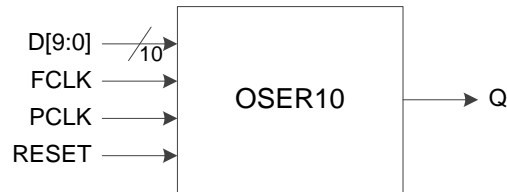
Figure 3-22 I/O Logic in OSER10 Mode

The GW2AR series of FPGA products supports IO interface modes with memory, supports double/four/eight speed rate input and output, including IDDR_MEM, IDES4_MEM, IDES8_MEM, ODDR_MEM, OSER4_MEM, and OSER8_MEM modes.

IDDR_MEM/IDES4_MEM/IDES8_MEM needs to be used with DQS. ICLK connects output signal DQSR90 of DQS and sends data to IO interfaces according to ICLK clock edge. WADDR [2: 0] connects output signal WPOINT of DQS; RADDR [2: 0] connects output signal RPOINT of DQS.

ODDR_MEM/OSER4_MEM/OSER8_MEM needs to be used with DQS. TCLK connects output signal DQSW0 or DQSW270 of DQS, and outputs data from IO interfaces according to TCLK clock edge.

IDDR_MEM Mode

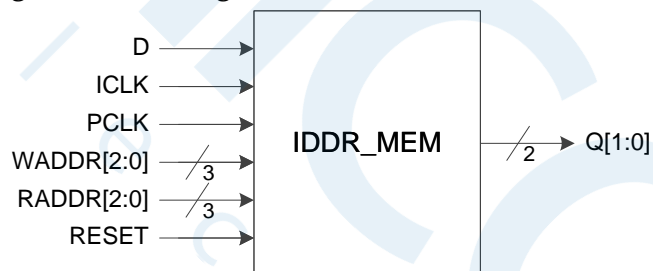
Figure 3-23 I/O Logic in IDDR_MEM Mode

ODDR_MEM Mode

Figure 3-24 I/O Logic in ODDR_MEM Mode

IDES4_MEM Mode

Figure 3-25 I/O Logic in IDES4_MEM Mode

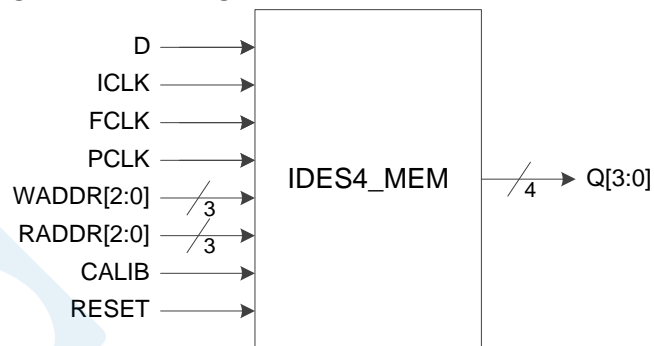

OSER4_MEM Mode

Figure 3-26 I/O Logic in OSER4_MEM Mode

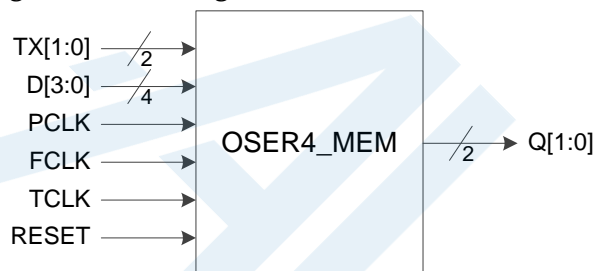

IDES8_MEM Mode

Figure 3-27 I/O Logic in IDES8_MEM Mode

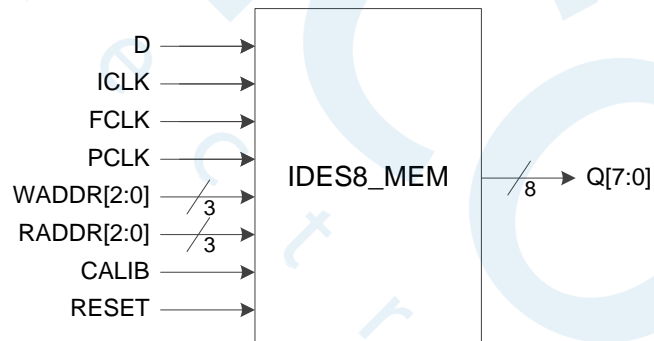

OSER8_MEM Mode

Figure 3-28 I/O Logic in OSER8_MEM Mode

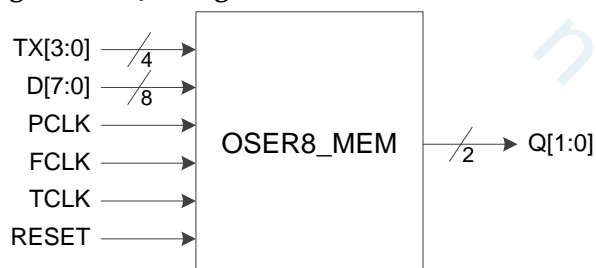

3.5 Block SRAM (BSRAM)

3.5.1 Introduction

The GW2AR series of FPGA products provides abundant BSRAM.

The Block SRAM (BSRAM) is embedded as a row in the FPGA array and is different from SSRAM (Shadow SRAM). Each BSRAM occupies three columns of CFU in the FPGA array. Each BSRAM has 18,432 bits (18Kbits). There are five operation modes: single port, dual port, semi-dual port, ROM, and FIFO. The signals and functional descriptions of BSRAM are listed in the following table.

An abundance of BSRAM resources provide a guarantee for the user's high-performance design. BSRAM features include the following:

- Max.18,432 bits per BSRAM
- BSRAM itself can run at 380 MHz at max (typical, Read-before-write is 230 MHz)
- Single port
- Dual port
- Semi-dual port
- Parity bits
- ROM
- Data width from 1 to 36 bits
- Mixed clock mode
- Mixed data width mode
- Enable Byte operation for double byte or above
- Normal read and write mode
- Read-before-write mode
- Write-through Mode

Table 3-4 BSRAM Signals

Port Name	I/O	Description
DIA	I	Port A data input
DIB	I	Port B data input
ADA	I	Port A address
ADB	I	Port B address
CEA	I	Clock enable, Port A
CEB	I	Clock enable, Port B
RESETA	I	Register reset, Port A
RESETB	I	Register reset, Port B
WREA	I	Read/write enable, Port A
WREB	I	Read/write enable, Port B
BLKSELA, BLKSELB	I	Block select
CLKA	I	Read/write cycle clock for Port A input registers
CLKB	I	Read/write cycle clock for Port B input registers
OCEA	I	Clock enable for Port A output registers
OCEB	I	Clock enable for Port B output registers
DOA	O	Port A data output
DOB	O	Port B data output

For further details about BSRAM, please refer to [UG285E, Gowin BSRAM User Guide](#).

3.5.2 Configuration Mode

The BSRAM mode in the GW2AR series of FPGA products supports different data bus widths. See Table 3-5.

Table 3-5 Memory Size Configurations

Single Port Mode	Port	Dual Port Mode	Semi-Dual Port Mode	Read Only
16K x 1		16K x 1	16K x 1	16K x 1
8K x 2		8K x 2	8K x 2	8K x 2
4K x 4		4K x 4	4K x 4	4K x 4
2K x 8		2K x 8	2K x 8	2K x 8
1K x 16		1K x 16	1K x 16	1K x 16
512 x 32		-	512 x 32	512 x 32
2K x 9		2K x 9	2K x 9	2K x 9
1K x 18		1K x 18	1K x 18	1K x 18
512 x 36		-	512 x 36	512 x 36

Single Port Mode

In the single port mode, BSRAM can write to or read from one port at one clock edge. During the write operation, the data can show up at the

output of BSRAM. Normal-Write Mode and Write-through Mode can be supported. When the output register is bypassed, the new data will show at the same write clock rising edge.

For further information about Single Port Block Memory ports and the related description, please refer to [SUG283E, Gowin Primitives User Guide](#) > 3 Memory.

Dual Port Mode

BSRAM support dual port mode. The applicable operations are as follows:

- Two independent read
- Two independent write
- An independent read and an independent write at different clock frequencies

For further information about Dual Port Block Memory ports and the related description, please refer to [SUG283E, Gowin Primitives User Guide](#) > 3 Memory.

Semi-Dual Port Mode

Semi-Dual Port supports read and write at the same time on different ports, but it is not possible to write and read to the same port at the same time. The system only supports write on Port A, read on Port B.

For further information about Semi-Dual Port Block Memory ports and the related description, please refer to [SUG283E, Gowin Primitives User Guide](#) > 3 Memory.

Read Only

BSRAM can be configured as ROM. The ROM can be initialized during the device configuration stage, and the ROM data needs to be provided in the initialization file. Initialization completes during the device power-on process.

Each BSRAM can be configured as one 16 Kbits ROM. For further information about Read Only Port Block Memory ports and the related description, please refer to [SUG283E, Gowin Primitives User Guide](#) > 3 Memory.

3.5.3 Mixed Data Bus Width Configuration

The BSRAM in the GW2AR series of FPGA products supports mixed data bus width operation. In the dual port and semi-dual port modes, the data bus width for read and write can be different. For the configuration options that are available, please see Table 3-6 and Table 3-7 below.

Table 3-6 Dual Port Mixed Read/Write Data Width Configuration

Read Port	Write Port						
	16K x 1	8K x 2	4K x 4	2K x 8	1K x 16	2K x 9	1K x 18
16K x 1	*	*	*	*	*		
8K x 2	*	*	*	*	*		
4K x 4	*	*	*	*	*		
2K x 8	*	*	*	*	*		
1K x 16	*	*	*	*	*		
2K x 9						*	*
1K x 18						*	*

Note!

“*” denotes the modes supported.

Table 3-7 Semi Dual Port Mixed Read/Write Data Width Configuration

Read Port	Write Port								
	16K x 1	8K x 2	4K x 4	2K x 8	1K x 16	512x32	2K x 9	1K x 18	512 x 36
16K x 1	*	*	*	*	*	*			
8K x 2	*	*	*	*	*	*			
4K x 4	*	*	*	*	*	*			
2K x 8	*	*	*	*	*	*			
1K x 16	*	*	*	*	*	*			
512 x 32	*	*	*	*	*	*			
2K x 9							*	*	*
1K x 18							*	*	*

Note!

“*” denotes the modes supported.

3.5.4 Byte-enable

The BSRAM in the GW2AR series of FPGA products support byte-enable. For data longer than a byte, the additional bits can be blocked, and only the selected portion can be written into. The blocked bits will be retained for future operation. Read/write enable ports (WREA, WREB), and byte-enable parameter options can be used to control the BSRAM write operation.

3.5.5 Parity Bit

There are parity bits in BSRAMs. The 9th bit in each byte can be used as a parity bit to check the correctness of data transmission. It can also be

used for data storage.

3.5.6 Synchronous operation

- All the input registers of BSRAM support synchronous write.
- The output register can be used as a pipeline register to improve design performance.
- The output registers are bypass-able.

3.5.7 Power up Conditions

BSRAM initialization is supported when powering up. During the power-up process, BSRAM is in standby mode, and all the data outputs are “0”. This also applies in ROM mode.

3.5.8 BSRAM Operation Modes

BSRAM supports five different operations, including two read operations (Bypass Mode and Pipeline Read Mode) and three write operations (Normal Write Mode, Write-through Mode, and Read-before-write Mode).

Read Mode

Read data from the BSRAM via output registers or without using the registers.

Pipeline Mode

While writing in the BSRAM, the output register and pipeline register are also being written. The data bus can be up to 36 bits in this mode.

Bypass Mode

The output register is not used. The data is kept in the output of the memory array.

Figure 3-29 Pipeline Mode in Single Port, Dual Port and Semi-Dual Port

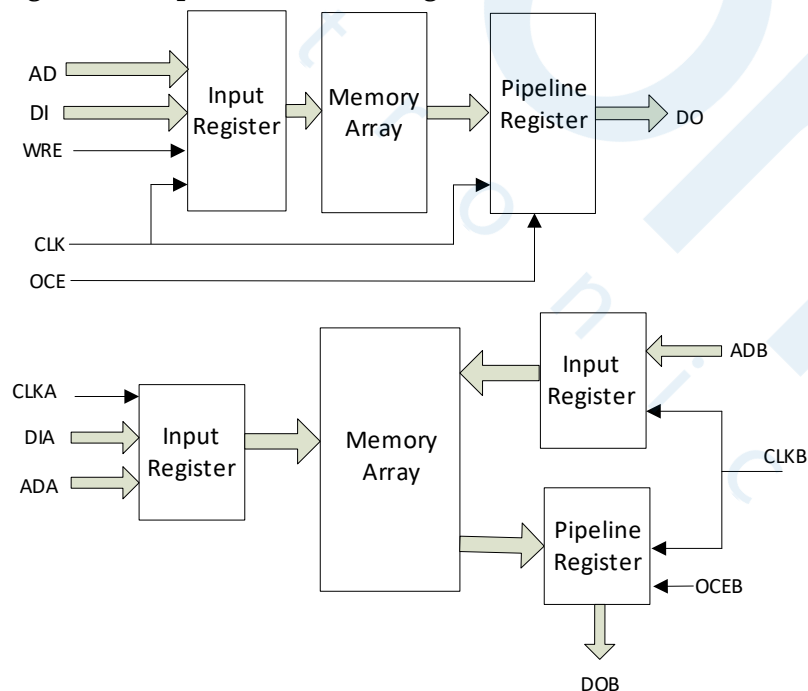

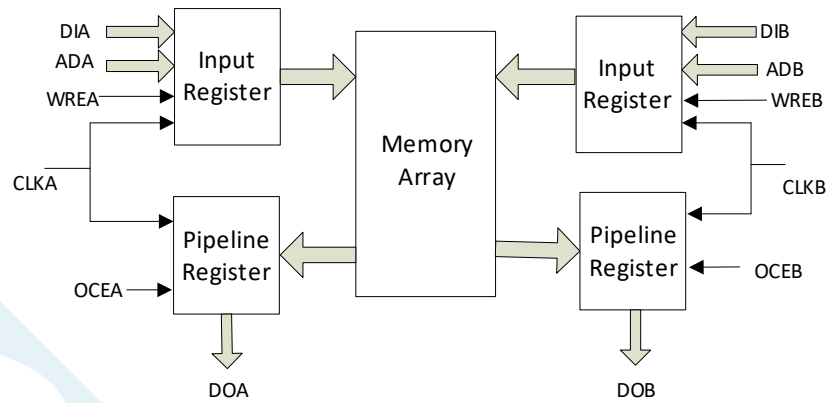

Write Mode

NORMAL WRITE MODE

In this mode, when the user writes data to one port, and the output data of this port does not change. The data written in will not appear at the read port.

WRITE-THROUGH MODE

In this mode, when the user writes data to one port, and the data written in will also appear at the output of this port.

READ-BEFORE-WRITE MODE

In this mode, when the user writes data to one port, and the data written in will be stored in the memory according to the address. The original data in this address will appear at the output of this port.

3.5.9 Clock Operations

Table 3-8 lists the clock operations in different BSRAM modes:

Table 3-8 Clock Operations in Different BSRAM Modes

Clock Operations	Dual Port Mode	Semi-Dual Port Mode	Single Port Mode
Independent Clock Mode	Yes	No	No
Read/Write Clock Mode	Yes	Yes	No
Single Port Clock Mode	No	No	Yes

Independent Clock Mode

Figure 3-30 shows the independent clocks in the dual port mode with each port with one clock. CLKA controls all the registers at Port A; CLKB controls all the registers at Port B.

Figure 3-30 Independent Clock Mode

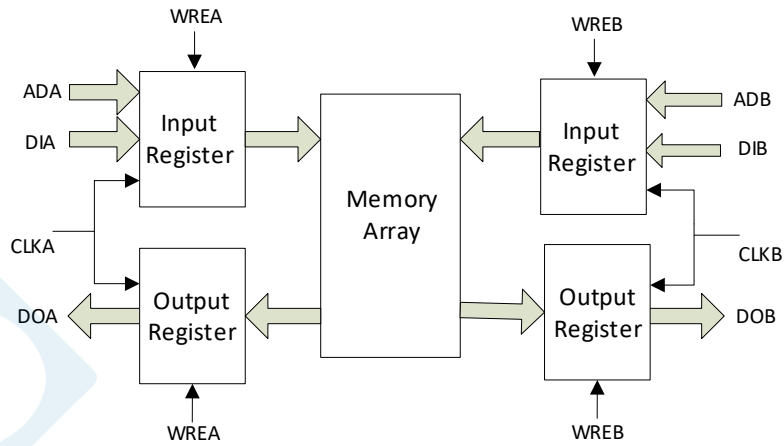

Read/Write Clock Operation

Figure 3-31 shows the read/write clock operations in the semi-dual port mode with one clock at each port. The write clock (CLKA) controls Port A data inputs, write address and read/write enable signals. The read clock (CLKB) controls Port B data output, read address, and read enable signals.

Figure 3-31 Read/Write Clock Mode

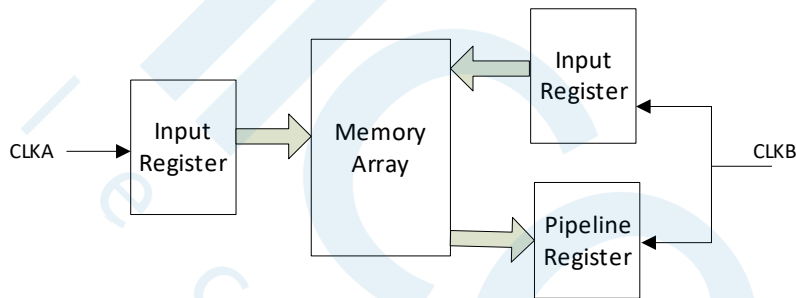

Single Port Clock Mode

Figure 3-32 shows the clock operation in single port mode.

Figure 3-32 Single Port Clock Mode

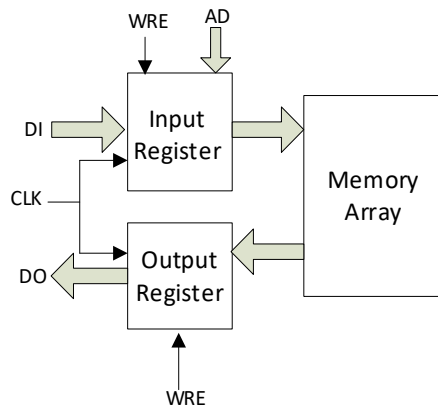

3.6 DSP

3.6.1 Introduction

The GW2AR series of FPGA products has abundant DSP modules. Gowin DSP solutions can meet user demands for high performance digital signal processing design, such as FIR, FFT, etc. DSP blocks have the advantages of stable timing performance, high-usage, and low-power.

DSP offers the following functions:

- Multiplier with three widths: 9-bit, 18-bit, 36-bit
- 54-bit ALU
- Multipliers cascading to support wider data
- Barrel Shifter
- Adaptive filtering through signal feedback
- Computing with options to round to a positive number or a prime number
- Supports pipeline mode and bypass mode.

Macro

DSP blocks are embedded as a row in the FPGA array. Each DSP block contains two Macros, and each Macro contains two pre-adders, two 18 x 18 bit multipliers, and one three-input ALU.

Figure 3-33 shows the structure of one Macro:

Figure 3-33 DSP Macro

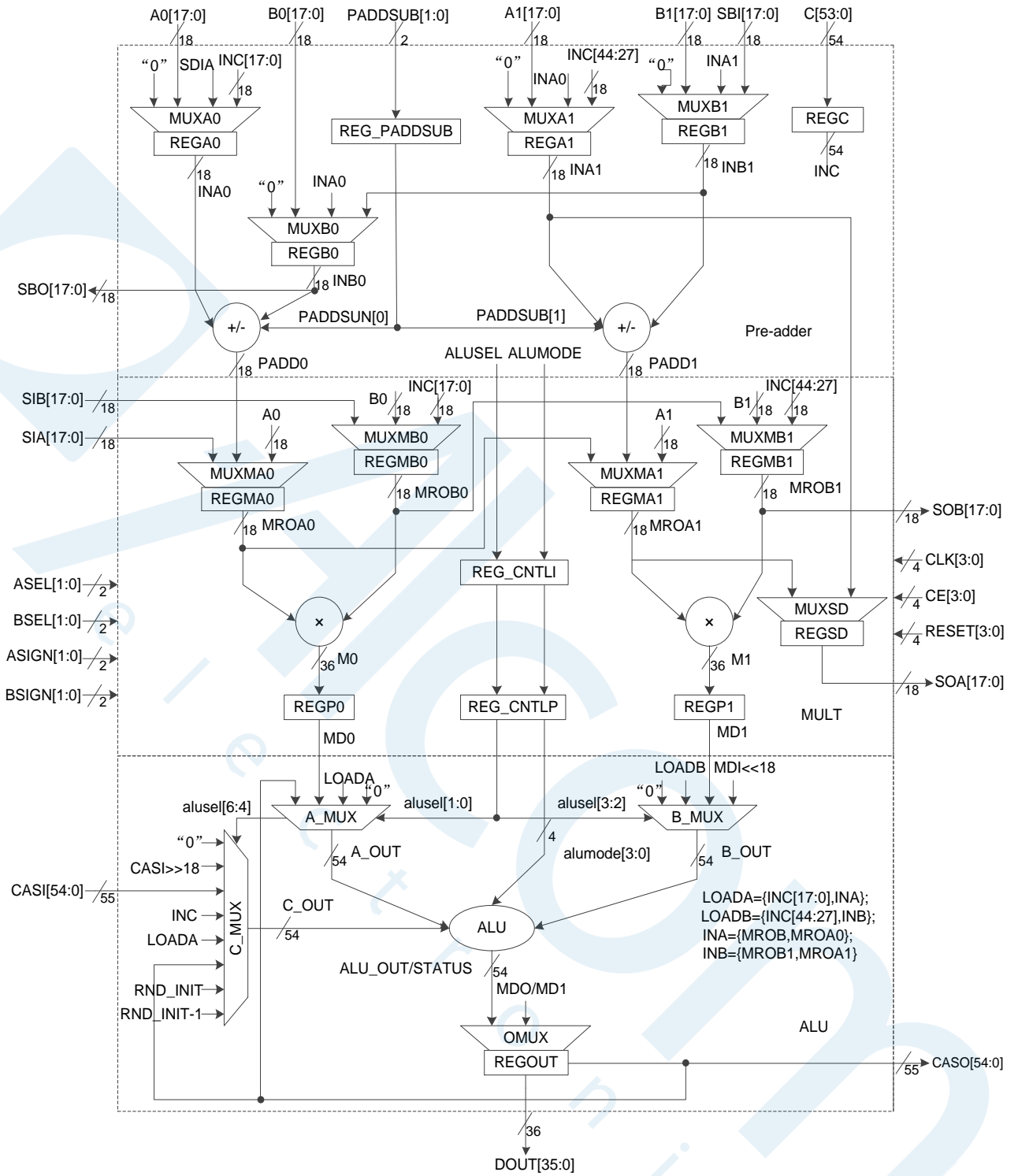

Table 3-9 shows DSP ports description. Table 310 shows internal registers.

Table 3-9 DSP Ports Description

Port Name	I/O	Description
A0[17:0]	I	18-bit data input A0
B0[17:0]	I	18-bit data input B0
A1[17:0]	I	18-bit data input A1

Port Name	I/O	Description
B1[17:0]	I	18-bit data input B1
C[53:0]	I	54-bit data input C
SIA[17:0]	I	Shift data input A, used for CASCADE connection. The input signal SIA is directly connected to the output signal SOA of previously adjacent DSP and the delay from SIA to SOA inside a DSP is one clock cycle.
SIB[17:0]	I	Shift data input B, used for CASCADE connection. The input signal SIB is directly connected to the output signal SOB of previously adjacent DSP and the delay from SIB to SOB inside a DSP is one clock cycle.
SBI[17:0]	I	Pre - adder logic shift input, backward direction.
CASI[54:0]	I	ALU input from previous DSP block, used for cascade connection.
PADDSI0[1:0]	I	Source select for Multiplier or pre-adder input A
BSEL[1:0]	I	Source select for Multiplier input B
ASIGN[1:0]	I	Sign bit for input A
BSIGN[1:0]	I	Sign bit for input B
PADDSUB[1:0]	I	Operation control signals of pre-adder, used for pre-adder logic add/subtract selection
CLK[3:0]	I	Clock input
CE[3:0]	I	Clock Enable
RESET[3:0]	I	Reset input, synchronous or asynchronous
SOA[17:0]	O	Shift data output A
SOB[17:0]	O	Shift data output B
SBO[17:0]	O	Pre - adder logic shift output, backward direction.
DOUT[35:0]	O	DSP output data
CASO[54:0]	O	ALU output to next DSP block for cascade connection, the highest bit is sign-extended.

Table 310 Internal Registers Description

Register	Description and Associated Attributes
A0 register	Registers for A0 input
A1 register	Registers for A1 input
B0 register	Registers for B0 input
B1 register	Registers for B1 input
C register	C register
P1_A0 register	Registers for A0 input of left multiplier
P1_A1 register	Registers for A1 input of right multiplier
P1_B0 register	Registers for B0 input of left multiplier
P1_B1 register	Registers for B1 input of right multiplier
P2_0 register	Registers for pipeline of left multiplier
P2_1 register	Registers for pipeline of right multiplier
OUT register	Registers for DOUT output
OPMODE register	Registers for operation mode control
SOA register	Registers for shift output at port SOA

PADD

Each DSP macro features two units of pre-adders to implement pre-add, pre-subtraction, and shifting.

PADD locates at the first stage with two inputs.,

- Parallel 18-bit input B or SBI;
- Parallel 18-bit input A or SIA.

Each input end supports Pipeline Mode and Bypass Mode. GOWINSEMI PADD can be used as function block independently, which supports 9-bit and 18-bit width.

MULT

Multipliers locate after the pre-adder. Multipliers can be configured as 9 x 9, 18 x 18, 36 x 18 or 36 x 36. Pipeline Mode and Bypass Mode are supported both in input and output ports. The configuration modes that a macro supports include:

- One 18 x 36 multiplier
- Two 18 x 18 multipliers
- Four 9 x 9 multipliers

Two adjacent DSP macros can form a 36 x 36 multiplier.

ALU

Each Macro has one 54 bits ALU54, which can further enhance MULT's functions. Registered Mode and Bypass Mode are supported both in input and output ports. The functions are as following:

- Multiplier output data / 0, addition/subtraction operations for data A and data B;
- Multiplier output data / 0, addition/subtraction operations for data B and bit C;
- Addition/subtraction operations for data A, data B, and bit C;

3.6.2 DSP Operations

- Multiplier
- Accumulator
- MULTADDALU

For further information about DSP, please refer to [UG287E, Gowin DSP User Guide](#).

3.7 Clock

The clock resources and wiring are critical for high-performance applications in FPGA. The GW2AR series of FPGA products provides the global clock network (GCLK) which connects to all the registers directly. Besides the global clock network, the GW2AR series of FPGA products provide PLL, high speed clock HCLK, DDR memory interface, DQS, etc.

Figure3-34 GW2AR Clock Resources

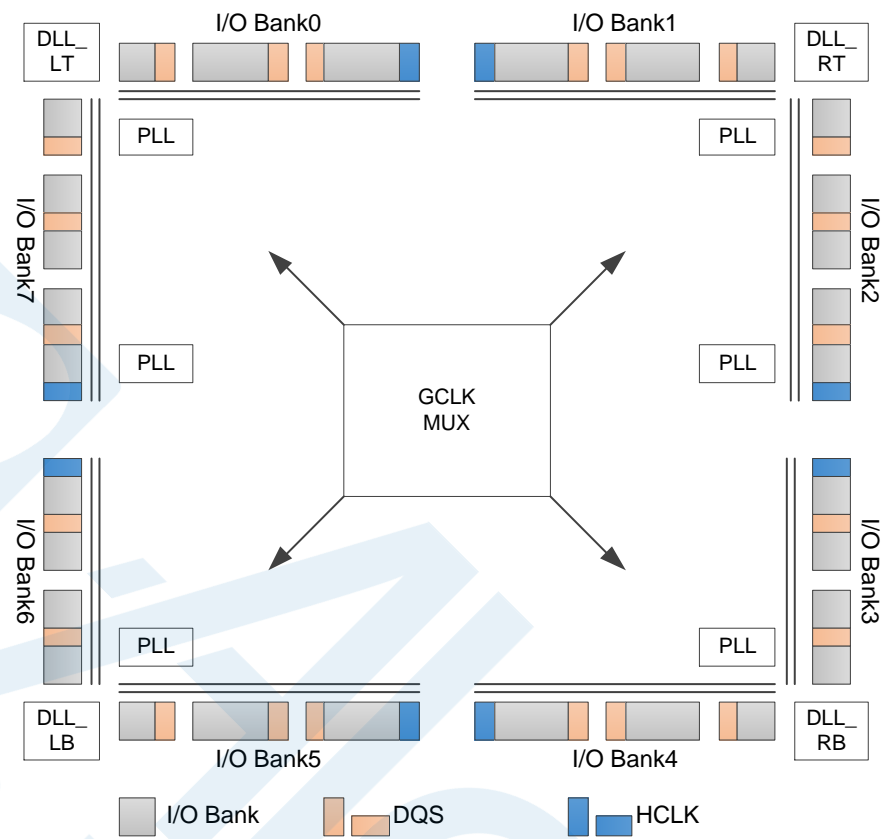

3.7.1 Global Clock

The GCLK is distributed in the GW2AR devices as four quadrants. Each quadrant provides eight GCLKs. The optional clock resources of GCLK can be pins or CRU. Users can employ dedicated pins as clock resources to achieve better timing.

Figure 3-35 GCLK Quadrant Distribution

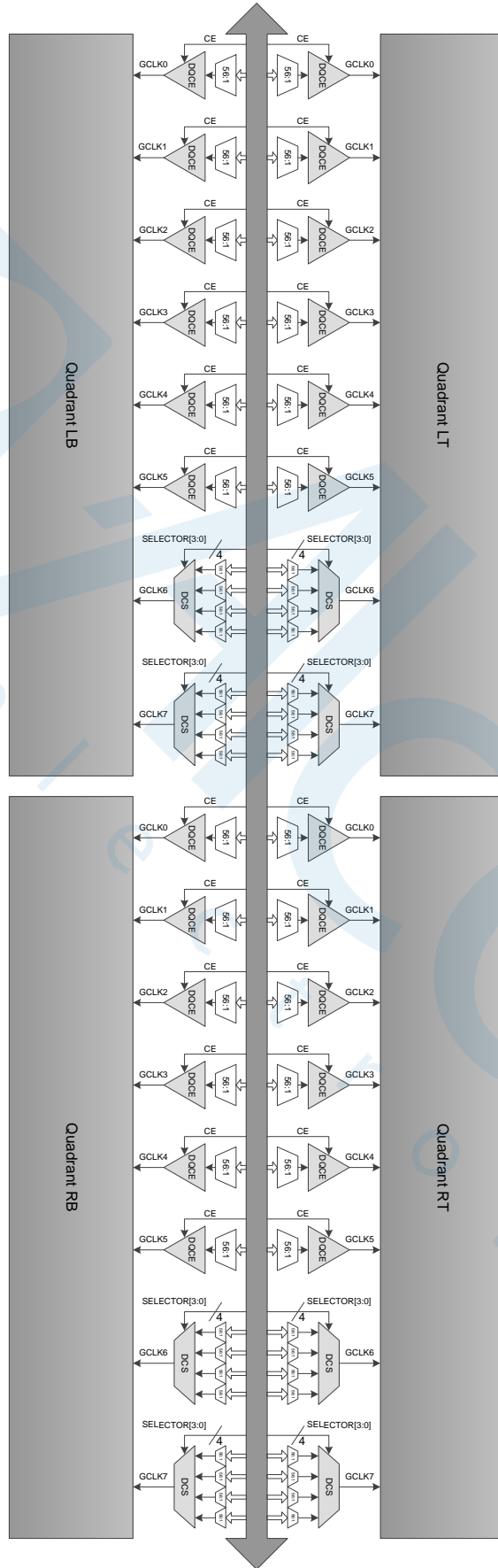

GCLK0~GCLK5 can be turned on or off by Dynamic Quadrant Clock Enable (DQCE). When GCLK0~GCLK5 in the quadrant is off, all the logic driven by it will not toggle; therefore, lower power can be achieved.

Figure 3-36 DQCE Concept

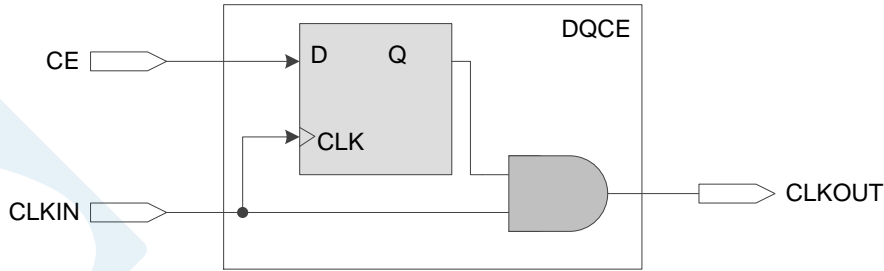

GCLK6~GCLK7 of each quadrant is controlled by the DCS, as shown in Figure 3-37. Select dynamically between CLK0~CLK3 by CRU, and output a glitch-free clock.

Figure 3-37 DCS Concept

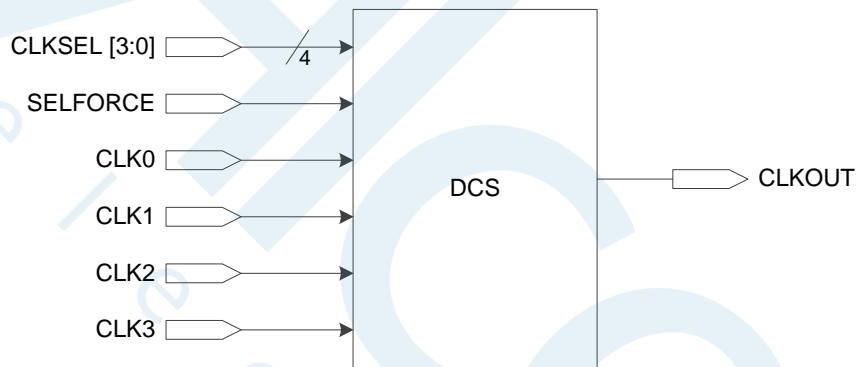

DCS can be configured in the following modes:

DCS Rising Edge

Stay as 1 after current selected clock rising edge, and the new select clock will be effective after its first rising edge, as shown in Figure 3-38.

Figure 3-38 DCS Rising Edge

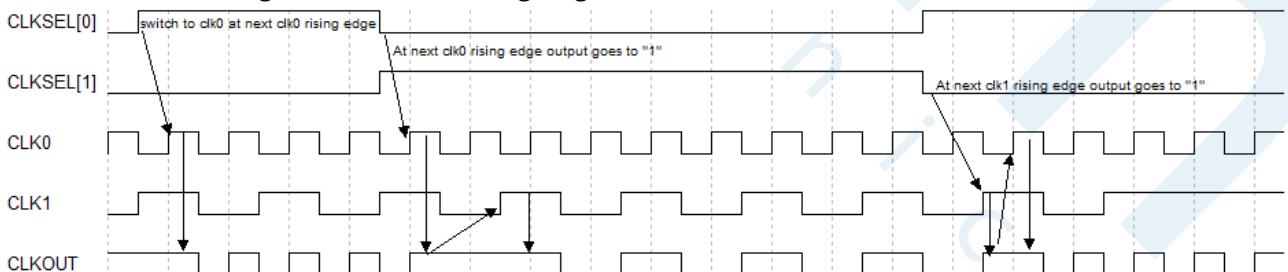

DCS Falling Edge

Stay as 0 after current selected clock falling edge, and the new select clock will be effective after its first falling edge, as shown in Figure 3-39.

Figure 3-39 DCS Falling Edge

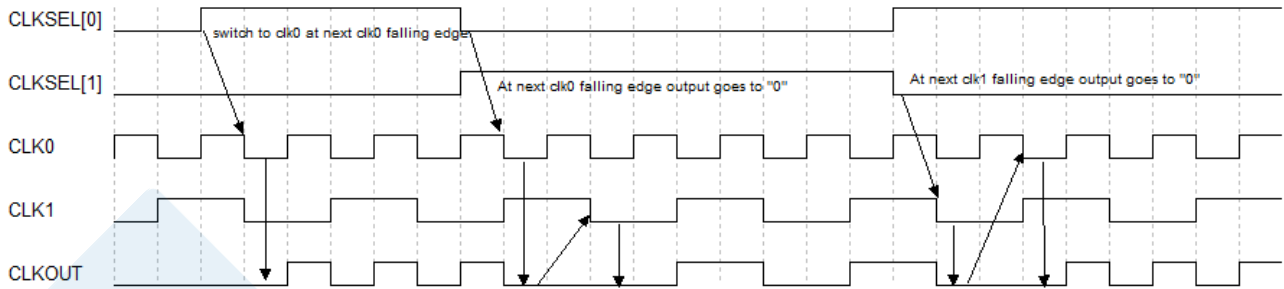

Clock Buffer Mode

In this mode, DCS acts as a clock buffer.

3.7.2 PLL

PLL (Phase-locked Loop) is one kind of a feedback control circuit. The frequency and phase of the internal oscillator signal is controlled by the external input reference clock.

PLL blocks in the GW2AR series FPGA products provide the ability to synthesize clock frequencies. Frequency adjustment (multiply and division), phase adjustment, and duty cycle can be adjusted by configuring the parameters.

See Figure 3-40 for the PLL structure.

Figure 3-40 PLL Structure

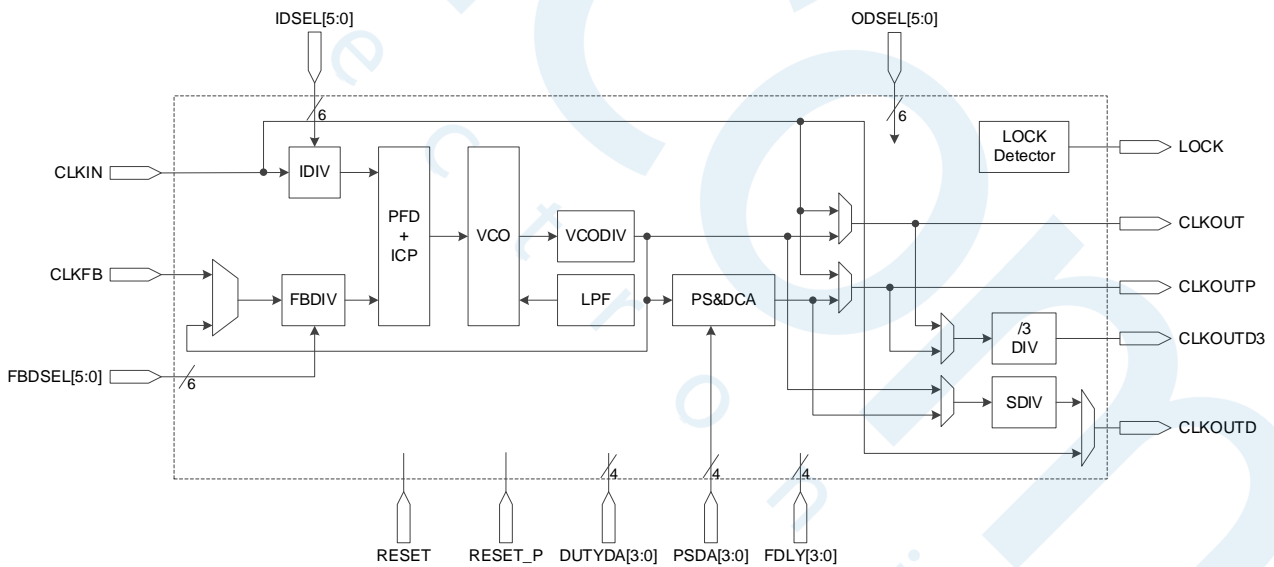

See Table 3-11 for the definition of the PLL ports.

Table 3-11 Definition of the PLL Ports

Port Name	Signal	Description
CLKIN [5:0]	I	Reference clock input
CLKFB	I	Feedback clock input
RESET	I	PLL reset
RESET_P	I	PLL Power Down
INSEL[2:0]	I	Dynamic clock control selector: 0~5
IDSEL [5:0]	I	Dynamic IDIV control: 1~64
FBDSEL [5:0]	I	Dynamic FBDIV control:1~64
PSDA [3:0]	I	Dynamic phase control (rising edge effective)
DUTYDA [3:0]	I	Dynamic duty cycle control (falling edge effective)
FDLY[3:0]	I	CLKOUTP dynamic delay control
CLKOUT	O	Clock output with no phase and duty cycle adjustment
CLKOUTP	O	Clock output with phase and duty cycle adjustment
CLKOUTD	O	Clock divider from CLKOUT and CLKOUTP (controlled by SDIV)
CLKOUTD3	O	clock divider from CLKOUT and CLKOUTP (controlled by DIV3 with the constant division value 3)
LOCK	O	PLL lock status: 1 locked, 0 unlocked

The PLL reference clock source can come from an external PLL pin or from internal routing GCLK, HCLK, or general data signal. PLL feedback signal can come from the external PLL feedback input or from internal routing GCLK, HCLK, or general data signal.

For the PLL features, please refer to Table 4-18 PLL Switching Characteristic.

PLL can adjust the frequency of the input clock CLKIN (multiply and division). The formulas for doing so are as follows:

1. $f_{\text{CLKOUT}} = (f_{\text{CLKIN}} * \text{FBDIV}) / \text{IDIV}$
2. $f_{\text{VCO}} = f_{\text{CLKOUT}} * \text{ODIV}$
3. $f_{\text{CLKOUTD}} = f_{\text{CLKOUT}} / \text{SDIV}$
4. $f_{\text{PFD}} = f_{\text{CLKIN}} / \text{IDIV} = f_{\text{CLKOUT}} / \text{FBDIV}$

Note!

- f_{CLKIN} : The frequency of the input clock CLKIN
- f_{CLKOUT} : The clock frequency of CLKOUT and CLKOUTP
- f_{CLKOUTD} : The clock frequency of CLKOUTD, and CLKOUTD is the clock CLKOUT after division
- f_{PFD} : PFD Phase Comparison Frequency, and the minimum value of f_{PFD} should be no less than 3MHz.

Adjust IDIV, FBDIV, ODIV, and SDIV to achieve the required clock frequency.

3.7.3 HCLK

HCLK is the high-speed clock in the GW2AR series of FPGA products. It can support high-performance data transfer and is mainly suitable for source synchronous data transfer protocols. See Figure Figure 3-41.

Figure 3-41 GW2AR HCLK Distribution

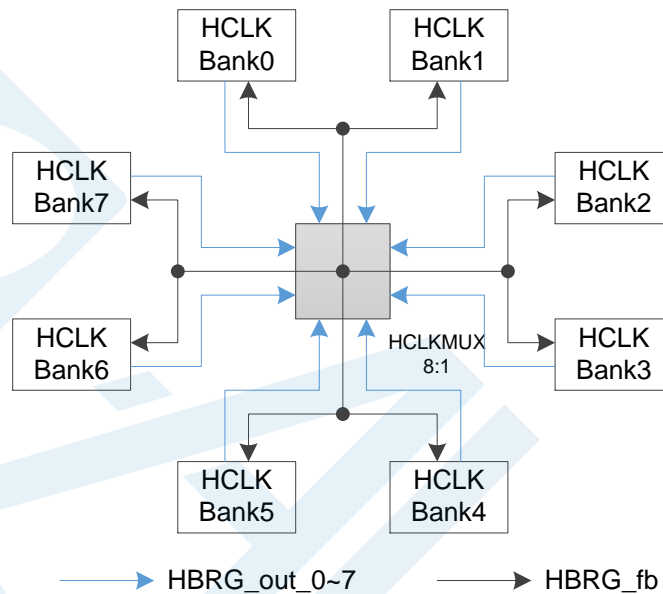

As shown in Figure 3-41, there is an 8: 1 HCLKMUX module in the middle of the high-speed clock HCLK. HCLKMUX can send HCLK clock signal from any Bank to any other bank, which makes the use of HCLK more flexible.

HCLK can provide user with the function modules as follows:

- DHCEN: Dynamic high-speed clock enable module, functions similar to DQCE. Dynamically turn on / off high-speed clock signal.
- CLKDIV / CLKDIV2: High-speed clock divider module, each bank has a CLKDIV. Generates a clock divided by the input clock phase, which is used in the IO logic mode.
- DCS: Dynamic High Speed Clock Selector.
- DLLDLY: The dynamic delay adjustment module, the clock signal for the dedicated clock pin input.

3.7.4 DDR Memory Interface Clock Management DQS

DQS module of the GW2AR series of FPGA products provides the following features to support the clock requirements of the DDR memory interface:

- Receive DQS input, sort out waveform and shift 1/4 phase
- Provide a read / write pointer for input cache
- Provide valid data for internal logic
- Provide DDR output clock signal

- Support DDR3 write voltage control

The DQS module has three operating modes to meet the needs of different I/O interfaces, as shown in Figure 3-42.

Figure 3-42 DQS

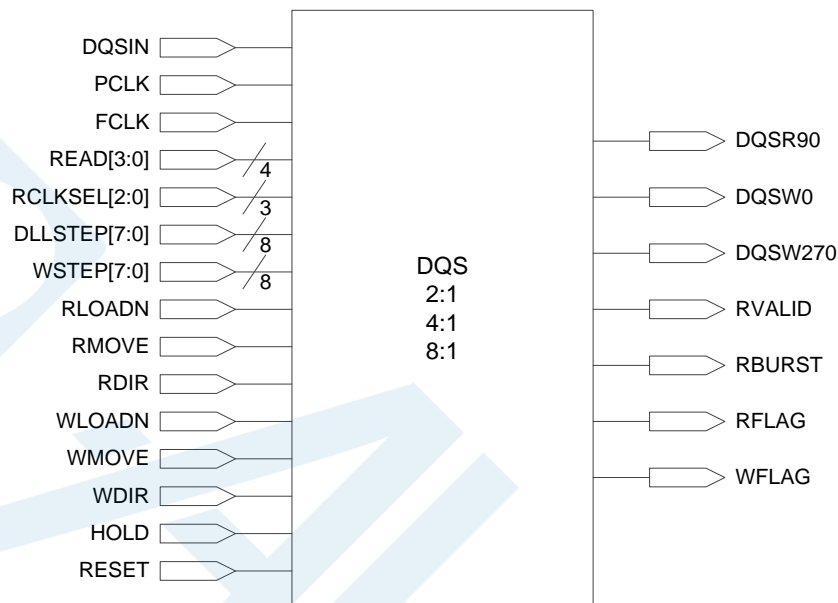

CDRCLKGEN

CDRCLKGEN is used to support high-speed asynchronous input interfaces, such as SGMII. Each location has only one DQS and CDRCLKGEN.

CDRCLKDIV

The function of the clock divider module is similar to that of HCLKDIV.

3.8 Long Wire (LW)

As a supplement to the CRU, the GW2AR series of FPGA products provides another routing resource, Long Wire, which can be used as clock, clock enable, set/reset, or other high fan out signals.

3.9 Global Set/Reset (GSR)

A global set/reset (GSR) network is built in the GW2AR series of FPGA product. There is a direct connection to core logic. It can be used as asynchronous/synchronous set. The registers in CFU and I/O can be individually configured to use GSR.

3.10 Programming Configuration

The GW2AR series of FPGA products support SRAM. Each time the device is powered on, the bit stream needs to be downloaded to configure the device. Users can select to keep backup data in external Flash chip according to requirements. After power-up, the GW2AR device reads configuration data from external Flash and writes into the SRAM.

Besides JTAG, GW2AR series FPGA products also support GOWINSEMI own configuration mode GowinCONFIG: SSPI, MSPI, SERIAL, and CPU. For more detailed information, please refer to [UG290, Gowin FPGA Products Programming and Configuration User Guide](#).

3.11 On Chip Oscillator

There is an internal oscillator in each of the GW2AR series of FPGA products. During the configuration process, it can provide a clock for the MSPI mode. See Table 3-12 for the output frequency.

Table 3-12 Oscillator Output Frequency Options

Mode	Frequency	Mode	Frequency	Mode	Frequency
0	2.5MHz ¹	8	7.8MHz	16	15.6MHz
1	5.4MHz	9	8.3MHz	17	17.9MHz
2	5.7MHz	10	8.9MHz	18	21MHz
3	6.0MHz	11	9.6MHz	19	25MHz
4	6.3MHz	12	10.4MHz	20	31.3MHz
5	6.6MHz	13	11.4MHz	21	41.7MHz
6	6.9MHz	14	12.5MHz	22	62.5MHz
7	7.4MHz	15	13.9MHz	23	125MHz ²

Note!

- [1] Default frequency is 2.5MHz.
- [2] 125 MHz is not suitable for MSPI.

The on-chip oscillator also provides a clock resource for user designs. Up to 64 clock frequencies can be obtained by setting the parameters. The following formula is employed to get the output clock frequency:

$$f_{\text{out}} = 250\text{MHz} / \text{Param}$$

“Param” is the configuration parameter with a range of 2~128. It supports even number only.

4 AC/DC Characteristics

Note!

Users should ensure GOWINSEMI products are always used within recommended operating conditions and range. Data beyond the working conditions and range are for reference only. GOWINSEMI does not guarantee that all devices will operate as expected beyond the standard operating conditions and range.

4.1 Operating Conditions

4.1.1 Absolute Max. Ratings

Table 4-1 Absolute Max. Ratings

Name	Description	Min.	Max.
V _{CC}	Core voltage	-0.5V	1.1V
V _{CCPLL}	PLL Power	-0.5V	1.1V
V _{CCO}	I/O Bank Power	-0.5V	3.75V
V _{CCX}	Auxiliary Power	-0.5V	3.75V
Storage Temperature	Storage Temperature	-65 °C	+150 °C
Junction Temperature	Junction Temperature	-40°C	+125°C

4.1.2 Recommended Operating Conditions

Table 4-2 Recommended Operating Conditions

Name	Description	Min.	Max.
V _{CC}	Core voltage	0.95V	1.05V
V _{CCPLLx}	Left PLL power supply	0.95V	1.05V
V _{CCPLLrx}	Right PLL power supply	0.95V	1.05V
V _{CCOx}	I/O Bank Power supply	1.14V	3.465V
V _{CCX}	Auxiliary voltage	2.7V	3.465V
T _{JCOM}	Junction temperature Commercial operation	0°C	+85°C
T _{JIND}	Junction temperature Industrial operation	-40°C	+100°C
T _{RAMP}	Power supply ramp rates for all power supplies	0.01mV/μs	10mV/μs

Note!

For further detailed power supply information for different packages, please refer to [UG115](#).

[GW2AR-18 Pinout.](#)

4.1.3 Power Supply Ramp Rates

Table 4-3 Power Supply Ramp Rates

Name	Description	Min.	Typ.	Max.
T _{RAMP}	Power supply ramp rates for all power supplies	0.01mV/μs	-	10mV/μs

4.1.4 Hot Socket Specifications

Table 4-4 Hot Socket Specifications

Name	Description	Condition	I/O	Max.
I _{HS}	Input leakage current (Input or I/O leakage current)	V _{IN} =V _{IL} (MAX)	I/O	150uA
I _{HS}	Input leakage current (Input or I/O leakage current)	V _{IN} =V _{IL} (MAX)	TDI,TDO TMS,TCK	120uA

4.1.5 POR Specifications

Table 4-5 POR Specifications

Name	Description	Name	Min.	Max.
POR Voltage	Power on reset voltage of Vcc	VCC	0.7V	0.88V
		VCCX	2.1V	2.6V
		VCCIO	0.85V	0.98V

4.2 ESD

Table 4-6 GW2AR ESD - HBM

Device	GW2AR-18
LQ144	HBM>1,000V
EQ144/EQ144P/EQ144PF	HBM>1,000V
QN88/QN88P/QN88PF	HBM>1,000V
LQ176	HBM>1,000V
EQ176	HBM>1,000V
PG256S	HBM>1,000V

Table 4-7 GW2AR ESD - CDM

Device	GW2AR-18
LQ144	CDM>500V
EQ144/EQ144P/EQ144PF	CDM>500V
QN88/QN88P/QN88PF	CDM>500V
LQ176	CDM>500V
EQ176	CDM>500V
PG256S	CDM>500V

4.3 DC Electrical Characteristics

4.3.1 DC Electrical Characteristics over Recommended Operating Conditions

Table 4-8 DC Electrical Characteristics over Recommended Operating Conditions

Name	Description	Condition	Min.	Typ.	Max.
I_{IL}, I_{IH}	Input or I/O leakage	$V_{CCO} < V_{IN} < V_{IH}(MAX)$	-	-	210 μ A
		$0V < V_{IN} < V_{CCO}$	-	-	10 μ A
I_{PU}	I/O Active Pull-up Current	$0 < V_{IN} < 0.7V_{CCO}$	-	-100 μ A	-
I_{PD}	I/O Active Pull-down Current	$V_{IL}(MAX) < V_{IN} < V_{CCO}$	-	100 μ A	-
I_{BHLS}	Bus Hold Low Sustaining Current	$V_{IN} = V_{IL}(MAX)$	30 μ A	-	-
I_{BHHS}	Bus Hold High Sustaining Current	$V_{IN} = 0.7V_{CCO}$	-30 μ A	-	-
I_{BHLO}	Bus Hold Low Overdrive Current	$0 \leq V_{IN} \leq V_{CCO}$	-	-	150 μ A
I_{BHHO}	BusHoldHigh Overdrive Current	$0 \leq V_{IN} \leq V_{CCO}$	-	-	-150 μ A
V_{BHT}	Bus hold trip points	-	$V_{IL}(MAX)$	-	$V_{IH}(MIN)$
C1	I/O Capacitance	-	-	5pF	8pF
V_{HYST}	Hysteresis for Schmitt Trigger inputs	$V_{CCO} = 3.3V, \text{Hysteresis} = L2H$	-	240mV	-
		$V_{CCO} = 2.5V, \text{Hysteresis} = L2H$	-	140mV	-
		$V_{CCO} = 1.8V, \text{Hysteresis} = L2H$	-	65mV	-
		$V_{CCO} = 1.5V, \text{Hysteresis} = L2H$	-	30mV	-
		$V_{CCO} = 3.3V, \text{Hysteresis} = H2L$	-	200mV	-
		$V_{CCO} = 2.5V, \text{Hysteresis} = H2L$	-	130mV	-
		$V_{CCO} = 1.8V, \text{Hysteresis} = H2L$	-	60mV	-
		$V_{CCO} = 1.5V, \text{Hysteresis} = H2L$	-	40mV	-
		$V_{CCO} = 3.3V, \text{Hysteresis} = High$	-	440mV	-
		$V_{CCO} = 2.5V, \text{Hysteresis} = High$	-	270mV	-
		$V_{CCO} = 1.8V, \text{Hysteresis} = High$	-	125mV	-
		$V_{CCO} = 1.5V, \text{Hysteresis} = High$	-	70mV	-

4.3.2 Static Supply Current

Table 4-9 Static Supply Current

Name	Description	Device	Typ.
$I_{CC}^{(1)}$	Core Current	GW2A-55 ⁽²⁾	150mA
		GW2A-18	70mA
$I_{CCX}^{(2)}$	V_{CCX} current	GW2A-55	35mA
		GW2A-18	15mA
I_{CCO}	I/O Bank current ($V_{CCO}=3.3V$)	GW2A-55	<2mA
		GW2A-18	<2mA

Note!

- [1] Tested with $V_{CC} = 1V$, room temperature, speed grade -8.
- [2] Tested with $V_{CCX}=3.3V$.

4.3.3 Recommended I/O Operating Conditions

Table 4-10 Recommended I/O Operating Conditions

Name	Output V_{CCO} (V)			Input V_{REF} (V)		
	Min.	Typ.	Max.	Min.	Typ.	Max.
LVTTTL33	3.135	3.3	3.465	-	-	-
LVC MOS33	3.135	3.3	3.465	-	-	-
LVC MOS25	2.375	2.5	2.625	-	-	-
LVC MOS18	1.71	1.8	1.89	-	-	-
LVC MOS15	1.425	1.5	1.575	-	-	-
LVC MOS12	1.14	1.2	1.26	-	-	-
SSTL15	1.425	1.5	1.575	0.68	0.75	0.9
SSTL18_I	1.71	1.8	1.89	0.833	0.9	0.969
SSTL18_II	1.71	1.8	1.89	0.833	0.9	0.969
SSTL25_I	2.375	2.5	2.645	1.15	1.25	1.35
SSTL25_II	2.375	2.5	2.645	1.15	1.25	1.35
SSTL33_I	3.135	3.3	3.465	1.3	1.5	1.7
SSTL33_II	3.135	3.3	3.465	1.3	1.5	1
HSTL18_I	1.71	1.8	1.89	0.816	0.9	1.08
HSTL18_II	1.71	1.8	1.89	0.816	0.9	1.08
HSTL15	1.425	1.5	1.575	0.68	0.75	0.9
PCI33	3.135	3.3	3.465	-	-	-
LVPECL33E	3.135	3.3	3.465	-	-	-
MLVDS25E	2.375	2.5	2.625	-	-	-
BLVDS25E	2.375	2.5	2.625	-	-	-
RSDS25E	2.375	2.5	2.625	-	-	-
LVDS25E	2.375	2.5	2.625	-	-	-
SSTL15D	1.425	1.5	1.575	-	-	-
SSTL18D_I	1.71	1.8	1.89	-	-	-
SSTL18D_II	1.71	1.8	1.89	-	-	-
SSTL25D_I	2.375	2.5	2.625	-	-	-
SSTL25D_II	2.375	2.5	2.625	-	-	-
SSTL33D_I	3.135	3.3	3.465	-	-	-
SSTL33D_II	3.135	3.3	3.465	-	-	-
HSTL15D	1.425	1.575	1.89	-	-	-
HSTL18D_I	1.71	1.8	1.89	-	-	-
HSTL18D_II	1.71	1.8	1.89	-	-	-

4.3.4 IOB Single - Ended DC Electrical Characteristics

Table 4-11 IOB Single - Ended DC Electrical Characteristics

Name	V _{IL}		V _{IH}		V _{OL} (Max)	V _{OH} (Min)	I _{OL} (mA)	I _{OH} (mA)
	Min	Max	Min	Max				
LVCMOS33 LVTTTL33	-0.3V	0.8V	2.0V	3.6V	0.4V	V _{CCO} -0.4V	4	-4
							8	-8
							12	-12
							16	-16
					24	-24		
					0.2V	V _{CCO} -0.2V	0.1	-0.1
LVCMOS25	-0.3V	0.7V	1.7V	3.6V	0.4V	V _{CCO} -0.4V	4	-4
							8	-8
							12	-12
					16	-16		
					0.2V	V _{CCO} -0.2V	0.1	-0.1
LVCMOS18	-0.3V	0.35 x V _{CCO}	0.65 x V _{CCO}	3.6V	0.4V	V _{CCO} -0.4V	4	-4
							8	-8
					12	-12		
					0.2V	V _{CCO} -0.2V	0.1	-0.1
LVCMOS15	-0.3V	0.35 x V _{CCO}	0.65 x V _{CCO}	3.6V	0.4V	V _{CCO} -0.4V	4	-4
							8	-8
					0.2V	V _{CCO} -0.2V	0.1	-0.1
LVCMOS12	-0.3V	0.35 x V _{CCO}	0.65 x V _{CCO}	3.6V	0.4V	V _{CCO} -0.4V	2	-2
							4	-4
					0.2V	V _{CCO} -0.2V	0.1	-0.1
PCI33	-0.3V	0.3 x V _{CCO}	0.5 x V _{CCO}	3.6V	0.1 x V _{CCO}	0.9 x V _{CCO}	1.5	-0.5
SSTL33_I	-0.3V	V _{REF} -0.2V	V _{REF} +0.2V	3.6V	0.7	V _{CCO} -1.1V	8	-8
SSTL25_I	-0.3V	V _{REF} -0.18V	V _{REF} +0.18V	3.6V	0.54V	V _{CCO} -0.62V	8	-8
SSTL25_II	-0.3V	V _{REF} -0.18V	V _{REF} +0.18V	3.6V	NA	NA	NA	NA
SSTL18_II	-0.3V	V _{REF} -0.125V	V _{REF} +0.125V	3.6V	NA	NA	NA	NA
SSTL18_I	-0.3V	V _{REF} -0.125V	V _{REF} +0.125V	3.6V	0.40V	V _{CCO} -0.40V	8	-8
SSTL15	-0.3V	V _{REF} -0.1V	V _{REF} +0.1V	3.6V	0.40V	V _{CCO} -0.40V	8	-8
HSTL18_I	-0.3V	V _{REF} -0.1V	V _{REF} +0.1V	3.6V	0.40V	V _{CCO} -0.40V	8	-8
HSTL18_II	-0.3V	V _{REF} -0.1V	V _{REF} +0.1V	3.6V	NA	NA	NA	NA
HSTL15_I	-0.3V	V _{REF} -0.1V	V _{REF} +0.1V	3.6V	0.40V	V _{CCO} -0.40V	8	-8
HSTL15_II	-0.3V	V _{REF} -0.1V	V _{REF} +0.1V	3.6V	NA	NA	NA	NA

4.3.5 I/O Differential Electrical Characteristics

Table 4-12 I/O Differential Electrical Characteristics
LVDS

Name	Description	Condition	Min.	Typ.	Max.	Unit
V_{INA}, V_{INB}	Input Voltage	-	0	-	2.4	V
V_{CM}	Input Common Mode Voltage	-	0.05	-	2.35	V
V_{THD}	Differential Input Threshold	Minimum Input Swing	± 100	-	-	mV
I_{IN}	Input Current	Power On or Power Off	-	-	± 10	μA
V_{OH}	Output High Voltage for V_{OP} or V_{OM}	$R_T = 100\Omega$	-	-	1.6	V
V_{OL}	Output Low Voltage for V_{OP} or V_{OM}	$R_T = 100\Omega$	0.9	-	-	V
V_{OD}	Output Voltage Differential	$(V_{OP} - V_{OM}), R_T = 100\Omega$	250	350	450	mV
ΔV_{OD}	Change in V_{OD} Between High and Low	-	-	-	50	mV
V_{OS}	Output Voltage Offset	$(V_{OP} + V_{OM})/2, R_T = 100\Omega$	1.125	1.2	1.375	V
ΔV_{OS}	Change in V_{OS} Between High and Low	-	-	-	50	mV
I_S	Short-circuit current	$V_{OD} = 0V$, output short-circuit	-	-	15	mA

4.4 AC Switching Characteristics

4.4.1 CFU Switching Characteristics

Table 4-13 CFU Block Internal Timing Parameters

Name	Description	Speed Grade		Unit
		Min	Max	
t_{LUT4_CFU}	LUT4 delay	-	0.337	ns
t_{LUT5_CFU}	LUT5 delay	-	0.694	ns
t_{LUT6_CFU}	LUT6 delay	-	1.005	ns
t_{LUT7_CFU}	LUT7 delay	-	1.316	ns
t_{LUT8_CFU}	LUT8 delay	-	1.627	ns
t_{SR_CFU}	Set/Reset to Register output	-	0.93	ns
t_{CO_CFU}	Clock to Register output	-	0.38	ns

4.4.2 BSRAM Switching Characteristic

Table 4-14 BSRAM Internal Timing Parameters

Name	Description	Speed Grade		Unit
		Min	Max	
t_{COAD_BSRAM}	Clock to output from read address/data	-	2.55	ns
t_{COOR_BSRAM}	Clock to output from output register	-	0.28	ns

4.4.3 DSP Switching Characteristics

Table 4-15 DSP Internal Timing Parameters

Name	Description	Speed Grade		Unit
		Min	Max	
t_{COIR_DSP}	Clock to output from input register	-	2.40	ns
t_{COPR_DSP}	Clock to output from pipeline register	-	1.20	ns
t_{COOR_DSP}	Clock to output from output register	-	0.42	ns

4.4.4 External Switching Characteristics

Table 4-16 External Switching Characteristics

Name	Description	Device	-8		-7		Unit
			Min	Max	Min	Max	
Pin-LUT-Pin Delay ⁽¹⁾	Pin(IOxA) to Pin(IOxB) delay	GW2A(2AR)-18	-	3.83	-	4.59	ns
$T_{HCLKdly}$	HCLK tree delay	GW2A(2AR)-18	-	0.82	-	0.98	ns
$T_{GCLKdly}$	GCLK tree delay	GW2A(2AR)-18	-	1.77	-	2.12	ns

Note!

- Tested with $V_{CCIO}=3.3V$, $V_{CCX} = 3.3V$.

4.4.5 On chip Oscillator Output Frequency

Table 4-17 On chip Oscillator Output Frequency

Name	Description	Min.	Typ.	Max.
f_{MAX}	Output Frequency(0 to+ 85°C)	106.25MHz	125MHz	143.75MHz
	Output Frequency (-40 to +100°C)	100MHz	125MHz	150MHz
t_{DT}	Output Clock Duty Cycle	43%	50%	57%
t_{OPJIT}	Output Clock Period Jitter	0.01UIPP	0.012UIPP	0.02UIPP

4.4.6 PLL Switching Characteristic

Table 4-18 PLL Switching Characteristic

Device	Speed Grade	Name	Min.	Max.
GW2AR-18	C9/18 C8/17 A6	CLKIN	3MHZ	500MHZ
		PFD	3MHZ	500MHZ
		VCO	500MHZ	1250MHZ
		CLKOUT	3.90625 MHZ	625 MHZ
	C7/16	CLKIN	3MHZ	400MHZ
		PFD	3MHZ	400MHZ
		VCO	400MHZ	1000MHZ
		CLKOUT	3.125MHZ	500MHZ

4.5 Configuration Interface Timing Specification

The GW2AR series of FPGA products GowinCONFIG supports the following configuration modes: MSPI, SSPI, CPU, and SERIAL. For more detailed information, please refer to [UG290, Gowin FPGA Products Programming and Configuration User Guide](#).



5 Ordering Information

5.1 Part Name

Note!

- For further pin number and package type information, please refer to [2.2 Product Resources](#)
- The LittleBee[®] family devices and Arora family devices of the same speed level have different speed.
- Both “C” and “I” are used in GOWIN part name marking for one same device, such as C6/I5, C7/I6, etc. GOWIN devices are screened using industrial standards, so one same device can be used for both industrial (I) and commercial (C) applications. The maximum temperature of the industrial grade is 100°C, and the maximum temperature of the commercial grade is 85°C. Therefore, if the same chip meets the speed level 7 in the commercial grade application, the speed level is 6 in the industrial grade application.

Figure 5-1 Part Naming of Devices with SDRAM Embedded-ES

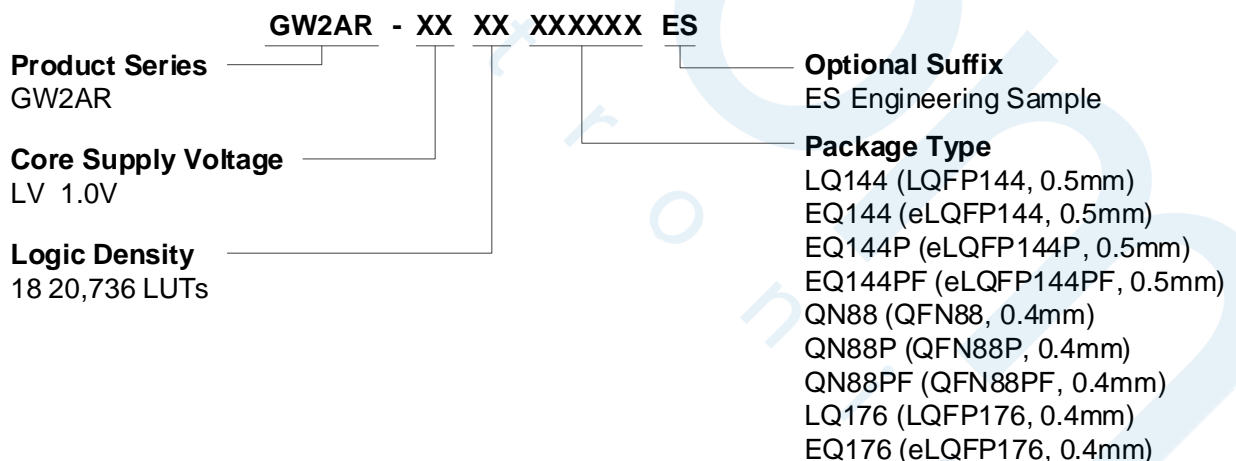
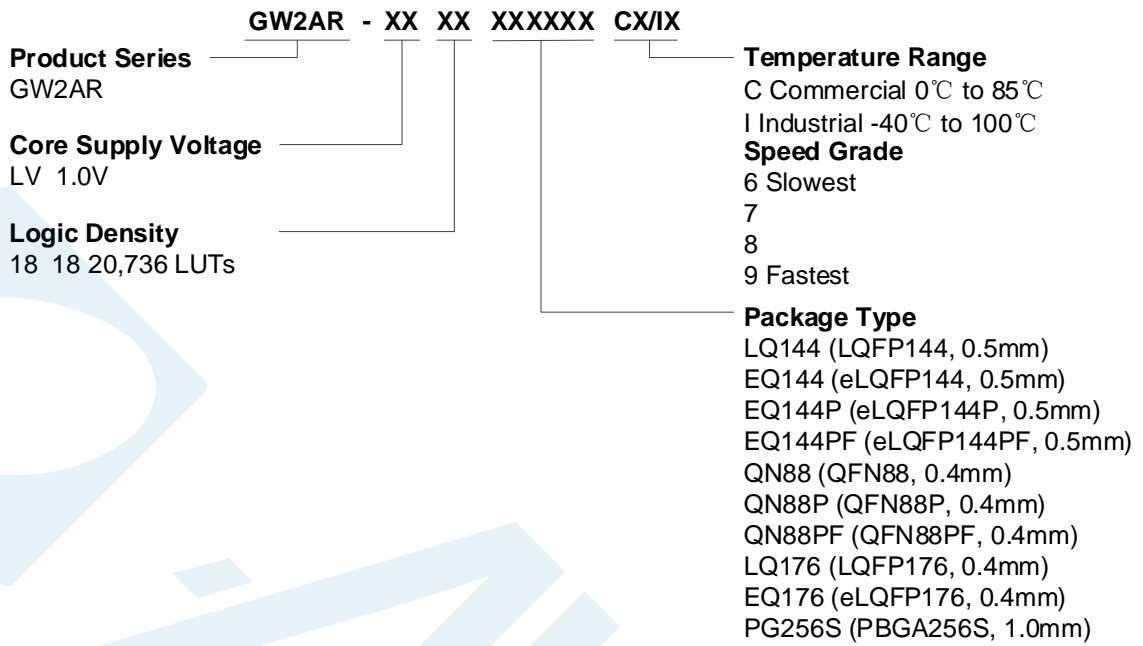

Figure 5-2 Part Naming of Devices with PSRAM Embedded-Production



5.2 Package Mark

The device information of GOWINSEMI is marked on the chip surface, as shown in Figure 5-3.

Figure 5-3 Package Mark



Note!

- [1] The first two lines in the right figure above are the "Part Number".
- [2] The Data Code is followed by a "C" for C version devices.



e - e l e c t r o n i c s

Alcom

