



GW2A series of FPGA Products (Automotive)

Data Sheet

DS208-1.5E, 2024-09-27

Copyright © 2024 Guangdong Gowin Semiconductor Corporation. All Rights Reserved.

GOWIN高云, Gowin, and GOWINSEMI are trademarks of Guangdong Gowin Semiconductor Corporation and are registered in China, the U.S. Patent and Trademark Office, and other countries. All other words and logos identified as trademarks or service marks are the property of their respective holders. No part of this document may be reproduced or transmitted in any form or by any means, electronic, mechanical, photocopying, recording or otherwise, without the prior written consent of GOWINSEMI.

Disclaimer

GOWINSEMI assumes no liability and provides no warranty (either expressed or implied) and is not responsible for any damage incurred to your hardware, software, data, or property resulting from usage of the materials or intellectual property except as outlined in the GOWINSEMI Terms and Conditions of Sale. GOWINSEMI may make changes to this document at any time without prior notice. Anyone relying on this documentation should contact GOWINSEMI for the current documentation and errata.



ACROSS
Electronics
A STELIANU COMPANY

Revision History

Date	Version	Description
09/14/2020	1.0E	Initial version published.
03/04/2021	1.1E	GW2A-55 PG484 added.
06/02/2021	1.2E	<ul style="list-style-type: none"> ● Electrical parameters optimized. ● GW2A-55 PG484 removed.
05/25/2022	1.3E	<ul style="list-style-type: none"> ● Recommended I/O operating conditions updated. ● Power supply ramp rates updated.
03/16/2023	1.4E	<ul style="list-style-type: none"> ● "Table 3-1 Absolute Max. Ratings" updated. ● "Table 3-2 Recommended Operating Conditions" updated. ● "Table 3-3 Power Supply Ramp Rates" updated. ● "Table 3-5 POR Parameters" updated. ● "Table 3-8 DC Electrical Characteristics over Recommended Operating Conditions" updated. ● The maximum value of the differential input threshold V_{THD} updated. ● Note about DC current limit added. ● "Figure 2-1 Architecture Overview" updated. ● "3.4.4 Byte-enable" removed. ● Information on Slew Rate removed. ● Note about the default state of GPIOs modified.
09/27/2024	1.5E	<ul style="list-style-type: none"> ● Editorial updates. ● "Table 1-1 Product Resources" updated. ● The I/O logic output diagram and the I/O logic input diagram combined into "Figure 2-5 I/O Logic Input and Output". ● Note about ripples added to "Table 3-2 Recommended Operating Conditions". ● Note for "Table 3-8 DC Electrical Characteristics over Recommended Operating Conditions" modified. ● "Table 3-16 Gearbox Timing Parameters" added. ● "Table 3-17 External Switching Characteristics" updated. ● "Table 3-18 On-chip Oscillator Switching Characteristics" updated. ● "2.4.2 Memory Configuration Modes" updated. ● "Figure 4-2 Package Marking Examples" updated. ● Note about default state of GPIOs optimized. ● "2.4.6 Power up Conditions" removed. ● Description of IODELAY module updated. ● Description of DES module optimized.

Contents

Contents	i
List of Figures	iii
List of Tables	iv
1 General Description	1
1.1 Features	1
1.2 Product Resources	2
2 Architecture	3
2.1 Architecture Overview	3
2.2 Configurable Function Units	4
2.3 Input/Output Blocks	5
2.3.1 I/O Standards	6
2.3.2 I/O Logic	11
2.3.3 I/O Logic Modes	14
2.4 Block SRAM	14
2.4.1 Introduction	14
2.4.2 Memory Configuration Modes	15
2.4.3 Mixed Data Width Configuration	16
2.4.4 Parity Bit	17
2.4.5 Synchronous Operation	17
2.4.6 BSRAM Operation Modes	17
2.4.7 Clock Mode	19
2.5 Digital Signal Processing	20
2.5.1 Introduction	20
2.5.2 Macro	20
2.5.3 DSP Operation Modes	21
2.6 Clocks	21
2.6.1 Global Clocks	22
2.6.2 PLLs	22
2.6.3 High-speed Clocks	23
2.6.4 DDR Memory Interface Clock Management (DQS)	23
2.7 Long Wires	24

2.8 Global Set/Reset.....	24
2.9 Programming & Configuration	24
2.10 On-chip Oscillator	24
3 DC and Switching Characteristics	26
3.1 Operating Conditions	26
3.1.1 Absolute Max. Ratings.....	26
3.1.2 Recommended Operating Conditions	26
3.1.3 Power Supply Ramp Rates	27
3.1.4 Hot Socketing Specifications	27
3.1.5 POR Specifications.....	27
3.2 ESD performance	28
3.3 DC Electrical Characteristics	28
3.3.1 DC Electrical Characteristics over Recommended Operating Conditions	28
3.3.2 Static Current.....	29
3.3.3 Recommended I/O Operating Conditions	29
3.3.4 Single-ended I/O DC Characteristics.....	31
3.3.5 Differential I/O DC Characteristics.....	32
3.4 Switching Characteristics	32
3.4.1 CFU Switching Characteristics	32
3.4.2 BSRAM Switching Characteristics.....	33
3.4.3 DSP Switching Characteristics	33
3.4.4 Gearbox Switching Characteristics.....	33
3.4.5 Clock and I/O Switching Characteristics.....	34
3.4.6 On-chip Oscillator Switching Characteristics.....	34
3.4.7 PLL Switching Characteristics	34
3.5 Configuration Interface Timing Specification	34
4 Ordering Information.....	35
4.1 Part Naming.....	35
4.2 Package Markings	36
5 About This Manual.....	37
5.1 Purpose	37
5.2 Related Documents	37
5.3 Terminology and Abbreviations.....	37
5.4 Support and Feedback	38

List of Figures

Figure 2-1 Architecture Overview.....	3
Figure 2-2 CFU Structure View.....	5
Figure 2-3 IOB Structure View.....	6
Figure 2-4 I/O Bank Distribution View of GW2A.....	7
Figure 2-5 I/O Logic Input and Output.....	11
Figure 2-6 IODELAY Diagram.....	12
Figure 2-7 I/O Register Diagram.....	13
Figure 2-8 IEM Diagram.....	13
Figure 2-9 Pipeline Mode in Single Port Mode, Dual Port Mode, and Semi-dual Port Mode.....	18
Figure 2-10 Independent Clock Mode.....	19
Figure 2-11 Read/Write Clock Mode.....	20
Figure 2-12 Single Port Clock Mode.....	20
Figure 2-13 GW2A Clock Resources.....	22
Figure 2-14 GW2A HCLK Distribution.....	23
Figure 4-1 Part Naming – Production.....	35
Figure 4-2 Package Marking Examples.....	36

List of Tables

Table 1-1 Product Resources.....	2
Table 1-2 PLL List	2
Table 1-3 Device-Package Combinations and Maximum User I/Os (True LVDS Pairs).....	2
Table 2-1 Output I/O Standards and Configuration Options	7
Table 2-2 Input I/O Standards and Configuration Options supported by GW2A	9
Table 2-3 Port Description.....	12
Table 2-4 Total Delay of IODELAY Module	12
Table 2-5 Memory Size Configuration.....	15
Table 2-6 Dual Port Mixed Read/Write Data Width Configuration	16
Table 2-7 Semi-dual Port Mixed Read/Write Data Width Configuration	16
Table 2-8 Clock Modes in Different BSRAM Modes	19
Table 2-9 Output Frequency Options of the On-chip Oscillator	24
Table 3-1 Absolute Max. Ratings	26
Table 3-2 Recommended Operating Conditions.....	26
Table 3-3 Power Supply Ramp Rates	27
Table 3-4 Hot Socketing Specifications	27
Table 3-5 POR Parameters.....	27
Table 3-6 GW2A ESD - HBM	28
Table 3-7 GW2A ESD - CDM	28
Table 3-8 DC Electrical Characteristics over Recommended Operating Conditions.....	28
Table 3-9 Static Current	29
Table 3-10 Recommended I/O Operating Conditions.....	29
Table 3-11 Single-ended I/O DC Characteristics	31
Table 3-12 Differential I/O DC Characteristics	32
Table 3-13 CFU Timing Parameters	32
Table 3-14 BSRAM Timing Parameters	33
Table 3-15 DSP Timing Parameters.....	33
Table 3-16 Gearbox Timing Parameters	33
Table 3-17 External Switching Characteristics.....	34
Table 3-18 On-chip Oscillator Switching Characteristics	34
Table 3-19 PLL Switching Characteristics.....	34
Table 5-1 Terminology and Abbreviations	37

1 General Description

The GW2A FPGAs(Automotive) are members of the 2 series of the Arora family, featuring high-performance DSP resources, high-speed LVDS interfaces, and abundant BSRAM memory resources. These embedded resources combined with a streamlined FPGA architecture and 55nm process make the GW2A FPGAs(Automotive) an ideal solution for high-speed and low-cost applications.

GOWINSEMI provides a new generation of FPGA hardware development environment that supports FPGA synthesis, placement & routing, bitstream generation and download, etc.

1.1 Features

- Lower power consumption
 - 55nm SRAM process
 - Core voltage: 1.0V
 - Supports dynamically turning on/off the clock
- Multiple I/O standards
 - LVCMOS33/25/18/15/12; LVTTTL33,SSTL33/25/18 I, II, SSTL15; HSTL18 I, II, HSTL15 I; PCI, LVDS25, RSDS, LVDS25E, BLVDSE,MLVDSE, LVPECLE, RSDSE
 - Input hysteresis options
 - Drive strength options
 - Individual Bus Keeper, Pull-up/Pull-down, and Open Drain options
 - Hot socketing
- High-performance DSP blocks
 - High-performance digital signal processing
 - Supports 9 x 9, 18 x 18, 36 x 36 bit multipliers and 54-bit accumulators
 - Supports cascading of multipliers
 - Supports pipeline mode and bypass mode
 - Pre-addition operation for the filter function
 - Supports barrel shifters
- Abundant basic logic cells
 - 4-input LUTs (LUT4s)
 - Supports shift registers and shadow SRAMs
- Block SRAMs with multiple modes
 - Supports Dual Port mode, Single Port mode, and Semi-Dual Port mode
- Flexible PLLs
 - Frequency adjustment (multiplication and division) and phase adjustment
 - Supports global clocks
- Configuration

- JTAG configuration
- Four GowinCONFIG configuration modes: SSPI, MSPI, CPU, SERIAL
- Supports programming the SPI Flash directly in JTAG and SSPI modes; For other modes, you can program the SPI Flash using an IP
- Supports bitstream file encryption and security bit settings

1.2 Product Resources

Table 1-1 Product Resources

Device	GW2A-18
LUT4s	20,736
Flip-Flops (FFs)	15,552
Shadow SRAM (SSRAM) Capacity (bits)	40K
Block SRAM (BSRAM) Capacity (bits)	828K
Number of BSRAMs	46
Multipliers (18 x 18 Multipliers)	48
Maximum PLLs ^[1]	4
I/O Banks	8
Maximum GPIOs ^[2]	384
Core voltage	1.0V

Note!

- ^[1] Different packages support different numbers of PLLs. Up to four PLLs can be supported.
- ^[2] This is the maximum number of GPIOs the device can provide without package limitation. Please refer to Table 1-3 for the maximum number of user I/Os available for the specific packages.

Table 1-2 PLL List

Package	Device	Available PLLs
QN88	GW2A-18	PLLL1/PLLR1
PG256	GW2A-18	PLLL/PLLR

Table 1-3 Device-Package Combinations and Maximum User I/Os (True LVDS Pairs)

Package	Pitch (mm)	Size (mm)	E-pad Size (mm)	GW2A-18
QN88	0.4	10 x 10	6.74 x 6.74	66 (22)
PG256	1.0	17 x 17	–	207 (73)

Note!

- The package types in this manual are referred to by acronyms, see 4.1 Part Naming for more information.

- JTAGSEL_N and JTAG pins cannot be used as GPIOs simultaneously. The number of maximum user I/Os noted in this table is referred to when the four JTAG pins (TCK, TDI, TDO, and TMS) are used as GPIOs. See [UG111, GW2A series of FPGA Products Package and Pinout](#) for more details.
- The speed of the JTAG pins multiplexed as GPIOs is less than 40MHz.



2 Architecture

2.1 Architecture Overview

Figure 2-1 Architecture Overview

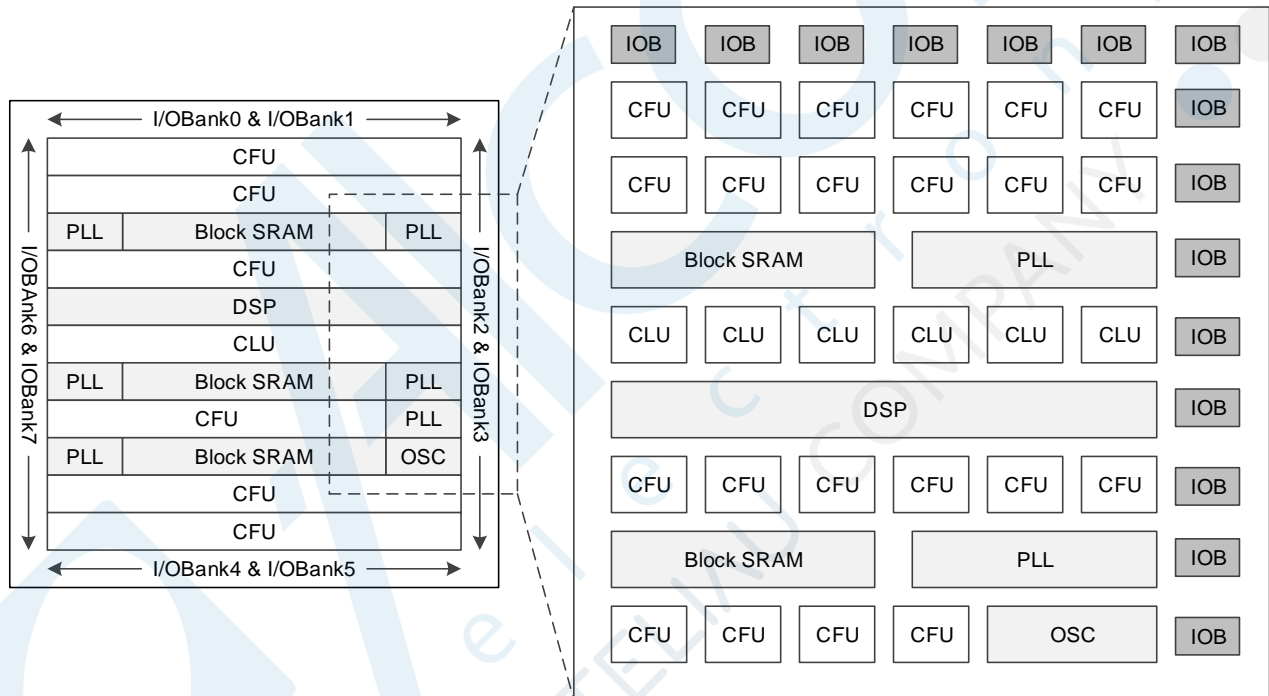

Figure 2-1 shows an overview of the architecture of the GW2A series of FPGA products (Automotive), see Table 1-1 for more information. The core of the FPGA is an array of logic cells surrounded by IO blocks. Besides, BSRAMs, DSP blocks, PLLs, and an on-chip oscillator are provided.

The Configurable Function Unit (CFU) and the Configurable Logic Unit (CLU) are the two kinds of basic logic blocks that form the core of Gowin FPGAs. Devices with different capacities have different numbers of rows and columns of CFUs/CLUs. For more information, see [2.2 Configurable Function Units](#).

The I/O resources in the GW2A series of FPGA products (Automotive) are arranged around the periphery of the devices in groups referred to as banks, which are divided into eight banks, including Bank0 - Bank7. The I/O resources support multiple I/O standards and can be used for regular mode, SDR mode, generic DDR mode, and DDR_MEM mode. For more information, see [2.3 Input/Output Blocks](#).

BSRAMs are arranged in row(s) inside the GW2A series of FPGA products (Automotive). Each BSRAM occupies 3 CFU locations. Each BSRAM has a capacity of 18 Kbits and supports multiple configuration modes and operation modes. For more information, see [2.4 Block SRAM](#).

The GW2A series of FPGA products (Automotive) provide DSP blocks. DSP blocks are arranged in row(s) inside the GW2A series of FPGA products. Each DSP block occupies 9 CFU locations. Each DSP block contains two macros, and each macro contains two pre-adders, two 18 x 18 bit multipliers, and one three-input ALU. For more information, see [2.5 Digital Signal Processing](#).

The GW2A series of FPGA products(Automotive) have embedded PLL resources. The PLLs can provide synthesizable clock frequencies. Frequency adjustment (multiplication and division), phase adjustment, and duty cycle adjustment can be realized by configuring the parameters. These FPGAs also have an embedded programmable on-chip clock oscillator that supports clock frequencies ranging from 2.5 MHz to 125MHz, providing clocking resources for the MSPI mode. For more information, see [2.10 On-chip Oscillator](#).

There are also abundant Configurable Routing Units (CRUs) that interconnect all the resources within the FPGA. For example, routing resources distributed in CFUs and IOBs interconnect resources in them. Routing resources can be automatically generated by the Gowin software. In addition, the GW2A series of FPGA products(Automotive) also provide abundant dedicated clock resources, long wires (LWs), global set/reset (GSR) resources, programming options, etc. For more details, see [2.5.3 DSP Operation Modes](#), [2.7 Long Wires](#), and [2.8 Global Set/Reset](#).

2.2 Configurable Function Units

Configurable Function Units (CFUs) and/or Configurable Logic Units (CLUs) are the basic cells that make up the core of Gowin FPGAs. Each basic cell consists of four Configurable Logic Sections (CLSs) and their routing resource Configurable Routing Units (CRUs), with three of the CLSs each containing two 4-input LUTs and two registers, and the remaining one only containing two 4-input LUTs, as shown in Figure 2-2 .

The CLSs in the CLUs cannot be configured as SRAMs, but can be configured as basic LUTs, ALUs, and ROMs. The CLSs in the CFUs can be configured as basic LUTs, ALUs, SRAMs, and ROMs according to application scenarios.

For more information on the CFUs, see [UG288, Gowin Configurable Function Unit \(CFU\) User Guide](#).

Figure 2-2 CFU Structure View

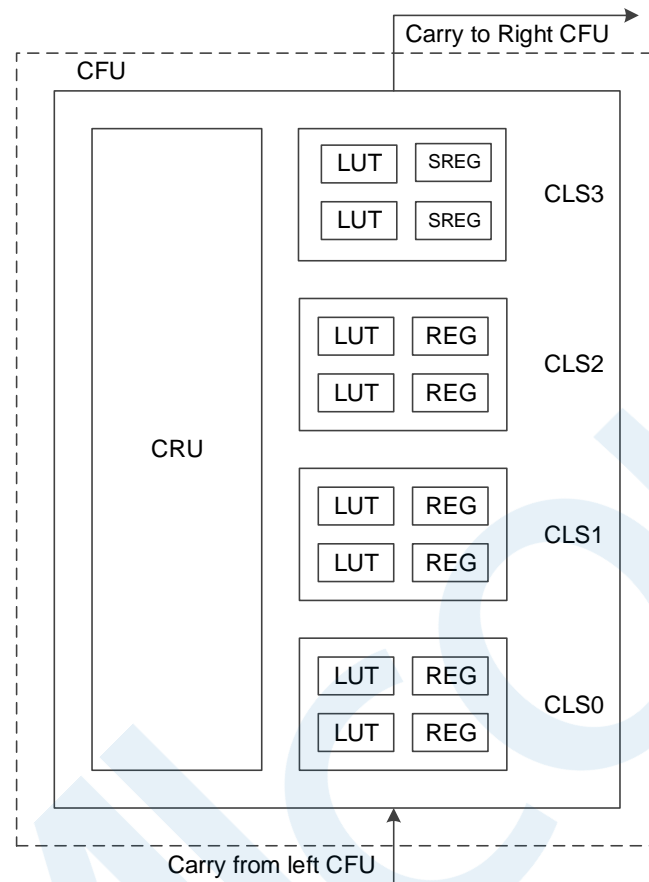
**Note!**

The SREGs need special patch support. Please contact Gowin's technical support or local office for this patch.

2.3 Input/Output Blocks

The Input/Output Block (IOB) in the GW2A series of FPGA products (Automotive) consists of a buffer pair, IO logic, and corresponding routing units. As shown below, each IOB connects to two pins (marked as A and B), which can be used as a differential pair or as two single-ended inputs/outputs.

Figure 2-3 IOB Structure View

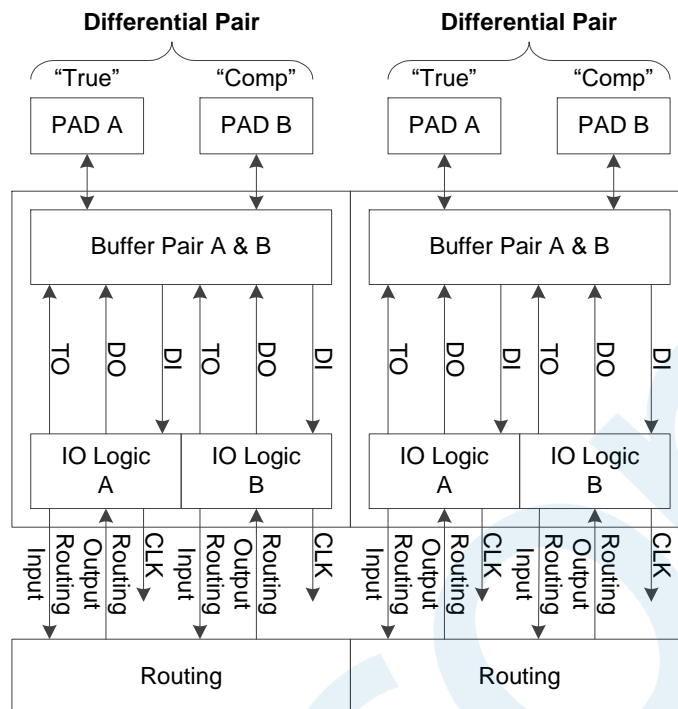

The features of the IOB include:

- V_{CCIO} supplied to each bank
- LVCMOS, PCI, LVTTTL, LVDS, SSTL, HSTL, etc.
- Input hysteresis options
- Drive strength options
- Individual Bus Keeper, Pull-up/Pull-down, and Open Drain options
- Hot socketing
- IO logic supports basic mode, SDR mode, DDR mode, etc.

2.3.1 I/O Standards

There are eight I/O banks in the GW2A series of FPGA products (Automotive), as shown in Figure 2-4. Each bank has its own I/O power supply V_{CCIO} . V_{CCIO} can be 3.3V, 2.5V, 1.8V, 1.5V, or 1.2V. $V_{CCIO2/6}$ and V_{CCX} of the QN88 package are internally tied together, and the supply voltage can be set to 2.7V or 3.3V. Please refer to Table 3-2 for details. To support SSTL, HSTL, etc., Each bank also has one independent voltage source (V_{REF}) as the reference voltage. You can choose to use the internal V_{REF} ($0.5 \times V_{CCIO}$) or the external V_{REF} input via any IO from the bank. V_{CCX} supports 2.7V and 3.3V.

Figure 2-4 I/O Bank Distribution View of GW2A

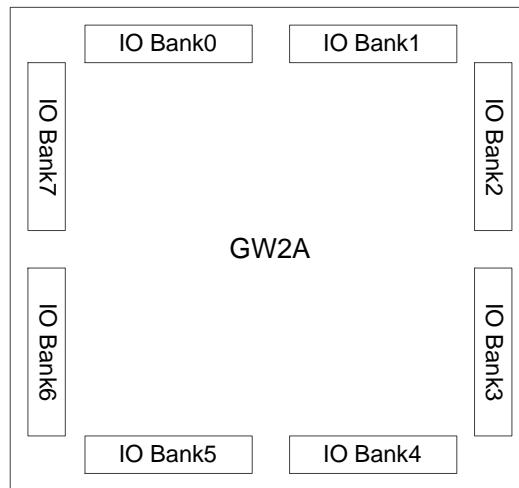

Different banks in the GW2A series of FPGA Products (Automotive) support different on-die termination settings, including single-ended resistors and differential resistors. Single-ended resistors are set for SSTL/HSTL input/output and are supported in Bank2/3/6/7. Differential resistors are set for LVDS input and are only supported in Bank 0/1. For more information, please refer to [UG289, Gowin Programmable IO User Guide](#).

Note!

During configuration, all GPIOs of the device are high-impedance with internal weak pull-ups. After the configuration is complete, the I/O states are controlled by user programs and constraints. The states of configuration-related I/Os differ depending on the configuration mode.

For the V_{CCIO} requirements of different I/O standards, see Table2-1.

Table2-1 Output I/O Standards and Configuration Options

I/O standard (output)	Single-ended/Differential	Bank V_{CCIO} (V)	Drive Strength (mA)	Typical Applications
LVTTTL33	Single-ended	3.3	8/24/16/12/4	Universal interface
LVC MOS33	Single-ended	3.3	8/24/16/12/4	Universal interface
LVC MOS25	Single-ended	2.5	8/16/12/4	Universal interface
LVC MOS18	Single-ended	1.8	8/12/4	Universal interface
LVC MOS15	Single-ended	1.5	8/4	Universal interface
LVC MOS12	Single-ended	1.2	8/4	Universal interface
SSTL25_I	Single-ended	2.5	8	Memory interface
SSTL25_II	Single-ended	2.5	8	Memory interface

I/O standard (output)	Single-ended/Differential	Bank V _{CCIO} (V)	Drive Strength (mA)	Typical Applications
SSTL33_I	Single-ended	3.3	8	Memory interface
SSTL33_II	Single-ended	3.3	8	Memory interface
SSTL18_I	Single-ended	1.8	8	Memory interface
SSTL18_II	Single-ended	1.8	8	Memory interface
SSTL15	Single-ended	1.5	8	Memory interface
HSTL18_I	Single-ended	1.8	8	Memory interface
HSTL18_II	Single-ended	1.8	8	Memory interface
HSTL15_I	Single-ended	1.5	8	Memory interface
PCI33	Single-ended	3.3	N/A	PC and embedded system
LVPECL33E	Differential	3.3	16	High-speed data transmission
MLVDS25E	Differential	2.5	16	LCD timing driver interface and column driver interface
BLVDS25E	Differential	2.5	16	Multi-point high-speed data transmission
RSDS25E	Differential	2.5	8	High-speed point-to-point data transmission
LVDS25E	Differential	2.5	8	High-speed point-to-point data transmission
LVDS25	Differential(TL VDS)	2.5/3.3	3.5/2.5/2/1.25	High-speed point-to-point data transmission
RSDS	Differential(TL VDS)	2.5/3.3	2	High-speed point-to-point data transmission
MINILVDS	Differential(TL VDS)	2.5/3.3	2	LCD timing driver interface and column driver interface
PPLVDS	Differential(TL	2.5/3.3	3.5	LCD row/column

I/O standard (output)	Single-ended/ Differential	Bank V _{CCIO} (V)	Drive Strength (mA)	Typical Applications
	VDS)			driver
SSTL15D	Differential	1.5	8	Memory interface
SSTL25D_I	Differential	2.5	8	Memory interface
SSTL25D_II	Differential	2.5	8	Memory interface
SSTL33D_I	Differential	3.3	8	Memory interface
SSTL33D_II	Differential	3.3	8	Memory interface
SSTL18D_I	Differential	1.8	8	Memory interface
SSTL18D_II	Differential	1.8	8	Memory interface
HSTL18D_I	Differential	1.8	8	Memory interface
HSTL18D_II	Differential	1.8	8	Memory interface
HSTL15D_I	Differential	1.5	8	Memory interface
LVC MOS12 D	Differential	1.2	8/4	Universal interface
LVC MOS15 D	Differential	1.5	8/4	Universal interface
LVC MOS18 D	Differential	1.8	8/12/4	Universal interface
LVC MOS25 D	Differential	2.5	8/16/12/4	Universal interface
LVC MOS33 D	Differential	3.3	8/24/16/12/4	Universal interface

Table 2-2 Input I/O Standards and Configuration Options supported by GW2A

I/O standard (input)	Single-ended/ Differential	Bank V _{CCIO} (V)	Hysteresis Options Supported?	V _{REF} Required?
LVTTTL33	Single-ended	1.5/1.8/2.5/3.3	Yes	No
LVC MOS33	Single-ended	1.5/1.8/2.5/3.3	Yes	No
LVC MOS25	Single-ended	1.5/1.8/2.5/3.3	Yes	No
LVC MOS18	Single-ended	1.5/1.8/2.5/3.3	Yes	No
LVC MOS15	Single-ended	1.2/1.5/1.8/2.5/3.3	Yes	No
LVC MOS12	Single-ended	1.2/1.5/1.8/2.5/3.3	Yes	No
SSTL15	Single-ended	1.5/1.8/2.5/3.3	No	Yes
SSTL25_I	Single-ended	2.5/3.3	No	Yes
SSTL25_II	Single-ended	2.5/3.3	No	Yes

I/O standard (input)	Single-ended/ Differential	Bank V _{CCIO} (V)	Hysteresis Options Supported?	V _{REF} Required?
SSTL33_I	Single-ended	3.3	No	Yes
SSTL33_II	Single-ended	3.3	No	Yes
SSTL18_I	Single-ended	1.8/2.5/3.3	No	Yes
SSTL18_II	Single-ended	1.8/2.5/3.3	No	Yes
HSTL18_I	Single-ended	1.8/2.5/3.3	No	Yes
HSTL18_II	Single-ended	1.8/2.5/3.3	No	Yes
HSTL15_I	Single-ended	1.5/1.8/2.5/3.3	No	Yes
PCI33	Single-ended	3.3	Yes	No
LVC MOS33OD25	Single-ended	2.5	No	No
LVC MOS33OD18	Single-ended	1.8	No	No
LVC MOS33OD15	Single-ended	1.5	No	No
LVC MOS25OD18	Single-ended	1.8	No	No
LVC MOS25OD15	Single-ended	1.5	No	No
LVC MOS18OD15	Single-ended	1.5	No	No
LVC MOS15OD12	Single-ended	1.2	No	No
LVC MOS25UD33	Single-ended	3.3	No	No
LVC MOS18UD25	Single-ended	2.5	No	No
LVC MOS18UD33	Single-ended	3.3	No	No
LVC MOS15UD18	Single-ended	1.8	No	No
LVC MOS15UD25	Single-ended	2.5	No	No
LVC MOS15UD33	Single-ended	3.3	No	No
LVC MOS12UD15	Single-ended	1.5	No	No
LVC MOS12UD18	Single-ended	1.8	No	No
LVC MOS12UD25	Single-ended	2.5	No	No
LVC MOS12UD33	Single-ended	3.3	No	No
LVDS25	Differential	2.5/3.3	No	No
RSDS	Differential	2.5/3.3	No	No
MINILVDS	Differential	2.5/3.3	No	No
PPLVDS	Differential	2.5/3.3	No	No
LVDS25E	Differential	2.5/3.3	No	No
MLVDS25E	Differential	2.5/3.3	No	No
BLVDS25E	Differential	2.5/3.3	No	No
RSDS25E	Differential	2.5/3.3	No	No
LVPECL33E	Differential	3.3	No	No
SSTL15D	Differential	1.5/1.8/2.5/3.3	No	No
SSTL25D_I	Differential	2.5/3.3	No	No
SSTL25D_II	Differential	2.5/3.3	No	No
SSTL33D_I	Differential	3.3	No	No

I/O standard (input)	Single-ended/ Differential	Bank V _{CCIO} (V)	Hysteresis Options Supported?	V _{REF} Required?
SSTL33D_II	Differential	3.3	No	No
SSTL18D_I	Differential	1.8/2.5/3.3	No	No
SSTL18D_II	Differential	1.8/2.5/3.3	No	No
HSTL18D_I	Differential	1.8/2.5/3.3	No	No
HSTL18D_II	Differential	1.8/2.5/3.3	No	No
HSTL15D_I	Differential	1.5/1.8/2.5/3.3	No	No
LVC MOS12D	Differential	1.2/1.5/1.8/2.5/3.3	No	No
LVC MOS15D	Differential	1.5/1.8/2.5/3.3	No	No
LVC MOS18D	Differential	1.8/2.5/3.3	No	No
LVC MOS25D	Differential	2.5/3.3	No	No
LVC MOS33D	Differential	3.3	No	No

2.3.2 I/O Logic

Figure 2-5 shows the I/O logic input and output of the GW2A series of FPGA products(Automotive).

Figure 2-5 I/O Logic Input and Output

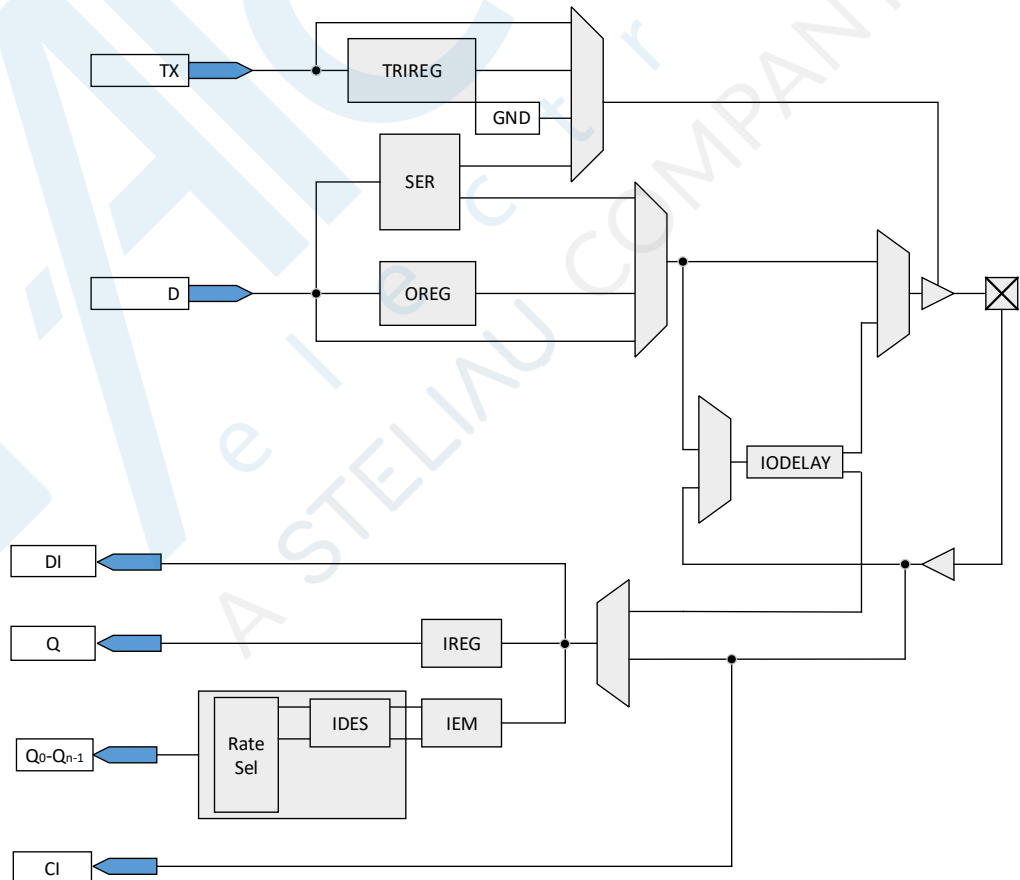

Table 2-3 Port Description

Port	I/O	Description
CI ^[1]	Input	GCLK input signal. For the number of GCLK input signals, please refer to UG110, GW2A-18 Pinout .
DI	Input	IO port low-speed input signal input into the fabric directly.
Q	Output	IREG output signal in the SDR module.
Q ₀ -Q _{n-1}	Output	IDES output signal in the DDR module.

Note!

^[1] When CI is used as GCLK input, DI, Q, and Q₀-Q_{n-1} cannot be used as I/O input and output.

Descriptions of the I/O logic modules of the GW2A series of FPGA products (Automotive) are presented below.

IODELAY

See Figure 2-6 for an overview of the IODELAY module. Each I/O of the GW2A series of FPGA products (Automotive) contains the IODELAY module, through which you can add additional delays to the I/O to adjust the delay of the signal. The delay time of each step is T_{dlyunit}, and the number of steps is DLYSTEP. The total delay time of IODELAY can be calculated as follows: T_{totdly} = T_{dlyoffset} + T_{dlyunit} * DLYSTEP. See Table 2-4 for the total delay time.

Table 2-4 Total Delay of IODELAY Module

	Min.	Typ.	Max.
T _{dlyoffset}	300ps	350ps	400ps
T _{dlyunit}	-	18ps	-
DLYSTEP	0	-	127

Figure 2-6 IODELAY Diagram

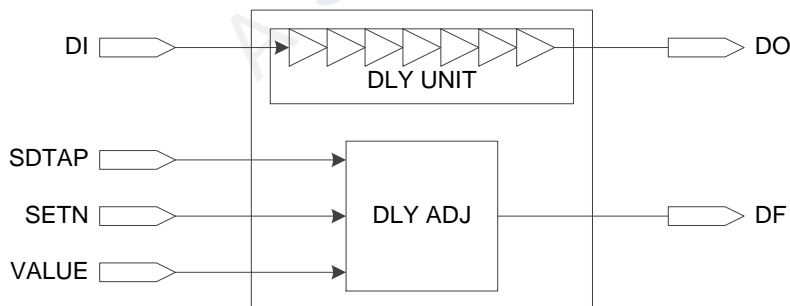

There are two ways to control the delay:

- Static control.
- Dynamic control: can be used with the IEM module to adjust the dynamic sampling window. Please note the IODELAY module cannot be used for both input and output at the same time.

I/O Register

See Figure 2-7 for the I/O register in the GW2A series of FPGA products(Automotive). Each I/O provides one input register (INFF), one output register (OUTFF), and one tristate register (TCFF).

Figure 2-7 I/O Register Diagram

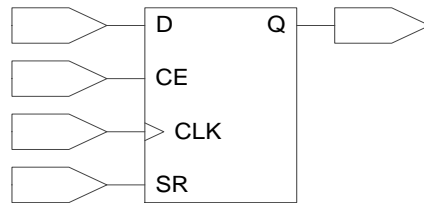

Note!

- CE can be programmed as either active low (0: enable) or active high (1: enable).
- CLK can be programmed as either rising edge triggering or falling edge triggering.
- SR can be programmed as either synchronous/asynchronous SET/RESET or disabled.
- The register can be programmed as a register or a latch.

IEM

The IEM (Input Edge Monitor) module is used to sample data edges and is used in generic DDR mode, as shown in Figure 2-8.

Figure 2-8 IEM Diagram



Deserializer(DES) and Clock Domain Transfer

This series of FPGA products provide a simple deserializer(DES) for input I/O logic to support advanced I/O protocols. The clock domain transfer module in DES provides the ability to safely switch the external sampling clock (strobe) domain to the internal continuously running clock domain. There are multiple registers used for data sampling.

The clock domain transfer module offers the following functions:

- Uses the internal continuous clock instead of the discontinuous DQS signal for data sampling. This feature applies to the DDR memory interface.
- For the DDR3 memory interface standard, aligns the DQS signal and

data by read leveling.

- In generic DDR mode, when DQS.RCLK is used for sampling, the clock domain transfer module is also required.

Each DQS module provides WADDR and RADDR signals for the clock domain transfer modules in the same group.

SER

This series of FPGA products provide a simple serializer(SER) for output I/O logic to support advanced I/O protocols.

2.3.3 I/O Logic Modes

The I/O Logic of the GW2A series of FPGA products(Automotive) supports several operation modes. In each operation mode, the I/O (or I/O differential pair) can be configured as output, input, INOUT or tristate output (output signal with tristate control).

For more information about I/O logic modes, please refer to [UG289, Gowin Programmable IO User Guide](#).

2.4 Block SRAM

2.4.1 Introduction

The GW2A series of FPGA products(Automotive) provide abundant block SRAM resources. These memory resources are distributed as blocks throughout the FPGA array in the form of rows. Therefore, they are called block static random access memories (BSRAMs). Each BSRAM block occupies 3 CFU locations. The capacity of each BSRAM can be up to 18,432 bits (18 Kbits). There are five configuration modes: Single Port mode, Dual Port mode, Semi-Dual Port mode, ROM mode, and FIFO mode.

The abundant BSRAM resources are available for implementing high-performance designs. The features of BSRAMs include:

- Up to 18,432 bits per BSRAM
- Clock frequency up to 380MHz (230MHz in Read-before-write mode)
- Supports Single Port mode
- Supports Dual Port mode
- Supports Semi-Dual Port mode
- Provides parity bits
- Supports ROM Mode
- Data widths from 1 to 36 bits
- Mixed Cock mode
- Mixed Data Width mode
- Normal Read and Write
- Read-before-write
- Write-through

2.4.2 Memory Configuration Modes

BSRAMs in the GW2A series of FPGA products(Automotive) support various data widths, see Table 2-5.

Table 2-5 Memory Size Configuration

Single Port Mode	Dual Port Mode	Semi-Dual Port Mode	ROM Mode
16K x 1	16K x 1	16K x 1	16K x 1
8K x 2	8K x 2	8K x 2	8K x 2
4K x 4	4K x 4	4K x 4	4K x 4
2K x 8	2K x 8	2K x 8	2K x 8
1K x 16	1K x 16	1K x 16	1K x 16
512 x 32	-	512 x 32	512 x 32
2K x 9	2K x 9	2K x 9	2K x 9
1K x 18	1K x 18	1K x 18	1K x 18
512 x 36	-	512 x 36	512 x 36

Single Port Mode

The single port mode supports 2 read modes (bypass mode and pipeline mode) and 3 write modes (normal mode, write-through mode, and read-before-write mode). In single port mode, writing to or reading from one port at one clock edge is supported. During the write operation, the written data will be transferred to the output of the BSRAM. When the output register is bypassed, the new data will show up at the same write clock rising edge.

For more information on single port mode, please refer to [UG285, Gowin BSRAM & SSRAM User Guide](#).

Dual Port Mode

The Dual Port mode supports 2 read modes (Bypass mode and Pipeline mode) and 2 write modes (Normal mode and Write-through mode). The applicable operations are as follows:

- Two independent read operations
- Two independent write operations
- An independent read operation and an independent write operation

Note!

Performing read and write operations to the same address at the same time is not allowed.

For more information on dual port mode, please refer to [UG285, Gowin BSRAM & SSRAM User Guide](#).

Semi-Dual Port Mode

The semi-dual port mode supports 2 read modes (Bypass mode and Pipeline mode) and 1 write mode (Normal mode). Semi-dual Port mode supports simultaneous read and write operations in the form of writing to

port A and reading from port B.

Note!

Performing read and write operations to the same address at the same time is not allowed.

For more information on semi-dual port mode, please refer to [UG285, Gowin BSRAM & SSRAM User Guide](#).

ROM Mode

BSRAMs can be configured as ROMs. The ROM can be initialized during the device configuration stage, and the ROM data needs to be provided in the initialization file. Initialization is completed during the device power-on process.

Each BSRAM can be configured as one 16Kbit ROM. For more information on ROM mode, please refer to [UG285, Gowin BSRAM & SSRAM User Guide](#).

2.4.3 Mixed Data Width Configuration

The BSRAMs in the GW2A series of FPGA products(Automotive) support mixed data width operations. In dual port mode and semi-dual port mode, the data widths for read and write can be different, see Table 2-6 and Table 2-7.

Table 2-6 Dual Port Mixed Read/Write Data Width Configuration

Read Port	Write Port						
	16K x 1	8K x 2	4K x 4	2K x 8	1K x 16	2K x 9	1K x 18
16K x 1	*	*	*	*	*		
8K x 2	*	*	*	*	*		
4K x 4	*	*	*	*	*		
2K x 8	*	*	*	*	*		
1K x 16	*	*	*	*	*		
2K x 9						*	*
1K x 18						*	*

Note!

“*” denotes the modes supported.

Table 2-7 Semi-dual Port Mixed Read/Write Data Width Configuration

Read Port	Write Port								
	16K x 1	8K x 2	4K x 4	2K x 8	1K x 16	512x32	2K x 9	1K x 18	512x36
16K x 1	*	*	*	*	*	*			
8K x 2	*	*	*	*	*	*			
4K x 4	*	*	*	*	*	*			
2K x 8	*	*	*	*	*	*			

Read Port	Write Port								
	16K x 1	8K x 2	4K x 4	2K x 8	1K x 16	512x32	2K x 9	1K x 18	512x36
1K x 16	*	*	*	*	*	*			
512x32	*	*	*	*	*	*			
2K x 9							*	*	*
1K x 18							*	*	*

Note!

“*” denotes the modes supported.

2.4.4 Parity Bit

There are parity bits in BSRAMs. The 9th bit in each byte can be used as a parity bit to check the correctness of data transmission. It can also be used for data storage.

2.4.5 Synchronous Operation

- All the input registers of BSRAMs support synchronous write.
- The output registers can be used as pipeline registers to improve design performance.
- The output registers are bypass-able.

2.4.6 BSRAM Operation Modes

The BSRAM supports five different operations, including two read modes (Bypass mode and Pipeline mode) and three write modes (Normal mode, Write-Through mode, and Read-before-Write mode).

Read Mode

The following two read modes are supported.

PIPELINE MODE

When a synchronous write cycles into a memory array with pipeline registers enabled, the data can be read from pipeline registers in the next clock cycle. The data bus can be up to 36 bits in this mode.

BYPASS MODE

When a synchronous write cycles into a memory array with pipeline registers bypassed, the outputs are registered at the memory array.

Figure 2-9 Pipeline Mode in Single Port Mode, Dual Port Mode, and Semi-dual Port Mode

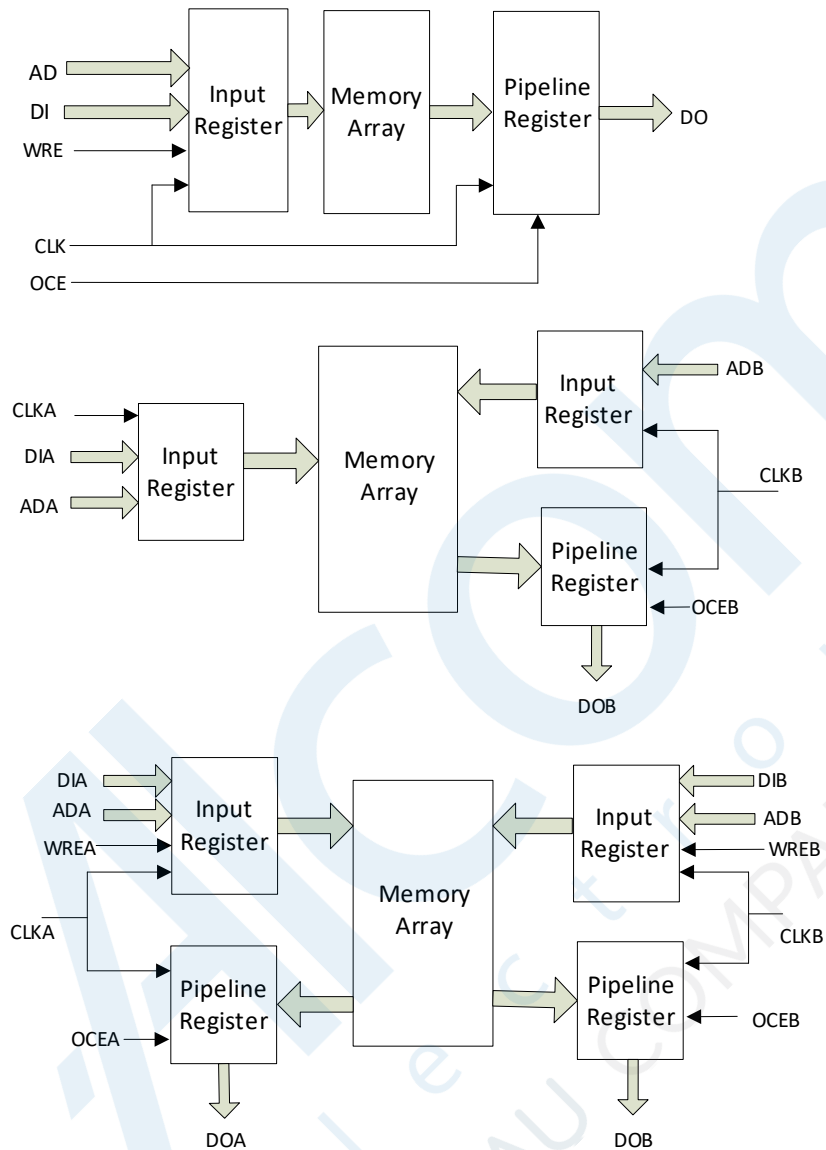

Write Mode

NORMAL MODE

In this mode, when you write data to one port, the output data of this port does not change. The written data will not appear at the read port.

WRITE-THROUGH MODE

In this mode, when you write data to one port, the written data will appear at the output of this port.

READ-BEFORE-WRITE MODE

In this mode, when you write data to one port, the written data will be stored in the memory according to the address, and the original data in this address will appear at the output of this port.

2.4.7 Clock Mode

Table 2-8 lists the clock modes in different BSRAM modes:

Table 2-8 Clock Modes in Different BSRAM Modes

Clock Mode	BSRAM Mode		
	Dual Port Mode	Semi-Dual Port Mode	Single Port Mode
Independent Clock Mode	Yes	No	No
Read/Write Clock Mode	Yes	Yes	No
Single Port Clock Mode	No	No	Yes

Independent Clock Mode

Figure 2-10 shows the independent clocking operations in dual port mode with one clock at each port. CLKA controls all the registers at Port A; CLKB controls all the registers at Port B.

Figure 2-10 Independent Clock Mode

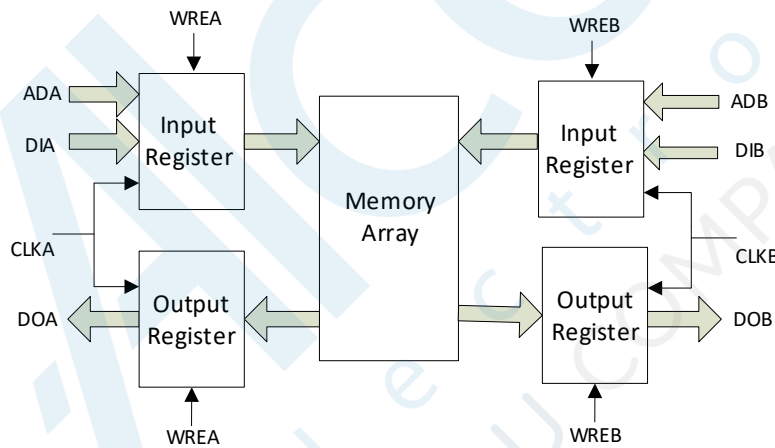

Read/Write Clock Mode

Figure 2-11 shows the read/write clocking operations in semi-dual port mode with one clock at each port. The write clock (CLKA) controls data inputs, write addresses and read/write enable signals of Port A. The read clock (CLKB) controls data outputs, read addresses, and read enable signals of Port B.

Figure 2-11 Read/Write Clock Mode

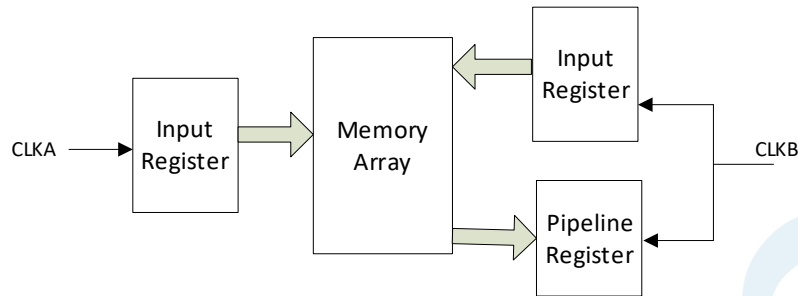

Single Port Clock Mode

Figure 2-12 shows the clocking operation in single port mode.

Figure 2-12 Single Port Clock Mode

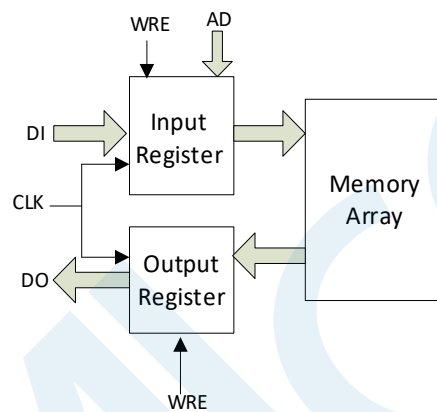

2.5 Digital Signal Processing

2.5.1 Introduction

GW2A devices (Automotive) provide abundant DSP resources. Gowin's DSP solutions can address high-performance digital signal processing needs such as FIR and FFT designs. The DSP resources have the advantages of stable timing performance, high resource utilization, and low power consumption.

The DSP resources offer the following functions:

- Multipliers with three widths: 9-bit, 18-bit, 36-bit
- 54-bit ALU
- Multipliers cascading to support wider data widths
- Barrel shifters
- Adaptive filtering through signal feedback
- Computing with options to round to a positive number or a prime number
- Supports pipeline mode and bypass mode.

2.5.2 Macro

The DSP blocks are distributed throughout the FPGA array in the form

of rows. Each DSP block occupies 9 CFU locations. Each DSP block contains two macros, and each macro contains two pre-adders, two 18 x 18 bit multipliers, and one three-input ALU.

Pre-adder

Each DSP macro contains two pre-adders for implementing pre-addition, pre-subtraction, and shifting.

The pre-adders are located at the first stage and have two input ports:

- Parallel 18-bit input B or SBI
- Parallel 18-bit input A or SIA

Each input port supports pipeline mode and bypass mode.

Gowin's pre-adders can be used independently as function blocks, which support 9-bit and 18-bit widths.

Multiplier

The multipliers are located after the pre-adders. The multipliers can be configured as 9 x 9, 18 x 18, 36 x 18, or 36 x 36. Register mode and bypass mode are supported in both input and output ports. The configuration modes that a macro supports include:

- One 18 x 36 multiplier
- Two 18 x 18 multipliers
- Four 9 x 9 multipliers

Two macros can form one 36 x 36 multiplier.

Arithmetic Logic Unit

Each DSP macro contains one 54-bit ALU, which can further enhance multipliers' functions. Register mode and bypass mode are supported in both input and output ports. The functions include:

- Addition/subtraction operations of multiplier output data/0, data A, and data B
- Addition/subtraction operations of multiplier output data/0, data B, and carry C
- Addition/subtraction operations of data A, data B, and carry C

2.5.3 DSP Operation Modes

- Multiplier mode
- Multiply accumulator mode
- Multiply-add accumulator mode

For more information on the DSP resources, see [UG287, Gowin Digital Signal Processing \(DSP\) User Guide](#).

2.6 Clocks

The clock resources and wiring are critical for high-performance applications in FPGA. The GW2A series of FPGA products(Automotive) provide global clocks (GCLKs) which connect to all the registers directly. In addition, high-speed clocks (HCLKs), PLLs, DQSSs, etc. are provided.

Figure 2-13 GW2A Clock Resources

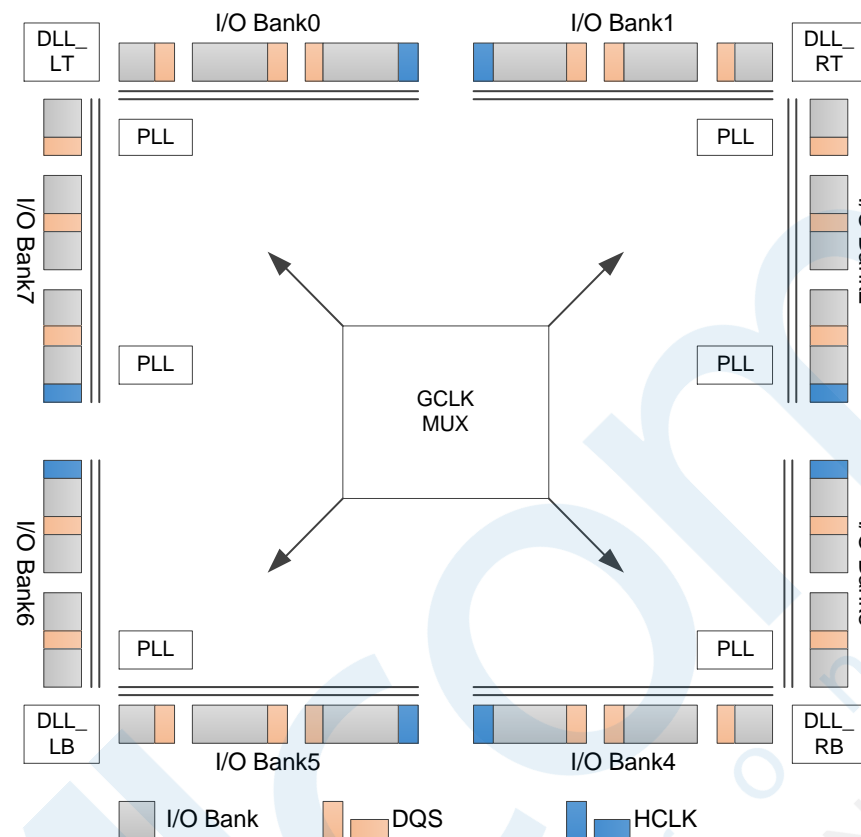

2.6.1 Global Clocks

The Global Clock (GCLK) resources are distributed in the device as four quadrants. Each quadrant provides eight GCLKs. The clock sources of GCLKs include dedicated clock input pins and CRUs, and better clock performance can be achieved by using the dedicated clock input pins.

2.6.2 PLLs

The PLL (Phase-locked Loop) is a feedback control circuit. The frequency and phase of the internal oscillator signal are controlled by the external input reference clock.

PLLs in the GW2A series of FPGA products can provide synthesizable clock frequencies. Frequency adjustment (multiplication and division), phase adjustment, and duty cycle adjustment can be achieved by configuring the parameters.

2.6.3 High-speed Clocks

The high-speed clocks (HCLKs) are designed to facilitate high-performance I/O data transmission and are specifically tailored for source synchronous data transmission protocols, see Figure 2-14.

Figure 2-14 GW2A HCLK Distribution

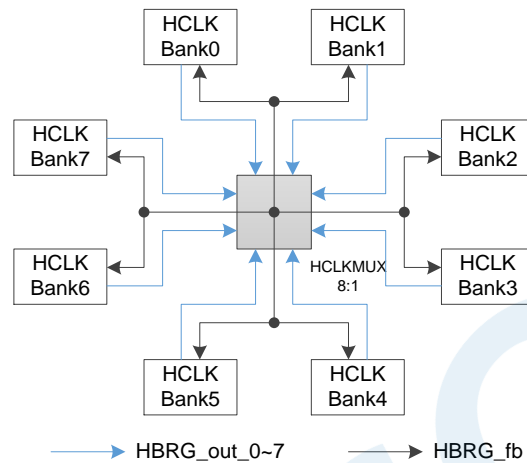

As shown in Figure 2-14, there is an 8:1 HCLKMUX module in the middle of the HCLK. HCLKMUX can send the HCLK signal from any bank to another, providing enhanced flexibility in the utilization of HCLK.

The function modules that are available for the HCLK resources include:

- DHCEN: Dynamic enable modules for the high-speed clocks. Its function is similar to that of DQCE. It is used to turn on/off the high-speed clock signal dynamically.
- CLKDIV/CLKDIV2: Frequency division modules for the high-speed clocks. There is one CLKDIV in each bank. It is used to generate a frequency-divided clock for IO logic with the same phase as the input clock.
- DCS: Dynamic HCLK selectors.
- DLLDLY: Dynamic delay adjustment modules for the clock signals input via the dedicated clock pins.

2.6.4 DDR Memory Interface Clock Management (DQS)

The DQS module of the GW2A series of FPGA products (Automotive) provides the following features to support the clocking requirements of the DDR memory interface:

- Receives DQS inputs, sorts out waveforms and shifts 1/4 phase
- Provides read/write pointers for the input buffer
- Provides a data valid signal for internal logic
- Provides DDR output clock signals
- Supports DDR3 write voltage control

The DQS module supports multiple modes for different I/O interfaces.

For more information on the GCLKs, HCLKs, and DQSSs, see [UG286, Gowin Clock User Guide](#).

2.7 Long Wires

As a supplement to the CRU, the GW2A series of FPGA products(Automotive) provide another kind of routing resource - the long wire, which can be used for clock, clock enable, set/reset, or other high fan-out signals.

2.8 Global Set/Reset

The GW2A series of FPGA products(Automotive) offer a dedicated global set/reset (GSR) network that connects directly to the device's internal logic and can be used as asynchronous/synchronous set or asynchronous/synchronous reset, with the registers in the CFUs and I/Os being able to be configured independently.

2.9 Programming & Configuration

The GW2A series of FPGA products (Automotive) support SRAM configuration, and the configuration data needs to be re-downloaded upon each power-up. You can also store the configuration data in an external Flash. In this case, the GW2A device loads the configuration data from the external Flash into the SRAM upon power-up.

In addition to JTAG, the GW2A series of FPGA products (Automotive) also support Gowin's own GowinCONFIG configuration mode: SSPI, MSPI, SERIAL, and CPU. For more information, please refer to [UG290, Gowin FPGA Products Programming and Configuration User Guide](#).

2.10 On-chip Oscillator

The GW2A series of FPGA products (Automotive) have an embedded programmable on-chip clock oscillator which provides a clock source for the MSPI configuration mode. See Table 2-9 for the output frequencies. The on-chip oscillator also provides a clock resource for user designs. Up to 64 clock frequencies can be obtained by setting the parameters. The following formula is used to get the output clock frequency:

$$f_{\text{out}}=250\text{MHz}/\text{Param.}$$

Note!

"Param" should be even numbers from 2 to 128.

Table 2-9 Output Frequency Options of the On-chip Oscillator

Mode	Frequency	Mode	Frequency	Mode	Frequency
0	2.5MHz ^[1]	8	7.8MHz	16	15.6MHz
1	5.4MHz	9	8.3MHz	17	17.9MHz
2	5.7MHz	10	8.9MHz	18	21MHz

Mode	Frequency	Mode	Frequency	Mode	Frequency
3	6.0MHz	11	9.6MHz	19	25MHz
4	6.3MHz	12	10.4MHz	20	31.3MHz
5	6.6MHz	13	11.4MHz	21	41.7MHz
6	6.9MHz	14	12.5MHz	22	62.5MHz
7	7.4MHz	15	13.9MHz	23	125MHz ^[2]

Note!

- ^[1] The default frequency is 2.5MHz.
- ^[2] 125MHz is not available for the MSPI configuration mode.

3 DC and Switching Characteristics

Note!

Please ensure that you use Gowin's devices within the recommended operating conditions and ranges. Data beyond the working conditions and ranges are for reference only. Gowin does not guarantee that all devices will operate normally beyond the operating conditions and ranges.

3.1 Operating Conditions

3.1.1 Absolute Max. Ratings

Table 3-1 Absolute Max. Ratings

Name	Description	Min.	Max.
V _{CC}	Core voltage	-0.5V	1.1V
V _{CCPLL}	PLL Voltage	-0.5V	1.1V
V _{CCIO}	I/O Bank voltage	-0.5V	3.75V
V _{CCX}	Auxiliary voltage	-0.5V	3.75V
-	I/O voltage applied ^[1]	-0.5V	3.75V
Storage Temperature	Storage temperature	-65°C	+150°C
Junction Temperature	Junction temperature	-40°C	+125°C

Note!

- ^[1] Overshoot and undershoot of -2V to (V_{IHMAX} + 2)V are allowed for a duration of <20 ns.

3.1.2 Recommended Operating Conditions

Table 3-2 Recommended Operating Conditions

Name	Description	Min.	Max.
V _{CC}	Core voltage	0.95V	1.05V
V _{CCPLLx}	Left PLL Voltage	0.95V	1.05V
V _{CCPLLRx}	Right PLL Voltage	0.95V	1.05V
V _{CCIO}	I/O Bank voltage	1.14V	3.6V

Name	Description	Min.	Max.
V _{CCX}	Auxiliary voltage	2.7V	3.6V
T _{JAUT}	Junction temperature for automotive operations	-40°C	+105°C

Note!

- The allowable ripples on V_{CC}, V_{CCIO}, and V_{CCX} are 3%, 5%, and 5% respectively. 1). For devices of which the PLL is powered directly with V_{CC}, the ripple on V_{CC} can affect the jitter characteristics of the PLL output clock; 2). The ripple on V_{CCIO} can eventually be passed on to the output waveform of the IO Buffer.
- For more information on the power supplies, please refer to [UG110, GW2A-18 Pinout](#).

3.1.3 Power Supply Ramp Rates

Table 3-3 Power Supply Ramp Rates

Name	Description	Min.	Typ.	Max.
V _{CC} Ramp	Power supply ramp rates for V _{CC}	0.1mV/μs	-	10mV/μs
V _{CCIO} /V _{CCX} Ramp	Power supply ramp rates for V _{CCIO} and V _{CCX}	0.01mV/μs	-	100mV/μs

Note!

- A monotonic ramp is required for all power supplies.
- All power supplies need to be in the operating range as defined in Table 3-2 before configuration. Power supplies that are not in the operating range need to be adjusted to a faster ramp rate, or you have to delay configuration.

3.1.4 Hot Socketing Specifications

Table 3-4 Hot Socketing Specifications

Name	Description	Condition	I/O Type	Max.
I _{HS}	Input or I/O leakage current	0 < V _{IN} < V _{IH} (MAX)	I/O	150uA
I _{HS}	Input or I/O leakage current	0 < V _{IN} < V _{IH} (MAX)	TDI, TDO, TMS, TCK	120uA

3.1.5 POR Specifications

Table 3-5 POR Parameters

Name	Description	Device	Name	Value
V _{POR_UP}	Power on reset ramp up trip point	GW2A-18	V _{CC}	0.8V
			V _{CCX}	2.45V
			V _{CCIO}	0.9V
V _{POR_DOWN}	Power on reset ramp down trip point	GW2A-18	V _{CC}	0.7V
			V _{CCX}	2.2V
			V _{CCIO}	0.6V

3.2 ESD performance

Table 3-6 GW2A ESD - HBM

Device	GW2A-18
QN88	HBM>1,000V
PG256	HBM>1,000V

Table 3-7 GW2A ESD - CDM

Device	GW2A-18
QN88	CDM>500V
PG256	CDM>500V

3.3 DC Electrical Characteristics

3.3.1 DC Electrical Characteristics over Recommended Operating Conditions

Table 3-8 DC Electrical Characteristics over Recommended Operating Conditions

Name	Description	Condition	Min.	Typ.	Max.
$I_{IL, I_{IH}}$	Input or I/O leakage current	$V_{CCIO} < V_{IN} < V_{IH}(MAX)$	-	-	210 μ A
		$0V < V_{IN} < V_{CCIO}$	-	-	10 μ A
I_{PU}	I/O Active Pull-up Current	$0 < V_{IN} < 0.7V_{CCIO}$	-30 μ A	-	-150 μ A
I_{PD}	I/O Active Pull-down Current	$V_{IL}(MAX) < V_{IN} < V_{CCIO}$	30 μ A	-	150 μ A
I_{BHLS}	Bus Hold Low Sustaining Current	$V_{IN} = V_{IL}(MAX)$	30 μ A	-	-
I_{BHHS}	Bus Hold High Sustaining Current	$V_{IN} = 0.7V_{CCIO}$	-30 μ A	-	-
I_{BHLO}	Bus Hold Low Overdrive Current	$0 \leq V_{IN} \leq V_{CCIO}$	-	-	150 μ A
I_{BHHO}	Bus Hold High Overdrive Current	$0 \leq V_{IN} \leq V_{CCIO}$	-	-	-150 μ A
V_{BHT}	Bus Hold Trip Points	-	$V_{IL}(MAX)$	-	$V_{IH}(MIN)$

Name	Description	Condition	Min.	Typ.	Max.
C1	I/O Capacitance	-	-	5pF	8pF
V _{HYST}	Hysteresis for Schmitt Trigger inputs	V _{CCIO} =3.3V, Hysteresis=L2H ^{[1],[2]}	-	240mV	-
		V _{CCIO} =2.5V, Hysteresis=L2H	-	140mV	-
		V _{CCIO} =1.8V, Hysteresis=L2H	-	65mV	-
		V _{CCIO} =1.5V, Hysteresis=L2H	-	30mV	-
		V _{CCIO} =3.3V, Hysteresis=H2L ^{[1],[2]}	-	200mV	-
		V _{CCIO} =2.5V, Hysteresis=H2L	-	130mV	-
		V _{CCIO} =1.8V, Hysteresis=H2L	-	60mV	-
		V _{CCIO} =1.5V, Hysteresis=H2L	-	40mV	-
		V _{CCIO} =3.3V, Hysteresis=HIGH ^{[1],[2]}	-	440mV	-
		V _{CCIO} =2.5V, Hysteresis= HIGH	-	270mV	-
		V _{CCIO} =1.8V, Hysteresis= HIGH	-	125mV	-
		V _{CCIO} =1.5V, Hysteresis= HIGH	-	70mV	-

Note!

- [1] Hysteresis="NONE", "L2H", "H2L", "HIGH" indicates the Hysteresis options that can be set when setting I/O Constraints in the FloorPlanner tool of Gowin EDA, for more details, see [SUG935, Gowin Design Physical Constraints User Guide](#).
- [2] Enabling the L2H (low to high) option means raising V_{IH} by V_{HYST}; enabling the H2L (high to low) option means lowering V_{IL} by V_{HYST}; enabling the HIGH option means enabling both L2H and H2L options, i.e. V_{HYST}(HIGH) = V_{HYST}(L2H) + V_{HYST}(H2L). The diagram is shown below.

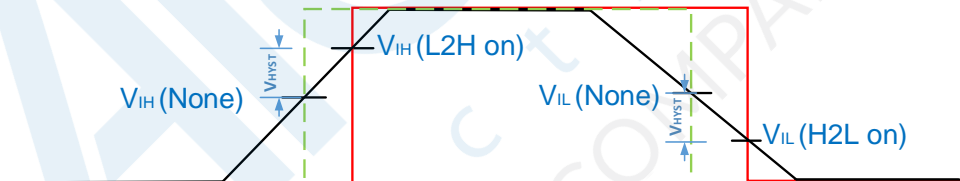

3.3.2 Static Current

Table 3-9 Static Current

Name	Description	Device	Typ.
I _{CC}	V _{CC} current (V _{CC} =1V)	GW2A-18	70mA
I _{CCX}	V _{CCX} current (V _{CCX} =3.3V)	GW2A-18	15mA
I _{CCIO}	V _{CCIO} current (V _{CCIO} =3.3V)	GW2A-18	<2mA

Note!

Test condition(s): room temperature.

3.3.3 Recommended I/O Operating Conditions

Table 3-10 Recommended I/O Operating Conditions

Name	V _{CCIO} (V) for Output			V _{REF} (V) for Input		
	Min.	Typ.	Max.	Min.	Typ.	Max.

Name	V _{CCIO} (V) for Output			V _{REF} (V) for Input		
	Min.	Typ.	Max.	Min.	Typ.	Max.
LVTTTL33	3.135	3.3	3.6	-	-	-
LVC MOS33	3.135	3.3	3.6	-	-	-
LVC MOS25	2.375	2.5	2.625	-	-	-
LVC MOS18	1.71	1.8	1.89	-	-	-
LVC MOS15	1.425	1.5	1.575	-	-	-
LVC MOS12	1.14	1.2	1.26	-	-	-
SSTL15	1.425	1.5	1.575	0.68	0.75	0.9
SSTL18_I	1.71	1.8	1.89	0.833	0.9	0.969
SSTL18_II	1.71	1.8	1.89	0.833	0.9	0.969
SSTL25_I	2.375	2.5	2.645	1.15	1.25	1.35
SSTL25_II	2.375	2.5	2.645	1.15	1.25	1.35
SSTL33_I	3.135	3.3	3.6	1.3	1.5	1.7
SSTL33_II	3.135	3.3	3.6	1.3	1.5	1.7
HSTL18_I	1.71	1.8	1.89	0.816	0.9	1.08
HSTL18_II	1.71	1.8	1.89	0.816	0.9	1.08
HSTL15	1.425	1.5	1.575	0.68	0.75	0.9
PCI33	3.135	3.3	3.6	-	-	-
LVPECL33E	3.135	3.3	3.6	-	-	-
MLVDS25E	2.375	2.5	2.625	-	-	-
BLVDS25E	2.375	2.5	2.625	-	-	-
RSDS25E	2.375	2.5	2.625	-	-	-
LVDS25E ^[1]	2.375	2.5	2.625	-	-	-
SSTL15D	1.425	1.5	1.575	-	-	-
SSTL18D_I	1.71	1.8	1.89	-	-	-
SSTL18D_II	1.71	1.8	1.89	-	-	-
SSTL25D_I	2.375	2.5	2.625	-	-	-
SSTL25D_II	2.375	2.5	2.625	-	-	-
SSTL33D_I	3.135	3.3	3.6	-	-	-
SSTL33D_II	3.135	3.3	3.6	-	-	-
HSTL15D	1.425	1.575	1.89	-	-	-
HSTL18D_I	1.71	1.8	1.89	-	-	-
HSTL18D_II	1.71	1.8	1.89	-	-	-

Note!

^[1] V_{CCIO} of banks using True LVDS is recommended to be set to 2.5V.

3.3.4 Single-ended I/O DC Characteristics

Table 3-11 Single-ended I/O DC Characteristics

Name	V _{IL}		V _{IH}		V _{OL} (Max)	V _{OH} (Min)	I _{OL} ^[1] (mA)	I _{OH} ^[1] (mA)
	Min	Max	Min	Max				
LVCMOS33 LVTTTL33	-0.3V	0.8V	2.0V	3.6V	0.4V	V _{CCIO} -0.4V	4	-4
							8	-8
							12	-12
							16	-16
					24	-24		
					0.2V	V _{CCIO} -0.2V	0.1	-0.1
LVCMOS25	-0.3V	0.7V	1.7V	3.6V	0.4V	V _{CCIO} -0.4V	4	-4
							8	-8
							12	-12
							16	-16
LVCMOS18	-0.3V	0.35 x V _{CCIO}	0.65 x V _{CCIO}	3.6V	0.4V	V _{CCIO} -0.4V	4	-4
							8	-8
LVCMOS15	-0.3V	0.35 x V _{CCIO}	0.65 x V _{CCIO}	3.6V	0.4V	V _{CCIO} -0.4V	4	-4
LVCMOS12	-0.3V	0.35 x V _{CCIO}	0.65 x V _{CCIO}	3.6V	0.4V	V _{CCIO} -0.4V	2	-2
							4	-4
PCI33	-0.3V	0.3 x V _{CCIO}	0.5 x V _{CCIO}	3.6V	0.1 x V _{CCIO}	0.9 x V _{CCIO}	1.5	-0.5
SSTL33_I	-0.3V	V _{REF} -0.2V	V _{REF} +0.2V	3.6V	0.7	V _{CCIO} -1.1V	8	-8
SSTL25_I	-0.3V	V _{REF} -0.18V	V _{REF} +0.18V	3.6V	0.54V	V _{CCIO} -0.62V	8	-8
SSTL25_II	-0.3V	V _{REF} -0.18V	V _{REF} +0.18V	3.6V	NA	NA	NA	NA
SSTL18_II	-0.3V	V _{REF} -0.125V	V _{REF} +0.125V	3.6V	NA	NA	NA	NA
SSTL18_I	-0.3V	V _{REF} -0.125V	V _{REF} +0.125V	3.6V	0.40V	V _{CCIO} -0.40V	8	-8
SSTL15	-0.3V	V _{REF} -0.1V	V _{REF} + 0.1V	3.6V	0.40V	V _{CCIO} -0.40V	8	-8
HSTL18_I	-0.3V	V _{REF} -0.1V	V _{REF} + 0.1V	3.6V	0.40V	V _{CCIO} -0.40V	8	-8
HSTL18_II	-0.3V	V _{REF} -0.1V	V _{REF} + 0.1V	3.6V	NA	NA	NA	NA
HSTL15_I	-0.3V	V _{REF} -0.1V	V _{REF} + 0.1V	3.6V	0.40V	V _{CCIO} -0.40V	8	-8
HSTL15_II	-0.3V	V _{REF} -0.1V	V _{REF} + 0.1V	3.6V	NA	NA	NA	NA

Note!

The total DC current limit(sourced and sunk current) of all IOs in the same bank: the total

DC current of all IOs in the same bank shall not be greater than $n \cdot 8\text{mA}$, where n represents the number of IOs bonded out from a bank.

3.3.5 Differential I/O DC Characteristics

Table 3-12 Differential I/O DC Characteristics

LVDS

Name	Description	Test conditions	Min.	Typ.	Max.	Unit
V_{INA}, V_{INB}	Input Voltage		0	-	2.4	V
V_{CM}	Input Common Mode Voltage	Half the Sum of the Two Inputs	0.05	-	2.35	V
V_{THD}	Differential Input Threshold	Difference Between the Two Inputs	± 100	-	± 600	mV
I_{IN}	Input Current	Power On or Power Off	-	-	± 10	μA
V_{OH}	Output High Voltage for V_{OP} or V_{OM}	$R_T = 100\Omega$	-	-	1.60	V
V_{OL}	Output Low Voltage for V_{OP} or V_{OM}	$R_T = 100\Omega$	0.9	-	-	V
V_{OD}	Output Voltage Differential	$(V_{OP} - V_{OM}), R_T = 100\Omega$	250	350	450	mV
ΔV_{OD}	Change in V_{OD} Between High and Low		-	-	50	mV
V_{OS}	Output Voltage Offset	$(V_{OP} + V_{OM})/2, R_T = 100\Omega$	1.125	1.20	1.375	V
ΔV_{OS}	Change in V_{OS} Between High and Low		-	-	50	mV
I_S	Short-circuit current	$V_{OD} = 0\text{V}$ outputs short-circuited	-	-	15	mA

3.4 Switching Characteristics

3.4.1 CFU Switching Characteristics

Table 3-13 CFU Timing Parameters

Name	Description	Speed Grade		Unit
		Min	Max	
t_{LUT4_CFU}	LUT4 delay	-	0.337	ns
t_{LUT5_CFU}	LUT5 delay	-	0.694	ns
t_{LUT6_CFU}	LUT6 delay	-	1.005	ns
t_{LUT7_CFU}	LUT7 delay	-	1.316	ns
t_{LUT8_CFU}	LUT8 delay	-	1.627	ns
t_{SR_CFU}	Set/Reset to Register output	-	0.93	ns

Name	Description	Speed Grade		Unit
		Min	Max	
t _{CO_CFU}	Clock to Register output	-	0.38	ns

3.4.2 BSRAM Switching Characteristics

Table 3-14 BSRAM Timing Parameters

Name	Description	Speed Grade		Unit
		Min	Max	
t _{COAD_BSRAM}	Clock to output from read address/data	-	2.55	ns
t _{COOR_BSRAM}	Clock to output from output register	-	0.28	ns

3.4.3 DSP Switching Characteristics

Table 3-15 DSP Timing Parameters

Name	Description	Speed Grade		Unit
		Min	Max	
t _{COIR_DSP}	Clock to output from input register	-	2.40	ns
t _{COPR_DSP}	Clock to output from pipeline register	-	1.20	ns
t _{COOR_DSP}	Clock to output from output register	-	0.42	ns

3.4.4 Gearbox Switching Characteristics

Table 3-16 Gearbox Timing Parameters

Device	Name	Description	Max.	Unit
GW2A-18	F _{MAX_IDDR}	1:2 Gearbox maximum serial input rate	400	Mbps
	F _{MAX_IDES4}	1:4 Gearbox maximum serial input rate	800	Mbps
	F _{MAX_IDES7}	1:7 Gearbox maximum serial input rate	1000	Mbps
	F _{MAX_IDESx}	1:8/1:10 Gearbox maximum serial input rate	1200	Mbps
	F _{MAX_ODDR}	2:1 Gearbox maximum serial output rate	400	Mbps
	F _{MAX_OSER4}	4:1 Gearbox maximum serial output rate	800	Mbps
	F _{MAX_OSER7}	7:1 Gearbox maximum serial output rate	1000	Mbps
	F _{MAX_OSERx}	8:1/10:1 Gearbox maximum serial output rate	1200	Mbps

3.4.5 Clock and I/O Switching Characteristics

Table 3-17 External Switching Characteristics

Device	Name	Description	A6		Unit
			Min	Max	
GW2A-18	Pin-LUT-Pin Delay ⁽¹⁾	Pin(IOxA) to Pin(IOxB) delay	-	TBD	ns
	T _{HCLKdly}	HCLK tree delay	-	TBD	ns
	T _{GCLKdly}	GCLK tree delay	-	TBD	ns

3.4.6 On-chip Oscillator Switching Characteristics

Table 3-18 On-chip Oscillator Switching Characteristics

Name	Description	Min.	Typ.	Max.
f _{MAX}	Output Frequency (-40 to +105°C)	100MHz	125MHz	150MHz
t _{DT}	Output Clock Duty Cycle	43%	50%	57%
t _{OPJIT}	Output Clock Period Jitter	0.01UIPP	0.012UIPP	0.02UIPP

3.4.7 PLL Switching Characteristics

Table 3-19 PLL Switching Characteristics

Device	Speed Grade	Name	Min.	Max.
GW2A-18	A6	CLKIN	3MHz	500MHz
		PFD	3MHz	500MHz
		VCO	500MHz	1250MHz
		CLKOUT	3.90625MHz	625MHz

3.5 Configuration Interface Timing Specification

The GW2A series of FPGA products (Automotive) support multiple GowinCONFIG modes, including MSPI, SSPI, SERIAL, CPU. For more information, please refer to [UG290, Gowin FPGA Products Programming and Configuration User Guide](#).

4 Ordering Information

4.1 Part Naming

Figure 4-1 Part Naming - Production

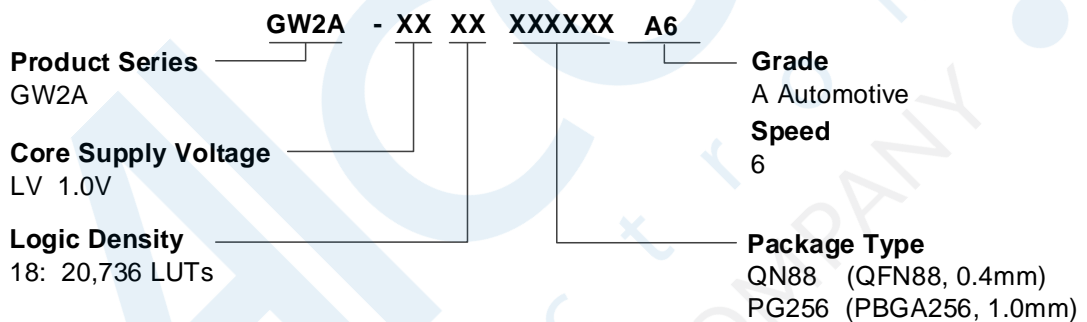

Note!

- For more information about the packages, please refer to [1.2 Product Resources](#).
- The LittleBee family devices and Arora family devices of the same speed grade have different speeds.

4.2 Package Markings

Gowin's devices have markings on the their surfaces, as shown in Figure 4-2.

Figure 4-2 Package Marking Examples

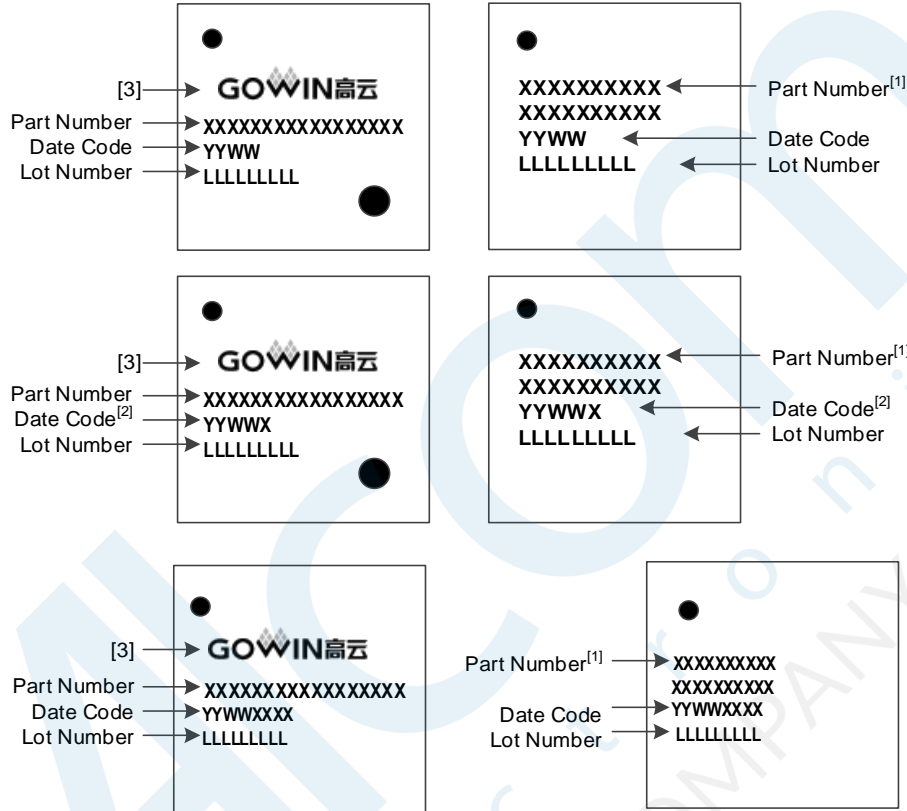

Note!

- ^[1] The first two lines in the right figure(s) above are both the “Part Number”.
- ^[2] The Date Code followed by an “X” is for X version devices.
- ^[3] Whether the package marking bears the Gowin Logo or not depends on the package type, package size, and Part Number length. The above figure are only examples of the package markings.

5 About This Manual

5.1 Purpose

This datasheet provides a comprehensive overview of the GW2A series of FPGA products (Automotive), including their features, resources, architecture, AC/DC characteristics, and ordering details. It aims to enhance accessibility and facilitate the effective utilization of Gowin's devices.

5.2 Related Documents

The latest documents are available at www.gowinsemi.com.

- [UG290, Gowin FPGA Products Programming and Configuration User Guide](#)
- [UG111, GW2A series of FPGA Products Package & Pinout User Guide](#)
- [UG110, GW2A-18 Pinout](#)

5.3 Terminology and Abbreviations

The terminology and abbreviations used in this manual are shown in Table 5-1.

Table 5-1 Terminology and Abbreviations

Terminology and Abbreviations	Full Name
ALU	Arithmetic Logic Unit
BSRAM	Block Static Random Access Memory
CFU	Configurable Function Unit
CLS	Configurable Logic Section
CRU	Configurable Routing Unit
DCS	Dynamic Clock Selector
DP	True Dual Port 16K BSRAM
DQCE	Dynamic Quadrant Clock Enable

Terminology and Abbreviations	Full Name
DSP	Digital Signal Processing
FPGA	Field Programmable Gate Array
GPIO	Gowin Programmable IO
IOB	Input/Output Block
LUT4	4-input Look-up Table
LUT5	5-input Look-up Table
LUT6	6-input Look-up Table
LUT7	7-input Look-up Table
LUT8	8-input Look-up Table
PG256	PBGA256
PLL	Phase-locked Loop
QN88	QFN88
REG	Register
SDP	Semi Dual Port 16K BSRAM
SP	Single Port 16K BSRAM
SSRAM	Shadow Static Random Access Memory
TDM	Time Division Multiplexing

5.4 Support and Feedback

Gowin Semiconductor provides customers with comprehensive technical support. If you have any questions, comments, or suggestions, please feel free to contact us directly using the information provided below.

Website: www.gowinsemi.com

E-mail: support@gowinsemi.com

